



8QT LOCKING LID SLOW COOKER **USER GUIDE**

IMPORTANT SAFEGUARDS

When using an electrical appliance, basic safety precautions should always be followed, including the following:

1. **IMPORTANT:** Read all instructions carefully before first use.
2. This product is not meant for deep frying.
3. Do not touch hot surfaces. The metal housing will become hot during use. Use handles on side or on lid.
4. **CAUTION:** Lid and handles may become hot during prolonged use. Use caution when removing lid or lifting by handles. To reduce the risk of electric shock, cook only in removable inner bowl.
5. Use tongs or other heat safe utensils to remove food. Do not pour or lift appliance.
6. Close supervision is necessary when any appliance is used by or near children.
7. To protect against electrical shock, do not immerse cord, plug, or cooker body in water or other liquid.
8. Do not add liquid within an inch of the top of aluminum inner pot, or the water may flow out during cooking.
9. Do not allow food to boil or cook dry.
10. Unplug from outlet when not in use and before cleaning. Allow to cool before putting on or taking off parts, and before cleaning the appliance. Do not use abrasive cleaning solutions, steel wool or nylon scrubbing sponges.
11. Do not operate any appliance with a damaged cord or plug or after the appliance malfunctions or has been damaged in any manner. Return appliance to the nearest authorized service facility for examination, repair, or adjustment.
12. The use of accessory attachments not recommended by the appliance manufacturer may cause injuries.
13. Intended for counter top use only as directed.
14. Do not use the appliance for other than intended use.
15. Do not use outdoors.
16. Extreme caution must be used when moving an appliance containing hot liquids.
17. Do not let cord touch hot surfaces or hang over the edge of table or counter.
18. **WARNING:** Spilled food can cause serious burns. Keep appliance and cord away from children. Never drape cord over edge of counter, never use outlet below counter, and never use with an extension cord.
19. Prior to first use, please make sure that the electrical rating of the appliance is in conformity with the current electric rating.
20. Plug cord into wall outlet. To disconnect, switch appliance off, then remove plug from wall outlet.
21. The bowl is used on stove top or in oven only as directed. When cooking on a burner make sure it is of a similar base diameter to the bowl.
22. To reduce the risk of electric shock, cook only in removable bowl. **DO NOT** pour food directly in the unit base without bowl.
23. When using bowl to cook on gas, adjust flame so it does not flare up on the sides of the bowl. Ensure heat does not exceed 390°F.
24. **SAVE THESE INSTRUCTIONS** Do not throw away. Read before operating your new Slow Cooker. Keep for future reference.
25. In order to ensure safe operation and optimum performance, please read the entire Instruction/Care & Use Booklet.
26. Do not place on or near a hot gas or electric burner, or in a heated oven.

SAVE THESE INSTRUCTIONS FOR HOUSEHOLD USE ONLY

SPECIAL CORD SET INSTRUCTIONS:

A short power-supply cord is provided to reduce the risks resulting from becoming entangled in or tripping over a longer cord.

Warning: This appliance has a polarized plug (one blade is wider than the other). To reduce the risk of electric shock, this plug is intended to fit into a polarized outlet only one way. If the plug does not fit fully into the outlet, reverse the plug. If it still does not fit, contact a qualified electrician. Do not attempt to modify the plug in any way.

HEALTHY COOKING STARTS WITH GREENPAN

Since inventing healthy ceramic nonstick in 2007, we've dedicated ourselves to unique advances that make cooking better for everyone. From healthy ceramic nonstick cookware to revolutionary home appliances, our groundbreaking designs deliver remarkable performance so you can focus on the flavor. Enjoy!

CONTENTS

- 04 Description of Parts**
- 04 Before First Use**
- 04 General Usage**
- 05 Operation**
- 08 Cleaning/Maintenance**
- 09 Troubleshooting**
- 10 Warranty**

PARTS

- A. Glass Lid
- B. Locking Lid
- C. Locking Lid Latches
- D. 8QT Slow Cooker Bowl
- E. Inner Housing
- F. Body Side Handles
- G. Power Cord
- H. Control Panel

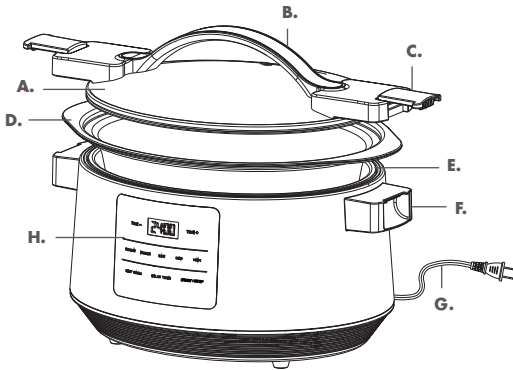

BEFORE FIRST USE

1. Read all instructions and important safeguards.
 2. Remove all packaging materials and check that all items have been received in good condition.
 3. Tear up all plastic bags and dispose of properly as they can pose a suffocation or choking risk to children.
 4. Remove the lid and the removable 8QT Slow Cooker Bowl and wash with warm soapy water and dry thoroughly before returning to the base.
 5. Wipe body clean with a damp cloth.
- NOTE: Do not use harsh abrasive cleaners, scouring pads or products that are not considered safe to use on nonstick coatings. If washing dishwasher safe parts in the dishwasher, a slight discoloration to the 8QT Slow Cooker Bowl and accessories may occur. This is cosmetic only and will not affect performance.
6. Place 8QT Slow Cooker Bowl inside of the inner housing, and place lid on top of 8QT Slow Cooker Bowl.
 7. Plug power cord into outlet.
 8. Your Slow Cooker is now ready for use.

GENERAL USAGE

KNOW YOUR CONTROL PANEL

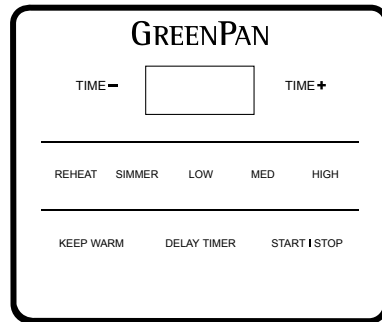

REHEAT- Use REHEAT mode to heat up cooked food quickly before serving.

SIMMER- Use SIMMER mode for soups, stews and homemade stocks. The longer the cooking time, the more flavorful your stock soups and stews will be. Also perfect for entertaining and serving.

LOW- Use LOW mode for recipes that have extended cooking times and more complex proteins.

MED (MEDIUM)- Use MED mode for when a little more heat is needed or if you are using large cuts of protein.

HIGH- Use HIGH mode for higher heat over a shorter period of time. Good for poultry and less tough proteins. This can also be used for "baking" in your slow cooker.

KEEP WARM- KEEP WARM mode is intended only for keeping already cooked food warm, not for cooking. This is selectable option or will automatically start after cooking.

DELAY TIMER- Use DELAY TIMER to plan your meals up to 24 hours in advance.

START | STOP- Use the START | STOP button to confirm or turn off the mode you selected.

TIME - Use this button to decrease the timer setting on modes.

TIME + Use this button to increase the timer setting on modes.

OPERATION

Power Operation

1. Ensure your Slow Cooker is plugged directly into a wall outlet. Do not use an extension cord.
2. Be sure that the 8QT Slow Cooker Bowl is correctly placed within the appliance and the appliance is on a level heat-resistant surface.
3. Once plugged in the START | STOP button will flash.
4. Press any mode you want to cook with. The indicator of the mode selection will light on and the START | STOP and LED display will flash until START | STOP is pressed.
5. Adjust Default Cooking time if needed. Press START | STOP button to begin cooking.
6. Lock the lid into place using the locking lid latches and body side handles.
7. After Time has completed the 8QT Locking Lid Slow Cooker will go into Keep Warm on (excluding Keep Warm mode).

COOKING MODES

Slow Cook Modes

Slow cooking works best with foods that require long, low-heat cooking. Examples: stews, soups, beans, and fattier meats such as roasts, pork shoulder, and ribs.

REHEAT

1. Press REHEAT Mode on the Slow Cooker Control Panel. REHEAT Mode indicator light will be on to show this mode is selected.
2. Use default time on screen or modify time by pressing Time - or Time + button and press START | STOP button to begin mode.
3. If you want to modify time while cooking press Time - or Time + button. After 5 seconds the time you selected will lock in or press START | STOP to start new time immediately.
4. After Time has elapsed Food will automatically go into keep warm mode. The timer will count up for 8 hours and shut off after completed.

SIMMER

1. Press SIMMER Mode on the Slow Cooker Control Panel. SIMMER Mode indicator light will be on to show this mode is selected.

2. Use default time on screen or modify time by pressing Time - or Time + button and press START | STOP button to begin mode.
3. If you want to modify time while cooking press Time - or Time + button. After 5 seconds the time you selected will lock in or press START | STOP to start new time immediately.
4. After time has elapsed, Slow Cooker will automatically go into Keep Warm mode. The timer will count up for 8 hours and shut off after completed.

LOW

1. Press LOW Mode on the Slow Cooker Control Panel. LOW Mode indicator light will be on to show this mode is selected.
2. Use default time on screen or modify time by pressing Time - or Time + button and press START | STOP button to begin mode.
3. If you want to modify time while cooking press Time - or Time + button. After 5 seconds the time you selected will lock in or press START | STOP to start new time immediately.
4. After time has elapsed, Slow Cooker will automatically go into Keep Warm mode. The timer will count up for 8 hours and shut off after completed.

MED (MEDIUM)

1. Press MED Mode on the Slow Cooker Control Panel. MED Mode indicator light will be on to show this mode is selected.
2. Use default time on screen or modify time by pressing Time - or Time + button and press START | STOP button to begin mode.
3. If you want to modify time while cooking press Time - or Time + button. After 5 seconds the time you selected will lock in or press START | STOP to start new time immediately.
4. After time has elapsed, Slow Cooker will automatically go into Keep Warm mode. The timer will count up for 8 hours and shut off after completed.

HIGH

1. Press HIGH Mode on the Slow Cooker Control Panel. HIGH Mode indicator light will be on to show this mode is selected.
2. Use default time on screen or modify time by pressing Time - or Time + button and press START | STOP button to begin mode.
3. If you want to modify time while cooking press Time - or Time + button. After 5 seconds the time you selected will lock in or press START | STOP to start new time immediately.

4. After time has elapsed, Slow Cooker will automatically go into Keep Warm mode. The timer will count up for 8 hours and shut off after completed.

KEEP WARM

NOTE: This mode is intended only for keeping already cooked food warm, not for cooking.

1. Press KEEP WARM Mode on the Slow Cooker Control Panel. KEEP WARM Mode indicator light will be on to show this mode is selected.
2. Use default time on screen or modify time by pressing Time - or Time + button and press START | STOP button to begin mode.
3. If you want to modify time while cooking press Time - or Time + button. After 5 seconds the time you selected will lock in or press START | STOP to start new time immediately.

TIME - & TIME +

1. Press TIME - or TIME + to change default cooking time.
2. This can be done before a mode has started or during the cooking process.
3. To change time before a mode starts Press TIME - or TIME + while indicator light of the START | STOP is flashing, then press START | STOP to start new time immediately.
4. The timer setting will increase or decrease in increments of 30 mins for LOW, MED, HIGH, KEEP WARM & DELAY TIMER. REHEAT mode will increase or decrease in increments of 10 mins. SIMMER mode will increase or decrease in increments of 10 mins for the first hour. After setting time for more than 1 hour increments will increase to 30 mins.
5. The Timer can be used during the cooking process if you need to adjust the amount of time simply press TIME - or TIME + to modify. Time on the LED will flash. After new time has been selected press START | STOP to confirm or wait 5 seconds.

DELAY TIMER

1. Postpone cooking up to 24 hours. Press Cooking Mode you wish to use before pressing DELAY TIMER.
2. Select from LOW, MED, HIGH, REHEAT or SIMMER.

3. Before selecting DELAY TIMER if you do not want to use a default time. Modify TIME- or TIME + to increase or decrease preset cooking time.
4. Press DELAY TIMER and set time for how long you want to wait before previously selected program will begin.
5. DELAY TIMER will flash until time is confirmed with START | STOP button.
6. Press TIME - or TIME + to decrease or increase delay timer start time.
7. Press START | STOP to confirm.
8. If you want to modify the mode cooking time while waiting for delay timer to expire press the mode you want to modify. The mode will flash allowing you to adjust the TIME- and TIME+. Press START | STOP to confirm new time for mode or wait 5 seconds.
9. Once the delay timer has expired, Delay timer indicator light will turn OFF, and the unit will start cooking.

Please Note – While using delay timer we suggest using ingredients that will not spoil while being left out. Suggested maximum delay-start time for uncooked meat or chicken is two hours.

RECIPE TIPS

- Be sure to spread oil in the Slow Cooker before cooking, using a heat-resistant spatula or other utensil. Do not use cooking sprays. Cooking sprays will carbonize quickly and damage the ceramic nonstick coating.
- Always use tongs or other utensil to remove food. Do not lift the Slow Cooker to pour.
- The Slow Cooker must be placed on a level surface during use – uneven cooking or spilling may result otherwise.
- The Locking Lid Slow Cooker comes with a coated 8QT Bowl with a special PFAS-FREE coating designed for kitchen appliances. The 8QT Slow Cooker Bowl is stovetop and oven safe to 400°F.
- When Browning/Sautéing, always use a little oil or butter suited for frying for best results. Avoid low smoke point oil or aerosol sprays as they cannot withstand high heat.

STOVETOP AND OVEN COOKING

Please remove 8QT Slow Cooker bowl from the inner housing to cook on the stovetop. The housing and lid are not stovetop safe. REMOVE LID before placing on stovetop or in oven.

The Slow Cooker Bowl is oven and stovetop safe to 400°F. When cooking on a gas stovetop adjust flame so it does not flare up on the sides of the 8QT Slow Cooker Bowl. Do not exceed 400°F. For standard electric stovetops, the typical Medium setting is 400°F. Do not use higher settings.

For oven use, ensure that temperature does not exceed 400°F. When taking the bowl out of the oven, be sure that you use safety gloves or oven mitts. This bowl will be hot, so proceed with caution.

MODE SUMMARY CHART

Setting	Guidelines	Recipes	Default Time	Time Range	Auto Keep Warm
HIGH	Use HIGH mode for higher heat over a shorter period. Good for poultry and less tough proteins. This can also be used for “baking” in your slow cooker.	Poultry, Casseroles, Puddings, Cheesecakes, rolls	4 Hours	0:30 to 12 Hours	Y
MED (Medium)	Use MED mode for when a little more heat is needed or if you are using large cuts of protein.	Large cuts of protein, Desner stocks.	6 Hours	0:30 to 12 Hours	Y
LOW	Use LOW mode for recipes that have extended cooking times and more complex proteins.	Braises, Roasts, Stew, ribs, Casseroles, Shanks, Chops, less tender cuts of meat, soups.	8 Hours	0:30 to 24 Hours	Y
SIMMER	Use SIMMER mode for soups, stews and homemade stocks. The longer the cooking time, the more flavor your stock soups and stews will be. Also perfect for entertaining and serving.	Soups, Stews, Stocks Serving	2 Hours	0:10 to 8 Hours	Y
REHEAT	REHEAT mode will quickly reheat already cooked food. Not designed for extended cooking time due to the high heat.	N/A	1 Hour	0:10 to 3 Hours	Y
KEEP WARM	KEEP WARM mode is intended only for keeping already cooked food warm, not for cooking. This is selectable option under the slow cook modes or will automatically start after cooking. The timer will count up to 8 hours, after a mode has been completed to indicate elapsed time. If selected as a mode, you will be able to set time for up to 8 hours. If Keep Warm is selected the timer will count down.	N/A	4 hours	0:30 to 8 Hours	N
DELAY TIMER	Use DELAY TIMER mode to plan meals up to 24 hours in advance.	N/A	1 Hour	0:30 to 24 Hours	N

HOW TO TRANSPORT SLOW COOKER

1. Secure the Glass Lid onto 8QT Slow Cooker Bowl, make sure the Lid latches on side of the lid line up with the side handle.
2. Press the lid latches down to lock into the body side handles. A snapping sound should be heard once it is in the right position.
3. **IMPORTANT:** When the Lid is locked, use both side handles to transport the Slow Cooker. NEVER use lid handle to move the Slow Cooker.
4. When ready to serve, pull the lid latches up from the side handles, then remove the Locking Lid.

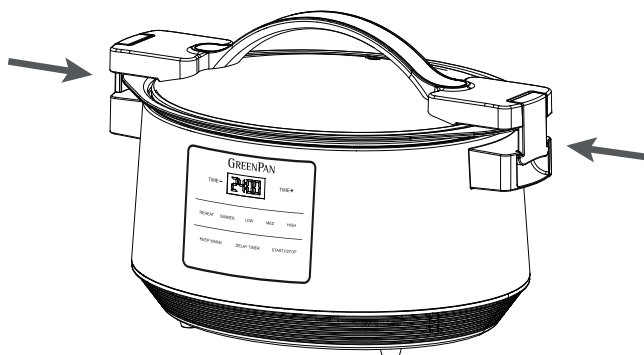

CLEANING AND MAINTENANCE

1. Before cleaning, always unplug your Slow Cooker and allow it to cool. The inner pot and lid are both safe for dishwasher use.
2. If you prefer, you can wash the inner pot and lid with a gentle detergent after removing them from the base.
3. Rinse with water and then gently pat dry with a dish towel or cloth.
4. Wipe the outside of the Slow Cooker with a damp sponge or cloth. Refrain from using scouring pads, brushes, powders or chemical detergents on the Slow Cooker.

Note: Any other servicing should be performed by an authorized service representative.

Summary Chart:

Part	Diswasher Safe	Wipe with Damp Cloth
Locking Lid	✓	✓
Removable 8QT Slow Cooker Bowl	✓	✓
Slow Cooker Housing	✗	✓

STORAGE

Ensure the Slow Cooker is cool and dry before storing. The power cord wraps around the built in cord wrap for easy storage.

BEFORE RETURNING YOUR GREENPAN PRODUCT

If you are experiencing problems with your GreenPan Slow Cooker, we suggest that you call GreenPan customer service at 877-926-6526 before returning the product. A representative can confirm whether the product is under warranty and advise on next steps.

IMPORTANT: If the defective product is to be serviced by someone other than GreenPan's authorized service, please tell the servicer to call our consumer service at 877-926-6526 to ensure that the problem is properly diagnosed, the product is serviced with the correct parts, and the product is still under warranty.

TROUBLESHOOTING

Problem	Cause	Solution
Slow Cooker does not turn on	Power Plug	Check whether the power plug is connected to a functional, electrical outlet
Outside of Slow Cooker is hot during use	This is normal, especially after extended use	Do not touch the outside of the Slow Cooker, burns may result. Instead use handles only when Slow Cooker is operating.
Slow Cooker turns on, but does not get hot during any cooking mode	Internal Error	Contact Customer Service
Appliance slow to heat up	Slow Cooker Bowl not seated correctly or debris in way	Ensure that there is no debris or oil affecting the connection to heating element to the Slow Cooker Bowl. If this does not work, contact customer service.
Food is undercooked	Check cooking time and temperature	Increase cooking time, or check C&U for alternate mode.
Food is overcooked	Check cooking time and temperature	Decrease cooking time, or check C&U for alternate mode.
Small scratch mark or dent appear on cooking surface	Normal Use	Chipping up to 1 to 2 mm is a perfectly normal occurrence because ceramic coatings are very hard – i.e. in the same way as Porcelain Ceramics are hard but not very flexible.
Large scratch mark or dent mark appear on cooking surface	N/A	Contact Customer Service

LIMITED WARRANTY

GreenPan Electrics are covered by a limited warranty against defects in materials and workmanship, beginning on the date you receive the product and lasting for two years. If your GreenPan Electrics product has a defect covered by the limited warranty during the warranty period, The Cookware Company (USA), LLC will either repair or replace the product. Further information on the warranty claim process, exclusions from warranty coverage, and other terms can be found in the complete limited warranty for this product, available online at greenpan.us/warranty.

TERMS OF SALE; ARBITRATION

The terms on which The Cookware Company (USA), LLC sells GreenPan Electrics are available online at greenpan.us/pages/terms-of-sale (the "Terms"). The Terms contain very important information regarding your rights and obligations, as well as conditions, limitations, and exclusions that may apply to you. Please read them carefully.

In particular, the Terms provide that, by your purchase of this product, you and The Cookware Company (USA), LLC are agreeing to give up any rights to litigate in a court or before a jury, or to participate in a class action or representative action with respect to a claim. Other rights that you would have if you went to court may also be unavailable or limited in arbitration. Any claim, dispute, or controversy between you and The Cookware Company (USA), LLC arising from or relating in any way to your purchase of products or services will be resolved exclusively and finally by binding arbitration.

The arbitration will be administered by the American Arbitration Association ("AAA") in accordance with the Consumer Arbitration Rules (the "AAA Rules") then in effect, except as modified hereby. (The AAA Rules are available at adr.org or by calling the AAA at 1-800-778-7879.) The Federal Arbitration Act will govern the interpretation and enforcement of this arbitration and waiver provision. The Cookware Company (USA), LLC will be responsible for the AAA filing fee of any such

proceeding. Other than your right to pursue a claim in small claims court, as described in the Terms, the arbitrator will have exclusive authority to resolve any dispute relating to arbitrability and/or enforceability of this arbitration provision, including any unconscionability challenge or any other challenge that the arbitration provision or these Terms are void, voidable or otherwise invalid. The arbitrator will be empowered to grant whatever relief would be available in court under law or in equity. Any award of the arbitrator(s) will be final and binding on each of the parties and may be entered as a judgment in any court of competent jurisdiction. Attorney fee shifting in this case is governed by the Terms. You agree to an arbitration on an individual basis. In any dispute, NEITHER YOU NOR THE COOKWARE COMPANY (USA), LLC WILL BE ENTITLED TO JOIN OR CONSOLIDATE CLAIMS BY OR AGAINST OTHER CUSTOMERS IN COURT OR IN ARBITRATION OR OTHERWISE PARTICIPATE IN ANY CLAIM AS A CLASS REPRESENTATIVE, CLASS MEMBER OR IN A PRIVATE ATTORNEY GENERAL CAPACITY. The arbitral tribunal may not consolidate more than one person's claims, and may not otherwise preside over any form of a representative or class proceeding. The arbitral tribunal has no power to consider the enforceability of this class arbitration waiver and any challenge to the class arbitration waiver may only be raised in a court of competent jurisdiction. If any provision of the arbitration agreement described herein and in the Terms is found unenforceable, the unenforceable provision will be severed and the remaining arbitration terms will be enforced.



1400029647