



The Signature of Quality®

INSTALLATION OPERATION INSTRUCTIONS

Self-Contained
Including Hybrid

RSS3-2B & -3B
RSS4-2B & -3B



KEEP THIS MANUAL FOR FUTURE REFERENCE
Engineering and technical data are subject to change without notice.

FEDERAL INDUSTRIES
Toll Free 1(800)356-4206

215 Federal Avenue
WI Phone (608)424-3331

Belleville, WI 53508
Fax: (608)424-3234

Contents

COVER.....	1
CONTENTS.....	2
INTRODUCTION.....	3
WARNING LABELS & SAFETY INSTRUCTIONS.....	4
REFRIGERATION WARNING INSTALL-REPAIR-DECOMMISSIONING.....	5-10
PRE-INSTALLATION PROCEDURES.....	11
INSPECTION FOR SHIPPING DAMAGE.....	11
INSTALLATION INSTRUCTIONS.....	11
LOCATING THE DISPLAY CASE.....	11
LEVELING THE CASE.....	12
GRILL REMOVAL.....	12
CONDENSATE EVAPORATOR.....	12
ELECTRICAL INFORMATION & GROUNDING	13
OPERATING INSTRUCTIONS.....	14
CONTROLS.....	14
TEMPERATURE CONTROL.....	14-17
INITIAL STARTUP.....	18
PLACING PRODUCT IN CASE.....	18
PERIODIC MAINTENANCE.....	19
SERVICE INFORMATION.....	20
PRE-SERVICE CHECKLIST.....	21
SPECIAL SERVICE SITUATIONS.....	22
SALE & DISPOSAL.....	23
OWNER RESPONSIBILITY.....	23
REFRIGERATION & ELECTRICAL DATA- RSS3 & 4 SC-2B & -3B.....	24
REPLACEMENT PARTS- RSS3 & RSS4 -2B & -3B.....	25
WIRING DIAGRAM SELF-CONTAINED (RSS3, 4 –SC-2B & 3B).....	26

Information contained in this manual covers models:

RSS3SC-2B RSS4SC-2B
RSS3SC-3B RSS4SC-3B

Including Hybrid Models



INTRODUCTION

Thank you for purchasing a Federal Industries display case. This manual contains important instructions for installing and servicing the RSS, Refrigerated Self-Service Merchandisers. A repair parts list and wiring diagram are also included in the manual. Read all of these documents carefully before installing or servicing your case.



NOTICE

Read this manual before installing your case. Keep this manual and refer to it before doing any service on the equipment. Failure to do so could result in personal injury or damage to the case.



NOTICE

Installation and service of the electrical components in the case must be performed by a licensed electrician.

The portions of this manual covering electrical components contain technical instructions intended only for persons qualified to perform electrical work.



DANGER

Improper or faulty hookup of electrical components in the case can result in severe injury or death.

All electrical wiring hookups must be done in accordance with all applicable local, regional, or national standards.

Serial Number

Record the model and serial numbers of the case for easy reference. Always refer to both model and serial numbers in your correspondence regarding the case.

Case Model _____ Serial Number _____
Condensing Unit Model _____ Serial Number _____

This manual cannot cover every installation, use or service situation. If you need additional information, call or write us:

Warranty/Technical Service Department
Federal Industries
Toll Free (800)356-4206
WI Phone (608)424-3331
service@federalind.com

WARNING LABELS & SAFETY INSTRUCTIONS



This is the safety-alert symbol. When you see this symbol on your case or in the manual, be alert to the potential for personal injury or damage to your equipment.

Be sure you understand all safety messages and always follow recommended precautions and safe operating practices.



Notice to Employers

You must make sure that everyone who installs, uses, or services your case is thoroughly familiar with all safety information and procedures.

Important safety information is presented in this section and throughout the manual. The following signal words are used in the warnings and safety messages:

- DANGER:** Severe injury or death will occur if you ignore the message.
- WARNING:** Severe injury or death can occur if you ignore the message.
- CAUTION:** Minor injury or damage to your case can occur if you ignore the message.
- NOTICE:** This is important installation, operation, or service information. If you ignore the message, you may damage your case.

The warning and safety labels shown throughout this manual are placed on your Federal Industries case at the factory. Follow all warning label instructions. If any warning or safety labels become lost or damaged, call our customer service department at 1(800)356-4206 for replacements.

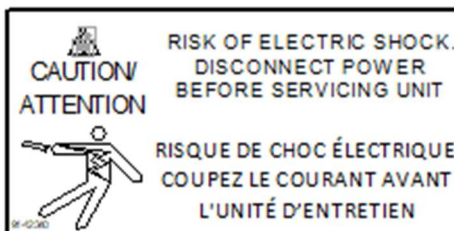

This label is located on the back of the case and on the front of the case behind the access panel.



This label is located below the display pan.

DANGER – Risk of fire or explosion. Flammable refrigerant used. Consult repair manual/owner's guide before attempting to service this product. all safety precautions must be followed 91-21814

DANGER — Risque d'incendie ou d'explosion. Fluide frigorigène utilisé. Consulter le guide propriétaire ou le manuel de réparations avant de d'essayer d'installer ou de réparer ce produit. Toutes les précautions de sécurité doivent être suivies. 91-21814

This label is located by condensing unit

REFRIGERATION WARNING

INSTALLATION-REPAIR-DECOMMISSIONING



This is the Danger-Flammable symbol. When you see this symbol on your case or in the manual, be alert to the potential for risk of fire or explosion.

Be sure you understand all safety messages and always follow recommended precautions and safe operating procedures.

DANGER



Risk of fire or explosion. Flammable refrigerant used. To be repaired only by trained service personnel. Do not puncture refrigerant tubing. Dispose of properly in accordance with federal or local regulations

Consult repair manual/owner's guide before attempting to service this product. All safety precautions must be followed.

Follow handling instructions carefully in compliance with national regulations.

Auxiliary devices which may be ignition sources shall not be installed in the ductwork, other than auxiliary devices listed for use with the specific appliance.

Do not store explosive substances (such as aerosol cans with a flammable propellant) in this case.

Do not use an electrical appliance INSIDE the food storage compartments unless its type is recommended by manufacturer.

Flammable refrigerant type specified on case nameplate is on the serial label.

APPLIES TO R290 REFRIGERANT MODELS ONLY! Contains a charge of R290 refrigerant with a lower flammability limit (LFL) of .038kg/m³. See table for amount of charge.

WARNING

- Do not use means to accelerate the defrosting process or to clean, other than those recommended by the manufacturer.
- The appliance shall be stored in a room without continuously operating ignition sources
For example: open flames, an operating gas appliance or an operating electric heater.
- Do not pierce or burn.
- Be aware that refrigerants may not contain an odor.

MISE EN GARDE

- Ne pas utiliser de moyens autres que ceux recommandés par le fabricant pour accélérer le processus de dégivrage ou pour nettoyer l'appareil.
- L'appareil doit être entreposé dans un local ne contenant pas de sources d'inflammation permanentes (flammes nues, appareil à gaz ou dispositif de chauffage électrique en fonctionnement, par exemple).
- Ne pas percer ou brûler.
- Attention, les fluides frigorigènes peuvent ne pas dégager d'odeur.

3. Qualification: All refrigeration and electrical maintenance, service, and repair must be performed by a Certified Technician that is trained in the required flammable refrigerants safety procedures. Technicians must read the entire section “REFRIGERATION WARNINGS SECTION” of this manual.

Including but not limited to the following:

- a) breaking into the refrigerating circuit.
- b) opening of sealed components.
- c) opening of ventilated enclosures.

4. Checks to Area: Prior to beginning work on systems containing FLAMMABLE REFRIGERANTS, safety checks are necessary to ensure that the risk of ignition is minimized prior to conducting work on the system.

- Capacitors are discharged: this shall be done in a safe manner to avoid possibility of sparking.
- No live electrical components and wiring are exposed while charging, recovering or purging the system.
- Continuity of earth bonding.

-Work shall be undertaken under a controlled procedure to minimize the risk of a flammable gas or vapor being present while the work is being performed.

-All maintenance staff and others working in the local area shall be instructed on the nature of the work being carried out. Work in confined spaces shall be avoided.

-The area shall be checked with an appropriate refrigerant detector prior to and during work, to ensure the technician is aware of potentially toxic or flammable atmospheres. Ensure that the leak detection equipment being used is suitable for use with all applicable refrigerants, i.e., non-sparking, adequately sealed, or intrinsically safe.

-If any hot work is to be conducted on the refrigerating equipment or any associated parts, appropriate fire extinguishing equipment shall be available on hand. A dry chemical or CO2 fire extinguisher should be adjacent to the charging area.

-No person carrying out work in relation to a REFRIGERATING SYSTEM which involves exposing any pipe work shall use any sources of ignition in such a manner that it may lead to the risk of fire or explosion. All possible ignition sources, including cigarette smoking, should be kept sufficiently far away from the site of installation, repairing, removing and disposal, during which refrigerant can possibly be released to the surrounding space. Prior to work taking place, the area around the equipment shall be surveyed to make sure that there are no flammable hazards or ignition risks. "No Smoking" signs shall be displayed.

-Ensure that the area is in the open or that it is adequately ventilated before breaking into the system or conducting any hot work. A degree of ventilation shall continue during the period that the work is carried out. The ventilation should safely disperse any released refrigerant and preferably expel it externally into the atmosphere.

-Where electrical components are being changed, they shall be fit for the purpose and to the correct specification so as to minimize the risk of possible ignition due to incorrect parts. At all times, the manufacturer's maintenance and service guidelines shall be followed. If in doubt, consult the manufacturer's technical department for assistance. The following checks shall be applied to installations using flammable refrigerants:

- a) the actual REFRIGERANT CHARGE is in accordance with the room size within which the refrigerant containing parts are installed.
- b) The ventilation machinery and outlets are operating adequately and are not obstructed.
- c) Markings of the equipment continue to be visible and legible. Markings and signs that are illegible shall be corrected.
- d) Refrigerating pipes or components are installed in a position where they are unlikely to be exposed to any substance which may corrode refrigerant containing

-Repair and maintenance to electrical components shall include initial safety checks and component inspection procedures. If a fault exists that could compromise safety, then no electrical supply shall be connected to the circuit until it is satisfactorily dealt with. If the fault cannot be corrected immediately but it is necessary to continue operation, an adequate temporary solution should be used. This shall be reported to the owner of the Initial safety checks shall include:

5. Repairs to sealed components

-During repairs to sealed components, all electrical supplies shall be disconnected from the equipment being worked upon prior to any removal of sealed covers, etc. If it is necessary to have an electrical supply to equipment during servicing, then a permanently operating form of leak detection shall be located at the most critical point to warn of a potentially hazardous situation.

-Particular attention shall be paid to the following to ensure that by working on electrical components, the casing is not altered in such a way that the level of protection is affected. This shall include damage to cables, excessive number of connections, terminals not made to original specification, damage to seals, incorrect fitting of glands, etc. Ensure that the apparatus is mounted securely.

Ensure that seals or sealing materials have not degraded to the point that they no longer serve the purpose of preventing the egress of flammable atmospheres. Replacement parts shall be in accordance with the manufacturer's specifications.

-Do not apply any permanent inductive or capacitance loads to the circuit without ensuring that this will not exceed the permissible voltage and current permitted for the equipment in use. NOTE The use of silicon sealants can inhibit the effectiveness of some types of leak detection equipment. Intrinsically safe components do not have to be isolated prior to working on them.

8. Detection of flammable refrigerants: Under no circumstances shall potential ignition sources be used in the searching for or detection of refrigerant leaks. A halide torch (or any other detector using a naked flame) shall not be used.

The following leak detection methods are deemed acceptable for all refrigerant systems:

-Electronic leak detectors may be used to detect refrigerant leaks but, in the case of FLAMMABLE REFRIGERANTS, the sensitivity might not be adequate or might need recalibration. (Detection equipment shall be calibrated in a refrigerant-free area.) Ensure that the detector is not a potential source of ignition and is suitable for the refrigerant used. Leak detection equipment shall be set at a percentage of the LFL of the refrigerant and shall be calibrated to the refrigerant employed, and the appropriate percentage of gas (25 % maximum) is confirmed.

-Leak detection fluids are also suitable for use with most refrigerants but the use of detergents containing chlorine shall be avoided as the chlorine can react with the refrigerant and corrode the copper pipework.

NOTE Examples of leak detection fluids are

- bubble method,
- fluorescent method agents.

If a leak is suspected, all naked flames shall be removed/extinguished.

If a leakage of refrigerant is found which requires brazing, all the refrigerants shall be recovered from the system, or isolated (by means of shut off valves) in a part of the system remote from the leak.

9. Removal and Evacuation: When breaking into the refrigerant circuit to make repairs-or for any other purpose-conventional procedures shall be used. However, for flammable refrigerants it is important that the best practice be followed, since flammability is a consideration. The following procedure shall be adhered to:

- a. Safely remove refrigerant following local and national regulations.
- b. Purge the circuit with inert gas.
- c. Evacuate (optional for A2L).
- d. Purge with inert gas (optional for A2L).
- e. Open the circuit by cutting or brazing.

The refrigerant change shall be recovered into the correct recovery cylinders if venting is not allowed by local and national codes. For appliances containing flammable refrigerants, the system shall be purged with oxygen-free nitrogen to render the appliance safe for flammable refrigerants. This process might need to be repeated several times. Compressed air or oxygen shall not be used for purging refrigerant systems. For appliances containing flammable refrigerants, refrigerant purging shall be achieved by breaking the vacuum in the system with oxygen-free nitrogen and continuing to fill until the working pressure is achieved, then venting to atmosphere, and finally pulling down to a vacuum (optional for A2L). This process shall be repeated until no refrigerant is within the system (optional for A2L). When the final oxygen-free nitrogen change is used, the system shall be vented down to atmospheric pressure to enable work to take place. Ensure that the outlet for the vacuum pump is not close to any potential ignition sources and that ventilation is available.

10. Charging procedures: In addition to conventional charging procedures, the following requirements shall be followed.

- a. Ensure that contamination of different refrigerants does not occur when using charging equipment. Hoses or lines shall be as short as possible to minimize the amount of refrigerant contained in them.
- b. Cylinders should be kept in an appropriate position according to the instructions.
- c. Ensure that the REFRIGERATING SYSTEM is earthed prior to charging the system with refrigerant.
- d. Label the system when charging is complete (if not already).
- e. Extreme care shall be taken not to overfill the REFRIGERATING SYSTEM.

11. Decommissioning: Before carrying out this procedure, it is essential that the technician is completely familiar with the equipment and all its details. It is recommended good practice that all refrigerants are recovered safely. Prior to the task being carried out, an oil and refrigerant sample shall be taken in case analysis is required prior to re-use of recovered refrigerant. It is essential that electrical power is available before the task commences.

- a. Become familiar with the equipment and its operation.
- b. Isolate the system electrically.
- c. Before attempting the procedure, ensure that:
 - i. Mechanical handling equipment is available, if required, for handling refrigerant cylinders.
 - ii. All personal protective equipment is available and is being used correctly.
 - iii. The recovery process is supervised at all times by a competent person.
 - iv. Recovery equipment and cylinders conform to the appropriate standards.
- d. Pump down the refrigerant system, if possible.
- e. If a vacuum is not possible, make a manifold so that refrigerant can be removed from various parts of the system.
- f. Make sure that the cylinder is situated on the scales before recovery takes place.
- g. Start the recovery machine and operate in accordance with instructions.

- h. Do not overfill cylinders (no more than 80% volume liquid charge).
- i. Do not exceed the maximum working pressure of the cylinder, even temporarily.
- j. When the cylinders have been filled correctly and the process completed, make sure that the cylinders and the equipment are removed from the site properly and all isolation valves on the equipment are closed off.
- k. Recovered refrigerant shall not be charged into another refrigerating system unless it has been cleaned and checked.

12. Labeling: Equipment shall be labeled stating that it has been de-commissioned and emptied of refrigerant. The label shall be dated and signed. For appliances containing flammable refrigerants, ensure that there are labels on the equipment stating the equipment contains flammable refrigerant.

13.Recovery: When removing the refrigerant from a system, either for servicing or decommissioning, it is recommended good practice that all refrigerants are removed safely. When transferring refrigerant into cylinders, ensure that only appropriate refrigerant recovery cylinders are employed. Ensure that the correct number of cylinders for holding the total system charge is available. All cylinders to be used are designated for the recovered refrigerant and labeled for that refrigerant (i.e., special cylinders for the recovery of refrigerant). Cylinders shall be complete with pressure-relief valve and associated shut-off valve in good working order. Empty recovery cylinders are evacuated and, if possible, cooled before recovery occurs.

The recovery equipment shall be in good working order with a set of instructions concerning the equipment that is at hand and shall be suitable for the recovery of all appropriate refrigerants including, when applicable, FLAMMABLE REFRIGERANTS. In addition, a set of calibrated weighing scales shall be available and in good working order. Hoses shall be complete with leak-free disconnect coupling and in good condition. Before using the recovery machine, check that it is in satisfactory working order, has been properly maintained and that any associated electrical components are sealed to prevent ignition in the event of refrigerant release. Consult manufacturer if in doubt.

The recovered refrigerant shall be returned to the refrigerant supplier in the correct recovery cylinder, and the relevant waste transfer note arranged. Do not mix refrigerants in recovery units and especially not in cylinders.

If compressors or compressor oils are to be removed, ensure that they have been evacuated to an acceptable level to make certain that FLAMMABLE REFRIGERANT does not remain within the lubricant. The evacuation process shall be carried out prior to returning the compressor to the suppliers. Only electric heating to the compressor body shall be employed to accelerate this process. When oil is drained from a system, it shall be carried out safely.

PRE-INSTALLATION PROCEDURES

Inspection for Shipping Damage

You are responsible for filing all freight claims with the delivering truck line. Inspect all cartons and crates for damage as soon as they arrive. If damage is noted to shipping crates or cartons or if a shortage is found, note this on the bill of lading (all copies) prior to signing.

If damage is discovered when the case is uncrated, immediately call the delivering truck line and follow up the call with a written report indicating concealed damage to your shipment. Ask for an immediate inspection of your concealed damage item. Crating material must be retained to show the inspector from the truck line.

INSTALLATION INSTRUCTIONS

IMPORTANT: Read this Section of this manual located on page 5.
“REFRIGERATION WARNING & INSTALLATION-REPAIR-DECOMMISSIONING”
All refrigeration and electrical work must be performed by certified technicians.

The installation of the appliance and the refrigerant must only be performed by Federals approved Service or suitably qualified person.

Appliance to be installed in accordance with safety standards ANSI/ASHREA 15.
The appliance shall not be installed in public corridors or lobbies.

This case is designed for a class 2 environment.

<u>Test room climate class</u>	<u>Dry bulb temperature [°F]</u>	<u>Relative Humidity [%]</u>	<u>Dew point [°F]</u>	<u>Water vapour mass in dry air [lbm water/lbm air]</u>	<u>Required Test Lab Temperature [°F]</u>
2.0	71.6	65	59.36	0.0108	89.6

NSF TYPE 1 Temperature cannot exceed 75 deg F and 55% humidity.

Locating the Display Case

The case should be located where it is not subjected to the direct rays of the sun, heating ducts, grills, radiators, or ceiling fans, nor should it be located near open doors or main door entrances. Avoid locations where there is excessive air movement or air disturbances and avoid high humidity locations such as near cases with water misting or fogging devices.

The case requires a minimum of six (6”) inch clearance at the rear of the unit for air discharge. Do not locate case with back tight against a wall. No clearance is needed on the sides of the unit.

Leveling the Case

The case must be level for proper drainage of defrost water to the condensate evaporator or floor drain. The case can be leveled by placing metal shims under welded steel frame as required.

To comply with NSFI requirements, the base of the unit should be sealed to the floor with NSFI listed sealant after installing and leveling unless a minimum of 6" high legs or casters are provided.

Grill Removal



DANGER: Electrical shock hazard. Do not operate unit with panels removed.

The front and rear grill require removal for case installation. Both grills are secured with self-tapping machine screws. To remove front grill remove the two screws, grille lifts up and tilts out at the bottom. The screws in the front grille are for shipping only; they do not need to be replaced after removal.

Both grills must be in place for proper operation of the case. Grills must be reinstalled after initial case installation.

Condensate Evaporator

IMPORTANT: Read this Section of this manual located on page 5.

“REFRIGERATION WARNING & INSTALLATION-REPAIR-DECOMMISSIONING”

All refrigeration and electrical work must be performed by certified technicians.



NOTICE: Steam from the condensate evaporator may be visible around the base of the merchandiser during normal operation.

Do not use other means to defrost coil other than recommended by manufacturing

This merchandiser may be furnished with an electric condensate evaporator, or an electric condensate pump. Plumbing connections are not required, unless merchandiser is specifically ordered without a condensate evaporator or pump.

The condensate evaporator can be removed from the merchandiser, and the condensate drain can be plumbed to an external drain to conserve energy. To remove the condensate evaporator, disconnect the wires at the condensate evaporator. This must be done by a qualified electrician.

This is an open merchandiser and can produce a large amount of condensate water. To ensure that adequate evaporator capacity is available, a high wattage heater is used.

Make sure that the condensate drain line has not been dislodged during shipment and that the drain trap terminates properly over the water reservoir

ELECTRICAL INFORMATION & GROUNDING

IMPORTANT: Read this Section of this manual located on page 5. “REFRIGERATION WARNING & INSTALLATION-REPAIR-DECOMMISSIONING”
All refrigeration and electrical work must be performed by certified technicians.

This Case Must Be Grounded



DANGER: Improper or faulty hookup of electrical components in the display case can result in severe injury or death.

All of the case electrical connections must be performed only by a licensed electrician.

All electrical wiring hookups must be done in accordance with all applicable local, regional, or national standards.

A separate circuit for each case is recommended to avoid the possibility of other appliances on the same circuit from overloading the circuit and causing malfunction.

The electrical service must be grounded upon installation.

This unit is designed for permanent connection to a power source. See the electrical data plate at the rear of the unit for proper circuit size and wire ampacity.

On self-contained models two (2) power supplies are required. Connect a separate 120 volt, 60 HZ, 1 phase power supply to the display case junction box and a separate 120 volt, 60 HZ, 1 phase power supply to the condensate evaporator junction box.

Cases with optional cord & plug (RSS3 & RSS4) require (1) 120v, 60hz, 1 phase 20 amp power supply, a lower wattage condensate pan or pump is used.



CAUTION! GFCI BREAKER USE REQUIREMENT
If N.E.C. (National Electric Code) or your local code requires GFCI (Ground Fault Circuit Interrupter) protection, you **MUST** use a GFCI breaker in lieu of a GFCI receptacle.

OPERATING INSTRUCTIONS

Controls

Refrigeration System Power Switch

This switch is located in the back of the unit and is accessible through an oval slot. This switch controls the refrigeration system, the evaporator fans, lights, and anti-sweat heaters. It does not control the power to the condensate water evaporator.

Light Switch (Optional Case Light)

If the unit is supplied with the optional light, it can be turned on and off by a switch located at the top light housing.



Temperature Control

Located in the left front behind the base grille on front air intake and discharge and hybrid display case or on the back right on rear air intake and discharge cases, the temperature control allows the user to adjust the temperature of the display merchandiser to their needs.

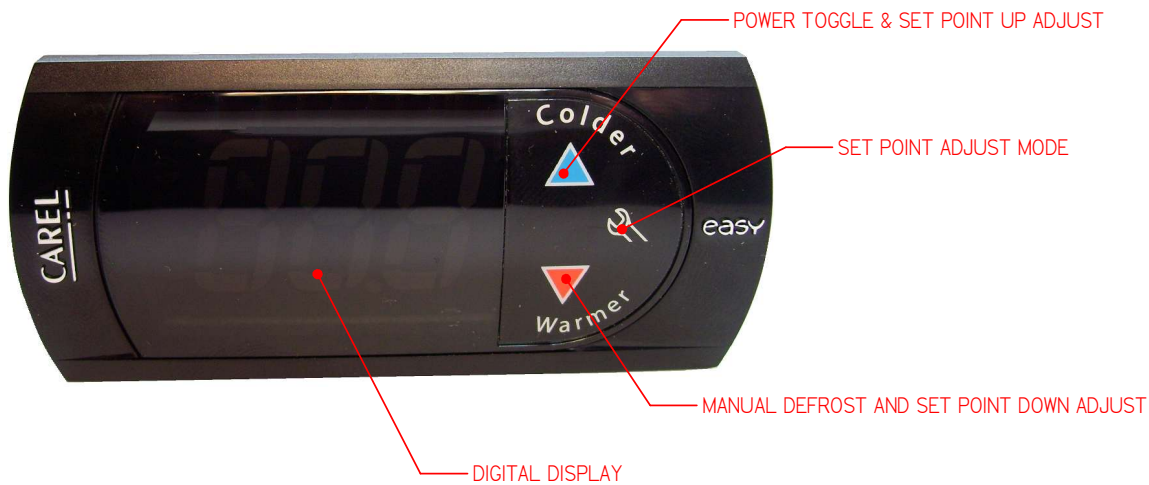
USING THE ELECTRONIC CONTROL

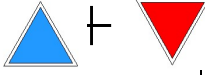

Button and Display Overview

	Press and hold this button for 3s to turn system on (if off) or off (if on). Also used to adjust set point when in set point adjust mode
	Press to enter set point adjust mode, confirm set point changes, and mute alarms.
	Press and hold this button for 3 seconds to initiate a manual defrost (and cancel defrost if initiated), also adjusts set point down when in set point adjust mode
	Press both buttons simultaneously to check air stream probe temperature. This is not an indicator of product temperature.

Powering on control

To turn power on to the refrigeration system press and hold, for three seconds, the blue up arrow on the control's keypad. The keypad will read "On" while the button is depressed. When the system powers on, the display will read the current set point (a number "1" through "9"). The orange compressor run indicator will illuminate on the display.



Adjusting the set point

The set point is what determines how cold the display case will hold food and beverage. To adjust the set point press and hold the wrench button until the display begins to flash a number (three seconds). Then use the up and down arrows of the keypad to scroll through the set point options. There are nine (9) available set points, the higher the number of the set point name, the colder the display case will run, with setting "9" being the coldest and setting "1" being the warmest. Once you have chosen your desired setting press the wrench button again to confirm your choice.



Entering manual defrost mode

In order to initiate a manual defrost press and hold the red down arrow for 3s. The control will read “dEF” while the button is being held. The defrost is initiated when the orange snowflake appears on the control display.



Error codes

It is possible for error codes to be displayed on the control screen. In the event of a malfunction an alarm will sound and a red ringing bell will be displayed on the screen. An error code or codes will flash intermittently on the display. If there are multiple codes, the display will continuously cycle through them. The following photo shows error code “E0” as an example next to the red bell.



You may mute the alarm by pressing and releasing the wrench button. The red ringing bell and all error codes will still be displayed. When the fault is remedied the control will return to normal operation and will automatically clear the codes from the display.

INITIAL STARTUP

After all the checks outlined in the installation section of this manual have been made, the case is ready to be put into service. Turn on the Power at the breaker box and flip the Power Switch and Light Switch on unit to the on position. Also ensure that the control is powered on as described above.

At start up from a warm unit, it is recommended that the temperature control is set to a warmer setting, such as 1. After the unit has gone through several cycles, adjust the control to a mid-range setting, then to a colder setting if necessary to maintain desired product temperature



NOTICE:

This refrigerated display case is designed to operate in a maximum environment of 75°F (23.9°C) and 55% relative humidity. Exceeding these limits will cause poor case performance and excessive sweating.

Placing Product in Case

Do not overload the case with product to a point where the top air discharge grill or the bottom air intake grill are blocked or where the air curtain created by the discharge air is blocked. The following diagram shows proper product loading.

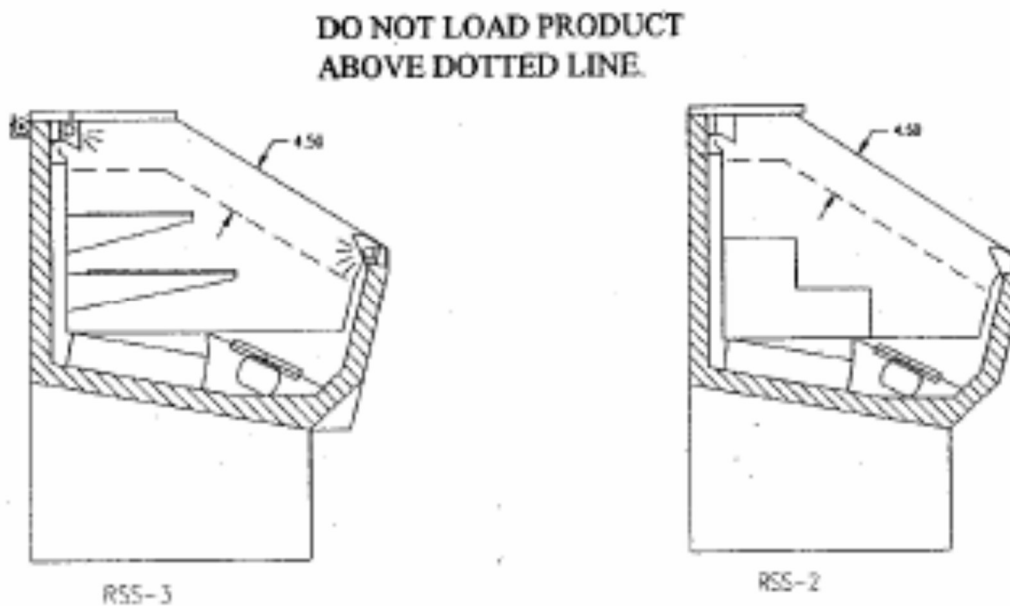

Open refrigerated merchandisers are not intended as storage refrigerators and will not “pull down” product that is warm or at room temperature. Load case interior with only pre-chilled product.

Periodic Maintenance

IMPORTANT: Read this Section of this manual located on page 5.

“REFRIGERATION WARNING & INSTALLATION-REPAIR-DECOMMISSIONING”

All refrigeration and electrical work must be performed by certified technicians.

Cleaning Condenser Coil

Turn power switch “off”

Remove front grill on front air intake models, rear grill on rear intake models, and vacuum the front surface of the condenser coil. Replace grill when done.

This should be done every one or two months as necessary.

Cleaning Case Interior

Turn power switch “off”

Clean interior surfaces with mild detergent and water. Do not use abrasive cleansers on case interior.

Step pans or shelving may be removed from the case for easy cleaning.

SERVICE INFORMATION

Before any service work is performed on the case, make sure all power is disconnected to the case.

IMPORTANT: Read this Section of this manual located on page 5.
“REFRIGERATION WARNING & INSTALLATION-REPAIR-DECOMMISSIONING”
All refrigeration and electrical work must be performed by certified technicians.

To find a service company in your area, please visit our website at www.federalindustries.com. There you can also find self-service tools to help you get the answers you need faster!

For Warranty Service Requests & ALL Technical Support please contact:

- Phone: (800) 356-4206 and choose the Tech Support/Warranty Option
- Email: Service@federalind.com

For Warranty Compressors please contact the Parts Department:

- Phone: (800) 356-4206 and choose the Warranty Parts Option
- Email: Parts@Federalind.com



Partstown

Federal Industries has partnered with Parts Town for ALL Non-Warranty Part Identification, Pricing, Lead Times, Orders & Freight Quotes. Please contact Parts Town directly if you need parts:

- Website: PartsTown.com
- Email: CustomerService@PartsTown.com
- Phone: 833-809-8188

Pre-Service Checklist

You may avoid the cost and inconvenience of an unnecessary service call by first reviewing this checklist of frequently encountered situations that can cause unsatisfactory case performance.



WARNING:

Before servicing case turn off power at the main breaker of fuse box.

Pre-Service Checklist

Case Does Not Operate

Check for disconnected power supply.

Check that power switch is “on”.



CAUTION! GFCI BREAKER USE REQUIREMENT
If N.E.C. (National Electric Code) or your local code requires GFCI (Ground Fault Circuit Interrupter) protection, you **MUST** use a GFCI breaker in lieu of a GFCI receptacle.

Case Temperature Too Warm

Check that top air discharge opening and/or bottom air intake grille are not blocked.

Check for a blocked or dirty condenser coil.

Check that there are no outside air disturbances in or around case. These disturbances can be caused by nearby doors or entrances, overhead ceiling fans, or air diffuser vents, direct sunlight or other heat sources. The location of open refrigerated merchandisers is critical to case performance.

Make sure that warm product is not being placed inside case. All products must be pre-chilled prior to loading for proper case performance.

Check temperature/pressure control for proper settings.

Check cold air flow. Lack of, or no air flow may indicate a blocked evaporator coil or defective evaporator fan motor. Contact a qualified service company if there is no air flow inside the case.

Lights Do Not Operate (Optional Equipment)

Check that light switch is “on”.

Check that light bulb(s) are properly seated in light holders.

Overflow of Condensate Evaporator

Check that there is a power supply to the condensate evaporator assembly. On self-contained models this is on a separate electrical circuit.

Check that the drain line is properly located over the water reservoir.

Check room ambient conditions. The room environment should not exceed 75F ambient and 55% humidity conditions.

Special Service Situations

IMPORTANT: Read this Section of this manual located on page 5.

“REFRIGERATION WARNING & INSTALLATION-REPAIR-DECOMMISSIONING”

All refrigeration and electrical work must be performed by certified technicians

There are rare occasions when the refrigerant charge must be evacuated from a case in order to perform service work. In those situations, Federal Industries recommends that the refrigerant charge be evacuated into a recovery system to prevent the possibility of hydrochlorofluorocarbons (HCFC's) from being released into the atmosphere. The release of HCFC's into the atmosphere is a potential source of global warming.

If moisture or liquid is observed around or under a Federal Industries case, an immediate investigation should be made by qualified personnel to determine the source of moisture or liquid. The investigation made should determine if the case is malfunctioning or if there is a simple housekeeping problem.

Moisture or liquid around or under a case is a potential slip/fall hazard for persons walking by or working in the general area of the case. Any case malfunction or housekeeping problem that creates a slip/fall hazard around or under a case should be corrected immediately.

SALE & DISPOSAL

Owner Responsibility

IMPORTANT: Read this Section of this manual located on page 5.
“REFRIGERATION WARNING & INSTALLATION-REPAIR-DECOMMISSIONING”
All refrigeration and electrical work must be performed by certified technicians

If you sell or give away your Federal Industries case, you must make sure that all safety labels and the Installation-Service Manual are included with it. If you need replacement labels or manuals, Federal Industries will provide them free of charge. Contact the Customer Service Department at Federal Industries at 1(800)356-4206.

The Customer Service Department at Federal Industries should be contacted at the time of sale or disposal of your case so records may be kept of its new location.

If you sell or give away your Federal Industries case and you evacuate the refrigerant charge before shipment, Federal Industries recommends that the charge be evacuated into a recovery system to reduce the possibility of HCFC's from being released into the atmosphere. The release of HCFC's into the atmosphere is a potential source of ozone depletion.

Refrigerant Recovery/Recycling/Disposal

When recycling or discarding case, refrigerants **MUST BE** handled according to local, state and federal codes, requirements and regulations.

If disposing of a refrigerated case that uses ozone depleting chemicals in its refrigeration system, make sure the refrigerant is removed by a qualified service technician and properly disposed of.

If you intentionally release refrigerant into the atmosphere, you may be subject to fines or other penalties (under regulation mandated by environmental regulators and/or legislative edict.)

REFRIGERATION & ELECTRICAL DATA

SELF-CONTAINED MODELS

Model	RSS3SC-2B RSS3SC-3B	RSS4SC-2B RSS4SC-3B
Refrigerant	R290	R290

ALL MODELS ARE 120 VOLTS, 1 PHASE, 60 HERTZ, 2 WIRE

	AMPS	AMPS
Compressor		
RLA	9	8.3
LRA	32	41.5
Condenser Fan Motor	0.5	0.53
Evaporator Fan Ea. (2)	0.2	0.2
Anti-Sweat Heater	0.1	0.1
Lights	0.26	0.26
Condensate Evaporator *(Separate Power Supply)	5.0	*10.0
Condensate pump (optional)	1.0	1.0

Refer to the rating plate data attached to the rear of the case for Maximum Fuse Size and Minimum Circuit Ampacity.

REPLACEMENT PARTS

MODELS RSS3 & RSS4 INCLUDING HYBRID

Part Description	Part Number	
	RSS3	RSS4
Refrigeration System		
Condensing Unit (Self-Contained Only)	30-21725	30-21726
Compressor (Replacement)	30-21725-COMP	30-21726-COMP
Refrigeration Control (Electronic)	32-19864-29	32-19864-29
Control Probe (2)	32-19866	32-19866
High Pressure Switch	32-21850	32-21850
Evaporator Coil	33-10946-20	33-50042-20
Expansion Valve	32-21751	32-21751
Evaporator Fan Motor	41-21572-10	41-21237-11
Toggle Switch	41-10974	41-10974
Anti-Sweat Heater	43-14892	43-14891
Terminal Block	45-11056	45-11056
Thermometer	32-13662	32-13662
Condensate Evaporator		
Heating Element 600W	40-19331	40-19331
OBS Entire Assembly 600W	SA5406-1	SA5406-1
Entire Assembly 600W replaces SA5406-1	SA5406-4	SA5406-4
Condensate Pan Bracket use with SA5406-4	M19017-4 qty 2	M19017-4 qty 2
OBS Entire Assembly 1200W	SA5406-12	SA5406-12
Entire Assembly 1200W replaces SA5406-12	SA5406-15	SA5406-15
Condensate Pan Bracket use with SA5406-15	M19017-4 qty 2	M19017-4 qty 2
Condensate Steam Notice Tag	91-13038	91-13038
Optional Condensate Pump		
Condensate Pump 120V	47-15686	47-15686
Hose 50'	15-17337	50-17337
Standard Lights		
LED Light 24V	42-20871-25C35 (2)	42-20871-38C35 (2)
Power Supply 24V	39-20986	39-20986
Light Clip	67-20869 (4)	67-20869 (4)
Light Switch	41-21765	41-21765
Cord LED 12"	43-20860-1B	43-20860-1B
SHELVING		
Shelf Metal 10"	M12738-3A	M12738-2A
Shelf Metal 14"	M12739-3A	M12739-2A
Shelf Wire 10"	63-13904-1	63-13896-1
Shelf Wire 14"	63-13905-1	63-13897-1
Shelf Glass 10"	52-13616	52-15006
Shelf Glass 14"	52-13617	52-15007
Glass Shelf Clips	67-72582	67-72582
Shelf Bracket 10"	67-17732-1	67-17732-1
Shelf Bracket 14"	67-17732-2	67-17732-2
Shelf Standard	M14679-2A	M14679-2A
Wire Steps	63-11713	63-14961
Step Riser Bottom 5 ¼ x 18 ½ x length	SA3124-1	SA3124-2
Step Riser Top 5 ¼ x 9 ¼ x length	SA3123-1	SA3123-2
Step Riser Bottom 5 x 15 x length	SA4079-1	SA4079-2
Step Riser Top 5x7 ½ x length	SA4078-1	SA4078-2
Miscellaneous Components		
Night Curtain	65-19459	65-19460
End Glass Clear	50-19414-1	50-19414-1
End Glass Reflective Right Hand	50-19414-3R	50-19414-3R
End Glass Reflective Left Hand	50-19414-3L	50-19414-3L
Anti-Sweat Heater	43-14892	43-14891



WIRING DIAGRAM- RSS3, 4 SC-2B & -3B

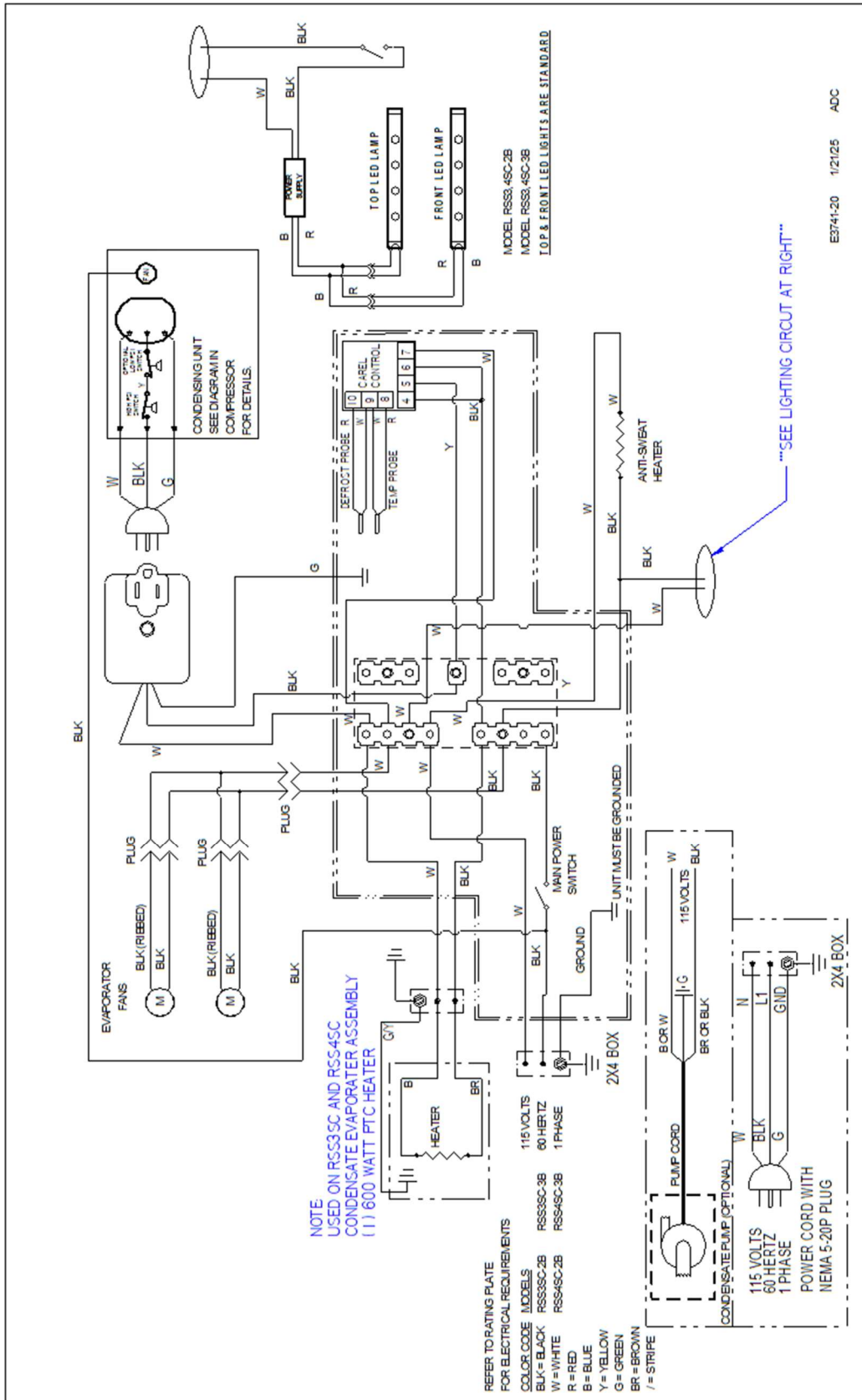

California Residents Only.

 WARNING

This product can expose you to chemicals including chromium which is known to the State of California to cause cancer and birth defects or other reproductive harm. For more information go to www.P65Warnings.ca.gov

