



HOSHIZAKI

Parts List

Refrigerated Kitchen Equipment
Steelheart A Series

Models

Undercounter
Worktop
Prep Table



hoshizakiamerica.com

Number: 71387
Issued: 10-25-2018
Revised: 6-11-2021

CONTENTS

Auxiliary Codes.....	3
Model Codes	11
A. Main Assembly	12
UR27, WR27, SR27, UF27, and WF27 Undercounter, Worktop, and Prep Table.....	12
UR36, WR36, and SR36 Undercounter, Worktop, and Prep Table	15
UR48, WR48, SR48, UF48, and WF48 Undercounter, Worktop, and Prep Table	17
UR60, WR60, SR60, UF60, and WF60 Undercounter, Worktop, and Prep Table	20
UR72, WR72, and SR72 Undercounter, Worktop, and Prep Table	24
B. Refrigeration Circuit.....	28
UR27, WR27, and SR27 Undercounter, Worktop, and Prep Table	28
UF27 and WF27 Undercounter and Worktop	30
UR36, WR36, and SR36 Undercounter, Worktop, and Prep Table	32
UR48, WR48, and SR48 Undercounter, Worktop, and Prep Table	34
UF48 and WF48 Undercounter and Worktop	36
UR60, WR60, and SR60 Undercounter, Worktop, and Prep Table	38
UF60 and WF60 Undercounter and Worktop	40
UR72, WR72, and SR72 Undercounter, Worktop, Prep Table	42
C. Door-Right Hinged.....	44
D. Door-Left Hinged	46
E. Door-Right Glass Door Hinged.....	48
F. Door-Left Glass Door Hinged	49
G. Drawer.....	50
H. Accessories & Labels	52

Auxiliary Codes

UR27A

H-5 October 2018
J-5 January 2019
J-6 June 2019
J-7 July 2019
K-5 January 2020
L-5 January 2021

UR27A-GLP01

H-5 May 2018
J-5 April 2019
J-6 June 2019
J-7 July 2019
K-5 February 2020
L-5 January 2021

UR27A-01

H-5 October 2018
J-5 January 2019
J-7 July 2019
K-5 January 2020

UR27A-LP

H-5 February 2018
J-5 January 2019
J-6 June 2019
J-7 July 2019
K-5 January 2020
L-5 January 2021

UR27A-LPC

H-5 October 2018
J-5 January 2019
J-6 June 2019
J-7 July 2019
K-5 January 2020
L-5 January 2021

UR27A-LPW

J-5 April 2019
J-6 June 2019
J-7 July 2019
K-5 January 2020
L-5 January 2021

UR27A-D2

G-5 November 2017
H-5 October 2018
J-5 January 2019
J-6 June 2019
J-7 July 2019
K-5 January 2020
L-5 January 2021

WR27A

H-5 October 2018
J-5 January 2019
J-6 June 2019
J-7 July 2019
L-5 January 2021

WR27A-01

J-5 January 2019
K-5 February 2020

WR27A-D2

H-5 November 2018
J-5 January 2019
J-7 July 2019
K-5 January 2020

SR27A-8

H-5 October 2018
H-6 November 2018
J-5 January 2019
J-6 June 2019
J-7 July 2019
K-5 January 2020
L-5 January 2021

SR27A-8D2

H-5 October 2018
H-6 November 2018
J-5 January 2019
J-6 June 2019
J-7 August 2019
L-5 February 2021

SR27A-12M

H-5 October 2018
H-6 November 2018
J-5 January 2019
J-6 June 2019
J-7 July 2019
K-5 February 2020
L-5 February 2021

SR27A-12MD2

H-5 March 2018
H-6 November 2018
J-5 September 2019
K-5 February 2020
L-5 February 2021

Auxiliary Codes Continued

UF27A

G-5 July 2017
H-5 October 2018
J-5 January 2019
J-6 June 2019
J-7 July 2019
K-5 January 2020
L-5 January 2021

UF27A-GLP01

H-5 May 2018
J-5 January 2019
J-6 June 2019
J-7 August 2019
K-5 January 2020
L-5 March 2021

UF27A-01

J-5 February 2019
J-6 June 2019
J-7 July 2019
K-5 January 2020
L-5 January 2021

UF27A-LP

G-5 December 2017
H-5 October 2018
J-5 February 2019
J-6 June 2019
J-7 July 2019
K-5 February 2020
L-5 February 2021

UF27A-D2

H-5 October 2018
J-5 January 2019
J-6 June 2019
J-7 July 2019
K-5 January 2020
L-5 January 2021

WF27A

G-5 July 2017
H-5 October 2018
J-5 January 2019
J-6 June 2019
J-7 July 2019
K-5 January 2020
L-5 January 2021

WF27A-01

H-5 October 2018
J-5 February 2019
J-6 June 2019
J-7 July 2019
L-5 March 2021

WF27A-D2

G-5 September 2017
H-5 October 2018
J-5 January 2019
J-6 June 2019
J-7 July 2019
K-5 January 2020
L-5 January 2021

Auxiliary Codes Continued

UR36A

G-5 September 2017
H-5 November 2018
J-5 January 2019
J-6 June 2019
J-7 July 2019
K-5 January 2020
L-5 January 2021

UR36A-01

H-5 October 2018
J-5 March 2019
J-6 June 2019
K-5 January 2020
L-5 January 2021

WR36A

H-5 October 2018
J-5 February 2019
J-6 September 2019
L-5 January 2021

WR36A-01

J-5 February 2019
J-6 November 2019

SR36A-10

H-5 October 2018
H-6 November 2018
J-5 January 2019
J-7 August 2019
K-5 February 2020
L-5 January 2021

SR36A-15M

H-5 January 2018
H-6 October 2018
J-5 January 2019
J-6 June 2019
J-7 August 2019
J-8 September 2019
K-5 January 2020
L-5 January 2021

Auxiliary Codes Continued

UR48A

G-5 September 2017
H-5 October 2018
J-5 January 2019
J-7 July 2019
K-5 January 2020
L-5 January 2021

UR48A-GPL01

H-5 May 2018
J-5 April 2019
J-7 July 2019

UR48A-01

H-5 October 2018
J-5 February 2019
J-7 July 2019
K-5 January 2020
L-5 January 2021

UR48A-D2

H-5 November 2018
J-5 January 2019
J-7 July 2019
L-5 February 2021

UR48A-D4

G-5 November 2017
H-5 October 2018
J-5 January 2019
K-5 January 2020
L-5 January 2021

WR48A

G-5 September 2017
H-5 October 2018
J-5 January 2019
J-7 July 2019
K-5 January 2020
L-5 January 2021

WR48A-01

H-5 October 2018
J-5 March 2019
J-7 July 2019
K-5 January 2020

WR48A-D2

H-5 November 2018
J-5 March 2019
J-7 July 2019
L-5 February 2021

WR48A-D4

J-5 April 2019
J-7 July 2019
K-5 January 2020
L-5 January 2021

SR48A-8

H-5 October 2018
H-6 December 2018
J-5 January 2019
J-7 July 2019
K-5 February 2020
L-5 February 2021

SR48A-12

H-5 October 2018
H-6 November 2018
J-5 January 2019
J-7 July 2019
K-5 February 2020
L-5 January 2021

SR48A-12D2

H-5 October 2018
H-6 November 2018
J-5 January 2019
K-5 January 2020
L-5 February 2021

SR48A-12D4

H-5 October 2018
H-6 November 2018
J-5 January 2019
J-7 July 2019
K-5 January 2020
L-5 January 2021

SR48A-12M

H-6 November 2018
J-5 February 2019
J-8 November 2019
K-5 January 2020
L-5 January 2021

SR48A-18M

H-5 January 2018
H-6 November 2018
J-5 January 2019
J-7 July 2019
J-8 September 2019
K-5 January 2020
L-5 January 2021

Auxiliary Codes Continued

SR48A-18MD2

H-5 October 2018
H-6 November 2018
J-5 January 2019
J-7 July 2019
J-8 October 2019
L-5 May 2021

SR48A-18MD4

H-5 January 2018
H-6 November 2018
J-5 January 2019
J-7 July 2019
J-8 November 2019
K-5 January 2020
L-5 February 2021

UF48A

G-5 June 2017
H-5 October 2018
J-5 January 2019
J-6 June 2019
J-7 July 2019
K-5 January 2020
L-5 February 2021

UF48A-01

H-5 November 2018
J-5 March 2019
J-7 July 2019
K-5 January 2020
L-5 March 2021

UF48A-D4

G-5 September 2017
H-5 October 2018
J-5 January 2019
J-7 July 2019
K-5 February 2020
L-5 February 2021

WF48A

H-5 October 2018
J-5 January 2019
J-6 June 2019
J-7 August 2019
K-5 January 2020
L-5 February 2021

WF48A-01

H-5 October 2018
J-5 January 2019
J-7 August 2019
K-5 February 2020
L-5 March 2021

WF48A-D4

H-5 November 2018
J-5 January 2019
J-6 June 2019
J-7 August 2019
K-5 January 2020
L-5 February 2021

Auxiliary Codes Continued

UR60A

G-5 August 2017
H-5 October 2018
J-5 January 2019
J-6 May 2019
J-7 June 2019
J-8 July 2019
K-5 January 2020
L-5 January 2021

UR60A-01

J-6 May 2019
J-8 December 2019
K-5 February 2020
L-5 March 2021

UR60A-D2

H-5 October 2018
J-5 January 2019
J-7 June 2019
J-8 September 2019
K-5 January 2020
L-5 January 2021

UR60A-D4

G-5 October 2017
J-5 March 2019
J-6 May 2019
J-7 June 2019
J-8 July 2019
K-5 January 2020
L-5 January 2021

WR60A

H-5 October 2018
J-5 January 2019
J-6 May 2019
J-7 June 2019
J-8 July 2019
K-5 January 2020
L-5 January 2021

WR60A-01

J-5 February 2019
J-8 July 2019
K-5 January 2020
L-5 March 2021

WR60A-D2

J-5 March 2019
J-6 May 2019
J-8 July 2019
K-5 January 2020

WR60A-D4

H-5 October 2018
J-5 March 2019
J-6 May 2019
J-7 June 2019
J-8 August 2019
K-5 January 2020
L-5 January 2021

SR60A-8

H-5 October 2018
H-6 November 2018
J-5 January 2019
J-8 September 2019
K-5 February 2020
L-5 January 2021

SR60A-12

H-5 October 2018
H-6 November 2018
J-5 January 2019
J-7 June 2019
J-8 September 2019
K-5 January 2020
L-5 January 2021

SR60A-12M

J-5 January 2019
J-7 June 2019
J-8 August 2019
K-5 January 2020
L-5 February 2021

SR60A-16

H-5 October 2018
H-6 November 2018
J-5 January 2019
J-6 May 2019
J-7 June 2019
J-8 July 2019
K-5 January 2020
L-5 January 2021

SR60A-18M

H-5 October 2018
H-6 November 2018
J-5 January 2019
J-6 May 2019
J-7 June 2019
J-8 July 2019
K-5 January 2020
L-5 January 2021

Auxiliary Codes Continued

SR60A-24M

H-5 October 2018
H-6 November 2018
J-5 January 2019
J-6 May 2019
J-7 June 2019
J-8 July 2019
J-9 September 2019
K-5 January 2020
L-5 January 2021

SR60A-24MD2

H-5 October 2018
H-6 November 2018
J-5 March 2019
J-6 May 2019
J-7 June 2019
J-8 August 2019
J-9 December 2019

SR60A-24MD4

H-5 March 2018
H-6 November 2018
J-5 January 2019
J-6 May 2019
J-7 June 2019
J-8 July 2019
J-9 September 2019

UF60A

G-5 April 2017
H-5 October 2018
J-5 January 2019
J-7 June 2019
J-8 July 2019
K-5 January 2020

UF60A-01

H-5 October 2018
J-5 July 2019

WF60A

G-5 April 2017
H-5 October 2018
J-5 January 2019
J-6 May 2019
J-7 June 2019
J-8 July 2019
K-5 January 2020

WF60A-01

H-5 November 2018
J-5 July 2019

Auxiliary Codes Continued

UR72A

G-5 October 2017
H-5 November 2018
J-5 January 2019
J-6 May 2019
J-7 June 2019
J-8 July 2019
K-5 January 2020
L-5 January 2021

UR72A-01

J-5 July 2019
K-5 March 2020
L-5 January 2021

UR72A-D6

G-5 September 2017
H-5 December 2018
J-5 February 2019
J-7 June 2019
J-8 July 2019
K-5 January 2020
L-5 January 2021

WR72A

H-5 November 2018
J-5 January 2019
J-6 May 2019
J-7 June 2019
J-8 August 2019
K-5 January 2020
L-5 January 2021

WR72A-01

J-6 May 2019
K-5 February 2020

WR72A-D6

H-5 October 2018
J-5 January 2019
J-6 May 2019
J-8 July 2019
K-5 January 2020
L-5 February 2021

SR72A-12

H-5 October 2018
J-5 February 2019
J-6 May 2019
J-8 July 2019
K-5 January 2020
L-5 February 2021

SR72A-16

J-5 January 2019
J-8 July 2019
K-5 January 2020
L-5 March 2021

SR72A-18

H-5 October 2018
H-6 November 2018
J-5 January 2019
J-6 May 2019
J-7 June 2019
J-8 July 2019
K-5 January 2020
L-5 January 2021

SR72A-18M

H-5 October 2018
H-6 November 2018
J-5 January 2019
J-6 May 2019
J-8 July 2019
J-9 September 2019
L-5 January 2021

SR72A-24M

H-5 October 2018
H-6 November 2018
J-5 January 2019
J-6 May 2019
J-9 September 2019
L-5 January 2021

SR72A-30M

H-5 February 2018
H-6 November 2018
J-5 January 2019
J-6 May 2019
J-7 June 2019
J-8 July 2019
J-9 September 2019
K-5 February 2020
L-5 January 2021

SR72A-30MD2

H-5 October 2018
H-6 November 2018
J-5 January 2019
J-7 June 2019
J-9 September 2019
K-5 January 2020
L-5 March 2021

SR72A-30MD4

H-5 October 2018
H-6 November 2018
J-5 January 2019
J-7 June 2019
J-8 August 2019
J-9 September 2019
K-5 February 2020
L-5 February 2021

SR72A-30MD6

H-5 February 2018
H-6 November 2018
J-5 January 2019
J-8 August 2019
J-9 September 2019
K-5 January 2020
L-5 January 2021

Model Codes

The model number code breakdown is as follows:

U – Undercounter

W – Worktop

S– Prep Table

R – Refrigerator

F – Freezer

27, 36, 48, 60, 72 – width

After Dash (-) Nomenclature:

-GLP – Glass Door Low Profile

-01 – Locks

-LP – Low Profile Casters

-LPC – Low Profile Stainless Steel Shelf

-D2, -D4, -D6 – Drawers and Drawer/Door Combination

-8, -10, -12, -16, -18 – Prep Table Number of Pans

-12M, -15M, -18M, -24M, -30M – Mega Top Number of Pans

Auxiliary Code Breakdown

The auxiliary code is the first two characters in the serial number. The first character indicates the year. Years progress or regress in alphabetical order. The series runs from "A" through "V" and the letters "I" and "O" are skipped. The second character indicates significant part changes within a year. Base is "5" and this number advances for each change. In cases where there is a letter in parentheses, this designates the month. This is the last character in the serial number. The series runs from "(A)" through "(M)" and the letter "(I)" is skipped. This designation is only included when identifying a parts change within an auxiliary code.

Note About Ordering Parts

Most assemblies cannot be ordered as complete units; parts in the assemblies generally must be ordered separately.

A. Main Assembly

UR27,WR27,SR27,UF27,andWF27 Undercounter,Worktop,and Prep Table

G-5 to L-5

Undercounter, Worktop, Prep Table Common Parts

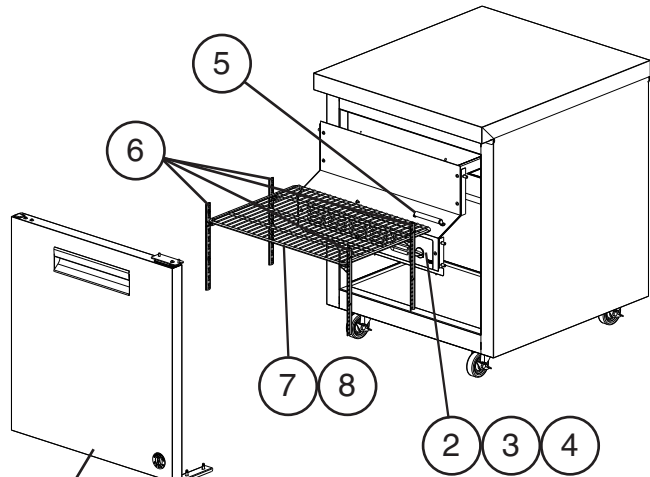

For Door, see Sections "C, D, E or F"

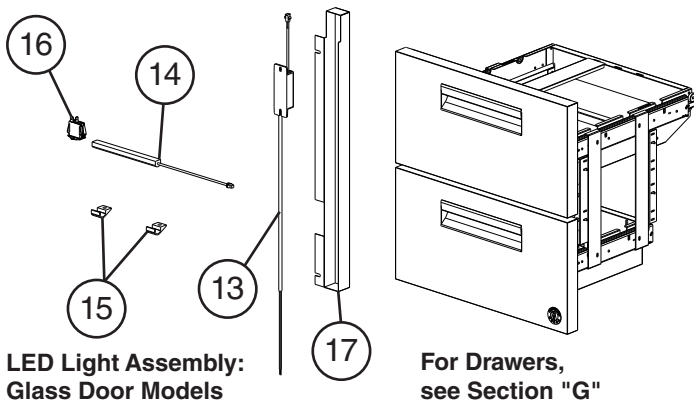
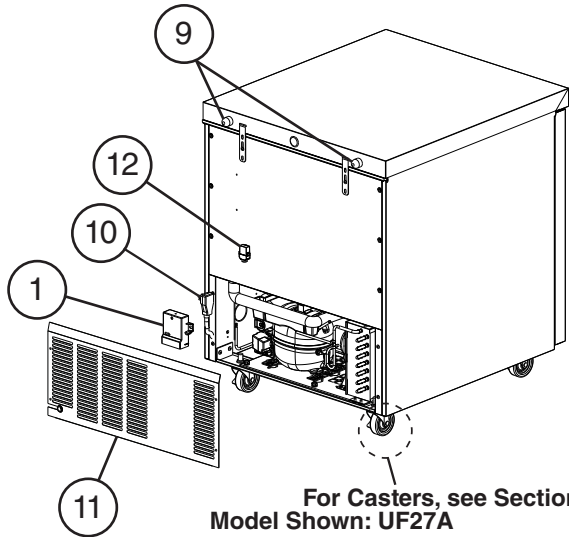

Prep Table Specific Parts

For Pans, see Section "H"

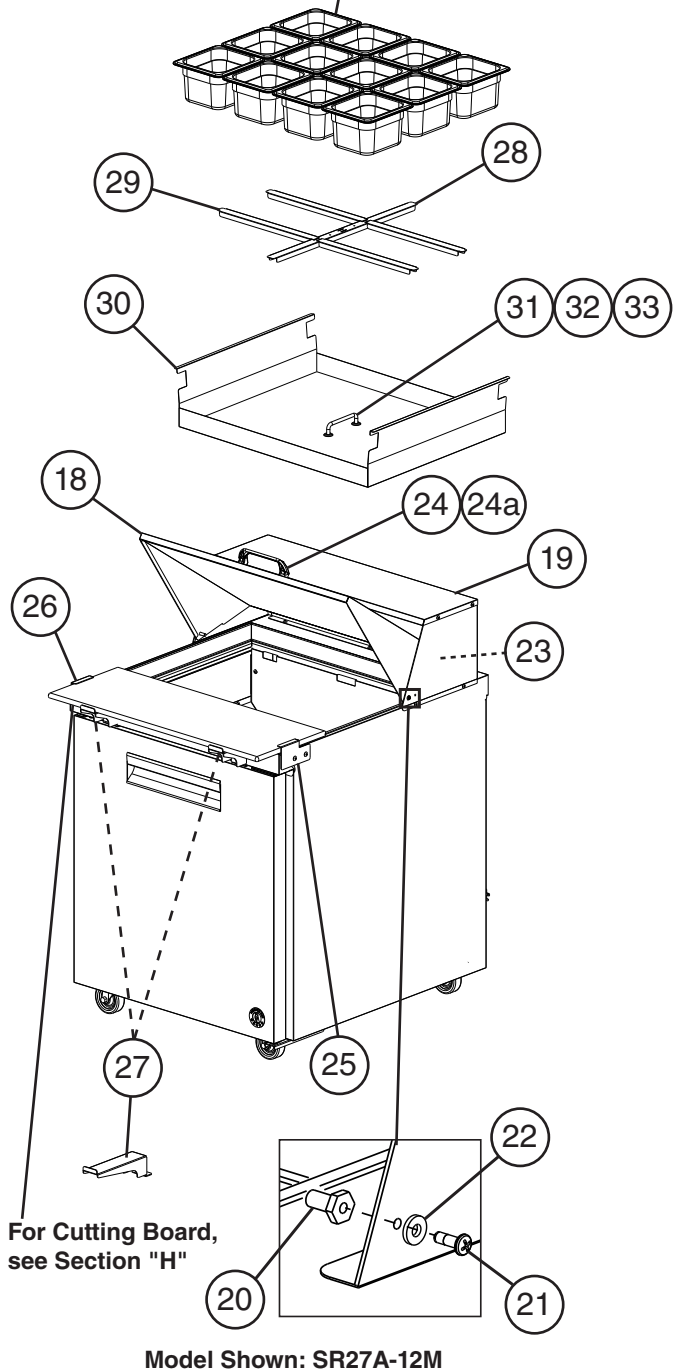

Title: A. Main Assembly Models: UR27, WR27, SR27, UF27, and WF27 Undercounter, Worktop, and Prep Table													
Index No.	Description	Material or Model Number	Part Number	G-5 to L-5	Required Number								
Common Parts													
1	Control Module	UC/WT Refrigerator	4A5959G02	1									
		UC/WT Freezers	4A5959G04	1									
		Prep Tables	4A5959G03	1									
2	Cabinet Temperature Control (Spindle)	UC/WT/ Prep Tables	4A5952-01	1									
3	Dial Plate	UC/WT/ Prep Tables	4A6031-01	1									
4	Dial Knob	UC/WT/ Prep Tables	4A5950-01	1									
5	Cabinet Thermometer		461083-01	1									
6	Side Pilaster	All UC/WT/ Prep Tables Except -D(x) Models	4A5854-01	4									
7	Shelf	All UC/WT/ Prep Tables Except -D(x) Models -LPC Models	3A2830-07	1									
		-LPC Models	3A2830-14	1									
			3A2830-20	1									
8	Shelf Clip	All UC/WT/ Prep Tables Except -D(x) Models	4A5418-01	4									
9	Bumper		3A6696-01	2									
10	Power Cord		4A5718-01	1									
11	Rear Panel	UC/WT Refrigerator and Prep Tables	1A4961-01	1									
		UC/WT Freezers	1A2260-01	1									
12	Pressure Relief Valve	UC/WT Freezers	4A5694-01	1									
13	LED Driver	-GLP01	1A5501-01	1									
14	LED Lamp		3A9348-01	1									
15	LED Clip		4A5906-01	2									
16	LED Switch		4A6067-01	1									
17	Channel			4A6064-01	1								

Title: A. Main Assembly Models: UR27, WR27, SR27, UF27, and WF27 Undercounter, Worktop, and Prep Table

Index No.	Description	Material or Model Number	Part Number	Required Number									
				G-5 to L-5									
Prep Table Specific Parts													
18	Rail Cover (includes items 20 through 24a)	-8, -8D2	3A9410A01	1									
		-12M, -12MD2	3A9411A01	1									
19	Rail Hood		3A9407A01	1									
20	Pivot Pin		4A6161-01	2									
21	Pivot Bolt		4A6160-01	2									
22	Flat Washer		7W22I0832	2									
23	Tree Clip		4A0579-01	2									
24	Handle		1A3416-01	1									
24a	Pan Head Screw		7C12I1412	2									
25	Right Cutting Board Bracket	-8, -8D2, -12M, -12MD2	3A8971-02	1									
26	Left Cutting Board Bracket	-8, -8D2, -12M, -12MD2	3A8971-01	1									
27	Center Cutting Board Bracket	-8, -8D2	4A5905-01	1									
		-12M, -12MD2	4A6794-01	2									
28	Rail Divider (front-to-back)	-8, -8D2 (HS-5187)	3A8903-01	1									
		-12M, -12MD2 (HS-5184)	3A8855-01	1									
29	Rail Divider (side-to-side)	-8, -8D2 (HS-5185)	3B0027-03	2									
		-12M, -12MD2 (HS-5185)		4									
30	Catch Tray (includes items 31 through 33)	-8, -8D	2A8668A01	1									
		-12M, -12MD	2A8666A01	1									
31	Handle		4A4518-01	1									
32	Pan Head Screw	8x32	7C12I0838	2									
33	Flat Washer	-8, -8D2	7W22-0400	2									
		-12M, -12MD2	7W22-0500	2									



A. Main Assembly

UR36, WR36, and SR36 Undercounter, Worktop, and Prep Table

G-5 to L-5

Undercounter, Worktop, Prep Table Common Parts

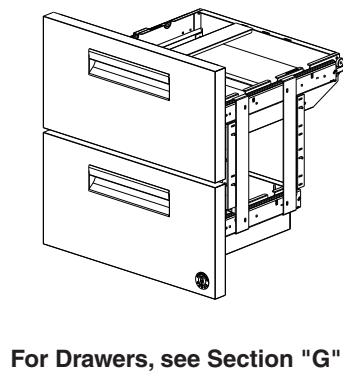
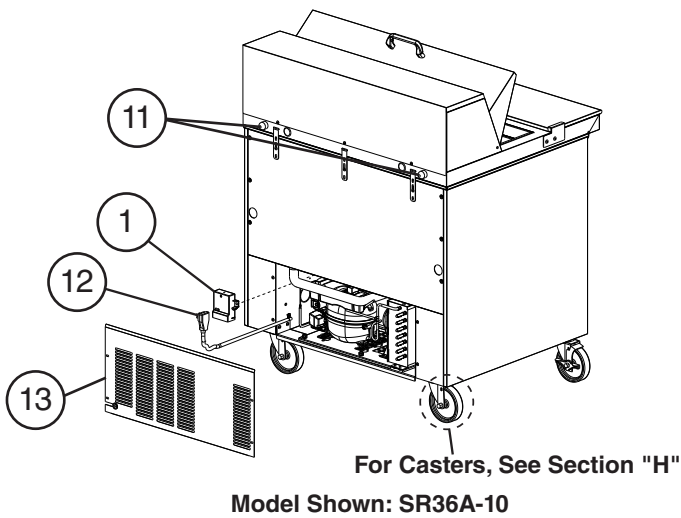
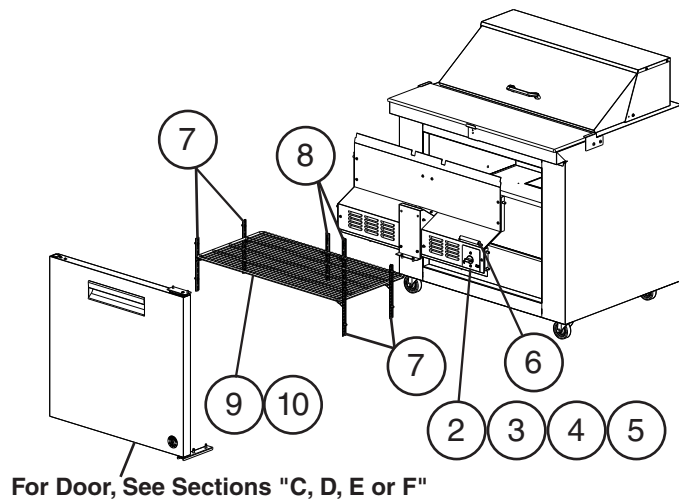

Prep Table Specific Parts

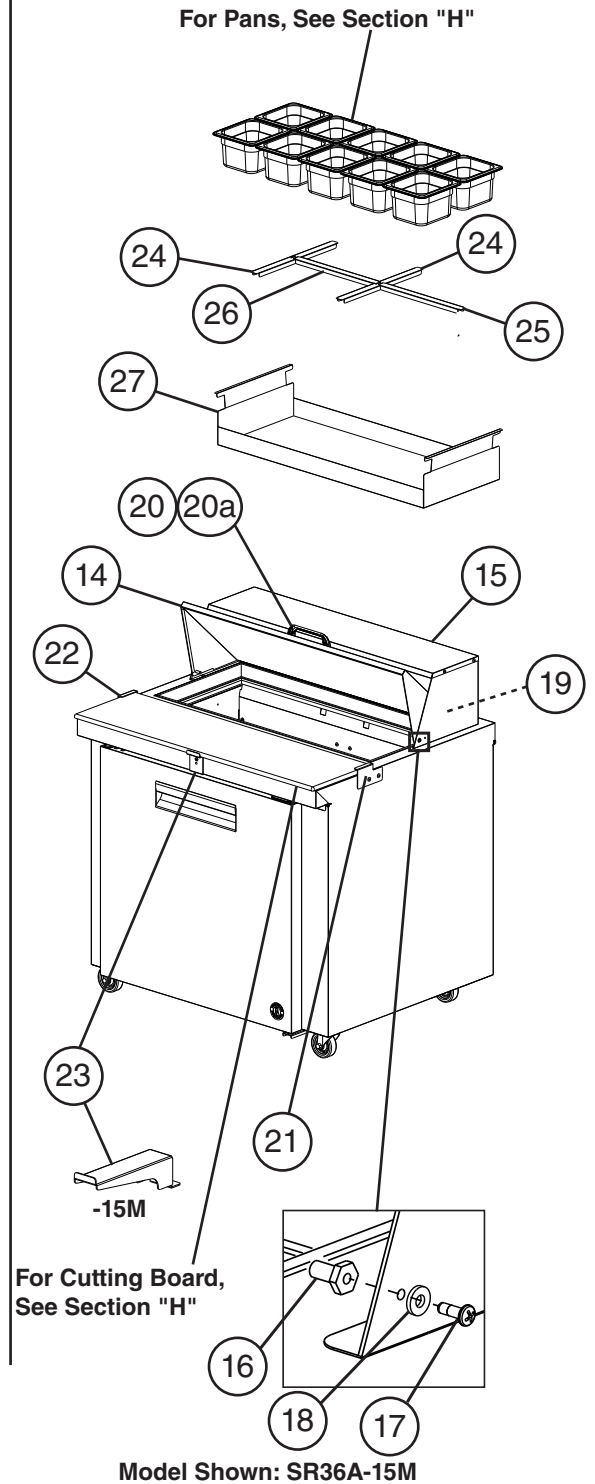

Title: A. Main Assembly Models: UR36, WR36, and SR36 Undercounter, Worktop, and Prep Table												
Index No.	Description	Material or Model Number	Part Number	Required Number								
				G-5 to J-8 (K)	L-5 to L-8							
Common Parts												
1	Control Module	UC/WT	4A5959G02	1	1							
		Prep Table	4A5959G03	1	1							
2	Cabinet Temperature Control (Spindle)		4A5952-01	1	1							
3	Adapter Plate		4A5949-01	1	1							
4	Dial Plate		4A5960-01	1	1							
5	Dial Knob		4A5950-01	1	1							
6	Cabinet Thermometer		461083-01	1	1							
7	Side Pilaster		4A5719-01	4	4							
8	Center Pilaster		4A5417-01	2	2							
9	Shelf		3A6876-05	1	1							
10	Shelf Clip		4A5418-01	6	6							
11	Bumper		3A6696-01	2	2							
12	Power Cord		4A5718-01	1	1							
13	Rear Panel		1A2836-01	1	1							
Prep Table Specific Parts												
14	Rail Cover (includes items 16 through 20a)	-10	3A9408A01	1	1							
		-15M	3A9409A01	1	1							
15	Rail Hood		3A9406A01	1	1							
16	Pivot Pin		4A6161-01	2	2							
17	Pivot Bolt		4A6160-01	2	2							
18	Flat Washer		7W2210832	2	2							
19	Tree Clip		4A0579-01	2	2							
20	Handle		1A3416-01	1	1							
20a	Pan Head Screw		7C1211412	2	2							
21	Right Cutting Board Bracket	-10, -15M	3A8971-02	1	1							
22	Left Cutting Board Bracket	-10, -15M	3A8971-01	1	1							
23	Center Cutting Board Bracket	-10	4A5905-01	1	1							
		-15M	4A6794-01	3	2							
24	Rail Divider (front-to-back)	-10 (HS-5187)	3A8903-01	2	2							
		-15M (HS-5184)	3A8855-01	2	2							
25	Rail Divider (side-to-side outer)	-10 (HS-5185)	3B0027-03	1	1							
		-15M (HS-5185)		2	2							
26	Rail Divider (side-to-side center)	-10 (HS-5186)	3B0028-03	1	1							
		-15M (HS-5186)		2	2							
27	Catch Tray	-10	1A4219-02	1	1							
		-15M	1A4219-03	1	1							

A. Main Assembly

UR48, WR48, SR48, UF48, and WF48 Undercounter, Worktop, and Prep Table

G-5 to L-5

Undercounter, Worktop, Prep Table

Common Parts

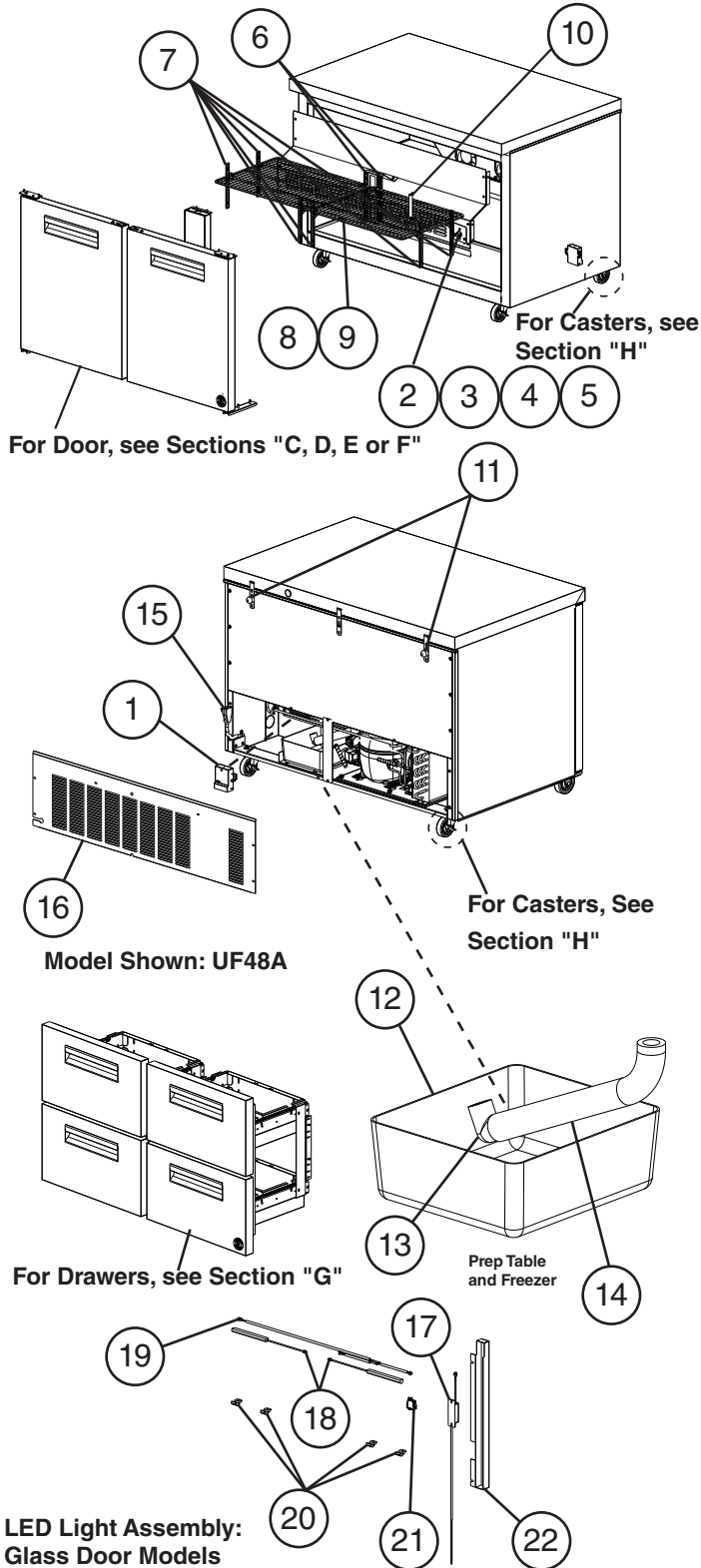

Prep Table Specific Parts

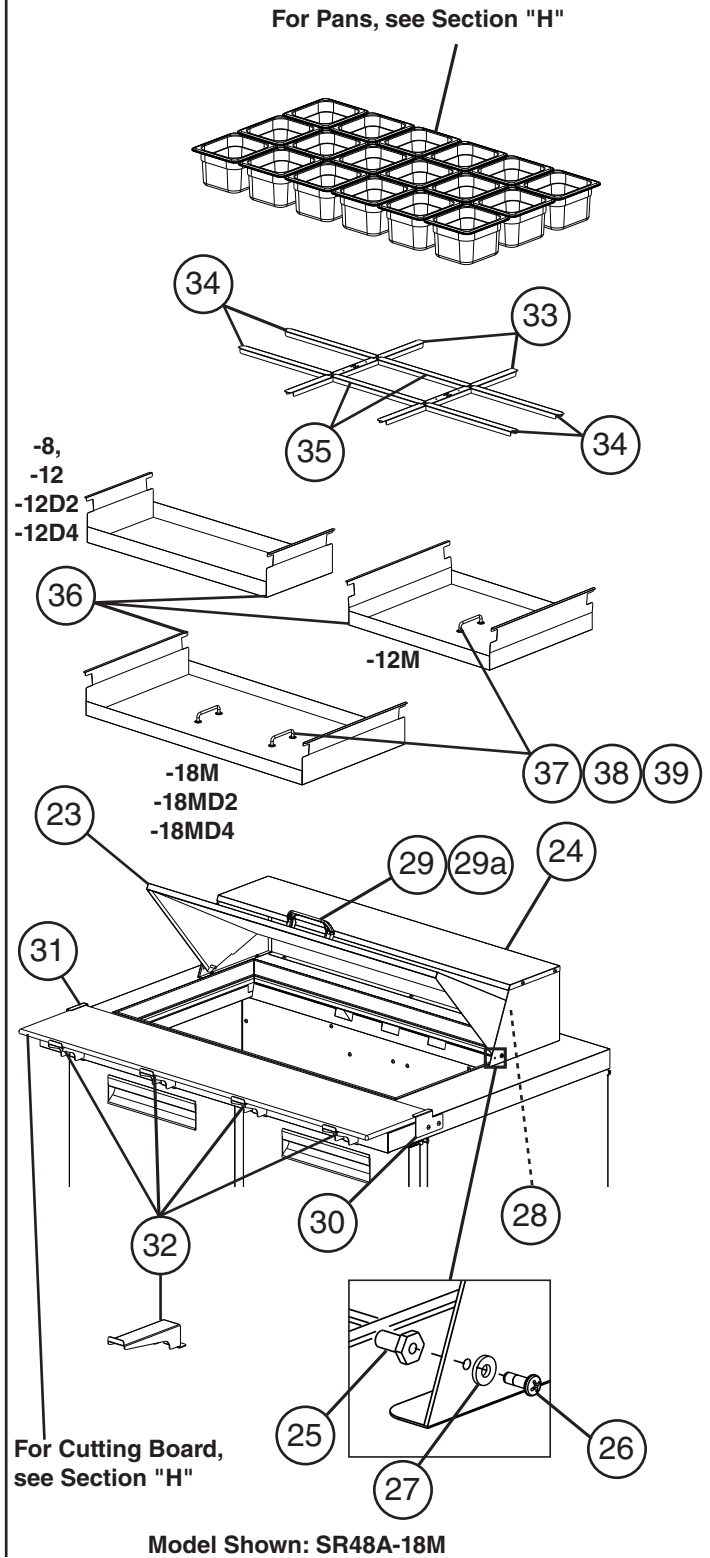

Title: A. Main Assembly Models: UR48, WR48, SR48, UF48, and WF48 Undercounter, Worktop, and Prep Table											
Index No.	Description	Material or Model Number	Part Number	Required Number							
				G-5 to J-8 (K)	J-8 (L) to L-5						
Common Parts											
1	Control Module	UC/WT Refrigerator	4A5959G02	1	1						
		UC/WT Freezers	4A5959G04	1	1						
		Prep Tables	4A5959G03	1	1						
2	Cabinet Temperature Control (Spindle)	UC/WT/Prep Tables	4A5952-01	1	1						
3	Adapter Plate	UC/WT/Prep Tables	4A5949-01	1	1						
4	Dial Plate Label	UC/WT/Prep Tables	4A5960-01	1	1						
5	Dial Knob	UC/WT/Prep Tables	4A5950-01	1	1						
6	Center Back Pilasters	All UC/WT/Prep Tables Except -D(x) Models	4A5417-01	2	2						
7	Sides and Front Pilaster	UC/WT/Prep Tables	4A5719-01	6	6						
		Door/Drawer		4	4						
8	Shelf	UC/WT/Prep Tables	3A2830-08	2	2						
		Door/Drawer		1	1						
9	Shelf Clip	UC/WT/Prep Tables	4A5418-01	8	8						
		Door/Drawer		4	4						
10	Cabinet Thermometer		461083-01	1	1						
11	Bumpers		3A6696-01	2	2						
12	Condensate Pan	UC/WT Freezers/ Prep Tables	1A3373-01	1	1						
13	Elbow Socket		4A5624-01	1	1						
14	Hose		4A0658L01	1	1						
15	Power Cord		4A5718-01	1	1						
16	Rear Panel	UC/WT Refrigerators	1A2261-01	1	1						
		UC/WT Freezers/ Prep Tables	1A5747-01	1	1						
17	LED Driver	-GLP01	1A5501-01	1	1						
18	LED Lamp		3A9348-01	2	2						
19	LED Y Harness		4A6080-01	1	1						
20	LED Clip		4A5906-01	4	4						
21	LED Switch		4A6067-01	1	1						
22	Channel		4A6064-01	1	1						



Title: A. Main Assembly Models: UR48, WR48, SR48, UF48, and WF48 Undercounter, Worktop, and Prep Table										
Index No.	Description	Material or Model Number	Part Number	Required Number						
				G-5 to J-8 (K)	J-8 (L) to L-5					
Prep Table Specific Parts										
23	Rail Cover Assembly (includes items 25 through 29a)	-8	3A9405A01	1	1					
		-12, -12D2, -12D4	3A9398A01	1	1					
		-12M	3A9402A01	1	1					
		-18M, -18MD2, -18MD4	3A9399A01	1	1					
24	Rail Hood	-8	3A9404A01	1	1					
		-12M	3A9403A01	1	1					
		-12, -12D2, -12D4	3A9394A01	1	1					
		-18M, -18MD2, -18MD4	3A9395A01	1	1					
25	Pivot Pin		4A6161-01	2	2					
26	Pivot Bolt		4A6160-01	2	2					
27	Flat Washer		7W22I0832	2	2					
28	Tree Clip		4A0579-01	2	2					
29	Handle		1A3416-01	1	1					
29a	Pan Head Screw		7C12I1412	2	2					
30	Right Cutting Board Bracket		3A8971-02	1	1					
31	Left Cutting Board Bracket		3A8971-01	1	1					
32	Center Cutting Board Bracket	-8, -12, -12D2, -12D4	4A5905-01	2	2					
		-12M, -18M, -18MD2, -18MD4	4A6794-01	4	3					
33	Rail Divider A (front-to-back)	-8 (HS-5188)	3A8904-01	1	1					
		-12, -12D2, -12D4 (HS-5188)		2	2					
		-12M (HS-5184)	3A8855-01	1	1					
		-18M, -18MD2, -18MD4 (HS-5184)		2	2					
34	Rail Divider B (side-to-side)	-8 (HS-5189)	3B0027-01	1	1					
		-12, -12D2, -12D4 (HS-5189)		2	2					
		-12M (HS-5185)	3B0027-03	4	4					
	(outer side-to-side) -18M -18MD2, -18MD4 (HS-5185)	4		4						
35	Rail Divider C (center side-to-side)	-18M, -18MD2, -18MD4 (HS-5186)	3B0028-03	2	2					
36	Catch Tray	-8	1A4221-01	1	1					
		-12, -12D2, -12D4	1A4221-03	1	1					
	(includes items 37 through 39)	-12M	2A8666A01	1	1					
		-18M, -18MD2, -18MD4	2A8667A01	1	1					
37	Handle	12M	4A4518-01	1	1					
		-18M, -18MD2, -18MD4		2	2					
38	Pan Head Screw	-12M	7C12I0838	2	2					
		-18M, -18MD2, -18MD4		4	4					
39	Flat Washer	-8, -8D2	7W22-0400	2	2					
		-12M, -12MD2	7W22-0500	2	2					



A. Main Assembly

UR60, WR60, SR60, UF60, and WF60 Undercounter, Worktop, and Prep Table

G-5 to L-5

Undercounter, Worktop, Prep Table Common Parts

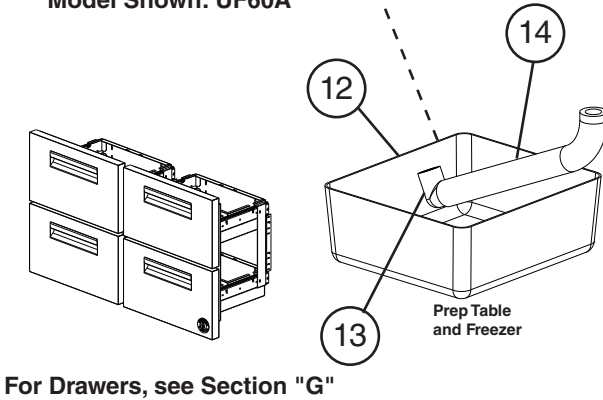
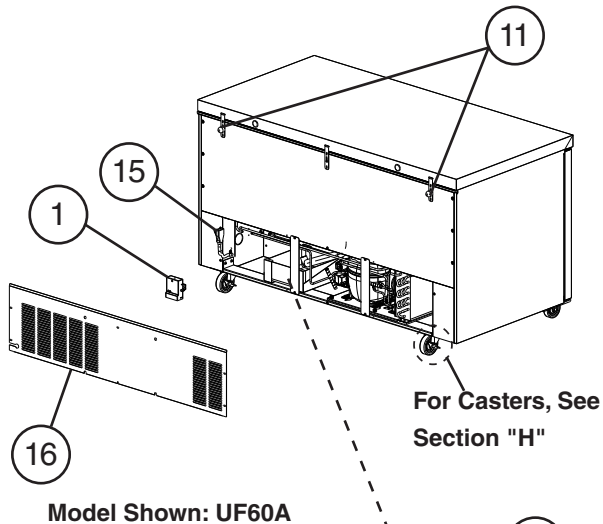
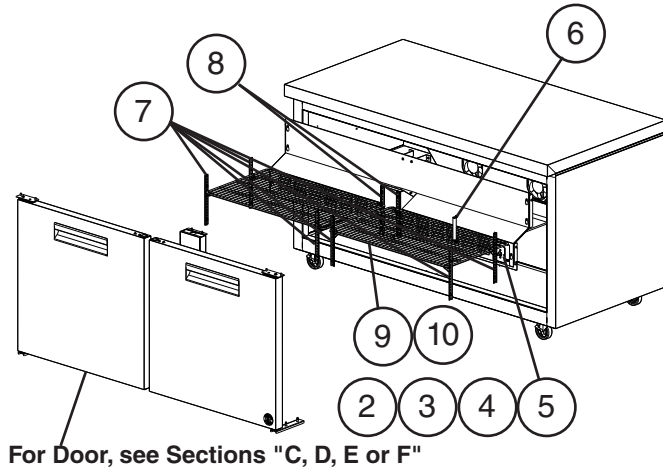

Prep Table Specific Parts

For Pans, see Section "H"

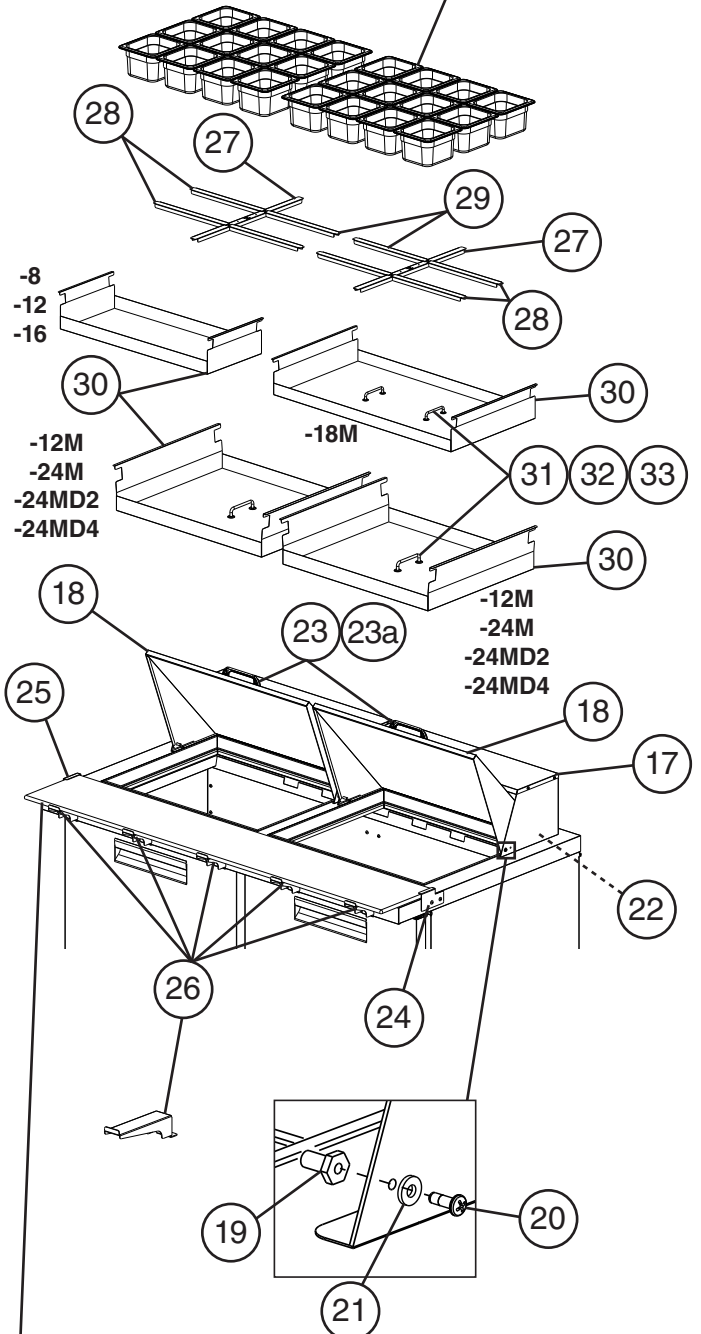

Title: A. Main Assembly Models: UR60, WR60, SR60, UF60, and WF60 Undercounter, Worktop, and Prep Table											
Index No.	Description	Material or Model Number	Part Number	Required Number							
				G-5 to J-9 (K)	J-9 (L) to L-5						
Common Parts											
1	Control Module	UC/WT Refrigerators	4A5959G02	1	1						
		UC/WT Freezers	4A5959G04	1	1						
		Prep Tables	4A5959G03	1	1						
2	Cabinet Temperature Control (Spindle)	UC/WT/Prep Tables	4A5952-01	1	1						
3	Adapter Plate		4A5949-01	1	1						
4	Dial Plate	UC/WT	4A5960-01	1	1						
5	Dial Knob	UC/WT/Prep Tables	4A5950-01	1	1						
6	Cabinet Thermometer		461083-01	1	1						
7	Side and Front Pilaster		4A5719-01	6	6						
		Door/Drawer		4	4						
8	Rear Pilaster		4A5417-01	2	2						
9	Shelf		3A2830-09	2	2						
		Door/Drawer		1	1						
10	Shelf Clip		4A5418-01	8	8						
		Door/Drawer		4	4						
11	Bumpers		3A6696-01	2	2						
12	Condensate Pan	UC/WT Freezers/ Prep Tables	1A3373-01	1	1						
13	Elbow Socket		4A5624-01	1	1						
14	Hose		4A0658L01	1	1						
15	Power Cord		4A5718-01	1	1						
16	Rear Panel	Refrigerators	1A2542-01	1	1						
		UC/WT Freezers/ Prep Tables	1A5751-01	1	1						

Title: A. Main Assembly Models: UR60, WR60, SR60, UF60, and WF60 Undercounter, Worktop, and Prep Table											
Index No.	Description	Material or Model Number	Part Number	Required Number							
				G-5 to J-9 (K)	J-9 (L) to L-5						
Prep Table Specific Parts											
17	Rail Hood	-8	3A9404A01	1	1						
		-12M	3A9403A01	1	1						
		-12	3A9394A01	1	1						
		-18M	3A9395A01	1	1						
		-16	3A9396A01	1	1						
		-24M, -24MD2, -24MD4	3A9403A01	2	2						
18	Rail Cover (includes items 19 through 23a)	-8	3A9405A01	1	1						
		-12	3A9398A01	1	1						
		-12M	3A9402A01	1	1						
		-16	3A9400A01	1	1						
		-18M	3A9399A01	1	1						
		-24M, -24MD2, -24MD4	3A9402A01	2	2						
19	Pivot Pin	-8, -12, -12M, -16, -18M	4A6161-01	2	2						
		-24M, -24MD2, -24MD4		4	4						
20	Pivot Bolt	-8, -12, -12M, -16, -18M	4A6160-01	2	2						
		-24M, -24MD2, -24MD4		4	4						
21	Flat Washer	-8, -12, -12M, -16, -18M	7W22I0832	2	2						
		-24M, -24MD2, -24MD4		4	4						
22	Tree Clip	-8, -12, -12M, -16, -18M	4A0579-01	2	2						
		24M, -24MD2, -24MD4		3	3						
23	Handle	-8, -12, -12M, -16, -18M	1A3416-01	1	1						
		-24M, -24MD2, -24MD4		2	2						
23a	Pan Head Screw	-8, -12, -12M, -16, -18M	7C12I1412	2	2						
		-24M, -24MD2, -24MD4		4	4						
24	Right Cutting Board Bracket	-8, -12, -16, -12M, -18M, -24M, -24MD2, -24MD4	3A8971-02	1	1						
25	Left Cutting Board Bracket	-8, -12, -16, -12M, -18M, -24M, -24MD2, -24MD4	3A8971-01	1	1						
26	Center Cutting Board Bracket	-8, -12, -16	4A5905-01	3	3						
		-12M, -18M, -24M, -24MD2, -24MD4	4A6794-01	5	3						

Title: A. Main Assembly Models: UR60, WR60, SR60, UF60, and WF60 Undercounter, Worktop, and Prep Table											
Index No.	Description	Material or Model Number	Part Number	Required Number							
				G-5 to J-9 (K)	J-9 (L) to L-5						
27	Rail Divider (front-to-back)	-8 (HS-5188)	3A8904-01	1	1						
		-12 (HS-5188)		2	2						
		-16 (HS-5188)		3	3						
		-12M (HS-5184)	3A8855-01	1	1						
		-18M, -24M, -24MD2, -24MD4 (HS-5184)		2	2						
28	Rail Divider (side-to-side)	-8 (HS-5189)	3B0027-01	2	2						
	(outer side-to-side)	-12 (HS-5189)		2	2						
		-16 (HS-5189)		2	2						
	(side-to-side)	-12M (HS-5185)	3B0027-03	4	4						
	(outer side-to-side)	-18M (HS-5185)		4	4						
	(side-to-side)	-24M, -24MD2, -24MD4 (HS-5185)		8	8						
29	Rail Divider C (center side to side)	-12 (HS-5190)	3B0028-01	1	1						
		-16 (HS-5190)		2	2						
		-18M (HS-5186)	3B0028-03	2	2						
30	Catch Tray	-8	1A4221-01	1	1						
		-12	1A4221-03	1	1						
		-16	1A4221-01	2	2						
	(includes items 31 through 33)	-12M, -24M, -24MD2, -24MD4	2A8666A01	2	2						
		-18M	2A8667A01	1	1						
31	Handle		4A4518-01	2	2						
32	Pan Head Screw		7C1210838	4	4						
33	Flat Washer		7W22-0500	4	4						

A. Main Assembly

UR72, WR72, and SR72 Undercounter, Worktop, and Prep Table

G-5 to L-5

Undercounter, Worktop, Prep Table

Common Parts

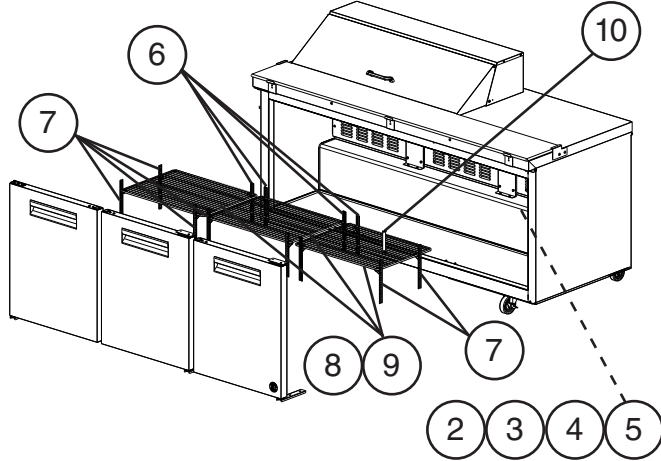

For Door, see Sections "C, D, E or F"

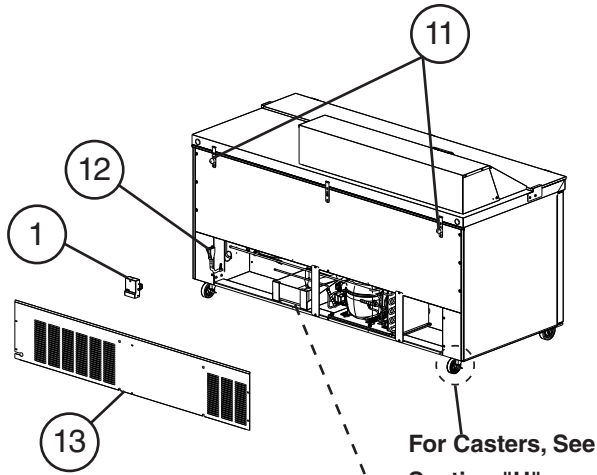

For Casters, See Section "H"

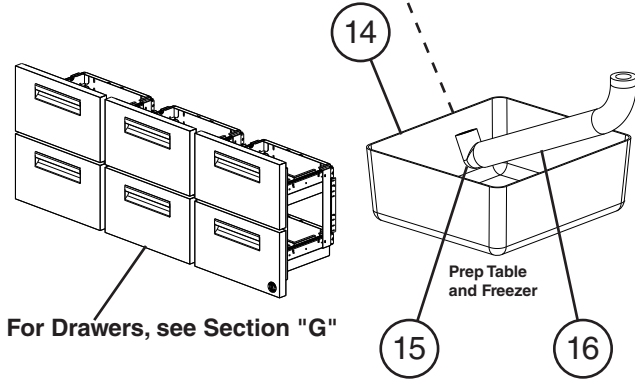

For Drawers, see Section "G"

Condensate Pan for SR72A Series

Prep Table Specific Parts

For Pans, see Section "H"

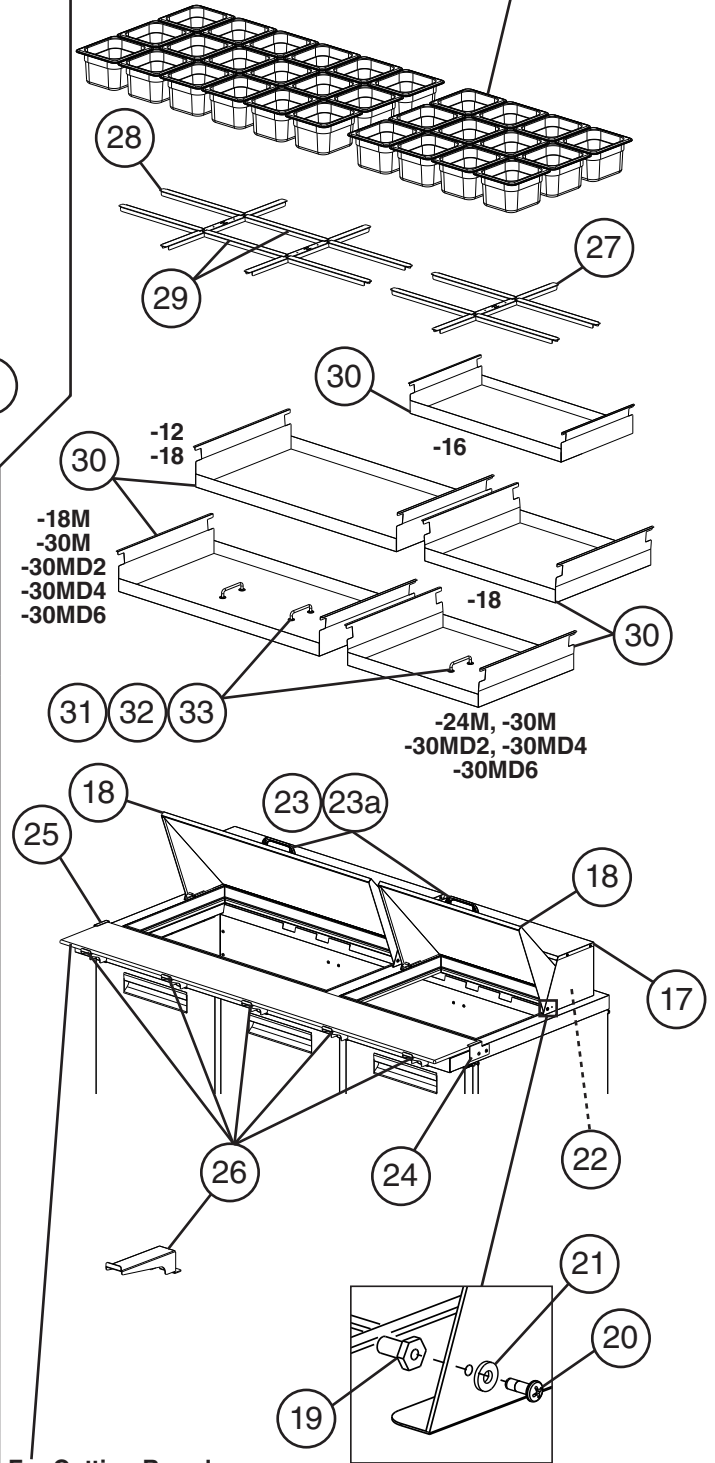

For Cutting Board, see Section "H"

Model Shown: SR72A-30M



Title: A. Main Assembly Models: UR72, WR72, and SR72 Undercounter, Worktop, and Prep Table											
Index No.	Description	Material or Model Number	Part Number	Required Number							
				G-5 to J-9 (K)	J-9 to L-5						
Common Parts											
1	Control Module	UC/WT	4A5959G02	1	1						
		Prep Table	4A5959G03	1	1						
2	Cabinet Temperature Control (Spindle)	UC/WT/Prep Table	4A5952-01	1	1						
3	Adapter Plate	UC/WT/Prep Table	4A5949-01	1	1						
4	Dial Plate		4A5960-01	1	1						
5	Dial Knob	UC/WT/Prep Table	4A5950-01	1	1						
6	Rear Pilaster		4A5417-01	4	4						
		-30MD2		2	2						
7	Side and Front Pilaster		4A5719-01	8	8						
		-30MD2		6	6						
		-30MD4		4	4						
8	Shelf		3A2830-07	3	3						
		-30MD2		2	2						
		-30MD4	3A2830-08	1	1						
9	Shelf Clip		4A5418-01	12	12						
		-30MD2		8	8						
		-30MD4		4	4						
10	Cabinet Thermometer		461083-01	1	1						
11	Bumpers		3A6696-01	2	2						
12	Power Cord		4A5718-01	1	1						
13	Rear Panel	UC/WT	1A2525-01	1	1						
		Prep Tables	1A2668-01	1	1						
14	Condensate Pan	UC/WT	3A9478-01	1	1						
		Prep Table	1A3373-01	1	1						
15	Elbow Socket		4A5624-01	1	1						
16	Hose		4A0658L01	1	1						



Title: A. Main Assembly Models: UR72, WR72, and SR72 Undercounter, Worktop, and Prep Table											
Index No.	Description	Material or Model Number	Part Number	Required Number							
				G-5 to J-9 (K)	J-9 to L-5						
Prep Table Specific Parts											
17	Rail Hood	-12	3A9394A01	1	1						
		-18M	3A9395A01	1	1						
		-16	3A9396A01	1	1						
		-18	3A9397A01	1	1						
		-24M	3A9403A01	2	2						
		-30M, -30MD2, -30MD4, -30MD6 (Right)	3A9403A01	1	1						
		-30M, -30MD2, -30MD4, -30MD6 (Left)	3A9395A01	1	1						
18	Rail Cover (includes items 19 through 23a)	-12	3A9398A01	1	1						
		-16	3A9400A01	1	1						
		-18	3A9401A01	1	1						
		-18M	3A9399A01	1	1						
		-24M	3A9402A01	2	2						
		-30M, -30MD2, -30MD4, -30MD6 (Right)	3A9402A01	1	1						
		-30M, -30MD2, -30MD4, -30MD6 (Left)	3A9399A01	1	1						
19	Pivot Pin	-12, -16, -18, -18M	4A6161-01	2	2						
		-24M, -30M, -30MD2, -30MD4, -30MD6		4	4						
20	Pivot Bolt	-12, -16, -18, -18M	4A6160-01	2	2						
		-24M, -30M, -30MD2, -30MD4, -30MD6		4	4						
21	Flat Washer	-12, -16, -18, -18M	7W22I0832	2	2						
		-24M, -30M, -30MD2, -30MD4, -30MD6		4	4						
22	Tree Clip	-12, -16, -18, -18M	4A0579-01	2	2						
		-24M, -30M, -30MD2, -30MD4, -30MD6		4	4						
23	Handle	-12, -16, -18, -18M	1A3416-01	1	1						
		-24M, -30M, -30MD2, -30MD4, -30MD6		2	2						
23a	Pan Head Screws	-12, -16, -18, -18M	7C12I1412	2	2						
		-24M, -30M, -30MD2, -30MD4, -30MD6		4	4						
24	Right Cutting Board Bracket		3A8971-02	1	1						
25	Left Cutting Board Bracket		3A8971-01	1	1						



Title: A. Main Assembly Models: UR72, WR72, and SR72 Undercounter, Worktop, and Prep Table										
Index No.	Description	Material or Model Number	Part Number	Required Number						
				G-5 to J-9 (K)	J-9 (L) to L-5					
26	Center Cutting Board Bracket	-12, -16, -18	4A5905-01	3	3					
		-18M, -24M, -30M, -30MD2, -30MD4, -30MD6	4A6794-01	5	4					
27	Rail Divider (front-to-back)	-12, -18 (HS-5188)	3A8904-01	2	2					
		-16 (HS-5188)		3	3					
		-18M, -24M (HS-5184)	3A8855-01	2	2					
		-30M, -30MD2, -30MD4, -30MD6 (HS-5184)		3	3					
28	Rail Divider (side-to-side)	-12 (HS-5189)	3B0027-01	2	2					
	(outer side to side)	-16 (HS-5189)		2	2					
		-18 (HS-5191)	3B0027-02	2	2					
	(outer side to side)	-18M (HS-5185)	3B0027-03	4	4					
	(side-to-side)	-24M (HS-5185)		8	8					
	(outer side to side)	-30M, -30MD2, -30MD4, -30MD6 (HS-5185)		8	8					
29	Rail Divider C (center side-to-side)	-12 (HS-5190)	3B0028-01	1	1					
		-16 (HS-5190)		2	2					
		-18 (HS-5192)	3B0028-02	1	1					
		-18M, -30M, -30MD2, -30MD4, -30MD6 (HS-5186)	3B0028-03	2	2					
30	Catch Tray	-12	1A4221-03	1	1					
		-16	1A4221-01	2	2					
		-18	1A4221-02	1	1					
			1A4221-03	1	1					
		-18M	2A8667A01	1	1					
		-24M	2A8666A01	2	2					
		-30M, -30MD2, -30MD4, -30MD6	2A8666A01	1	1					
2A8667A01	1		1							
31	Handle	2A8666A01	4A4518-01	1	1					
		2A8667A01		2	2					
32	Pan Head Screw	2A8666A01	7C12I0838	2	2					
		2A8667A01		4	4					
33	Flat Washer	2A8666A01	7W22-0500	2	2					
		2A8667A01		4	4					

B. Refrigeration Circuit

UR27, WR27, and SR27 Undercounter, Worktop, and Prep Table

G-5 to L-5

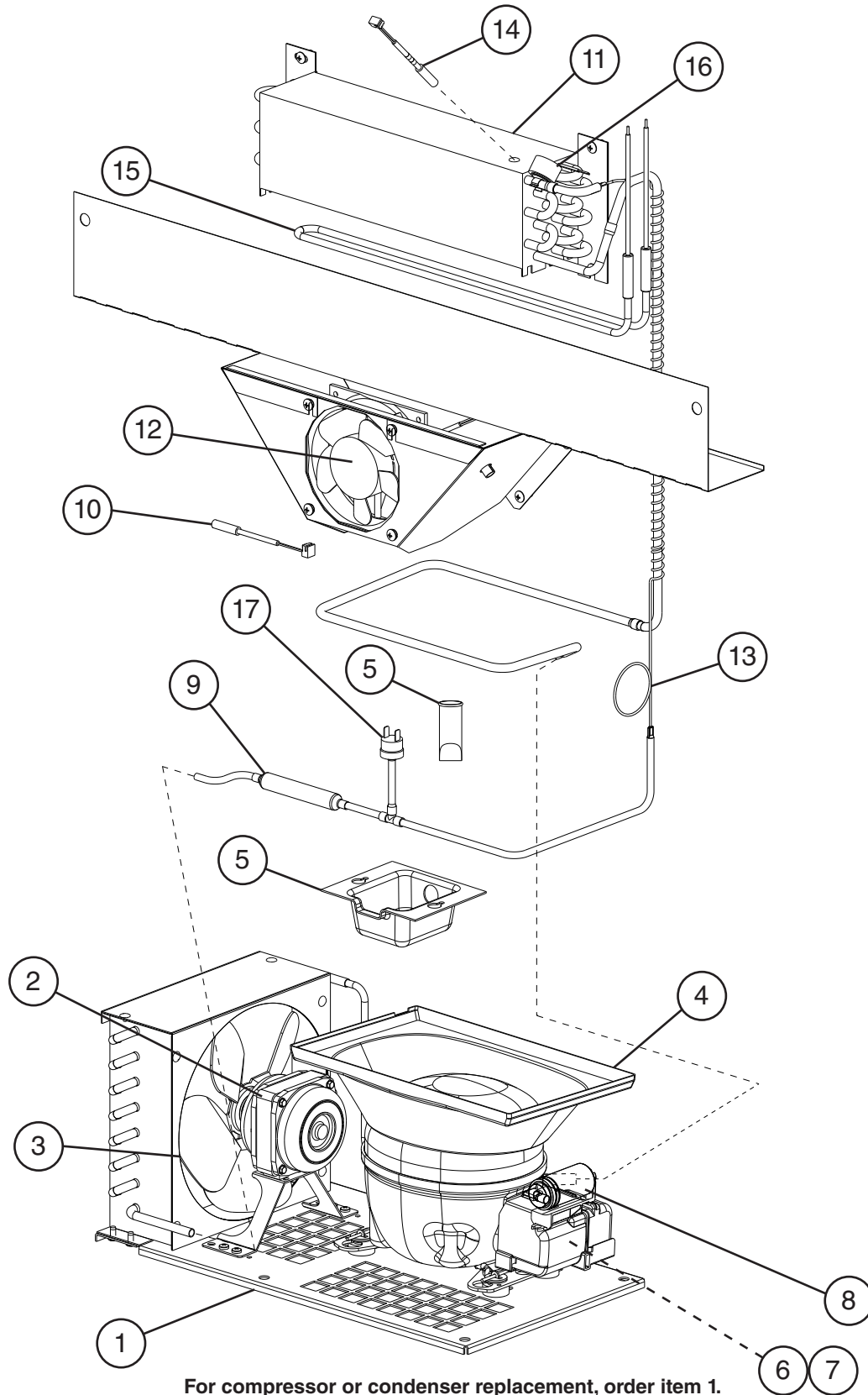

Title: B. Refrigeration Circuit Models: UR27, WR27, and SR27 Undercounter, Worktop, Prep Table										
Index No.	Description	Material or Model Number	Part Number	Required Number						
				G-5 to H-5	H-6 to L-5					
1	Condensing Unit (includes compressor, condenser, and items 2 through 8; compressor and condenser are not sold individually)	UC/WT	3A9520-01	1	1					
		Prep Table	3A9316-01	1	1					
2	Condenser Fan Motor		3A6798-01	1	1					
3	Condenser Fan Blade		3A6799-01	1	1					
4	Condensate Pan	UC/WT	3A6758-01	1	1					
		Prep Table	3A9478-01	1	1					
5	Drain Cup	UC/WT	3A9702-01	1	1					
	Duct Bill	Prep Tables	SP-5345	1	-					
	Drain Cup		3A9702-01		1					
6	Compressor External Protector	UC/WT	3A9522-01	1	1					
		Prep Table	3A9475-01	1	1					
7	Start Relay	UC/WT	3A9523-01	1	1					
		Prep Table	3A9476-01	1	1					
8	Start Capacitor	UC/WT 145-175MFD, 250VAC	3A9524-01	1	1					
	Run Capacitor	Prep Table 12MFD, 250VAC	3A9477-01	1	1					
9	Drier		4A5576-01	1	1					
10	Cabinet Thermistor	UC/WT/Prep Tables	4A4864-01	1	1					
11	Evaporator		2A8513-01	1	1					
12	Evaporator Fan Motor		4A5343-01	1	1					
13	Capillary Tube Replacement Kit	L=2438mm	SP-5437	1	1					
14	Defrost Thermistor	Prep Table	4A4865-01	1	1					
15	Defrost Heater	Prep Table	3A6443-05	1	1					
16	Defrost Safety Thermostat	Prep Table	4A5853-01	1	1					
17	High-Pressure Switch		4A6039-01	1	1					

B. Refrigeration Circuit
UF27 and WF27 Undercounter and Worktop
 G-5 to L-5

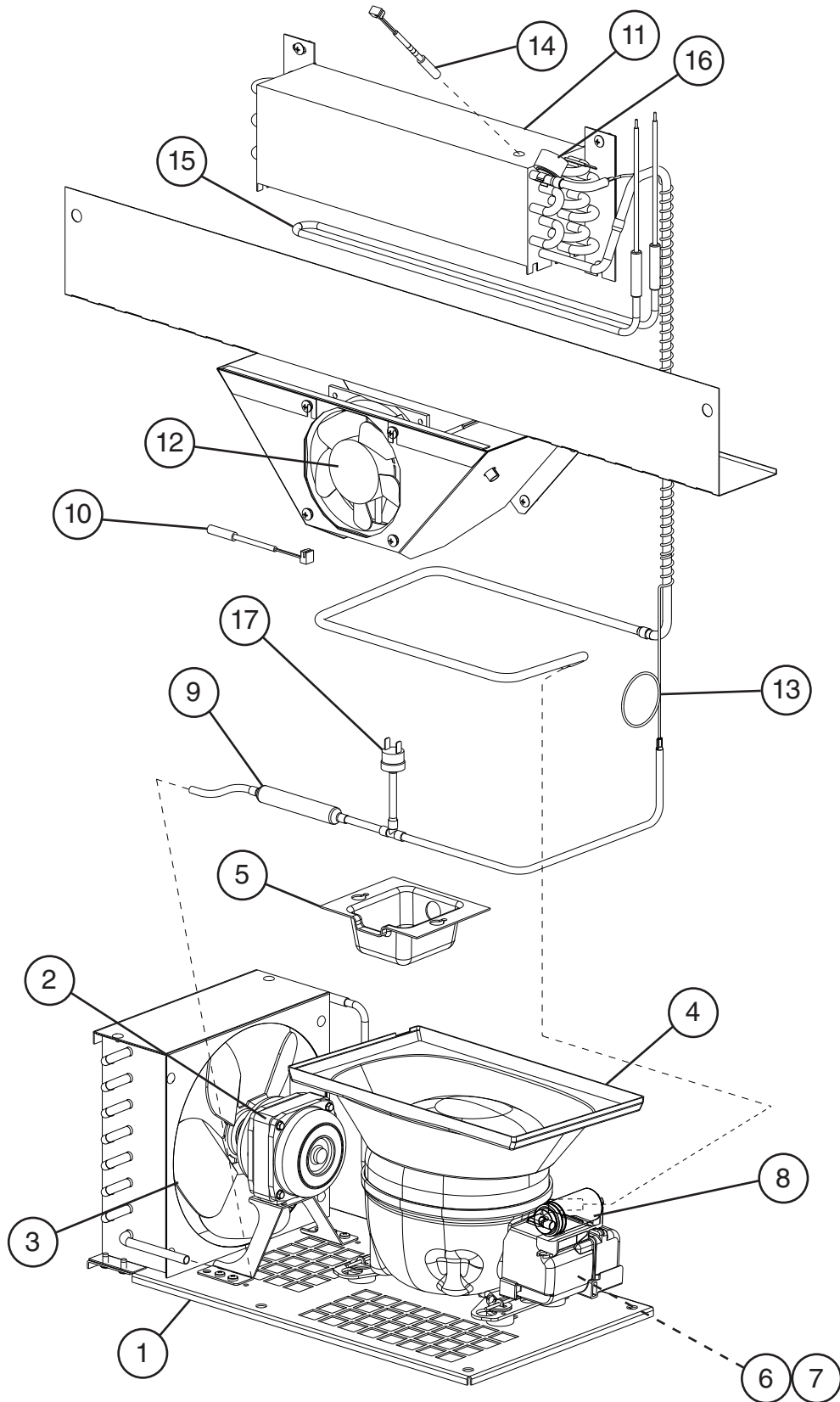

For compressor or condenser replacement, order item 1.

Title: B. Refrigeration Circuit Models: UF27 and WF27 Undercounter and Worktop											
Index No.	Description	Material or Model Number	Part Number	G-5 to L-5	Required Number						
1	Condensing Unit (includes compressor, condenser, and items 2 through 7; compressor and condenser are not sold individually)		3A9316-01	1							
2	Condenser Fan Motor		3A6798-01	1							
3	Condenser Fan Blade		3A6799-01	1							
4	Condensate Pan		3A9478-01	1							
5	Drain Cup		3A9702-01	1							
6	Compressor External Protector		3A9475-01	1							
7	Start Relay		3A9476-01	1							
8	Run Capacitor	UC/WT 12MFD, 250VAC	3A9477-01								
9	Drier		4A5576-01	1							
10	Cabinet Thermistor		4A4864-01	1							
11	Evaporator		2A8513-01	1							
12	Evaporator Fan Motor		4A5343-01	1							
13	Capillary Tube Replacement Kit	L=1499mm	SP-5436	1							
14	Defrost Thermistor		4A4865-01	1							
15	Defrost Heater		3A6443-05	1							
16	Defrost Safety Thermostat		4A0954-02	1							
17	High-Pressure Switch		4A6039-01	1							



Title: B. Refrigeration Circuit Models: UR36, WR36, SR36 Undercounter, Worktop, Prep Table												
Index No.	Description	Material or Model Number	Part Number	Required Number								
				G-5 to L-5								
1	Condensing Unit (includes compressor, condenser, and items 2 through 8; compressor and condenser are not sold individually)	UC/WT/Prep Table	3A9520-01	1								
2	Condenser Fan Motor		3A6798-01	1								
3	Condenser Fan Blade		3A6799-01	1								
4	Condensate Pan		3A6758-01	1								
5	Drain Cup		3A9702-01	1								
6	Compressor External Protector		3A9522-01	1								
7	Start Relay		3A9523-01	1								
8	Start Capacitor	145-175MFD, 250VAC	3A9524-01	1								
9	Drier		4A5576-01	1								
10	Cabinet Thermistor		4A4864-01	1								
11	Evaporator		2A8513-01	1								
12	Evaporator Fan Motor		4A5343-01	1								
13	Capillary Tube (includes: capillary tube, drier, cover, insulation)	L=2438mm	SP-5438	1								
14	Defrost Thermistor	Prep Table	4A4865-01	1								
15	Defrost Heater	Prep Table	3A6443-05	1								
16	Defrost Safety Thermostat (thermodisc)	Prep Table	4A5853-01	1								
17	High-Pressure Switch		4A6039-01	1								



B. Refrigeration Circuit

UR48, WR48, and SR48 Undercounter, Worktop, and Prep Table

G-5 to L-5

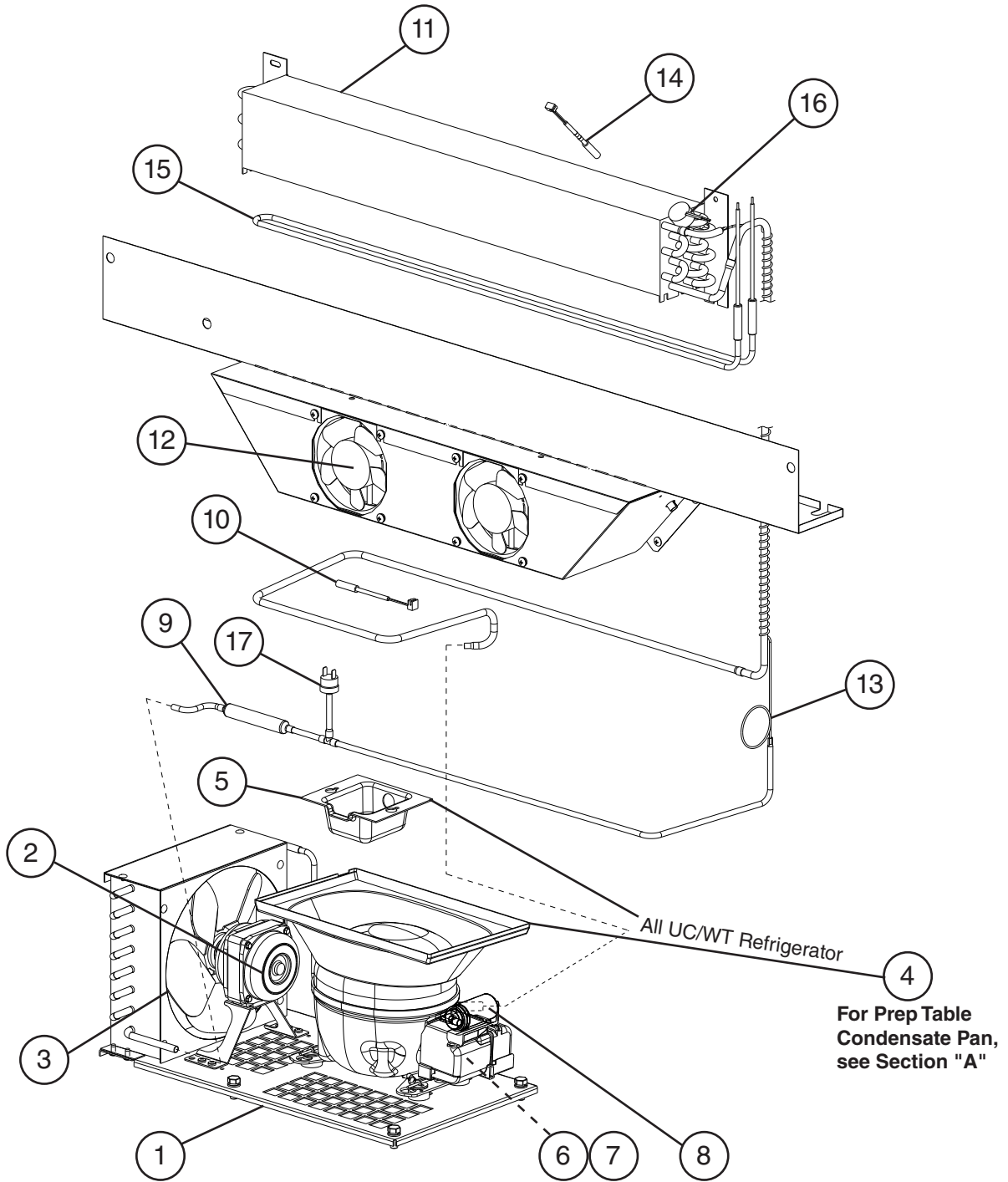

Title: B. Refrigeration Circuit Models: UR48, WR48, and SR48 Undercounter, Worktop, and Prep Table												
Index No.	Description	Material or Model Number	Part Number	G-5 to L-5	Required Number							
1	Condensing Unit (includes compressor, condenser, and items 2 through 8; compressor and condenser are not sold individually)	UC/WT	3A9520-01	1								
		Prep Table	3A9316-01	1								
2	Condenser Fan Motor		3A6798-01	1								
3	Condenser Fan Blade		3A6799-01	1								
4	Condensate Pan	UC/WT	3A6758-01	1								
5	Drain Cup	Refrigerators	3A9702-01	1								
6	Compressor External Protector	UC/WT	3A9522-01	1								
		Prep Table	3A9475-01	1								
7	Start Relay	UC/WT	3A9523-01	1								
		Prep Table	3A9476-01	1								
8	Start Capacitor	UC/WT 145-175MFD, 250VAC	3A9524-01	1								
	Run Capacitor	Prep Table 12MFD, 250VAC	3A9477-01	1								
9	Drier		4A5576-01	1								
10	Cabinet Thermistor		4A4864-01	1								
11	Evaporator		2A8513-02	1								
12	Evaporator Fan Motor		4A5343-01	2								
13	Capillary Tube Replacement Kit	UC/WT L=2684mm	SP-5437	1								
		Prep Table L=3584mm	SP-5438	1								
14	Defrost Thermistor	Prep Table	4A4865-01	1								
15	Defrost Heater	Prep Table	3A6443-04	1								
16	Defrost Safety Thermostat	Prep Table	4A5853-01	1								
17	High-Pressure Switch		4A6039-01	1								

B. Refrigeration Circuit
UF48 and WF48 Undercounter and Worktop
 G-5 to L-5

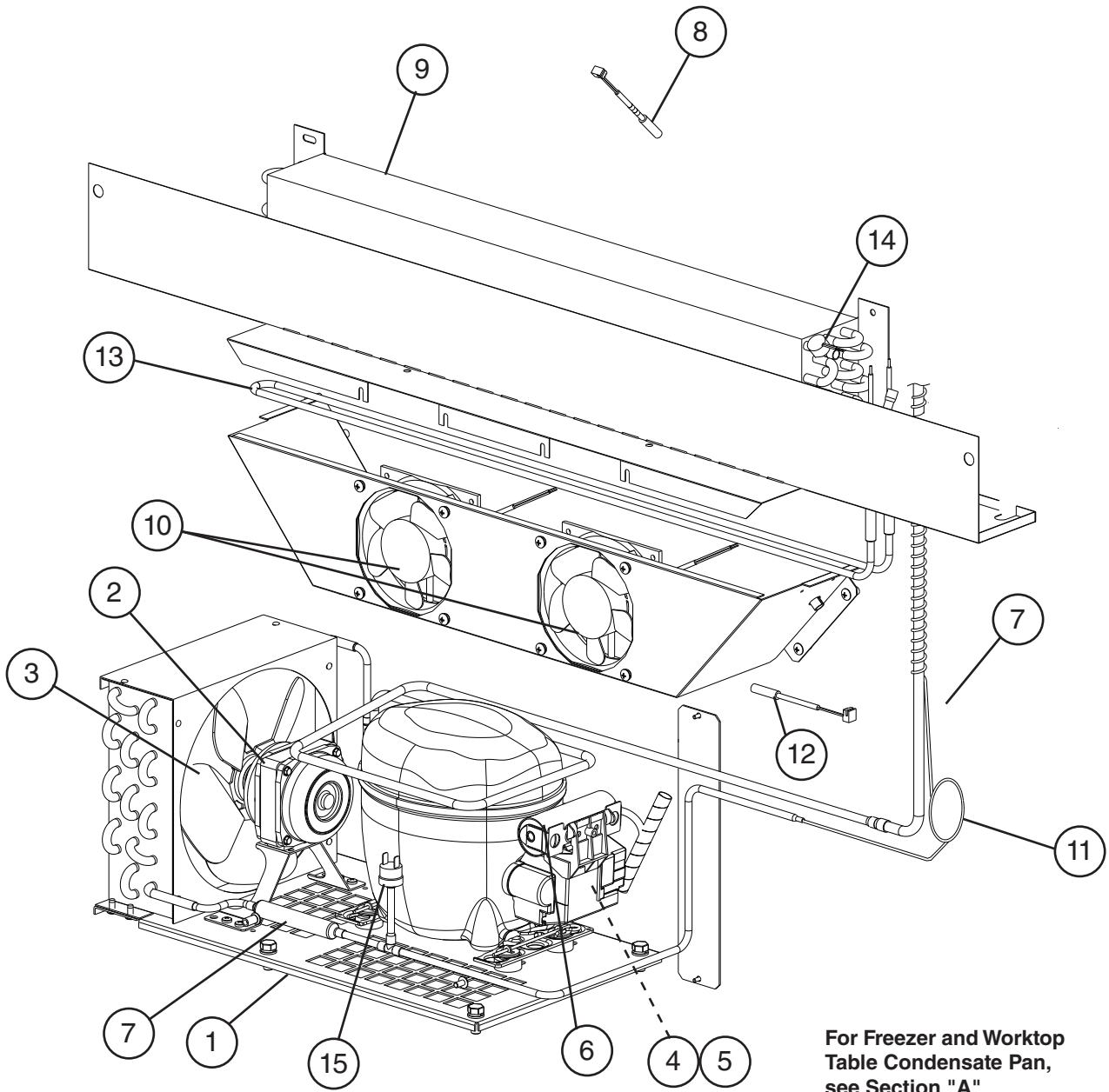

For Freezer and Worktop
 Table Condensate Pan,
 see Section "A"

For compressor or condenser replacement, order item 1.



Title: B. Refrigeration Circuit Models: UF48 and WF48 Undercounter and Worktop												
Index No.	Description	Material or Model Number	Part Number	G-5 to L-5	Required Number							
1	Condensing Unit (includes compressor, condenser, and items 2 through 6; compressor and condenser are not sold individually)		3A9313-01	1								
2	Condenser Fan Motor		3A6798-01	1								
3	Condenser Fan Blade		3A6799-01	1								
4	Compressor External Protector		3A6936-01	1								
5	Start Relay		3A6937-01	1								
6	Start Capacitor	378-454MFD, 115VAC	3A6938-01	1								
7	Drier		4A5576-01	1								
8	Cabinet Thermistor		4A4864-01	1								
9	Evaporator		2A8513-02	1								
10	Evaporator Fan Motor		4A5343-01	2								
11	Capillary Tube Replacement Kit	L=1829mm	SP-5435	1								
12	Defrost Thermistor		4A4865-01	1								
13	Defrost Heater		3A6443-04	1								
14	Defrost Safety Thermostat		4A5853-01	1								
15	High-Pressure Switch		4A6039-01	1								



Title: B. Refrigeration Circuit Models: UR60, WR60, and SR60 Undercounter, Worktop, and Prep Table											
Index No.	Description	Material or Model Number	Part Number	Required Number							
				G-5 to H-5 (K)	H-5 (L) to L-5						
1	Condensing Unit (includes compressor, condenser, and items 2 through 8; compressor and condenser are not sold individually)	UC/WT	3A9316-01	1	1						
		Prep Table	3A9313-01	1	1						
2	Condenser Fan Motor		3A6798-01	1	1						
3	Condenser Fan Blade		3A6799-01	1	1						
4	Condensate Pan	UC/WT	3A9478-01	1	1						
5	Duct Bill	UC/WT	SP-5345	1	-						
	Drain Cup		3A9702-01		1						
6	Compressor External Protector	UC/WT	3A9475-01	1	1						
		Prep Table	3A6936-01	1	1						
7	Start Relay	UC/WT	3A9476-01	1	1						
		Prep Table	3A6937-01	1	1						
8	Run Capacitor	UC/WT 12MFD, 250VAC	3A9477-01	1	1						
	Start Capacitor	Prep Table 378-454MFD, 115VAC	3A6938-01	1	1						
9	Drier		4A5576-01	1	1						
10	Cabinet Thermistor	UC/WT/Prep Table	4A4864-02	1	1						
11	Evaporator		2A8513-03	1	1						
12	Evaporator Fan Motor		4A5343-01	2	2						
13	Capillary Tube Replacement Kit	UC/WT/Prep Table L=2184mm	SP-5434	1	1						
14	Defrost Thermistor	Prep Table	4A4865-02	1	1						
15	Defrost Heater	Prep Table	3A6443-06	1	1						
16	Defrost Thermostat	Prep Table	4A5853-01	1	1						
17	High-Pressure Switch	Prep Table	4A6039-01	1	1						

B. Refrigeration Circuit
UF60 and WF60 Undercounter and Worktop
G-5 to L-5

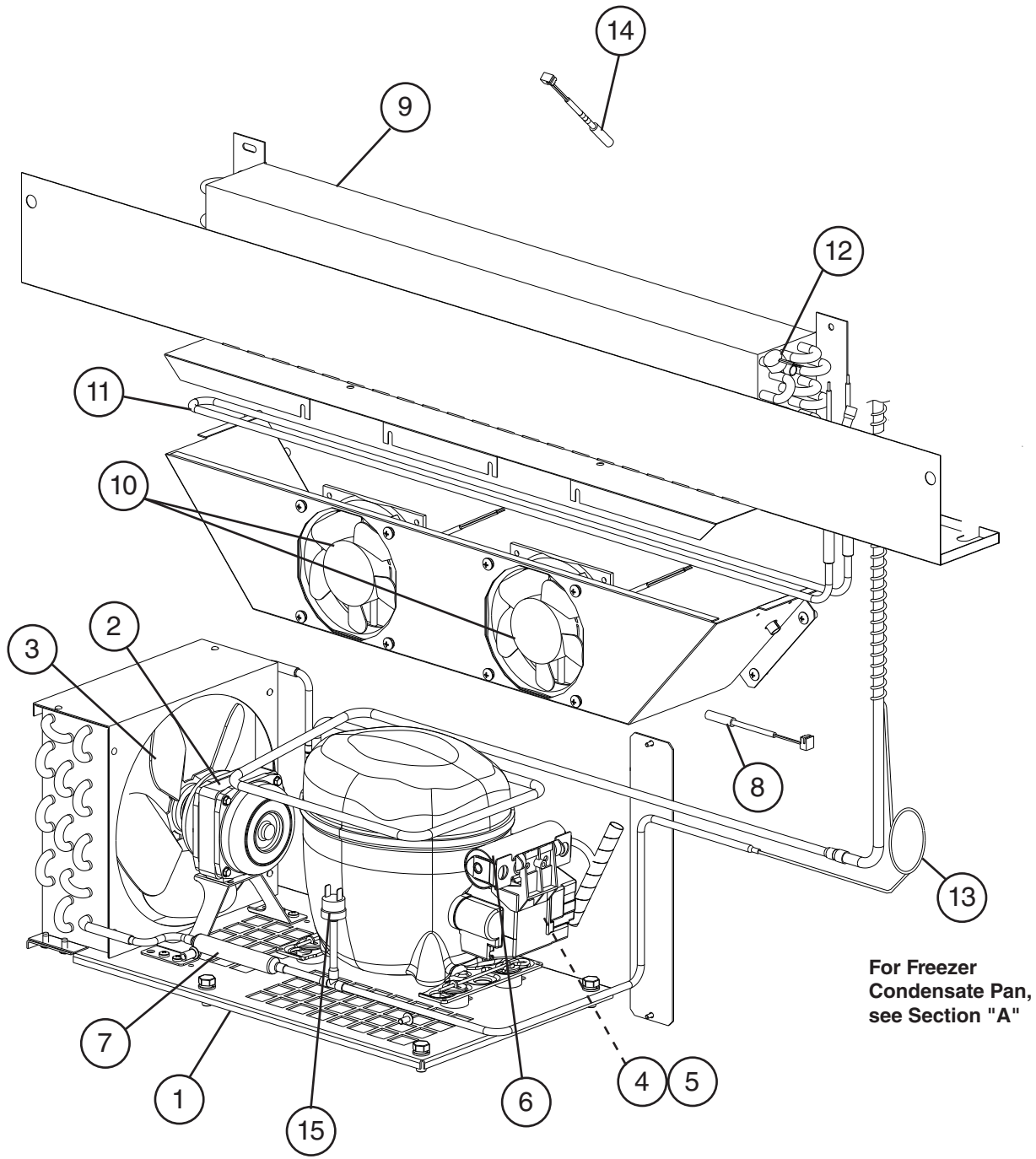

For compressor or condenser replacement, order item 1.



Title: B. Refrigeration Circuit Models: UF60 and WF60 Undercounter and Worktop											
Index No.	Description	Material or Model Number	Part Number	G-5 to L-5	Required Number						
1	Condensing Unit (includes compressor, condenser, and items 2 through 6; compressor and condenser are not sold individually)		3A9313-01	1							
2	Condenser Fan Motor		3A6798-01	1							
3	Condenser Fan Blade		3A6799-01	1							
4	Compressor External Protector		3A6936-01	1							
5	Start Relay		3A6937-01	1							
6	Start Capacitor	378-454MFD, 115VAC	3A6938-01	1							
7	Drier		4A5576-01	1							
8	Cabinet Thermistor		4A4864-02	1							
9	Evaporator		2A8513-03	1							
10	Evaporator Fan Motor		4A5343-01	2							
11	Defrost Heater		3A6443-06	1							
12	Defrost Thermostat		4A5853-01	1							
13	Capillary Tube Replacement Kit	L=1829mm	SP-5435	1							
14	Defrost Thermistor		4A4865-02	1							
15	High-Pressure Switch		4A6039-01	1							



B. Refrigeration Circuit

UR72, WR72, and SR72 Undercounter, Worktop, Prep Table

G-5 to L-5

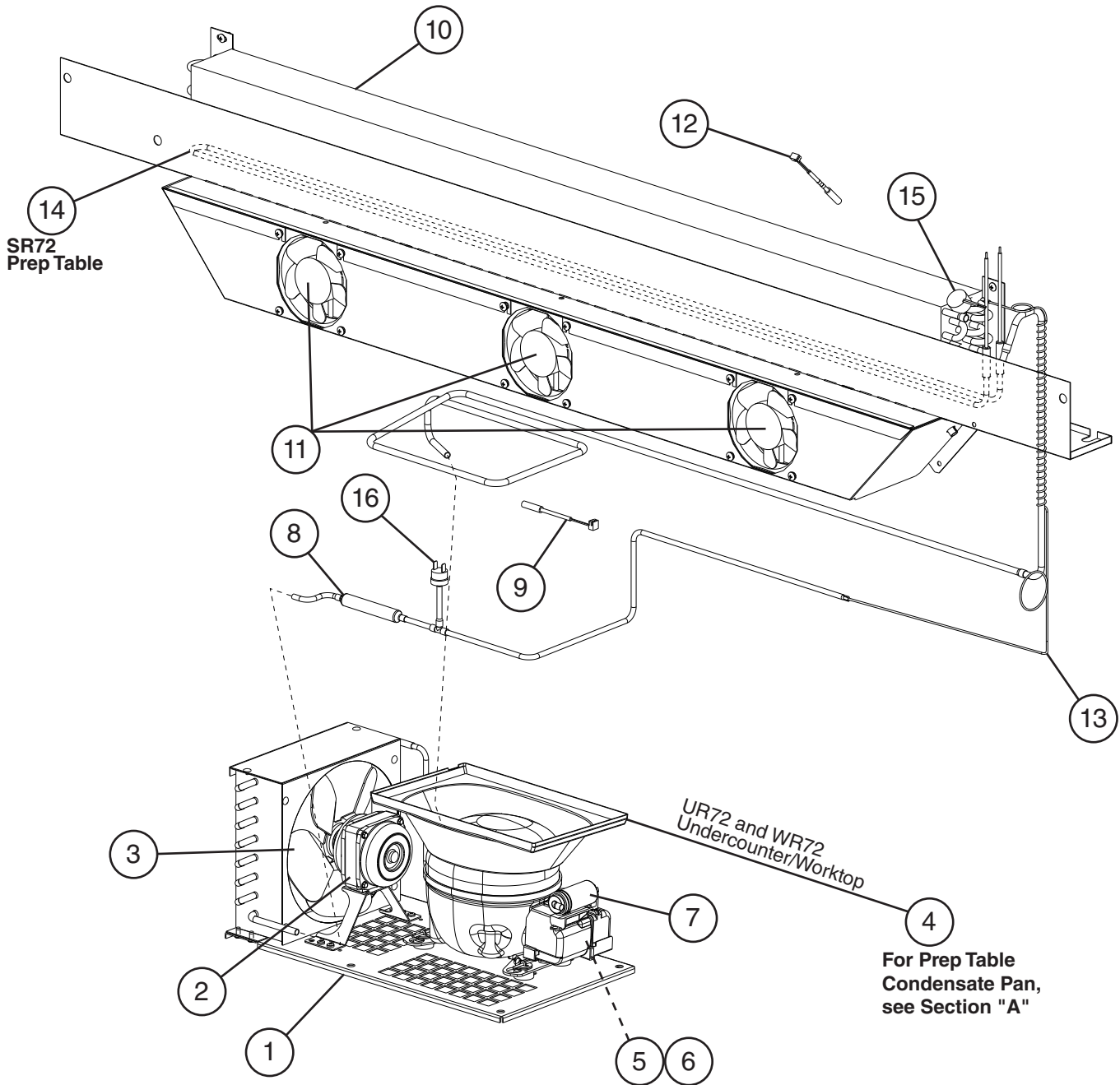

For compressor or condenser replacement, order item 1.

Title: B. Refrigeration Circuit Models: UR72, WR72, and SR72 Undercounter, Worktop, and Prep Table												
Index No.	Description	Material or Model Number	Part Number	Required Number								
				G-5 to L-5								
1	Condensing Unit (includes compressor, condenser, and items 2 through 7; compressor and condenser are not sold individually)	UC/WT	3A9316-01	1								
		Prep Table	3A9313-01	1								
2	Condenser Fan Motor		3A6798-01	1								
3	Condenser Fan Blade		3A6799-01	1								
4	Condensate Pan	UC/WT	3A9478-01	1								
5	Compressor External Protector	UC/WT	3A9475-01	1								
		Prep Table	3A6936-01	1								
6	Start Relay	UC/WT	3A9476-01	1								
		Prep Table	3A6937-01	1								
7	Run Capacitor	UC/WT 12MFD, 250VAC	3A9477-01	1								
	Start Capacitor	Prep Table 378-454MFD, 115VAC	3A6938-01	1								
8	Drier		4A5576-01	1								
9	Cabinet Thermistor	UC/WT/Prep Table	4A4864-02	1								
10	Evaporator		2A8513-04	1								
11	Evaporator Fan Motor		4A5343-01	3								
12	Capillary Tube Replacement Kit	UC/WT L=3584mm	SP-5437	1								
		Prep Table L=2184mm	SP-5434	1								
13	Defrost Thermister	Prep Table	4A4865-02	1								
14	Defrost Heater	Prep Table	3A6443-07	1								
15	Defrost Safety Thermostat	Prep Table	4A5853-01	1								
16	High-Pressure Switch	Prep Table	4A6039-01	1								

C. Door-Right Hinged
Undercounter, Worktop, Prep Table
 G-5 to L-5

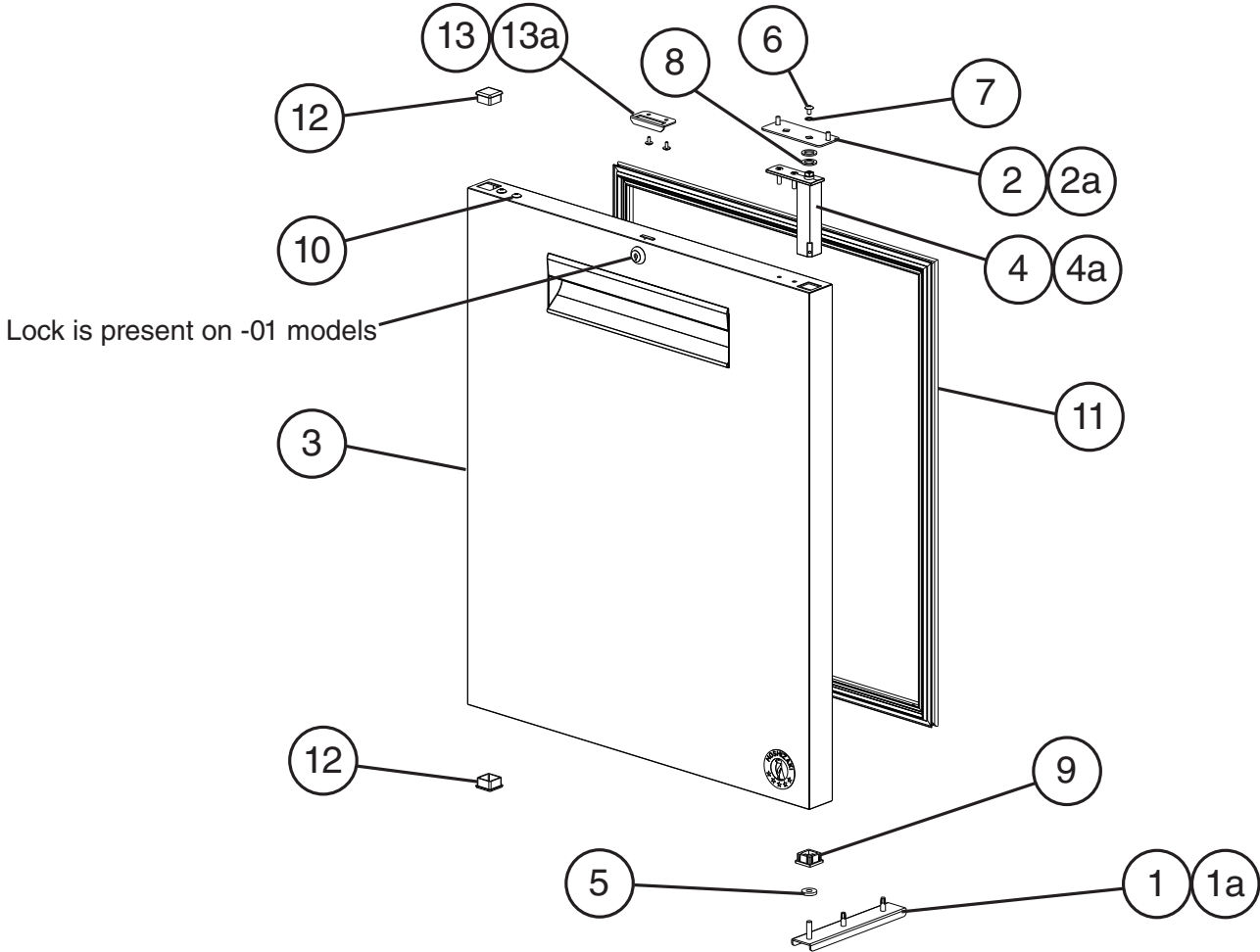

Title: C. Door-Right Hinged Models: Undercounter, Worktop, Prep Table											
Index No.	Description	Material or Model Number	Part Number	G-5 to L-5	Required Number						
1	Lower Hinge Bracket		3A6681G01	1							
1a	Hex Head Tapping Bolt	1/4-20x3/4	4A5213-01	2							
2	Upper Hinge Bracket		3A6810-01	1							
2a	Truss Head Screw	5x12, SS	7C32-0512	2							
3	Door Assembly without Locks (includes items 4 through 12)	_R27A and _F27A, (All except -01, -LPW, and -GLP)	2A7322G01	1							
		UR27A-LPW	2A8635G01	1							
		_R36A, _R60A and _F60A UC/WT/Prep Table (All except -01)	2A7328G01	1							
		_R48A, _F48A, and _R72A UC/WT/Prep Table (All except -01)	2A7324G01	1							
	Door Assembly with Locks (includes items 4 through 12)	_R27A-01 and _F27A-01	2A7323G01	1							
		_R36A-01, _R60A-01, and _F60A-01	2A8291G01	1							
_R48A-01, _F48A-01 and _R72A-01		2A7327G01	1								
4	Hinge Spring Cartridge (includes items 5 through 9)		3A9206-01	1							
4a	Countersunk Screw	5x20, SS	7C42-0520	2							
5	Thrust Washer		4A5234-01	1							
6	Screw		4A5230-01	1							
7	Lockwasher		4A5231-01	1							
8	Thrust Washer		4A5233-01	2							
9	Bearing		4A5232-01	1							
10	Truss Head Screw (filler screws)	5x10, SS	7C32-0510	2							
11	Gasket	_R27A and _F27A, UC/WT/Prep Table	2A6996-05	1							
		_R36A, _R60A, and _F60A UC/WT/Prep Table	2A6996-09	1							
		_R48A, _F48A, and _R72A UC/WT/Prep Table	2A6996-06	1							
12	End Cap		4A5432-01	2							
13	Strike Plate for Doors with Locks	-01 UC/WT	4A5493-01	1							
13a	T2 Screw	-01 UC/WT 4x8, SS	7P32-0408	2							

D. Door-Left Hinged Undercounter, Worktop, Prep Table G-5 to L-5

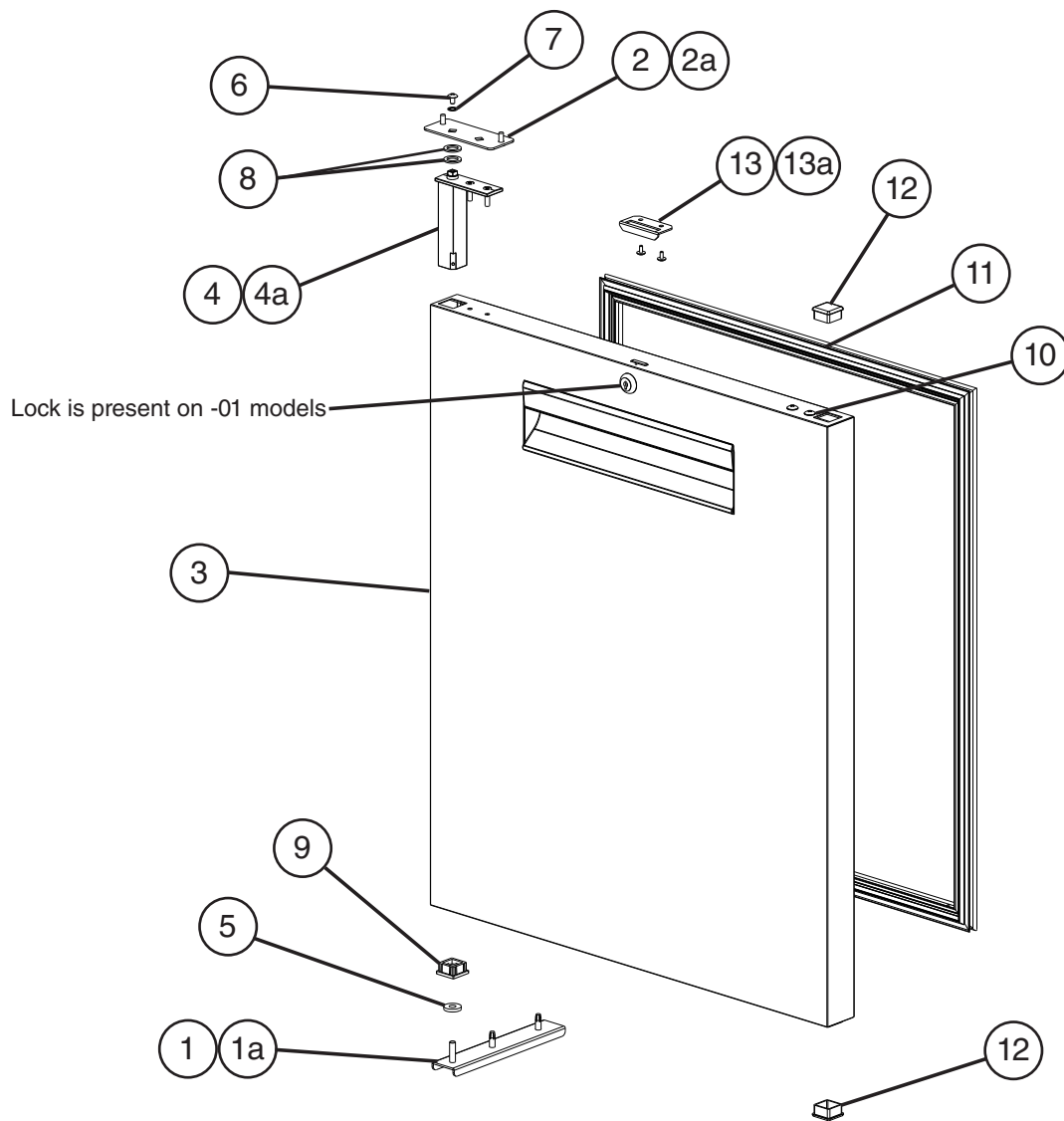

Title: D. Door-Left Hinged Models: Undercounter, Worktop, Prep Table												
Index No.	Description	Material or Model Number	Part Number	G-5 to L-5	Required Number							
1	Lower Hinge Bracket		3A6681G01	1								
1a	Hex Head Tapping Bolt	1/4-20x3/4	4A5213-01	2								
2	Upper Hinge Bracket		3A6810-01	1								
2a	Truss Head Screw	5x12, SS	7C32-0512	2								
3	Door Assembly without Locks (includes items 4 through 12)	_R48A, _F48A, and _R72A UC/WT/Prep Table (All except -01)	2A7325G01	1								
		_R60 and _F60A UC/WT/Prep Table (All except -01)	2A7329G01	1								
	Door Assembly with Locks (includes items 4 through 12)	_R60A-01 and _F60A-01	2A8293G01	1								
		_R48A-01, _F48A-01, and _R72A-01	2A7326G01	1								
4	Hinge Spring Cartridge (includes items 5 through 9)		3A9206-01	1								
4a	Countersunk Screw	5x20, SS	7C42-0520	2								
5	Thrust Washer		4A5234-01	1								
6	Screw		4A5230-01	1								
7	Lockwasher		4A5231-01	1								
8	Thrust Washer		4A5233-01	2								
9	Bearing		4A5232-01	1								
10	Truss Head Screw (filler screws)	5x10, SS	7C32-0510	2								
11	Gasket	_R48A, _F48A, and _R72A UC/WT/Prep Table	2A6996-06	1								
		_F60A UC/WT/Prep Table	2A6996-09	1								
12	End Cap		4A5432-01	2								
13	Strike Plate for Doors with Locks	-01 UC/WT	4A5493-01	1								
13a	T2 Screw	-01 UC/WT 4x8, SS	7P32-0408	2								

E. Door-Right Glass Door Hinged Undercounter, Worktop, Prep Table G-5 to L-5

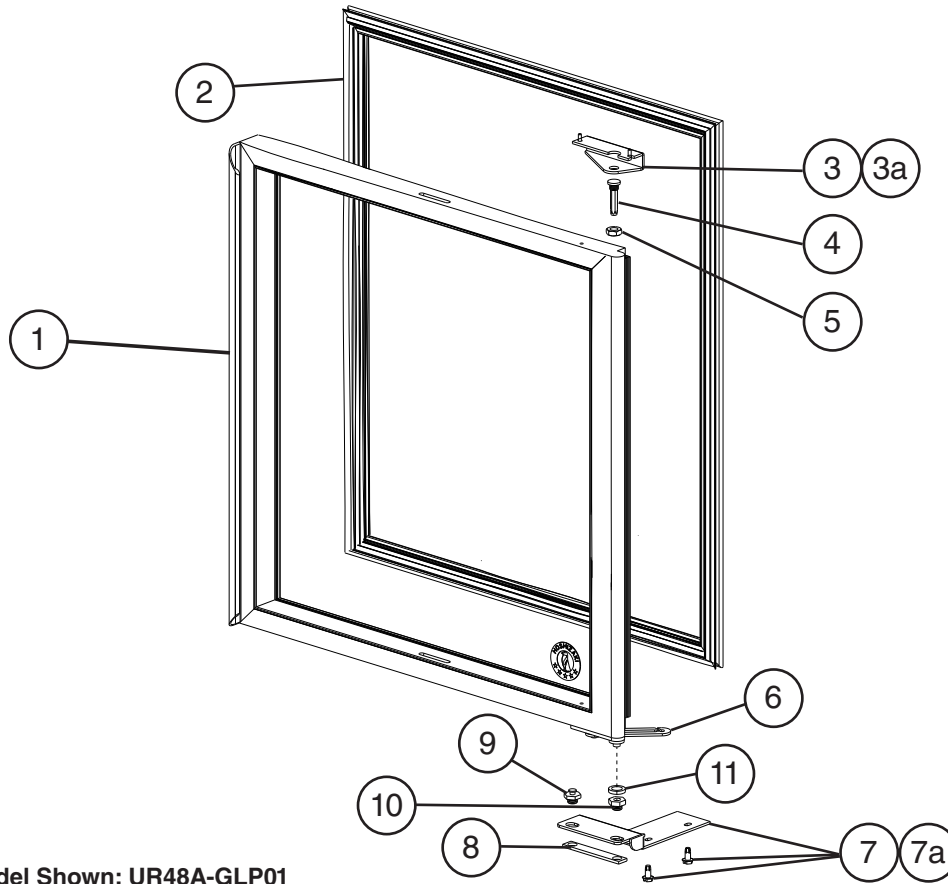

Model Shown: UR48A-GLP01

Title: E. Door-Right Glass Door Hinged Models: Undercounter, Worktop, Prep Table					Required Number								
Index No.	Description	Material or Model Number	Part Number	G-5 to L-5									
1	Door (includes gasket and hinge arm)	UR27A-GLP01	2A8853-03	1									
		UF27A-GLP01	2A8853-04	1									
		UR48A-GLP01 Right Side Hinged Door	2A8852-03	1									
2	Gasket	U_27A-GLP01	4A6448-01	1									
		UR48A-GLP01	4A6449-01	1									
3	Upper Hinge		3A9346-02	1									
3a	Truss Head Screw	5x12, SS	7C32-0512	2									
4	Hinge Pin		3A7946-04	1									
5	Hinge Pin Locknut		3A7946-05	1									
6	Hinge Arm		3A7946-01	1									
7	Lower Hinge		3A9342-01	1									
7a	Hex Head Tapping Bolt	1/4-20x3/4	4A5213-01	2									
8	Backer Plate		3A7946-08	1									
9	Slide Pin		3A7946-11	1									
10	Hinge Bushing		3A7946-09	1									
11	Nylon Washer		3A7946-10	1									

F. Door-Left Glass Door Hinged Undercounter, Worktop, Prep Table

G-5 to L-5

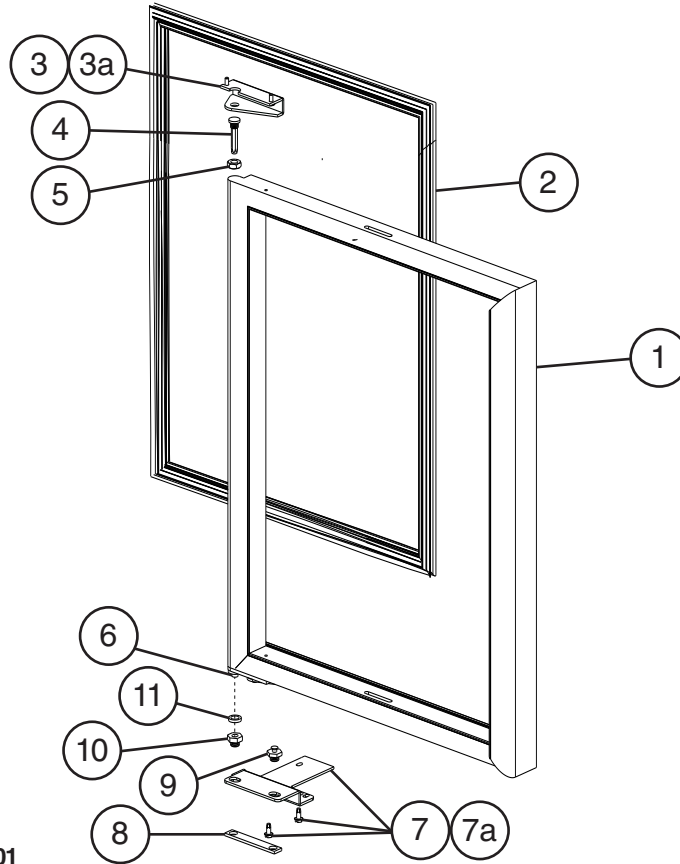

Model Shown: UR48A-GLP01

Title: F. Door-Left Glass Door Hinged Models: Undercounter, Worktop, Prep Table					Required Number							
Index No.	Description	Material or Model Number	Part Number	G-5 to L-5								
1	Door (includes gasket and hinge arm)	UR48A-GLP01	2A8852-01	1								
2	Gasket	UR48A-GLP01	4A6449-01	1								
3	Upper Hinge		3A9346-01	1								
3a	Truss Head Screw	5x12, SS	7C32-0512	2								
4	Hinge Pin		3A7946-04	1								
5	Hinge Pin Locknut		3A7946-05	1								
6	Hinge Arm		3A7946-01	1								
7	Lower Hinge		3A9342-02	1								
7a	Hex Head Tapping Bolt	1/4-20x3/4	4A5213-01	2								
8	Backer Plate		3A7946-08	1								
9	Slide Pin		3A7946-11	1								
10	Hinge Bushing		3A7946-09	1								
11	Nylon Washer		3A7946-10	1								

G. Drawer
Undercounter, Worktop, Prep Table (-D)(-D2)(-D4)(-D6)
G-5 to L-5

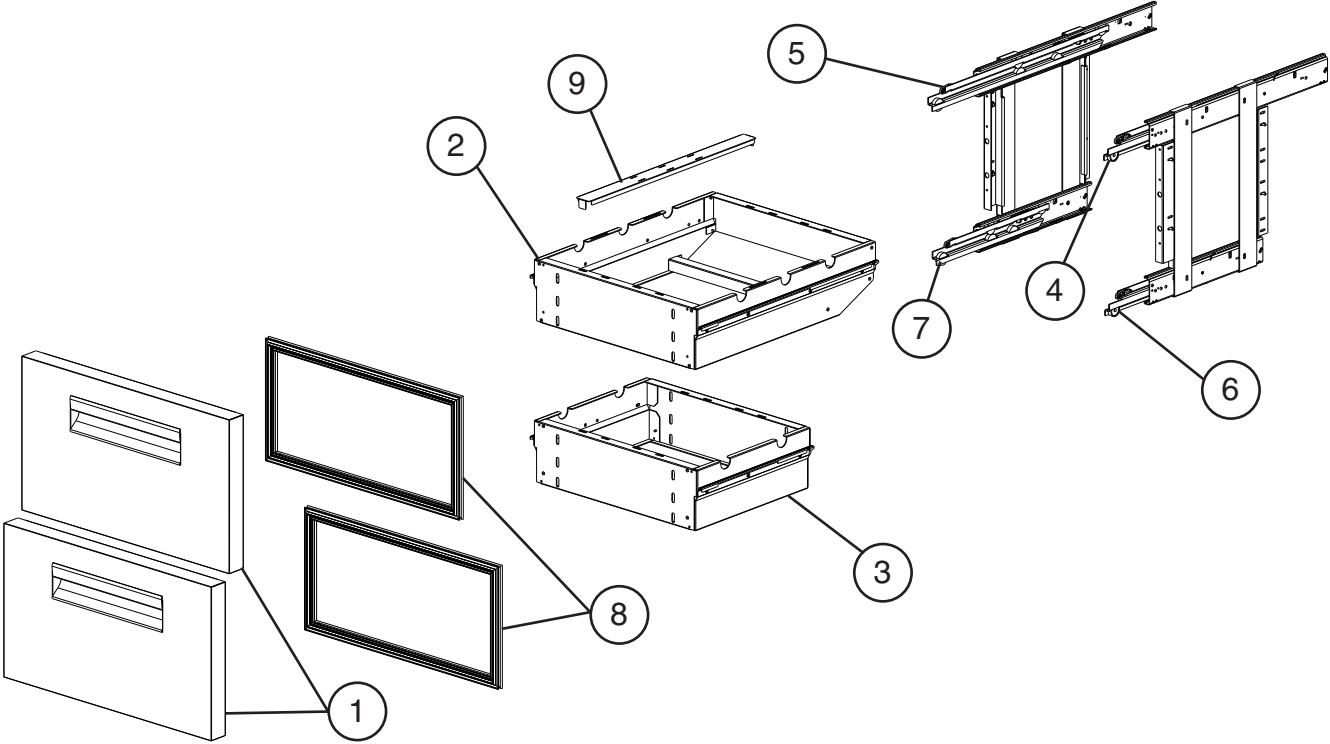

Title: G. Drawer Models: Undercounter, Worktop, Prep Table											
Index No.	Description	Material or Model Number	Part Number	Required Number							
				G-5 to J-5(B)	J-5(C) to L-5						
1	Drawer Face	_R27A-xx(M(D2)), and _F27A-D2 UC/WT/Prep Table	2A7510G01	2	2						
		_R48A-xx(M(Dx)), _F48A-D4, and _R72A-xx(M(Dx)) UC/WT/Prep Table	2A7511G01	2	2						
		_R60A-xx(M(Dx)) UC/WT/Prep Table	2A7512G01	2	2						
2	Upper Drawer Box	_R27A-xx(M(D2)), and _F27A-D2 UC/WT/Prep Table	3A9501G01	1	1						
		_R48A-xx(M(Dx)), _F48A-D4, and _R72A-xx(M(Dx)) UC/WT/Prep Table	3A9500G01	1	1						
		_R60A-xx(M(Dx)) UC/WT/Prep Table	3A9502G01	1	1						
3	Lower Drawer Box	_R27A-xx(M(D2)), and _F27A-D2 UC/WT/Prep Table	3A8185G01	1	1						
		_R48A-xx(M(Dx)), _F48A-D4, and _R72A-xx(M(Dx)) UC/WT/Prep Table	3A8191G01	1	1						
		_R60A-xx(M(Dx)) UC/WT/Prep Table	3A8294G01	1	1						
4	Upper Right Slide Roller		4A6146-02	1	1						
5	Upper Left Slide Roller		4A6147-02	1	1						
6	Lower Right Slide Roller		4A5663-02	1	1						
7	Lower Left Slide Roller		4A5664-02	1	1						
8	Gasket	_R27A-xx(M(D2)), and _F27A-D2 UC/WT/Prep Table	2A5192-15	2	2						
		_R48A-xx(M(Dx)), _F48A-D4, and _R72A-xx(M(Dx)) UC/WT/Prep Table	2A5192-17	2	2						
		_R60A-xx(M(Dx)) UC/WT/Prep Table	2A5192-16	2	2						
9	Upper Drawer Divider	_R27A-xx(M(D2)), _F27A-D2, and _R60A-xx(M(Dx)) UC/WT/Prep Table	3A9645-01		1						
		_R48A-xx(M(Dx)), _F48A-D4, and _R72A-xx(M(Dx)) UC/WT/Prep Table	3A9645-02		1						

H. Accessories & Labels
Undercounter, Worktop, Prep Table
G-5 to L-5

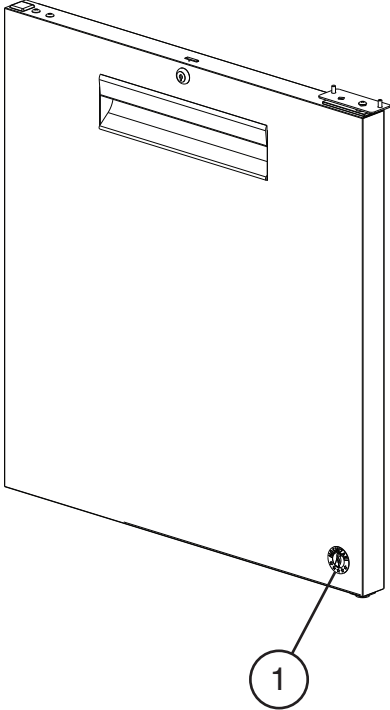
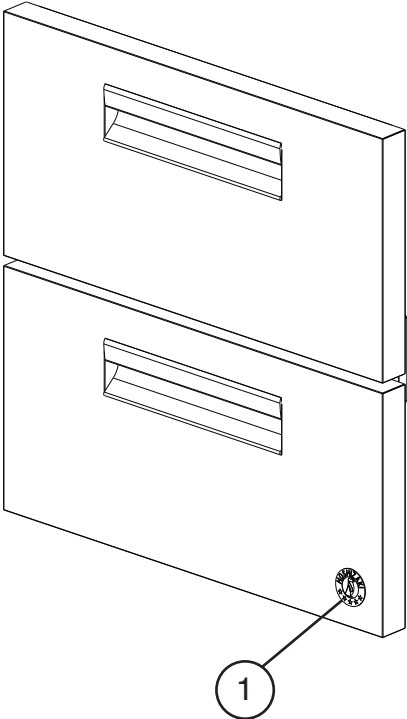

Title: H. Accessories & Labels		Models: Undercounter, Worktop, Prep Table																				
Index No.	Description	Material or Model Number	Part Number	Required Number																		
				G-5 to L-5																		
1	Penguin Label		475552L01	1																		
2	4" Caster Kit (includes items 3 and 4)	HS-5035 UC	4A5434A01	1																		
	2" Caster Kit (includes items 3, 4, and 4a)	HS-5037 UC Low Profile	4A5436A01	1																		
	6" Caster Kit (includes items 3 and 4)	HS-5036 WT/Prep Table	4A5435A01	1																		
3	4" Non-Locking Caster	UC	4A5427-01	2																		
	2" Non-Locking Caster	UC Low Profile	4A5429-01	2																		
	6" Non-Locking Caster	WT/Prep Table	4A5428-01	2																		
4	4" Locking Caster	UC	4A5427-02	2																		
	2" Locking Caster	UC Low Profile	4A5429-02	2																		
	6" Locking Caster	WT/Prep Table	4A5428-02	2																		
4a	Wrench	UC Low Profile	4A5492-01	1																		
4b	Caster Bracket	_R48A-(xxxxx) and _F48A-(xxxxx) UC/WT/Prep Table	3A9099-01	2																		
Prep Table Specific Parts																						
5	1/6 Size Pan, 4" Depth	-8	1000000344	8																		
		-10		10																		
		-16		16																		
		-15M		15																		
		-12, -12M, -12D(x)		12																		
		-18, -18M, 18MD(x)		18																		
		-24M, -24MD2		24																		
		-30M, -30MD(x)		30																		
6	Cutting Board	SR27A-8(Dx) and SR27A-12(M(Dx))	3A4894-09	1																		
		SR36A-10(-15M)	3A4894-15	1																		
		SR48A-xx(M(Dx))	3A4894-10	1																		
		SR60A-xx(M(Dx))	3A4894-13	1																		
		SR72A-xx(M(Dx))	3A4894-14	1																		