

SAFETY PRECAUTIONS

Please read the following before servicing your refrigerator.

1. Check if electric leakage occurs in the set.
2. When servicing current applying parts, unplug prior to servicing.
3. If testing with power on, wear rubber gloves to prevent electric shock.
4. Be sure to check regular current, voltage, and capacity.
5. Don't touch metal products in a cold freezer compartment with wet hands. It may cause frostbite or other injury.
6. Prevent water flowing to electric elements in mechanical parts.
7. When filling the set, remove any materials on the set, especially thin plate type (ex.: glass plates or books.)
8. When servicing evaporator part, wear cotton gloves to prevent injury by sharp fins of the evaporator.
9. Do not open the sealed refrigeration system. It could cause injury or pollute the air. Leave this job to an authorized servicer with the appropriate refrigerant recovery equipment.

SERVICING PRECAUTIONS

AIR RECHARGING IN COMPRESSOR

Test the refrigeration system by connecting it electrically before beginning refilling operation. This is necessary to ascertain the function of the motor-compressor and identify defects immediately. If defects have been found, empty the old system of R134a residue by breaking off the end of the extension piece at its narrow point. (Figure 1)

Use the appropriate refrigerant recovery equipment.

Replace the filter and any damaged components. Unsolder and pull off the piece remaining inside the service tube and then attach an extension with male Hansen, and last, solder it to the same tube again. (Figure 2)

It is necessary to execute the soldering operation with valve open so that the fumes caused by oil residue can come out freely without blowholes between two tubes during heating the point to be soldered.

The extension fitted with the male Hansen is connected to the female fitting of the vacuum pump tube. (Figure 3)

Air evacuating from the system begins as soon as the pump starts. The refrigeration system must be kept under vacuum until the reading on the low-pressure gauge indicates vacuum (0 absolute, -1 atm., -760 mm Hg.)

In any case, it is advisable to keep the pump running for about 60 minutes. (Figure 4)

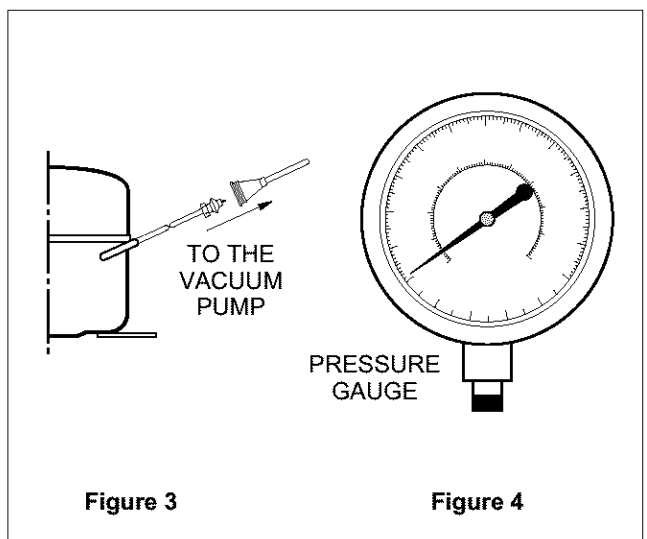
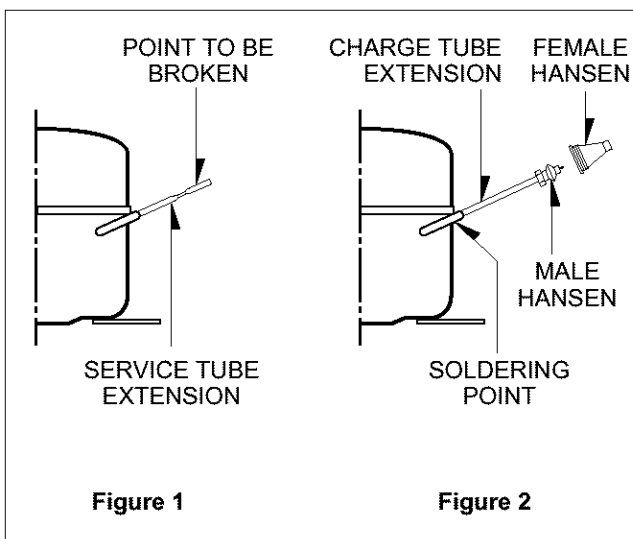

If a considerable leakage occurs, it will be necessary to stop the vacuum pump will be necessary and add a small quantity of Freon to the system, if vacuum should not be obtained (pressure gauge doesn't fall to 1 atmosphere.) Start the refrigeration unit and find the leakage with the special leak-finder. When the defective soldering point is visible, repair it after opening the extension tube valve and reestablishing the normal outside pressure inside the system.

Because the melted solder is sucked into the tubes and block them, the pressure must be rebalanced when vacuum is in the system for soldering. As soon as the vacuum operation is over, add the quantity (in grams) of R134a to the refrigeration system. Remember that every system has an exact quantity of R134a with a tolerance of ± 5 grams than can be added. (Figure 5)

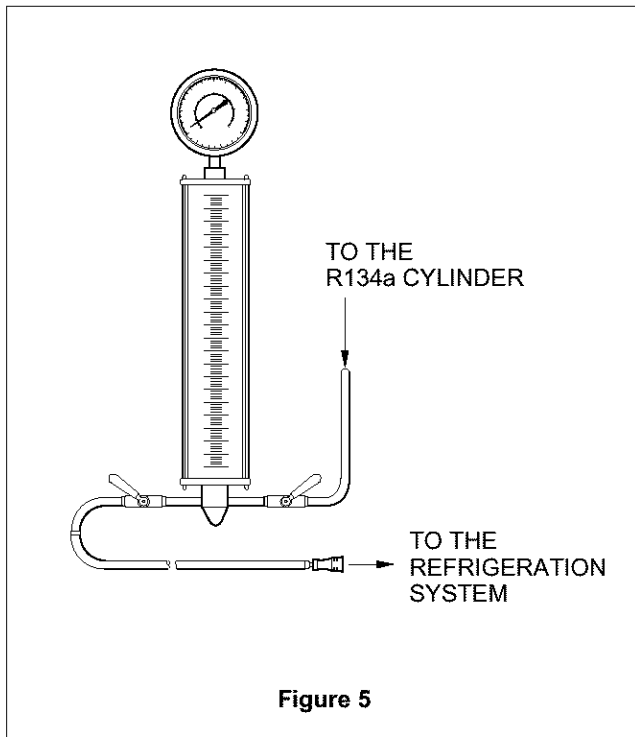

Figure 5

Before performing this operation (if the vacuum pump and refilling cylinder are connected), make sure that the valve placed between the vacuum pump and refilling tube are closed to keep the Freon from adding to the system. (Figure 6)

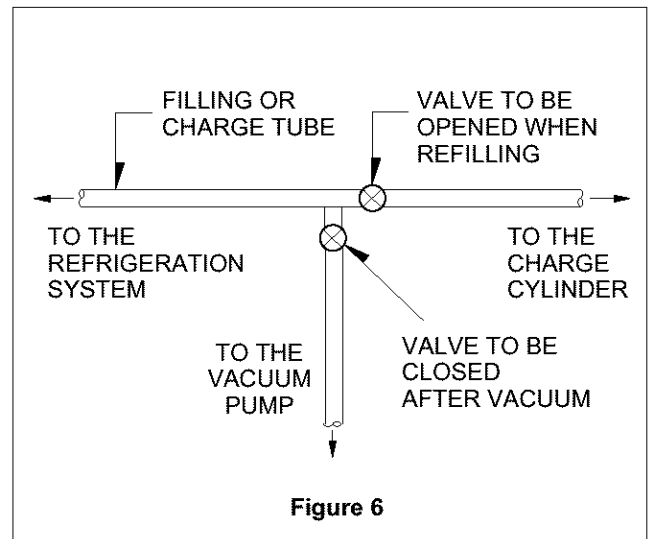

Figure 6

In addition, check the graduated scale on the cylinder for the quantity of R134a to be added; for example, if we have 750 grams of Freon in the cylinder and must add 165 grams to the group, this amount will be reached when R134a has dropped to 585 grams, remembering that the indicator shows a lower limit of meniscus. Do this after choosing the scale corresponding to the gas pressure different scales reported as the same gas pressure indicated by the pressure gauge on the top of the column. To make R134a flow into the system, open the valve placed at the base of the cylinder and connected to the filling tube. The amount of Freon cannot be added to the system all at once because it may cause a blocking of motor-compressor. Therefore, proceed by adding original quantity of about 20-30 grams and close the valve immediately thereafter.

The pressure rises and the motor-compressor must start, sucking the gas and making the pressure go down again. Regulate the valve again, maintaining the same manner until reaching the quantity of R134a established for the system being charged. When the system is running, the suction pressure must be stabilized from 0.10 to 0.4 atmosphere.

Use ONLY R134a refrigerant.

Do not substitute any other type refrigerant.

Do not mix refrigerants.

1. SPECIFICATIONS

ITEMS	SPECIFICATIONS	ITEMS	SPECIFICATIONS	
DOOR TYPE	1 DOOR	INSULATION	DOOR	POLYURETHANE
NET CAPACITY	46 l		CABINET	POLYURETHANE
CONDENSER TYPE	WALL CONDENSER (FLUSH BACK)	EVAPORATOR		ROLL BOND TYPE
DEFROSTING SYSTEM	MANUAL	DIMENSION (W X H X D)		17 ⁷ / ₁₆ X 19 ³ / ₄ X 17 ³ / ₄ in
TEMPERATURE CONTROL	KNOB DIAL	NET WEIGHT		15 Kg
		SHELF		1 PIECE
		REFRIGERANT		R-134a (43g)
		LUBRICANT	NS Series COMPRESSOR	HTS-150 (180 cc) FREOL α 22G (180 cc)

2. PARTS IDENTIFICATION

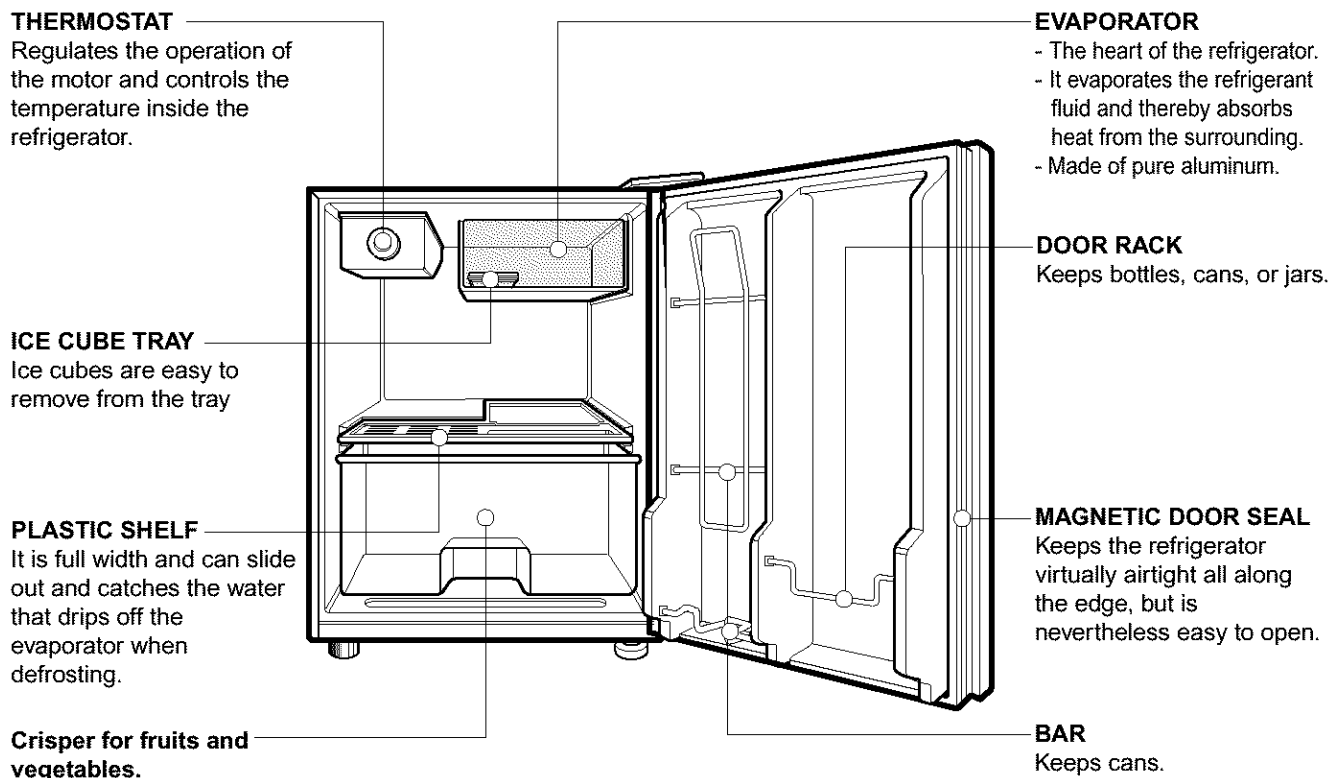

3. DISASSEMBLY

* Disconnect the power before working on the refrigerator.

A. DOOR

1. Loosen 1 screw holding an cover hinge and 3 screws holding an upper hinge to separate the door body. (Figure 7)

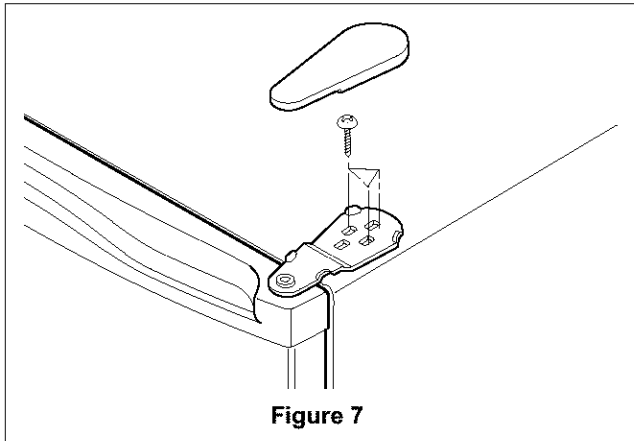

B. THERMOSTAT

1. Pull Knob Dial. (Figure 8)
2. Loosen 1 screw holding the case to remove the Thermostat cover. (Figure 9)

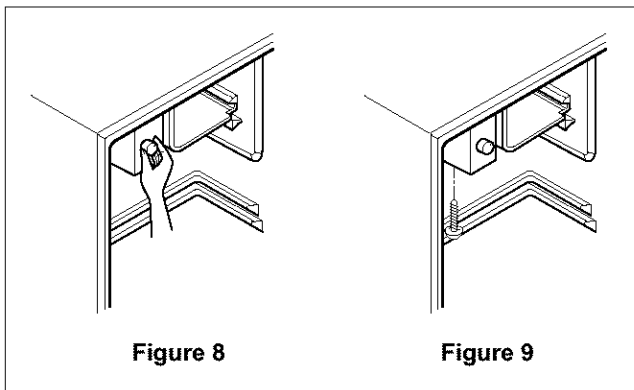

3. Pull out thermostat in the thermostat cover, and disconnect 2 or 3 lead wires. (Figure 10)

NOTE : Replace a proper specification new thermostat.

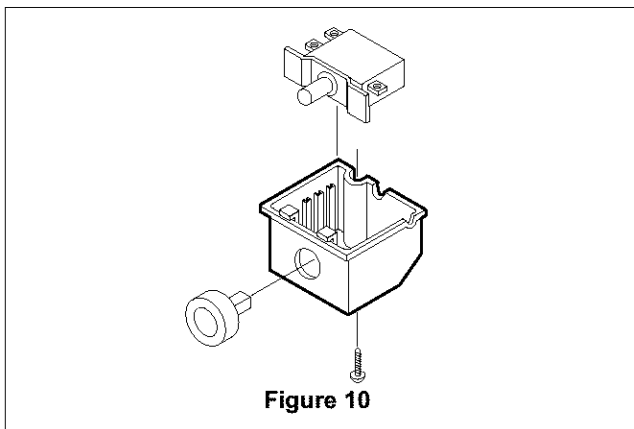

C. COMPRESSOR AND PTC

1. Remove Protector Cover, Power Cord, and Lead Wire first. (Figure 11)
2. Remove OLP.
3. Remove PTC.
4. Remove the Compressor Base by loosening 4 bolts fixed to base plate of the set. (Figure 12)

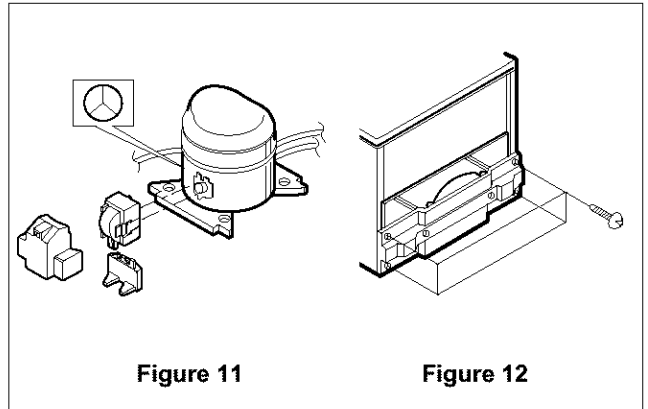

5. Remove the Compressor by loosening 2 earth screws next to Compressor.

NOTE : Replace the Compressor, after peeling off painted part of earth terminal.

- Compressor inhales the gas evaporated from Evaporator, condenses this gas and then delivers to Condenser.
- PTC is abbreviation of Positive Temperature Coefficient, is attached to the Compressor, and operates motor.
- OLP prevents Motor coil from being started inside Compressor.
- Do not turn the Adjust Screw of OLP in any way for normal operation of OLP.

4. CIRCUIT DIAGRAM

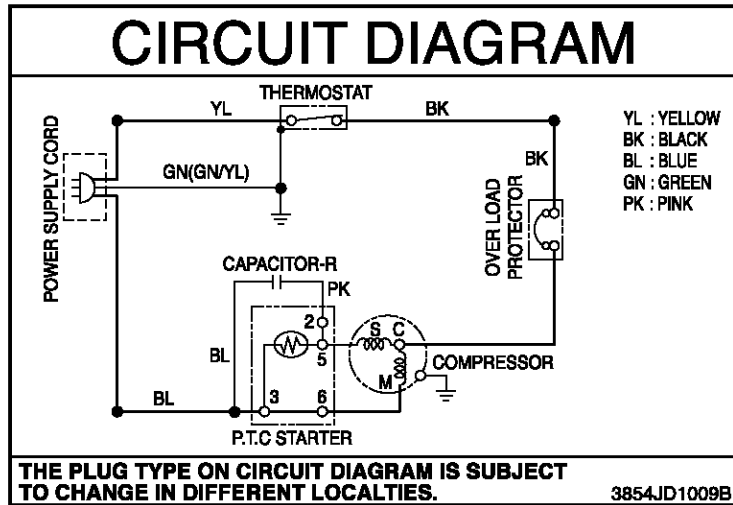

NOTE : This is a basic circuit diagram. The specifications vary in different localities.



5. TROUBLESHOOTING

DEFECT	EFFECT	CAUSE	REMEDY
SYSTEM PARTIALLY OR COMPLETELY OUT OF REFRIGERANT CHARGE	Evaporator does not frost even though motor-compressor runs continually.	An empty refrigerant system indicates a leakage of R134a. This loss is generally to be looked for at the soldering points connecting the various components or in an eventual hole in the evaporator made by the user.	Leakage must be eliminated by resoldering the defective point or substituting the damaged evaporator.
EXCESSIVELY FULL	This defect is indicated by the presence of water outside the refrigerator near the motor caused by formations of ice on the return tube.	If in the refrigerant system a quantity of R134a is introduced which is greater than that indicated, the excess gas does not terminate its expansion in the evaporator but proceeds into the return tube.	The system must be emptied and subsequently refilled introducing the correct quantity of R134a.
HUMIDITY IN THE SYSTEM	This defect is indicated by the partial frosting of the evaporator and by continual defrosting cycles determined by the interruption of the flow of gas on the evaporator. The motor compressor keeps running.	The refrigerant system is humid when there is a small percentage of water present, which, not completely retained by the dehydrator filter, enters into circulation with the Freon® and freezes at the capillary exit in the evaporator.	The system must be emptied and then refilled after eliminating the humidity.
PRESENCE OF AIR IN THE SYSTEM	Poor performance of the refrigerant system which is indicated: on the evaporator with a slight frost which does not freeze and an excessive overheating of the condenser and motor-compressor.	There is air in the refrigerating system when during the filling phase vacuum is not effected or it is not adequately done.	Group must be drained and subsequently refilled after carefully creating vacuum.
BLOCKED CAPILLARY	Because of the lack of circulation Freon in the system, there is no frosting of the evaporator, while a slight overheating of the first spiral of the condenser is noted.	Impurities contained in the Freon® or in the components of the refrigeration system before assembly and not retained by the filter can obstruct the capillary.	To restore the system it must be emptied, substitute the capillary or the evaporator entirely in case the capillary is coaxial with respect to the return tube, then refill it.
MOTOR-COMPRESSOR SHORT-CIRCUITED OR BLOCKED	The system does not work and the "OLP" intervenes interrupting delivery to the motor-compressor.	In case of short circuit, the breakdown is due to the electric winding. If blocked, there is a mechanical failure in the motor-compressor.	The motor-compressor must be replaced and then proceed with refilling.
MOTOR-COMPRESSOR DOSE NOT COMPRESS	No frost forms on the evaporator, even if the motor-compressor is apparently running regularly.	In this case there is a mechanical failure in the diaphragm valves which remaining continually open, do not permit the compressor to operate. Consequently, Freon® does not circulate in the system.	The motor-compressor must be replaced and then proceed with refilling.
NOISY MOTOR-COMPRESSOR	In case of mechanical failure in the motor-compressor there is an excessive noise when the system is functioning. In case a suspension spring is unhooked, banging will be heard and there will be especially strong vibrations when the system starts up and stops.	The cause of the excessive noise is normally to be sought for in a mechanical breakdown, and only rarely in the unhooking of one of the suspension springs.	The motor-compressor must be replaced and then proceed with the refilling.

NO COOLING

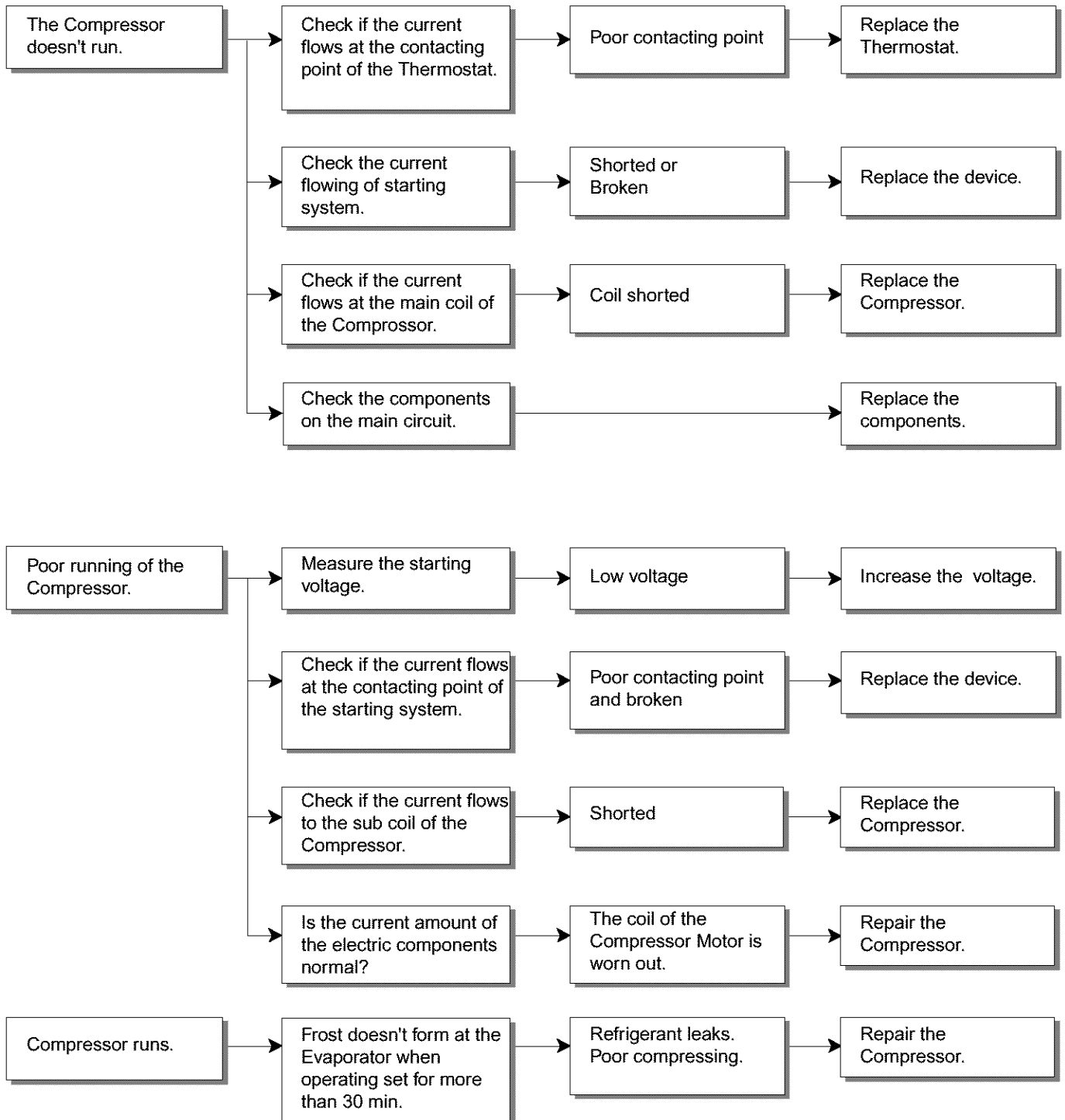

COMPRESSOR AND ANOTHER ELECTRIC COMPONENTS

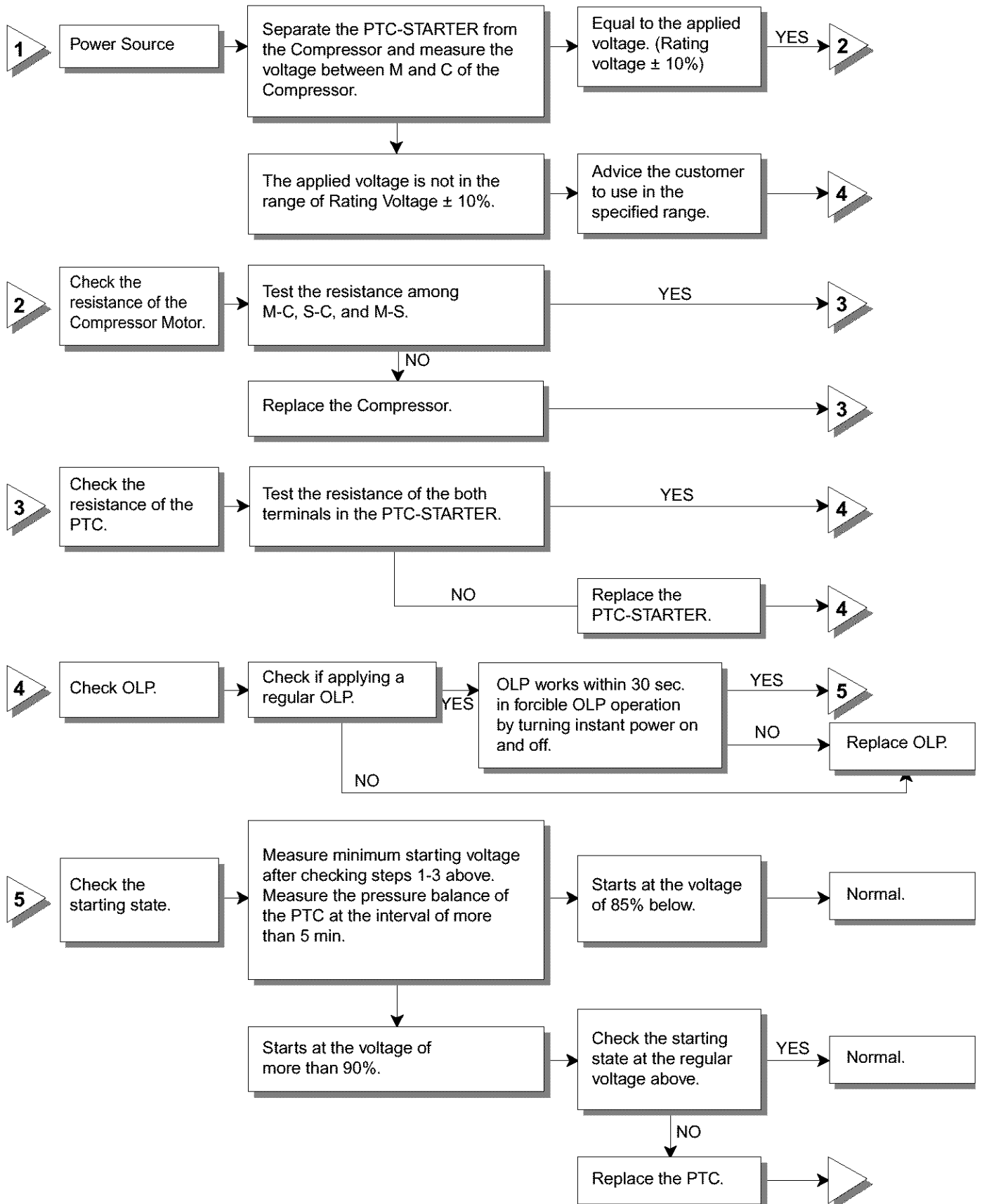

PTC

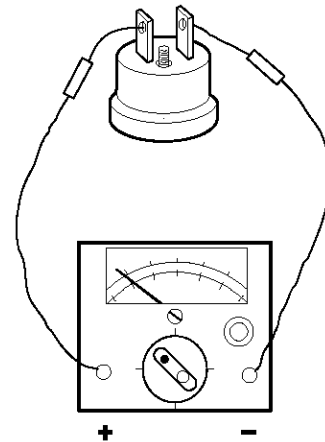
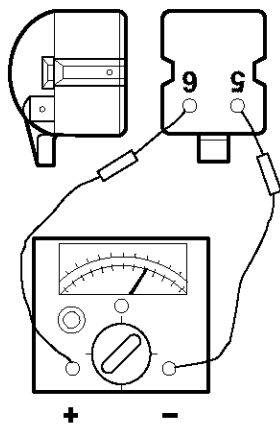
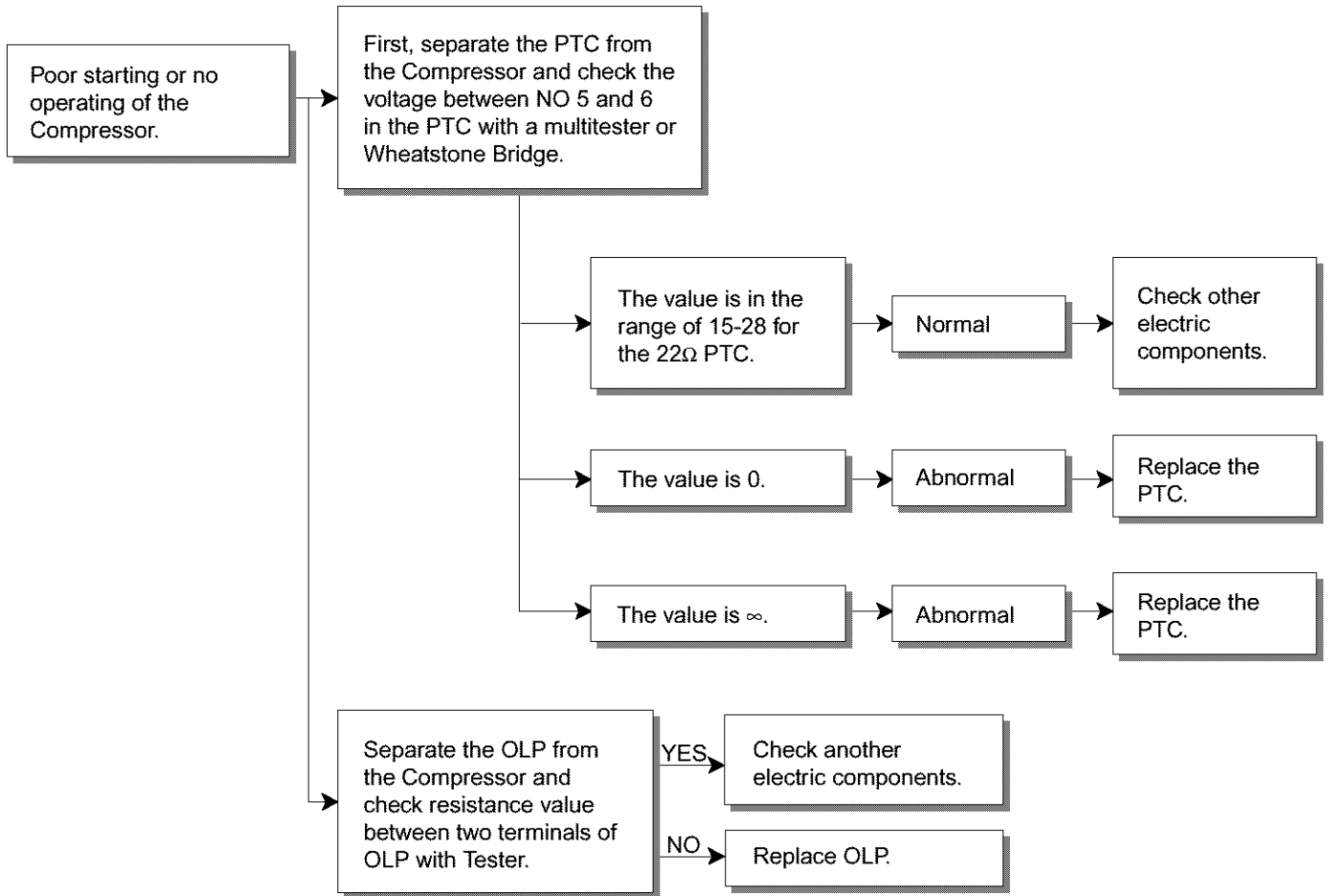

6. EXPLODED VIEW

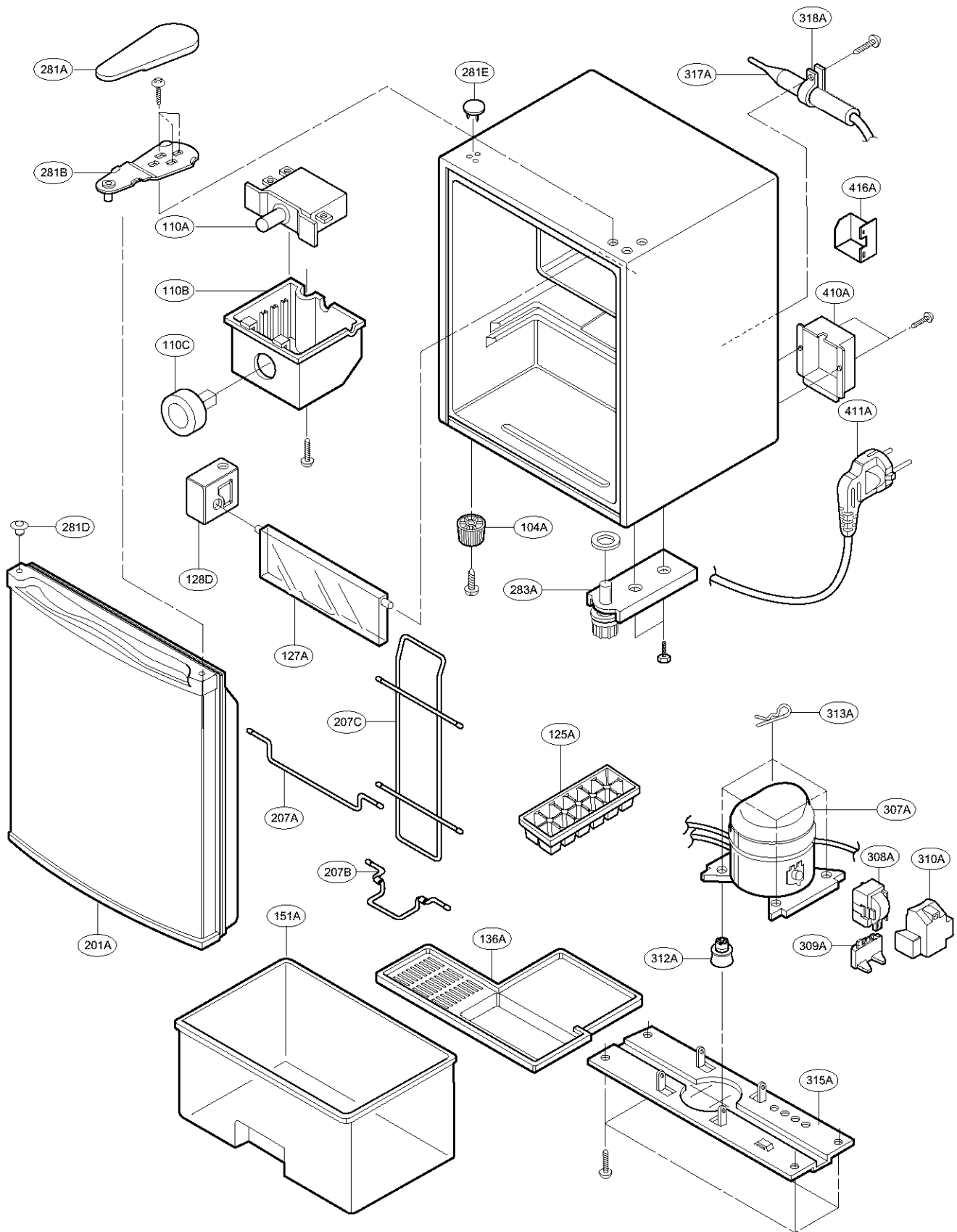

NOTE : Parts are subject to change in different localities.

