

**SEARS**

**OWNERS  
MANUAL**

**MODEL NO.  
917.255919**

**Caution:  
Read and Follow  
All Safety Rules  
And Instructions  
Before Operating  
This Equipment**



**CRAFTSMAN  
GT 18HP TWIN  
6 SPEED - 44" MOWER  
GARDEN TRACTOR**

***Assembly  
Operation  
Maintenance  
Repair and Adjustment  
Repair Parts***

*Sears, Roebuck and Co., Chicago, IL 60684 U.S.A.*



**LOOK FOR THIS SYMBOL TO POINT OUT IMPORTANT SAFETY PRECAUTIONS. IT MEANS - ATTENTION! BECOME ALERT! YOUR SAFETY IS INVOLVED.**

**CAUTION: LOOK FOR THIS WORD TO POINT OUT IMPORTANT EQUIPMENT PRECAUTIONS.**



## **RULES FOR SAFE OPERATION**

**WARNING:** This unit is equipped with an internal combustion engine and should not be used on or near any unimproved forest-covered, brush-covered or grass covered land unless the engine's exhaust system is equipped with a spark arrester meeting applicable local or area laws (if any). If a spark arrester is used, it should be maintained in effective working order by the operator).

See your local Sears Authorized Service Centre for spark arrester. See Repair Parts page 34.

1. Know the controls and how to stop quickly. **READ THIS OPERATOR'S MANUAL** and instructions furnished with attachments.
  2. Do not allow children to operate the machine. Do not allow adults to operate it without proper instruction.
  3. Do not carry passengers. Do not mow when children and others are around.
  4. Always wear substantial footwear. Do not wear loose fitting clothing that could get caught in moving parts.
  5. Keep your eyes and mind on your tractor, mower, and the area being cut. Do not let other interests distract you.
  6. Do not attempt to operate your tractor or mower when not in the drivers seat.
  7. Always get on or off your tractor from the operator's left hand side.
  8. Clear the work area of objects (wire, rocks, etc.) which might be picked up and thrown.
  9. Disengage all attachment clutches before attempting to start the engine.
  10. Disengage power to attachments and stop the engine before leaving the operator's position.
  11. Disengage power to mower, stop the engine, and disconnect spark plug wire(s) from spark plug(s) before cleaning, making an adjustment, or repair. Be careful to avoid touching hot muffler or engine components.
  12. Disengage power to attachments when transporting or not in use.
  13. Take all possible precautions when leaving the vehicle unattended. Disengage the power-take-off, lower the attachments, shift into neutral, set the parking brake, stop the engine, and remove the key.
  14. Do not stop or start suddenly when going uphill or downhill. Mow up and down the face of slopes (not greater than 15°); never across the face. Refer to page 51.
  15. Reduce speed on slopes and make turns gradually to prevent tipping or loss of control. Exercise extreme caution when changing direction on slopes.
  16. While going up or down slopes, place Gear Shift Control Lever in 1st gear position to negotiate the slope without stopping.
  17. Never mow in wet or slippery grass, when traction is unsure, or at a speed which could cause a skid.
  18. Stay alert for holes in the terrain and other hidden hazards. Keep away from drop-offs.
  19. Do not drive too close to creeks, ditches, and public highways.
  20. Exercise special care when mowing around fixed objects in order to prevent the blades from striking them. Never deliberately run tractor or mower into or over any foreign objects.
  21. Never shift gears until tractor comes to a stop.
  22. Never place hands or feet under the mower, in discharge chute, or near any moving parts while tractor or mower are running. Always keep clear of discharge chute.
  23. Use care when pulling loads or using heavy equipment.
    - a. Use only approved drawbar hitch points.
  - b. Limit loads to those you can safely control.
  - c. Do not turn sharply. Use care when backing.
  - d. Use counterweight or wheel weights when suggested in owner's manuals.
24. Watch out for traffic when crossing or near roadways.
  25. When using any attachments, never direct discharge of material toward bystanders nor allow anyone near the vehicle while in operation.
  26. Handle gasoline with care - it is highly flammable.
    - a. Use approved gasoline containers.
    - b. Never remove the fuel cap of the fuel tank or add gasoline to a running or hot engine or an engine that has not been allowed to cool for several minutes after running. Never fill tank indoors, always clean up spilled gasoline.
    - c. Open doors if the engine is run in the garage - exhaust fumes are dangerous. Do not run the engine indoors.
  27. Keep the vehicle and attachments in good operating condition, and keep safety devices in place and working.
  28. Keep all nuts, bolts, and screws tight to be sure the equipment is in safe working condition.
  29. Never store the equipment with gasoline in the tank inside a building where fumes may reach an open flame or spark. Allow the engine to cool before storing in any enclosure.
  30. To reduce fire hazard, keep the engine free of grass, leaves, or excessive grease. Do not clean product while engine is running.
  31. Except for adjustments, **DO NOT** operate Engine if air cleaner or cover directly over carburetor air intake is removed. Removal of such part could create a fire hazard.
  32. Do not operate without a muffler, or tamper with exhaust system. Damaged mufflers or spark arresters could create a fire hazard. Inspect periodically and replace if necessary.
  33. The vehicle and attachments should be stopped and inspected for damage after striking a foreign object, and the damage should be repaired before restarting and operating the equipment.
  34. Do not change the engine governor settings or overspeed the engine; severe damage or injury may result.
  35. When using the vehicle with mower, proceed as follows:
    - a. Mow only in daylight or in good artificial light.
    - b. Shut the Engine off when unclogging chute.
    - c. Check the blade mounting bolts for proper tightness at frequent intervals.
  36. Do not operate the mower without either the entire grass catcher, on mowers so equipped, or the the deflector shield in place.
  37. Disengage power to mower before backing up. Do not mow in reverse unless absolutely necessary and then only after careful observation of the entire area behind the mower.
  38. Under normal usage the grass catcher bag material is subject to deterioration and wear. It should be checked frequently for bag replacement. Replacement bags should be checked to ensure compliance with the original manufacturer's recommendations or specifications.

**CONGRATULATIONS** on your purchase of a Sears GT 18HP Garden Tractor. It has been designed, engineered and manufactured to give you the best possible dependability and performance.

Should you experience any problem you cannot easily remedy, please contact your nearest Sears Service Department. We have competent, well-trained technicians and the proper tools to service or repair this unit.

Please read and retain this manual. The instructions will enable you to assemble and maintain your Tractor properly. Always observe the "SAFETY RULES".

MODEL NUMBER \_\_\_\_\_  
SERIAL NUMBER \_\_\_\_\_  
DATE OF PURCHASE \_\_\_\_\_

THE MODEL AND SERIAL NUMBERS WILL BE FOUND ON THE MODEL PLATE ATTACHED TO THE FENDER.

YOU SHOULD RECORD BOTH SERIAL NUMBER AND DATE OF PURCHASE AND KEEP IN A SAFE PLACE FOR FUTURE REFERENCE.

## MAINTENANCE AGREEMENT

A Sears Maintenance Agreement is available on this product. Contact your nearest Sears store for details.

## YOUR NEW GT 18 HP GARDEN TRACTOR FEATURES...

**CRAFTSMAN 18 H.P. TWIN—CYLINDER ENGINE**--cool-running performance and long life with plenty of power to take on a variety of yard, gardening or snow removal tasks.

**ALL GEAR TRANSAXLE**--six speeds forward, two reverse speeds--to let you select the proper speed for the terrain and the job. Automotive--type differential helps guard against turf scuffing

**CONTROL PANEL**--with Throttle, Choke, Light Switch, Ignition Switch, Parking Brake Lever and Clutch Switch--conveniently grouped for ease of use.

**ATTACHMENT VERSATILITY**--handles a large variety of Sears Yard and Garden Tractor Attachments See pages 49-50.

## CUSTOMER RESPONSIBILITIES

Read and observe the safety rules. Always use care when using your tractor. Keep away from moving parts. **DO NOT** work on your tractor with engine running. Always keep your tractor and mower clean. Follow a regular schedule in maintaining, caring for and using your tractor. A well cared for tractor will run and last longer. Follow the instructions under "Maintenance" and "Storage" sections of this Owner's Manual.

### LIMITED TWO YEAR WARRANTY ON ELECTRIC START RIDING EQUIPMENT

For two years from date of purchase, when this riding equipment is maintained, lubricated, and tuned up according to the operating and maintenance instruction in the owner's manual, Sears will repair free of charge any defect in material or workmanship in this electric start riding equipment.

This warranty excludes blade(s), blade adapter(s), spark plug(s), air cleaner and belt(s), which are expendable and become worn during normal use.

This warranty does not cover:

- Tire replacement or repair caused by punctures from outside objects (such as nails, thorns, stumps, or glass); and
- repairs necessary because of operator abuse or negligence, including the failure to maintain the equipment according to instructions contained in the owner's manual; and
- riding equipment used for commercial or rental purposes.

### FULL 90-DAY WARRANTY ON BATTERY

For 90 days from the date of purchase, if any battery included with this riding equipment proves defective in material or workmanship and our testing determines the battery will not hold a charge, Sears will replace the battery at no charge.

WARRANTY SERVICE IS AVAILABLE BY CONTACTING THE NEAREST SEARS SERVICE CENTER/DEPARTMENT IN THE UNITED STATES. This warranty applies only while this product is in use in the United States.

This warranty gives you specific legal rights, and you may also have other rights which may vary from state to state.

SEARS, ROEBUCK and CO., D/698-731A, Sears Tower, Chicago, Il 60684

# INDEX

<b>A</b>		<b>F</b>		Stopping Your Tractor . . . . .	12
Adjustments:		Filter, Air . . . . .	17	Tractor Operation on Hills . . . . .	14
Attachment Lift Spring . . . . .	25	Fuel:		Options	
Brake . . . . .	16	Type . . . . .	12	Attachments . . . . .	49,50
Carburetor . . . . .	20	Storage . . . . .	26	Spark Arrester . . . . .	2
Electric Clutch . . . . .	21	Fuse . . . . .	23		
Gauge Wheels . . . . .	13			<b>P</b>	
Mower Drive Belt . . . . .	10			Parts Bag . . . . .	5,6
Mower		<b>G</b>			
Front-To-Rear . . . . .	24	Gauge Wheels . . . . .	13		
Side-To-Side . . . . .	24			<b>H</b>	
Throttle Control Cable . . . . .	20			Hood Removal . . . . .	23
Air Filter					
Cleaning . . . . .	17	<b>L</b>			
Paper Cartridge . . . . .	17	Lubrication:			
Air Intake Screen, Engine . . . . .	19	Chart . . . . .	18		
Assembly . . . . .	5-10	Steering & Front Wheels . . . . .	19		
Attachment Lift Spring Adjustment . . . . .	25	Tractor Pivot Points . . . . .	18	<b>R</b>	
Attachments . . . . .	49-50			Repair and Adjustments . . . . .	20-26
				Attachment Lift Spring . . . . .	25
<b>B</b>				Blade Drive Belt . . . . .	25
Battery:				Blade . . . . .	26
Charging . . . . .	7			Carburetor . . . . .	20
Cleaning . . . . .	18	<b>M</b>		Electric Clutch . . . . .	21
Installation . . . . .	8	Maintenance . . . . .	15-19	Fuse . . . . .	23
Levels . . . . .	17	Air Filter . . . . .	17	Hood Removal . . . . .	23
Preparation . . . . .	7	Air Filter Paper Cartridge . . . . .	17	Motion Drive Belt . . . . .	21
Starting with Weak Battery . . . . .	19	Air Screen . . . . .	19	Motion Drive Belt Replacement . . . . .	21
Storage . . . . .	26	Battery . . . . .	17	Mower Front-to-Rear . . . . .	24
Terminals . . . . .	18	Blade Sharpening . . . . .	17	Mower Side-to-Side . . . . .	24
Belt:		Brake Adjustment . . . . .	16	Mower Removal . . . . .	23
Blade Drive (Blade-to- Blade) . . . . .		Engine oil . . . . .	15	Throttle Control Cable . . . . .	20
Removal/Replacement . . . . .	25	Lubrication . . . . .	18	Transaxle Oil Level . . . . .	23
Motion Drive, Remove/Replace . . . . .	21	Spark Plugs . . . . .	19		
Mower Drive (Engine-to-Mower . . . . .		Tire Care . . . . .	17	<b>S</b>	
Adjustment . . . . .	10	<b>Mower:</b>		Safety Rules . . . . .	2
Mower Drive Belt Installation . . . . .	10	Adjustment, Front-to-Rear . . . . .	24	Seat . . . . .	7
Blade:		Adjustment, Side-to-Side . . . . .	24	Service Record . . . . .	28
Sharpening . . . . .	17	Blade Sharpening . . . . .	17	Slope Guide Sheet . . . . .	51
Replacement . . . . .	26	Blade Replacement . . . . .	26	Spark Plugs . . . . .	19
Brake Adjustment . . . . .	16	Cutting Level . . . . .	10	Speed Control Chart . . . . .	14
		Installation . . . . .	10	Starting the Engine . . . . .	12
<b>C</b>		Operation . . . . .	13	Steering Wheel . . . . .	8
Carburetor Adjustment . . . . .	20	Removal . . . . .	23	Stopping the Tractor . . . . .	12
Clutch, Electric, Adjustment . . . . .	21	Mowing Tips . . . . .	14	Storage . . . . .	26
Controls, Tractor . . . . .	11	Muffler . . . . .	19		
Cutting Level, Mower . . . . .	10	Spark Arrester . . . . .	2	<b>T</b>	
				Throttle Control Cable Adjustment . . . . .	20
<b>E</b>		<b>O</b>		Tires . . . . .	17
Engine:		Oil		Transaxle Oil Level . . . . .	23
Air Screen . . . . .	19	Cold Weather Conditions . . . . .	16	Trouble Shooting Chart . . . . .	27
Oil Change . . . . .	18	Engine . . . . .	15		
Oil Level . . . . .	16	Transaxle . . . . .	23	<b>W</b>	
Oil Type . . . . .	16	Storage . . . . .	26	Warranty . . . . .	3
Starting . . . . .	12	Operation . . . . .	11-14	Wiring (Schematic) . . . . .	29
Storage . . . . .	26	Operating/Tractor and Mower . . . . .	13		
		Speed . . . . .	14		
		Starting the Engine . . . . .	12		

# ASSEMBLY

## Unpacking Instructions





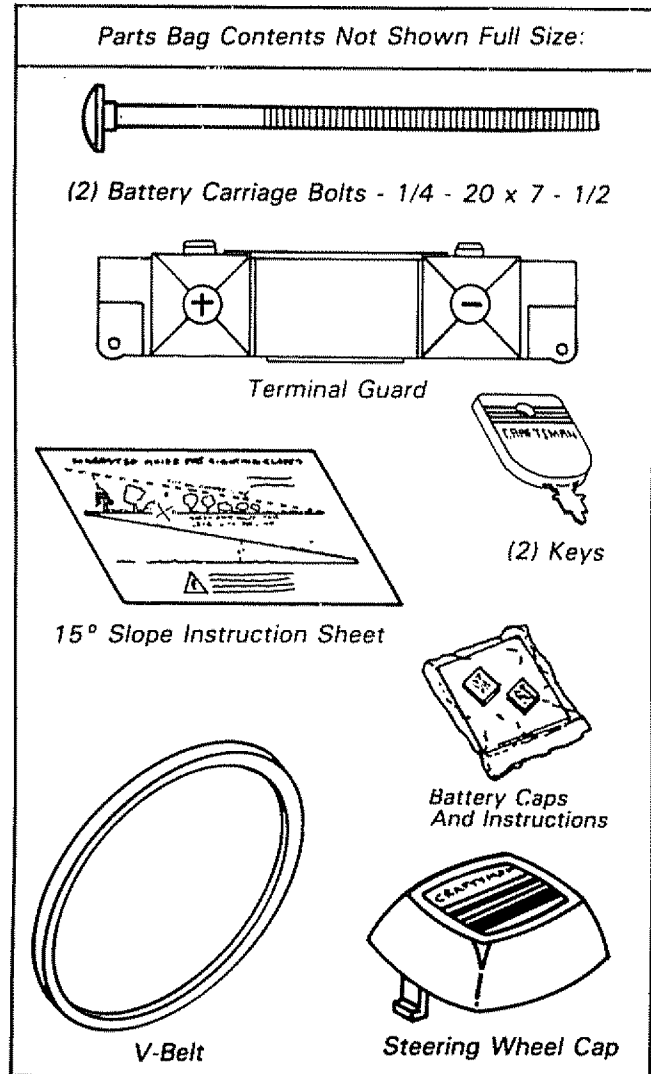
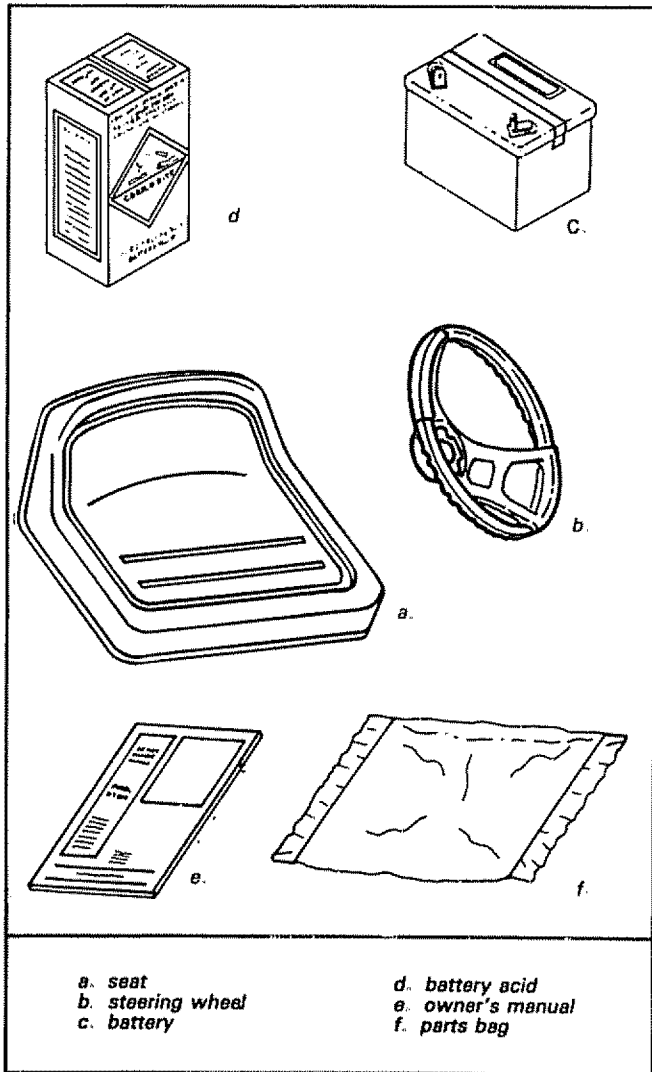

1. Remove box from carton. The box contains the items shown below.
2. Cut down four corners of the carton with a utility knife and fold down sides.
3. Remove mower deck from skid.
4. Shift tractor into "N" neutral position and release parking brake
5. Carefully guide the tractor backwards off the skid.



The operation of any tractor can result in foreign objects thrown into the eyes, which can result in severe eye damage. Always wear safety glasses or eye shields before starting your tractor and while mowing. We recommend Wide Vision Safety Mask for over the spectacles or standard safety glasses, available at Sears Retail or Catalog Stores.

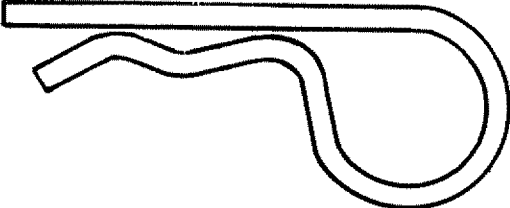
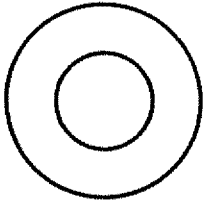
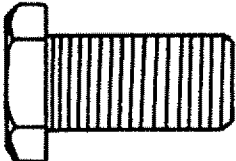

# ASSEMBLY

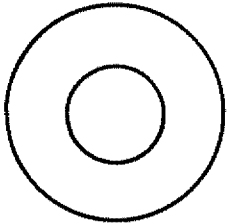
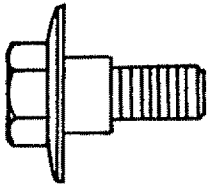
ASSEMBLY LOCATION	PARTS BAG CONTENTS SHOWN FULL SIZE
<p><b>BATTERY</b></p>	 <p>(2) Wing Nut - 1/4 - 20</p>
<p><b>BATTERY TERMINALS</b></p>	 <p>(2) Hex Bolt, 1/4 - 20 x 3/4</p>  <p>(2) Lockwasher 1/4</p>  <p>(2) Washer 9/32 x 5/8 x 16 Ga.</p>  <p>(2) Hex Nut, 1/4 - 20</p>
<p><b>SUSPENSION ARMS</b></p>	 <p>(4) Spring Retainer</p>  <p>(4) Washer 17/32 x 1 - 1/16 x 13 Ga.</p>
<p><b>SEAT</b></p>	 <p>(1) Hex Bolt, 1/2 - 13 x 1 Grade 5</p>  <p>(1) Lockwasher 1/2</p>  <p>(1) Washer 17/32 x 1-3/16 x 12 Ga.</p>  <p>(1) Shoulder bolt 5/16 - 18</p>

To assemble and adjust your tractor you will need:

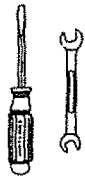

- |                    |                     |
|--------------------|---------------------|
| (2) 7/16" wrenches | (2) 1/2" wrenches   |
| (1) 3/4" wrench    | Tire Pressure Gauge |
| (2) 9/16" wrench   | Screwdriver         |
|                    | Utility Knife       |

NOTE: RIGHT HAND (R.H.) AND LEFT HAND (L.H.) ARE DETERMINED FROM OPERATOR'S POSITION WHILE SEATED ON THE TRACTOR.

**WEAR EYE AND FACE SHIELD.**



**WASH HANDS OR CLOTHING IMMEDIATELY IF ACCIDENTALLY IN CONTACT WITH BATTERY ACID.**  
**DO NOT SMOKE, FUMES FROM CHARGED BATTERY ACID ARE EXPLOSIVE.**

NOTE: THIS TRACTOR IS EQUIPPED WITH AN OPERATOR PRESENCE SENSING SWITCH. ANY ATTEMPT BY THE OPERATOR TO LEAVE THE SEAT WITH THE ENGINE RUNNING AND ATTACHMENT CLUTCH ENGAGED WILL SHUT OFF THE ENGINE.

### 1. Prepare Battery



**READ INSTRUCTIONS INCLUDED WITH THE BATTERY VENT CAPS FOUND IN BAG OF PARTS. ALWAYS WEAR GLOVES, CLOTHING AND GOGGLES TO PROTECT YOUR HANDS, SKIN AND EYES.**

- Fill and charge battery (before installing). NOTE: SEE DETAILED INSTRUCTIONS PACKAGED WITH BATTERY VENT CAPS IN BAG OF PARTS.
- Fill battery with battery acid to bottoms of tubes in cells (Fig. 1) NOTE: DO NOT OVERFILL. OVERFILLING WILL RESULT IN DAMAGE TO TRACTOR.
- Check level of battery acid after 30 minutes. Add additional battery acid if necessary. NOTE: TIGHTEN VENT CAPS SECURELY.
- It is recommended that the battery be charged before use. Charge battery at a rate of six amperes for one hour.
- Neutralize excess battery acid for disposal by adding it to four inches of water in a five gallon plastic container. Stir with a wooden or plastic paddle while adding baking soda until the addition of more soda causes no more foaming.

### 2. Install Seat

Seat position should be adjusted forward or backward so that the operator can comfortably reach Clutch/Brake Pedal and safely operate the tractor (Fig. 2).

- Place Seat on Seat Pan. Screw Adjustment Bolt, Flat Washer and Lockwasher, and Shoulder Bolt into Seat (Fig. 5). Adjustment Bolt, Washers, and Shoulder Bolt Found in Bag of Parts.
- Tighten Shoulder Bolt using a 1/2" wrench. Note that the Shoulder Bolt will be loose in the Seat Pan slot.
- Tighten hex bolt (adjustment bolt), lockwasher and flat washer using a 3/4" wrench.

# ASSEMBLY

- Place seat in operating position. Sit on the seat and press clutch/brake pedal all the way down. If operating position is not comfortable, adjust seat.
- To adjust: Raise seat. Loosen adjustment bolt. Slide seat to desired position. Tighten adjustment bolt securely.

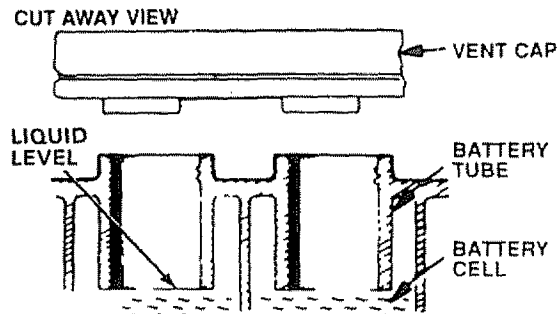

FIGURE 1

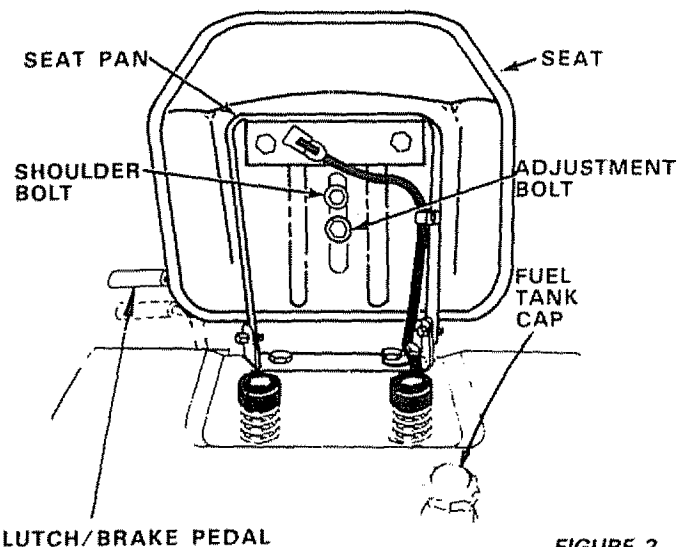

FIGURE 2



**MACHINE SCREW-LOCKWASHER-FLAT WASHER MUST BE TIGHTENED SECURELY TO PREVENT MOVEMENT OF SEAT.**

# ASSEMBLY

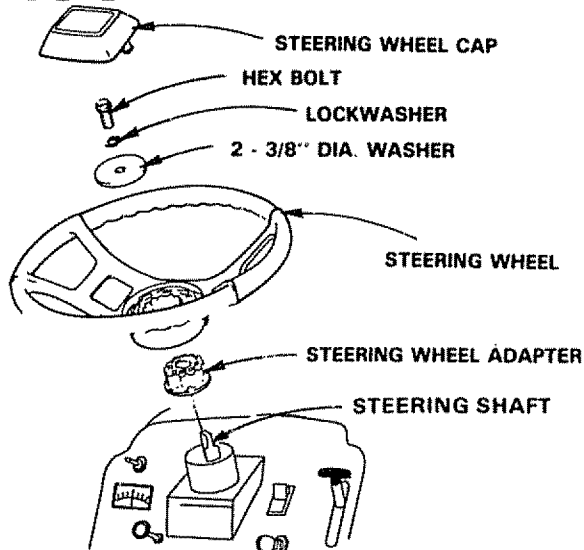

FIGURE 3

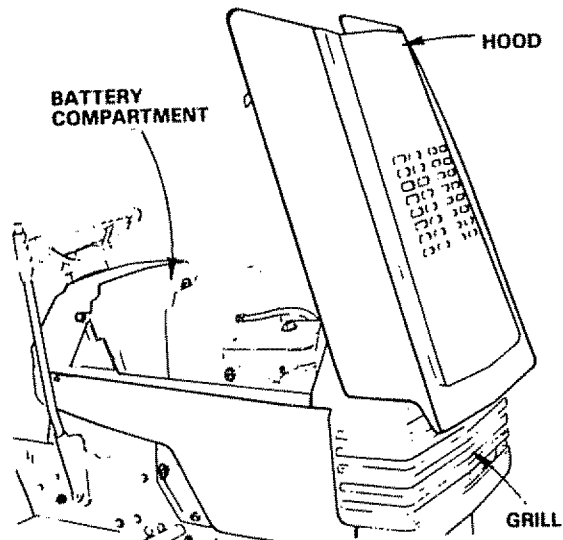

FIGURE 4

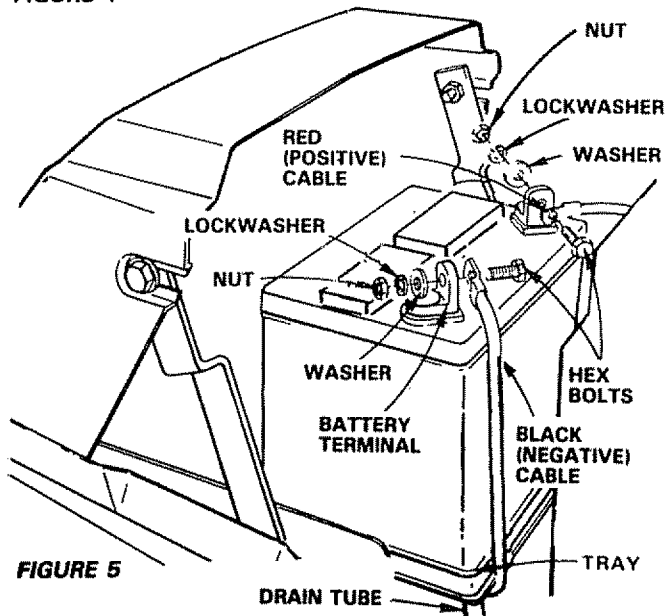
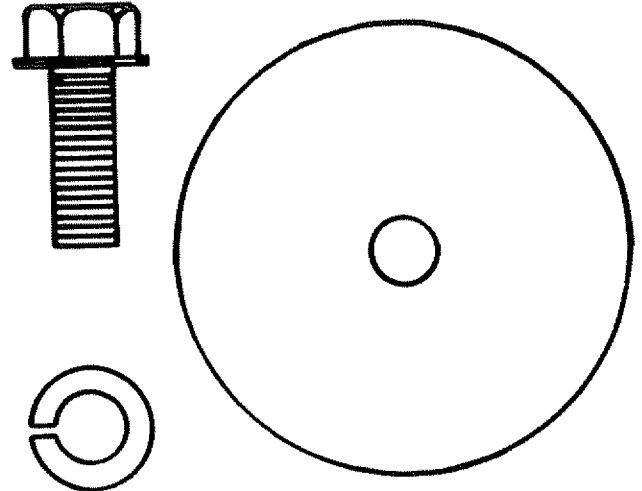

FIGURE 5

## 3. Install Steering Wheel

NOTE: POSITION FRONT WHEELS FORWARD.

- a. Use a 9/16" wrench to remove hex bolt, lockwasher and 2-3/8" diameter washer (shown full size below) from steering shaft (Fig. 3)



- b. Position steering wheel over steering adaptor.
- c. Secure steering wheel to steering shaft using hex bolt, lockwasher and 2-3/8" diameter washer (Fig. 3).
- d. Snap steering wheel cap in place on steering wheel. Steering wheel cap found in bag of parts.

## 4. Check Tires

Reduce tire pressure to 14 PSI in front and 10 PSI in rear tires. (Tires were overinflated for shipping purposes).

**DO NOT SHORT BATTERY TERMINALS.**



**BEFORE INSTALLING BATTERY, REMOVE METAL BRACELETS, WRISTWATCH BANDS, RINGS, ETC.**

## 5. Install Battery

- a. Remove hood - See page 23.
- b. Remove tape from plastic tray. Make sure drain tube (Fig. 5) is fastened to drain hole in battery tray and battery tray is positioned in hole of battery support.
- c. Place battery in plastic tray (Battery terminals to front of tractor)(Fig. 5).

# ASSEMBLY



**POSITIVE TERMINAL MUST BE CONNECTED FIRST TO PREVENT SPARKS FROM ACCIDENTAL GROUNDING.**

- d. Connect RED battery cable to positive (+) battery terminal with hex bolt, flat washer, lockwasher and hex nut (shown full size on page 6) found in bag of parts (Fig. 6). Tighten securely with two 7/16" wrenches.
- e. Connect BLACK ground cable to negative (-) battery terminal with remaining hex bolt, flat washer, lockwasher and hex nut (shown full size on page 6) found in bag of parts (Fig. 6). Tighten securely.

NOTE: IF YOU HAVE A WEAK BATTERY, SEE "STARTING YOUR TRACTOR WITH A WEAK BATTERY" PAGE 19

- f. Using the square hole on one side of the battery support (Fig. 6) insert one battery bolt, head of bolt down. Fasten the battery bolt to the terminal guard using wing nut as shown in (Fig. 6).
- g. Assemble the remaining battery bolt to other side of battery support and fasten terminal guard to it with remaining wing nut. Tighten wing nuts securely by hand (Fig. 6).

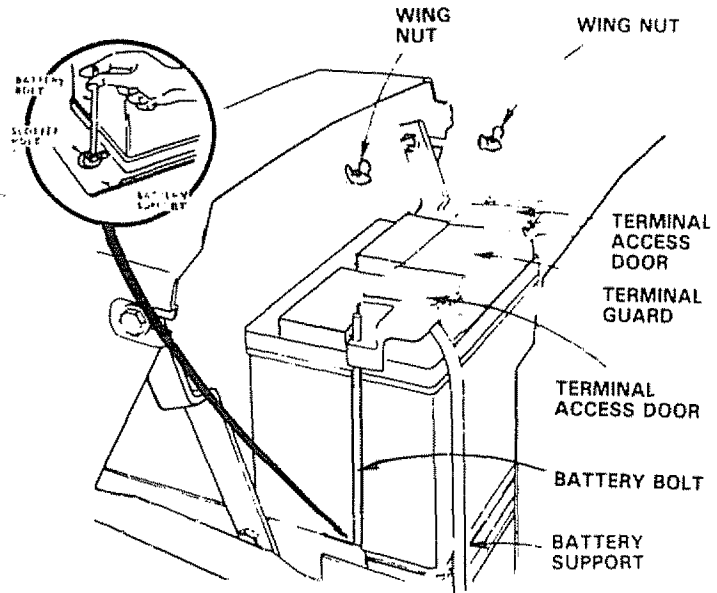
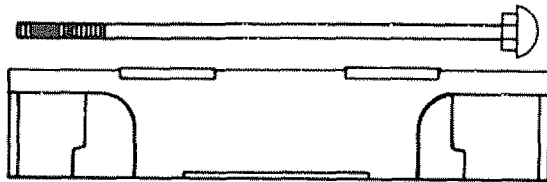

FIGURE 6



h. Remove Plastic on tractor hood and close

NOTE: USE TERMINAL ACCESS DOORS (FIG. 6) FOR:

1. INSPECTION FOR SECURE CONNECTIONS (TIGHTEN HARDWARE)
2. INSPECTION FOR CORROSION
3. TESTING BATTERY
4. JUMPING (IF REQUIRED)
5. CHARGING (IF REQUIRED)



**KEEP TERMINAL ACCESS DOORS CLOSED WHEN NOT IN USE. DO NOT START ENGINE UNTIL MOWER SUSPENSION BRACKET HAS BEEN RELEASED. SEE MOWER DRIVE BELT INSTALLATION, PAGE 10.**

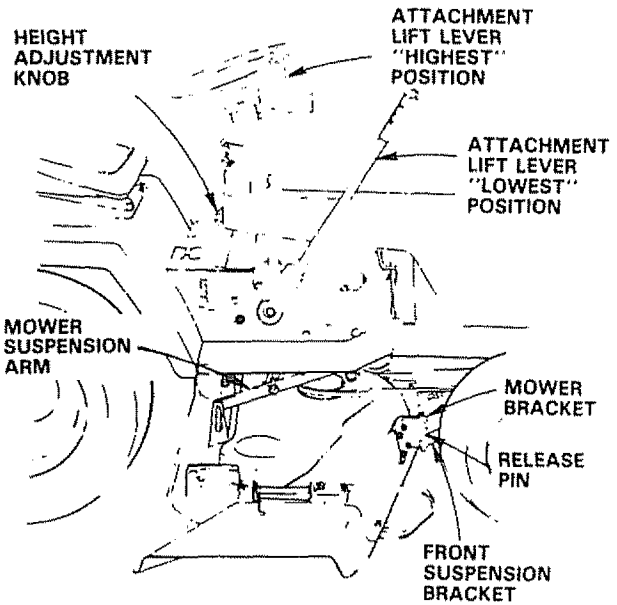

FIGURE 7

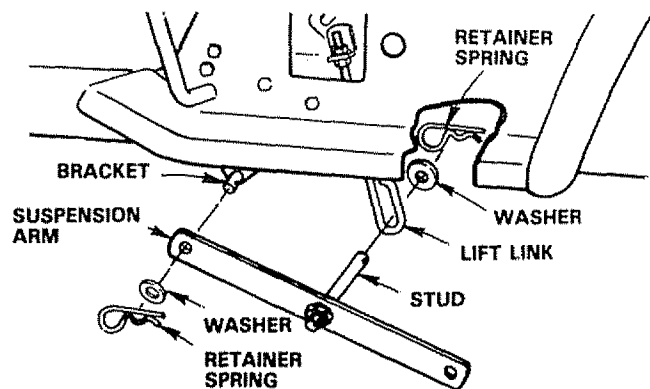

FIGURE 8



# ASSEMBLY

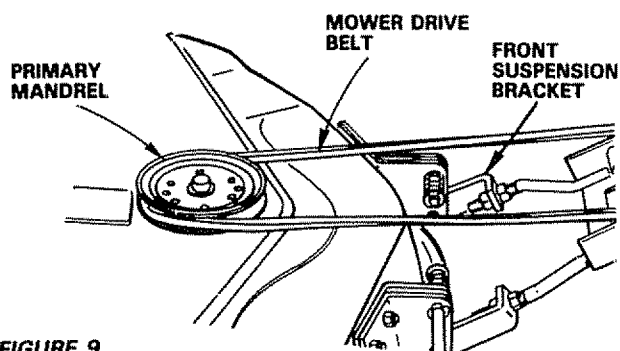

FIGURE 9

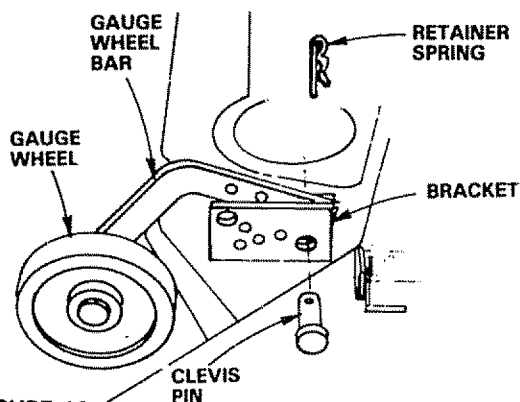

FIGURE 10

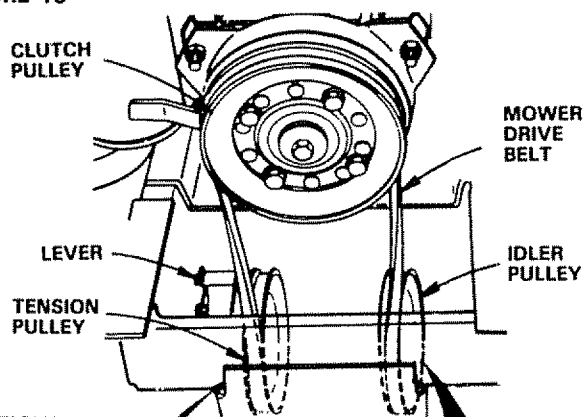
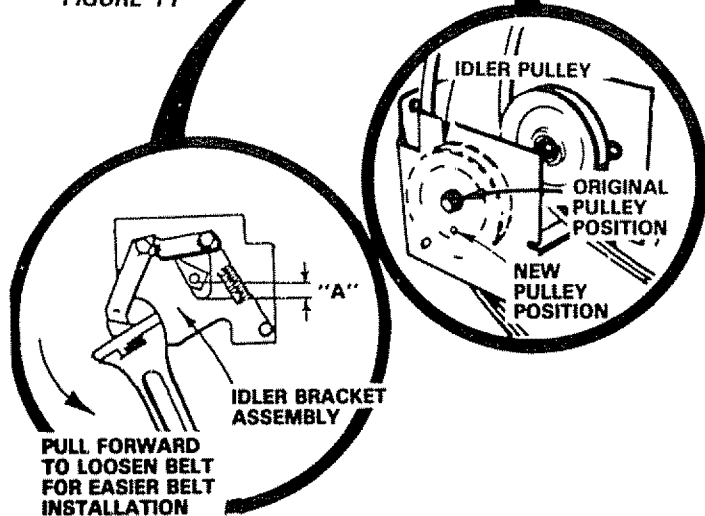



FIGURE 11



## 6. Mower Installation

- Remove band from mower suspension bracket.
- Remove banding from suspension arms (Fig. 7).
- Slide mower under tractor, deflector to R.H. side.
- Slide front suspension brackets into mower brackets. Retain with release pins (Fig. 7).
- Turn depth adjustment knob counterclockwise (  ) until it stops.
- Push attachment lift lever forward to lower mower to ground (page 11).
- Slide studs through lift links on both sides of tractor (Fig. 8). Retain with washers and retainer springs found in bag of parts.
- Place the suspension arms on brackets on both sides of frame (Fig. 8). Retain with washers and retainer springs found in bag of parts.
- Turn height adjustment knob (Fig. 7) clockwise (  ) to remove slack from mower suspension.
- Roll drive belt over primary mandrel (Fig. 9).

## 7. Mower Drive Belt Installation

- Remove hood and grill (See page 23).
- Pull mower drive belt over front mower suspension bracket (Fig. 9).
- Place mower drive belt over clutch pulley and under idler pulley and tension pulley (Fig. 11). NOTE: PULL LEVER UP TO SWING TENSION PULLEY FOR BELT CLEARANCE. Make sure narrow "V" side of belt is engaged in each pulley.
- Replace hood and grill.

## 8. Mower Drive Belt Adjustment

- Lower mower using attachment lift lever.
- If dimension "A" on idler bracket assembly measures 1/4" or less, mower drive belt must be adjusted (Fig. 11-Inset).
- Disengage attachment clutch switch.
- Using two 9/16" wrenches, remove bolt, (2) washers, lockwasher and nut from idler pulley (Fig. 11-Inset) (original position).
- Place v-belt and idler pulley in "NEW" pulley position (Fig. 11-Inset). Replace bolt, (2) washers, lockwasher and nut. Tighten securely.
- Check v-belt for proper installation on all pulley grooves.

## 9. Check the Cutting Level

The blade housing was set at the factory to cut level. After mowing a short distance, look at the area that was cut. If the blade housing cuts uneven; see the instructions on "Side-to-Side And Front-to-Rear Mower Adjustment" (page 24)".

## 10. Final Assembly

- Make sure all fasteners are tight.
- Read and follow the operation instructions. Know the location and purpose of all controls.
- Check oil and gasoline before starting the tractor.

# OPERATION

## KNOW YOUR TRACTOR

**READ THIS OWNER'S MANUAL BEFORE OPERATING YOUR GARDEN TRACTOR.** If you understand the machine and its operation, you will achieve efficient and peak performance. While reading the manual, compare the illustrations with Your Garden Tractor to familiarize yourself with the location of various controls and adjustments. Study the operating instructions and safety precautions thoroughly to insure proper functioning of your Garden Tractor and to prevent injury to yourself and others. Be sure to pay strict attention to all notes and cautions; they are included for your safety. Save this manual for future reference.

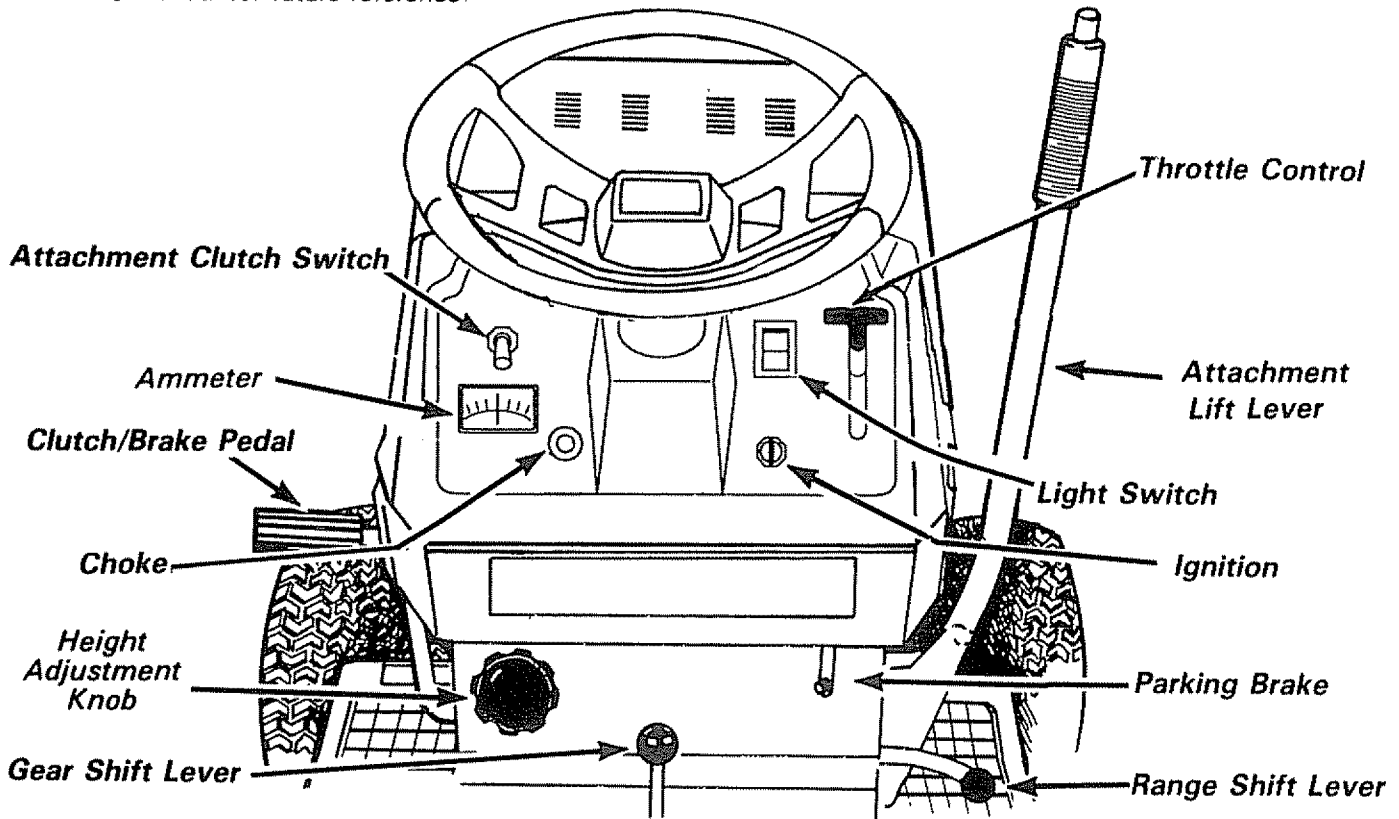

**ATTACHMENT CLUTCH SWITCH:** Pull switch out and up to engage attachment. There will be an engine hesitation as the clutch engages.

**ATTACHMENT LIFT LEVER:** Use the attachment lift lever to raise and lower the attachment mounted to your tractor. Move the lift lever forward to lower attachment.

**CHOKER:** To start a cold engine, pull choke out to engage.

**CLUTCH/BRAKE PEDAL:** The pedal has 2 functions: a clutch and a brake. To engage push the pedal completely down.

**HEIGHT ADJUSTMENT KNOB:** Use the height adjustment knob to adjust the mower height. With attachment lift lever in the full "UP" position, turn clockwise (↻) to raise mower and counterclockwise (↻) to lower mower.

**GEARSHIFT:** Press the clutch/brake pedal down firmly and move gear shift lever to desired speed.

**IGNITION:** Place key in ignition and turn to the right to start.

**AMMETER:** Each time you start your tractor, check your ammeter. The needle should move towards the (+) charging mark indicating the battery is being charged as you operate the tractor. The headlights will not show a discharge on the ammeter because they are not connected to the battery (they have their own electrical source).

**LIGHT SWITCH:** Turns on and off the headlights.

**PARKING BRAKE LOCK:** To set the parking brake, push the clutch/brake pedal completely forward. Place the parking brake lever in "Engaged" position and release pressure from pedal. Clutch/brake pedal will remain in brake position.

**RANGE SHIFT LEVER:** The Hi-Lo range shift lever gives you the versatility of 6 speed selections: Lo 1, 2, 3, and Hi 1, 2, 3.

**THROTTLE CONTROL:** Use the throttle control to increase or decrease the speed of the engine.

# OPERATION

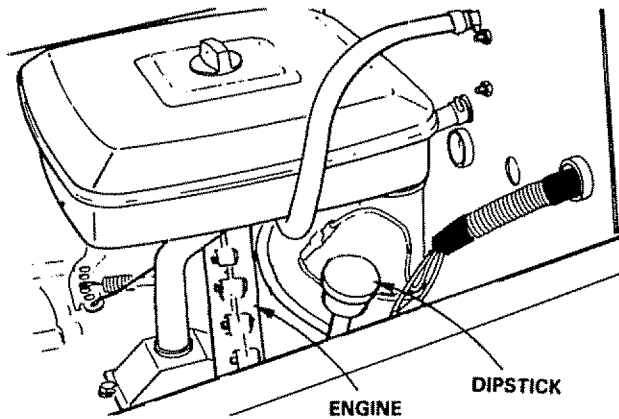

FIGURE 12

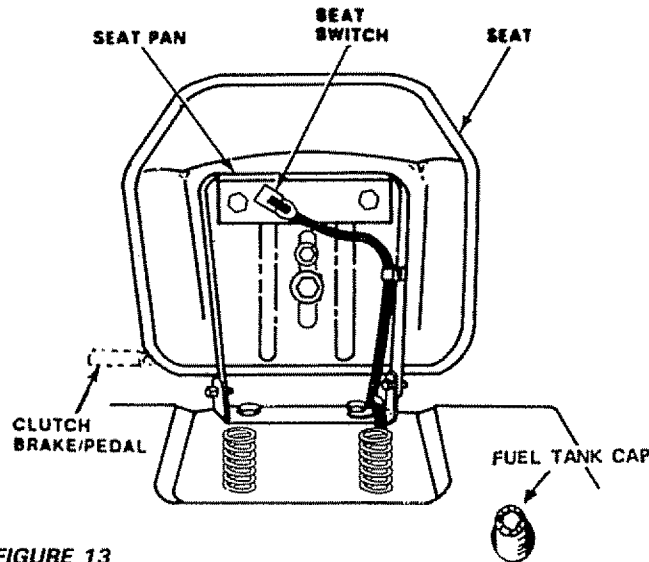

FIGURE 13

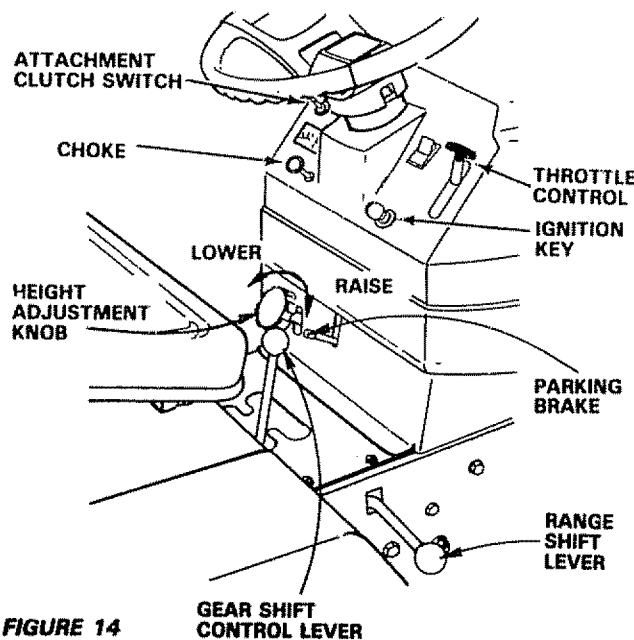

FIGURE 14

## 1. Stopping Your Tractor

NOTE: REMOVE KEY WHEN LEAVING TRACTOR TO PREVENT UNAUTHORIZED USE.

- Push clutch/brake pedal into full "BRAKE" position.
- Place parking brake in "ENGAGED" position and release pressure from clutch/brake. Pedal should remain in "BRAKE" position. NOTE: MAKE SURE PARKING BRAKE WILL HOLD TRACTOR SECURE.
- Move gear shift lever to "NEUTRAL" position.
- Place attachment clutch switch in "DISENGAGED" position.
- Move throttle control to "S" (slow) position.
- Turn ignition key to "OFF" position. Never use choke to stop engine.

## 2. Starting The Engine



**LEARN TO START, STOP AND REVERSE YOUR TRACTOR IN A LARGE, OPEN AREA.**

NOTE: THIS TRACTOR IS EQUIPPED WITH INTERLOCK SWITCHES TO PREVENT STARTING OF THE TRACTOR ENGINE WHILE THE ATTACHMENT CLUTCH OR THE CLUTCH/BRAKE PEDAL IS ENGAGED.



**IMMEDIATELY REPLACE SWITCHES THAT ARE NOT IN PROPER WORKING ORDER. DO NOT ATTEMPT TO DEFEAT THE PURPOSE OF THESE SWITCHES.**

- This engine has been shipped filled with summer weight oil (for cold weather operation see Chart page 16). Check engine oil level with tractor on level ground. Wipe dipstick (Fig. 12) clean, screw it in tight for a few seconds, remove and read oil level. If necessary, add oil until "FULL" mark is reached.

CAUTION: EXPERIENCE INDICATES THAT ALCOHOL BLENDED FUELS (CALLED GASOHOL OR USING ETHANOL OR METHANOL) CAN ATTRACT MOISTURE WHICH LEADS TO SEPARATION AND FORMATION OF ACIDS DURING STORAGE. ACIDIC GAS CAN DAMAGE THE FUEL SYSTEM OF AN ENGINE WHILE IN STORAGE.

TO AVOID ENGINE PROBLEMS, THE FUEL SYSTEM SHOULD BE EMPTIED BEFORE STORAGE FOR 30 DAYS OR LONGER. DRAIN THE GAS TANK, START THE ENGINE AND LET IT RUN UNTIL THE FUEL LINES AND CARBURETOR ARE EMPTY. USE FRESH FUEL NEXT SEASON. SEE STORAGE INSTRUCTIONS FOR ADDITIONAL INFORMATION (PAGE 26).

NEVER USE ENGINE OR CARBURETOR CLEANER PRODUCTS IN THE FUEL TANK OR PERMANENT DAMAGE MAY OCCUR.



# OPERATION

- b. Fill fuel tank (Fig. 13). Use fresh, clean, regular unleaded automotive gasoline. (Use of leaded gasoline will increase carbon and lead oxide deposits and reduce valve life). Capacity is 3-1/2 gallons.
- c. Place attachment clutch switch in "DISENGAGED" position.
- d. Push clutch/brake pedal fully into brake position.
- e. Place gear shift lever in "N" neutral, start position (Fig. 14).
- f. Place range shift lever in "N" neutral position (Fig. 14).
- g. Pull choke out (Fig. 14).
- h. Move throttle control to middle position (Fig. 14).
- i. Turn ignition to "START" position until engine starts (Fig. 14). NOTE: DO NOT RUN STARTER CONTINUOUSLY FOR MORE THAN FIFTEEN SECONDS PER MINUTE. If engine does not start after several attempts, move throttle control to "F" (fast) position, wait a few minutes and try again.
- j. After engine is warm, push choke in.

The first time you start the engine, it will take extra cranking time to move fuel from tank to engine. NOTE: ALLOW ENGINE TO WARM UP FOR A FEW MINUTES BEFORE ENGAGING CLUTCH/BRAKE PEDAL OR ATTACHMENT CLUTCH SWITCH.

- k. When restarting a warm engine, move throttle control midway between "S" (slow) and "F" (fast) position. Choke may not have to be used.



**BEFORE DRIVING THE TRACTOR, INSTALL MOWER OR REMOVE FRONT MOWER SUSPENSION BRACKET AND SUSPENSION ARMS.(FIG.8)**



## TO AVOID INJURY

1. Read owner's manual.
2. Know location and function of all controls
3. Keep guards, safety shield and switches in place and working.
4. Remove objects that can be thrown by blades.
5. Do not mow when children and others are around.
6. Never carry children or passengers.
7. Always look behind machine before backing
8. Do not mow where machine can tip or slip.
9. If machine stops going uphill, stop blades and back slowly down.
10. Be sure blades and engine have stopped before placing hands or feet near the blades.
11. Remove key when leaving machine.



**NEVER PLACE YOUR HANDS OR FEET IN OR UNDER ANY POWERED ATTACHMENT OR NEAR ANY MOVING PART WHILE TRACTOR OR ANY POWERED ATTACHMENT IS RUNNING.**

**DO NOT OPERATE THE MOWER WITHOUT THE DEFLECTOR SHIELD IN PLACE.**



**DO NOT OPERATE THE MOWER WITHOUT EITHER THE ENTIRE GRASS CATCHER, ON UNITS SO EQUIPPED, OR THE DEFLECTOR GUARD IN PLACE.**

**CAUTION : DO NOT ADD ADDITIONAL WEIGHT TO THE TRACTOR OTHER THAN THE OPTIONAL WHEEL WEIGHTS. EXCESSIVE WEIGHT MAY OVERLOAD AND DAMAGE THE TRANSMISSION.**

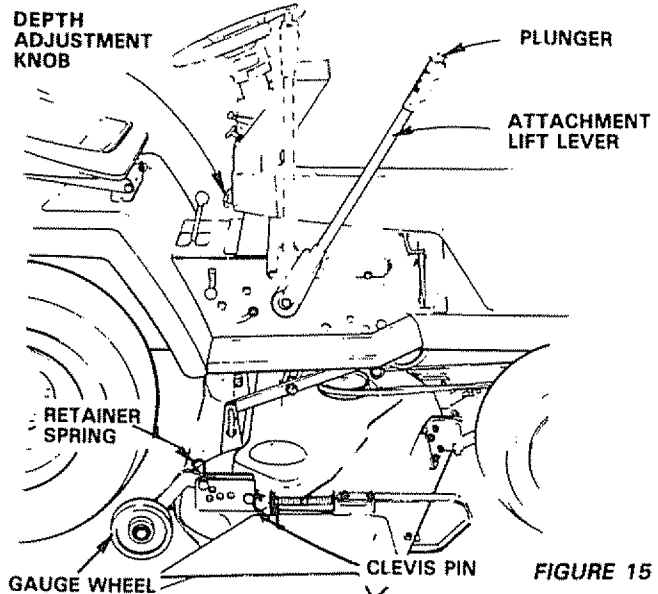

FIGURE 15

## 3. Operating Your Tractor and Mower

NOTE: THIS TRACTOR IS EQUIPPED WITH AN OPERATOR PRESENCE SENSING SWITCH. ANY ATTEMPT BY THE OPERATOR TO LEAVE THE SEAT WITH THE ENGINE RUNNING AND THE ATTACHMENT CLUTCH ENGAGED WILL SHUT OFF THE ENGINE.



**READ THE "SAFETY RULES" CAREFULLY BEFORE OPERATING YOUR MOWER.**

Use the height adjustment knob (Fig. 14) to adjust mower height. With the attachment lift lever in the full "UP" position, turn height adjustment knob clockwise (↻) to raise cutting height and counterclockwise (↺) to lower cutting height. Lower attachment lift lever to check adjustment.

- a. To adjust gauge wheels (Fig. 15) lower attachment lift lever.
- b. Remove retainer spring and clevis pin from gauge wheels.
- c. Move gauge wheels to the adjustment hole that will provide the desired cut.
- d. Replace retainer spring and clevis pin.
- e. Move attachment lift lever to its full "UP" position.
- f. With engine running and warm, place throttle control midway between "S" (slow) and "F" (fast) position (Fig. 14).
- g. To engage mower pull attachment clutch switch (Fig. 14) out and up.

# OPERATION



FUNCTION	GEARSHIFT	THROTTLE
Normal Mowing	2H* or 3L*	
Heavy Mowing	1H or 2L	
Snow Removal	1L	
Tilling Plowing	1L	MID THROTTLE
Dozing	1L	
Grading	2L	
Transport	3H	

FIGURE 16

\* Indicates Range Shift Lever position: "H" for High, "L" for low

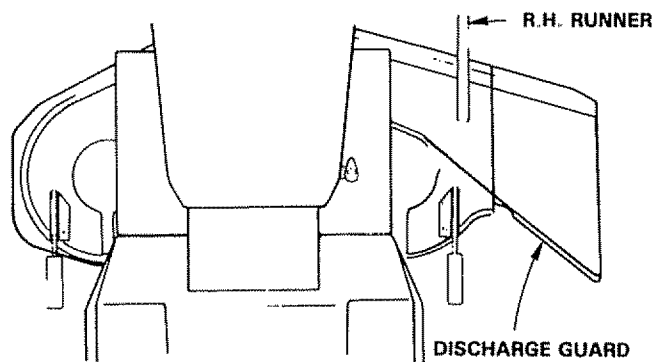

FIGURE 17

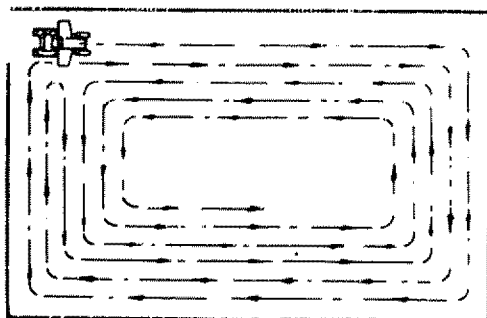

FIGURE 18

- h. Move range shift lever to "LO" (low) position (Fig. 14).
- i. Move gear shift lever to desired gear (Fig. 14).
- j. Use attachment lift lever to lower mower into cutting position.
- k. Release clutch/brake pedal SLOWLY to start movement.
- l. Start mowing at slow and increase ground speed by increasing throttle as conditions will permit.

NOTE: BRING TRACTOR TO COMPLETE STOP BEFORE SHIFTING GEARS.

#### 4. Mowing Tips

NOTE: TIRE CHAINS CANNOT BE USED WITH THE MOWER HOUSING ATTACHED



**READ THE "SAFETY RULES" CAREFULLY BEFORE OPERATING YOUR MOWER. REFER TO PAGE 2.**

- a. Use the runner on the R.H. side as a guide; the blade cuts approximately an inch outside the runner (Fig. 17).
- b. Drive so that clippings are discharged onto the area that has been cut. Have the cut area to the right of the machine. This will result in a more even distribution of clippings and more uniform cutting.
- c. When mowing large areas (Fig. 18), start by turning to the right so that the clippings will be discharged away from shrubs, fences, driveways, etc. After two or three rounds, mow in the opposite direction making left hand turns until finished.
- d. If grass is extremely tall, it should be mowed twice. The first time cut relatively high. The second time to the desired height.
- e. The left hand side of mower should be used for trimming.
- f. Do not mow tall, dry grass over 6 inches tall. It is a fire hazard

#### 5. Operating The Tractor On Hills

- a. Choose the lowest gear BEFORE starting up or down hills.



**DO NOT DRIVE UP OR DOWN HILLS WITH SLOPES GREATER THAN 15° AND DO NOT DRIVE ACROSS ANY SLOPE. REFER TO PAGE 51.**

- b. Avoid stopping or shifting on hills.
- c. If slowing is necessary, move throttle control lever to middle position.



**LEAVE ENOUGH ROOM WHEN STOPPING AND STARTING TO ALLOW SLIGHT TRACTOR ROLL DOWNHILL AS CLUTCH/BRAKE PEDAL MOVES THROUGH CLUTCH POSITION.**

- d. If stopping is absolutely necessary, push clutch/brake pedal quickly to brake position and engage parking brake.

e. To restart your tractor, make sure tractor is in 1st gear and that you have allowed room to roll slightly downhill. Disengage parking brake and release clutch/brake pedal SLOWLY to start tractor forward movement.

f. Make all turns slowly.

**To keep your tractor running better, longer, perform necessary service using the following maintenance schedule:**



**BEFORE MAKING ANY INSPECTION, ADJUSTMENT OR REPAIR: (FIG. 19):**

1. PUSH TRACTOR CLUTCH/BRAKE PEDAL COMPLETELY INTO BRAKE POSITION.
2. MOVE GEAR SHIFT CONTROL LEVER TO NEUTRAL POSITION.
3. PLACE PARKING BRAKE IN "ENGAGED" POSITION AND REMOVE FOOT FROM PEDAL.
4. TURN OFF ATTACHMENT CLUTCH SWITCH.
5. SHUT OFF THE ENGINE.
6. MAKE ABSOLUTELY SURE THE BLADES AND ALL MOVING PARTS HAVE COMPLETELY STOPPED.
7. DISCONNECT THE SPARK PLUG WIRES FROM THE SPARK PLUGS AND KEEP WIRES AWAY FROM THE SPARK PLUGS TO PREVENT INJURY FROM ACCIDENTAL STARTING. BE CAREFUL TO AVOID TOUCHING HOT ENGINE OR MUFFLER COMPONENTS.

### With Every Mowing

1. Make sure all nuts on bolts are tight and cotter pins and retainer springs are secure.
2. Observe all safety precautions.
3. Keep tractor well lubricated (refer to page 18).

### First 2 Hours (Two Mowings)

#### 1. Change Engine Oil

Changing oil after the first two hours (or two mowings) will help eliminate break-in residue which might be damaging to your engine.

NOTE: BE CAREFUL NOT TO ALLOW DIRT TO ENTER THE ENGINE WHEN CHANGING OIL.

- a. Drain oil with engine warm.
  - b. Remove hood and grill (see page 23).
  - c. Loosen oil drain wing nut (Fig. 20 - Inset). Catch oil in a suitable container.
  - d. Tighten oil drain wing nut after all oil has been removed from engine.
  - e. Refill engine oil. Refill capacity is 3 pints.
- NOTE: DO NOT OVERFILL.
- f. Replace dipstick.

# MAINTENANCE

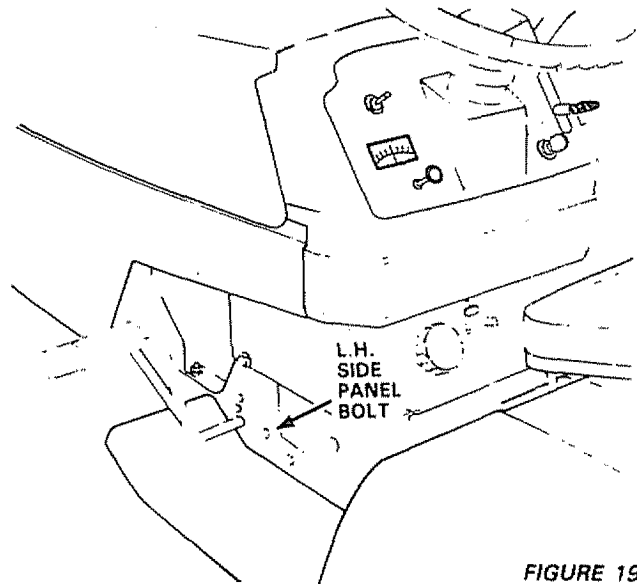
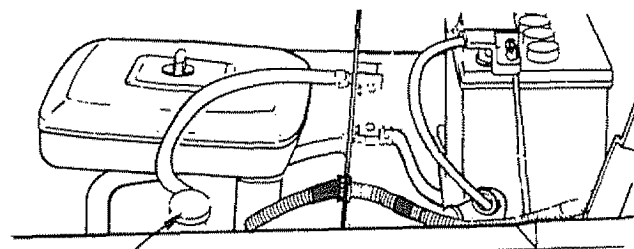

FIGURE 19



ENGINE OIL  
DIPSTICK  
AND FILL TUBE

L H SIDE

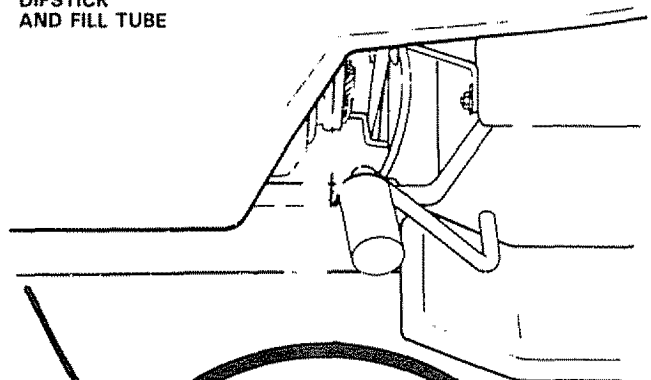
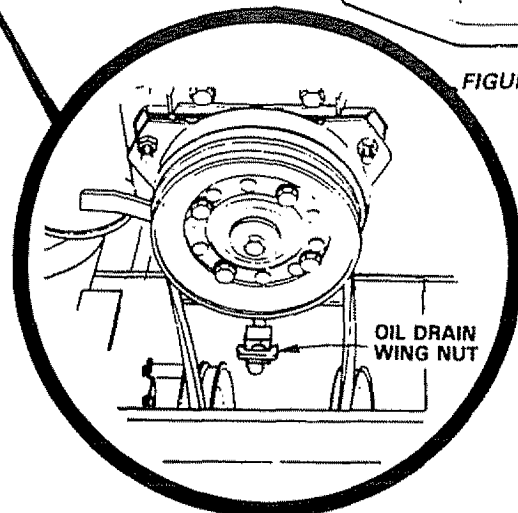

FIGURE 20



# MAINTENANCE

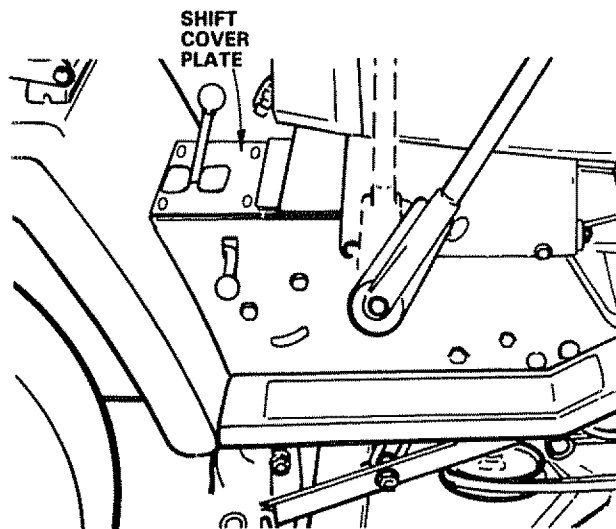

FIGURE 21

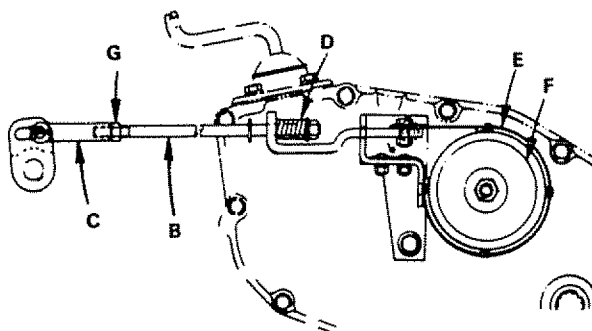

FIGURE 22

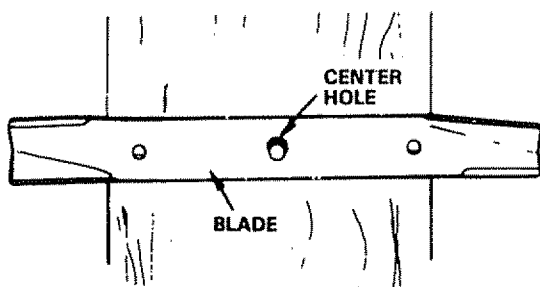
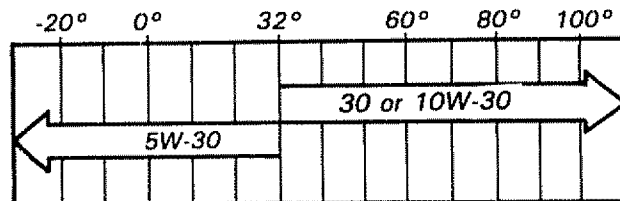

FIGURE 23

## Recommended SAE Viscosity Grades

Determine temperature expected before next oil change. All oil must meet A.P.I. service classification SD, SE or SF.



Capacity is 3 pints. NOTE: DO NOT OVERFILL. Dipstick assembly must be securely tightened into tube at all times when engine is operating.

CAUTION: TO AVOID DAMAGE TO THE STARTING SYSTEM, USE SAE 5W30 OIL WHEN THE TEMPERATURE FALLS BELOW 32°.

## Every 5 Hours (Five Mowings)

### 1. Check Engine Oil Level

NOTE: DO NOT CHECK ENGINE OIL LEVEL WITH ENGINE RUNNING.

Several minutes after stopping engine, check engine oil level with tractor on level ground. Wipe dipstick (Fig. 20) clean, screw it down tight for a few seconds, remove and read oil level. If necessary, add oil until "FULL" mark is reached. NOTE: DO NOT OVERFILL.

## Every 25 Hours (Twice a Mowing Season)

(Operating in dusty conditions may require more frequent servicing.)

### 1. Brake Adjustment



IF TRACTOR REQUIRES MORE THAN SIX FEET STOPPING DISTANCE IN HIGHEST GEAR ON A LEVEL DRY CONCRETE OR PAVED SURFACE THEN BRAKE MUST BE ADJUSTED.

- Remove (4) hex washer head tapping screws from shift cover plate (Fig. 21), located on top of tractor frame. Remove the cover plate.
- Loosen jam nut (G) on brake rod (B) at clevis (C) (Fig. 22). If you find it difficult to loosen jam nut (G), remove cover plate in L.H. frame rail.
- Rotate brake rod (B) counterclockwise (↺) turning brake rod out of clevis (C) four to six turns.
- Start tractor with transmission in "N" (neutral) position.
- Depress clutch/brake pedal to the point where belt stops moving.

- f. Engage parking brake to hold clutch/brake pedal in position. If belt begins to move after engaging parking brake, depress clutch/brake pedal to next notch on parking brake.
- g. Shut engine off. Rotate brake rod (B) clockwise (↻) by hand, turning brake rod into clevis (C), until tight. Tighten jam nut (G) on brake rod. (B) at clevis (C) (Fig. 22).
- h. Reinstall shift cover plate and four (4) mounting screws. Replace cover plate if removed in step b.

## 2. Tire Care

Maintain tire pressure in front at 14 PSI and rear tires at 10 PSI.

## 3. Blade Care

For best results mower blades must be kept sharp. The blades can be sharpened with a few strokes of a file or on a grinding wheel. We suggest they be sharpened after every 24 hours of mowing. Do not attempt to sharpen while on mower. If you mow in sandy soil check the blades after each two mowings. The sand wears the blades away rapidly.

- a. When grinding, care should be taken to maintain blade balance and the blade should be checked for proper balance before reinstallation on mower.
- b. Unbalanced or bent blade will cause excessive vibration when running and eventual damage to mower or engine. Replace bent or damaged blades.

To check blade balance, drive a nail into a beam or wall. Leave about one inch of the straight nail exposed. Place center hole of clean blade over the head of the nail (Fig. 23). NOTE: CENTER HOLE OF BLADE ON NAIL. IF BLADE IS PROPERLY BALANCED, BLADE SHOULD REMAIN IN POSITION SHOWN IN FIG. 23. IF EITHER END OF THE BLADE MOVES DOWNWARD, BLADE IS NOT BALANCED, SHARPEN THE HEAVY END UNTIL THE BLADE IS BALANCED.

## Every 50 Hours (Once a Mowing Season)

(Operating in dusty conditions may require more frequent servicing)

### 1. Check Battery

- a. Battery acid solution level in each battery cell should be even with bottoms of tubes in cells (Fig. 24). Add only distilled water if necessary. NOTE: DO NOT OVERFILL. DO NOT ADD ACID.
- b. Keep battery and terminals clean. Refer to page 18.
- c. Keep battery bolts tight.
- d. Keep vent caps tight and small vent holes in caps open.

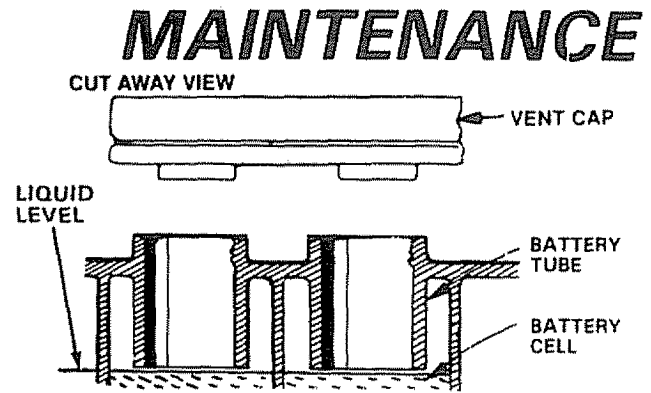

FIGURE 24

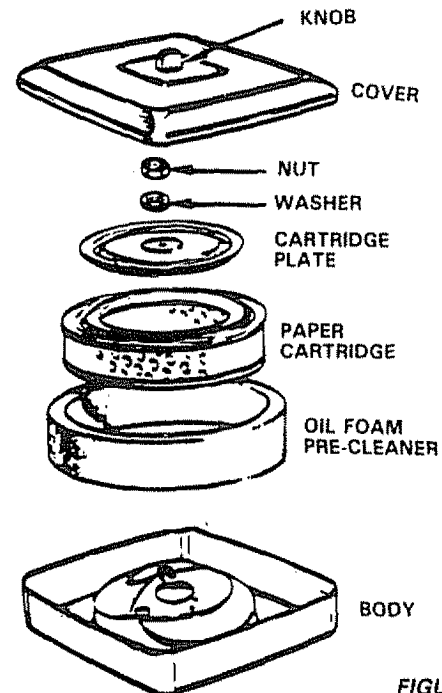

FIGURE 25

### 2. Clean Air Filter

- a. Unscrew knob (Fig. 25) to remove cover.
- b. Remove nut and washer to remove cartridge plate, paper cartridge and oil foam pre-cleaner.
- c. Wash foam pre-cleaner in detergent and water.
- d. Rinse, squeeze (rather than twist) allow to dry thoroughly.
- e. Lightly coat with S A E 30 engine oil. Do not saturate. Squeeze in a rag or towel to distribute evenly and remove excess.
- f. Check paper cartridge. Replace if excessively dirty.
- g. Reassemble paper cartridge and re-position on tractor. NOTE: NEVER RUN ENGINE WITH AIR FILTER REMOVED AS DIRT (DUST) WILL DAMAGE THE ENGINE.

# MAINTENANCE

## 3. Clean Battery and Terminals

Corrosion and dirt on the battery and terminals cause the battery to "leak" power and hinders the operation of the charger.

- a. Remove terminal guard.
- b. Remove the battery from the tractor and wash with four tablespoons of baking soda to one gallon of water. NOTE: BE CAREFUL NOT TO GET THE SODA SOLUTION INTO THE CELLS.
- c. Clean terminals and cable ends with a wire brush until bright.
- d. Rinse the battery with plain water, dry and reinstall on tractor.
- e. Replace cables and terminal guard. Refer to page 8.

## 4. Change Engine Oil

The best time to drain engine oil is at the end of a day's operation when all dirt and foreign materials are suspended in the hot oil. Refer to page 15.

## 5. Lubricate Pivot Points

Place several drops of S.A.E. 30 oil at points where parts move against each other, especially:

- a. Front Axle Pivot
- b. Hood Hinges
- c. Foot Pedal Shaft (both ends)
- d. Lift Shaft (both ends)
- e. Sector gear pivot points

## Lubrication Chart

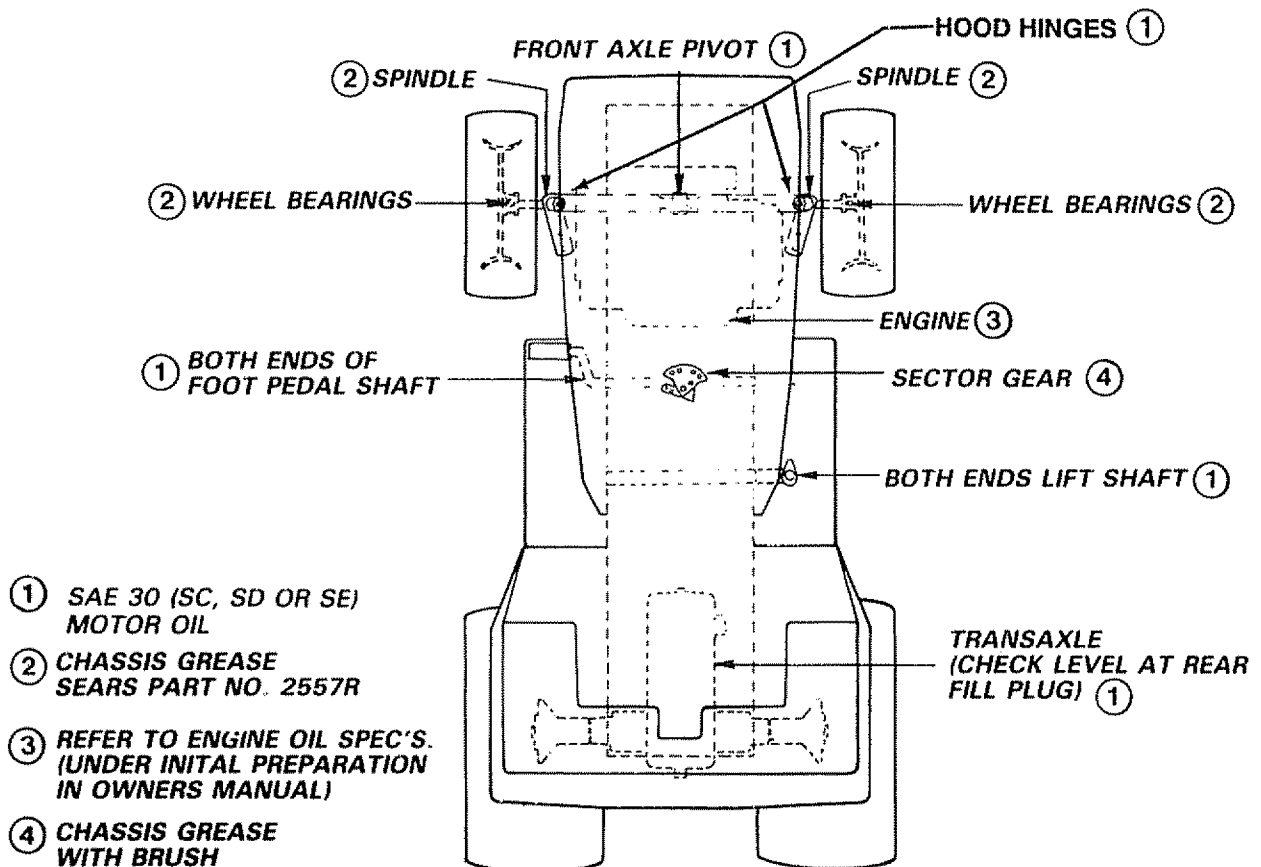

# MAINTENANCE

## 6. Clean Air Screen

Air screen (Fig. 26) must allow free-flow of air to prevent engine damage from overheating. Clean with a wire brush or compressed air to remove dirt, stubborn dried gum and fibers.

## 7. Clean Front Grill

Brush debris from front grill to allow free-flow of air, preventing engine damage from overheating.

## 8. Lubricate Steering and Front Wheels

There are four grease fittings on your tractor (Fig. 27). Using a grease gun, give each grease fitting two shots of chassis grease (available through your Sears Service Center). Sears Part No. 2557R.

## 9. Check Muffler

Inspect and replace corroded muffler as it could create a fire hazard and/or engine damage.

## EVERY 100 HOURS (Every Two Years)



**DISCONNECT SPARK PLUG WIRES TO PREVENT ACCIDENTAL STARTING BEFORE MAKING ANY INSPECTION, ADJUSTMENT OR REPAIR (EXCEPT CARBURETOR).**

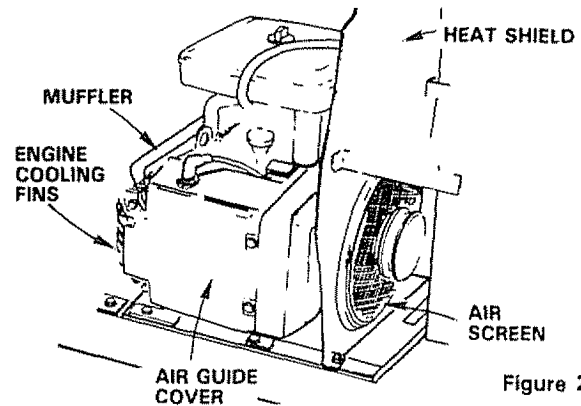

Figure 26

## 1. Replace Spark Plugs

Replace spark plugs at the beginning of each season or every 100 hours, whichever comes first. Gap should be set at 0.030 inch (Fig. 28). Refer to Page 45 for replacement information.

## 2. Replace Air Filter Paper Cartridge

Refer to page 17.

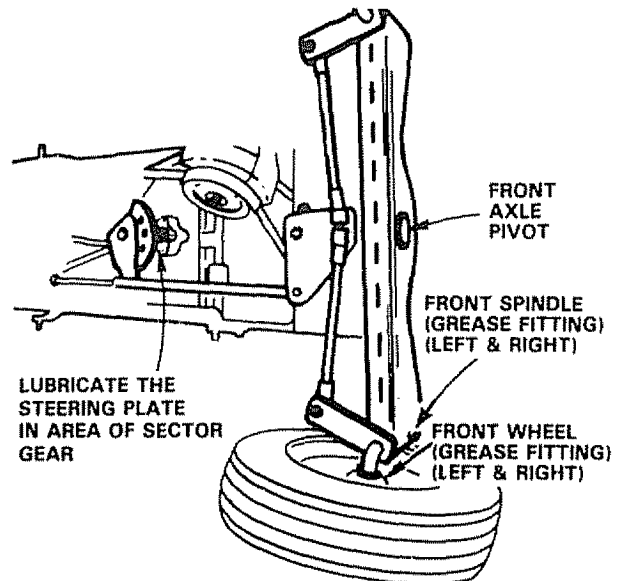

FIGURE 27

# REPAIR AND ADJUSTMENT

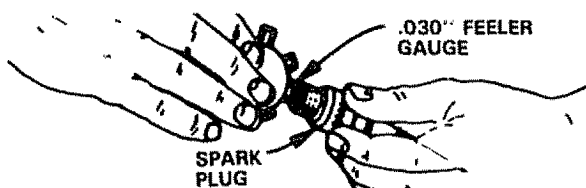

FIGURE 28

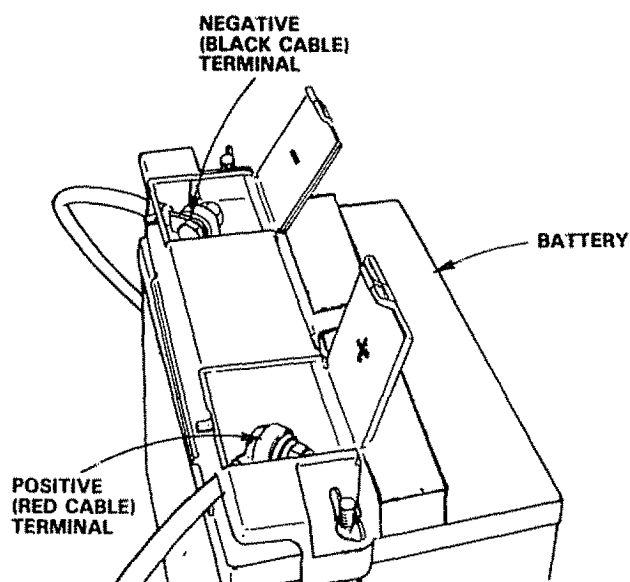

FIGURE 29

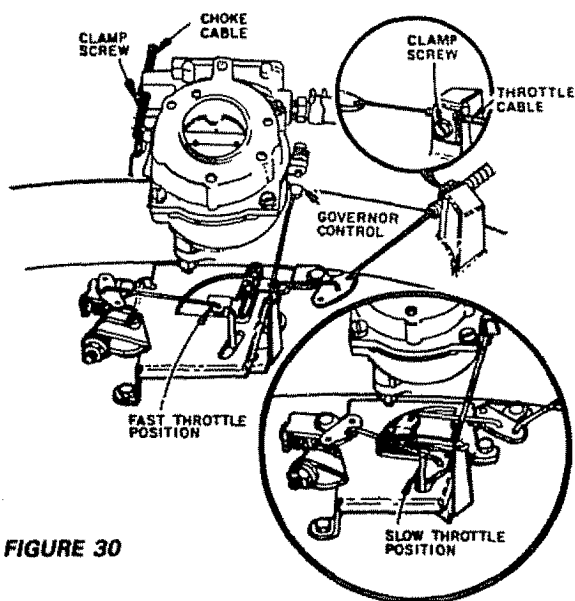

FIGURE 30

## 1. Starting Your Tractor with a Weak Battery

If your battery is too low to start the engine, it should be recharged. If "jumper cables" are used for emergency starting follow this procedure:

NOTE: YOUR TRACTOR IS EQUIPPED WITH A 12 VOLT NEGATIVE GROUNDED SYSTEM, THE OTHER VEHICLE MUST ALSO BE A 12 VOLT NEGATIVE GROUNDED SYSTEM.

**LEAD-ACID BATTERIES GENERATE EXPLOSIVE GASES. KEEP SPARKS, FLAME AND SMOKING MATERIALS AWAY FROM BATTERIES. ALWAYS WEAR EYE PROTECTION AROUND BATTERY.**

- Connect each end of the RED cable to the POSITIVE (+) terminals of each battery (taking care not to short against chassis). (Fig. 29).
- Connect one end of the BLACK cable to the NEGATIVE (-) terminal of fully charged battery.
- Connect the other end of the cable to L.H. side panel bolt (Fig. 19). NOTE: KEEP AWAY FROM GAS TANK AND BATTERY.
- Disconnect cables in reverse order:
  - L.H. Side Panel Bolt (Fig. 19).
  - Negative Terminal of fully charged Battery
  - Positive Terminals

**CAUTION: DO NOT USE YOUR BATTERY TO START OTHER VEHICLES.**

## 2. THROTTLE CONTROL CABLE ADJUSTMENTS

Never attempt to change maximum engine speed. This is preset at the factory (3400 ± 100 RPM) and should only be change by a qualified service technician who has the necessary equipment

- Remove hood, page 23
- Loosen casing clamp screw until throttle cable is free to move (Fig. 30).
- Move throttle control (on the dash board) to "Fast" position
- Pull throttle cable tight (until swivel is against side of quarter circle) Fig 30 Retighten casing clamp screw

**REFER TO "STARTING THE ENGINE", PAGE 12.**

## 3. CARBURETOR ADJUSTMENT

NOTE: Adjust throttle control cable before making any adjustment to carburetor. Air cleaner must be assembled to carburetor when running engine

Minor carburetor adjustments may be required to compensate for differences in fuel, temperature or altitude. Adjust the carburetor fuel mixture as follows:

- Gently turn idle mixture valve clockwise (↻) Fig. 31 until it just closes and then counterclockwise (↺) 1 1/2 turns  
CAUTION: Valve may be damaged if turned in too far
- Start engine and allow to warm for five minutes. Make final adjustments with engine running and choke pushed in.

# REPAIR AND ADJUSTMENT

- c. Move throttle control lever (on dashboard) to slow position
- d. Hold governor control lever against idle speed screw and adjust idle speed screw to obtain 1200 to 1400 RPM Fig. 31
- e. While still holding the governor control lever against idle speed screw, turn idle mixture valve slowly clockwise (↻) (lean mixture) until speed just starts to slow. Then turn counterclockwise (↺) (rich mixture) until engine begins to run rough.
- f. Turn idle mixture valve back to the midpoint between rich and lean.
- g. Adjust the idle speed screw to obtain 900 to 1200 RPM. Release governor control lever.
- h. Move throttle control (on the dashboard) to "FAST". If engine hesitates or dies, turn idle mixture valve approximately 1/8 turn counterclockwise (↺) until engine will accelerate as throttle control is moved from "SLOW" to "FAST".

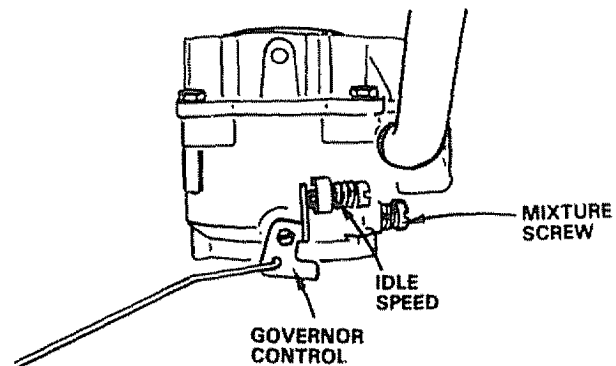

FIGURE 31

## 4. Electric Clutch Adjustment

The electric clutch (Fig. 32) should provide years of service. The clutch incorporates a built-in brake that stops the pulley almost immediately. Eventually, the internal brake will wear so the mower blades will not stop as recommended. Adjustment must be made by a Sears Service Technician.

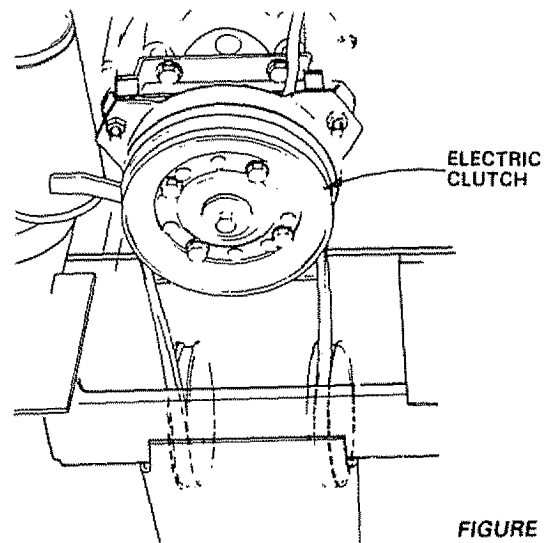

FIGURE 32

## 5. Motion Drive Belt Removal

The belt on this tractor is special for this application. Always replace with the Sears belt number in the parts list. It is not necessary to remove mower.

- a. Raise hood and disconnect negative ground battery cable.
- b. Set parking brake (to get belt slack).
- c. Loosen (do not remove) two engine pulley belt guide bolts and swivel R.H. side of belt guide up. Tighten L.H. bolt to hold belt guide in position (Fig. 33).
- d. Roll belt off engine pulley.
- e. Roll belt off "V" idler, flat idler and adjustable idler pulleys (Fig. 34).
- f. Pull belt off clutch pulley - between pulley and frame.

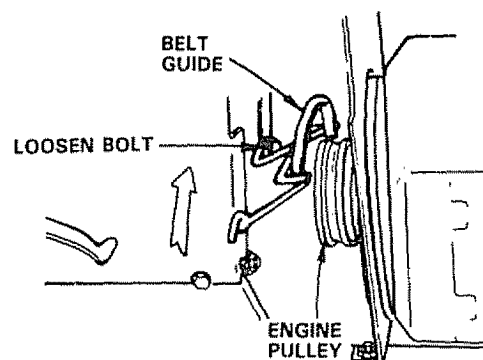

FIGURE 33

## 6. Motion Drive Belt Replacement

NOTE: THERE IS A BELT INSTALLATION DECAL UNDER L.H. FOOTREST.

- a. Push belt down from engine pulley area. Place back (flat) side of belt on flat idler. (Flat idler is next to frame).
- b. Place belt on adjustable idler and over clutch pulley. "V" (narrow) part of belt should engage clutch pulley.

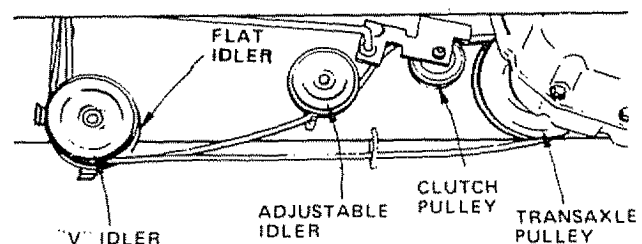

FIGURE 34

# REPAIR AND ADJUSTMENT

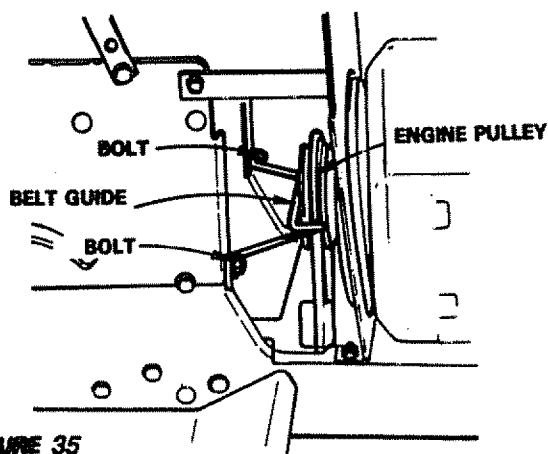

FIGURE 35

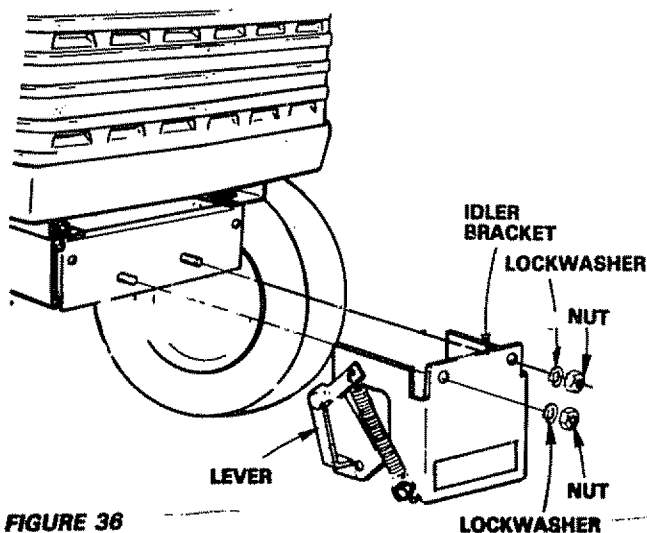

FIGURE 36

- c. Place belt around transaxle pulley. "V" part of belt should engage transaxle pulley.
- d. Make sure "V" part of belt engages "V" idler.
- e. Roll belt over engine pulley.
- f. Loosen L.H. engine pulley belt guide bolt and swivel belt guide bolt and swivel belt guide on-to R.H. bolt. Tighten L.H. and R.H. bolts securely (Fig. 35).
- g. Release parking brake. NOTE: WHEN A NEW BELT HAS BEEN INSTALLED, YOU MUST CHECK BRAKE ADJUSTMENT.

## 7. Idler Bracket Removal

NOTE: WHEN OPERATING TRACTOR WITHOUT MOWER, REMOVE IDLER BRACKET FROM FRONT OF TRACTOR.

- a. Pull belt up through idler bracket and out of tractor. Use lever to swing tension pulley for belt removal.
- b. Remove lockwashers and nuts from idler bracket (Fig. 36).

# REPAIR AND ADJUSTMENT

## 8. Fuse Replacement

Fuse is located under dash to the left of the battery. If fuse replacement is necessary, replace with 30 amp automotive - type plug-in fuse. Fuses can be purchased at all Sears Service Centers and most retail stores.

## 9. Check Transaxle Oil Level

- Block up rear axle (Fig. 37) securely or use a tractor jack.
- Remove left rear wheel by removing hub bolts.
- Remove filler plug (Fig. 37) from transaxle. Oil level must be even with plug threads. See your Sears Service Center if additional oil is required. Replace filler plug.
- Reposition wheel. Secure with hub bolts.

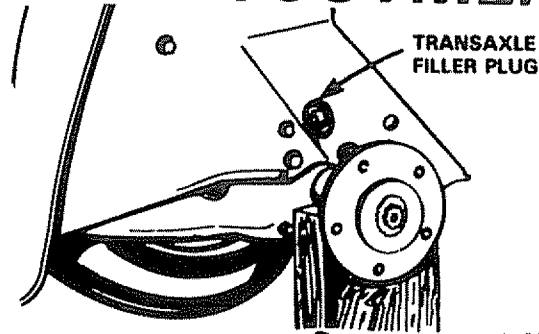

FIGURE 37

## 10. Hood Removal

- Lift hood. Disconnect headlight wiring connection (Fig. 38).
- Unscrew one screw at rear of each side panel (Fig. 38).
- Pivot hood and side panel forward and lift off tractor (Fig. 39).
- To replace, reverse the above procedure.

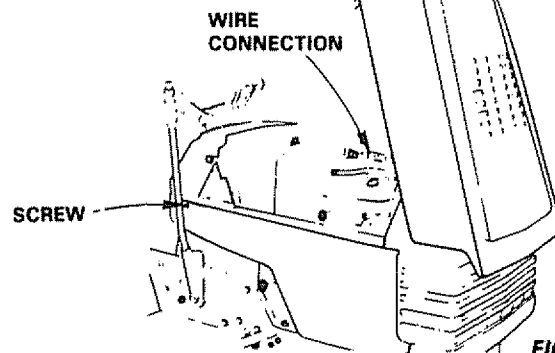

FIGURE 38

## 11. Mower Removal

- Lower mower.
- Pull the four (4) release pins out of suspension brackets (Fig. 40).
- Pull back on attachment lift lever and lock into place.
- Slide mower forward and remove belt from primary mandrel.
- Slide mower out from under tractor.

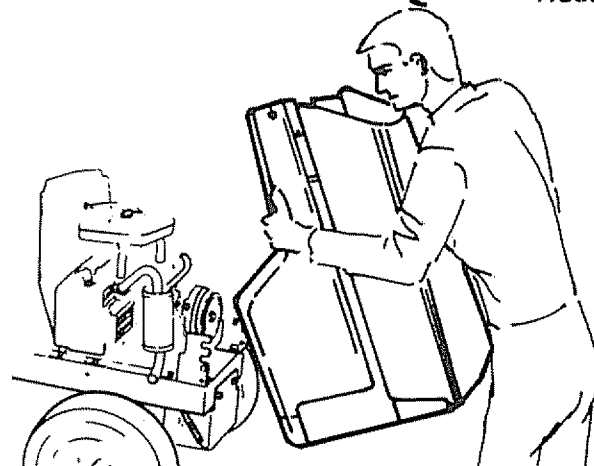

FIGURE 39

NOTE: IF AN ATTACHMENT OTHER THAN THE MOWER DECK IS TO BE MOUNTED ON THE TRACTOR, REMOVE THE L.H. AND R.H. SUSPENSION ARMS AND THE FRONT SUSPENSION BRACKET. (FIG. 40)

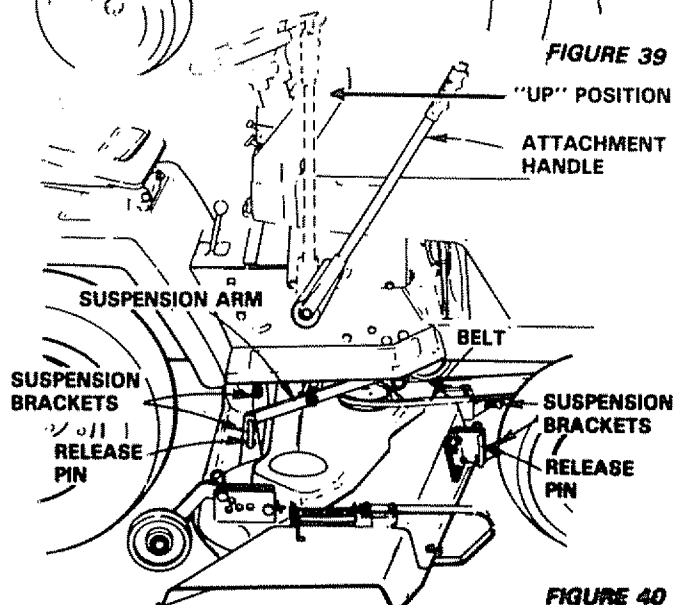

FIGURE 40

# REPAIR AND ADJUSTMENT

## 12. Level Mower Housing

Adjust the mower while tractor is parked on level ground or driveway. Make sure tire pressures are 14 PSI in front; 10 PSI in rear.

### Side to Side Mower Adjustment

- Move attachment lift lever to full "UP" position (Fig. 44).
- Use a ruler to make sure bottom of curl at rear of mower deck is the same height from the ground on each side (Fig. 42).
- If adjustment is required, snap out access cover on L.H. side of tractor above footrest (Fig. 41).
- To raise left side of mower, loosen nut "B" and screw nut "A" down on adjustment rod.
- Adjust until both rear mower flanges are the same height above the ground. Tighten nuts "A" and "B" securely.
- Snap access cover in place.

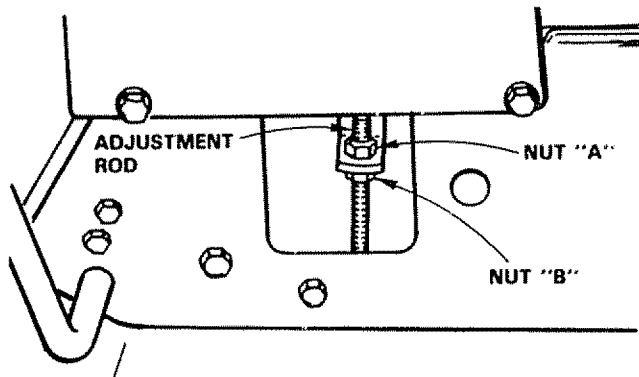

FIGURE 41

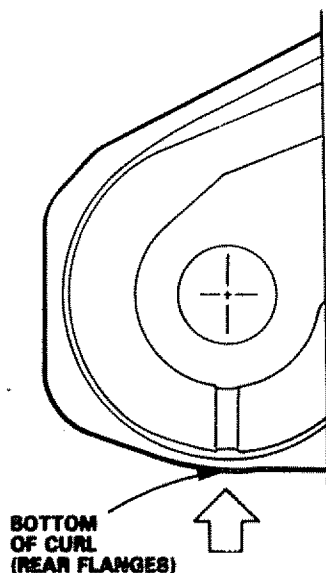
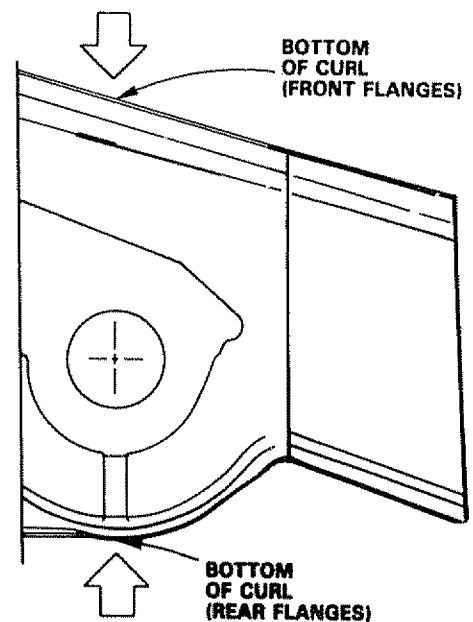

FIGURE 42

### Front to Rear Mower Adjustment

Move attachment lift lever to full "UP" position. After leveling side to side, measure Bottom of Curl at FRONT AND REAR OF MOWER. The bottom of curl at the R.H. front flanges should measure 3/4" lower than at the R.H. REAR flange (Fig. 42). If adjustment is required follow the procedure below.

- To raise front of mower loosen nuts "D". Screw nuts "C" up onto suspension arms (Fig. 43). NOTE: SCREW NUTS "C" ON BOTH SUSPENSION ARMS THE SAME NUMBER OF TURNS SO MOWER WILL REMAIN LEVEL. Tighten nuts "D" securely.
- To lower front of mower loosen nuts "C". Screw nuts "D" down suspension arms. NOTE: SCREW NUTS "D" THE SAME NUMBER OF TURNS SO MOWER WILL REMAIN LEVEL. Tighten nuts "C" securely.
- With mower deck at desired height, set gauge wheels (Fig. 44) to lowest position without touching the ground.
- Use attachment lift lever to set mower at the approximate cutting height you need.
- Use clevis pin (Fig. 44) to set gauge wheels at lowest point without touching the ground.



# REPAIR AND ADJUSTMENT

## 13. Blade Drive Belt Removal and Replacement

BELT ROUTING DECAL UNDER MOWER DECK COVER.

- a. Remove mower from tractor (see page 23).
- b. Remove top cover self tapping screws, lockwashers and nuts from idler arm bolt.
- c. Roll belt over the top of the R.H. mandrel.
- d. Pull belt off all other mandrels.
- e. Remove any dirt and grass which may have accumulated around mandrels and idler arm.
- f. Check deck idler arm assembly and flat idler to see that they rotate freely (Fig. 45).
- g. Be sure spring is hooked in deck idler arm assembly and on bolt in mower housing (Fig. 45).
- h. Install new belt in groove of L.H. mandrel sheave, lower groove of center mandrel sheave and around flat idler as shown (Fig. 45).
- i. From a position at discharge end of mower, roll belt into groove of R.H. mandrel sheave (Fig. 45).
- j. Rotate center mandrel sheave by hand to make sure belt is in grooves properly.



**BLADES WILL ROTATE WITH CENTER MANDREL SHEAVES.**

- k. Reassemble top cover to deck. Tighten all screws securely.
- l. Install mower to tractor (see page 10).

## 14. Attachment Lift Spring Adjustment

Due to different weights of attachments, the attachment lift spring may require adjustment. The adjustment bolt is located on rear of tractor top left side (Fig. 46).

- a. Holding spring bushing with wrench, loosen jam nuts.
- b. Turn adjustment bolt clockwise (↻) to extend spring and reduce lift effort (for heavier attachments).
- c. Turn adjustment bolt counterclockwise (↺) (for lighter attachments).
- d. Retighten jam nut against spring bushing.

NOTE: DO NOT ADJUST FOR MAXIMUM SPRING TENSION WHEN USING LIGHT ATTACHMENTS SUCH AS A MOWER. ADJUST LIFT LEVER SPRING TO AID IN LIFTING ATTACHMENT. DO NOT OVER POWER SPRING. WHEN REMOVING ATTACHMENT, ALWAYS ADJUST WITH SPRING TENSION TO ITS LOWEST POSITION.

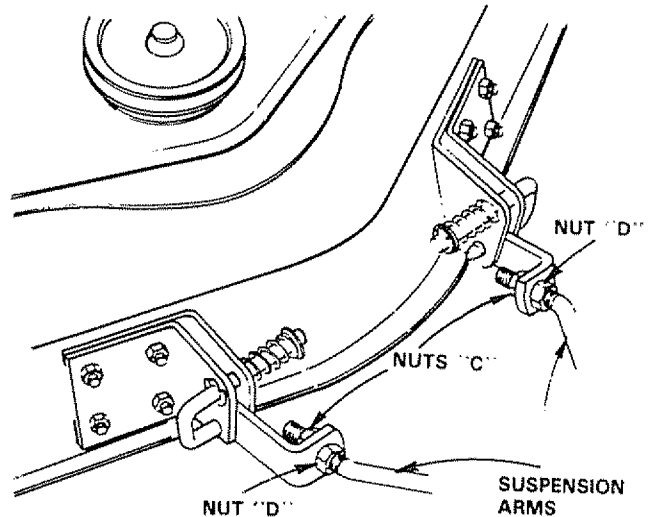

FIGURE 43

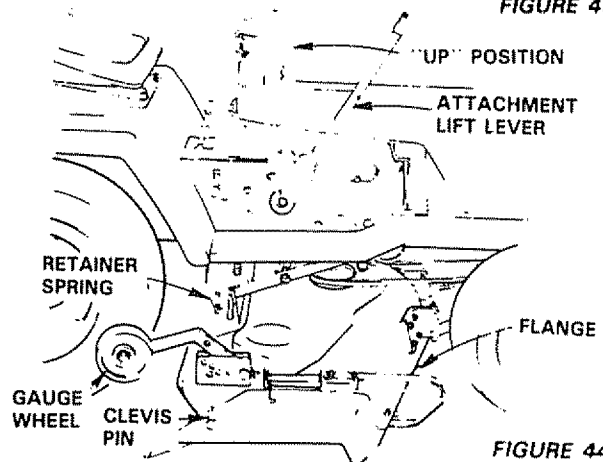

FIGURE 44

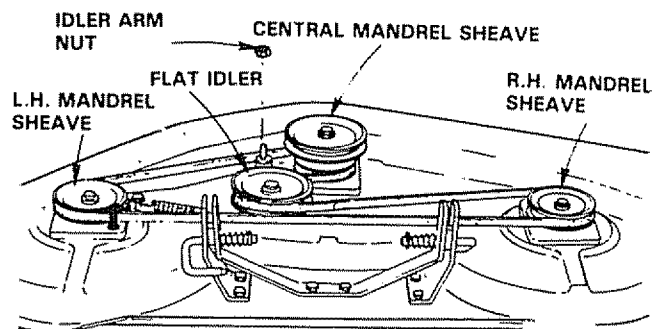

FIGURE 45

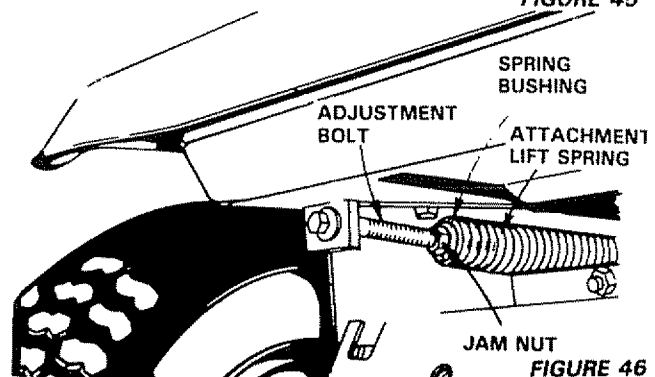

FIGURE 46

# REPAIR AND ADJUSTMENT

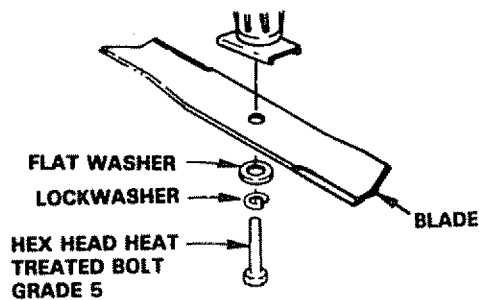

FIGURE 47

## 15. Blade Replacement

It is not necessary to remove mower from tractor for blade replacement. Moving adjustment lift lever to up (Rear) position will permit access to blades.

- Remove the hex head bolt, lockwasher and flat washer (Fig. 47).
- Remove and discard old blade.
- Clean top and bottom of mower housing.
- Install new blade with SHARP EDGE DOWN and secure with flat washer, lockwasher and hex head bolt. **TIGHTEN SECURELY.**



**ALWAYS USE GRADE 5 HEAT TREATED BOLTS TO ATTACH BLADES. CHECK BOLTS IN BLADES OCCASIONALLY TO MAKE SURE BOLTS ARE TIGHT. TORQUE BOLTS 30 - 35 FT. LBS.**

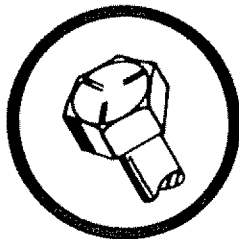

**A GRADE 5 HEAT TREATED BOLT CAN BE IDENTIFIED BY THREE LINES ON THE BOLT HEAD AS SHOWN ON LEFT.**

## 16. Storage

Remove mower from tractor for winter storage. When mower is to be stored for a period of time, clean it thoroughly, remove all dirt, grease, leaves, etc. Store in a clean dry area.

## A. Fuel System

It is important to prevent gum deposits from forming in essential fuel system parts such as the carburetor, fuel filter, fuel hose, or tank during storage. Also, experience indicates that alcohol blended fuels (called gasohol or using ethanol or methanol) can attract moisture which leads to separation and formation of acids during storage. Acidic gas can damage the fuel system of an engine while in storage. To avoid engine problems, the fuel system should be emptied before storage of 30 days or longer.

## B. Engine Oil

Drain (with engine warm) and replace with clean engine oil, ( Refer to page 16).

## C. Cylinders

- Remove spark plugs.
- Pour one ounce of oil through spark plug holes into cylinders.
- Turn ignition key to "START" position for a few seconds to distribute oil.
- Replace with new Spark Plugs. Refer to Page 45 for replacement information.

## D. Battery

- Remove battery if tractor is not used regularly during winter months. Store in cool, dry place (above 50°F).
- Re-charge each month if necessary. **NOTE: BATTERIES NOT IN USE FOR SEVERAL MONTHS AND NOT KEPT FULLY CHARGED, PRODUCE SULFATE DEPOSITS ON PLATES WHICH CANNOT BE REMOVED BY RECHARGING.**

## E. General Cleaning

Clean engine, battery, seat, finish, etc. of all foreign matter.

## F. Store in a Clean Dry Area

# TROUBLESHOOTING

POSSIBLE CAUSE	CAUSE/ REMEDY (SEE INDEX)
<b>WILL NOT START</b>	<p>Push Clutch/Brake Pedal into Brake Position            Move Attachment Clutch Switch to "Disengaged Position"            Fill Tank with Gasoline. Check Fuel Line and Carburetor            (clean if necessary) Replace Fuel Filter            Check fuse for fault and replace            Recharge or replace Battery            Check Wiring            Replace Spark Plugs and adjust gap</p>
<b>WILL NOT TURN OVER</b>	<p>Charge Battery            Replace Ignition Switch            Engage Clutch/Brake Pedal            Move Attachment Clutch Switch to "Disengaged Position"            Replace Interlock Switch            Replace Solenoid            Replace Fuse            Check All Wire Connections</p>
<b>ENGINE CLICKS BUT WON'T START</b>	<p>Replace Starter            Charge or Replace Battery</p>
<b>HARD TO START</b>	<p>Place Throttle Control in "FAST" position            and run starter several times to clear out gas            Remove and clean Fuel Tank and lines Replace Fuel Filter            Remove Air Filter and clean            Replace Spark Plugs and adjust gap            Replace Battery            Check the wiring and Spark Plugs            Drain Fuel Tank and Carburetor. use fresh fuel and            Replace Spark Plugs            Make necessary adjustments to Carburetor            Major Engine Overhaul</p>
<b>ENGINE MISSES OR LACKS POWER</b>	<p>Shift to a lower gear or reduce load            Remove and clean Tank; replace Fuel Filter            Remove and clean Air Cleaner            Make necessary carburetor adjustments            Clean Air Screen            Replace Spark Plugs            Add or change oil            Check Spark Plugs and check for any loose wires            Major Engine overhaul            Drain Gas Tank and Carburetor and refill</p>
<b>ENGINE OVERHEATS</b>	<p>Clean Air Screen            Add or change oil            Clean Engine Cooling Fins            Remove and clean Muffler or replace            Remove and clean Air Filter            Use fresh fuel and adjust Carburetor</p>
<b>NO LIGHTS</b>	<p>Check Fuse, Switch and Wire Connections            Replace Headlight Bulbs</p>
<b>WON'T CHARGE</b>	<p>Check for Fuse fault and replace            Replace Battery            Replace Regulator            Replace Alternator</p>
<p><b>OPERATOR PRESENCE SYSTEM WILL NOT SHUT DOWN ENGINE WHEN OPERATOR LEAVES SEAT</b>            NOTE: THIS TRACTOR IS EQUIPPED WITH AN OPERATOR PRESENCE SENSING SYSTEM. ANY ATTEMPT BY THE OPERATOR TO LEAVE THE SEAT WITH THE ENGINE RUNNING AND THE ATTACHMENT CLUTCH ENGAGED WILL SHUT DOWN THE ENGINE.</p>	<p>Engage Attachment Clutch            Check All Wire Connections            Check Seat Switch            Check Operator Presence Relay            Check PTO Switch</p>



# TROUBLESHOOTING

<p><b>UNSATISFACTORY MOWER PERFORMANCE UNEVEN DISTRIBUTION OF CLIPPINGS</b></p>	<p><i>Place throttle controls in "FAST" position. Check air pressure in tires Check front to rear and side to side mower adjustment Use a slower ground speed Replace mower blades Reinstall mower blades with top of blades up Re-adjust mower drive belt Clean underside of mower deck Sharpen blades</i></p>
<p><b>MOWER BLADES WILL NOT ROTATE</b></p>	<p><i>Install new Mower Drive Belt Reinstall Mower Drive Belt Replace Attachment Clutch Switch Replace Frozen Mandrel Replace Frozen Pulley</i></p>
<p><b>EXCESSIVE MOWER VIBRATION</b></p>	<p><i>Replace Bent or Unbalanced Blade Replace Mandrel, Straighten Deck or replace</i></p>
<p><b>WIND ROWING, STRIPPING, OR DROPPING OF GRASS CLIPPINGS</b></p>	<p><i>Let grass dry out Clean underside of Mower Deck Level Mower Replace Blades</i></p>
<p><b>UNEVEN CUT OR SCALPING</b></p>	<p><i>Level Mower Adjust Gauge Wheels Replace Blades</i></p>

# SERVICE RECORD

<p><b>SERVICE RECORD</b></p> <p>Fill in dates as you complete regular service</p>	<p><b>SCHEDULE</b></p>							
	<p>FIRST 2 HOURS</p>	<p>EVERY 5 HOURS</p>	<p>EVERY 25 HOURS</p>	<p>EVERY 50 HOURS</p>	<p>EVERY 100 HOURS</p>			
Blades			X					
Brake Adjustment			X					
Check Battery				X				
Change Engine Oil	X			X				
Check Engine Oil Level		X						
Clean Air Cleaner Element				X				
Check Muffler				X				
Clean Air Screen				X				
Clean Front Grill				X				
Lubricate Tractor				X				
Replace Spark Plugs					X			
Replace Air Cleaner Element					X			
Tires			X					

Sears, Roebuck and Co. reserves the right to make any changes in design or improvements without imposing any obligation to install the same upon its terms heretofore manufactured.

# GT TWIN GARDEN TRACTOR – MODEL NUMBER 917.255919

## SCHEMATIC

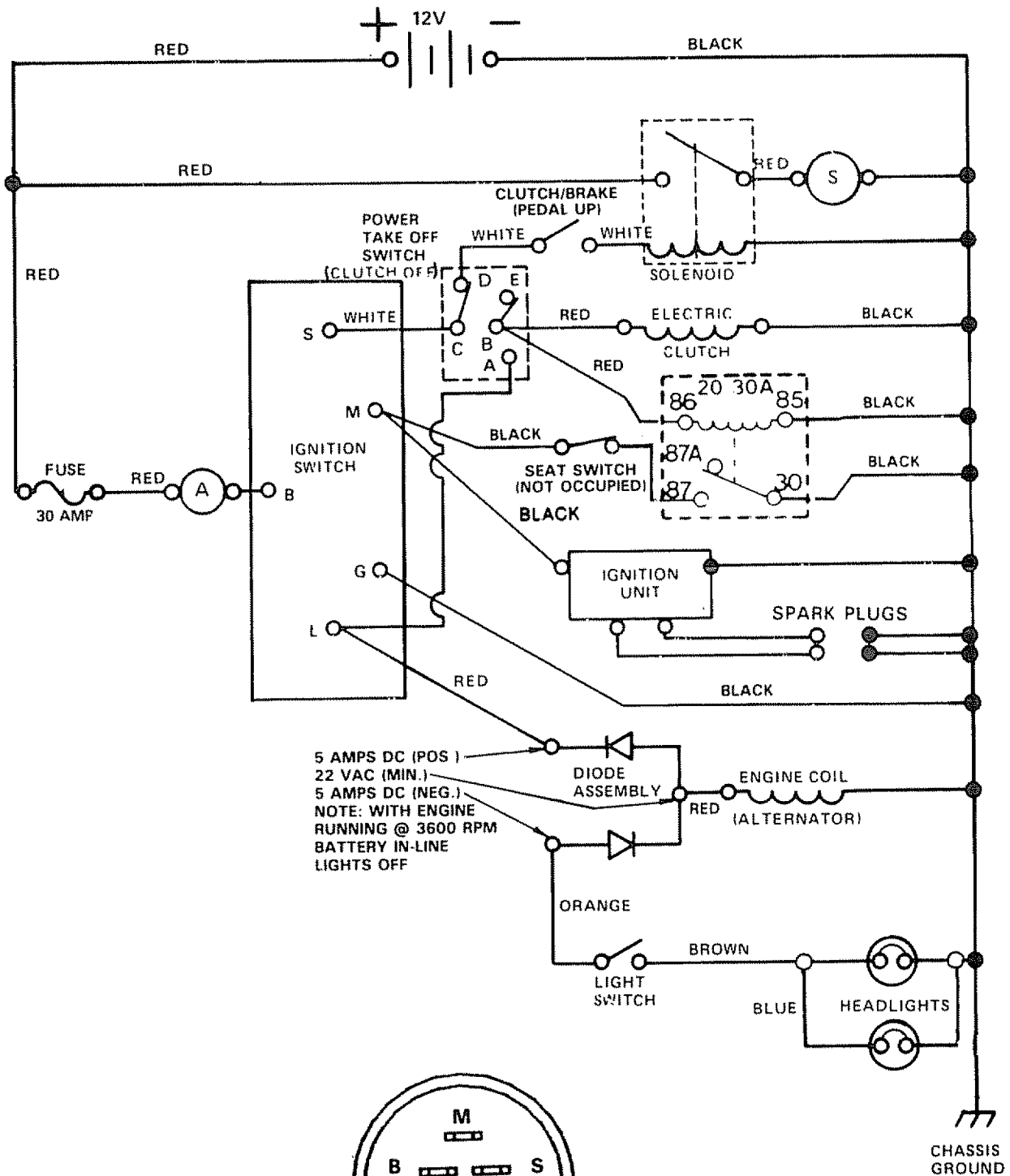

**IGNITION SWITCH**

POSITION	CIRCUIT
OFF	M-G
ON	B-L
START	B-S

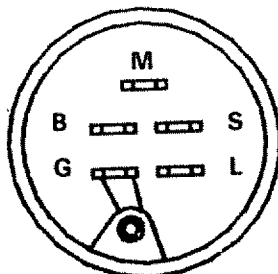

**WIRING INSULATED CLIPS**  
 NOTE: IF WIRING INSULATED CLIPS WERE REMOVED FOR SERVICING OF UNIT, THEY SHOULD BE REPLACED TO PROPERLY SECURE YOUR WIRING

**PTO SWITCH**

POSITION	CIRCUIT MAKE
OFF	B&E, C&D
ON	B&A

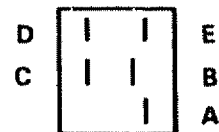

# REPAIR PARTS

## GT TWIN GARDEN TRACTOR -- MODEL NUMBER 917.255919

### ELECTRICAL

30



# REPAIR PARTS

## GT TWIN GARDEN TRACTOR – MODEL NUMBER 917.255919

### ELECTRICAL

KEY NO.	PART NO.	DESCRIPTION	KEY NO.	PART NO.	DESCRIPTION
1	109310X	Key	25	11050600	Washer - Lock - Ext. Tooth 3/8 "
2	STD365402	Switch - Ignition	26	4021J	Switch - P.T.O.
3	109787X	Bezel - Ignition	27	4022J	Nut - Hex
4	109788X	Nut - Ignition	28	4799J	Cable - Battery
5	4171 R	Clip	29	719J	Cover - Terminal
6	121443X	Switch - Light	30	74641008	Screw 10- 32 x 1/2
7	121537X	Battery	31	5115J	Cable - Starter
8	7603J	Tray - Battery	32	109550X	Clutch - Electric
9	100541K	Tube - Drain	33	106367X	Spacer - Clutch
10	109596X	Clamp - Hose	34	108170X	Stop - Clutch
11	109081X	Solenoid	35	19132203	Washer
12	10090400	Washer - Lock 1/4	36	STD551137	*Washer - Lock 3/8
13	STD541225	*Nut - Hex Jam 1/4 - 20	37	72240460	Bolt - Carriage 1/4 - 20 x 7 - 1/2
14	17190408	Screw - Hex Washer Thread Cutting 1/4 - 20 x 1/2	39	123198X	*Nut - Wing 1/4 - 20
15	104445X	Switch - Interlock	40	102476X	Guard - Terminal
16	71031008	Screw - Hex Washer No. 10 - 32 x 1/2	41	STD522507	*Bolt - Hex 1/4 - 20 x 3/4
17	73951000	Nut - Keps No. 10 - 32	42	STD551025	*Washer 9/32 x 5/8 x 16 Ga.
18	106315X	Diode Assembly	43	STD541025	*Nut - Hex 1/4 - 20
19	121478X	Harness - Ignition	44	STD551125	*Washer - Lock 1/4
20	4152J	Bulb - Headlight	45	110859X	Harness - Light Socket
21	108824X	Fuse - 30 Amp	46	121305X	Switch, Plunger
22	74610628	Bolt - Hex 3/8 - 24 x 1 - 3/4	48	109748X	Relay - Operator Presence
23	STD523707	*Bolt - Hex 3/8 - 16 x 3/4	49	121264X	Cap Set - Battery
24	121080X	Cable - Ground	50	121433X	Ammeter
			51	121651X	Decal, Battery
			--	101539X	Sheet - Instruction, Tractor 15° Slope
			--	123611X	Manual - Owners

\*STANDARD HARDWARE--PURCHASE LOCALLY

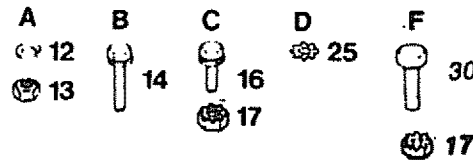

# REPAIR PARTS

GT TWIN GARDEN TRACTOR – MODEL NUMBER 917.255919

## CHASSIS AND ENCLOSURES

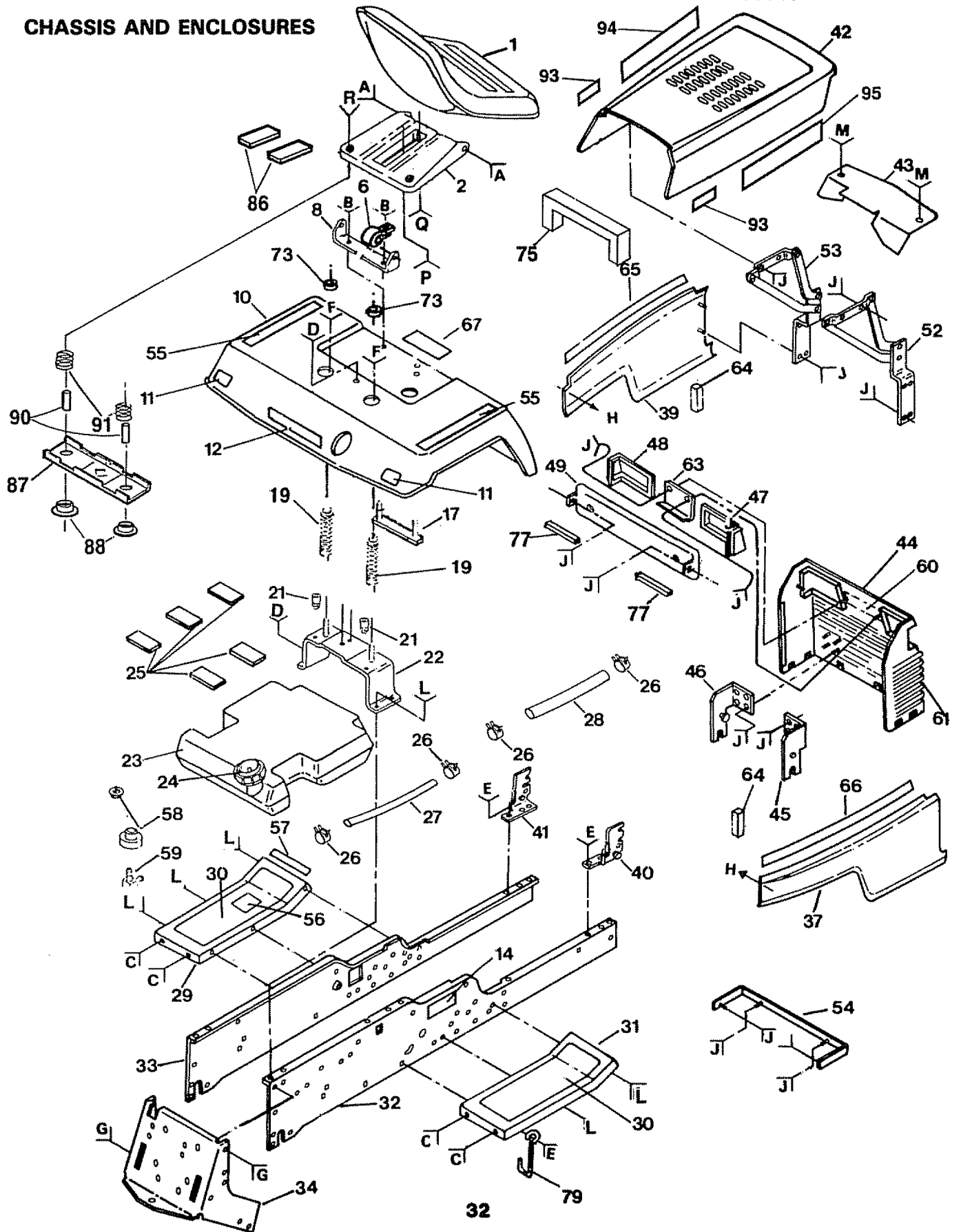

# REPAIR PARTS

## GT TWIN GARDEN TRACTOR -- MODEL NUMBER 917.255919

### CHASSIS AND ENCLOSURES

KEY NO.	PART NO.	DESCRIPTION	KEY NO.	PART NO.	DESCRIPTION
1	120066X	Seat	49	110897X	Bezel
2	121247X	Pan - Seat	51	108067X	Nut - Pal
3	105529X	Bolt - Shoulder	52	106091X	Hinge - R H
5	73680500	Nut - Lock 5/16 - 18	53	106090X	Hinge - L H
6	2751R	Clip	54	110350X361	Strap - Grill
8	105513X	Bracket - Pivot, Seat	55	109139X	Decal - Fender
9	73680600	Nut - Lock 3/8 - 16	56	106868X	Decal - Drive Belt Schematic
10	121642X361	Fender	57	4900J	Decal - Clutch/Brake
11	106202X	Reflector - Taillight	58	3645J	Bushing
12	105801X	Decal	59	8710J	Stem - Fuel Tank
13	STD523707	*Bolt - Hex 3/8 - 16 x 3/4	60	105806X	Decal - Grill
14	105567X	Decal - Chassis	61	105568X	Decal - Grill (Stripe)
15	17490608	Screw - Hex Washer Thread Rolling 3/8 - 16 x 1/2	62	19131416	Washer 13/32 x 7/8 x 16 Ga
16	17490616	Screw - Hex Washer Thread Rolling 3/8 - 16 x 1	63	106092X	Support - Heat Shield
17	105511X	Strap - Fender	64	106088X	Strip - Foam
19	121067X	Spring - Compression,	65	106813X	Decal - Stripe, Side Panel L.H.
21	105531X	Nut - Push	66	106814X	Decal - Stripe, Side Panel R.H.
22	105509X	Bracket - Fender	67	106974X	Decal - Caution
23	106020X	Tank - Fuel	70	106909X	Screw - Special
24	121221X	Cap - Fuel	71	106910X	Washer
25	106082X	Pad - Spacer	72	108402X	U-Clip
26	6999R	Clamp - Hose	73	121093X	Cap. Spring
27	7834R	Line - Fuel	74	19131614	Washer, 13/32 x 1 x 14 Ga
28	7833R	Line - Fuel	75	106086X	Strip, Foam
29	105465X361	Footrest - L.H.	77	105036X	Strip, Foam
30	105466X	Pad - Footrest	79	105500X	Retainer, Belt, Lower
31	105464X361	Footrest - R.H.	80	121144X	Shoulder Bolt, 5/16 - 18 UNC
32	110892X	Rail - Frame - R.H.	81	19131312	Washer 13/32 x 13/16 x 12 Ga.
33	110893X	Rail - Frame L.H.	82	74780816	Screw, Hex 1/2 - 13 x 1 Gr 5
34	7982J	Drawbar	83	10040800	Lockwasher, 1/2
35	74760716	Bolt - Hex 7/16 - 14 x 1	84	19171912	Washer, 17/32 x 1 3/16 x 12 Ga
36	73680700	Nut - Lock 7/16 - 14	85	17490612	Screw Hex Trd. Roll 3/8 x 16 x 3/4
37	108403X361	Panel - Side, R.H.	86	121251X	Strip, Foam
39	108410X361	Panel - Side, L.H.	87	121246X	Switch Bracket
40	121054X	Bracket - Pivot, Frame, R.H.	88	121248X	Snap Bushing
41	121055X	Bracket - Pivot, Frame, L.H.	89	72170410	Bolt, Carr. 1/4 - 20 x 1 1/4
42	106013X361	Hood	90	121249X	Spacer, Split
43	110875X	Shield - Heat, Front	91	121250X	Spring
44	105528X	Grill	92	73900400	Nut, Hex Flange 1/4 - 20
45	108512X	Bracket - Pivot, Grill, R.H.	93	105562X	Decal, 18 H.P.
46	108513X	Bracket - Pivot, Grill, L.H.	94	108743X	Decal, Stripe L.H.
47	106003X	Lens R.H.	95	108744X	Decal, Stripe R.H.
48	106004X	Lens L.H.			

\*STANDARD HARDWARE - PURCHASE LOCALLY

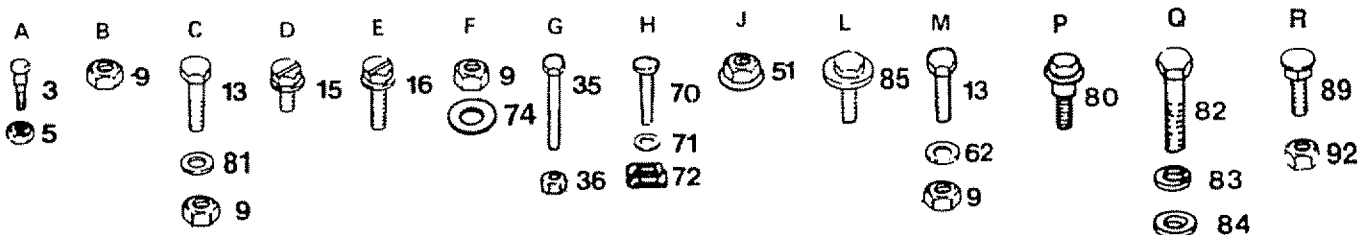

# REPAIR PARTS

## GT TWIN GARDEN TRACTOR -- MODEL NUMBER 917.255919

### GROUND DRIVE

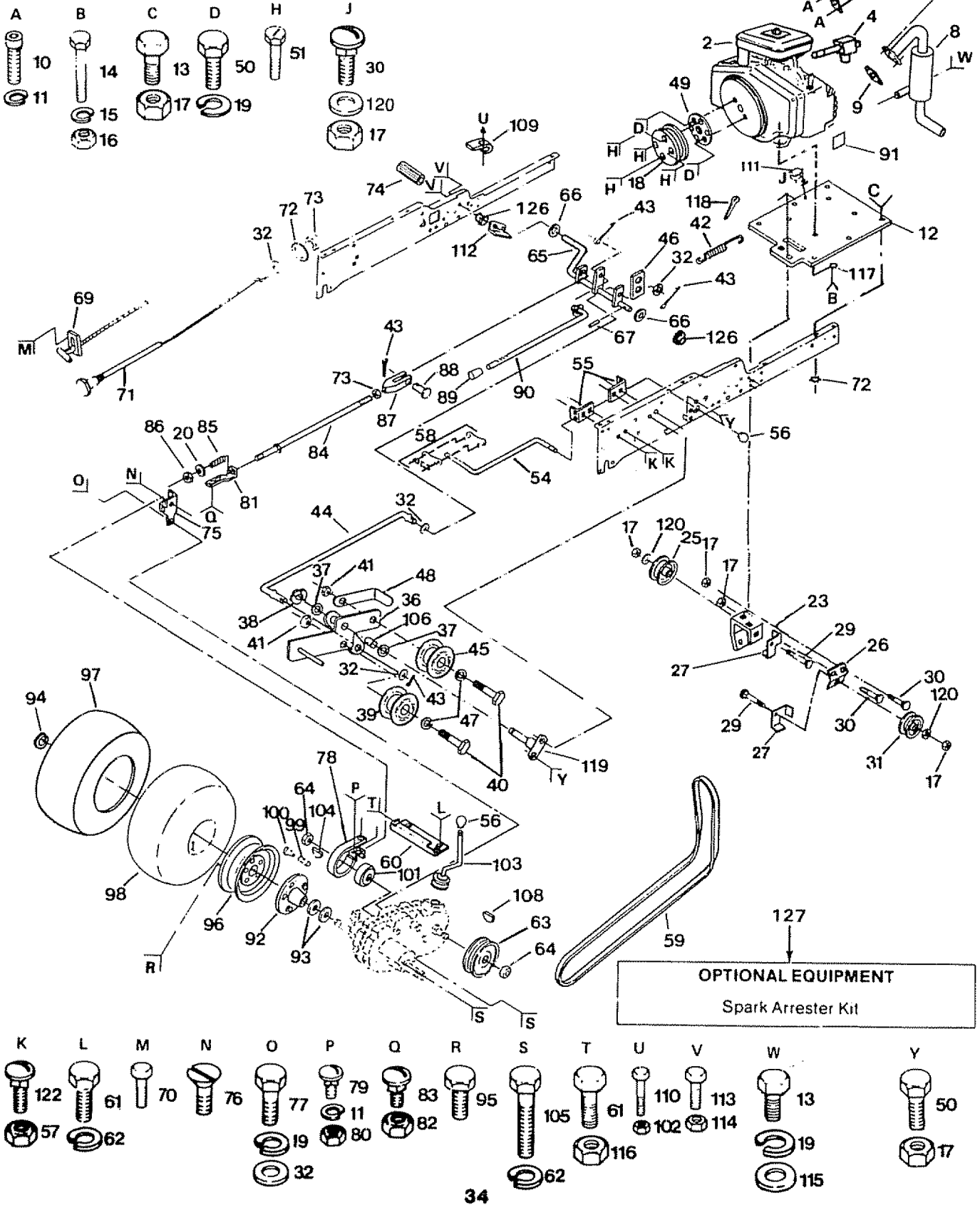

# REPAIR PARTS

## GT TWIN GARDEN TRACTOR – MODEL NUMBER 917.255919

### GROUND DRIVE

KEY NO.	PART NO.	DESCRIPTION	KEY NO.	PART NO.	DESCRIPTION
2	110864X	Engine Model Number 422437 Type 1209 Trim 01	67	STD571812	*Pin, Roll, 3/16 x 1 - 1/4
4	120374 X	Valve, Oil Drain	69	121468X	Control, Throttle
6	110890X	Tube - Exhaust	70	17720408	Screw, Hex, Thd Cut 1/4-20 x 1
8	110887X	Muffler	71	121389X	Control, Choke
9	8545J	Gasket, Muffler	72	11050600	Washer, Lock Ext Tooth 3/8
10	74570412	Screw, Socket Hd., 1/4 - 20 x 3/4	73	STD541137	*Nut, 3/8-24
11	STD551125	*Washer, Lock, 1/4	74	8883R	Cover, Pedal
12	110867X	Base, Engine	75	677A637	Bracket, Brake
13	STD523707	*Bolt, Hex, 3/8 - 16 x 3/4	76	74370612	Screw, Mach., Unct Fl. Hd., 3/8 - 16 x 3/4
14	STD523112	Bolt 5/16 - 18 x 1 - 1/4	77	74760614	Bolt, Hex, 3/8 - 16 x 7/8
15	STD551131	Washer Lock 5/16	78	7920J	Band, Brake
16	STD541031	Nut 5/16 - 18	79	72140405	Bolt, Carr. 1/4 - 20 x 5 8
17	73680600	Nut, Lock, 3/8 - 16	80	STD541025	*Nut, Hex, 1/4 - 20
18	121355X	Pulley, Ground Drive	81	7229J	Guide, Rod, Brake
19	STD551137	*Washer, Lock, 3/8	82	1685H	Nut, Lock, 5/16 - 18
20	19131614	Washer, 13/32 x 1 x 14 Ga.	83	STD533110	*Bolt, Carr. 5/16 - 18 x 3/4
23	121063X	Bracket, V-Pulley, Drive, Mule	84	5308J	Rod, Brake
25	101344L	Pulley	85	7241J	Spring, Compression
26	122825X	Bracket, Idler, Flat	86	73530600	Nut, Lock, 3/8 - 24
27	122824X	Guard, Belt, Mule Drive	87	100604K	Yoke
29	72110614	Bolt, Carr. 3/8 - 16 x 1-3/4	88	5102J	Pin, Clevis
30	STD533707	*Bolt, Carr., 3/8 - 16 x 3/4	89	71673	Cap, Plunger
31	102403X	Idler, Flat	90	109767X	Rod, Parking Brake
32	STD551037	*Washer, 13/32 x 13/16 x 16 Ga.	91	110042X	Decal, Engine
36	121356X	Bracket, Clutch w/Bearing (Inc. Key No. 106)	92	634A692	Bushing and Wheel Hub
37	207J	Washer, Hardened	93	7563R	Washer, Thrust Axle
38	12000039	Klip Ring	94	12000034	Klip Ring
39	121361X,	Idler, Grooved	95	1304H	Bolt, Hub
40	STD523715	* Bolt, Hex 3/8 - 16 x 1 3/4	96	106277X361	Wheel, Rear
41	73930600	Nut, Lock, 3/8 - 16	97	105588X	Tire, Rear
42	121357X	Spring Extension Clutch	98	7154J	Tube, Tire (Not furnished)
43	STD570907	*Pin, Cotter 3/32 x 3/4	99	65139	Valve, Tire
44	101356L	Rod, Clutch	100	59192	Cap, Valve
45	104360X	Idler, Flat	101	214J	Drum, Brake
46	121358X	Retainer, Spring	102	STD541410	*Nut - Lock No 10 - 24
47	19131413	Washer, 13/32 x 7/8 x 13 Ga.	103	633A109	Gear Shift Lever Assembly
48	121360X	Retainer, Belt	104	2228M	Key, Woodruff
49	104577X	Adapter	105	74760724	Bolt, Hex 7/16 - 14 x 1 - 1/2
50	STD523710	*Bolt, Hex, 3/8 - 16 x 1 Gr. 5	106	105706X	Bearing - Idler
51	17190516	Screw, Hex, Thd. Cut 5/16 - 18 x 1	108	9858M1	Key - Woodruff
54	122253X	Rod, Shift, Hi-Lo	109	5304J	Actuator - Switch, Interlock
55	105598X	Bracket, Rod, Shift	110	74321016	Screw - Fin 10 - 24 x 1
56	100196K	Knob	111	2751R	Clip
57	73680500	Nut, Lock, 5/16 - 18	112	104601X	Bracket - Interlock
58	122268X	Connecting Link Spring Clip	113	STD522507	*Bolt - Hex 1/4 - 20 x 3/4
59	110883X	V-Belt	114	73680400	Nut - Crownlock 1/4 - 20
60	120404X	Bracket, Support, Transaxle	115	19131210	Washer 13/32 x 3/4 x 10 Ga
61	74760716	Bolt, Hex, 7/16 - 14 x 1	116	73680700	Nut - Crownlock 7/16 - 14
62	STD551143	*Washer, Lock 7/16	117	11050500	Washer - Lock Ext Tooth 5'16
63	120332X	Pulley, Transaxle	118	76020816	Pin - Cotter 1/4 x 1
64	9204H	Nut, Lock, 1/2 - 20	119	101358K	Bracket - Assembly Clutch
65	104375X	Shaft, Foot Pedal	120	19131612	Washer 13/32 x 1 x 12 Ga.
66	121749X	Washer, 25/32 x 1 - 1/4 x 16 Ga.	122	72140506	Bolt - Carriage 5/16 - 18 x 3/4
			126	110895X	Nyliner
			127	120615X	Spark Arrester Kit

\*STANDARD HARDWARE – PURCHASE LOCALLY





# REPAIR PARTS

## GT TWIN GARDEN TRACTOR - MODEL NUMBER 917.255919

### STEERING

KEY NO.	PART NO.	DESCRIPTION	KEY NO.	PART NO.	DESCRIPTION
1	106230X	Tire. 16 x 6 50	48	106042X012	Cover. Gate. Shift
2	8134H	Tube, Front (not furnished with tractor)	49	17720408	Screw, Hex Washer Thd Cutting 1 4 - 20 x 1 2
3	106228X361	Front Wheel (Inc Key No 3 and of Key No. 4)	50	105810X	Decal, Insert
4	278H	Fitting. Grease	51	100710L	Cap, Steering Wheel
5	9040H	Bearing	52	74760880	*Bolt - Hex 1/2 - 13 x 5
6	106045X	Spindle. R.H	53	73680800	Nut, Lock 1/2 - 13
7	6266H	Bearing. Thrust	54	19172610	Washer 17/32 x 1 - 5 8 x 10 Ga
8	12000029	Klip Ring	55	120542X	Bracket Idler
9	5284J	Bracket, Axle	56	677A451	Pulley Idler
10	STD523707	*Bolt - Hex 3/8 - 16 x 3/4	57	7190J	Spring
11	73680600	Nut, Lock. 3/8 - 16	58	STD523720	*Bolt Hex 3/8 - 16 x 2 1/4
12	674A244	Axle, Front (Inc. Key 13)	59	19131413	Washer 13/32 x 7 8 x 13 Ga
13	1309H	Bearing	60	STD541037	*Nut - Hex 3/8 - 16
14	5298J	Tube, Pivot, Axle	61	5213J	Bracket, Frame Front
15	74781044	Bolt, Hex 5/8-11 x 2-3/4 Gr. 5	62	73680500	Nut, Lock 5 16 - 18
16	STD551162	*Washer, Lock 5/8	63	7985J	Support Battery
17	STD541062	*Nut, Hex 5/8 - 11	64	65139	Stem Valve
18	6855M	Fitting. Grease	65	59192	Cap Valve
19	106046X	Spindle. L H	66	121377X011	Dashplate
20	120424X	Sector Assembly	67	108456X	Decal, Instruction
21	110497X	Link, Drag	68	106615X	Pin, Mounting Idler Bracket
22	STD551137	*Washer, Lock 3/8	69	2751R	Clip
23	STD541137	*Nut, Hex 3/8 - 24	70	109850X	Joint - Tie Rod - R.H. Threac
24	5292J	Bushing, Bellcrank	71	109851X	Joint - Tie Rod - L.H. Threac
25	108137X	Bellcrank	72	7919J	Rod - Tie
26	19292016	Washer 29/32 x 1 - 1/4 x 16 Ga.	73	73700600	Nut - Hex Jam 3/8 - 24 L.H.
27	109849X	Rod, Tie	74	STD541337	*Nut - Hex Jam 3/8 - 24
28	STD523720	*Bolt, Hex 3/8 - 16 x 2 Gr. 5	75	STD533107	*Bolt - Carriage 5/16 - 18 x 3/4
29	102933X	Spacer, Split	76	121749X	Washer 13/32 x 1 - 1/4 x 16 Ga.
30	102439X	Bracket, Support. Steering	77	121748X	Washer 25/32 x 1 - 5/8 x 16 Ga.
31	104239X	Bearing, Flanged	78	74930516	Bolt Hex 5/16 - 18 x 1
32	72110608	Bolt, Carr 3/8 - 16 x 1 Gr. 5	79	104757X	Cap - Hub Front
33	101274N	Support. Steering	80	100644K	Bushing - Handle
34	17490612	Screw, Hex Washer Thd Rolling 3/8 - 16 x 3 4	81	19111416	Washer 11/32 x 7/8 x 16 Ga
35	102458X	Shaft, Steering	82	STD523710	*Bolt, Hex 3/8 - 16 x 1 Gr 5
36	12000034	Klip Ring	83	100207K	Clip - 3/8
37	100713N	Wheel, Steering	84	108367X	Decal - Adjustment
38	100711L	Adapter. Steering	85	120199X	Tube
39	19133808	Washer	86	121177X	Collar
40	106014X	Sleeve. Steering	87	110946X	Spindle Stop
41	9038R	Bearing	88	19133807	Washer 13/32 x 1 - 1/4 x 7 Ga.
42	105519X	Dash. Lower	89	8022J	Dash Plug
43	120028X	Dash	90	121748X	Washer 25/32 x 1 - 5/8 x 16 Ga.
44	105525X	Bracket, Support. Dash	91	121232X	Cap, Spindle
45	19171416	Washer 17/32 x 7/8 x 16 Ga.	92	74180412	Screw, Mach. Cr. 1/4 - 20 x 3/4
46	72110622	Bolt - Carr 3/8 - 16 x 2 3/4	93	19091216	Washer 9/32 x 3/4 x 16 Ga.
47	121235X	Spacer	94	73510400	Nut - Hex Keps 1/4 - 20
			95	4171R	Clip

\*STANDARD HARDWARE--PURCHASE LOCALLY

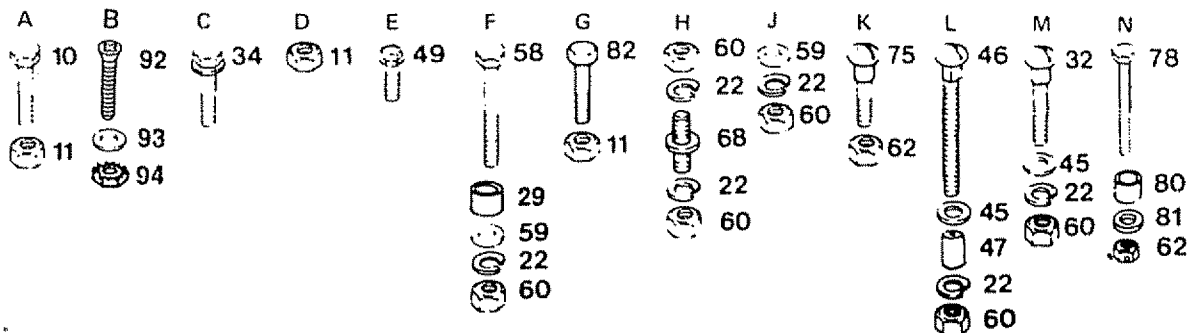

# REPAIR PARTS

## GT TWIN GARDEN TRACTOR – MODEL NUMBER 917.255919

### MOWER LIFT

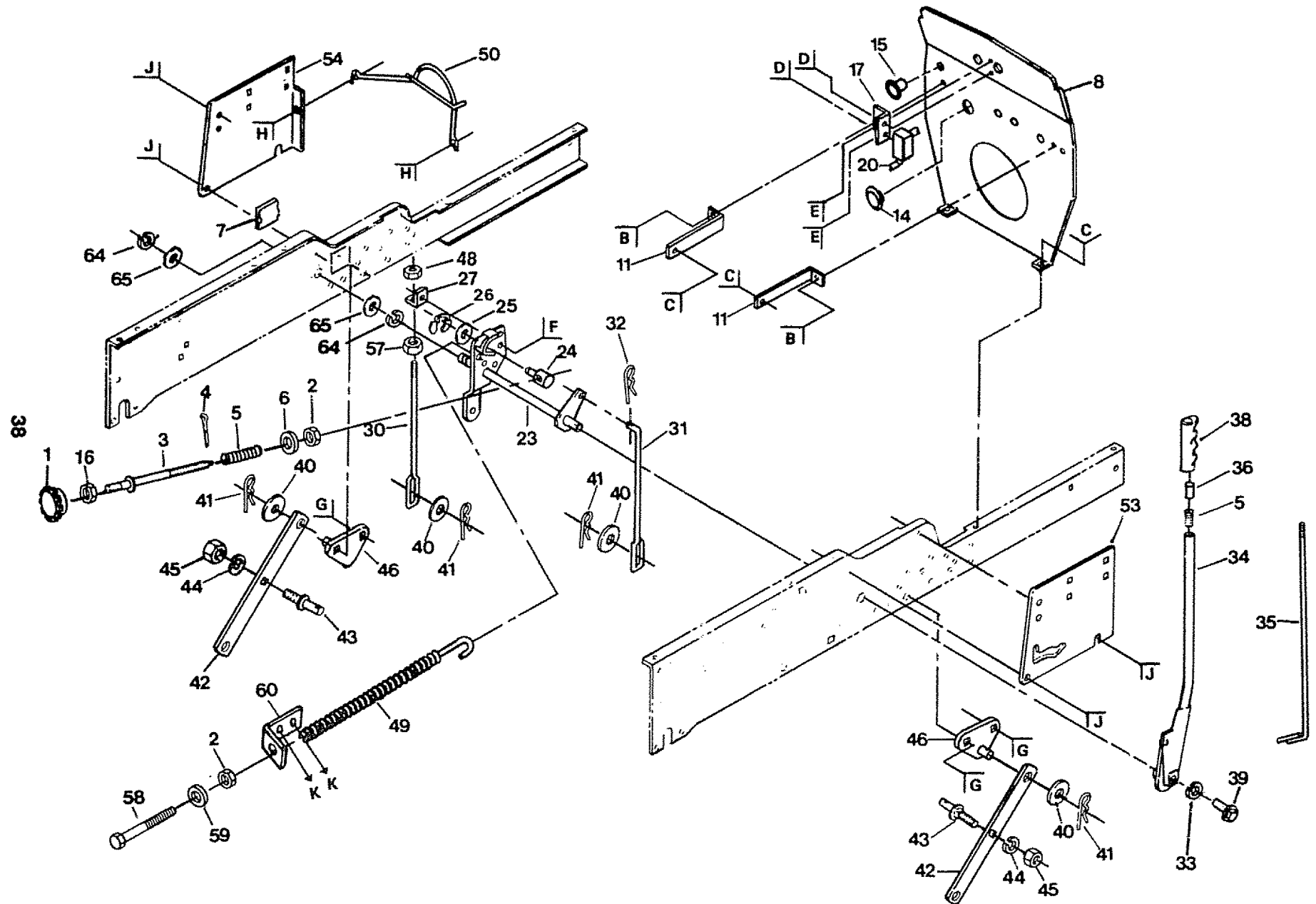

# REPAIR PARTS MOWER LIFT

## GT TWIN GARDEN TRACTOR – MODEL NUMBER 917.255919

KEY NO.	PART NO.	DESCRIPTION	KEY NO.	PART NO.	DESCRIPTION
1	100734K	Handle, Adjust, Lift	34	121002X	Lever Lift
2	110807X	Nut	35	12-1006X	Rod, Detent
3	110811X	Rod, Adjust, Lift	36	105723X	Plunger, Lever
4	STD570907	*Pin, Cotter, 3/32 x 3/4	37	STD523710	*Bolt - Hex 3/8 - 16 x 1
5	2876H	Spring	38	109413X	Grip, Handle
6	19131016	Washer 13/32 x 5/8 x 16 Ga.	39	74780624	Bolt, Hex 3/8 - 16 x 1 1/2
7	121794X	Cover, Access			
8	110871X	Shield, Heat, Rear	40	STD551050	*Washer 17/32 x 1 - 1/16 x 13 Ga.
9	STD523107	*Bolt, Hex, 5/16 - 18 x 3/4	41	9135R	Retainer Spring
10	73680500	Nut, Lock, 5/16 - 18	42	105429X	Arm, Suspension
11	120350X	Brace, Heat Shield	43	105413X	Stud, Pivot Center
12	STD522505	*Bolt, Hex, 1/4 - 20 x 1/2 Gr. 5	44	STD551150	*Washer, Lock, 1/2
13	73680400	Nut, Lock, 1/4 - 20	45	STD541050	*Nut, Hex, 1/2 - 13
14	106351X	Plug	46	105501X	Bracket, Suspension, Mower
15	110436X	Grommet, Split	47	STD533707	*Bolt, Carriage, 3/8 - 16 x 3/4
16	73350600	Nut - Hex Jam 3/8 - 16 UNC	48	73680600	Nut, Lock, 3/8 - 16
17	105040X	Bracket, Fuel Pump	49	674A247	Spring - Ass'y. Assist. Lift
18	74750806	Screw, Sl. Hex Hd. No. 8 - 32 x 3/8	50	110908X	Guard, Belt, Engine
19	STD551108	*Washer, Lock No. 8	51	STD533110	*Bolt, Carriage, 5/16 - 18 x 1
20	105041X	Pump, Fuel	52	19111610	Washer 11/32 x 1 x 10 Ga.
21	STD511005	*Screw, Hex Hd. No. 10 - 24 x 1/2	53	121045X	Panel, Pnt. Side, R.H.
22	73631000	Nut, Lock No. 10 - 24	54	121046X	Panel, Pnt. Side, L.H.
23	120137X	Shaft, Lift	55	17490608	Bolt, Hex Washer Thd. Rolling 3/8 - 16 x 1/2
24	110810X	Trunnion, Stop Depth	57	STD541037	*Nut, Hex 3/8 - 16
25	19151216	Washer 15/32 x 3/4 x 16 Ga.	58	5328J	Bolt - Adjust, Spring, Assist
26	12000037	Klip Ring	59	STD551037	*Washer 13/32 x 13/16 x 16 Ga.
27	7594J	Bracket, Lift, L.H.	60	5329J	Bracket, Spring - Assist
28	7901J	Bolt, Shoulder			
29	73900400	Nut, Hex Flange 1/4 - 20	62	73930600	Nut Centerlock 3/8 - 16
30	7596J	Link, Lift, L.H.	64	12000022	Klip Ring
31	105503X	Link, Lift, R.H.	65	19292016	Washer 29/32 x 1 - 1/4 x 16 Ga.
32	4939M	Retainer, Spring			
33	74760616	Washer, Lock 3/8			

\*STANDARD HARDWARE--PURCHASE LOCALLY

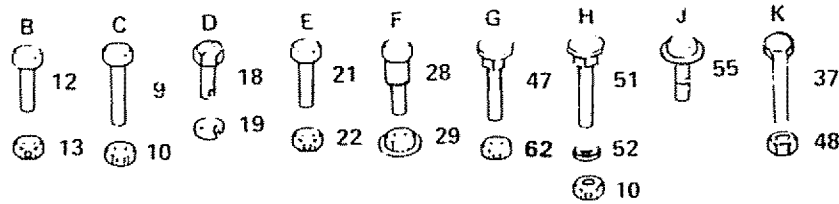



# REPAIR PARTS

## GT TWIN GARDEN TRACTOR -- MODEL NUMBER 917.255919

### MOWER

KEY NO.	PART NO.	DESCRIPTION	KEY NO.	PART NO.	DESCRIPTION
1	105415X	Housing, Mower	36	105453X	Bar, Ga Wheel
2	106022X	Cover - Drive, Deck	37	5565J	Pin, Clevis
3	17490508	Screw - Hex Washer Thd. Roll 5/16 - 18 x 1/2	38	4939M	Retainer, Spring
4	7631J	Runner, L.H.	39	4898H	Bolt, Shoulder
5	72110505	Bolt, Carr 5/16 - 18 x 5/8	40	105455X	Wheel, Gauge
6	STD551131	*Washer - Lock, 5/16	41	105433X	Brkt. Suspension
7	STD541031	*Nut - Hex 5/16 - 18	42	110237X	Spacer
8	8418J	Runner, R.H.	43	105434X	Brace, Suspension
9	72140506	Bolt, Carr 5/16 - 18 x 3/4	44	105436X	Parallel Link
10	1685H	Nut, Lock 5/16 - 18	45	105441X	Brkt. Suspension
11	STD551031	*Washer 11/32 x 11/16 x 16 Ga	46	121343X	Decal - Warning
12	121658X	Mandrel - Secondary	47	3146R	Retainer - Spring
13	121657X	Mandrel - Primary	48	106381X	V-Belt
14	17490612	Screw - Hex Washer Thd. Roll 3/8 - 16 x 3/4	49	STD541050	*Nut, 1/2 - 13
15	106635X	Blade	50	74760622	Bolt, Hex 3/8 - 16 x 1 - 3/8
16	STD623715	*Bolt - Hex, 3/8-24 x 1-1/2 Gr. 5	51	105435X	Pin, Release
17	STD551137	*Washer - Lock, 3/8	52	3720R	Spring
18	19132012	Washer 13/32 x 1 - 1/4 x 12 Ga	53	12000039	Ring, Klip
19	674A213	Arm Assembly, Idler	54	19171612	Washer 17/32 x 1 x 12 Ga
20	7834J	Liner, Bearing	55	105440X	Pin, Clevis
21	7835J	Bearing	56	105458X	Brkt. Outer, R.H.
22	72110522	Bolt, Carriage 5/16 - 18 x 2 - 3/4	57	105460X	Brkt. Inner, R.H.
23	19111610	Washer 11/32 x 1 x 10 Ga.	58	105461X	Brkt. Inner, L.H.
24	102403X	Pulley, Idler	59	105459X	Brkt. Outer, L.H.
25	STD523715	*Bolt - Hex 3/8 - 16 x 1 - 1/2	60	73680500	Locknut 5/16 - 18
26	STD541037	*Nut - Hex 3/8 - 16	61	120135X	Spacer
27	104361X	Spring	62	19111016	Washer 11/32 x 5/8 x 16 Ga
28	STD523112	*Bolt - Hex 5/16-18 x 1-1/4 Gr. 5	63	109785X	Shield, Deflector
29	19111216	Washer 11/32 x 3/4 x 16 Ga	64	106734X	Spring, Deflector
30	8438J	Spacer	65	109743X	Bracket, Deflector
31	106224X	Decal - V-Belt, Dr. Schematic, Mower	66	106735X	Rod, Hinge
32	105448X	Bracket, Ga Wheel, R.H.	68	110452X	Push Nut
33	105449X	Bracket, Ga Wheel, L.H.	69	3713J	Instruction - Caution Decal
34	STD533707	*Bolt, Carriage 3/8 - 16 x 3/4	70	- - -	Decal - Safety Standard - Not Serviced
35	73680600	Nut, Crownlock 3/8 - 16	71	73680800	Lock Nut - Hex 1/2 - 13
			73	19171512	Washer 17/32 x 15.16 x 12 Ga
			74	72240608	Bolt, Carriage 3/8 16 x 1
			76	110884X	V-Belt
			77	19131614	Washer 13/32 x 1 x 14 Ga.
			78	121352X	Keeper, belt

\*STANDARD HARDWARE - PURCHASE LOCALLY

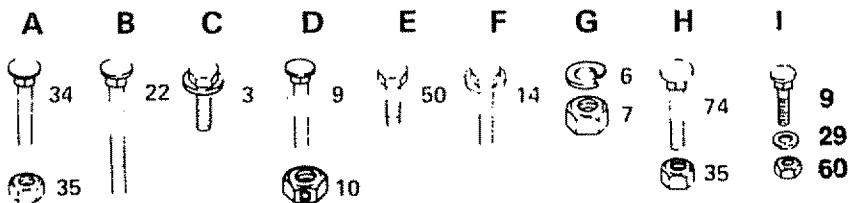

# REPAIR PARTS

TRANSAXLE

GT TWIN GARDEN TRACTOR – MODEL NUMBER 917.255919

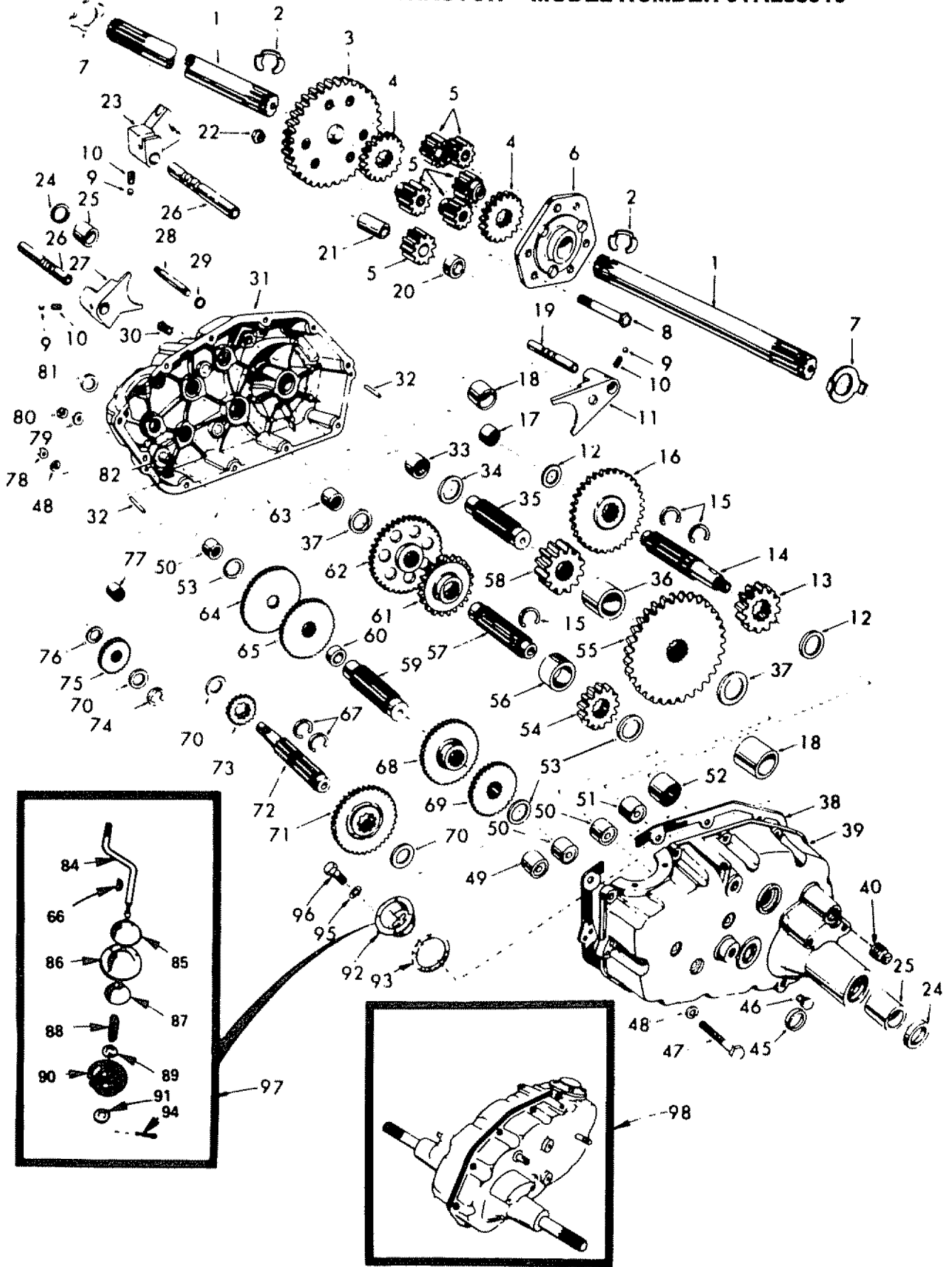

# REPAIR PARTS

## GT TWIN GARDEN TRACTOR -- MODEL NUMBER 917.255919

### TRANSAXLE

KEY NO	PART NO	DESCRIPTION	KEY NO	PART NO	DESCRIPTION
1	4197R	Axle Shaft	49	4895H	Needle Bearing
2	5845R	Retaining Ring	50	4222R	Needle Bearing
3	4199R	Final Drive Gear	51	1529R	Needle Bearing
4	4216R	Differential Gear	52	8119M	Needle Bearing
5	4215R	Differential Pinion	53	4220R	Thrust Bearing Race
6	4217R	Differential Carrier	54	4209R	3rd Reduction Pinion - Low
7	6256H	Axle Thrust Washer	55	4213R	4th Reduction Gear
8	74020652	Hex Bolt 3/8 - 24 x 3 - 1/4 (1" Thread Length)	56	4442R	3rd Reduction Pinion Spacer
9	7392M	Steel Ball	57	4195R	2nd Reduction Gear Shaft
10	6272H	Spring Shift Fork Detent	58	4214R	Final Drive Pinion
11	4985R	Shift Fork, High - Low Range	59	4194R	1st Reduction Gear Shaft
12	6266H	Thrust Bearing Race	60	7528R	1st Reduction Shaft Spacer
13	4212R	4th Reduction Pinion	61	4208R	3rd Reduction Pinion - High
14	4196R	3rd Reduction Gear Shaft	62	4207R	2nd Reduction Gear
15	6276H	Snap Ring - Crescent Type	63	7398H	Needle Bearing
16	633A63	High - Low Range Gears	64	4203R	Low Speed Gear and 2nd Reduction Pinion Cluster
17	8118M	Needle Bearing	65	4204R	Reverse Gear
18	8740H1	Sintered Iron Bearing	66	2898J	Key - Hi - Pro 1 B x 17 32
19	122238X	Shift Fork Shaft, High - Low Range	67	4926H	Snap Ring - Crescent Type
20	4218R	Differential Pinion Spacer	68	4205R	Intermediate Speed Gear
21	6252H1	Differential Pinion Bushing	69	4206R	High Speed Gear
22	7810H	Gripco Centerlock Nut 3/8 - 24	70	1370H	Thrust Bearing Race
23	4986R	Shift Fork - L.H.	71	633A69	Intermediate and High Speed Cluster Pinions
24	7393R	Oil Seal			
25	992R1	Sintered Iron Bearing	72	208J	Input Shaft
26	6216H	Shift Fork Shaft	73	4201R	Low Speed Pinion
27	6262H	Shift Fork - R.H.	74	12000002	E-Ring
28	122254X	Shift Shaft, High - Low Range	75	1153R	Reverse Idler Gear
29	6296H	Oil Seal	76	7392H	Reverse Idler Thrust Washer
30	5855H	Pressure Relief Valve	77	3990H	Needle Bearing
31	122162X	Gearcase, Reverse Idler Shaft and Bearings - R.H. (Inc. Key No's 17, 18, 25, 33, 50, 63, 76, 77 and 82)	78	73220500	Hex Nut 5/16 - 18
			79	1167R	Sealing Washer
32	6277H	Dowel Pin	80	73360700	Hex Jam Nut 7/16 20
33	4225R	Needle Bearing	81	6270H	Oil Seal
34	7396H	Thrust Bearing Race	82	7384H	Reverse Idler Shaft
35	4198R	4th Reduction Gear Shaft	84	5384J	Gear Shift Lever Bent
36	4200R	4th Reduction Gear Spacer	85	2978J	Gear Shift Cap
37	7395H	Thrust Bearing Race	86	633A85	Gear Shift Ball Cover and Pin
38	121878X	Gearcase Gasket	87	8739H1	Shift Lever Guide Ball - Keyed
39	122163X	Gearcase and Bearings - L.H. (Inc. Key No's. 18, 25, 49, 50 (2), 51 and 52)	88	4924H	Spring
			89	19151516	Washer 15/32 x 15/16 x 16 Ga.
			90	110542X	Shift Mechanism Seal
40	13320400	Pipe Plug 1/2 - 14 N.P.T.	91	19181511	Washer 9/16 x 15/16 x 12 Ga
45	6271H	Oil Seal	92	75J	Gear Shift Gate and Reinforcement
46	13060200	Pipe Plug 1/4 - 18 N.P.T.	93	6274H	Shift Ball Cover Gasket
47	74780524	*Hex Bolt 5/16 - 18 x 1 - 1/2 Grade 5	94	76020412	Cotter 1/8 x 3/4
48	10140500	Lockwasher 5/16 Extra Heavy	95	10040500	*Lockwasher 5 16
			96	74760514	*Hex Bolt 5/16 - 18 UNC x 7/8
			97	633A109	Gear Shift Lever Ass'y.
			98	122419X	Transaxle Assembly Less Brake Drum & Shift Lever

\*STANDARD HARDWARE -PURCHASE LOCALLY

# REPAIR PARTS

GT TWIN GARDEN TRACTOR – MODEL NUMBER 917.255919

ENGINE BRIGGS & STRATTON – MODEL NUMBER 422437, TYPE NUMBER 1256-01  
CYLINDER, CRANKSHAFT AND ENGINE BASE

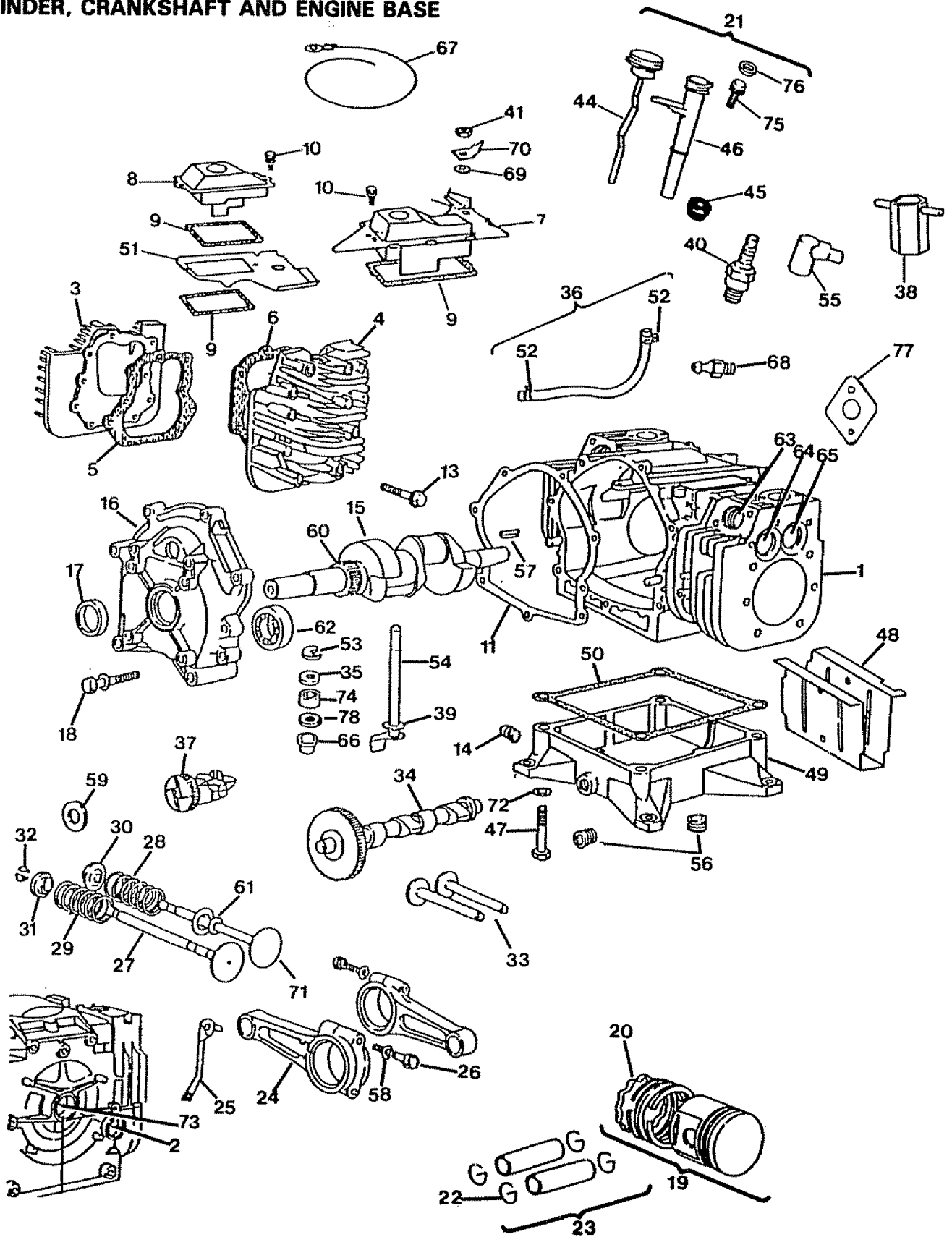

# REPAIR PARTS

## GT TWIN GARDEN TRACTOR – MODEL NUMBER 917.255919

### ENGINE BRIGGS & STRATTON – MODEL NUMBER 422437, TYPE NUMBER 1256-01

#### CYLINDER, CRANKSHAFT AND ENGINE BASE GROUP

KEY NO.	PART NO.	DESCRIPTION	KEY NO.	PART NO.	DESCRIPTION
01	491685	Cylinder Assembly	34	212337	Gear-Cam
02	391086	Seal-Oil	35	491287	Foam Seal - Governor Shaft
03	212461	Head-Cylinder No. 1	36	296004	Pipe - Fuel 23' cut to length
04	212462	Head-Cylinder No. 2	37	394348	Gear - Governor
05	271867	Gasket-Cylinder Head No. 1	38	89838	Wrench-Spark Plug
06	271868	Gasket-Cylinder Head No. 2	39	220863	Washer-Gov Crank (inside)
07	393243	Breather Assembly No. 1	40	394539	** Plug-Spark (Resistor) 2-3/8 high-60mm)
08	393153	Breather Assembly No. 2			Nut-Hex 8-32
09	27803	Gasket-Valve Cover	41	90576	
10	94382	Screw-Sem			
11	270982	Gasket-Crankcase Cover 1/64" Thick	44	398924	Cap and Dipstick-Oil Filter
11	271145	Gasket-Crankcase Cover 005" Thick	45	68838	Seal-Filter Tube
11	271146	Gasket-Crankcase Cover 009" Thick	46	280220	Tube - Oil Filter
13	93211	Screw-Cylinder Head (2-21/32" long)	47	93783	Screw-Hex Hd
14	91084	Plug-Oil Drain	48	223055	Trough-Dipper
15	394430	Crankshaft - order part 94196 Key for retaining timing gear	49	394391	Base-Engine
16	394535	Cover Assembly - Crankcase	50	270981	Gasket-Engine Base
17	291675	Seal-Oil	51	222700	Guide Air
18	93847	Screw-Crankcase cover Mtg Sem	52	93053	Clamp-Fuel Pipe
19	394955	Piston Assembly-Standard Inc Key No's 20 & 22)	53	94296	Retainer-E-Ring
19	394956	Piston Assembly - 010" O S	54	491530	Crank-Governor
19	394957	Piston Assembly - 020" O S	55	66538	Elbow-Spark Plug
19	394958	Piston Assembly - 030" O S	56	93448	Plug-Hex Socket
20	394959	Ring Set - Piston - Standard	57	222698	Key-Flywheel
20	394960	Ring Set - Piston - 010" O S	58	220863	Washer
20	394961	Ring Set - Piston - 020" O S	59	222773	Washer-Thrust
20	394962	Ring Set - Piston - 030" O S	60	231445	Gear-Timing
21	398990	Dipstick and Tube Assembly (Inc Key No's 44, 45 & 46)	61	393606	Seal Ass'y and Retainer
22	260924	Lock-Piston Pin	62	393741	Bearing-Ball (P T O side)
23	299691	Pin Assembly - Piston Standard (Inc. Key No 22)	63	261961	Guide-Exhaust Valve
23	391286	Pin - Assembly-Piston- 005" O S	64	210940	NOTE 231218 Intake Valve Guide Only (Brass)
24	394306	Rod Assembly-Connecting For Connecting Rod with 020" Crankpin bore order No 397158	65	210940	Seat-Exhaust Valve (Standard)
25	223053	Dipper-Connecting Rod	66	261463	Seat-Intake Valve (Standard)
26	92909	Screw-Connecting Rod	67	262332	Lower Bushing - Gov
27	390420	Valve-Exhaust	68	398808	Wire-Ground
28	65906	Spring-Intake Valve	69	230318	Connector-Fuel Pipe
29	26828	Spring-Exhaust Valve	70	92791	Washer-Lock Shakeproof
30	221596	Retainer-Intake Valve	71	93722	Terminal-Spade
31	292260	Rotocoil-Exhaust	72	261528	Valve-Intake
32	93630	Retainer-Exhaust Valve Roto-Cap	73	92268	Washer
33	261368	Tappet-Valve	74	491523	Bearing-Cylinder
			75	262331	Upper Bushing-Governor
			76	93886	Screw
			77	271170	Seal Tube
			78	271174	Gasket - Exhaust
				223882	Washer - Gov Shaft

\*INCLUDED IN GASKET SET 394501

+ SPECIAL TOOLS REQUIRED TO INSTALL

\*\* Use resistor plug, Champion RJ19LM or equivalent



# REPAIR PARTS

GT TWIN GARDEN TRACTOR – MODEL NUMBER 917.255919

ENGINE BRIGGS & STRATTON – MODEL NUMBER 422437, TYPE NUMBER 1256-01

## AIR CLEANER--CARBURETOR GROUP

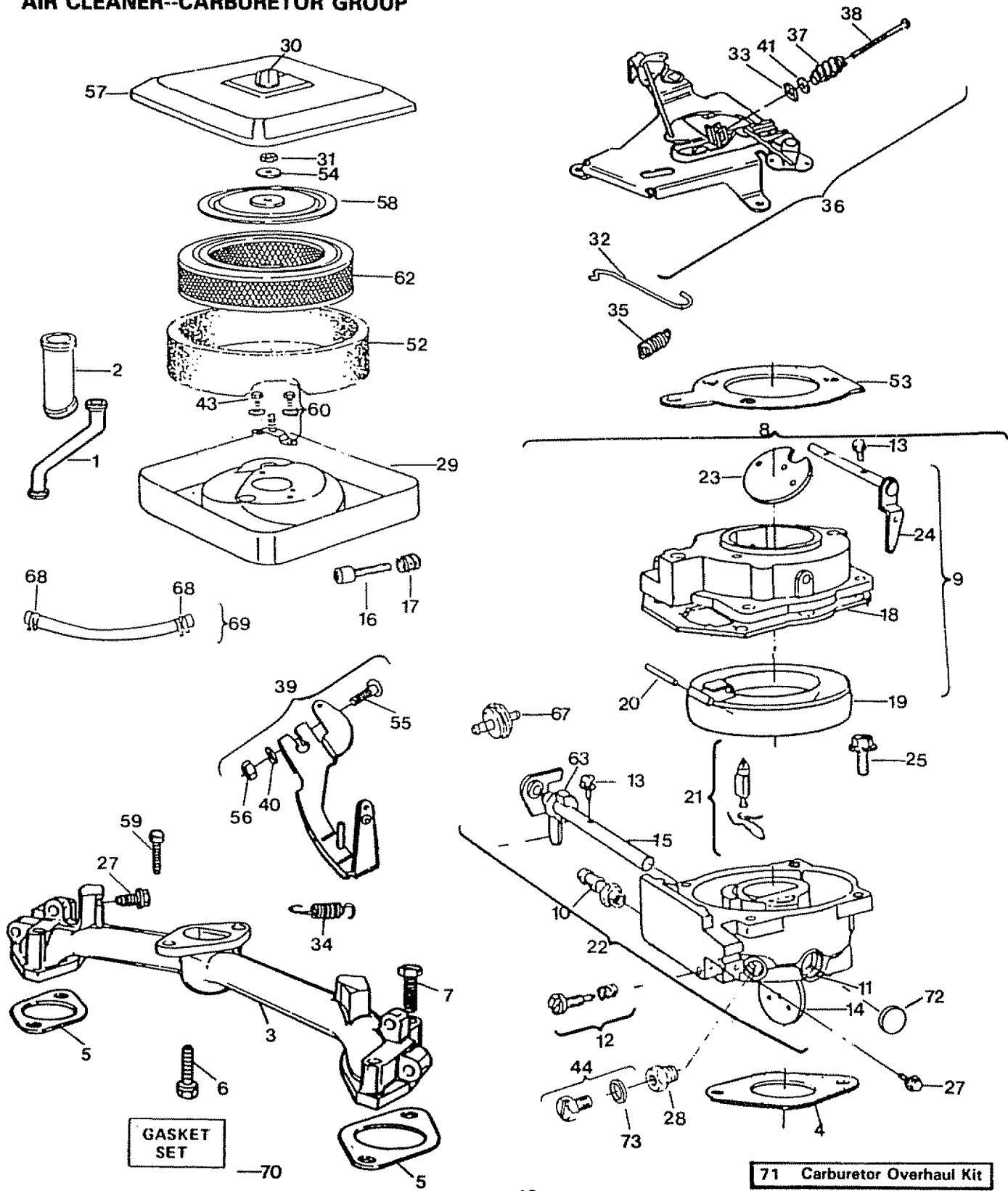

# REPAIR PARTS

GT TWIN GARDEN TRACTOR – MODEL NUMBER 917.255919

ENGINE BRIGGS & STRATTON – MODEL NUMBER 422437, TYPE NUMBER 1256-01

## AIR CLEANER--CARBURETOR GROUP

KEY NO.	PART NO.	DESCRIPTION	KEY NO.	PART NO.	DESCRIPTION
1	280819	Tube-Breather	31	93715	Nut-Hex
2	280198	Tube-Intake	32	262333	Link Governor
3	213288	Manifold Ass'y Intake	33	94298	Nut-Square
4	271412	+ *Gasket-Carb. Mtg.	34	262351	Spring-Governor
5	270884	Gasket-Intake Manifold Mtg.	35	251563	Spring - Governor Idle
6	93415	Screw Carb. MTG. Sem	36	491282	Bracket-Speed Control
7	94367	Screw Intake Manifold Mtg. Sem	37	262337	Spring-Compression
8	491630	Carburetor Ass'y (Inc Key No's 9. 10. 11. 12. 13. 14. 15. 16. 17. 18. 19. 20. 21. 22. 23. 24. 25. 28. 44. 46. 47. 48. 49. 50. 51. 61. 63. 64 & 65	38	94297	Screw Pan Head
			39	491298	Lever Ass'y Governor (Inc Key No's 40 55 & 56)
9	491541	Body Assembly - Upper Carburetor (Inc. Key No's 10, 13, 18. 23 & 24)	40	222289	Washer
			41	223882	Washer
10	230318	Connector - Fuel	43	93893	Screw-Sem
11	231209	Bushing-Throttle Shaft	44	397882	Plug (Inc Key No 73 )
12	491538	+ Valve Ass'y -Carb Idle	52	271271	Element-Air Cleaner
13	93499	Screw-Throttle and Choke Valve Mtg Sem	53	271411	+ Gasket-Air Cleaner
			54	271180	Washer
14	221939	Valve-Throttle	55	93853	Bolt-Governor Lever
15	392672	Shaft and Lever-Throttle	56	92278	Nut-Hex
16	91920	Screw-Mach Fil Hd 8-32 x 5/8	57	223001	Cover-Air Cleaner
17	26157	Spring - Throttle Adj	58	222835	Cartridge Plate-Air Cleaner
18	271607	+ *Gasket-Carburetor Body	59	93868	Screw-Sem
19	298514	Float-Carburetor Body	60	392643	Mounting Strap Ass'y Air Cleaner (Inc Key No 43)
20	230896	+ Pin-Float Hinge	62	394018	Cartridge-Air Cleaner
21	394681	+ Valve-Fuel Inlet	63	271013	+ Washer-Choke Shaft
22	491665	Body - Lower Carburetor (Inc. Key No's 11. 13. 14. 15 & 65)	67	394358	Filter-Fuel
			68	93053	Clamp-Fuel Pipe
23	223534	Valve-Choke	69	393815	Fuel-Line (cut to required length )
24	392673	Shaft and Lever-Choke	70	394501	Gasket Set
25	94152	Screw-Hex Head Sem 10/32 x 3/4	71	491539	Carburetor Overhaul Kit
27	93897	Screw-Casing Clamp	72	223472	Plug - Welch
28	231338	°Jet-Needle Valve	73	280474	O-Ring Seal
29	222752	Body-Air Cleaner			
30	212706	Knob-Air Cleaner			

\*INCLUDED IN GASKET SET  
 + INCLUDED IN CARBURETOR OVERHAUL KIT  
 °For high altitude - use jet # 231333



# REPAIR PARTS

GT TWIN GARDEN TRACTOR – MODEL NUMBER 917.255919

ENGINE BRIGGS & STRATTON – MODEL NUMBER 422437, TYPE NUMBER 1256-01

## STARTER MOTOR GROUP

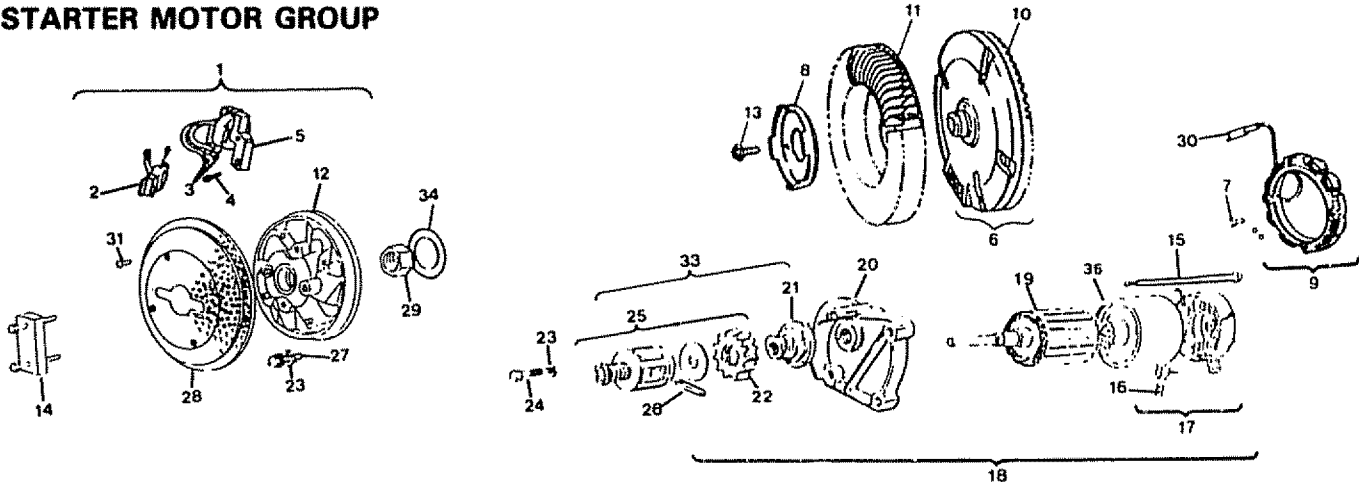

KEY NO.	PART NO.	DESCRIPTION	KEY NO.	PART NO.	DESCRIPTION
1	394891	Armature Group (Inc Key No's 2 3 & 5)	18	394808	Motor - Starting (Inc Key No's 13, 15, 16, 17, 19, 20, 21, 22, 23 & 24)
2	394970	Trigger Coil Assembly Magnatron Ignition	19	390837	Amature Assembly (Motor)
3	221798	Terminal - Ignition Cable	20	394860	Drive End Cap Ass'y - Starter
4	93381	Screw - Armature Mtg. Sem	21	398003	Clutch Ass'y
5	394988	Armature Ass'y	22	280104	Gear
6	491180	Flywheel and Ring Gear Ass'y - Magneto	23	90366	Lockwasher
7	93621	Screw - Sem	24	91162	Screw - Hex Hd - 5/16 - 18 x 1 - 1/2"
8	223726	Retainer-Fan	25	393254	Kit - Pinion Spring (Inc Key No's 22 & 26)
9	392595	Stator - Alternator	26	94192	Roll Pin
10	391362	Gear - Flywheel Ring (Includes Mounting Parts)	27	94385	Screw - Hex Hd
11	280815	Fan - Flywheel	28	223008	Screen - Rotating
12	213472	Fan - Booster	29	230674	Nut - Hex
13	93535	Screw-Sem	30	393537	Connector - Tri Circuit
14	19203	Puller - Flywheel (Optional Accessory)	31	93808	Screw-Sem
15	94003	Thru Bolt	33	396865	Starter Drive Group (Inc Key No's 21, 22, 25 & 26)
16	395538	Brush Set	34	222511	Washer - Spring
17	395537	Commutator End Cap Ass'y - Starter (Inc Key No 16)	35	393825	Housing Assembly

## MUFFLER, AIR GUIDE AND HOUSING GROUP

KEY NO.	PART NO.	DESCRIPTION
1	491243	Housing-Blower
2	93158	Screw - Sem
3	93777	Screw - Hex H
4	491444	Back Plate Assembly
5	222848	Cover - Air Guide
6	222846	Shield - Cylinder
7	93163	Screw - Sem
8	223734	Shield - Cylinder
9	222849	Cover - Air Guide

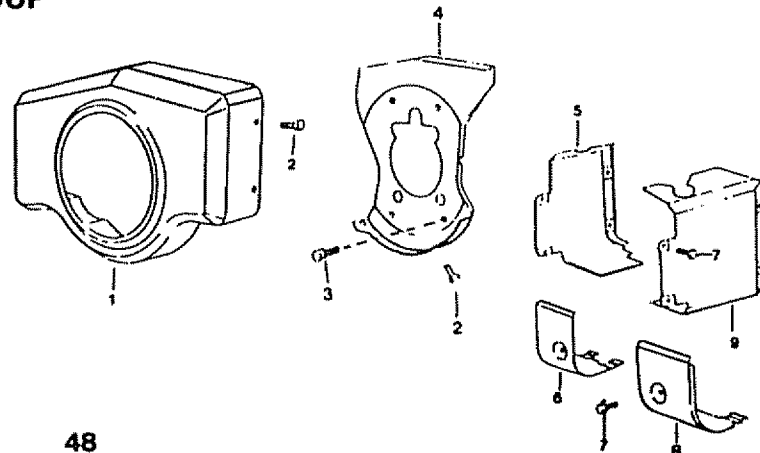

## Attachments That Add to the Usefulness of Your Craftsman Garden Tractor

Sears offers a wide variety of attachments that fit your tractor. Many of these are listed below with brief explanations of how they can help you. This list was current at the time of publication; however, it may change in future years — more attachments may be added, changes (including changes in the stock number) may be made in these attachments, or some may no longer be available.

Most of these attachments do not require additional hitches or conversion kits (those that do are indicated) and are designed for easy attaching and detaching. You may order these attachments at most Sears retail stores, catalog sales offices, and through the catalog.

**LAWN SWEEPERS** let you collect grass clippings and leaves.

Stock No.	Path	Capacity
71-24030	30-in.	9.0 cu. ft.
71-24032	32-in.	10.0 cu. ft.
71-24033 High-Performance	32 in.	11.5 cu. ft.
71-24038	38-in.	12.5 cu. ft.

**LAWN VACS** for powerful collections of heavy grass clippings and leaves. All acceptWand attachment to pick up debris in hard-to-reach places.

Stock No.	Engine	Capacity	Also Required
71-2455	3HP	8 bu.	71-26471 chute
71-2452	3HP	12 bu.	71-26471 chute
71-2447	5HP	25bu.	71-24474 chute 10 cu. ft. cart

**CARTS** make hauling easy.

Stock No.	Size	Capacity	
71-24353	4 cu. ft.	400 lb.	Dump cart
71-24354	10 cu. ft.	1,000 lb.	Hauling cart
71-24355	10 cu. ft.	1,000 lb.	Dump cart
71-24356	14 cu. ft.	1,250 lb.	Dump cart
71-24357	17 cu. ft.	1,500 lb.	Dump cart

**ROLLER** for smoother lawn surface. 36-inch wide, 18 inch diameter water-tight drum holds up to 390 lb. of weight. Rounded edges prevent harm to turf. Adjustable scraper automatically cleans drum. Stock number 71-24084.

**SPREADER/SEEDERS** make seeding, fertilizing, and weed killing easy. Broadcast spreaders are also useful for granular de-icers and sand.

71-24194	Drop type, 36 inch. 12 in. semi-pneumatic wheels. 100 lb. capacity steel hopper.
71-24394	Broadcasts over a 5 to 8 foot swath. 70 lb. capacity steel hopper. Noncorrosive spreading sp. inner, nylon gear box, stainless steel shaft.
71-24395	Broadcasts 8 to 10 foot swath. 160 lb. capacity.( covers 40,000sq. ft.)No-rust polypropylene hopper and impeller. Vinyl hopper cover.
71-2416	Broadcasts 6 to 8 foot swath. 50 lb. capacity. Corrosion-resistant construction. Polyethylene hopper.

**CORING AERATOR** takes small plugs out of soil to allow moisture and nutrients to reach grass roots. 36-inch swath. 24 hardened steel coring tips. 150 lb. capacity weight tray. Stock number 71-24351

**AERATOR** promotes deep root growth for a healthy lawn. Tapered 2.5" steel spikes mounted on 10-in. diameter discs puncture holes in soil at close intervals to let moisture soak it. Steel weight tray for increased penetration. Stock number 71-2435.

**DETHATCHER** loosens and flips thatch and matted leaves to lawn surface for easy pick up. Twenty spring tine teeth. Useful to prepare bare areas for reseeding. 40 inch rear mount: Stock number 71-24313. 38 inch front mount: Stock number 71-24301.

**SPRAYERS** use 12-volt DC electric motor that connects to the tractor battery or other 12-volt source. Includes booms for automatic spraying when pulling, and hand held wand for spot spraying. Wand has adjustable spray pattern. For applying herbicides, insecticides, fungicides, and liquid fertilizers.

71-2458 50 psi maximum pressure with 25 foot wand length. Sprays up to 25 feet with wand.

71-24398 25 psi maximum pressure with 18 foot wand length. Sprays up to 18 feet with wand.

**DOZER BLADE** removes snow; grades dirt, sand and gravel. 48 inches wide, 17 inches high, clears 44 inch path when angled. Master lift control lever for operator ease. Spring trip for snow removal on uneven pavement; built - in float for blade to follow ground contour. Reversible, replaceable scraper bar. (Use with tire chains, wheel weights or rear drawbar weight). Stock No. 71-24402

**SNOWTHROWER** has 42-inch swath. Drum-type auger handles powdery and wet/heavy snow. Mounts easily with simple pin arrangement. Discharge chute adjusts to 240 degree arc from tractor seat. 6-inch diameter spout discharges snow 10 to 50 ft. Lift controlled at tractor seat. (Use with tire chains, wheel weights, or rear drawbar weight). Stock No. 71-24074

**TIRE CHAINS** are heavy duty; closely spaced extra-large cross links give smooth ride, outstanding traction. Stock No. 71-26946.

**WHEEL WEIGHTS** provide stability, reduce tearing of turf when moving on hills, stopping, turning, starting. Provides extra weight for traction to pull low-loads, lawn vac. Required for snow removal. For plowing: one in front frame, one in right rear tire, two on left rear tire. For snow blower or dozer blade: one on right rear tire, one on left rear tire. 55 pounds. Stock No. 71-26234. (Front or rear mounting frame bracket Stock No. 71-26235.)

**CHEVRON TIRES** for extra traction. Pair of rear tires mounted on wheels. Stock No. 71-24167.

**TRACTOR CAB** has heavy duty vinyl fabric over tubular steel frame, fiberglass top; clear plastic windshield offers 360 degree visibility. Hinged metal frame doors with catch. Keeps operator warm and dry. Remove vinyl and windshield for use as sun protector in summer. Stock No. 71-24173.

Optional accessories for tractor cab: tinted/tempered solid safety glass wind shield with hand operated wiper (Stock No. 71-26168); 12-volt amber caution light for mounting on cab top (Stock No. 71-26169).

**TRACTOR COVER** protects tractor from weather. Made of Evolution 3 fabric (water-repellent, extremely breathable, light weight, soft, non-abrasive, pliable in all temperatures, durable, stain-tear-puncture resistant, will not shrink or stretch). Stock No. 71-24602.

\***TILLER** has 8hp engine to prepare seed beds, cultivate and compost garden residue. Chain-drive transmission. Six 11 inch dia., one piece heat-treated steel tines. Tills 30 inch path. (Requires sleeve hitch Stock No. 71-25231.) Stock No. 71-25249.

\***PLOW** turns soil 6 inches deep, cuts 10 inch furrow. Crank adjustment controls depth, 3-position yoke sets width. Heavy steel landslide for straight forrowing. Stock No. 71-24233.

\***DISC HARROW** has 2 gangs of 4 steel blades that angle from 10 to 20 degrees 40 inches wide. Can hook 2 units in tandem. Stock No. 71-24234.

\***REAR GRADER/LEVELER BLADE** is 42-inches wide operated from driver's seat. Reversible steel blade can be angled at 30 degrees for grading. Reverses for snow plowing. Stock No. 71-24239.

\***SLEEVE CULTIVATOR** is 43 inches wide. Prepares ground for seeding, helps weed control. Steel frame holds 5 adjustable sweeps. Adjusts vertically, horizontally, Stock No. 71-25304. Optional accessory for cultivator: steel furrow opener for wider for wide openings for potatoes, corn, and other deep seeded crops (Stock No. 71-25305).

**ELECTRICAL ASSIST KIT** mounts to master lift. Raises and lowers front, mid, and rear mount attachments with flip of switch. Stock No. 71-25242.

\*Asterisked attachments require sleeve hitch (Stock No. 71-25231) for use with master lift system. Single pin couples/uncouples.

# SUGGESTED GUIDE FOR SIGHTING SLOPES FOR SAFE OPERATION

ONLY RIDE UP AND DOWN HILL  
NOT ACROSS HILL

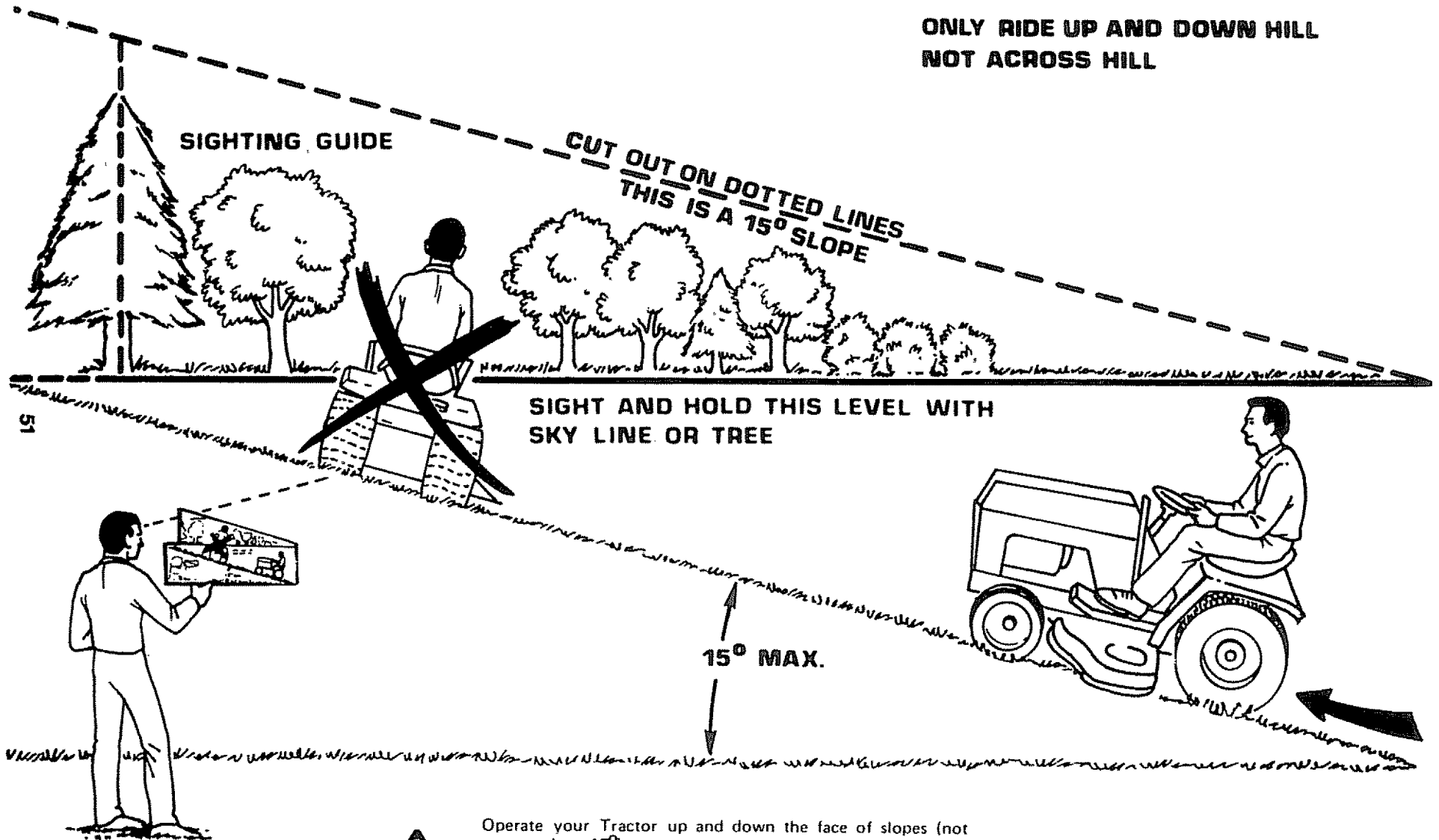

Operate your Tractor up and down the face of slopes (not greater than 15°); never across the face. Make turns gradually to prevent tipping or loss of control. Exercise extreme caution when changing direction on slopes.

**SEARS**

**OWNERS  
MANUAL**

**MODEL NO.  
917.255919**

**HOW TO ORDER  
REPAIR PARTS**

**CRAFTSMAN  
GT 18HP TWIN  
6 SPEED - 44" MOWER  
GARDEN TRACTOR**

*The Model Number will be found on the Model Plate located under the seat. Always provide the Model Number when requesting service or repair parts for your Garden Tractor.*

*All parts listed herein may be ordered from any Sears Service Center/Departments and most Sears Stores.*

**WHEN ORDERING REPAIR PARTS, ALWAYS GIVE THE FOLLOWING INFORMATION:**

- THE PART NUMBER
- THE PART DESCRIPTION
- THE MODEL NUMBER
- THE NAME OF MERCHANDISE

Your Sears merchandise has added value when you consider Sears has service units nationwide staffed with Sears trained technicians having the parts, tools and the equipment to insure that we meet our pledge to you, "We Service What We Sell".

Sears, Roebuck and Co. Chicago, IL 60684 U.S.A.

123611X0E 3.10.89  
Printed in U.S.A.