

Operator's Manual

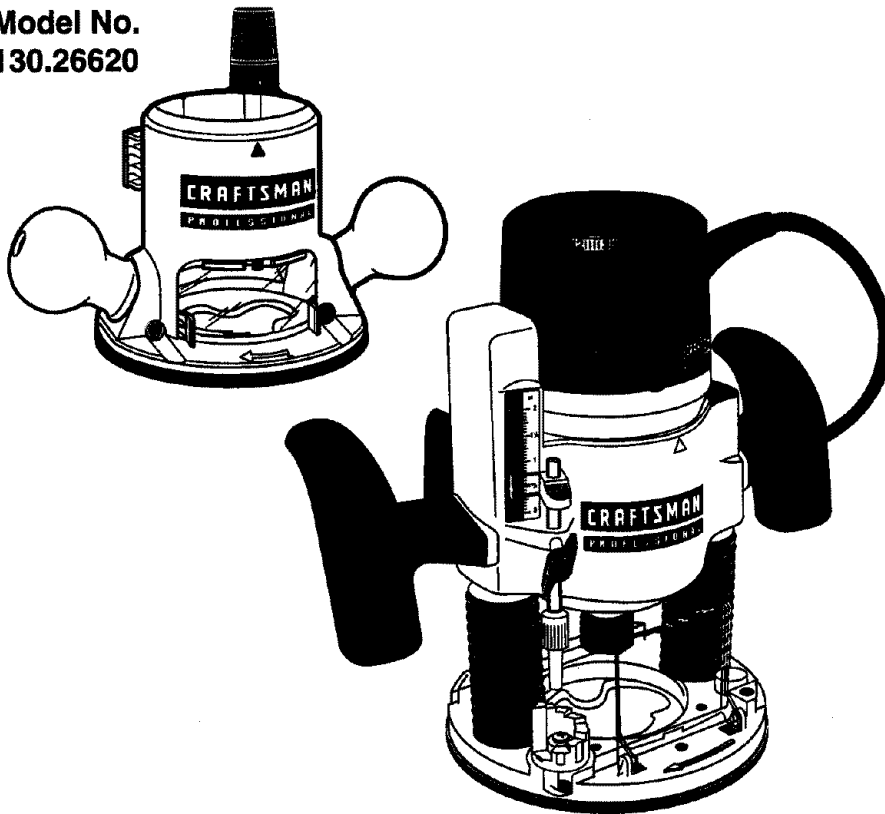

Fixed Base/Plunge Base Router Kit

Model No.
130.26620



CAUTION: Read, understand and follow all Safety Rules and Operating Instructions in this manual before using this product.

- SAFETY
- OPERATION
- MAINTENANCE
- ESPAÑOL

Sears, Roebuck and Co., Hoffman Estates, IL 60179 U.S.A.

Table of Contents

Warranty.....	Page 2
Safety Instructions.....	Pages 3 - 5
Safety Symbols.....	Page 6
Functional Description and Specifications.....	Pages 7 - 8
Assembly.....	Pages 9 - 11
Operating Instructions.....	Pages 12 - 19
Maintenance.....	Page 20
Accessories.....	Page 20
Repair Parts.....	Pages 21 - 23
Service Numbers.....	Back Cover

Warranty

ONE FULL YEAR WARRANTY ON CRAFTSMAN PROFESSIONAL TOOL

If this Craftsman Tool fails to give complete satisfaction within one year from the date of purchase, **RETURN IT TO THE NEAREST SEARS STORE OR SEARS PARTS & REPAIR CENTER IN THE UNITED STATES**, and Sears will repair it, free of charge.

This warranty gives you specific legal rights, and you may also have other rights which vary from state to state.

Sears, Roebuck and Co. Dept. 817 WA, Hoffman Estates, IL 60179

**SAVE THESE INSTRUCTIONS!
READ ALL INSTRUCTIONS!**

Power Tool Safety Rules



WARNING

Read and understand all instructions. Failure to follow all instructions listed below, may result in electric shock, fire and/or serious personal injury.

SAVE THESE INSTRUCTIONS

Work Area

Keep your work area clean and well lit. Cluttered benches and dark areas invite accidents.

Do not operate power tools in explosive atmospheres, such as in the presence of flammable liquids, gases, or dust. Power tools create sparks which may ignite the dust or fumes.

Keep by-standers, children, and visitors away while operating a power tool. Distractions can cause you to lose control.

Electrical Safety

Double Insulated tools are equipped with a polarized plug (one blade is wider than the other.) This plug will fit in a polarized outlet only one way. If the plug does not fit fully in the outlet, reverse the plug. If it still does not fit, contact a qualified electrician to install a polarized outlet. Do not change the plug in any way. Double Insulation  eliminates the need for the three wire grounded power cord and grounded power supply system. *Before plugging in the tool, be certain the outlet voltage supplied is within the voltage marked on the nameplate. Do not use "AC only" rated tools with a DC power supply.* **Avoid body contact with grounded surfaces such as pipes, radiators, ranges and refrigerators.** There is an increased risk of electric shock if your body is grounded. If operating the power tool in damp locations is unavoidable, a Ground Fault Circuit Interrupter must be used to supply the power to your tool. Electrician's rubber gloves and footwear will further enhance your personal safety.

Don't expose power tools to rain or wet conditions. Water entering a power tool will increase the risk of electric shock.

Do not abuse the cord. Never use the cord to carry the tools or pull the plug from an outlet. Keep cord away from heat, oil, sharp edges or moving parts. Replace damaged cords immediately. Damaged cords increase the risk of electric shock.

When operating a power tool outside, use an outdoor extension cord marked "W-A" or "W." These cords are rated for outdoor use and

reduce the risk of electric shock. Refer to "Recommended sizes of Extension Cords" in the Accessory section of this manual.

Personal Safety

Stay alert, watch what you are doing and use common sense when operating a power tool. Do not use tool while tired or under the influence of drugs, alcohol, or medication. moment of inattention while operating power tools may result in serious personal injury.

Dress properly. Do not wear loose clothing or jewelry. Contain long hair. Keep your hair, clothing, and gloves away from moving parts. Loose clothes, jewelry, or long hair can be caught in moving parts. Keep handles dry, clean and free from oil and grease.

Avoid accidental starting. Be sure switch is "OFF" before plugging in. Carrying tools with your finger on the switch or plugging in tools that have the switch "ON" invites accidents.

Remove adjusting keys or wrenches before turning the tool "ON". A wrench or a key that is left attached to a rotating part of the tool may result in personal injury. **Do not overreach.**

Keep proper footing and balance at all times. Proper footing and balance enables better control of the tool in unexpected situations.

Use safety equipment. Always wear eye protection. Dust mask, non-skid safety shoes, hard hat, or hearing protection must be used for appropriate conditions.

Tool Use and Care

Use clamps or other practical way to secure and support the workpiece to a stable platform. Holding the work by hand or against your body is unstable and may lead to loss of control.

Do not force tool. Use the correct tool for your application. The correct tool will do the job better and safer at the rate for which it is designed.

Do not use tool if switch does not turn it "ON" or "OFF". Any tool that cannot be controlled with the switch is dangerous and must be repaired.

Power Tool Safety Rules

Disconnect the plug from the power source before making any adjustments, changing accessories, or storing the tool. Such preventive safety measures reduce the risk of starting the tool accidentally.

Store idle tools out of reach of children and other untrained persons. Tools are dangerous in the hands of untrained users.

Maintain tools with care. Keep cutting tools sharp and clean. Properly maintained tools, with sharp cutting edges are less likely to bind and are easier to control. Any alteration or modification is a misuse and may result in a dangerous condition.

Check for misalignment or binding of moving parts, breakage of parts, and any other condition that may affect the tool's operation. If damaged, have the tool serviced before using. Many accidents are caused by poorly maintained tools. Develop a periodic maintenance schedule for your tool.

Use only accessories that are sold at Sears for your model. Accessories that may be suitable for one tool, may become hazardous when used on another tool.

Service

Tool service must be performed only by qualified repair personnel. Service or maintenance performed by unqualified personnel could result in a risk of injury. For example: internal wires may be misplaced or pinched, safety guard return springs may be improperly mounted.

When servicing a tool, use only identical replacement parts. Follow instructions in the Maintenance section of this manual.

Unauthorized parts or failure to follow Maintenance Instructions may create a risk of electric shock or injury. Certain cleaning agents such as gasoline, carbon tetrachloride, ammonia, etc. may damage plastic parts.

Safety Rules for Routers

Hold tool by insulated gripping surfaces when performing an operation where the cutting tool may contact hidden wiring or its own cord. Contact with a "live" wire will make exposed metal parts of the tool "live" and shock the operator. *If cutting into existing walls or other blind areas where electrical wiring may exist is unavoidable, disconnect all fuses or circuit breakers feeding this worksite.*

Always make sure the work surface is free from nails and other foreign objects. Cutting into a nail can cause the bit and the tool to jump and damage the bit.

Never hold the workpiece in one hand and the tool in the other hand when in use. Never place hands near or below cutting surface. Clamping the material and guiding the tool with both hands is safer.

Never lay workpiece on top of hard surfaces, like concrete, stone, etc... Protruding cutting bit may cause tool to jump.

Always wear safety goggles and dust mask. Use only in well ventilated area. Using personal safety devices and working in safe environment reduces risk of injury.

After changing the bits or making any adjustments, make sure the collet nut and any other adjustment devices are securely tightened. Loose adjustment device can unexpectedly shift, causing loss of control, loose rotating components will be violently thrown.

Never start the tool when the bit is engaged in the material. The bit cutting edge may grab the material causing loss of control of the cutter.

Always hold the tool with two hands during start-up. The reaction torque of the motor can cause the tool to twist.

The direction of feeding the bit into the material is very important and it relates to the direction of bit rotation. When viewing the tool from the top, the bit rotates clockwise. Feed direction of cutting must be counter-clockwise. NOTE: Inside and outside cuts will require different feed direction, refer to section on feeding the router. Feeding the tool in the wrong direction, causes the cutting edge of the bit to climb out of the work and pull the tool in the direction of this feed.

Safety Rules for Routers cont.

Never use dull or damaged bits. Sharp bits must be handled with care. Damaged bits can snap during use. Dull bits require more force to push the tool, possibly causing the bit to break.

Never touch the bit during or immediately after the use. After use the bit is too hot to be touched by bare hands.

Never lay the tool down until the motor has come to a complete standstill. The spinning bit can grab the surface and pull the tool out of your control.

Never use bits that have a cutting diameter greater than the opening in the base.









⚠ WARNING Some dust created by power sanding, sawing, grinding, drilling, and other construction activities contains chemicals known to cause cancer, birth defects or other reproductive harm. Some examples of these chemicals are:

- Lead from lead-based paints,
- Crystalline silica from bricks and cement and other masonry products, and
- Arsenic and chromium from chemically-treated lumber.

Your risk from these exposures varies, depending on how often you do this type of work. To reduce your exposure to these chemicals: work in a well ventilated area, and work with approved safety equipment, such as those dust masks that are specially designed to filter out microscopic particles.

Symbols

IMPORTANT: Some of the following symbols may be used on your tool. Please study them and learn their meaning. Proper interpretation of these symbols will allow you to operate the tool better and safer.

Symbol	Name	Designation/Explanation
V	Volts	Voltage (potential)
A	Amperes	Current
Hz	Hertz	Frequency (cycles per second)
W	Watt	Power
kg	Kilograms	Weight
min	Minutes	Time
s	Seconds	Time
∅	Diameter	Size of drill bits, grinding wheels, etc.
n_0	No load speed	Rotational speed, at no load
.../min	Revolutions or reciprocation per minute	Revolutions, strokes, surface speed, orbits etc. per minute
0	Off position	Zero speed, zero torque...
1, 2, 3, ... I, II, III,	Selector settings	Speed, torque or position settings. Higher number means greater speed
	Infinitely variable selector with off	Speed is increasing from 0 setting
	Arrow	Action in the direction of arrow
	Alternating current	Type or a characteristic of current
	Direct current	Type or a characteristic of current
	Alternating or direct current	Type or a characteristic of current
	Class II construction	Designates Double Insulated Construction tools.
	Earthing terminal	Grounding terminal
	Warning symbol	Alerts user to warning messages
	Ni-Cad RBRC seal	Designates Ni-Cad battery recycling program



This symbol designates that this tool is listed by Underwriters Laboratories.



This symbol designates that this tool is listed to Canadian Standards by Underwriters Laboratories.



This symbol designates that this tool complies to NOM Mexican Standards.



This symbol designates that this tool is listed by the Canadian Standards Association.



Functional Description and Specifications

⚠ WARNING Disconnect the plug from the power source before making any assembly, adjustments or changing accessories. Such preventive safety measures reduce the risk of starting the tool accidentally.

Fixed Base with Motor Housing

FIG. 1

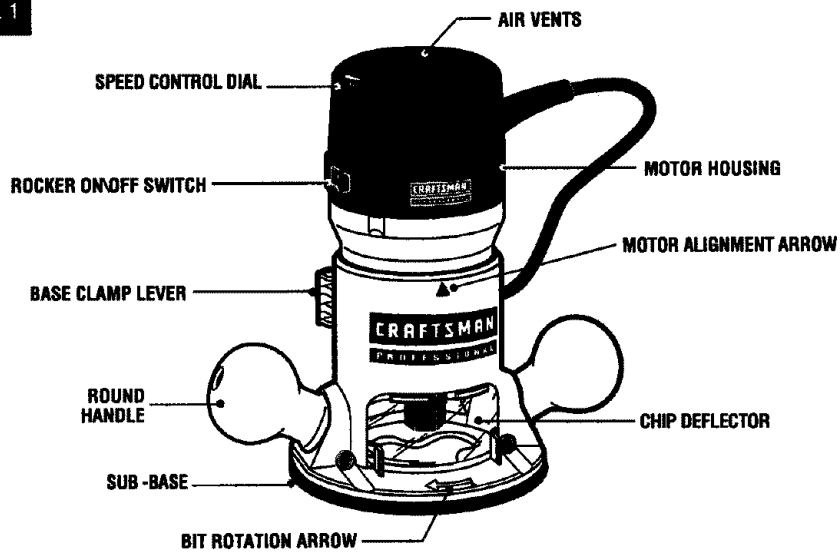

Specifications

Voltage rating	120V ~ 50 - 60Hz
Amperage rating	12A
No load speed	n_0 8,000 - 25,000/min
Collet capacities	1/4", 1/2"

Functional Description and Specifications cont.

WARNING Disconnect the plug from the power source before making any assembly, adjustments or changing accessories. Such preventive safety measures reduce the risk of starting the tool accidentally.

Plunge Base with Motor Housing

FIG 2

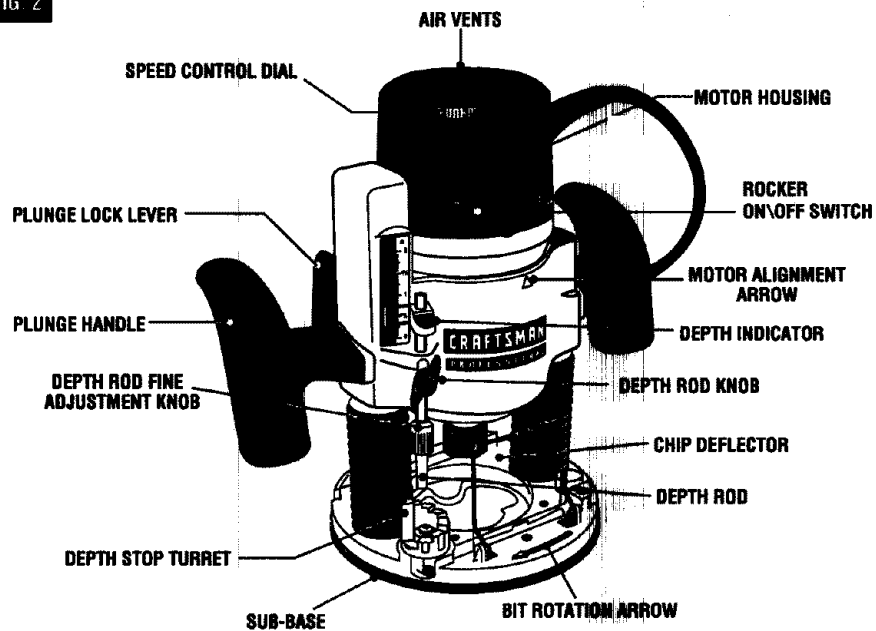

Specifications

Voltage rating	120V ~ 50 - 60Hz
Amperage rating	12A
No load speed	n ₀ 8,000 - 25,000/min
Collet capacities	1/4", 1/2"

Assembly

A wide assortment of router bits with different profiles is available separately. Use 1/2" shank whenever possible, and only use good quality bits.

⚠ WARNING To prevent personal injury, always remove the plug from power source before removing or installing bits or accessories.

INSTALLING A ROUTER BIT

Place router upside down or lay router on its side with the base resting on the bench. Another option is to remove the motor from the base before installing the bit.

1. Remove the chip shield (or flip up if plunge base is attached).
2. Hold the armature shaft in place with the shaft wrench (Fig. 3)
3. Next, use the collet wrench to loosen the collet chuck assembly in counter-clockwise direction (viewed from under the router).
4. Insert the shank of the router bit into the collet chuck assembly as far as it will go, then back the shank out until the cutters are approximately 1/8" to 1/4" away from the collet nut face.
5. With the router bit inserted and the shaft wrench holding the armature shaft, use the collet wrench to firmly tighten the collet chuck assembly in a clockwise direction (viewed from under the router). To ensure proper gripping of the router bit and minimize run-out, the shank of the router bit must be inserted at least 5/8".

FIG. 3

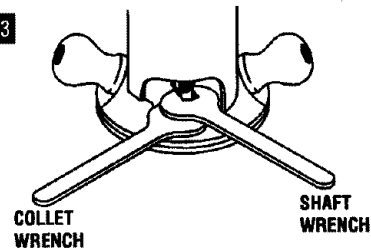

⚠ WARNING When the template guide has been removed from base, do not use router bits greater than 1 5/8" in diameter as they will not fit through the sub-base.

⚠ CAUTION To prevent damage to tool, do not tighten collet without a bit.

NOTE: The bit shank and chuck should be clean and free of dust, wood, residue and grease before assembling.

REMOVING THE ROUTER BIT

1. Use the shaft and collet chuck wrenches as described earlier, and turn the collet chuck assembly in a counter-clockwise direction.
2. Once the collet chuck assembly is loosened continue to turn the collet chuck assembly until it pulls the collet free from its taper, and the router bit can be removed.

NOTE: The collet chuck is self-extracting; it is NOT necessary to strike the collet chuck to free the router bit.

COLLET CHUCK CARE

With the router bit removed, continue to turn the collet chuck counter-clockwise until it is free of the shaft. To assure a firm grip, occasionally blow out the collet chuck with compressed air, and clean the taper in the armature assembly shaft with a tissue or fine brush.

The collet chuck is made up of two component parts as illustrated (Fig. 4); check to see that the collet is properly seated in the collet chuck nut and lightly thread the collet chuck back onto the armature shaft. Replace worn or damaged collet chucks immediately.

FIG. 4

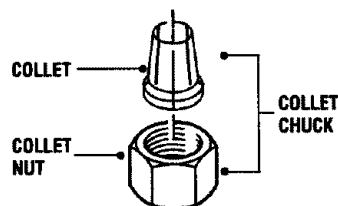

Assembly cont.

REMOVING MOTOR FROM BASE

To remove motor from fixed base: (Fig. 5)

1. Hold router in horizontal position, open base clamp lever, depress coarse adjustment lever, and pull motor upwards until it stops.
2. Turn motor counter-clockwise, and gently pull it free of base.

To remove motor from plunge base: (Fig. 6)

1. Hold router in horizontal position, open base clamp lever, and pull motor upwards until it stops.
2. Turn motor counter-clockwise, and gently pull it free of base.

INSTALLING MOTOR IN BASES

The motor can be installed with the switch positioned on the right or left of the base from the operator's side (and the cord facing the opposite side of the router). Install the motor so that the switch is in the location you find to be the most easily accessible from the handles. The switch should be easier to turn "OFF" than "ON" in case of an emergency.

To install motor in fixed base:

1. Release the base clamp lever.
2. Line up the arrow on the base with arrow on the motor. (Fig. 7)
 - To position switch on the right side of the base, line up the base's arrow with motor housing's arrow that is below the cord.
 - To position switch on the left, line up the base's arrow with motor housing's arrow that is below the switch.
3. While pressing the coarse adjustment lever, slide motor into base until resistance in felt. (The base's guide pin is now engaged into slot on motor.)
4. Continue to press coarse adjustment lever, and turn the motor clockwise until it stops.
5. Push the motor into the base until it reaches the approximate desired depth.
6. Release the coarse adjustment lever and slide the motor forward or back as needed until the coarse adjustment system's "catch" springs into the coarse adjustment detent notch.
7. Set final height position as described in "Operating Instructions".

FIG. 5

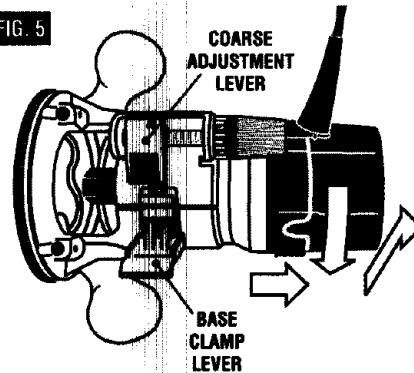

FIG. 6

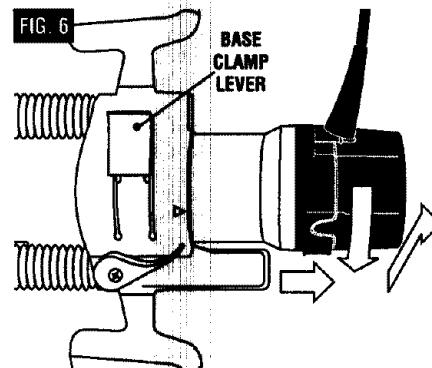
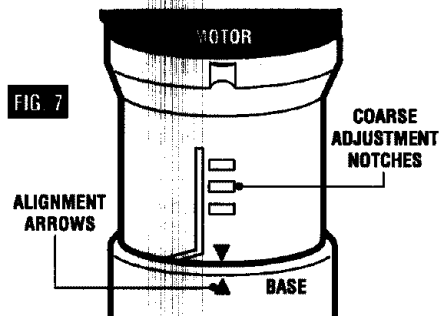

FIG. 7



Fixed Base

Assembly cont.

INSTALLING MOTOR IN BASES cont.

To install motor in plunge base:

1. Release the base clamp lever.
2. Line up the arrow on the base with arrow on the motor. (Fig. 8)
 - To position switch on the right side of the base, line up the base's arrow with arrow on the motor housing that is below the cord.
 - To position switch on the left, line up the base's arrow with arrow on the motor housing that is below the switch.
3. Slide motor into base until resistance is felt. (The base's guide pin is now engaged into slot on motor.)
4. Turn the motor clockwise until it stops.
5. Push the motor into the base as far as it will go.
6. Fasten the base clamp lever.

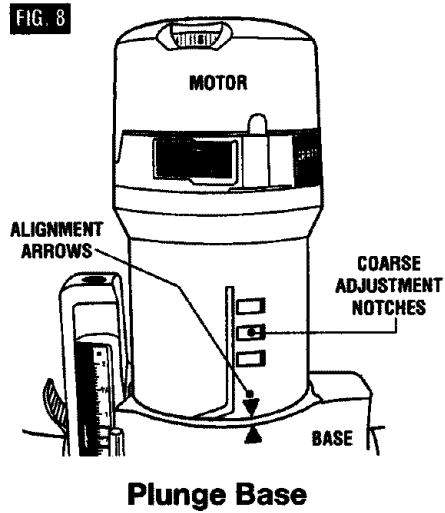

CHIP DEFLECTOR

WARNING Always wear eye protection. The chip deflector is not intended as a safety guard.

The chip deflectors help keep dust and chips out of your face; it will not stop objects larger than chips thrown from the bit.

To remove chip deflector shield from fixed base, press inward on tabs **A** Fig. 9, until it releases from base and remove. To install follow same directions, and snap back in position. The plunge base chip deflector shield **B** Fig. 10, can be flipped down and back up.

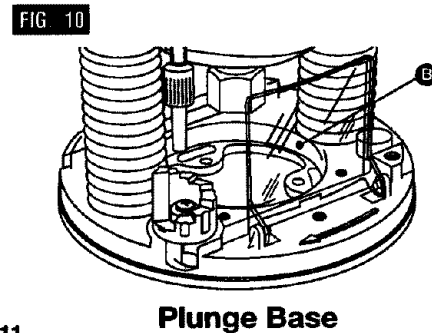
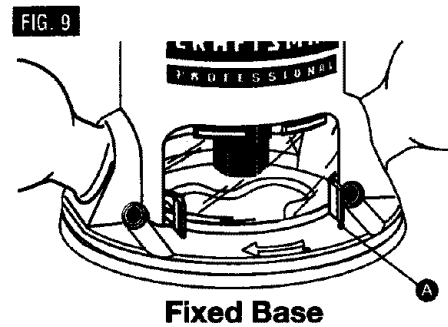

Operating Instructions

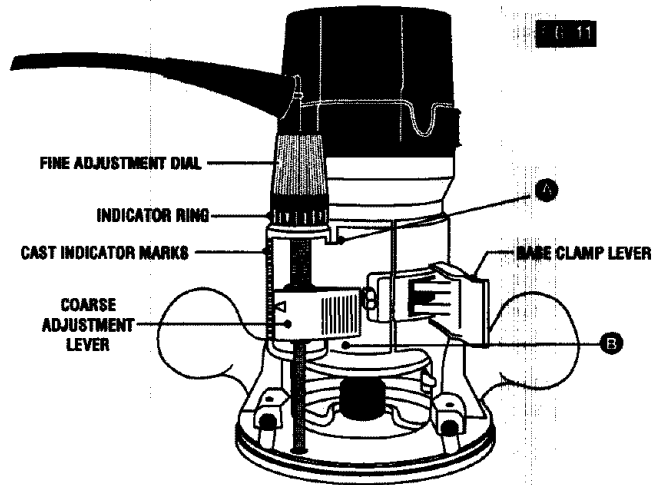

Fixed Base with Motor Housing

This router is designed for speed, accuracy and convenience in performing cabinet work, routing, fluting, beading, cove-cutting, dove tails, etc. It will enable you to accomplish inlay work, decorative edges and many types of special carving.

DEPTH ADJUSTMENT WITH FIXED BASE

Your router is equipped with a true micrometer type fine adjustment mechanism, which can be used in any position and provides precise adjustment of the router bit position for unmatched accuracy. When the tool is lowered to the approximate position desired, this device may be adjusted to precisely set the final bit position.

Your router also features three horizontal notches on both sides of the motor housing for coarse adjustments. The notches are spaced 1/2" apart which allows you to quickly lower or raise the tool depth in three 1/2" increments, approximately 12.7 mm, by simply depressing the coarse adjustment release lever.

TO ADJUST DEPTH

NOTE: All depth adjustments must be made with the base clamp lever released.

1. Hold the tool in a horizontal position with the base clamp lever facing you.
2. Open the base clamp lever to release the motor.

3. COARSE ADJUSTMENT:

To make a large depth adjustment, depress coarse adjustment release lever and raise or lower to desired depth. The 3 horizontal notches in the motor housing are spaced 1/2" apart to make this adjustment easier.

4. FINE DEPTH ADJUSTMENT:

To use the fine adjustment feature, turn the fine adjustment knob clockwise to lower the router bit or counter-clockwise to raise it.

NOTE: Be sure coarse adjustment lever is engaged in one of the coarse adjustment notches before making a fine adjustment.

To allow precise settings, the indicator ring is graduated in English and Metric increments. (Note: one full turn of fine adjustment knob = 1/16" or approximately 1.5 mm. The fine adjustment mechanism has a total adjustment range of 7/8" (23 mm). Each cast indicator mark next to coarse adjustment lever is equal to 1/8" To prevent damage to tool, avoid wedging the coarse adjustment lever against the upper **A** or lower **B** portion of the housing as shown in Figure 11.

5. After making depth adjustments, re-clamp the motor.

The indicator ring may be reset to zero without moving the fine adjustment knob, to allow the user to begin the adjustment from any reference point desired.

Operating Instructions cont.

TO CLAMP MOTOR

When final coarse and fine adjustments have been made, fasten the base clamp lever to secure adjustments. (If additional clamping force is desired: using a 10 mm wrench, rotate clamp nut clockwise **SLIGHTLY** (1/8 turn or less), then test clamp. Do not over-tighten.)

DEPTH ADJUSTMENT WITH PLUNGE BASE

PLUNGING ACTION

The plunge feature simplifies depth adjustments and will allow the cutting bit to easily and accurately enter the workpiece. To lower, push plunge lock lever to the left, apply downward pressure until you reach desired depth, and release pressure on lever to lock (Fig. 12). The plunge lock lever is spring loaded and returns automatically to the locked position. To raise the router, push plunge lock lever to the left, release pressure on router and the router will automatically retract the bit from the workpiece. It is advisable to retract the bit whenever it is not engaged in workpiece.

DEPTH ROD AND TURRET

The depth rod and the depth stop turret are used to control cutting depth as follows:

1. With the bit installed, gently lower the motor until the tip of the router bit just contacts the level surface the router is sitting on. This is the "zero" position, from which further depth adjustments can be accurately made.
2. To set a desired depth of cut, rotate depth stop turret until the lowest step is aligned with the depth rod. Loosen depth indicator knob and lower the depth rod until it contacts the lowest step of the turret. Slide the depth indicator until the red line indicates zero on the depth scale, indicating the point at which the bit just contacts the work (Fig. 12).
3. To set a desired cutting depth, slide the depth rod up until the red depth indicator line attains the desired cutting depth, and secure the rod in position by firmly tightening the depth indicator knob.

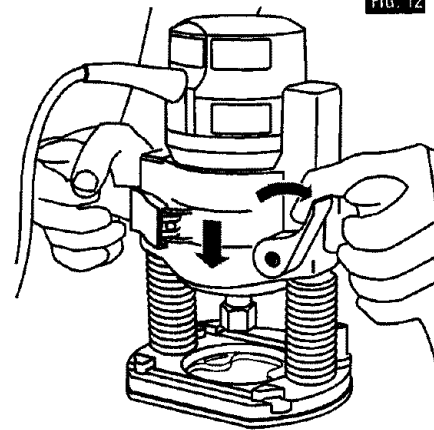

4. The desired depth of cut may now be achieved by plunging the router until the depth rod contacts the selected stop on the turret.

DEEP CUTS

For deeper cuts, make several progressively deeper cuts by starting with the highest step on the depth turret, and after each cut, rotate the depth turret to progressively lower steps as desired, until the final depth (lowest step or flat) is reached. Steps progress by 1/8" increments. To be certain that your depth settings are as desired, you may want to make test cuts in scrap material before beginning work.

FIG 13

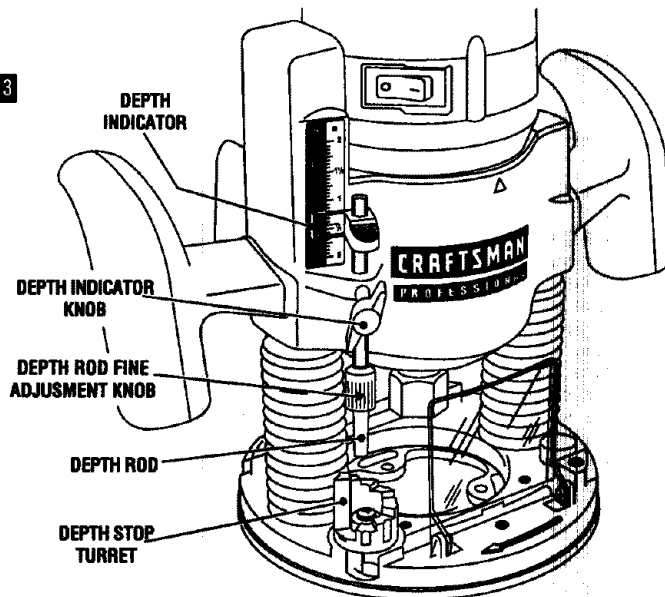

FINE ADJUSTMENT

The plunge base is equipped with a fine adjustment system that allows you to micro adjust the plunge depth of the router bit for superior routing accuracy.

Each complete revolution of the fine adjustment stop adjusts the plunging depth by $1/32"$, and each of the four indicator marks on the knob represents $1/128"$. One of the four tick marks is larger than the other to indicate a complete revolution. A reference indicator line is built in to the depth rod.

To use the fine adjustment knob, once the depth rod and turret have been set, check the final depth setting and fine-adjust as follows:

1. To micro-increase the plunge depth, raise the fine adjustment stop by turning it counter-clockwise by the desired amount.

2. To micro-reduce the plunge depth, lower the fine adjustment stop by turning it clockwise by the desired amount.

Notes:

- When micro-adjusting the plunge depth, it is more convenient to move the fine adjustment stop up than down. Before setting the depth rod and turret, make sure the fine adjustment stop has been turned several revolutions down from its top position so that it can be adjusted upward.
- The fine adjustment stop cannot be used to reduce the plunge depth when the depth rod is already touching the depth stop turret. The router must be raised before such an adjustment can be made.

Operating Instructions cont.

ROCKER "ON/OFF" SWITCH

Your tool can be turned "ON" or "OFF" by the rocker switch located on the motor housing. One side of the switch is marked "I" for "ON", and the other side of switch is marked "O" for "OFF". Also the edge of switch displays red when switch is in the "ON" position.

TO TURN THE TOOL "ON": Push the side of the switch marked "I".

TO TURN THE TOOL "OFF": Push the side of the switch marked "O".

Always hold the router off the work when turning the switch on or off. Contact the work with the router after the router has reached full speed, and remove it from the work before turning the switch off. Operating in this manner will prolong switch and motor life and will greatly increase the quality of your work.

SOFT START FEATURE

Electronic feedback control minimizes torque twist customary in larger routers by limiting the speed at which motor starts.

ELECTRONIC VARIABLE SPEED CONTROL

The electronic speed control feature allows motor speed to be matched to cutter size and material hardness for improved finish, extended bit life, and higher performance. Speed changes are achieved by rotating Control Dial RIGHT to increase speed, LEFT to decrease as indicated on housing. Speed may be changed while tool is on. The reference numbers on the dial facilitate re-setting control to desired speed.

The speed chart indicates the relationship between settings and application, exact settings are determined by operator experience and preference. The bit manufacturer may also have a speed recommendation.

DIAL SETTING	RPM	APPLICATION
1	8,000	} Nonferrous metals, larger diameter bits, and cutters
2	13,500	
3	16,500	
4	20,000	} Softwoods, plastics, counter tops, smaller diameter bits, and cutters
5	21,500	
6	25,000	

ELECTRONIC FEEDBACK CIRCUITRY

The router's Electronic Feedback Circuitry monitors and adjusts power to maintain the desired RPM for consistent performance and control.

Operating Instructions

FEEDING THE ROUTER

As seen from the top of the router, the bit turns clockwise and the cutting edges face accordingly. Therefore, the most efficient cut is made by feeding the router so that the bit turns into the work, not away. Figure 14 shows proper feed for various cuts. How fast you feed depends on the hardness of the material and the size of the cut. For some materials, it is best to make several cuts of increasing depth.

If the router is hard to control, heats up, runs very slowly or leaves an imperfect cut, consider these causes:

1. Wrong direction of feed — hard to control.
2. Feeding too fast — overloads motor.
3. Dull bit — overloads motor.
4. Cut is too large for one pass — overloads motor.
5. Feeding too slow — leaves friction burns on work.

Feed smoothly and steadily (do not force). You will soon learn how the router sounds and feels when it is working best.

FIG. 14

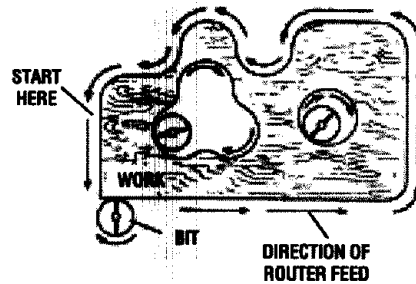

RATE OF FEED

When routing or doing related work in wood and plastics, the best finishes will result if the depth of cut and feed rate are regulated to keep the motor operating at high speed. Feed the router at a moderate rate. Soft materials require a faster feed rate than hard materials.

The router may stall if improperly used or overloaded. Reduce the feed rate to prevent possible damage to the tool. Always be sure the collet chuck is tightened securely before use. Always use router bits with the shortest cutting length necessary to produce the desired cut. This will minimize router bit run-out and chatter.

GUIDING THE ROUTER

The router can be guided through the work in any of several ways. The method you use depends, of course, on the demands of the particular job and on convenience.

For routing operations such as grooving or dadoing, it is often necessary to guide the tool in a line parallel to a straight edge. One method of obtaining a straight cut is to securely clamp a board or other straightedge to the work surface, and guide the edge of the router sub-base along this path (Fig. 15).

FIG. 15

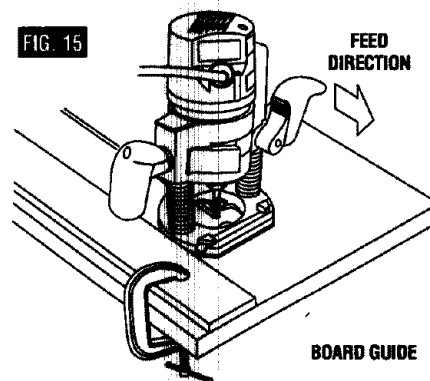

SECURELY CLAMP
BOARD GUIDE

Operating Instructions cont.

CENTERING THE SUB-BASE AND TEMPLATE GUIDE BUSHINGS

Your router's sub-base is precisely centered at the factory. This positions the bit at the center of the sub-base and the template guide bushings (sold separately). This allows you to closely follow jigs, such as straight guides, templates and dovetail fixtures without having the bit "walking off" from the intended cut line for any reason, including the orientation of the router's handles.

In the event that the sub-base or template guide bushings need to be adjusted, follow these steps:

1. Position the sub-base so the screw holes are over the matching set of threaded holes in the base.
2. Insert the screws through the sub-base and tighten them until they are snug, but still allow the sub-base to move.
3. If a template guide bushing (sold separately) is being used, (Fig. 16) attach it as described in Figs 17 and 18.
4. Adjust the sub-base until the sub-base or template guide bushing is centered around the bit as shown in Fig 19.

FIG. 16



FIG. 17

ATTACHING
TEMPLATE
GUIDE
BUSHING
TO FIXED
BASE

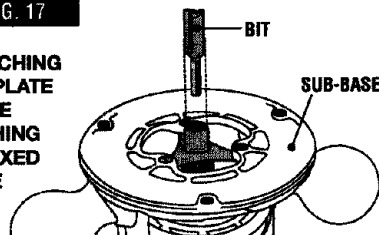
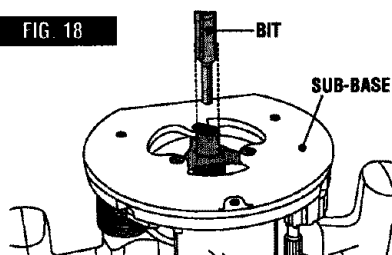

FIG. 18



ATTACHING TEMPLATE GUIDE
BUSHING TO PLUNGE BASE

- A 3 Screw Holes
- B Template Guide Bushing (sold separately)
- C Router Bit (sold separately)

FIG. 19

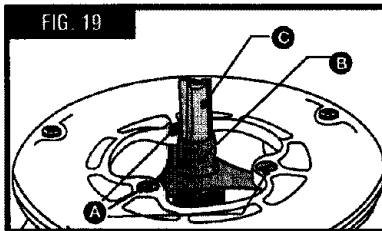

TEMPLATE GUIDE BUSHINGS

Your router's sub-bases are ready to accept the Craftsman Router Template Guide Bushing Set (9-25082), sold separately.

Template guides are used with a number of special accessories, such as dovetail fixtures and hinge templates. In addition, special templates are easily prepared for cutting repeated patterns, special designs, inlays, and other applications. A template pattern can be

made of plywood, hardboard, metal or even plastic, and the design can be cut with a router, jigsaw, or other suitable cutting tool.

Remember that the pattern will have to be made to compensate for the distance between the router bit and the template guide (the "offset"), as the final workpiece will differ in size from the template pattern by that amount, due to the bit position.

Operating Instructions

TO ATTACH TEMPLATE GUIDE BUSHINGS TO ROUTER

1. **DISCONNECT ROUTER FROM POWER SUPPLY WHILE ASSEMBLING PARTS**
2. Attach the guide bushing directly to the inside of the sub-base as shown in Figs. 17, 18, 19. **DO NOT** remove the sub-base from your router to attach the guide bushing.
3. Secure the guide bushing to the sub-base with the 3 screws supplied (#10-32 x 5/8 flat head). Shown in Fig. 16. **BE SURE** the collar section of your guide bushing is turned facing away from the router motor. (See Figs. 17, 18, 19)
4. Open the base clamp lever to release and lower the router motor in router base until the collet nut is approximately 1/8-inch clear of guide bushing.
5. After making adjustment, re-clamp the motor.
6. Insert router bit through guide bushing and into collet at least 1/2-inch, Fig. 19.
7. Tighten collet nut securely.
8. Visually center the cutter with the inside diameter of the guide bushing. **NOTE:** Adjustments can be made by loosening the screws holding the sub-base to the router.
9. Tighten all screws securely. **WARNING: FAILURE TO CENTER CUTTER WITH BUSHINGS OR FAILURE TO FIRMLY TIGHTEN SCREWS AFTER CENTERING COULD CAUSE THE CUTTER TO COME IN CONTACT WITH THE GUIDE BUSHING, RESULTING IN POSSIBLE SERIOUS INJURY.**

WARNING: ALWAYS WEAR SAFETY GLASSES OR EYE SHIELDS WHEN OPERATING YOUR POWER TOOL.

OPERATION

1. Place your router, with guide bushing attached, against template. The template will serve as a guide and restrict the movement of your router within the desired area being cut.
2. Grasp your router and hold it firmly with both hands.
3. Turn router on and let the motor build to its full speed.
4. Gradually feed the cutter into workpiece. **WARNING: KEEP A FIRM GRIP ON ROUTER WITH BOTH HANDS AT ALL TIMES. FAILURE TO DO SO COULD RESULT IN LOSS OF CONTROL LEADING TO POSSIBLE SERIOUS INJURY.**
5. Upon completion of cut, turn motor off and let it come to a complete stop before removing router from work surface.

The following recommended templates are available at your nearest Sears Full-Line Retail Store or at www.craftsman.com on the internet.

Butt Hinge Templates
Dovetail Template
Box Joint Template
Letter and Sign Making Template Set
Replacement Letter Template Set
See the table below for proper selection of bushings, cutters and templates

BUSHING, CUTTER AND TEMPLATE TABLE

BUSHING PILOT O.D.	CUTTER DIA	TYPE.	TEMPLATE
5/16-in.	1/4 INCH	DOVETAIL BIT	DOVETAIL
5/8-in.	1/2 INCH	STRAIGHT BIT	BUTT HINGE
7/16-in.	1/2 INCH	DOVETAIL BIT	DOVETAIL
5/16-in.	1/4 INCH	STRAIGHT BIT	BOX JOINT
5/8-in.	1/2 INCH	STRAIGHT BIT	BOX JOINT

Operating Instructions cont.

USE IN ROUTER TABLE

Your router can also be used in a router table. The fixed base is designed to allow easy depth adjustment in a table. The plunge base is not recommended for use in a router table because it may cause damage to the plunge router base.

To install the fixed base in a table (see Fig. 20), simply remove the sub-base and attach the base using three #10-32 flat head machine screws (not included). The length will depend on the thickness of your router table or router table mounting plate. Follow the drilling and installation instructions that were included with the router table. In order to use the over table adjustment feature on your router, you will also need to drill a hole in the router table or mounting plate to allow access to the fine depth adjustment rod.

The depth can be adjusted over a 7/8-in. range from above the table using the over-table adjustment wrench (included).

When installing a router bit be sure that the coarse adjustment level is near the lowest point of the depth indicator ring.

Also be sure the router bit is installed at the proper height for the cut to be made, (the height of the first cut, if multiple passes are going to be made).

ALWAYS re-clamp the motor in the base **BEFORE** turning on the motor and routing.

For complete instructions on the operation of a router in a router table, refer to the instructions that come with the router table.

FEEDING THE WORKPIECE ON A ROUTER TABLE

Always use your router table's fence or starter pin and the appropriate guard and follow the router table's instruction manual. **ALWAYS** feed the workpiece from right to left across the front of the bit.

Whenever possible, when using the fence, use a push stick to push the workpiece, especially when working with narrow pieces.

FIG. 20

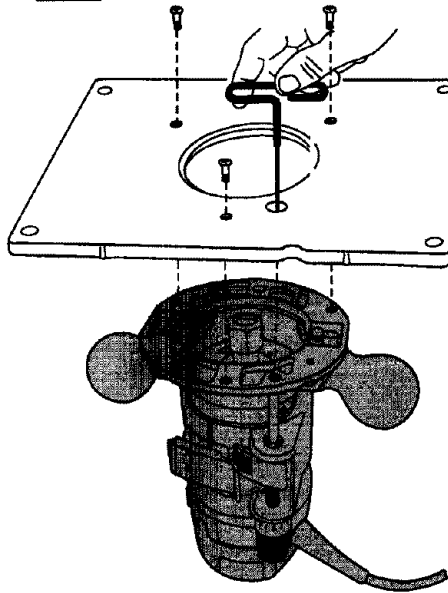
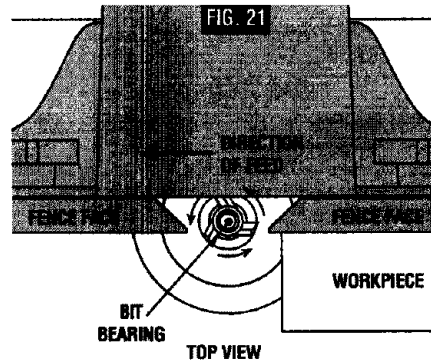

FIG. 21



NOTE: For clarity, guard and featherboard removed from drawing.

Maintenance

SERVICE

⚠ WARNING Preventative maintenance performed by unauthorized personnel may result in misplacing of internal wires and components, which could cause a serious hazard.

1. Tool service **MUST BE** performed only by Sears Service Center. Service or maintenance performed by unqualified personnel could result in a risk of injury.

IMPORTANT NOTE: All service that requires opening the tool should only be performed at a Sears Service Center.

2. When servicing a tool, **ALWAYS** use only identical replacement parts. Follow instructions in the Maintenance Section of this manual. Use of unauthorized parts or failure to follow Maintenance instructions may create a risk of electric shock or injury.

TOOL LUBRICATION

Your CRAFTSMAN Professional Router has been properly lubricated and is ready to use. It is recommended that tools with gears be regreased with a special gear lubricant whenever brushes are changed.

CARBON BRUSHES

The brushes and commutator in your CRAFTSMAN Professional Router have been engineered to provide many hours of dependable service. To maintain the peak efficiency of the motor, we

recommend that you take the tool to a Sears Service Center and have the brushes examined every two to six months depending on the amount of tool usage. Only use replacement brushes that are specially designed for use with your CRAFTSMAN Professional Router.

BEARINGS

After about 300 to 400 hours of operation, or at every second brush change, the bearings should be replaced by Sears Service Center. Bearings which become noisy (due to heavy load or very abrasive material cutting) should be replaced immediately to avoid overheating or motor failure.

CLEANING

⚠ WARNING To avoid accidents, **ALWAYS** disconnect the tool from the power source **BEFORE** cleaning or performing any maintenance. The tool may be cleaned very effectively with compressed air. **ALWAYS** wear safety goggles when cleaning tools with compressed air. Ventilation openings and switch levers must be kept clean and free of foreign matter. **DO NOT** attempt to clean by inserting pointed objects through the openings.

⚠ WARNING Certain cleaning agents and solvents cause damage to the plastic parts. These include gasoline, carbon tetrachloride, chlorinated cleaning solvents, ammonia and household detergents that contain ammonia.

Accessories

The following recommended accessories are currently available at your local Sears Store.

EXTENSION CORDS

⚠ WARNING If an extension cord is necessary, a cord with adequate size conductors that is capable of carrying the current necessary for your tool must be used. This will prevent excessive voltage drop, loss of power or overheating. Grounded tools must use 3-wire extension cords that have 3-prong plugs and receptacles.

NOTE: The smaller the gauge number, the greater capacity of the cord. 16 gauge wire has more capacity than 18 gauge wire.

RECOMMENDED SIZES OF EXTENSION CORDS FOR 120-VOLT (ALTERNATING CURRENT) POWER TOOLS

Tool's Ampere Rating	Cord Sizes in A.W.G.				Wire Sizes in mm ²			
	Cord Length in Feet				Cord Length in Meters			
	25	50	100	150	15	30	60	120
3-6	18	16	14	12	.75	.75	1.5	2.5
6-8	18	16	14	12	.75	1.0	2.5	4.0
8-10	18	16	14	12	.75	1.0	2.5	4.0
10-12	16	16	14	12	1.0	2.5	4.0	-
12-16	14	12	-	-	-	-	-	-

SEARS OFFERS A LARGE SELECTION OF ACCESSORIES FOR YOUR ROUTER

- Individual router bits and a variety of router bit sets
- Template Guide Bushings
- Hinge Mortising Template Kit
- 12-in Dovetail Template Kit
- 16-inch Dovetail Box
- Router Tables
- Joint System

⚠ WARNING The use of attachments or accessories that are not recommended might be dangerous.

Replacement Parts

ROUTER KIT – MODEL NUMBER 130.26620

The Model Number will be found on the Nameplate.

Always mention the Model Number in all correspondence regarding your tool.

SEE BACK PAGE FOR PARTS ORDERING INSTRUCTIONS.

PARTS LIST

Pos.	Part Number	Description	Qty
Motor			
1	2610922584	Motor Housing	1
2	3604220569	Field	1
3	3604011620	Armature	1
4	2610913918	Switch	1
7	2601035001	Cord Clamp	1
13	3600905513	Ball Bearing	1
14	3600905512	Ball Bearing	1
21	2610991373	Baffle	1
22	1604477005	Terminal	2
29	2610993582	Nut	1
30	2610906283	Collet Assembly 1/4"	1
30	2610906284	Collet Assembly 1/2"	1
31	2610923210	Rear Housing	1
32	2610991375	Bearing Sleeve	1
33	1900210115	O-Ring	1
34	2610923212	Cover	1
35	2610923175	Speed Control	1
61	2910611006	Screw	4
62	2610991306	Screw	2
74	2910641120	Screw	2
75	2610910566	Screw	4
77	2910141166	Screw	2
653	2610992417	Wrench 24mm	1
654	2610991388	Wrench 16mm	1
803	3601352502	Terminal	1
804	3601352501	Terminal	1
805	3604460560	Cord	1
806	3600703512	Strain Relief	1
810	3604321514	Brush Set	1
816	3604336506	Brush & Holder Set	1
817	3604652501	Brush Spring Set	1

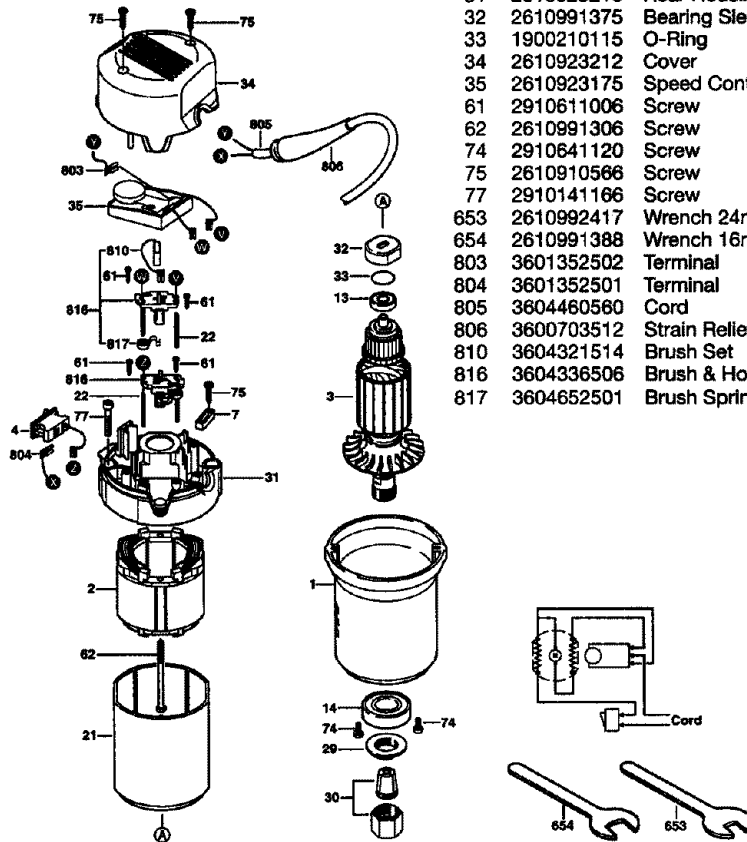

Replacement Parts

ROUTER KIT – MODEL NUMBER 130.26620

The Model Number will be found on the Nameplate.

Always mention the Model Number in all correspondence regarding your tool.

SEE BACK PAGE FOR PARTS ORDERING INSTRUCTIONS.

PARTS LIST

Fixed Base

Pos.	Part Number	Description	Qty
39	2610919706	Handle	2
40	2610922557	Base	1
41	1613300006	Nut	1
42	2610915060	Clamp Lever Assembly	1
44	2610922527	Adjusting Rod	1
45	2610991385	Pivot Lever	1
46	2610991371	Spring	1
48	2610993576	Knob	1
49	2610993577	Indicator Ring	1
50	2610922560	Sub Base	1
55	2610991389	Chip Shield	1
56	2610991372	Cap	1
63	2910011219	Screw	2
66	2918660004	Washer	1
70	2610996054	Retaining Ring	1
71	2610994492	Pin	1
73	2610917210	Screw	3
75	2916079032	Lock Washer	2
76	2916011013	Washer	2
655	2610923193	T-Handle Hex Wrench 1/8" 1	

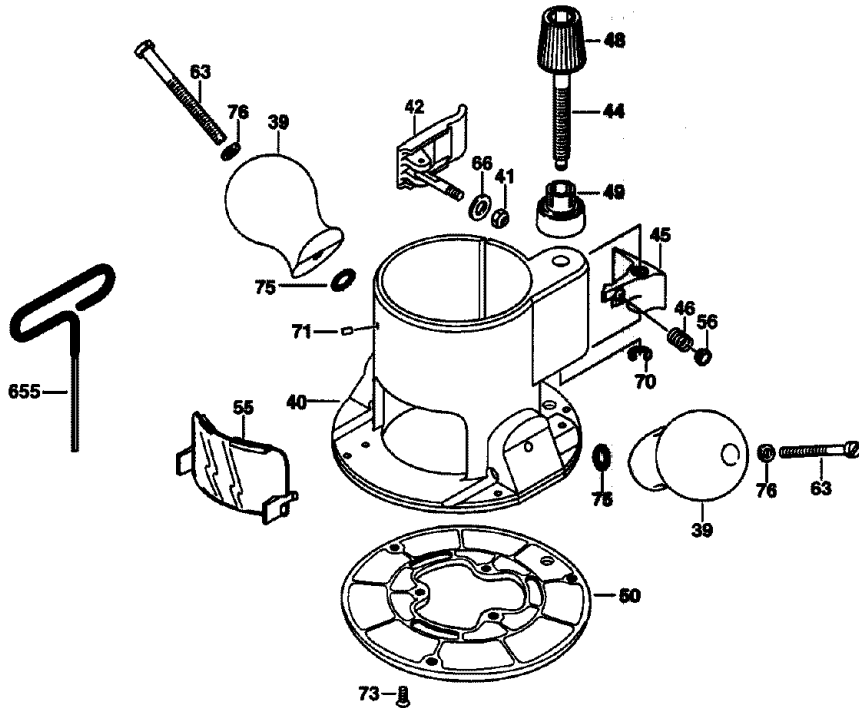

Replacement Parts

ROUTER KIT – MODEL NUMBER 130.26620

The Model Number will be found on the Nameplate.

Always mention the Model Number in all correspondence regarding your tool.

SEE BACK PAGE FOR PARTS ORDERING INSTRUCTIONS.

Pos.	Part Number	Description	Qty
127	2610922561	Sub Base	1
130	2916650003	Retaining Ring	1
131	1900210111	O-Ring	1
144	3603450504	Lock Bolt	1
145	3604651503	Spring	1
146	3602000510	Lever	1
147	2910641122	Screw	1
148	2916680005	Lock Washer	1
155	2610912599	Chip Deflector	1
156	2610922093	Depth Label	1
157	2610997094	Pointer	1
158	2610912600	Rod	1
159	2610917057	Wing Screw	1
160	2610912601	Adjustment Knob	1
161	2610068154	O-Ring	1
170	3600232503	Depth Stop	1
171	2600590006	Cap/Spring	1
172	3603415556	Screw	1
173	3916060500	Washer	1
183	2918660004	Washer	1
184	1613300006	Nut	1
186	2610915060	Clamp Lever Assembly	1
801	2610923153	Motor Carrier Assembly	1
826	2610997115	Base Assembly	1
110	2610912594	Dust Cover	1
111	2610990022	Screw	1
112	2610914852	Clip Plug	1
116	2916079032	Lock Washer	2
117	2610994492	Pin	1
118	2610996143	Screw	2
119	2610913441	Screw	4
120	2610919932	Right Handle	1
121	2610920770	Left Handle	1
122	2610914839	Support Disc	2
123	2610912598	Compression Spring	2
124	3605510548	Bellow	2
125	2610917210	Screw	3

PARTS LIST

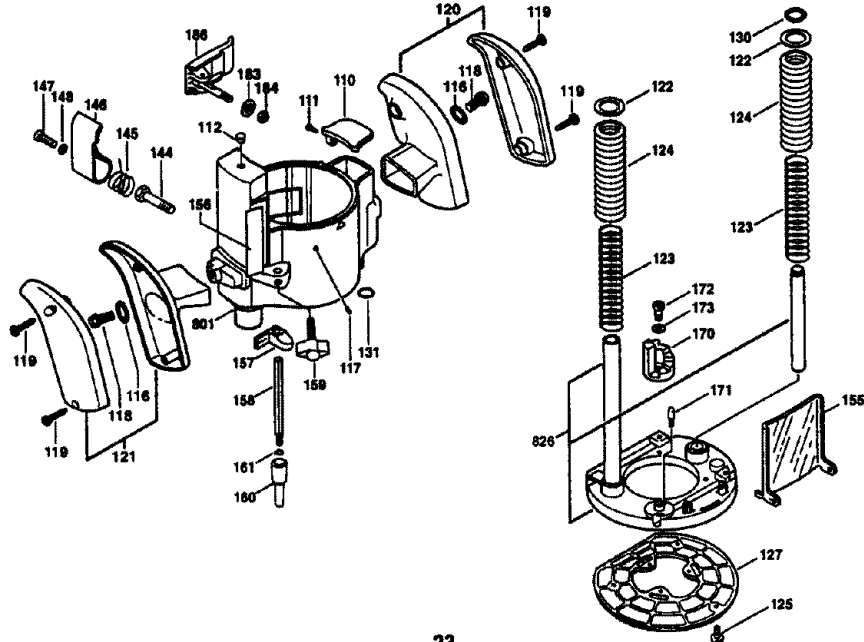

Get it fixed, at your home or ours!

Your Home

For repair **in your home** of **all** major brand appliances, lawn and garden equipment, or heating and cooling systems, **no matter who made it, no matter who sold it!**

For the replacement parts, accessories and owner's manuals that you need to do-it-yourself.

For Sears professional installation of home appliances and items like garage door openers and water heaters.

1-800-4-MY-HOME[®] Anytime, day or night
(1-800-469-4663) (U.S.A. and Canada)
www.sears.com **www.sears.ca**

Our Home

For repair of carry-in products like vacuums, lawn equipment, and electronics, call or go on-line for the nearest **Sears Parts and Repair Center.**

1-800-488-1222 Anytime, day or night (U.S.A. only)
www.sears.com

To purchase a protection agreement (U.S.A.) or maintenance agreement (Canada) on a product serviced by Sears:

1-800-827-6655 (U.S.A.) **1-800-361-6665** (Canada)

Para pedir servicio de reparación a domicilio, y para ordenar piezas:

1-888-SU-HOGARSM
(1-888-784-6427)

Au Canada pour service en français:

1-800-LE-FOYER^{MC}
(1-800-533-6937)
www.sears.ca

SEARS

© Sears, Roebuck and Co.

[®] Registered Trademark / [™] Trademark / SM Service Mark of Sears, Roebuck and Co.

[®] Marca Registrada / [™] Marca de F. blica / SM Marca de Servicio de Sears, Roebuck and Co.

^{MC} Marque de commerce / ^{MD} Marque déposée de Sears, Roebuck and Co.