

文件编号	
修改版次	02
图纸编制: 潘传康	
日期: 20250809	

公差要求
彩盒: +1/-0mm
纸卡、说明书: ±1mm
标签、标贴: ±0.2mm
吸塑: ±0.5mm
袋类: +3/-1mm
珍珠棉、缓冲材料、内盒: +2/-1mm
外箱: +5/-1mm

工艺要求
展开尺寸: W400 x H110mm
折叠尺寸: W80 x H110mm
折叠方式: 风琴5折, 折后英文版封面朝外
材质: 80g书写纸, 印后过耐磨油
印刷要求: CMYK 4C印刷, 印后不能出现错印, 漏印, 重影, 模糊现象。

名称: 手机免笼双语使用说明书	型号: BFT-03A	单位: mm
客户编号: 霸方 (B0001)	图纸编号: BFT03A-B0001-ML-01	日期: 20250809

110mm

400mm

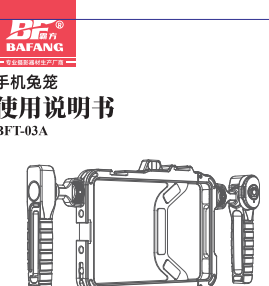

手机免笼 使用说明书
BFT-03A

①使用前请仔细阅读本说明书, 请保留说明书以备后续参考使用>>>

注意事项

- 移动免笼, 云台, 三脚架或其它辅助拍摄设备时, 请务必手持手机, 以确保稳固安全;
- 本产品不防水, 避免入水中使用, 如雨水淋湿, 擦干后不影响使用;
- 本产品可在-40°C至60°C温度范围外环境使用;
- 此说明书所有图示仅为解释目的, 其外观与实物不一致时, 请以实物为准。

包装清单

手机免笼 *1、六角扳手*1、产品合格证*1、说明书*1

产品参数

型号: BFT-03A
产品尺寸: 约W243 x D30 x H114mm
产品材质: 航空铝合金镁质氧化
适用机型: 宽度在58-90mm之间的手机

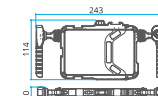

安装步骤

1. 免笼连接与调节:
A. 手柄安装: 将手柄连接杆上的螺丝与免笼侧螺丝孔对齐并用六角扳手旋转拧紧螺丝, 安装完成 (图1)。以相同的安装方式安装另一个手柄 (反之拆卸手柄)。

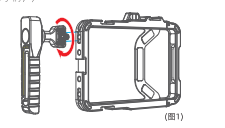

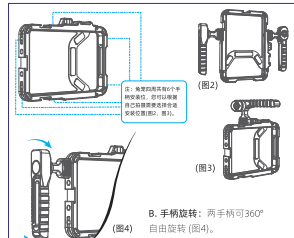

2. 手机安装: 将手机向外拉, 调节免笼内部尺寸, 手机装入免笼并与其持平, 然后松开手柄夹夹手机完成安装 (图5)。

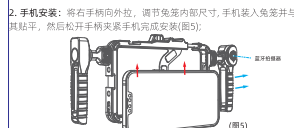

蓝牙拍摄器连接与照

- 准备: 首先在手机设置里打开蓝牙;
- 开关机: 长按拍照键3秒进行开关机;
- 蓝牙配对: 开机后指示灯蓝光灯闪烁后进入配对状态, 等待配对过程中指示灯蓝光灯熄灭, 此时在手机蓝牙页面搜索并找到“DPT-01”进行匹配连接, 连接成功后面指示灯熄灭;
- 蓝牙电池 (纽扣电池, 型号CR1225)
- 拍照: 拍摄器与手机处于连接状态时, 轻按拍照键进行拍照, 指示灯蓝光灯闪烁1次;
- 注: 1. 开机或休眠唤醒后, 如已配对手机的蓝牙是打开状态, 拍摄器会自动与手机连接;
- 2. 开机后, 无配对连接状态下, 5分钟内无操作蓝牙拍摄器自动关机, 配对连接状态下, 10分钟内无操作蓝牙拍摄器进入休眠状态。

拓展功能介绍

免笼包含1/4螺纹孔, 冷却接口等多个外拓展口。

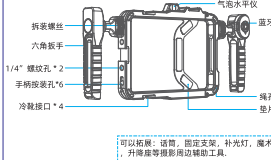

拆架螺丝
六角扳手
1/4" 螺纹孔 * 2
手柄按钮 * 6
冷却接口 * 4

气态水平仪
蓝牙拍照键
镜头
垫片

可以拓展: 磁吸、固定架、补光灯、魔爪手柄、升降器等摄影用辅助工具。

保修及售后服务

本产品享有售后保修服务, 在购买产品15日内, 如有任何质量问题经检测确属免费更换。购买本产品一年内出现质量问题, 可免费维修。

注: 产品退换货及保修不适用于下列情况:

1. 误用、意外、改装、不适当的物理或操作环境、自然灾害、不当维护或保管导致的故障或损坏;
2. 第三方产品、服务或行为导致的故障或损坏;
3. 产品在使用过程中发生的磨损、磨擦和消耗。

用户信息	用户名	电子邮箱
	通信地址	
	联系电话	邮政编码
产品信息	产品名称	产品条码/编号/批号
	名称	
经销商信息	地址	邮政编码
	联系电话	销售日期
	销售日期	发票号码
备注		

正面



Phone Cage User Manual
BFT-03A

①Please read this manual carefully before use and keep it for future reference>>>

Warnings

1. When using the cage, ball head, tripod or other auxiliary photography equipment, please be sure to hold the phone with your hand to ensure safe use;
2. This product is not waterproof, avoid immersing it in water. If it is wet by rain, it will not affect its use after drying;
3. This product can only be used in an environment with a temperature range of 40°C to 60°C;
4. All illustrations in this manual are for explanation purposes only. If the appearance is inconsistent with the actual product, please refer to the actual product.

Package List

Phone Cage *1, Hexagonal Wrench *1, Certificate *1, User Manual *1

Specifications

Model: BFT-03A
Product Dimensions: About W243 x D30 x H114mm
Materials: Aviation Aluminum Alloy
Compatible for: Cell Phone with a width of 58mm-90mm

Install Steps

1. Assembly and Adjustment of the Phone Cage:
A. Handle Installation: Align the screw on the handle connector with the screw hole on the side of the phone cage, and tighten the screw using a hex key (Figure 1). This completes the installation of one handle, install the other handle in the same manner (reverse these steps to remove the handles);

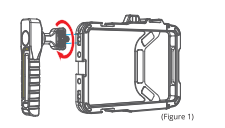

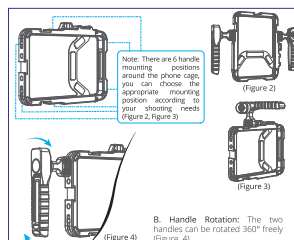

2. Phone Installation
Pull the right handle outward to adjust the internal dimensions of the phone cage, insert the phone into the cage and align it properly, then release the handle to secure the phone in place (Figure 5).

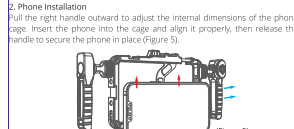

Wireless Remote Control

- Preparation: First, turn on Bluetooth in your phone's settings;
- Power On and Off: Long Press the wireless control button for 3 seconds to turn it on and off;
- Bluetooth Pairing: After turning on the device, the indicator light turns blue and flashes quickly for 5 seconds to enter the pairing state. During the pairing process, the indicator light flashes blue slowly. At this time, search and find "DPT-01" on the Bluetooth page of the mobile phone to match and connect. After the connection is successful, the indicator light goes out;
- Bluetooth battery Button cell, model CR1225)
- Photographing: When the camera is connected to the mobile phone, press the camera button to take a photo. The indicator light turns blue and flashes once;

Note: 1. After powering on or waking up from sleep mode, if the Bluetooth of the paired phone is turned on, the camera will automatically connect to the paired phone;
- 2. After powering on, if there is no paired connection and no operation within 5 minutes, the Bluetooth camera will automatically shut down; if there is no operation within 10 minutes in the paired connection state, the Bluetooth camera will enter sleep mode.

Extended Function Introduction

The cage contains multiple 1/4" and 3/8" threaded holes, cold shoe interface and other external interfaces.

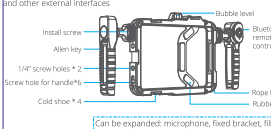

Install screw
Allen key
1/4" screw holes * 2
Screw hole for handles
Cold shoe * 4

Bubble level
Bluetooth remote control
Rope hole * 4
Rubber pad

Can be expanded: microphone, fixed bracket, fill light, magic hand, lifting head and other accessories.

Service Warranty

The products enjoys after-sales warranty service. If there is any quality problem within 15 days after purchasing, you can contact the dealer for replacement. If the product has quality problems within one year after purchase, it can be repaired for free.

*Note: Product return and maintenance are not applicable to the following situations:

1. Due to misuse, accident, modification, improper physical or operating environment, natural disasters, improper maintenance or storage, Failure of damage caused;
2. Failure or damage caused by products, services or behaviors of the third party;
3. Discoloration, wear and consumption during the use of the product.

Customer Information	Name	Email
	Address	
	Phone number	Code
Product Information	Name	Barcode/Model number/Batch number
	Model	
	Name	
Distributor Information	Address	Code
	Phone number	Invoice number
	Selling date	
Remarks		

反面

展开尺寸: W400 x H110mm
 折叠尺寸: W80 x H110mm
 折叠方式: 风琴5折, 折后英文版封面朝外
 材质: 80g书写纸, 印后过耐磨油
 印刷要求: CMYK印刷, 印后不能出现错印, 漏印, 重影, 模糊现象。

FCC Warning:

This equipment has been tested and found to comply with the limits for a Class B digital device, pursuant to part 15 of the FCC Rules. These limits are designed to provide reasonable protection against harmful interference in a residential installation. This equipment generates, uses and can radiate radio frequency energy and, if not installed and used in accordance with the instructions, may cause harmful interference to radio communications. However, there is no guarantee that interference will not occur in a particular installation. If this equipment does cause harmful interference to radio or television reception, which can be determined by turning the equipment off and on, the user is encouraged to try to correct the interference by one or more of the following measures:

- Reorient or relocate the receiving antenna.
- Increase the separation between the equipment and receiver.
- Connect the equipment into an outlet on a circuit different from that to which the receiver is connected.
- Consult the dealer or an experienced radio/TV technician for help.

Caution: Any changes or modifications to this device not explicitly approved by manufacturer could void your authority to operate this equipment.

This device complies with part 15 of the FCC Rules. Operation is subject to the following two conditions:

(1) This device may not cause harmful interference, and (2) this device must accept any interference received, including interference that may cause undesired operation.

This equipment complies with FCC radiation exposure limits set forth for an uncontrolled environment. This equipment should be installed and operated with minimum distance 0cm between the radiator and your body.