

Ruko[®]

14+
for age

User Manual

v1.0

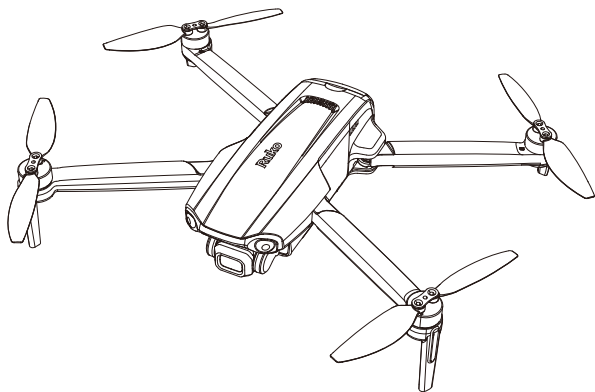

F11PRO 2

CONTACT US FOR MORE TECH SUPPORT

 +1 (888)892-0155 | Mon-Fri 7:00AM - 7:00PM (PST)



rukotoy.com

CONTACT US FOR MORE TECH SUPPORT

 +1 (888)892-0155 | Mon-Fri 7:00AM - 7:00PM (PST)

 +1 (732) 207-0697



Content

1. Reading Tips	1
1.1 Symbols Explanation	1
1.2 Read Before the First Flight	1
1.3 Download App	1
1.4 Tutorial Videos	2
1.5 FAA Remote ID Registration Process	2
2. Product Profile	8
2.1 Introduction	8
2.2 Product List	8
2.3 Diagram	9
3. Aircraft	13
3.1 Speed Mode	13
3.2 Aircraft Status Indicator	14
3.3 Optical Flow Positioning	15
3.4 Propellers	16
3.5 Smart Flight Battery	17
3.6 Camera Overview	21
4. Remote Controller	24
4.1 Introduction	24
4.2 Remote Controller Instructions	24
4.3 Communication Range	28
4.4 Remote Controller Pairing	29

5. Ruko Mini App	30
5.1 Home Screen	30
5.2 Control Interface	31
5.3 Parameter	34
5.4 Track	36
5.5 Other	37
6 Flight	38
6.1 Flight Environment Requirements	38
6.2 Pre-Flight Checklist	39
6.3 Pairing Remote Controller with Aircraft	39
6.4 Connect the Data Cable	40
6.5 Compass Calibration	42
6.6 Gyroscope Calibration	44
6.7 Starting/Stopping the Motor	45
6.8 One-key Takeoff/Landing	46
6.9 Return to Home (RTH)	48
6.10 Smart Flight (Route Planning, GPS Follow, Fly Around, Cruise Control)	52
6.11 How to take off the Aircraft	59
6.12 Aerial Photography Tips	60
7. Appendix	60
7.1 Specifications & Parameters	60
7.2 Accessories Support	63
7.3 Common Problems and Solutions	64

1. Reading Tips

1.1 Symbol Explanation

- ✓ Recommend ✗ Warning ⚠ Hints & Tips 📖 Reference

1.2 Read Before the First Flight

- Read the following documents before using the Ruko F11PRO 2
 1. User Manual
 2. Flight Guide & Safety Disclaimer
- It is recommended to watch all tutorial videos on our website and read the Flight Guide & Safety Disclaimer before using for the first time.

1.3 Download the Ruko Mini App

- Please make sure to use Ruko Mini App during the flight. Scan the QR code to download the latest version of the app.
- Ruko Mini App supports Android 7.1 or higher, iOS 13.0 or higher.



(For Android)



(For iOS)

1.4 Tutorial Videos

- Scan the QR code to watch the tutorial videos to ensure correct and safe use of the product.



1.5 FAA Remote ID Registration Process

1.5.1 Find the Serial Number

- The F11PRO 2 comes with a built-in FAA Remote ID module. You can obtain the unique Remote ID serial number through the app or on the aircraft itself. Please register according to your local regulations.

① Remote ID serial number on the aircraft.

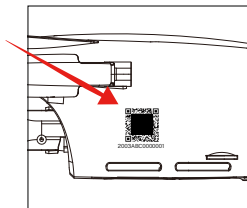

- ② Ruko Mini App: Successfully pair the aircraft with the remote controller --> Insert the data cable --> enter the “Ruko Mini” app --> enter CONTROL page --> Click the power icon in the upper right corner --> the RID information will pop.

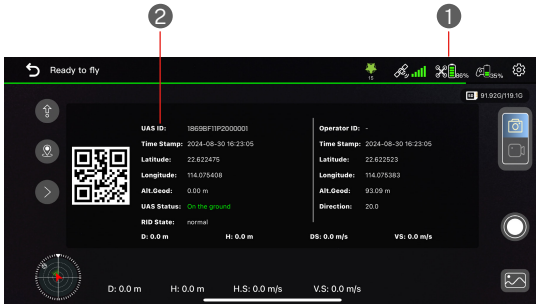

1.5.2 Registration

- ① Please go to FAA website: <https://faadronezone-access.faa.gov/#/>
- ② Please complete and submit the information following these steps.

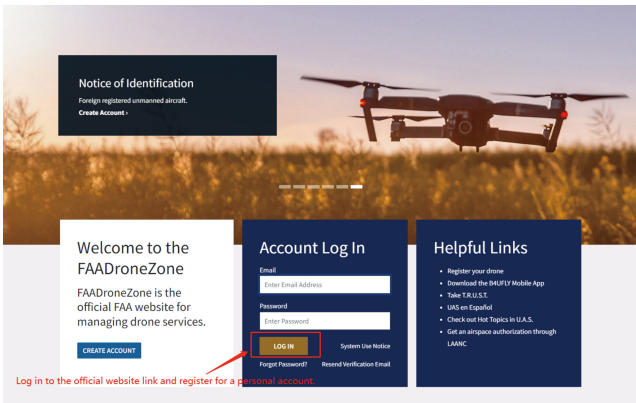

An official website of the United States government [here's how you know](#) ▼
United States Department of Transportation

Federal Aviation Administration
FAADroneZone

Contact Drone Events Hi, jing + Log Out

Recreational Flyers Certificated Remote Pilots Public Safety & Government Educational Institutions Where Can I Fly? UAS en Español

HOME / FAADroneZONE SERVICES

Select Add "Drone Owners and Pilots" item

FAADroneZone Services

Thank you for registering an FAADroneZone Access account. To proceed, simply add an FAADroneZone Service using the Add a Service option below.

Drone Owners and Pilots

Drone Owners and Pilots who need to complete the following tasks:

- Registration
- Waivers
- Airspace Authorizations

Not sure which rules to follow? We can help you >

[LAUNCH DRONE OWNERS AND PILOTS DASHBOARD](#)

+ Add a Service

An official website of the United States government [here's how you know](#) ▼
United States Department of Transportation

Federal Aviation Administration
FAADroneZone

Contact Hi, jing + Log Out

Part 107 Add Account Type

PART 107 DASHBOARD

Part 107 Dashboard

Inventory

1
Total Devices

1 Active Device

[MANAGE DEVICE INVENTORY](#)

Part 107 Users

1
Total Users

1 Active User

[MANAGE USER ACCOUNTS](#)



Your Shopping Cart

Part 107 operators must add manufacturer and model information for all UAS that they own and operate. For standard remote identification UAS and broadcast modules, you'll also be required to provide the serial number. Each broadcast module serial number may only be associated with a single, specific UAS and may not be listed on more than one registration.



ADD DEVICE

Add Device

* Indicates a required field or that a selection is required.

DOES YOUR DRONE BROADCAST FAA REMOTE ID INFORMATION?*

 YES NO

Not sure? Contact your UAS manufacturer or see if your drone is listed here: <https://uasdoc.faa.gov/listDocs>

UAS TYPE* Standard Remote ID

NICKNAME Enter a Nickname

UAS MANUFACTURER* Ruko

UAS MODEL* F11PRO 2

REMOTE ID SERIAL NUMBER* 1869BF11P2000001

Not sure if you have a Remote ID Serial Number? Contact your Manufacturer.

CANCEL

ADD DEVICE



Your Shopping Cart

ADD DEVICE

Part 107 operators must add manufacturer and model information for all UAS that they own and operate. For standard remote identification UAS and broadcast modules, you'll also be required to provide the serial number. Each broadcast module serial number may only be associated with a single, specific UAS and may not be listed on more than one registration.

Filter by

NICKNAME	UAS MANUFACTURER	UAS MODEL	SERIAL NUMBER	REMOTE ID	DEVICE TYPE	ADDED BY	AMOUNT	ACTIONS
Ruko	F11PRO 2	1B69BF1P2000001	Yes	Standard Remote ID	jing Lian	\$5.00		
						TOTAL:	\$5.00	

Select "CHECKOUT" and fill in your personal information to make a payment of \$5

CHECKOUT



1. Operational Requirements 2. Payment 3. Review & Pay 4. Confirmation

Payment Information

* Indicates a required field.

Credit Card Info

Complete the above steps

CARD NUMBER* CVC/CVV* EXPIRATION* /

MARK YOUR AIRCRAFT!

- When you register, you will receive a unique registration number valid for 3 years. After 3 years, you must renew your aircraft registration.
- You must mark each aircraft with the assigned unique registration number before it is operated.

Billing Address

Use Mailing Address

FIRST NAME* LAST NAME*

COUNTRY*

ADDRESS* ADDRESS

CITY* STATE / PROVINCE / REGION*

ZIP*

BACK

NEXT

Small UAS Certificate of Registration	
Registered Owner: JingYuLian	<p><i>This Small UAS Certificate of Registration is not an authorization to conduct flight operations with an unmanned aircraft. Operations must be conducted in accordance with applicable FAA requirements. The operator of the aircraft is responsible for knowing and understanding what those requirements are. For more information on flying requirements, please visit the FAA website at www.faa.gov/uas</i></p> <p><i>For U.S. citizens, permanent residents, and certain non-citizen U.S. corporations, this document constitutes a Certificate of Registration. For all others, this document represents a recognition of ownership.</i></p> <p><i>Operators of unmanned aircraft must ensure they comply with the appropriate safety authority from the FAA and economic authority from the DOT.</i></p>
UAS Manufacturer: Ruko	
UAS Model: F11PRO 2	
Serial Number: 1869BF11P2000001	
Registration Number: FA3KTPA3H3	
Issued: 07/06/2023 Expires: 07/06/2026	



- The aircraft will start broadcasting the FAA remote ID signal when the aircraft's motors begin to spin.

2 Product Profile

2.1 Introduction

- The Ruko F11PRO 2 features a foldable design and weighs about 357g. It offers stable hovering and flying capabilities outdoors with impressive shooting performance. Equipped with upgraded 5.8GHz Wi-Fi FPV real-time transmission, it includes a 75° FOV lens and a 90° adjustable camera. The camera captures 4K HD video and 6K UHD photos, providing a wide view to capture your moments. The advanced flight-control system ensures agile, stable, and safe flying. With auto RTH, the aircraft will automatically return to its starting point and land if it loses signal or the battery is low. Please use the product in accordance with local laws and regulations.

2.2 Product List

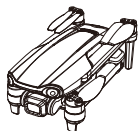

Drone



Remote Controller



Smart Flight Battery



Camera Cover



Spare Propeller

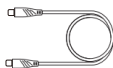

Charging Cable



Screwdriver



Screw



Type-C to Micro-USB cable



Type-C to Type-C cable



Type-C to Lightning cable



User Manual

Flight Guide &
Safety Disclaimer

Type-C to Type-C cable is stored inside the remote controller when shipped.

2.3 Diagram

2.3.1 Aircraft Diagram

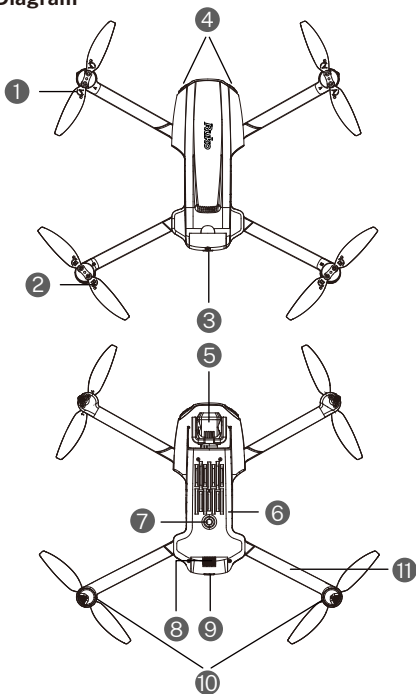

- | | |
|----------------------------------|-----------------------------------|
| ① Propeller | ⑥ SD Card Slot |
| ② Motor | ⑦ Optical Flow Sensor |
| ③ Smart Flight Battery | ⑧ Battery Buckle |
| ④ LED Light | ⑨ Power Button |
| ⑤ 3 Axis Brushless Gimbal Camera | ⑩ Aircraft Status Indicator Light |
| | ⑪ Arm |

2.3.2 Remote Controller Diagram

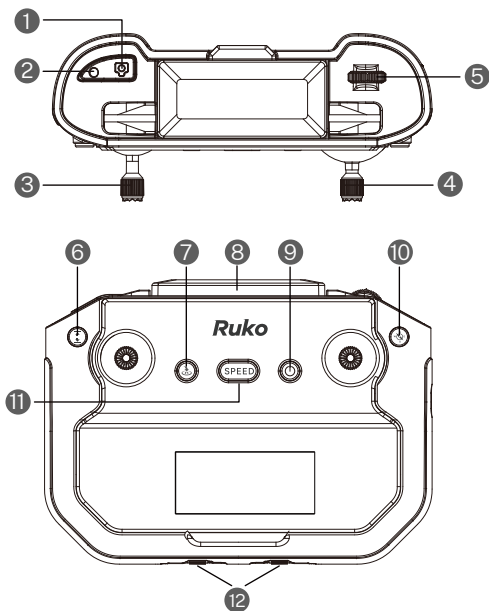

1 Shutter Button

Short press once to take a picture.

2 Record Button

(1) Record: Short press it to start/stop recording.

(2) Switch to Japanese stick mode: Hold down the recording button and then power on the remote controller (Short-press it then long-press the power button).

3 Left Joystick

(American stick mode) Throttle stick, used to adjust the aircraft's altitude and control the direction of the front of the aircraft. For more details, please refer to section 4.2.5.

4 Right Joystick:

Directional stick, used to control the aircraft's flight direction (forward/backward/left/right). For more details, please refer to section 4.2.5.

- 5 Gimbal Gear**
Adjust the Gimbal Camera Angle.
- 6 One-key Takeoff/ Landing and Cruise Control Button**
(1)One-key Takeoff: After unlocking the motor, long press it and the aircraft will automatically take off to a height of about 1.5 meters.
(2)One-key Landing: Long press it while the aircraft is flying and the aircraft will descend to the ground at the existing coordinates.
(3)Cruise Control: Press this button while operating the joysticks to activate the Cruise Control.
- 7 Smart RTH Button**
(1)Press it to initiate automatic Return-to-Home (RTH), where the aircraft will return to its takeoff location and land. (There may be a deviation of up to 3 meters from the takeoff position, depending on GPS signal strength at takeoff.)
(2)To cancel the RTH process, press the button again during the return.
- 8 Mobile Phone Holder**
Flip up to open the holder for placing the mobile phone. The width of the phone holder is adjustable. The maximum adjustable width is suitable for a 6.7-inch phone.
- 9 Power Button**
(1)Turn on the remote controller: Short-press it then long-press it
(2)Turn off the remote controller: Long-press it
(3)Check the power level: Short-press it once
- 10 Compass Calibration Button**
(1)Enter compass calibration: Short press it
(2) GPS mode/ Attitude mode:
① If GPS signal is not found, press and hold the button for 3 seconds to turn off GPS and switch the aircraft to Attitude Mode.
② When the aircraft is in Attitude Mode, press and hold the button for 3 seconds to turn on GPS and switch to GPS Mode.
 (GPS is turn on by default when powering on, please do not turn it off when flying outdoors to avoid losing the aircraft). (Once GPS signal is acquired, you cannot switch back to Attitude Mode.)
- 11 SPEED Button**
Press down for speed adjustment, (2 speeds in total) default is stable mode, accelerate is sport mode.
- 12.Sticks Storage Hole**

2.3.3 Remote Controller Display

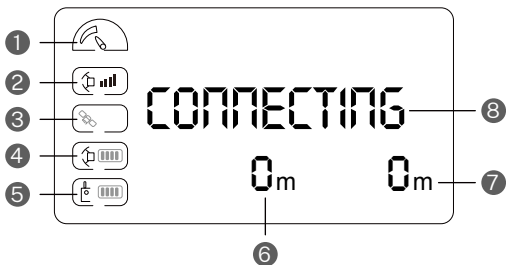

① Speed

② Aircraft Connection Signal

③ GPS Signal

④ Aircraft Power

⑤ Remote Controller Power

⑥ Flight Distance

⑦ Flight Height

⑧ Status Display

3. Aircraft

- F11PRO 2 aircraft consists of a flight control system, a communication system, an image system, a power system and a smart flight battery.

3.1 Speed Mode











- F11PRO 2 has two speed modes, Stable Mode and Sport Mode. After the aircraft is turned on, the stable speed mode is turned on by default. You can switch by pressing the SPEED button on the remote controller. The stable mode speed is 6m/s and the sport mode speed is 8m/s.



- When wind speed is high, sport mode should be maintained to improve wind resistance effect.
- When flying in sport mode, the pilot should reserve at least 3 meters of braking distance to ensure flight safety.
- When flying in sport mode, the power of the aircraft will be greatly improved, and the small manipulations of the joysticks on the remote controller can result in large flight maneuvers of the aircraft. Please reserve enough flying space to ensure the safety of the flight.

3.2 Aircraft Status Indicator

- The F11PRO 2 status indicator light is located above the front landing gear and is used to display the current status of the flight. Please refer to the table below to understand what each flashing pattern indicates.

Blinking status of the indicator		Conditions
	Indicator is in solid yellow	Optical flow positioning
	Indicator is in solid green	GPS mode (GPS signal search completed)
	Indicator off for 1 second	Taking pictures
	Indicator flashes twice at intervals in yellow	Recording Video
	Indicator flashes slowly in yellow	Frequency Calibration in Progress
	Indicator flashes slowly in red	Low battery
		The aircraft was not placed on a level surface after pairing
	Indicator flashes quickly in yellow	Enter compass calibration
	Indicator flashes quickly in green	Weak GPS signal
	Indicator is in solid red	During Return to Home
		Searching for GPS signal
	Indicator flashes quickly for 2 seconds in yellow	Enter gyroscopes calibration

3.3 Optical Flow Positioning

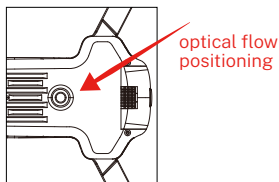
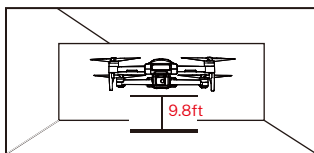

- The aircraft is equipped with a downward vision positioning system, which enhances its ability to adapt to different environments. This system, composed of downward vision cameras and sensors, allows the aircraft to hover steadily at low altitudes or indoors, even when GPS is unavailable or the signal is weak.



- Optical flow positioning can only assist flight in environments with sufficient lighting and textured surfaces. It cannot fully replace user judgment, so please pay attention to the aircraft's status and the APP prompts. Do not overly rely on the optical flow positioning.
- Optical flow positioning may perform poorly or fail in environments that are too bright, too dark, mirror-like, smooth single-colored surfaces, water surfaces, reflective surfaces, or sparsely textured surfaces.
- The optimal working range for optical flow positioning is between 1.64ft (0.5m) to 9.84ft (3m). Beyond this range, the performance of the downward optical flow vision system may be less effective, so please fly with caution.
- Ensure that the lens of the optical flow vision system is clean, and avoid blocking or interfering with it.
- Optical flow positioning can only be used in attitude mode. When the aircraft successfully acquires a GPS signal outdoors, it will automatically switch to GPS positioning mode.

3.4 Propellers

- The propellers on the adjacent motors of the F11PRO 2 are forward and reverse propellers. The two propellers on the same motor are the same, and the propellers are marked A and B respectively.

Propellers	Mark A	Mark B
		
Installation location	Installed to the motor with A mark on the arm	Installed to the motor with B mark on the arm

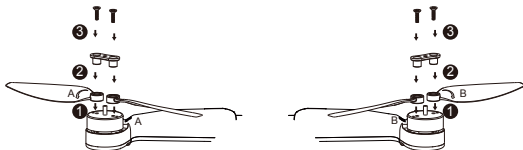

Install the propellers

- Taking the camera direction as the front, the left front arm and right rear arm must be installed with propellers marked with A; the right front arm and left rear arm must be installed with propellers marked with B. Use a screwdriver to install and make sure the screws are tightened.

Detach the Propellers

- Use the screwdriver to detach the propellers from the motors.



- Please use the propellers provided by Ruko, and do not mix propellers of different types.
- Please check whether the propeller is installed correctly and tightly before each flight.
- Please check to make sure that the propellers are in good condition before each flight.

3.5 Smart Flight Battery

- The F11PRO 2 smart flight battery has a capacity of 3200mAh, a rated voltage of 7.7V, and includes charge/discharge management features. This battery uses high-energy, large-capacity cells to provide strong support for the aircraft's flight time.

3.5.1 Battery Features

Balance Protection	Automatically balance the internal battery cell voltage to protect the battery.
Overcharge Protection	It can prevent the battery from being overcharged and causing serious damage to the battery. When the battery is fully charged, remove the charger device in time.
Over-discharge Protection	It can avoid damaging the battery due to over-discharge.
Short Circuit Protection	When the battery detects a short circuit, the output will be cut off to protect the battery.



- Please read carefully and strictly abide by Ruko's Requirements in this User Manual, Flight Guide & Safety Disclaimer, and stickers on the battery surface before using the battery. The user shall bear the consequences caused by failure to use it as required.

3.5.2 Install / Remove the Battery

• Install

Insert the smart flight battery into the battery compartment and push it down until you hear a "click" from the battery buckle, indicating that it pops up and locks. Make sure the battery is in place.

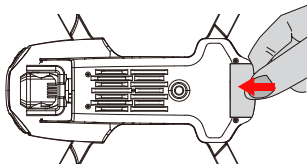

• Remove

To remove the battery, press the buckle on the bottom of the battery and pull the battery out of the compartment.

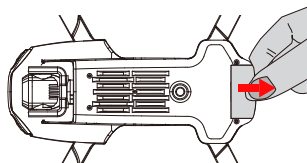

- Do not install the battery into the aircraft or remove the battery from the aircraft when the battery power is turned on. Otherwise, the poor contact of the battery interface during the operation may cause the battery to short-circuit and burn the aircraft.
- The battery must be installed or removed with the battery power turned off.

3.5.3 Powering On/Off

- Long press the power button to power on or off.

3.5.4 Checking Battery Level

- Long press the power button until all four bars of the indicator light up, then release the power button. After powering on, the power indicator shows the current battery level.

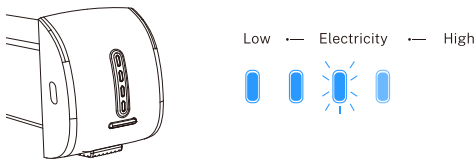

3.5.5 Charging the Battery

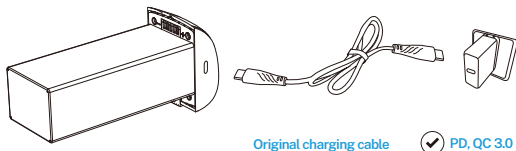

- Before using the smart flight battery, be sure to fully charge it.
- Please use the USB cable provided in the package for charging. Support PD, QC3.0 plug.
- In the charging state, the battery power indicator will flash and indicate the current charge level. When the fourth indicator light is always on, it indicates that the charging is complete.
- After charging is complete, please remove the charger in time.
- Charging time: 2.5 hours (using the Type-C fast charging cable that comes with the package).

3.5.6 Low Temperature Notice

- When using the battery in a low-temperature environment (32°F-41°F / 0°C-5°C), please make sure that the battery is fully charged. The flight time will be reduced as the discharge capacity of the battery will be reduced when working in a low-temperature environment.
- In a low-temperature environment, due to the battery output power limitation, the aircraft's wind resistance and flight performance will be reduced. Please be careful.
- Pay more attention when flying in low-temperature and high-altitude environments.

3.5.7 Daily Preservation Advice

- It is recommended to charge and discharge it once a month, do not store with a full charge, keep 50%-60% of the power, the storage temperature is 50°F-104°F (10°C-40°C), and the best storage temperature is 66.2°F-69.8°F (19°C -21°C).
- If water enters the battery and the battery protection board fails, the battery cannot be used normally. Do not use the battery in rain or in a humid environment, as this may cause the battery to self-ignite or even explode.
- If the battery is squeezed, deformed, and dropped from a high altitude, it is forbidden to use it again.
- Prolonged exposure to high temperatures is forbidden. High temperatures will cause the internal pressure of the battery to become too high and cause an explosion.
- The positive and negative poles are short-circuited for a long time (such as the battery contacts have water, short-circuit caused by hair or foreign objects, etc.). If it exceeds 30 minutes, the protection board IC will fail and disconnect, and the battery cannot be used normally.

- If the aircraft has not been used for a month, the battery must be removed to prevent the battery from being discharged for a long time.

3.6 Camera Overview

- The camera uses an upgraded 5.8GHz Wi-Fi FPV real-time transmission function, equipped with a 120°FOV lens and a 90° adjustable camera as well as 3-axis brushless gimbal, which can stably shoot 4K HD video and 6K ultra-clear images, providing you with a broad field of vision for unforgettable moments.

3.6.1 3-Axis Brushless Gimbal

- The F11PRO 2 is equipped with a three-axis mechanical stabilization gimbal, with roll, pitch, and yaw axes powered by brushless motors. This ensures stable and smooth image transmission.

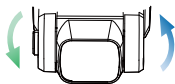

Roll Axis

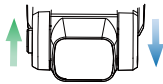

Tilt Axis

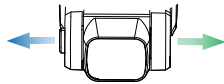

Yaw Axis

- The gimbal will not function and may appear tilted before it is powered on and completes its self-check. This is normal. Once powered on, the gimbal will automatically perform a self-check, which takes about 20 seconds. After the self-check, the gimbal will stabilize and level itself automatically.

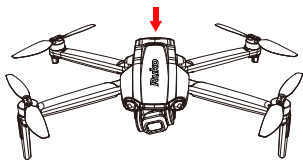

Before power on and
self-check
(Non-operational state)

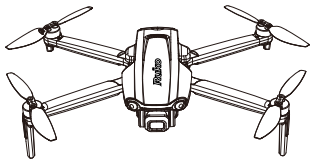

After powering on and
completing the self-check
(operational state)

3.6.2 The aircraft adjustment angle is -90° to 0°

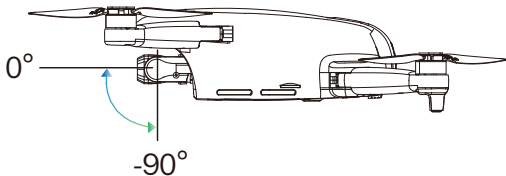

3.6.3 Image Storage

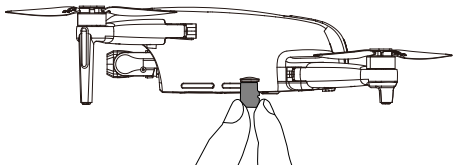

- The F11PRO 2 is equipped with a micro-SD card slot for expanding storage capacity. (SD card is not included in package)
 - ① Card speed: 10M/s.
 - ② File format: Support FAT32 format.
 - ③ Memory capacity: A memory card with a memory capacity of 128G or less.

F11PRO 2	Picture	Video
App	5700×3200P 4096×3072P 3840×2160P	1280×720P@25fps
SD card	5700×3200P 4096×3072P 3840×2160P	3840×2160P@30fps 2688×1512P@50fps 2688×1512P@30fps 2048×1080P@50fps



- Check whether the capacity of the memory card is sufficient. If the capacity of the memory card is insufficient, videos and pictures cannot be stored in the memory card.
- If you cannot save pictures or videos, try formatting the memory card.
- Do not insert or remove the micro SD card after the aircraft is powered on, as this may cause damage to the card or result in data loss.
- After the memory card is installed, the picture and video files will be stored in the memory card, and the pictures and videos will not be stored on the mobile phone.
- After powering on and connecting the aircraft, you can use the app to download photos or videos stored on the aircraft's memory card to your mobile device.

4 Remote Controller

4.1 Introduction

- F11PRO 2 remote controller uses the 5.8 GHz frequency band, and the remote controller distance is up to 10000ft (unobstructed and interference-free environment). The retractable handle can securely hold a phone and supports devices up to 6.7 inches in size.
- Remote controller built-in 3600mAh 3.7V capacity battery, charging time is 3.5 hours, and the longest working time is about 4 hours.

4.2 Remote Controller Instructions

4.2.1 Powering On/ Off

- Powering on: Short press then long press the power button.
- Powering off: Long press the power button.
- Check the remote controller's battery level: Short press the power button.

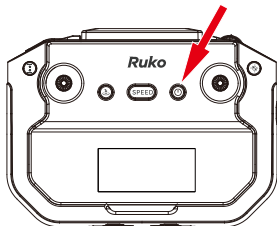

4.2.2 Charging

- Connect the remote controller Type-C port to the charger to charge it.

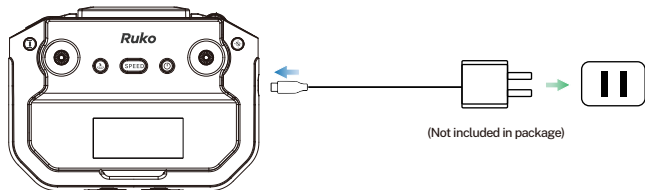

4.2.3 Controlling the Camera

- Record Button: Short press it to start/stop recording.
- Shutter Button: Short press it to take a photo.

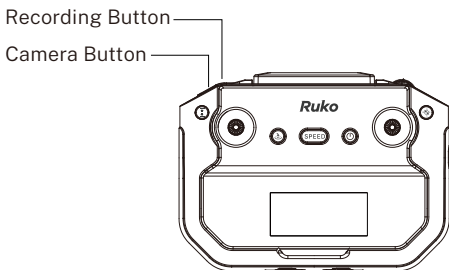

4.2.4 American stick mode and Japanese stick mode

- American stick mode for controlling the aircraft is as follows:

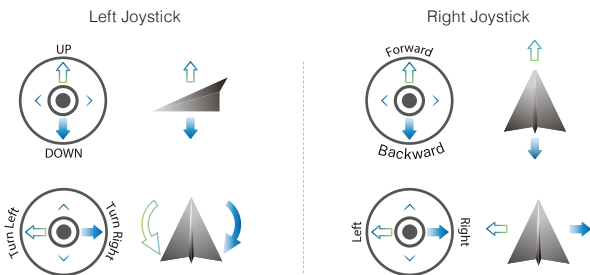



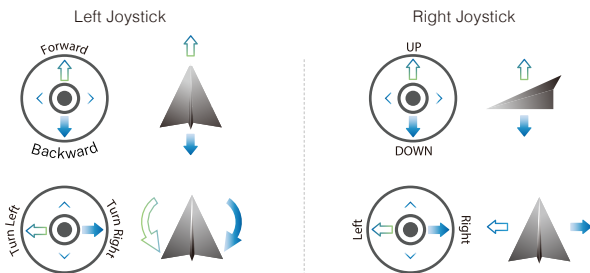



- Japanese stick mode for controlling the aircraft is as follows:

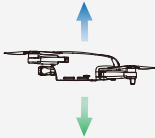
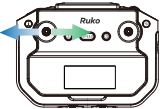

How to Switch

- Press and hold the record button to turn on the remote controller, it will be Japanese stick mode after turning on.
- It will back to the default American stick mode when turn off the remote controller and turn on again.

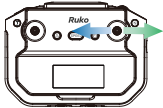
4.2.5 Remote Controller Joystick Operation Instructions

Remote Controller (Default American Stick Mode)	Aircraft Direction	Operation Instructions
		<ol style="list-style-type: none"> 1. Push the stick upward to make the aircraft ascend. 2. Pull the stick downward to make the aircraft descend. 3. When the stick is released and returns to the center position, the aircraft will hover. (When taking off, the left stick must be pushed upward to lift the aircraft off the ground. Push the stick slowly to prevent the aircraft from suddenly ascending too rapidly.)
		<ol style="list-style-type: none"> 1. Push the stick to the left, and the aircraft will rotate counterclockwise. 2. Push the stick to the right, and the aircraft will rotate clockwise. 3. The amount you push the stick controls the rotation speed of the aircraft. The further you push the stick, the faster the rotation.
		<ol style="list-style-type: none"> 1. Push the stick up to make the aircraft fly forward. 2. Push the stick down to make the aircraft fly backward. 3. When the stick is in the neutral position, the aircraft's forward and backward direction remains level. 4. When the aircraft moves forward or backward, the body will tilt forward or backward. 5. The amount you push the stick controls the flight speed; the greater the push, the larger the tilt angle and the faster the flight.
		<ol style="list-style-type: none"> 1. Push the stick left to make the aircraft fly to the left. 2. Push the stick right to make the aircraft fly to the right." 3. When the stick is in the neutral position, the aircraft's left and right direction remains level. 4. When the aircraft flies left or right, the body will tilt in the corresponding direction. The amount you push the stick controls the flight speed; the greater the push, the larger the tilt angle and the faster the flight.



• The forward direction of the aircraft is based on the direction of the nose.

4.2.6 Smart RTH Button

- Press the smart RTH button  on the remote controller to activate the automatic return-to-home function. Press it again to exit RTH. The aircraft will hover in place midway through the return journey when you exit, and you can then use the stick to control the aircraft.

4.3 Communication Range

- When operating the aircraft, adjust the position and distance between the remote controller and the aircraft as needed. Aim the remote controller directly at the aircraft to ensure it remains within the optimal communication range.

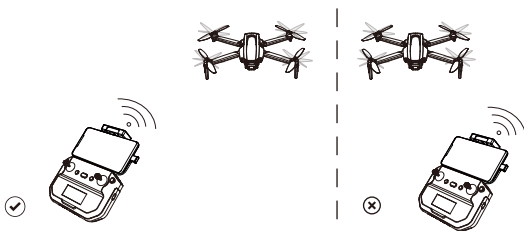

- The remote controller antenna is located in front of the phone mount. During flight, aim the phone mount directly at the aircraft to achieve the strongest signal transmission.
- User can refer to the aircraft flight direction from the Attitude Indicator in the app.

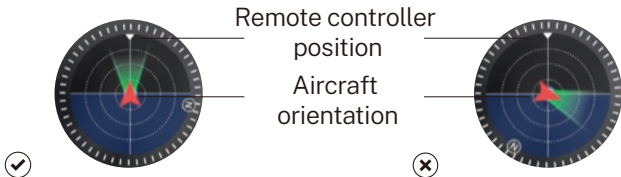

4.4 Remote Controller Pairing

- Before each flight, you need to pair the aircraft with the remote controller. Pairing takes about 20 seconds, and you can only operate the aircraft once pairing is successful. Follow these steps to pair:
 - (1) Turn on the aircraft.
 - (2) Turn on the remote controller.
 - (3) The aircraft and remote controller will pair automatically. During pairing, the remote controller will emit a 'beep-beep' sound. Pairing is complete when the sound stops.



- Once pairing is successful, the aircraft's LED light will change from blinking yellow to a solid red (indicating no GPS signal) or to a solid green (indicating GPS signal acquired).



- Before each flight, check the battery level of the remote controller. The remote controller will emit a warning sound when the battery is low.
- If the remote controller is idle for 10 minutes, it will automatically power off. To resume normal operation, move the joystick or press any button.
- When using the remote controller with a mounted device, make sure the device is securely clamped to prevent it from slipping.
- Store the remote controller with a battery level of around 3.8-3.9V. Charge the battery approximately every month to maintain its health.

5 Ruko Mini App

5.1 Home Screen

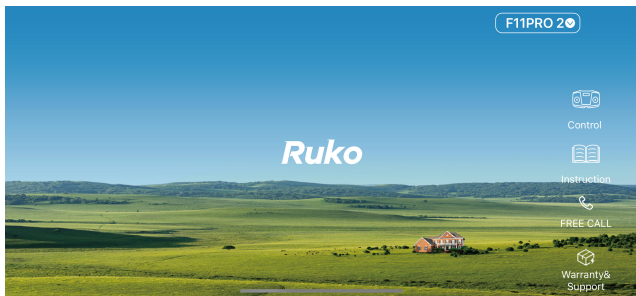

Control

- Use the buttons on the app interface to control the aircraft and view the live video feed from the aircraft's camera.

Instruction

- Tap to view the User Manual, Flight Guide, and Safety Disclaimer, as well as to access the flight instruction videos.

Free call

- Tap to Call Ruko Customer Service Support.

Warranty & Support

- Tap to access the support ticket page (warranty and support), where you can send text, photos, or videos to receive technical assistance.

5.2 Control Interface

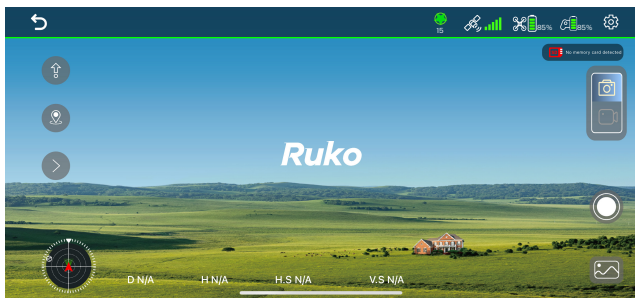

	Back		Shooting Mode
	Compass Interference Value		Shutter/Record Button
	GPS Status		Photo Album
	Aircraft Battery Level/ Remote ID Information		Attitude Indicator
	Controller Battery Level		More Features
	System Settings		RTH
	SD Card		Auto Takeoff/Landing
<p> D N/A H N/A H.S N/A V.S N/A </p> <p> Flight height Speed of vertical flight Speed of horizontal flight Flight distance </p>			



Remote controller battery level

- Display the current remote controller battery power, and the power progress bar displays.

Aircraft status indicator bar

- In flight: Display the flight status of the aircraft and various warning information.



GPS status

- Used to indicate GPS signal strength: 3 bars mean the GPS signal is strong enough for flight, while 1 or 2 bars indicate a weak GPS signal, requiring a change in takeoff location.



Aircraft battery level

- Display the current smart flight battery power, and the power progress bar displays.
- Tap the battery icon to view Remote ID information.

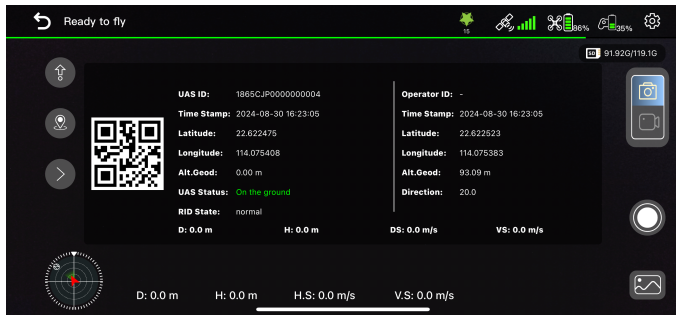

System settings







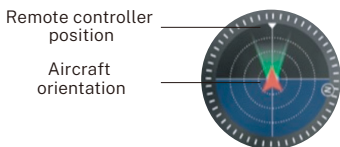



- System settings include flight range settings, data logging, unit switching, displaying flight paths, showing notifications, and configuring voice prompts.

Attitude indicator

- Displays information such as the aircraft's heading, tilt angle, and the positions of the remote controller and home point.



More Features

	GPS Follow	Aircraft will lock onto the user and can track the user's movement as he moves.
	Fly Around	The aircraft fly around in circle with the current position as the center.
	Route Planning	Aircraft flies along the path marked on the App.
	Split Screen	VR split screen interface, used with VR glasses.
	Lens Angle	Adjust the shooting angle of the aircraft camera.
	Recording	When it is turned on, your video will include ambient sound.
	Night Mode	Increase the brightness of the live feed in the app during night flights. It is recommended to enable this feature at night or in low-light conditions.
	Zoom	Optional 5x zoom.
	Filter	Select a filter for your photo or video.
	Vertical Screen	Switch the image to vertical to take photos and videos.

RTH

- Tap to initiate Smart RTH and have the aircraft return to the last recorded home point and turn off the motors. Tap it again to cancel the return.

One-key takeoff/landing

- After unlocking the motors, tap this icon to make the aircraft take off automatically; tap it again, and the aircraft will land automatically. You can cancel the descent by push up the throttle stick.

Back

- Tap to return to the homepage.

5.3 Parameter

- Tap the icon  to enter parameter interface

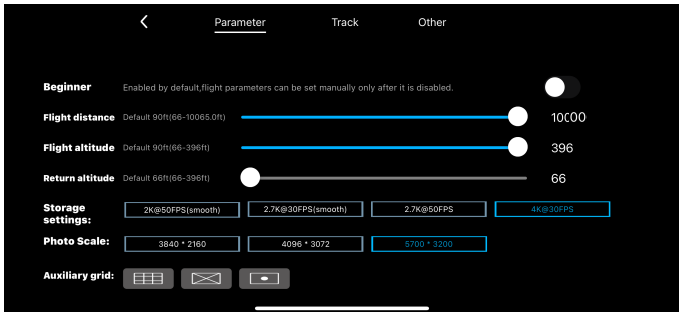

- **Beginner:** In this mode, the aircraft's farthest flight distance and altitude is 30 meters, so that the aircraft can fly more safely within sight.
- **Flight distance:** Set the longest distance to fly.
- **Flight altitude:** Set the maximum flight altitude.
- **Return altitude:** The default altitude of the aircraft during performing a return flight is 20 meters, and it is recommended to set the altitude higher than the height of the surrounding obstacles.
- **Storage settings:** Option to store video recordings of different resolutions on the SD card.
- **Photo Scale:** Optional picture shoots with different specifications.
- **Auxiliary grid:** Different auxiliary lines can be selected to assist in composing the shot.

5.4 Track

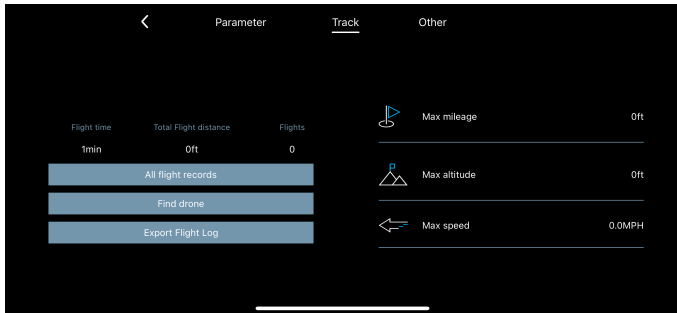

- Flight time: Total flight time
- Total Flight distance: Total flight distance
- Flights: Number of flights
- Max mileage: The longest single flight distance.
- Max altitude: The highest single flight altitude.
- Max speed: The fastest single flight speed.
- All flight records: Date, location, distance, duration, and maximum altitude for each flight.
- Find drone: Shows the last known location when the aircraft lost video transmission. Open the map to locate the position where the aircraft disconnected from the app.
- Export Flight Log: Allows you to export flight data. (Flight logs on iPhones are in .txt format, while on Android phones, they are in both .txt and .logbin formats.)

5.5 Other

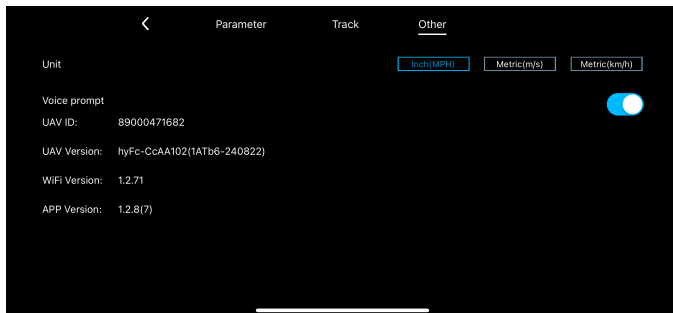

- Unit: Switch between metric and imperial measurement units.
- Voice prompt: Turn the app's voice prompts for aircraft status on or off.
- Drone Information Display: Shows the app version, Wi-Fi version, and ID number.



- Before using the Ruko Mini App, make sure to properly enable the required permissions:
 - (1) Allow Ruko Mini to access your location. Otherwise, features like Follow Me won't function.
 - (2) Correctly set up the options that appear after connecting the data cable to Ruko Mini.
 - (3) Grant permissions for other functions such as photo album access and recording.
- When using the Ruko Mini App on your phone, keep your device running smoothly by closing any unnecessary background apps.
- The maps used in the map interface need to be downloaded from the internet. Before using this feature, connect your mobile device to the internet to cache the map data.
- Please download the correct app, Ruko Mini, to ensure proper operation with the aircraft.

6 Flight

- After installing and preparing the product, please first complete flight training or practice (we recommend doing this in beginner mode). Choose an appropriate flying environment. The aircraft has a maximum flight altitude of 120 meters. Always adhere to local laws and regulations during flight. Be sure to read the 'Flight Guide and Safety Disclaimer' before flying to understand safety precautions.

6.1 Flight Environment Requirements

- Do not fly in severe weather conditions such as strong winds, snow, rain, or fog.
- Choose an open area free of obstacles for your flight location. Buildings, mountains, and trees can interfere with the aircraft's compass and GPS signals. It is recommended to fly in an open space with at least a 33ft (10m) radius free of obstructions. Flying at an altitude greater than 49ft (15m) is suggested to avoid ground obstacles and signal interference.
- Keep the aircraft within line of sight during flight, and stay clear of obstacles and crowds. When flying over water, maintain a distance of at least 9.8ft (3 meters) from the surface.
- Control signals can be disrupted by high-voltage power lines, communication towers, or transmission towers. Avoid flying near these areas.
- Fly at altitudes below 9842ft (3000 meters) to ensure the aircraft's barometric altitude hold function operates correctly.
- When GPS is active, the aircraft can achieve stable hovering, smart return-to-home, and smart flight functions. Without GPS, these functions will not work, and the aircraft may drift with the wind and fail to hover.

6.2 Pre-Flight Checklist

- Ensure that the remote controller, smart flight battery, and mobile device have sufficient power.
- Make sure the aircraft's arms are fully extended.
- Ensure the battery compartment cover is securely fastened and the smart flight battery is properly installed.
- Check that the propellers are not damaged, worn, or deformed, and that there are no foreign objects tangled in them. Ensure they are securely installed.
- Make sure GPS is enabled to avoid losing signal, and fly outdoors in an open area.
- Check that the data cable connecting the remote controller and mobile device is securely installed.
- After powering on, verify that all four motors start normally and that their speeds are consistent.
- Ensure the camera is clean.
- If replacing parts, always use original manufacturer components. Using non-original parts can pose a risk to the safe operation of the aircraft. For details on supported accessories, refer to the accessories support page in the appendix of the user manual.

6.3 Pairing Remote Controller with Aircraft

- Please refer to section 4.4.4.

6.4 Connect the Data Cable

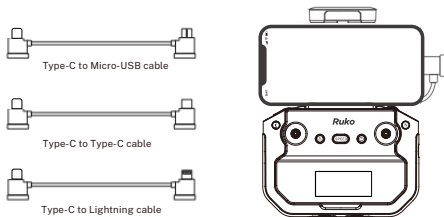

- Select the appropriate data cable.
- Use the data cable to connect the remote controller to the mobile device.
- Open the Ruko Mini App and allow popup permission requests.
- Enter the operating interface. If you see the aircraft' s live video feed, the connection is successful.



- When connecting the data cable to the mobile device, make sure the cable plug is securely installed. On some phones, the phone case may prevent the cable plug from seating properly, which can cause poor contact and result in failed data transfer, preventing you from seeing the live video feed.
- Type-C to Type-C data cable is stored inside the remote controller when shipped.



- Please set the USB options correctly when prompted: On Android devices, select 'Transferring Files /Android Auto'; on iPhones, select 'Trust'.

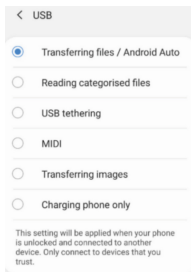
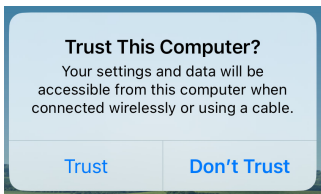

- On some Android devices, USB settings are hidden in the Developer Options. You need to enable Developer Mode and then change 'Default USB Configuration' to 'File Transfer' (the method to enable Developer Mode varies by phone model; you can find specific instructions by searching Google).

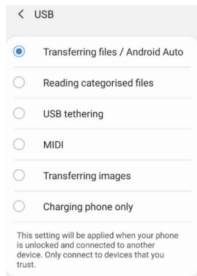
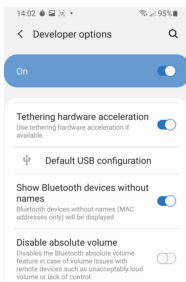

- The remote controller does not support fast charging for mobile devices. Please check the battery level of your mobile device before use.

6.5 Compass Calibration

- If the aircraft is flying in an environment with significant interference or if you experience unusual behavior indicating possible loss of control, you can check the compass interference level using the app. Perform a compass calibration to address this issue. The main purpose is to prevent sensor interference from causing abnormalities, which could lead to loss of control and potential crashes.

Calibration Steps:

- (1) Extend the aircraft's four arms and place it on a flat, open surface.
- (2) Turn on the aircraft and the remote controller, and ensure they are paired successfully.
- (3) Short press the compass calibration button on the remote controller; the aircraft's lights will start flashing quickly.
- (4) Open the app to see the calibration guide animation.

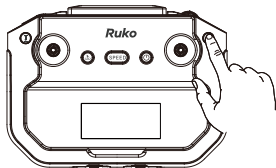

Short press to enter
compass calibration

Horizontal Calibration

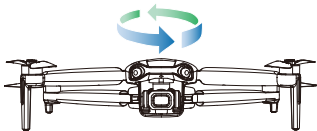

- Follow the app's instructions: Hold the aircraft at a height of 1 meter above the ground, rotate it horizontally 2-3 times until you hear a beep and the app indicates that it's time to begin vertical calibration.

Vertical Calibration



- Hold the aircraft to a height of 1 meter above the ground with the camera facing up. Rotate the aircraft vertically 2-3 times until you hear a beep and the animation on the app interface stops. This indicates that the compass calibration is complete. The aircraft's lights will return to their original state.



- Before flying, monitor the compass interference level in the app 📶. If the interference level approaches 120, it indicates excessive interference, you can manually calibrate the compass or choose a different location to fly. If the interference level exceeds 180, the aircraft will automatically enter compass calibration.
- If the aircraft exhibits uncontrolled behavior, such as spinning or erratic flight, in a complex environment, it may indicate that the compass calibration is incorrect or affected by interference. In this case, promptly land the aircraft manually and perform a manual calibration (refer to the compass calibration steps for guidance).
- When calibrating the aircraft, extend the arms and ensure the aircraft is at a height of 3.3ft (1m) above the ground to avoid magnetic interference.

6.6 Gyroscope Calibration

Gyroscope Calibration Steps:

- Ensure the aircraft is placed on a level surface with enough space below the camera.
- Push both the left and right control sticks to the '5 o'clock position simultaneously.

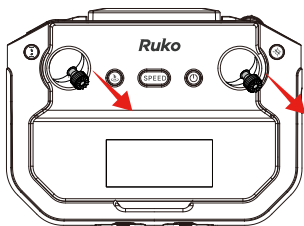

- Aircraft's lights will flash quickly, indicating that automatic horizontal calibration is in progress.
- When the app calibration prompt disappears and the lights return to their original state, calibration is complete.



- If the aircraft shows tilt or instability during flight, land the aircraft on a level surface to perform gyroscope calibration.
- When resetting the gyroscope calibration, make sure the aircraft is placed on a flat, level surface.

6.7 Starting/Stopping the Motor

6.7.1 Starting the Motors

Method 1:

Push the joysticks to the 5 o'clock and 7 o'clock positions simultaneously. Once the motors start, immediately release the joysticks.

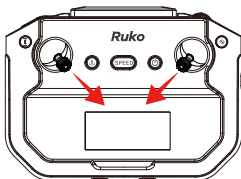

Method 2:

When the motors are not running, press and hold the takeoff/landing button on the remote controller to start them.

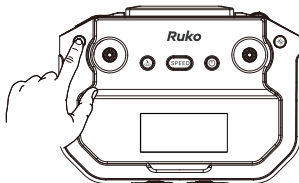

6.7.2 Stopping the Motors

- Push the throttle stick to the lowest position and do not release it until the motor stops.

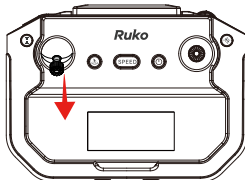

6.8 One-key Takeoff / Landing

6.8.1 One-key Takeoff

Method 1:

After starting the motors, press and hold the takeoff/landing button  on the remote controller. The aircraft will take off automatically and hover at a distance of 4.9ft (1.5m) from the ground.

Method 2:

Tap one-key takeoff icon  in App, then swipe right in the pop-up window. The aircraft will take off automatically and hover at a distance of 4.9ft (1.5m) from the ground.

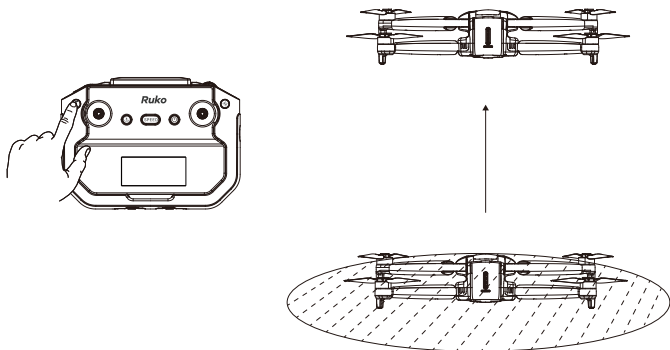

6.8.2 One-key Landing

Method 1:

After takeoff, press and hold the takeoff/landing button  on the remote controller. The aircraft will land to the ground and stop the motors.

Method 2:

Tap one-key landing icon  in App, then swipe right in the pop-up window. The aircraft will land to the ground and stop the motors.

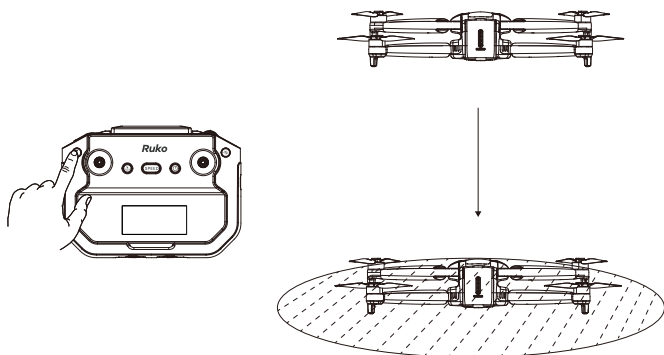

- During the aircraft's descent, pushing the throttle stick up on the remote controller will cancel the automatic landing.



6.9 Return to Home (RTH)

- The F11PRO 2 aircraft features a Return to Home (RTH) function in GPS mode when it has a strong GPS signal. This function returns the aircraft to the last recorded home point and lands it automatically. There are three types of RTH: Smart RTH, Low Battery RTH, and Lost Signal RTH.

6.9.1 Home Point Definition

	GPS	Description
Home Point		<p>During outdoor flights, when the GPS signal icon first shows three bars or more, the takeoff location will be recorded as the return-to-home point.</p> <p>During the flight, if you land at a new location, the new takeoff point will become the latest return-to-home point, and the return-to-home function will direct the aircraft to this latest point.</p>

6.9.2 Smart RTH

- When you need the aircraft to return home automatically, you can press the Smart Return-to-Home button  on the remote controller or tap the return-to-home icon  on the app interface to initiate automatic return.
- During the return-to-home process, pressing the button or tapping icon again will cancel the return. After canceling Smart RTH, you can regain control of the aircraft.
- During the Smart RTH process, you can maneuver the aircraft to ascend or descend to avoid obstacles. You can also press the RTH button again to cancel the return.

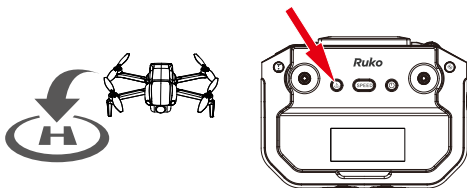

1. After clicking the return button, the aircraft will return to the destination in different ways depending on the flight distance, flight altitude, and whether the return altitude is set in the App. After pressing the RTH button on the remote controller or tapping the return icon on App:

(1) If the flight distance is within 16.4ft (5m):
The aircraft will land directly.

(2) If the flight distance is greater than 16.4ft (5m), and the return altitude is NOT set in App:

① When the aircraft's flight altitude is below 65ft (20m):
It will automatically rise to the default return altitude of 20m and then return to the Home Point.

② When the aircraft's flight altitude is above 65ft (20m):
It will return to the Home Point from the current altitude.

(3) If the flight distance is greater than 16.4ft (5m) and the return altitude has been set in the App:

① When the aircraft's flight altitude is lower than the set return altitude:
The aircraft will rise to the set return altitude and then return to the Home Point.

② When the aircraft's altitude is higher than the set altitude:
The aircraft will return to the Home Point from the current altitude.

2. The aircraft is not equipped with obstacle avoidance function, please make reasonable judgments of the flight conditions during the flight, avoid obstacles in time, and set the appropriate flight and return altitude according to the flight environment.

6.9.3 Low Battery RTH

- When the smart flight battery is too low or there is not enough power to return home, the user should land the aircraft as soon as possible to avoid damage to the aircraft or other dangers.
- To prevent unnecessary dangers due to insufficient battery power, the Low Battery RTH function will be automatically triggered when the aircraft battery power is low.
- According to the remaining power after starting returning, there are 2 situations:
 - ① First-level low battery:
After the aircraft triggers the Low Battery RTH, it will automatically return to the Home Point and hover. After hovering, it can continue to fly within a 98ft (30m) radius at a height of 98ft (30m).
 - ② Second-level low battery:
The aircraft will land directly to the ground.
- When the aircraft's battery is low, the remote controller will emit a sound. At First-level Low Battery, the remote controller will beep slowly. At Second-level Low Battery, the remote controller will beep rapidly.

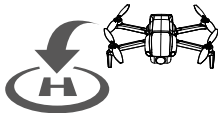

Low battery



- Must pay attention to the flight altitude when the battery is low. Avoid hitting obstacles due to the low flying altitude when returning home with the second-level low battery.
- The remaining power after returning is related to the return distance, wind speed, and wind direction.
- When the aircraft is low on battery and is returning home, you cannot cancel the return. You can use the remote controller stick to avoid obstacles.

6.9.4 Lost Signal RTH

- If the remote controller's battery is low, turned off, or lost signal for 10 seconds, the aircraft will enter automatic return-to-home mode and return to the Home Point.
- If the remote controller reconnects during the RTH process and you wish to cancel the return, you can press the RTH button to cancel it.
- Lost Signal RTH process:
 - (1) Record Home Point. (For information about the Home Point, refer to section 3.4.1.)
 - (2) Trigger RTH (triggered by low battery of remote controller, signal loss, etc.).
 - (3) After triggering the RTH, the aircraft adjusts the nose direction and starts to return home.
 - (4) The aircraft automatically flies to the Home Point, then starts to land, and completes the return.

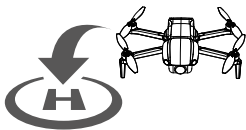

Signal Loss



- When out of control, the aircraft cannot avoid obstacles.
- When the GPS signal is weak, the aircraft cannot return to home automatically.

6.10 Smart Flight (Route Planning, GPS Follow, Fly Around, Cruise Control)

- F11PRO 2 has four types of smart flight: Route Planning, GPS Follow, Fly Around, and Cruise Control.

6.10.1 Route Planning

Aircraft flies along the path marked on the App.

How to Start

- Make sure that the Ruko Mini App has been downloaded and installed on the phone.
- Connect your phone to the remote controller with the data cable, and enter into the App operation interface.
- Make sure the map is loaded on the Ruko Mini App before taking off the aircraft.
- Take off the aircraft in GPS mode and ensure flight height is higher than the nearby obstructions.
- Tap the icon (📍) on the app interface to start the Route Planning.

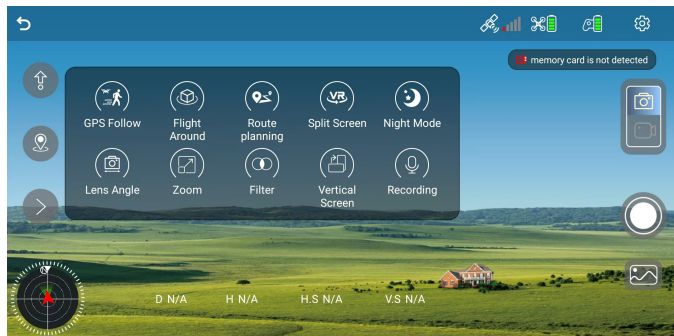

(6) You can find a red circle on the map (limited flight range). Mark the points (up to 10) which you plan to fly the aircraft along within the circle.

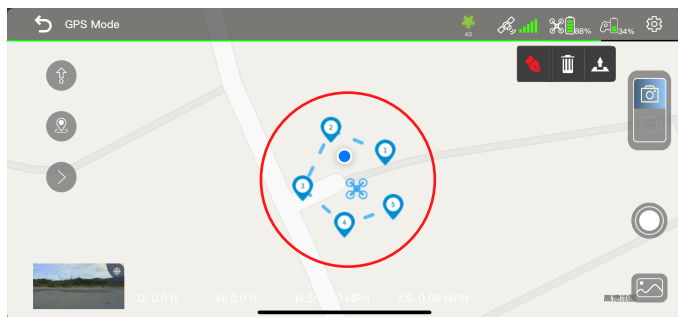

(7) Tap "Delete Single Point" or "Delete All" to reset the marked point.

(8) Confirm that the marked points are correct and tap "Go". The aircraft will start waypoint flight.



- If the current flight altitude of the aircraft is lower than 49ft (15m), Route Planning cannot be started.

How to Exit

Push the right joystick to cancel the waypoint flight function.

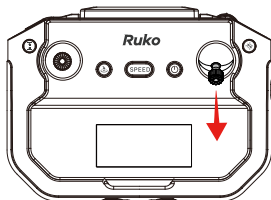

6.10.2 GPS Flow

- Aircraft will lock onto the user and can track the user's movement as he moves.

How to Start

- (1) Make sure that the Ruko Mini App has been downloaded and installed on the phone.
- (2) Connect your phone to the remote controller with the data cable, and enter into the App operation interface.
- (3) Take off the aircraft with a strong GPS signal and make sure the horizontal flight distance is 26.25ft-164.04ft (8m-50m).
- (4) Tap the icon  on the app interface to start the GPS Follow.
- (5) "Follow me mode is ready" will be displayed on the App interface and the aircraft turns on the "GPS follow". The aircraft will track your movements to fly.

How to Exit

Tap the icon  again to exit the GPS Follow.



- The GPS Follow function only works when the GPS signal is strong. Please avoid high buildings, trees, and areas where Wi-Fi signal might be interfered.
- Aircraft is not equipped with obstacle avoidance function. Please use it in open areas free of obstacles.
- To use this function, the positioning function of the mobile phone must be turned on, otherwise, the GPS Follow function unavailable.

6.10.3 Fly Around

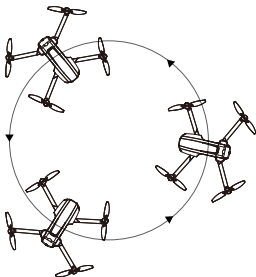

- The aircraft will fly around the target center point with a radius.

How to Start

- (1) Make sure that the Ruko Mini App has been downloaded and installed on the phone.
- (2) Connect your phone to the remote controller with the data cable, and enter into the App operation interface.
- (3) Take off the aircraft in GPS mode and make it hover around the center point of the target.
- (4) Tap the icon  on the app interface to start the Fly Around.
- (5) The aircraft will move backward 16ft (5m) (default orbit radius) and then use the position where the Fly Around function was initiated as the center to start the surrounding flight.
- (6) During the surrounding flight, the pilot can adjust the surrounding radius using the joystick (the radius range can only be between 16ft (5m) and 328ft (100m)). Pushing the joystick down will increase the surrounding radius while pushing the joystick up will decrease the surrounding radius.
- (7) By default, the aircraft performs surrounding flight in a counterclockwise direction. The pilot can change the surrounding direction by pushing the directional joystick left or right.

How to Exit

- Tap the icon  again to cancel the Fly Around.



- If the flight altitude is lower than 16ft (5m) when the Fly Around is activated, the aircraft will rise to 16ft (5m).
- The flying speed of the surrounding radius depends on the surrounding radius. The larger the radius, the faster the flight speed.

6.10.4 Cruise Control

- The aircraft automatically flies at a constant speed according to the current flight action.
- This function requires the use of GPS mode with a strong GPS signal.

How to Start

- (1) Set the desired auto-flight distance and altitude, fly the aircraft to an altitude above 49ft (15m) (it will be unavailable while below 49ft (15m)).
- (2) Keep toggling the left or right joystick to operate the aircraft forward, backward, ascent, or descent, then press the remote controller's one-key takeoff/landing button .
- (3) Release the joystick, the aircraft will fly automatically according to your action. (e.g., pushing the right joystick forward will make the aircraft fly forward automatically).
- (4) During cruise control, you can continue to use the joystick to adjust the aircraft's direction and altitude. Repeat steps 2 and 3, and the aircraft will automatically fly based on your last joystick input.

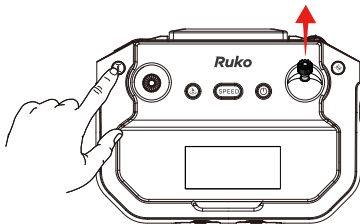

How to Exit

Method 1: During Cruise Control, pressing the one-button takeoff/landing  on the remote controller without operating the joystick will cancel cruise control.

Method 2: Tap the icon  on the App to exit it.



1. This function is unavailable when the flight altitude is below 49ft (15m).
2. This function is unavailable when the aircraft battery power is low. During cruising, if the aircraft's battery is low, it will automatically exit this function.
3. The aircraft will automatically exit this function after reaching the set distance.
4. When the aircraft is descending in cruise control and reaches an altitude of 50ft, it will automatically exit this function.
5. When the remote controller signal is lost, it will automatically exit this function.
6. The aircraft doesn't have obstacle avoidance functionality. Ensure flight safety by ensuring no obstacles in front of the aircraft to avoid collisions and damage.

6.11 Basic Flight

6.11.1 Basic Flight Steps:

- (1) Place the aircraft on a flat, open surface with the front of the aircraft facing forward and the rear facing the pilot.
- (2) Press and hold the power button to turn on the aircraft.
- (3) Short press then long press the power button on the remote controller to turn it on. The aircraft and remote controller will automatically pair, which takes about 20 seconds.
- (4) Once pairing is complete, connect the phone to the remote controller using a data cable.
- (5) Open the Ruko Mini app and enter the operating interface.
- (6) Wait for the GPS signal search to complete; the aircraft's indicator light will be solid green.
- (7) Unlock and start the motors.
- (8) Slowly push the throttle stick up to achieve a smooth takeoff.
- (9) Pull down the throttle stick to descend.
- (10) After landing, pull the throttle stick to its lowest position and hold it there until the motors stop.
- (11) After stopping the motors, turn off the power of the aircraft and the remote controller in sequence.

6.12 Aerial Photography Tips

- (1) Perform the pre-flight check.
- (2) It's recommended to take photos or record videos in Stable Mode.
- (3) Choose clear, calm weather for shooting.
- (4) During flight, make small, smooth stick movements to keep the aircraft stable.

7. Appendix

7.1 Specifications & Parameters

Aircraft	
Model	F11PRO 2
Weight (including battery)	About 357g/12.6oz
Battery capacity	3200mAh
Satellite system	GPS/GLONASS
Maximum flight altitude	393.7ft
Maximum flight distance	10000ft
Unfolded size	350mmx385mmx65mm
Folded size	165mmX90mmX65mm
Stable mode speed	6m/s
Sport mode speed	8m/s
Operating temperature range	32°F - 104°F (0°C - 40°C)

Gimbal Stabilization	
Mechanical range of gimbal stabilization	Tilt axis: approximately -100° to +70° Roll axis: approximately -35° to +35° Yaw axis: approximately -20° to +20°
Camera angle adjustment range	Approximately -90° TO +0°

Camera	
Lens	FOV 75°
Equivalent focal length	60cm/23.3inche
Focus range	Fixed focus
Maximum photo resolution	App: 5700×3200P
	SD card:5700×3200P
Maximum video resolution	App: 1280X720@25fps
	SD card: 3840×2160P@30fps
Photo format	JEPG
Video format	MP4
Supported file system	FAT32
Supported SD card	Micro SD card (Class 10/U1 or higher) 16GB to 128GB

5.8G Transmission	
Working frequency	5.725-5.825 GHz
Supported Transmission Protocols	802.11a; 802.11n20; 802.11n40

App / Live View	
Mobile App	Ruko Mini
Transmission range	10000ft (outdoor, open, interference-free environment)
Live view quality	1280x720@25fps
Mobile Compatibility	Android 7.1 and above, iOS 13.0 and above

Remote Controller	
Working frequency	5.8G
Remote controller range	Up to 10,000ft (outdoor, open, interference-free environment)
Battery capacity	3600mAh
Charging time	About 3.5 hours
Operation time	About 4 hours
Operating voltage	3.7V
Mobile device holder	3.5 inches
Operating temperature	32°F to 104°F (0°C to 40°C)

Smart Flight Battery	
Battery capacity	3200 mAh
Voltage	7.7V
Battery type	Li-polymer
Energy	24.64Wh
Net weight	About 126.5 g / 4.46 oz
Charging time	About 2.5 hours (using PD fast charging)
Charging temperature range	32°F to 104°F (0°C to 40°C)

7.2 Accessories Support

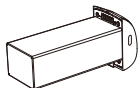

Battery



Propellers



Remote
controller

- All of the above accessories can be purchased by searching on Amazon and visiting the Ruko store. Be sure to use only original manufacturer parts. Using non-original parts may pose a risk to the safe operation of the aircraft.

7.3 Common Problems and Solutions

Problems	Reason	Solutions
Unable to unlock the motors and take off	GPS Signal Weak	To unlock and take off your aircraft outdoors, ensure it's in an open area and has acquired a sufficient GPS signal strength of 3 bars or more.
	Indicator flashing red	Ensure your aircraft is set on a level and smooth ground prior to taking off.
	Indicator flashing yellow quickly (10 times per second)	The compass is not calibrated. Please refer to the compass calibration section of the User Manual.
	The left and right control sticks not properly aligned	Push the left and right joysticks simultaneously to 5 o'clock and 7 o'clock for 2 seconds. Alternatively, you can use the remote controller or the app to activate the one-key unlock and takeoff feature.
Unstable flight	Flying too low, affected by aircraft airflow	Please fly the aircraft above 9.84ft(3 meters).
	Environmental disturbances cause aircraft data abnormal	Place the aircraft on a horizontal surface and conduct gyroscope/level calibration. Please refer to the User Manual for detailed instructions on the gyroscope/horizontal calibration section.
	The propellers become deformed and incomplete	Replace the propellers with new ones.
	GPS signal is unstable. Flying near buildings and in obstructed places	Please fly the aircraft in an open area free of obstacles within the circle of radius 32.81 ft(10 meters).
Not flying far, bouncing back after flying a distance	Beginner mode or first-level low battery is active, limiting flight to 30 meters in height and distance.	Enter the App setting interface, turn off the beginner mode to set the flight distance and altitude, and save the settings.
Aircraft flying in the opposite direction or mismatched to the remote controller	Incorrect aircraft placement during takeoff	Before takeoff, position the camera facing forward and the tail towards the pilot.
Out of control, spinning around on its own, abnormal noise	The remote controller signal is interfered or the aircraft exceeds the range of remote control	Please fly the aircraft outdoors without interference, and ensure that it is within a controllable range.
	Compass interference	Please manually land the aircraft in time and calibrate the compass. Please make sure to fly away from the buildings, trees, power lines, and signal towers.
	The propellers become deformed and incomplete	Replace the propellers with new ones.

Problems	Reason	Solutions
Gimbal not functioning	The aircraft takes off in the grassland, and the gimbal touches the grassland and fails the self-test	Add aprons or cardboard pads to pad the aircraft to avoid the gimbal bumping into foreign objects.
	Aircrafts takes off in areas with high vibration sources.	Keep away from vibrations and use in a vibration-free area.
	The aircraft's gimbal is interfered with by external human force, or the aircraft is picked up during the calibration process	Gimbal self-test time typically lasts about 40 seconds, avoid touching during calibration.
	The aircraft has entered into the compass calibration	During the calibration period, the gimbal is inactive. Once calibration is complete, place the drone on a level surface and it will automatically calibrate itself.
Video freezing, short image transmission range	Image transmission signal interference	Please make sure to fly away from the buildings, trees, power lines, and signal towers.
	The remote controller and the mobile phone are not pointed at the direction of the aircraft	Adjust the remote controller and the flying direction of the aircraft, ensuring the strongest signal connection is maintained
	Phone performance freezes	Close unused apps running in the background to maintain the best performance of the phone
App does not display the interface	The phone is not connected to the aircraft	Connect your mobile phone to the remote controller with the data cable.
	The data cable is not securely installed	Some phones come with a phone case resulting in abnormal installation of the data cable, which can be attempted by removing the phone case.
	USB permissions set incorrectly	After successful pairing, the USB permission setting will pop up after connecting the phone and remote controller cable, please set it correctly.
	The aircraft did not pair with the remote controller	It takes about 20 seconds for the aircraft to start pairing with the remote controller, and the aircraft screen will be displayed only after the pairing is successful.
App crashing or malfunctioning	Downloaded the wrong APP	Download the right APP.
	Phone version is too old and not compatible with the App	Give us your mobile phone version model and we will give you a corresponding solution
Weak GPS signal	Turning on the aircraft indoors	GPS signals cannot be found indoors. Please search for GPS signals in an open place outdoors.
	Under the tree, next to the building, in an obstructed place	Please stay away from obstacles for more than 32.81 feet(10 meters), and search for GPS signals in an open area

Problems	Reason	Solutions
Unable to return home, drifting away	Turned off the GPS signal and switched to indoor flight mode	Don't turn off GPS during outdoor flights, and make sure to promptly switch back to GPS mode
	Flying near buildings or under trees can obstruct GPS signals, leading to loss or instability of GPS	Fly away from buildings or sheltered areas
Long pairing time for the aircraft and remote controller	It takes about 20 seconds to match the remote controller to the aircraft	Please be patient and wait for the auto-pairing to be completed.
Unable to charge or not charging fully	Using inferior charger or charging on the computer with unstable voltage output	Use high-quality charging connectors and cables.
	Using inferior charging cables	Please use the original factory charging cable to charge.
Short battery life	Flying in windy weather	Flying in windy weather will accelerate power loss
	The battery is not fully charged	Please use a correct charger, and fully charge the battery
	Flying in sport extreme speed	Depending on personal operating preferences, using the sport speed for flight can impact the battery life
	Flying in cold weather	In low-temperatures, the chemical reaction of the lithium battery is slowed down and the energy cannot be fully released.
Product has slight marks	We tested all aircraft before shipping	In order to give you the best experience, we tested functions of all aircraft before shipping. Therefore, it is inevitable that there will be slight traces. However, it can be guaranteed that all aircraft are 100% brand new

This User Manual is subject to updates without notice.

For the latest version of the User Manual, please visit the official Ruko website.

<https://www.rukotoy.com/>

If you have any questions or suggestions about the User Manual, please contact us via the following email:

Rukodrone@gmail.com

Ruko is a trademark of Shenzhen Ruike Innovation Technology Co.,Ltd

Copyright ©2024 Ruko All Rights Reserved.

Ruko[®]

rukotoy.com

CONTACT US FOR MORE TECH SUPPORT

 +1 (888)892-0155 | Mon-Fri 7:00AM - 7:00PM (PST)

 +1 (732) 207-0697  rukodrone@gmail.com

