



BUN WARMERS
8018-BW, 8027-BW, 8033-BW, 8036-BW,
8045N-BW, 8045W-BW, 8045W-BWS, 8055-BW & 8075-BW
INCLUDES 120 & 220 VOLT MODELS
OPERATING AND MAINTENANCE INSTRUCTIONS

INTRODUCTION

1. Please read instructions before using.
2. Clean machine thoroughly before and after all uses using cleaning instructions below.
3. This machine will be HOT during use and for a short time after it is turned off – BE CAREFUL.

SAFETY INSTRUCTIONS

1. Plug electrical cord into a certified electrical outlet with a corresponding voltage rating as listed on the machine model labels.
2. Always unplug the electric cord before cleaning, adjusting or maintaining this machine. Do not operate with a damaged cord or plug or after the machine malfunctions, has been dropped or damaged. Use authorized service for examination, electrical or mechanical adjustment or repair.
3. This machine will be HOT during use and for a short time after it is turned off – BE CAREFUL. To avoid burns, do not let bare skin touch hot surfaces. Keep combustible materials away from warmer.
4. Extreme caution is necessary when any appliance is used by or near children and whenever the appliance is left operating and unattended.
5. This appliance is not intended for use near or around water. Never locate appliance where it may fall into a water container.
6. Never move unit while there is water in the pan(s).

PREPARATION

1. Set unit on a flat surface and remove the protective film the unit before use.
2. Position warmer near the power outlet. Avoid the use of extension cords. Do not run cord under carpeting or cover with runners or the like. Arrange cord where it will not be tripped over.
3. This appliance has hot and live electrical parts inside. Do not use it in areas where gasoline, paint or flammable liquids are used or stored.
4. If unit fails to work properly when first operated call NEMCO customer service at 1-800-782-6761

STARTUP

Pour approximately 2 cups of water into the bottom of the pan(s). Water should not come up over the false bottom.

ELECTRICAL REQUIREMENTS

Refer to the product tag (serial plate) on the back of the unit for voltage and wattage requirements. Be sure to plug unit into outlet with sufficient power.

OPERATION

1. Set machine clear of other equipment and fill with water as stated above.
2. Place buns, in bags (recommended), on FALSE BOTTOM in bottom of pan.
3. Plug the electric cord into a 3-wire outlet, 110-volt. Do not use a 2-prong adapter.
4. Turn machine on with ROCKER SWITCH.
5. Set THERMOSTAT to the preheat position. It takes approximately 10 minutes for warm-up.
6. Turn THERMOSTAT to desired position. (This is usually somewhere between LO & HOLD)
7. For more heat & humidity set thermostat knob at a higher position.

CLEANING

NOTE: Proper maintenance plays an important part in the life span and functioning of the warmer.

1. **Turn THERMOSTAT to low and unplug the power cord.**
2. Do not immerse warmer in water or other liquid.
3. Remove the FALSE BOTTOM from the bottom of the pan(s) & then remove the pan(s).
4. Remove the pan by pulling up on the front of the pan and then sliding out of the drawer.
5. Clean both the false bottom and the pan with warm soapy water.
6. Wipe the inside of warmer. **CAUTION IF THE MACHINE WAS RECENTLY USED THE ELEMENT MAY STILL BE HOT.**
7. Wipe the outside of warmer.
8. Dry off all parts and re-assemble by reversing the steps stated above.

TROUBLESHOOTING

Won't Heat	Check that unit is plugged in and power switch turned on.
	Check that thermostat is turned to desired heat setting.
	Check power source for proper voltage and that receptacle is working. If properly working and still no heat, call Nemco Customer Service at 1-800-782-6761.
Unit Blows Fuse or Circuit Breaker	Check to make sure circuit is not overloaded.
Food Product dry or hard	Check to make sure pan has water.
	Reduce heat.



8018-BW

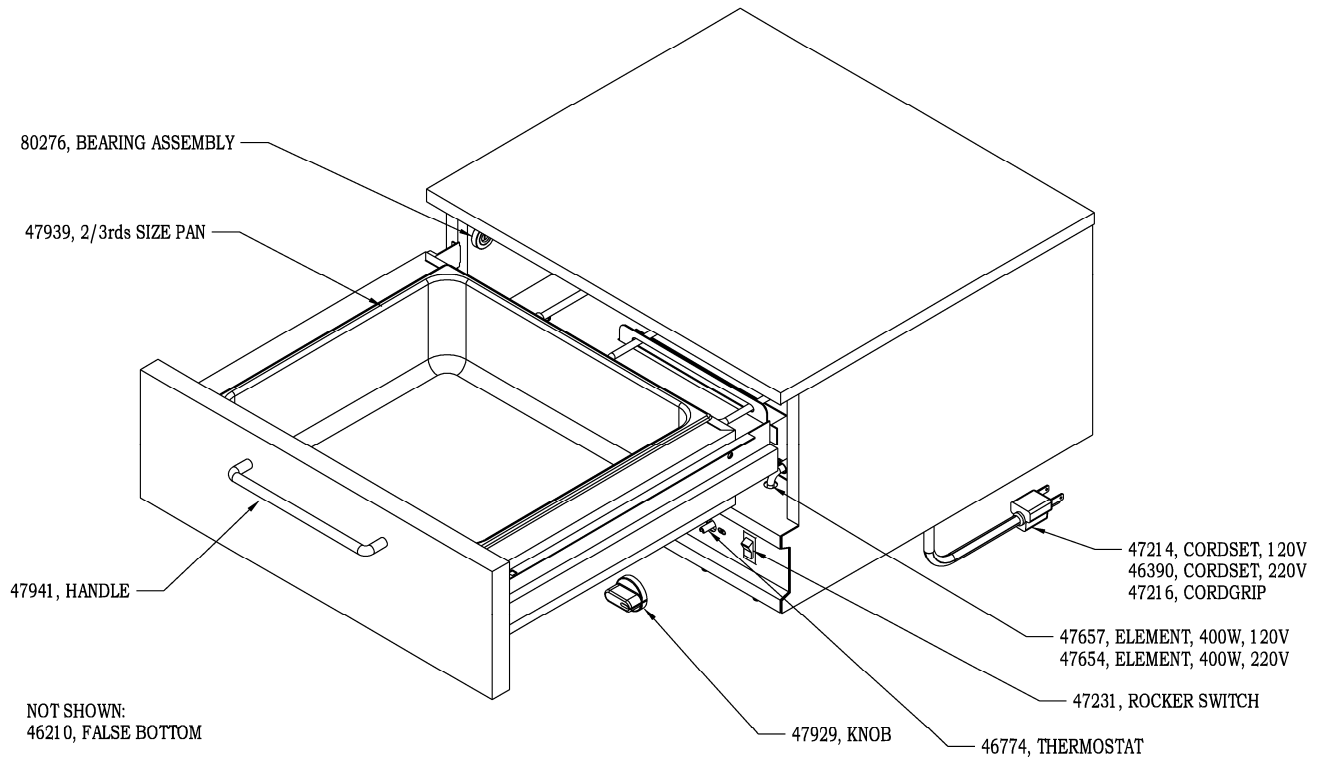

8027-BW 8033-BW 8045N-BW

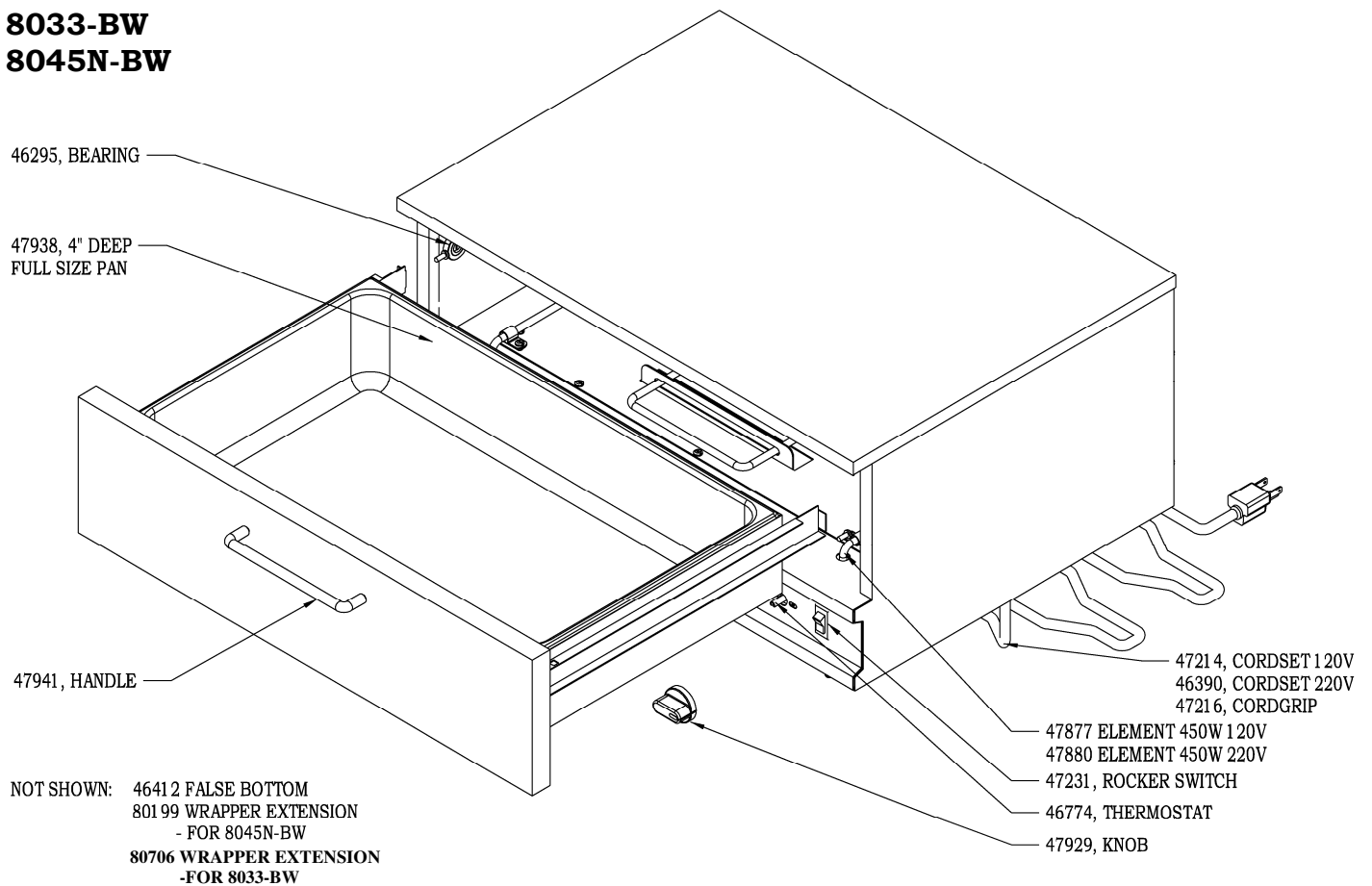

8036-BW

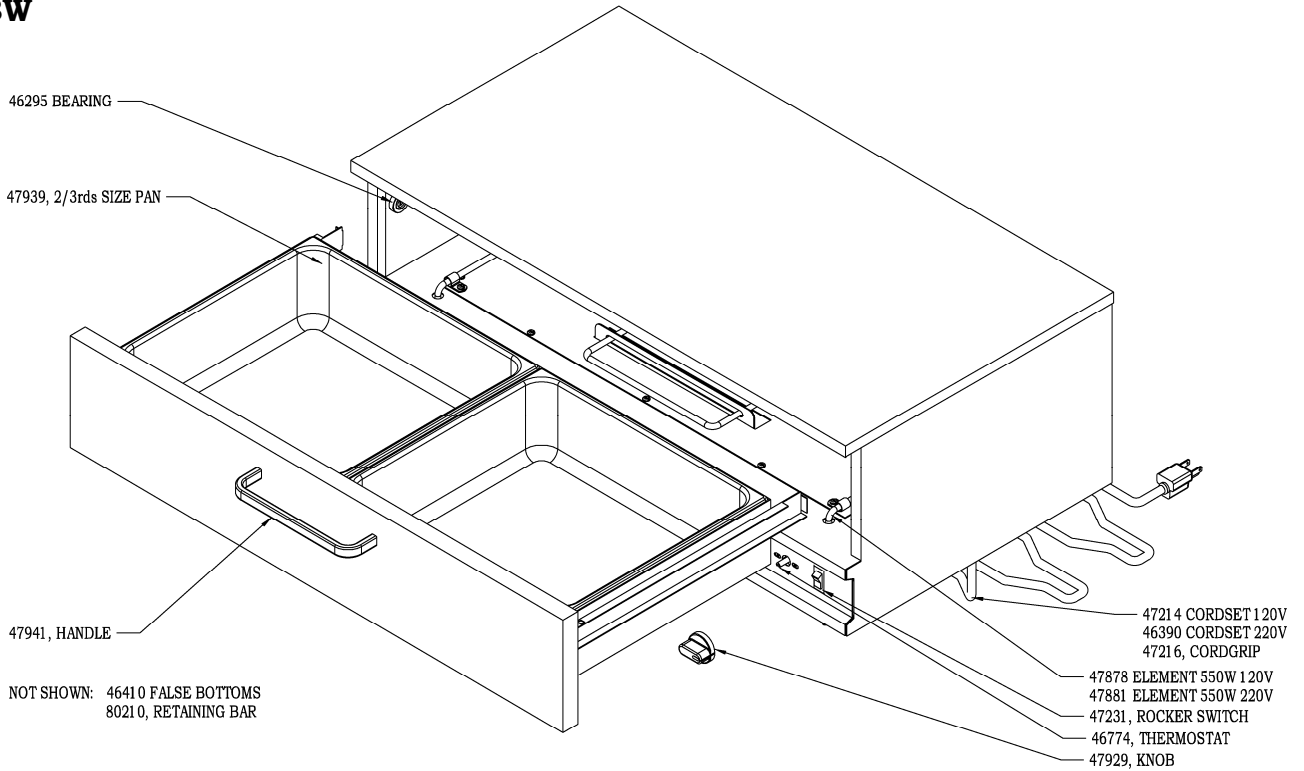

**8045W-BW & 8045W-BWS
8055-BW
8075-BW**

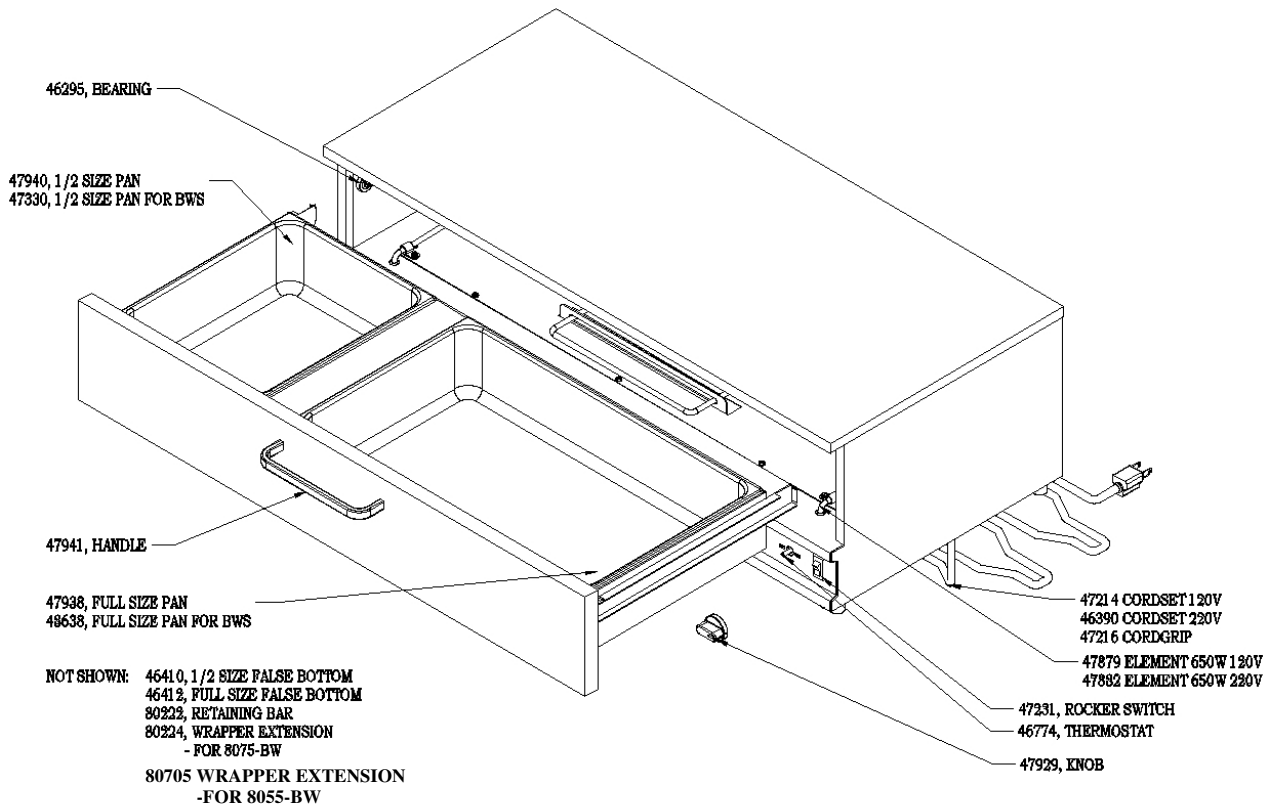

NEMCO FOOD EQUIPMENT

301 Meuse Argonne, Hicksville, OH 43526

1-800-782-6761 Toll Free 419-542-6690 Fax

www.nemcofoodequip.com



46012
12/19/2013

