



**Drop-in BBQ & Side Burner' User Manual**  
**Outdoor & Indoor**  
**4000DG-SL-SS/BLK | SMA-DSG0010-SS/BLK**



# Welcome to the Art of Outdoor Cooking

Congratulations on becoming the proud owner of a Smart BBQ! Thank you for choosing Smart, and welcome to the Smart family.

This instruction manual is designed to provide you with a comprehensive overview of the features your Smart BBQ offers. It will guide you in making the most out of your new appliance.

## KEEP THE DOCUMENTATION OF THESE PRODUCTS FOR FUTURE REFERENCE.

**Note:** This user manual is prepared for more than one model. Some of the features specified in this Manual may not be available on your appliance.

**THIS APPLIANCE SHALL BE INSTALLED IN ACCORDANCE WITH THE REGULATIONS FORCE AND ONLY USED IN A WELL-VENTILATED SPACE. READ THE INSTRUCTIONS BEFORE INSTALLING OR USING THIS APPLIANCE**



PLEASE DO NOT INSTALL YOUR SMART BBQ IF IT IS DAMAGED. UPON RECEIVING YOUR NEW BBQ, CAREFULLY INSPECT IT FOR ANY SIGNS OF DAMAGE. IF YOU NOTICE ANY ISSUES, CONTACT OUR CUSTOMER SERVICE IMMEDIATELY FOR ASSISTANCE. ENSURING YOUR BBQ IS IN PERFECT CONDITION BEFORE INSTALLATION IS CRUCIAL FOR YOUR SAFETY AND OPTIMAL PERFORMANCE OF THE APPLIANCE.

IF THE SUPPLY CORD IS DAMAGED, IT MUST BE REPLACED BY THE MANUFACTURER OR ITS SERVICE AGENT OR A SIMILARLY QUALIFIED PERSON IN ORDER TO AVOID A HAZARD.



THIS APPLIANCE IS CONCEIVED FOR DOMESTIC USE ONLY. THE MANUFACTURER SHALL NOT IN ANY WAY BE HELD RESPONSIBLE FOR WHATEVER INJURIES OR DAMAGES ARE CAUSED BY INCORRECT INSTALLATION OR BY UNSUITABLE, WRONG OR ABSURD USE.



THIS APPLIANCE IS NOT INTENDED FOR USE BY PERSONS (INCLUDING CHILDREN) WITH REDUCED PHYSICAL, SENSORY OR MENTAL CAPABILITIES, OR LACK OF EXPERIENCE AND KNOWLEDGE UNLESS THEY HAVE BEEN GIVEN, SUPERVISION OR INSTRUCTION CONCERNING USE OF THE APPLIANCE BY A PERSON RESPONSIBLE FOR THEIR SAFETY. CHILDREN SHOULD BE SUPERVISED TO ENSURE THAT THEY DO NOT PLAY WITH THE APPLIANCE.

Scan to register  
or request a service/repair



# Contents

<b>Product Description</b>	<b>5</b>
Components	
Technical Data	
<b>Important Safety Instructions</b>	<b>9</b>
Warnings / Dos / Donts	
<b>Assembling the BBQ</b>	<b>15</b>
Drop-in BBQ	
Drop-in Side Burner	
<b>Gas Connection</b>	<b>19</b>
Natural Gas Conversion	
<b>Gas Cylinder Safety Information</b>	<b>22</b>
Leak Test	
<b>Installation Procedure</b>	<b>25</b>
Drop-in BBQ	
Drop-in Side Burner	
<b>Electrical Components</b>	<b>28</b>
<b>Indoor Installation Instructions &amp; Warnings</b>	<b>29</b>
<b>Outdoor Installation Instructions &amp; Warnings</b>	<b>32</b>
<b>Alfresco Checklist</b>	<b>34</b>
<b>Igniting the BBQ</b>	<b>36</b>
<b>Cleaning and Care</b>	<b>38</b>
<b>Maintenance</b>	<b>41</b>
<b>Troubleshooting</b>	<b>43</b>
<b>Warranty Registration</b>	<b>44</b>

# Important Information







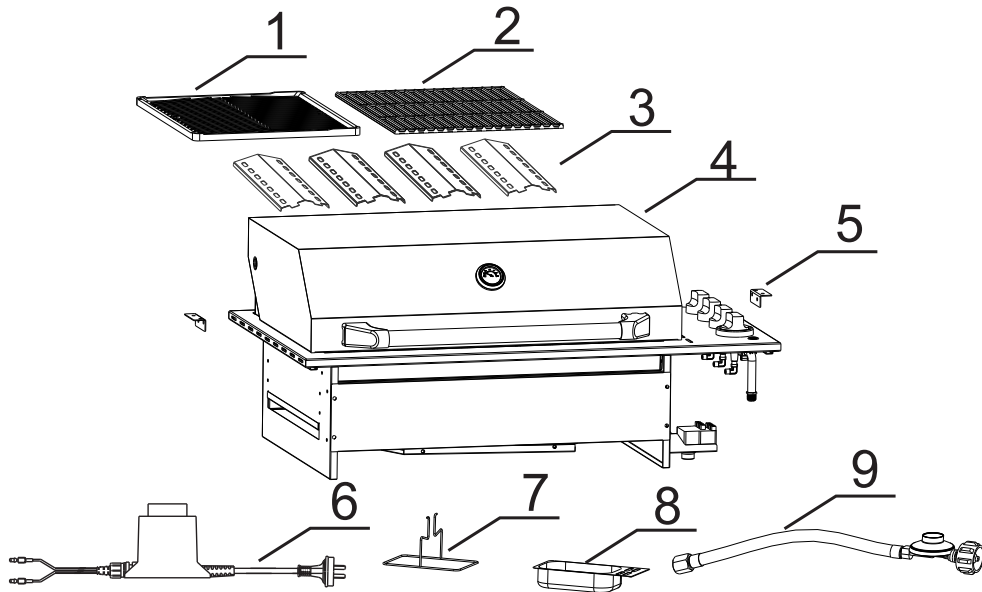

The **Smart BBQ** is certified for both outdoor and indoor installation under certificates AGA 9106 (outdoor certification to 5263.1.7) and GMK10936 (indoor certification to 5263.1.1) issued by IAPMO. Some differences exist re-installation requirements for indoor and outdoor use:

1. Installation requires a 1200mm clearance between the BBQ cooking surface and the range-hood.
2. See page 46-47 for more information on interlock installation.
3. Domestic installations using LPG gas must be made using residential LPG connections.

# Product Description

## Expanded View & Parts list for Smart Drop-in BBQ – 4000DG-SL-SS/BLK



#		Description	QTY	#	Description	QTY	
1		Solid Cast Iron Grill Plate	1	6		Transformer Cable	1
2		Open Cast Iron Grill Plate	1	7		Oil tray holder	1
3		Stainless Steel Flame Diffuser	4	8		Oil tray	1
4		BBQ Skin	1	9		LPG Gas regulator	1
5		BBQ Drop-in Handle	2				

**Expanded View & Parts list for Smart Side Burner BBQ – SMA-DSG30010-SS/BLK**  
(Outdoor only)

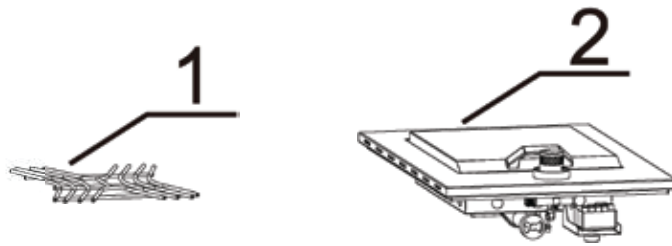

#		Description	QTY
1		Stainless Steel Cooking Grid	1
2		Side Burner Skin	1

# Technical Data

## FOR ELECTRICAL COMPONENTS

**AC Adaptor:** Input: 230-240VAC, 50Hz  
Output: 12VAC 5000mA

**Cord:** 250V, 10A

## DROP-IN

**Model No:** 4000DG-SL-SS/BLK

**Gas Type:** Universal LP Gas & Natural Gas

**Test Point Pressure:** Universal LP Gas – 2.75 kpa  
Natural Gas – 1.0 kpa

**Total Nominal Gas Consumption:** Universal LP Gas-44 MJ/h  
Natural Gas-42MJ/h

## NOMINAL GAS CONSUMPTION & INJECTOR SIZE:

Universal LPG Gas	Main Burners: 11MJ/hx4	Injector size: 0.98mm
Natural Gas	Main Burner: 10.5MJ/hx4	Injector size: 1.50mm

**IAPMO Approval No:** GMK10936

## SIDE BURNER

**Model No:** SMA-DSG0010-SS/BLK

**Gas Type:** Universal LP Gas & Natural Gas

**Test Point Pressure:** Universal LP Gas – 2.75 kpa  
Natural Gas – 1.0 kpa

**Total Nominal Gas Consumption:** Universal LP Gas-11.5 MJ/h  
Natural Gas-12.5 MJ/h

## NOMINAL GAS CONSUMPTION & INJECTOR SIZE:

(Outdoor only)

Universal LPG Gas	Main Burner: 11.5MJ/hx1	Injector size: 0.98mm
Natural Gas	Infrared Main Burner: 12.5 MJ/hx1	Injector size: 1.65mm



### CAUTION

- Always keep cord and electrical components dry
- Conversion of natural gas only to be done by authorised person
- The maximum cylinder size for use with this BBQ is 9kgs
- The thread type of this appliance is G1/4B-19

# Important Safety Instructions

## FOR YOUR OWN SAFETY, YOU SHOULD READ THIS MANUAL BEFORE OPERATING THE BARBECUE

Carefully read the user manual and keep it in a handy place for future reference. Below, we explain the meaning of the symbols used in this manual:



### ATTENTION

This symbol indicates information relating to the user's personal safety



### WARNING

This symbol indicates information on how to prevent damage to the appliance



### TIPS & INFORMATION

This symbol indicates tips and information about the use of the appliance



### SUGGESTIONS FOR THE ENVIRONMENT

This symbol indicates information for the economical and ecological use of the appliance



### DO NOT

This symbol indicates prohibited action



### ATTENTION

**THIS APPLIANCE MUST ONLY BE INSTALLED AND SERVICED BY QUALIFIED AND AUTHORIZED PERSONNEL. IMPROPER INSTALLATION, MODIFICATION, ADJUSTMENT OR MAINTENANCE CAN CAUSE PERSONAL INJURY OR PROPERTY DAMAGE. CONTACT YOUR NEAREST SERVICE CENTRE FOR FURTHER INFORMATION.**

### Note for the Installer:

#### THIS MANUAL MUST BE LEFT WITH THE OWNER FOR FUTURE REFERENCE

Only use a licensed gas fitter to install this barbecue and other trades as applicable; electrician, carpenter, bricklayer. Please remove all transit protection prior to installation and lighting BBQ.



Do not lean over barbecue while lighting



Do not leave the barbecue unattended when it is on



Do not delay ignition once the gas is opened



Do not store or use aerosol sprays near the barbecue



Do not store inflammable liquids near the barbecue



Do not use abrasive or caustic detergents on the barbecue



Do not use an open flame to check for leaks



Do not modify the structure of the appliance and do not modify the dimensions of the injector orifice



Do not obstruct the ventilation openings of the barbecue



Do not allow children to operate the barbecue or play near it



Do not delay ignition once the gas is opened



Do not store or use aerosol sprays near the barbecue



Keep any electrical wires and fuel hoses away from hot surfaces



Never store a spare gas cylinder near the barbecue



Do not use or store flammable materials near this appliance



Do not spray aerosols in the vicinity of this appliance while it is in operation



Do not use this appliance as a space heater



Do not modify this appliance



Do not place articles on or against this appliance



This appliance reaches high temperatures. Be especially careful when children and elderly persons are present



Never attempt to extinguish a flame/fire with water: turn off the appliance and cover the flame with a cover or a fire blanket



(For LPG installation only)  
Be careful when handling gas cylinders even if they appear empty, in compliance with current safety rules



Do not use dented or rusty gas cylinders



(For LPG installation only)  
Do not disconnect the gas cylinder from the appliance when it is on. Perform any service on the gas cylinder far away from the appliance



Only turn the burners on with the cover lifted



If the knob becomes difficult to rotate, have the taps checked by an authorized service centre



Lower the cover, accompanying it with your hand and make sure that nothing is obstructing its proper closure



(Applies to models with hooded lid - Outdoor use)  
When cooking with the cover closed keep an eye on the thermometer. If the temperature exceeds 350°C, lift the cover to prevent dangerous overheating



Do not leave objects on the cooking surfaces



Never use the appliance to heat the area



(For LPG connections)  
Always close the inlet connection / manual shut off valve after use (for Natural Gas connections) or always close the valve of the gas cylinder after use



Use Appliance with gloves on



Do not attempt to disassemble or adjust the control valves



Do not attempt to disassemble or adjust the cylinder regulator but, if necessary, replace with a new one



Do not use plastic or glass utensils on BBQ



Do not use the BBQ in strong winds



Do not test with gas leaks on a naked flame



Do not store gas cylinders in the cabinet



Do not lay the gas cylinder down (always keep upright)



Do not modify the constructions of the appliance or the size of the burner, injector orifice or any other components



Do not move appliance during operation



Do not obstruct any ventilation of the appliance



Do not use charcoal or any other fuel in the BBQ



Do not disconnect any gas fittings while the BBQ is being used



Do not fill the gas cylinder beyond 80% capacity



Use spanner to tighten all gas fittings



Check all gas hose and line connection for damage, cuts or cracks each time for using the appliance



Always leak test with soapy water



Check all burners regularly for insect nets such as spiders, ants, etc. Nets are dangerous and need to be fully cleaned



Have the gas cylinder filled by an authorized gas supplier



Always wear protective gloves when handling hot component



Clean and maintain the appliance after each use



USE grill at least 1.5 m from any combustible material, gasoline, flame liquids or vapors



"Burning off " the barbecue after every use (for approx 15 minutes) will keep excessive food residue to a minimum

## SAFETY PRACTICE TO AVOID INJURY

- Inspect the gas supply hose prior to turning on the gas. If there is evidence of cuts, wear, or abrasion, it must be replaced prior to use.
- Only the pressure regulator and hose assembly supplied with the appliance should be used. Never substitute regulator for those supplied with the appliance. Contact customer service for proper replacement.
- Leak checks the hose and regulator connections with a soap and water solution before operating the appliance.
- DO NOT turn the gas at the LP gas cylinder unless the gas hose is properly connected to the side burner gas pipe system and all burners are in the "OFF" position.
- Keep a spray bottle of soapy water near the appliance and check the connection before each use.

When properly cared for, your appliance will provide safe, reliable service for many years. However, extreme care must be used as the appliance intense heat that can increase accident potential.

When using this appliance basic safety practices must be followed, including following:

- Do not repair or replace any part of the grill unless specifically recommended in this manual. All other services should be referred to a qualified technician.
- The appliance is not intended to be installed in or on recreational vehicles and or boats.
- Use an oven mitt or glove when opening the grid lid.
- Children should not be left alone or unattended in an area where the appliance is being used. DO NOT allow children to sit, stand or play on or around the appliance at any time.
- Never let clothing, potholders or other flammable materials come in contact with or too close to any grate, burner or hot surface until it has cooled. The fabric could ignite, causing serious personal injury.
- Only certain types of glass, ceramic earthenware and other glazed utensils are suitable for grill use. Other types of material may shatter with sudden temperature changes. Use only low or medium heat settings in accordance with the manufacture's guidelines.
- Do not heat unopened food containers as a built-up of pressure may cause the containers to burst.
- Use an oven mitt when opening the grid lid.
- Never lean over an open grill.

When lighting a burner, always pay close attention to what you are doing. Make certain you are aware of which burner you are lighting so that your body and clothing remain clear of open flames.



### **WARNING! WHEN USING THE GRILL**

- **DO NOT** touch the grill rack, burner grate or immediate surroundings as these areas become extremely hot and could cause burns. Use only dry potholders. Moist or damp potholders on hot surfaces may cause steam burns.
- **DO NOT** use towel or bulky cloth in place of potholders.
- Grease is flammable, let hot grease cool before attempting to handle it. DO NOT allow grease deposit collect in the grease tray. CLEAN THE GREASE TRAY OFTEN.
- **DO NOT** use aluminum foil to line the grills rack or grill bottom.

For proper lighting and performance of the burners, keep the burner clean. It is necessary to clean them periodically for optimum performance. The burners will only operate in one position and must be mounted correctly for safe operation.

Exercise caution when cleaning the grill. To avoid steam burns, DO NOT use a wet sponge or cloth to clean the grill while it is hot. Some cleaners produce noxious fumes or can ignite if applied to a hot surface.

## **NEVER USE A DENTED OR RUSTY PROPANE GAS CYLINDER**

**DO NOT** use the grill to cook excessively fatty meats or other products which promote flare-ups.

**DO NOT** operate the grill under unprotected combustible constructions.

USE only well ventilated areas. **DO NOT** use in buildings, garages, sheds or other such enclosed areas.

This grill is designed for optimum performance without the use of briquettes.

**DO NOT** place briquettes on the flame tamers as this will block the vent to the grill burners.

Adding briquettes can damage ignition components.

Never use the grill in extremely windy conditions. If located in a consistently windy area, a wind-break will be required.

# Assembling the Drop-in BBQ 4000DG-DL-SS/BLK

Tools required:

- Phillips Head Screwdriver
- Gloves

## 1. Flame Diffuser Assembly

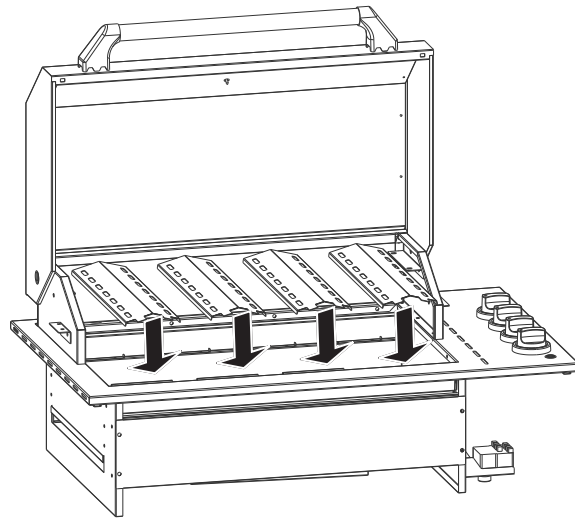

## 2. Cooking grid / cooking plate assembly

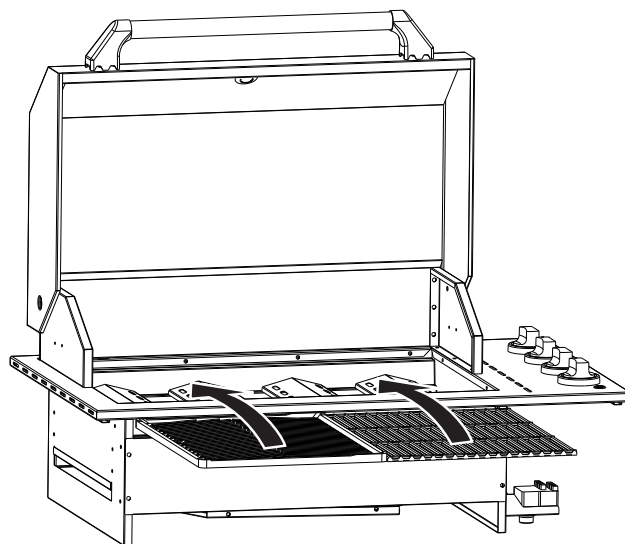

3. Warming rack assembly

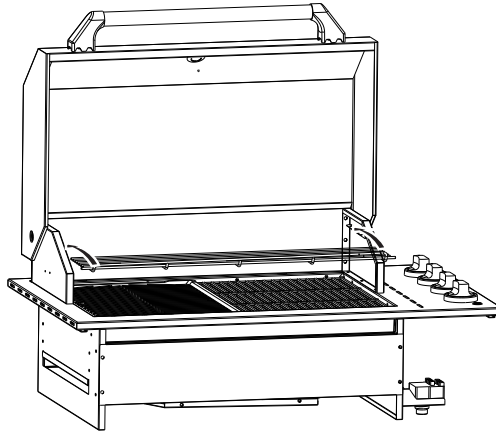

4. 1 x AA Battery (not included)

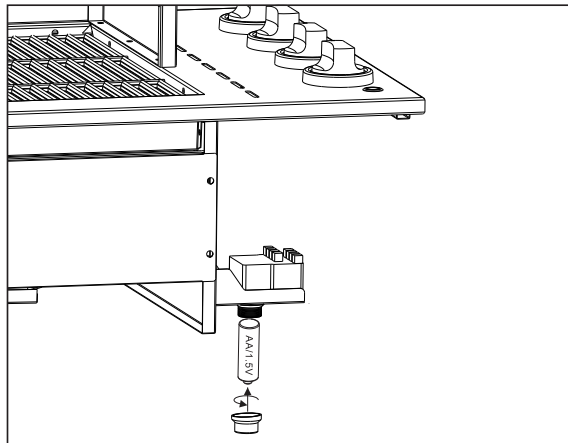

5. Oil Tray Assembly

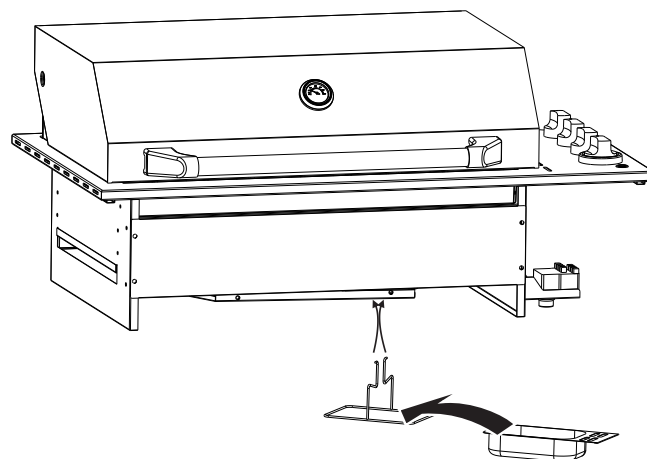

7. Transformer and cable connection

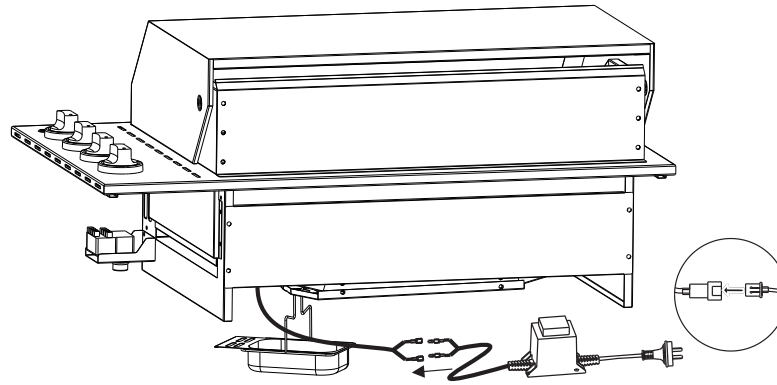

**WARNING**

**THE TRANSFORMER NEEDS TO BE INSTALLED AND PLACED FAR AWAY FROM THE APPLIANCE**

# Assembling the Drop-in Side Burner – SMA-DSG30010-SS/BLK

1. Cooking Grid Assembly

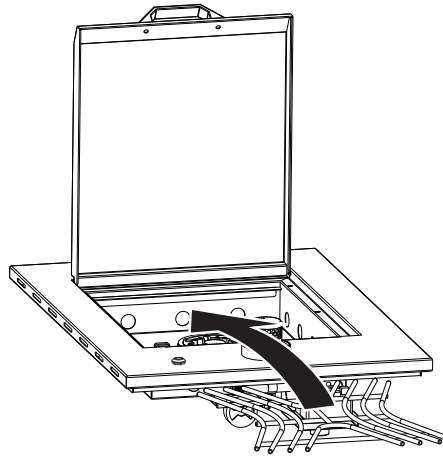

2. 1 x AA Battery (not included)

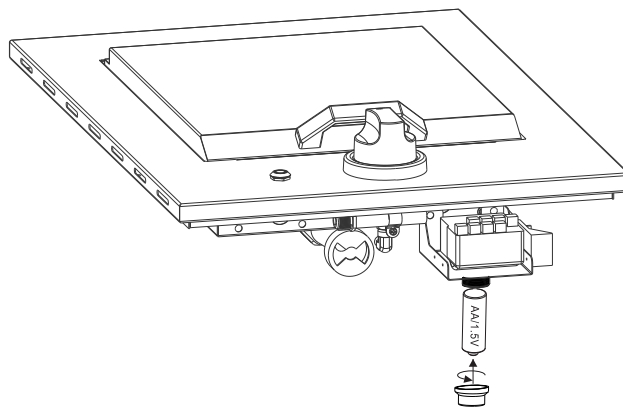

# Gas Connection

## WHEN INSTALLED OUTDOORS ONLY



### WARNING

THE UNIT'S VENTILATION OPENINGS MUST NOT BE COVERED DURING INSTALLATION.

## REFER TO AS/NZS 5601 (GAS INSTALLATIONS) & FOLLOWING PAGE FOR FURTHER DETAILS

Connect the appliance to the cylinder or system according to the requirements of current law, making sure that the appliance is configured for the type of gas available. If not, see: "Adapting to different types of gas". Also check that the feed pressure falls within the values shown in the table: "Gas specifications".

## RIGID AND SEMI-RIGID METAL & RUBBER HOSE CONNECTIONS MUST BE APPROVED TO AS/NZS 1869 FOR HOSE ASSEMBLIES AND AS 4631 FOR SEMI-RIGID CONNECTORS FOR GAS.

Make the hook-up with metal fittings and pipes (even flexible hoses) so as not to stress the components inside the appliance. A rubber hose connection complies with current law only if the hose can be inspected along its entire length and easily replaced near the expiration indicated on the hose.

**Note:** After installation, use soapy water to check the perfect seal of the entire connection system

## DO NOT USE AN OPEN FLAME TO CHECK THE GAS SEAL.

- For connection to 9Kg portable gas cylinders
- For connection to a fixed LPG Supply: It is possible to connect this barbecue to a fixed LPG reticulated piping system which may supply gas to other appliances in the building. The installation must be carried out by a licenced gas fitter in accordance with AS/NZS 5601 and any relative Building Code/Statutory Regulations. The gas fitter must check the appliance data label to confirm the gas type prior to installation, ensure that the barbecue is operating correctly and show the customer how to operate the barbecue on completion of installation.
- For connection to a fixed natural gas supply: It is possible to connect this barbecue to a fixed natural gas piping reticulated system. The installation must be carried out by a licenced gas fitter in accordance with this instruction manual, AS/NZS 5601 and any relative Building Codes/Statutory Regulations. The gas fitter must check the appliance data label to confirm the gas type prior to installation, ensure that the barbecue is operating correctly and show the customer how to operate the barbecue on completion of the installation.

## **IMPORTANT NOTES RELATING TO FIXED INSTALLATION BARBECUES**

- For barbecues designed for built in fixed installation: please ensure that the clearances are observed and adhered to
- For barbecue designed for built in fixed installation
  1. Before each use remove any accumulated grease and other cooking residue
  2. Check the hose & regulators, if they appear to be damaged in any way, have a licenced gas fitter replace them.

## **IMPORTANT NOTES RELATING TO CONNECTION VIA PORTABLE LPG CYLINDER**

- For barbecues connected via 9Kg portable LPG cylinder: Should the cylinder be housed in a closed compartment under the barbecue, minimum free ventilation at high and low level of 20,000mm squared is required as per AS/NZS 5601 Appendix J Clause J3.4 (d)
- For barbecues connected via 9Kg portable LPG cylinder: The barbecue is supplied with a hose and regulator already attached to the barbecue manifold.
  1. Attach the regulator end of the hose assembly to the LPG cylinder.
  2. Ensure that the valves on the barbecue are in the off position.
  3. Turn the cylinder valve on and apply a soapy water solution to all the joints to ensure there are no gas leaks. If bubbles form at any of the joints this indicates a gas leak and the cylinder valve should be turned off and the joints tightened.
  4. If the gas leak persists, turn the cylinder valve off and contact an authorised installer/dealer for assistance.
  5. Never look for gas leaks with a naked flame
  6. Check the hose & regulator assembly on a regular basis and if found to be damaged, have it replaced. It is recommended that these components be replaced every five years.
  7. Inspect the gas cylinder routinely to ensure the test date is not overdue. Cylinder should be re-tested and certified every 10 years.
  8. Before each use remove any accumulated grease & any other cooking residue

## WHEN INSTALLED INDOORS ONLY

### GAS CONNECTION

Connect the appliance to the piping system according to the requirements of current law, making sure that the appliance is configured for the type of gas available. If not, see: "Adapting to different types of gas". Also check that the feed pressure falls within the values shown in the table: "Gas specifications".

### CONNECTION USING HOSE ASSEMBLIES OR SEMI-RIGID CONNECTORS FOR GAS

If installing this appliance with a semi rigid hose assembly connector for gas, the hose assembly must be certified to AS/NZS 1869 Class B or D with a length of no more than 1.2 metres. The semi-rigid connector must be certified to AS 4631. (Ref AS/NZS5601.1 (refer to Clause 6.6.1)

**Note:** After installation, use soapy water to check the perfect seal of the entire connection system.  
**DO NOT USE AN OPEN FLAME TO CHECK THE GAS SEAL.**

Refer to AS/NZS 5601.1 for (6.3) GAS APPLIANCE LOCATION, (6.4) AIR SUPPLY TO GAS APPLIANCES & (6.10.1.7) Barbecues in residential premises; minimum vertical clearance to an overhead grease filter or overhead combustible surface is 1200mm

Maximum height of the top of the grill with respect to the surface that supports the appliance is 10mm.

# Natural Gas Conversion



## **WARNING**

**CONVERSIONS ONLY TO BE DONE BY AUTHORISED PERSON**

Tools required:

- Socket headset screwdriver (included with BBQ)
- Wrench

## **GAS PIPING**

- A minimum pipe with diameter 15mm is required for inlet piping. A lever operated shut-off valve should be installed with 1 meter of the appliance for serving the appliance.
- Where its not practical to install solid tube certified to AS/NZS 1869 Class B or D, stainless steel braided hose could be installed. This hose assembly must comply with AS/ANZ 5601 Gas installations, pipe sizing tables and shall not exceed 3 meters in length. The internal diameter of the hose must not be less than 10mm.
- All the gas pipe connection must be sealed with a gas pipe compound resistant to natural gas

## **INSTRUCTIONS FOR CONVERTING THE MAIN BURNERS**

# Instructions for converting the main burners

1. Unscrew the main burner and thermocouple's cover, loose the thermocouple to left side

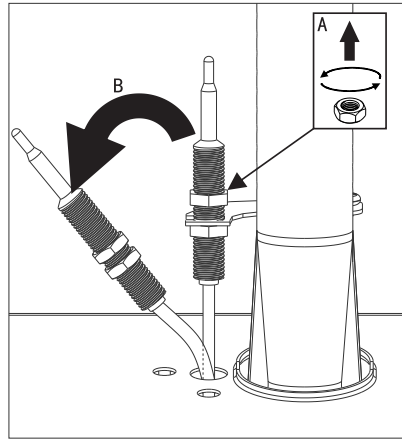
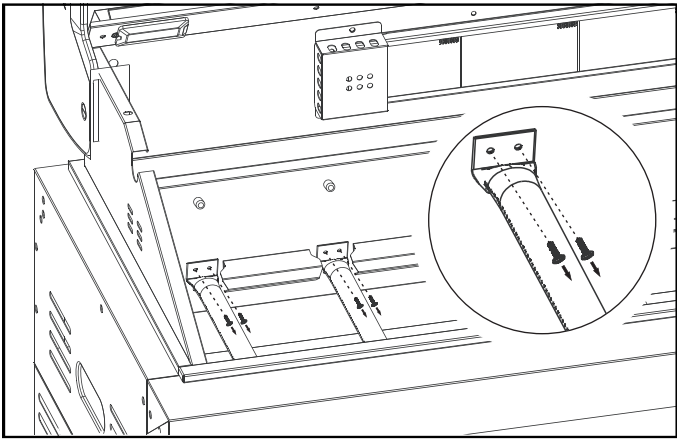

2. Remove the main burner.

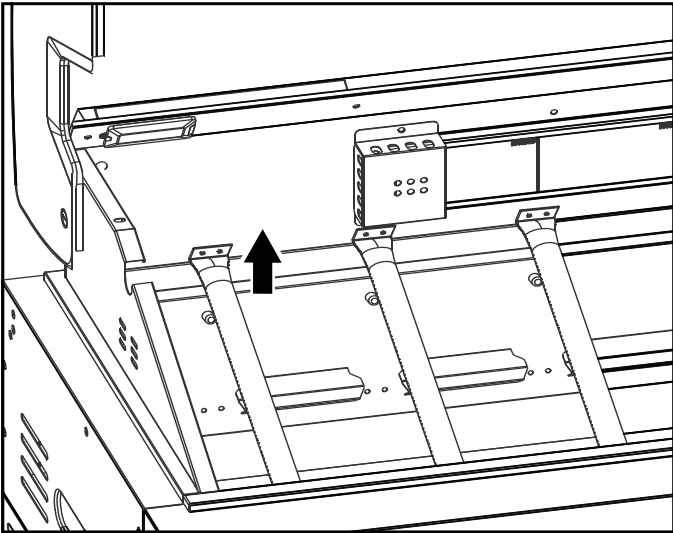

3. With the burner removed, you will see the brass gas jet which is screwed into the end of the valve. Using the socket driver supplied, unscrew the end LPG jet while retaining the inner (NG) jet

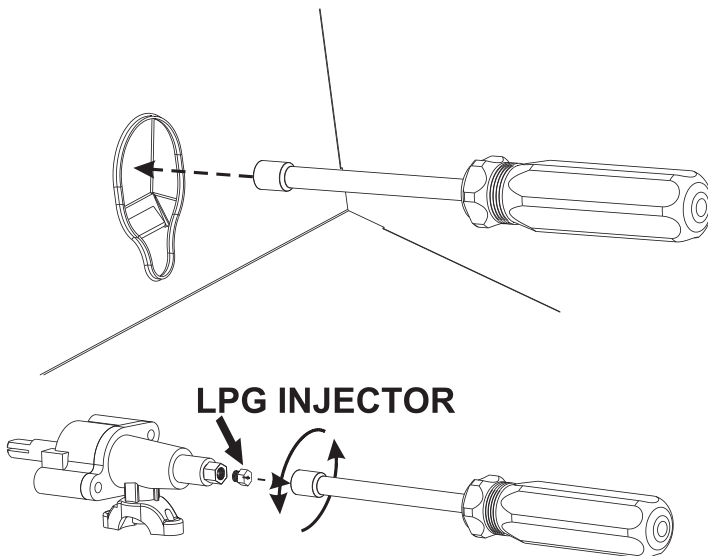

4. Re-assembly the burners

# Gas Cylinder Safety Information

## OUTDOOR

- When converted for the use of universal LPG, the appliance is designed to use different types of cylinders depending on the installation made.
- The gas cylinder must be manufactured and marked in accordance with the specifications for LPG cylinders.
- The shut-off valve must be closed when the appliance is not in use.
- The gas cylinders must be kept in an approved housing out of the reach of children.
- When you disconnect the gas cylinder, make sure all the control valves are in the "OFF" (O) position.
- Before disconnecting, remove the cylinder from any housing in which it may be located.
- When you reconnect the hose to the cylinder, make sure all the connections are tight before placing it back in its compartment.
- After each connection of a cylinder, perform a leak test as described below.

## LEAK TESTING PROCEDURE

- Make sure that all the gas taps and cylinder valve are in the "OFF" position
- Mix a solution of water and detergent or soap in a small container.
- After connecting the hose, open the valve on the gas cylinder or gas system tap.
- Using a brush, paint the solution on the gas connection points and check for bubbles.
- Bubbles indicate a leak.
- Close the valve and tighten the fitting, possibly inserting a new gasket. Repeat the leak test.
- If the leak persists, turn off the gas and contact an authorized gas system maintenance technician to repair the leak.

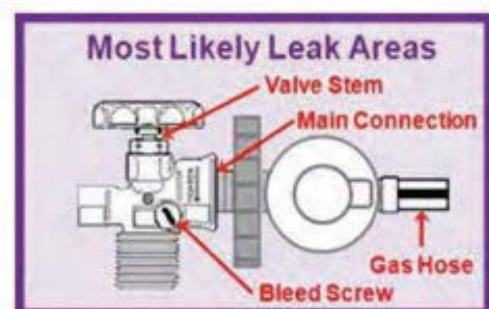
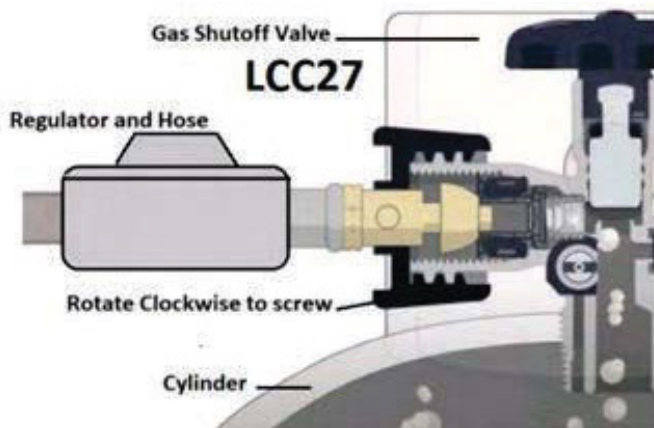

**DO NOT USE OR STORE FLAMMABLE MATERIALS ON OR NEAR THIS APPLIANCE**  
**DO NOT PLACE ARTICLES ON OR AGAINST THIS APPLIANCE**  
**DO NOT MODIFY THIS APPLIANCE**  
**DO NOT USE AN ADAPTOR AT THE CYLINDER CONNECTION**

# Installation Procedure



## WARNING!

- PLEASE FOLLOW FOLLOWING INSTRUCTIONS TO INSTALL
- DO NOT BLOCK ANY VENTILATION OF THE BBQ.
- THE ENCLOSURE MATERIAL FOR THE CUTOUT IS NOT COMBUSTIBLES
- DO NOT PLACE GAS CYLINDER DIRECTLY UNDERNEATH THE BARBECUE. KEEP REQUIRED CLEARANCE
- ENSURE FLOOR CLEARANCE ARE KEPT AND CAVITY UNDERNEATH THE BARBECUE
- PLEASE FOLLOW THE INSTRUCTIONS FOR INSTALLATION AND USAGE IN THIS USER MANUAL CAREFULLY

## INSTALLING THE BUILT-IN BBQ 4000DG-DL-SS

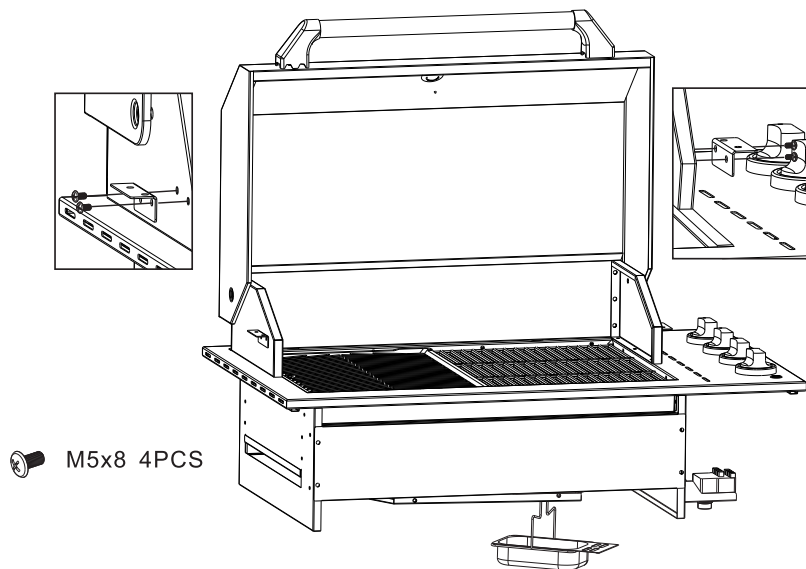

## DIMENSIONS

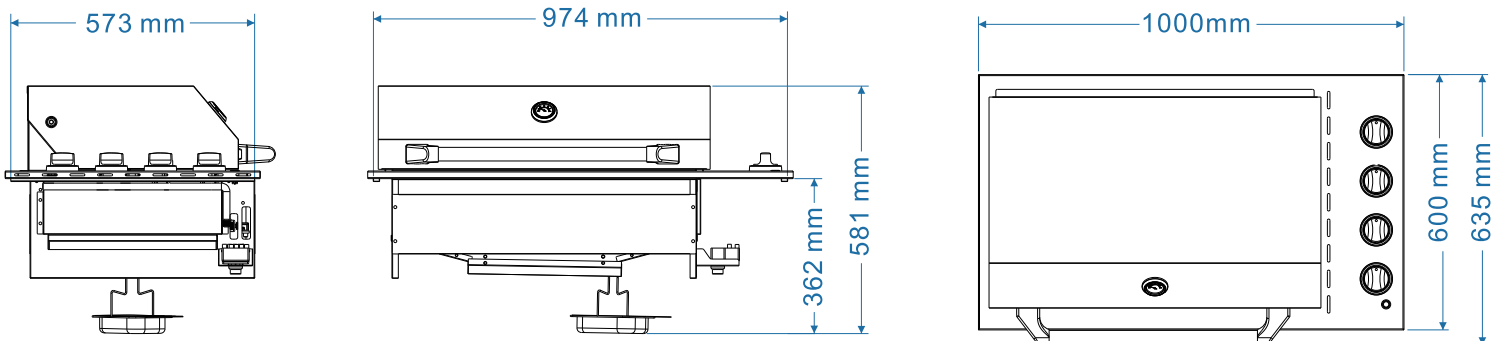

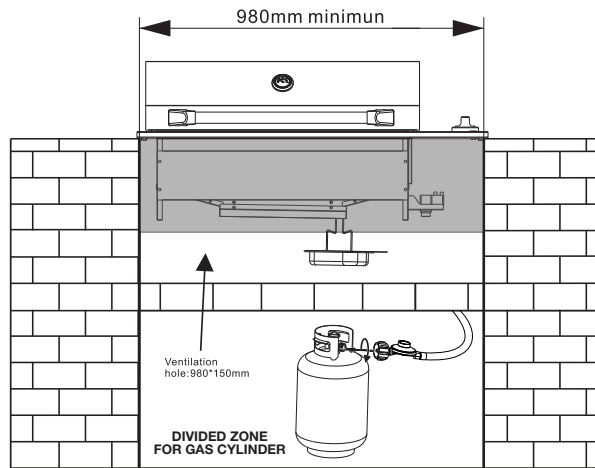
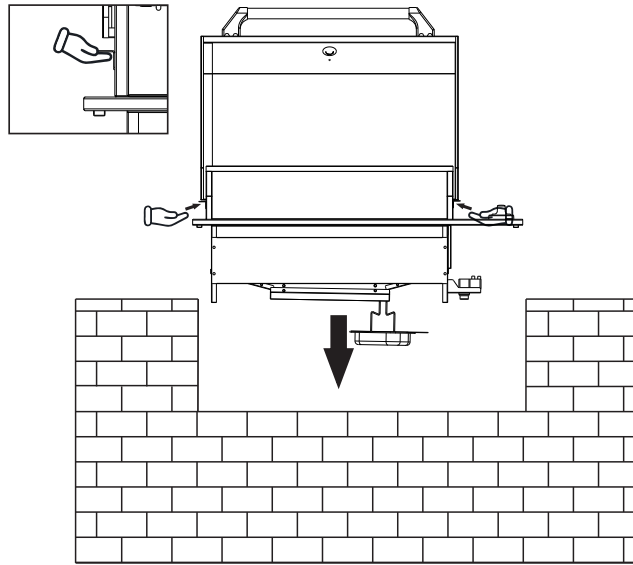

\*Please note oil tray is removed from front of BBQ so please allow access to remove and clean

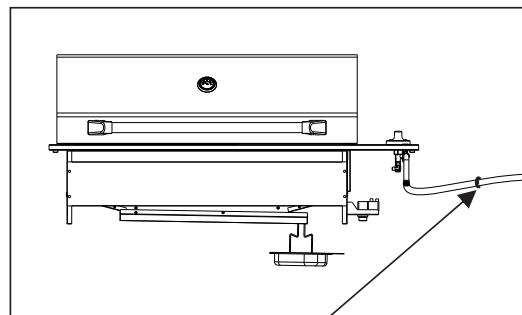
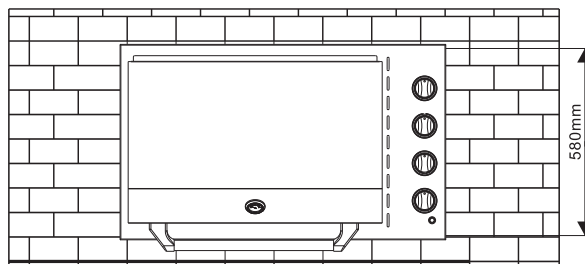

When the mobile barbecue is connected to a fixed gas supply via flexible hose connection, a retaining tether of adequate strength shall be fixed to the appliance and be suitable to be fixed to the wall within 50mm of each connection point, the retaining tether must be less than 80% of the gas hose length.

**Option 1: The side burner is used independently (The regulator and gas hose is not included)**

## INSTALLING THE DROP-IN SIDE BURNER SMA-DSG0010-SS/BLK

### DIMENSIONS

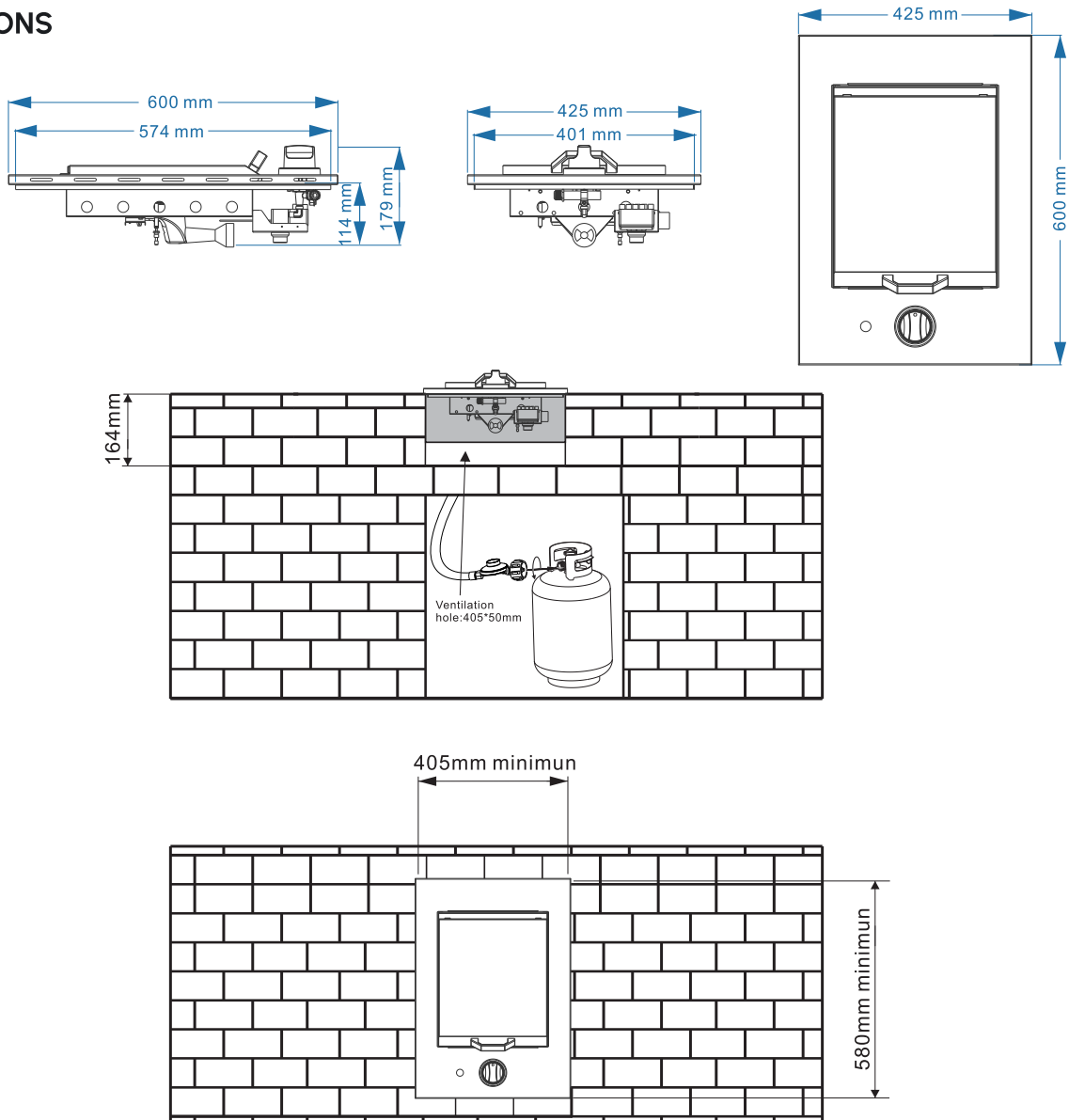

**Option 2: The side burner can be connected to the gas grill**

1. Unpack the regulator hose from the hose pipe.
2. Regulator hose connect with the connector together.
3. Finally, connect with hose pipe of grill and side burner, which can be used together.

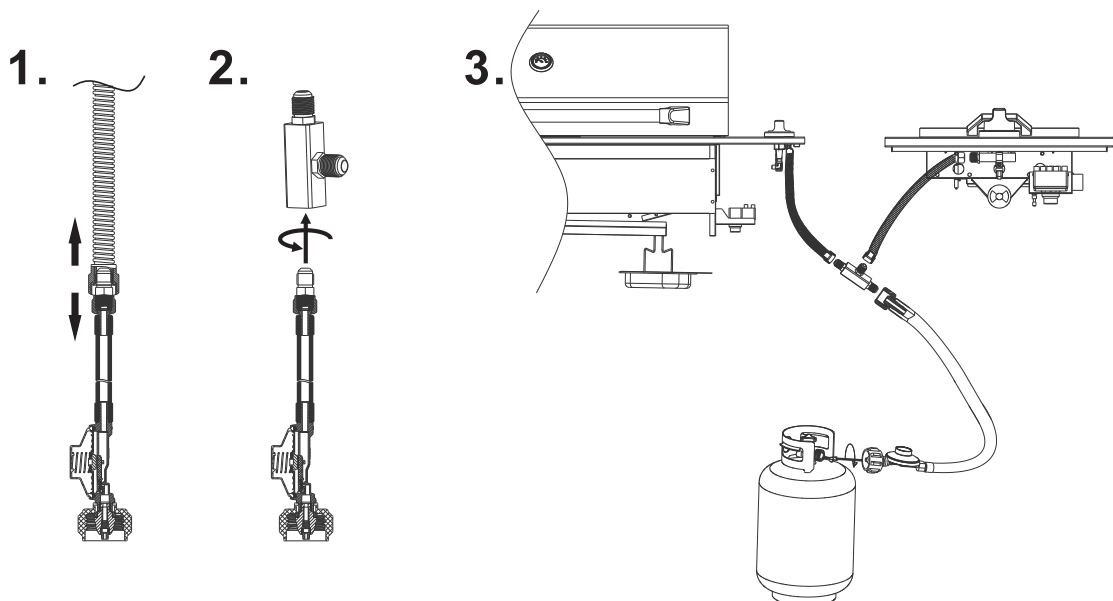

# Electrical Components



## **WARNING!**

**ELECTRICAL GROUNDINGS INSTRUCTIONS FOR TRANSFORMER - THIS APPLIANCE (TRANSFORMER) IS EQUIPPED WITH A PLUG AND SHOULD BE PLUGGED DIRECTLY INTO A PROPERLY GROUNDED RECEPTACLE. WHEN INSTALLED, MUST BE ELECTRICALLY GROUNDED IN ACCORDANCE WITH LOCAL CODES.**

- 1. TO PROTECT AGAINST ELECTRICAL SHOCK, DO NOT IMMERSE CORD OR PLUGS IN WATER OR OTHER LIQUIDS. THE ENCLOSURE MATERIAL FOR THE CUTOUT IS NOT COMBUSTIBLES**
- 2. UNPLUG FROM THE OUTLET WHEN NOT IN USE AND BEFORE CLEANING. ALLOW TO COOL BEFORE PUTTING ON OR TAKING OFF PARTS.**
- 3. DO NOT OPERATE ANY OUTDOOR COOKING GAS APPLIANCE WITH A DAMAGED CORD, PLUG, OR AFTER THE APPLIANCE MALFUNCTIONS OR HAS BEEN DAMAGED IN ANY MANNER.**
- 4. DO NOT LET THE CORD HANG OVER THE EDGE OF A TABLE OR TOUCH ANY HOT SURFACE.**
- 5. DO NOT USE AN OUTDOOR COOKING GAS APPLIANCE FOR PURPOSE OTHER THAN INTENDED.**
- 6. WHEN CONNECTING, FIRST CONNECT PLUG TO THE OUTDOOR COOKING GAS APPLIANCE THEN PLUG APPLIANCE INTO THE OUTLET.**
- 7. USE ONLY A GROUND FAULT INTERRUPT (GFI) PROTECTED CIRCUIT WITH THIS APPLIANCE.**

# Indoor Installation Instructions & Warnings



## WARNING!

- IF THE BARBECUE IS EXPOSED TO THE WEATHER, WE RECOMMEND THE PVC COVER IS USED, THIS IS INCLUDED WITH PURCHASE OF BBQ.
- SCAN THE QR CODE FOR RECOMMENDED RANGE HOODS.

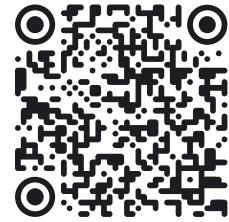

## SELECTION OF THE POINT OF INSTALLATION

- The appliance must only be installed on non-combustible materials. The minimum distance from combustible materials is 1500mm overhead, 250mm sides and 200mm rear. (Indoor installation only)
- The appliance must be installed in accordance with standards and local deviations.
- Ventilation must be ensured on both LPG & NG. Gas is highly explosive and can cause serious personal injury and property damage if it is left to accumulate and then ignited. personal injury and property damage if it is left to accumulate and then ignited.
- The barbecue is designed to be mounted in a counter with a minimum depth of 700mm.
- Avoid locations exposed to the wind as this may affect cooking and the efficiency of the burners. If you cannot avoid such a location, screens may be necessary.

## INSTALLATION COMPARTMENT

- The barbecue requires a non-combustible barrier beneath it to prevent reaching excessive temperatures. The panel that acts as a barrier must be positioned 30/35 mm below the base of the unit.
- The installation compartment must be made of non-combustible materials. Materials suitable for its construction include brick, granite, marble, Hardiplank® and Villaboard® on a metal or brick structure.
- The appliance requires ventilation openings in the front wall of the compartment.
- The appliance unit can be mounted in an island counter or a counter with splash guard. Read the specific requirements for each type of mounting.
- When mounting the appliance against a wall, it is essential to insulate combustible materials. All combustible materials must be kept at least 1500mm overhead, 250mm sides and 200mm rear away from the barbecue.
- The minimum depth of the mounting surface (counter) is 700mm
- The required dimensions of the cut-out vary from model to model, please see dimension drawings for more information.

## ISLAND-MOUNTED

- If the appliance is installed in an island, it can be placed in the center. Pay particular attention to the overall dimensions of the top of the island, considering the open lid and its projection.
- The required dimensions of the cut-out vary from model to model, please see dimension drawings for more information.

**NB:** Use of engineered stone (e.g. Cesar stone) as a bench top is permitted providing temperatures up to 120°C are tolerated

## AS/NZS 5601 CLAUSE 6.10.1.7 BARBECUES IN RESIDENTIAL PREMISES

Barbecues in residential premises shall be installed such that—

- a. measured horizontally, a vertical combustible surface less than 200 mm from the cooking surface area is protected in accordance with Clause 6.10.1.2 for a height of 150 mm; and
- b. the clearances shown in Table 6.8 are observed.

### NOTES:

1. This Clause (6.10.1.7) applies to gas appliances designed for use without a cooking vessel where cooking fats can fall on to and flare up from a heated perforated plate, volcanic rock or similar refractory material.
2. Any combustible surfaces less than 1200 mm but not less than 600 mm from the cooking surface may be protected in accordance with Clause 6.10.1.2. The 'cooking surface area' is defined as that part of the gas appliance where cooking normally takes place and does not include those parts of the gas appliance containing control knobs.

This appliance must be installed by an authorised person in accordance with this instruction manual, AS/NZS 5601 – Gas installations (installation and pipe sizing), local gas fitting regulations, local electrical regulations, local water regulations, local health regulations, Building Code of Australia and any other government authority.

This appliance is suitable for connection with rigid pipe or flexible hose. The isolating manual shut-off valve connection point must be accessible when the appliance is installed. Flexible hose assembly must be certified to AS/NZS 1869 class B or D, be of appropriate internal diameter for the total gas consumption, be kept as short as possible (not exceeding 1200mm), must not be in contact with the floor or any hot or sharp surfaces. The hose assembly must not be subject to strain, abrasion, kinking or deformation.

**Natural Gas:** the supplied regulator must be fitted to the appliance inlet connection. Gas pressure must be adjusted to 1.0 kPa when approximately 50% of the burners are on high flame, the appliance test point is located on the regulator.

**ULPG:** the supplied test point adaptor must be fitted to the appliance inlet connection. Gas pressure must be adjusted to 2.75 kPa, the appliance test point is located on the test point adaptor.

Gas leakage and operation of the appliance must be tested by the installer before leaving. Check burner flames are blue in colour, stable and completely ignite at both high and low flame settings with no appreciable yellow tipping, carbon deposition, lifting, floating, lighting back or objectionable odour. Test burners individually and in combination, When satisfied with the operation of the cooker, please instruct the user on the correct method of operation.

Overhead clearances— (Measurement A) Range hoods and exhaust fans shall be installed in accordance with the manufacturer's relevant instructions. However, in no case shall the clearance between the highest part of the barbecue and a range hood be less than 1200 mm, for an overhead exhaust fan, 1200mm.

Side clearances— (Measurements B, & C) Where B, measured from the edge of appliance to any vertical combustible surface, or vertical combustible surface covered with toughened glass or sheet metal, is less than 200 mm, the surface shall be protected to a height C of not less than 150 mm above the hob for the full dimension (width or depth) of the cooking surface area.

**NB:** Use of engineered stone (e.g. Cesar stone) as a bench top is permitted providing temperatures up to 120°C are tolerated

# Outdoor Installation Instructions & Warnings

This appliance shall only be used in above ground open-air situations with natural ventilation, without stagnant areas, where gas leakage and products of combustion are rapidly dispersed by wind and natural convection.

Any outdoor enclosure in which the appliance is used shall comply with one of the following:

- An enclosure with walls on all sides, but at least one permanent opening at ground level and no overhead cover. See Figure 1.
- Within a partial enclosure that includes an overhead cover and no more than two walls. See Figure 2.
- Within a partial enclosure that includes an overhead cover and no more than two walls, the following shall apply:
  - At least 25% of the total wall area is completely open; and
  - At least 30% of the remaining wall area is open and unrestricted. See Figure 4 & 5.
- In the case of balconies, at least 20% of the total of the side, back and front wall areas shall be and remain open and unrestricted.

The following diagrams provide a diagrammatic representation of outdoor areas. Rectangular areas have been in these figures – the same principles apply to any other shaped area.

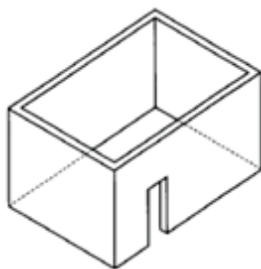

Figure 1 - Enclosure with walls on all sides but

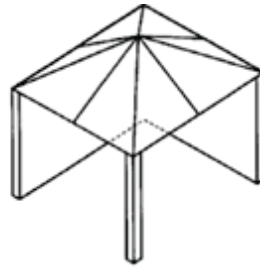
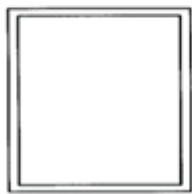

Figure 2 - Partial Enclosure with overhead cover and no more than 2 walls

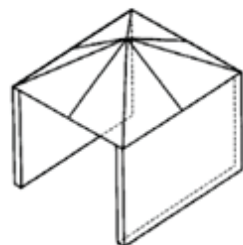
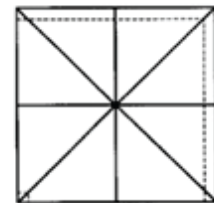

Figure 3 - Partial Enclosure with overhead cover and no more than 2 walls

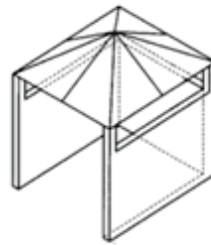
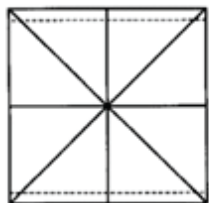

Figure 4 - Open side at least 25% of total wall area  
30% or more in total of the remaining wall area is open and unrestricted.

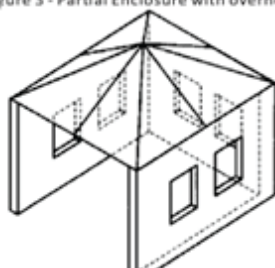
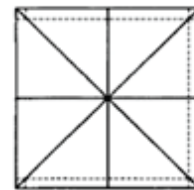
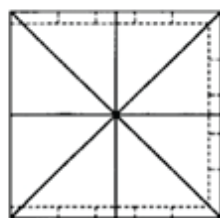

Figure 5 - Open side at least 25% of total wall area.  
30 percent or more in total of the remaining wall area is open and unrestricted



## SECTION OF THE POINT OF INSTALLATION

- The appliance must not be installed on combustible materials. \*The minimum distance from combustible materials is 1500 mm overhead, 300 mm sides and 200 mm rear.
- The free space above the cooking surface with respect to combustible materials must be at least 1500 mm.
- The appliance must be installed in accordance with standards and local deviations.
- When using LPG, ventilation must be ensured in the compartment. The gas is highly explosive and can cause serious personal injury and property damage if it is left to accumulate and then ignited.
- Avoid locations exposed to the wind as this may affect cooking and the efficiency of the burners. If you cannot avoid such a location, screens may be necessary.

## INSTALLATION COMPARTMENT

- The installation compartment must be made of non-combustible materials. Materials suitable for its construction include brick, granite, marble, Hardiplank® and Villaboard®.
- The appliance requires ventilation openings in the front wall of the compartment.
- The appliance unit can be mounted in an island counter or a counter with splash guard. Read the specific requirements for each type of mounting.

## ISLAND-MOUNTED

- If the appliance is installed in an island, it can be placed in the centre. Pay particular attention to the overall dimensions of the top of the island, considering the open lid and its projection.

## INSTALLATION IN A COUNTER IN A SPECIAL CONTEXT

- The context must be made of non-combustible material.
- When mounting the appliance against a wall or a fence, it is essential to insulate combustible materials. All combustible materials must be kept at least 1500mm overhead, 250mm side & 200mm rear away from the barbecue.
- Models with high cooking cover require a specific free space on the back of the barbecue between the splash guard and the cut-out of the counter of at least 70 mm. This, so that the hood has the free space needed to open.

**NB:** Use of engineered stone (e.g. Cesar stone) as a bench top is permitted providing temperatures upto 120°C are tolerated

# Alfresco Checklist

Currently for residential premises, barbecues are certified under a domestic appliance standard and classified as outdoor appliances. Once they are moved to an 'enclosed' alfresco area, they must be a compliant appliance under AS/NZS 5263.1.1.

1.	<b>Does the Alfresco area have sufficient natural ventilation?</b> See information below this checklist for natural ventilation requirements.	<input type="checkbox"/> Yes	<input type="checkbox"/> No	If Yes, an outdoor domestic BBQ may be used. <b>If no, all below additional requirements must be satisfied.</b>
<b>If you answered 'No' to item 1, the Alfresco is considered to be Enclosed. And the following requirements must be satisfied.</b>				
2.	Appliance installation to be compliant for mechanical ventilation. <b>Requires rangehood / extraction fan*</b>	<input type="checkbox"/> Complete		
3.	Installation requires approved interlock mechanism that confirms the rangehood is extracting before allowing gas to flow to the BBQ.	<input type="checkbox"/> Complete (Optional)		

\*See over page for additional information

\* Note: This system is suitable for Natural gas and plumbed LPG systems. This system is not suitable for Portable Gas Bottles.

## NATURAL VENTILATION REQUIREMENTS

### When is an Alfresco considered 'outdoors'?

A covered Alfresco area is considered outdoors when it is an open-air situation with natural ventilation.

- If the Alfresco meets the below minimum requirements, it is considered that natural ventilation is provided and an outdoor domestic BBQ may be used.
- If the Alfresco does not meet the below minimum requirements, it is considered an enclosed Alfresco and additional requirements must be satisfied.
- For additional information, see Energy Safety publication - "Safe locations for barbecues and gas patio heaters".

#### Compliant examples:

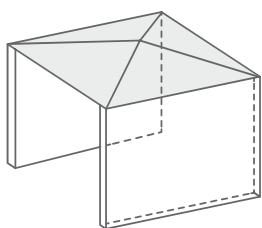

Not more than:

- Two parallel wall with a covered roof

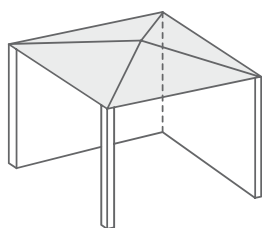

Not more than:

- Two walls at right angles with a covered roof.

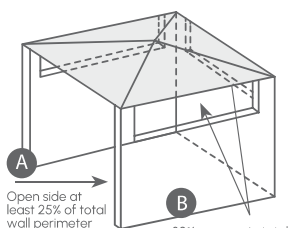

Not more than:

- Three walls, with the one open side being at least 25% of the total perimeter (A)
- The remaining three walls having an area of 30% or more of unrestricted opening (B)

#### Non-compliant examples:

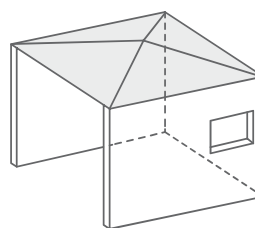

- Remaining 3 walls do not have 30% or more of unrestricted opening

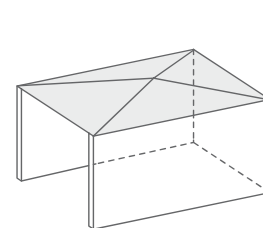

- Open side is less than 25% of the total perimeter

**Note:** The above applies to a fully detached alfresco and/or and alfresco sharing a house wall

## ADDITIONAL INFORMATION

### EXTRACTION FAN:

- A commercial style range hood/extraction canopy must be fitted above the appliance to provide adequate ventilation as Standard AS/NZS 5601 dictates
- The extraction fan filter must not be closer than 1200mm to the cooking surface
- The fan must move at least 2000m<sup>3</sup> of air per hour. ATCO recommends the use of a 2 motor fan to achieve this flow rate
- Not only will the fan remove any harmful products of combustion, but it will also stop grease and smoke from damaging the alfresco walls and ceiling

### INTERLOCK TO BE INSTALLED:

- For added protection an interlock can be installed:

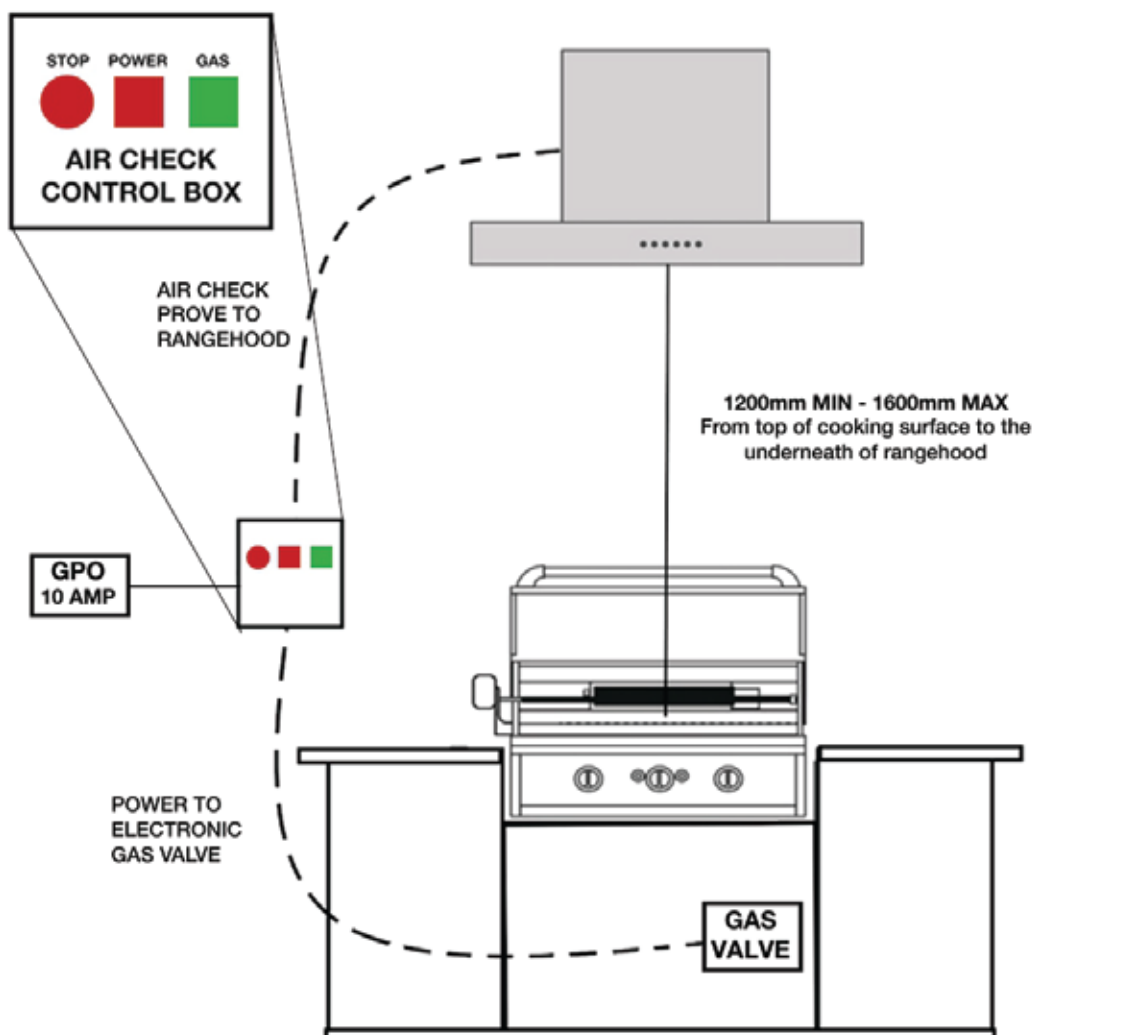

\*Centralise the rangehood to the BBQ once lid is open

Note: The above applies to a fully detached alfresco and/or alfresco sharing a house wall

# Igniting the BBQ

This barbecue is designed for use outdoors, away from any flammable materials.

It is important that the ventilation openings of the cylinder compartment are not obstructed.

No modifications should be made to any part of this barbecue and repairs and maintenance should be carried out by an authorized person

**DO NOT** let children operate or play near grill.

**DO NOT** use charcoal or ceramic briquettes in a gas grill.

**DO NOT** light or use the side burner with the lid in the closed position.

**DO NOT** attempt to light burner with lid closed. A buildup of non-ignited gas inside a closed grill is hazardous.



## **WARNING!**

**THE SIDE BURNER IS DESIGNED FOR POT/PAN WITH DIAMETER 60-260MM**

**SIDE BURNER LID CAN NOT BE USED AS A WORK TABLE**

**DO NOT PUT ANYTHING ON THE SIDE BURNER LID WHILE IT IS NOT WORKING**

## **TO LIGHT THE GRILL**

1. Open the lid and make sure all the knobs are on the OFF position.
2. Push down and turn the control knob anticlockwise to HIGH(+), if the burner ignites, keep pressing the control knob for 10 seconds until the flame stable.
3. Adjust the heat by turning the knob to the High/Low position.
4. To light the other burners, repeat the same process for the adjacent burner and continue in sequence until all the burners are lit.
5. To turn the barbecue OFF, turn the cylinder valve or regulator switch to the OFF position and then turn all of the control knobs on the barbecue clockwise to the OFF position.

## **FOR MATCH LIGHTING**

1. For Main burner, place the match into match holder chain and fire the match, then put the match into the lighting hole on the right side of the fire box;
2. For side burner, place the fired match on the holes of the side burner head.
3. Push down and turn the knob anticlockwise to HIGH position, then the burner can be lit. If the burner does not light, turn off the gas tap and wait for 5 minutes then repeat.

Before cooking for the first time, light on all the main burners and keep burning for 15 minutes with the lid closed and knob at HIGH position. This will "heat clean" the internal parts and dissipate odor from the painted finish. The color of cooking area may get a little change. It is normal and it is the nature of material.



**WARNING!**

**WHILE IGNITING MAIN BURNER AND INFRARED REAR BURNER, MAKE SURE THE LID IS IN OPEN SITUATION. DO NOT IGNITE WITH SIDE BURNER LID CLOSED. DO NOT CLOSE SIDE BURNER LID WHEN SIDE BURNER IS IN OPERATION.**

**WHILE COOKING WITH THE HOOD CLOSED AND WITH ALL THE BURNERS ON, MAKE SURE ALL THESE BURNERS ARE IN LOW FLAME POSITION.**

# Cleaning & Care

Regular cleaning is required for the longevity of your BBQ, failed to do so and this can affect your warranty.

## STAINLESS STEEL

There are many stainless steel cleaners available. Always use the mildest cleaning process first, scrubbing in the direction of the grain. DO NOT use steel wool as it will scratch the surface. To touch up noticable scratches in the stainless steel, sand very lightly with dry 100 grit sand paper in the direction of the grain. Grease specks can gather and bake onto the surface of the stainless steel, giving the appearance of rust. For removal, use an abrasive pad with stainless steel cleaner.

## COOKING GRATES

- The easiest way to clean the grill is shortly after cooking is completed, the flames have been turned off and the plates have started to cook.
- Wear a barbecue mitt to protect your hand from heat and steam.
- Scrub the hot cooking grates by dipping a bristled barbecue brush in tap water. Cleaning will be more difficult if the grill is cold.
- Please note these plates are dishwasher safe

## OIL TRAY

- The oil tray should be emptied, wiped down and washed after each use with a mild detergent and warm water solution. Check the grease pan frequently and do not allow excess grease to accumulate and flow out of the grease pan.
- Please note these plates are dishwasher safe.

## GRILL BURNER

- Extreme care should be taken when removing a burner. It must be correctly centered on the orifice before any attempt is made to relight the grill. Frequency of cleaning depends on how often you use the grill.
- Failure to properly place the burner over the orifice could cause a fire to occur behind and beneath the valve panel, thereby damaging the grill and making it unsafe to operate.
- Before cleaning, make sure the gas supply and control knobs are in the 'OFF' position and the burners have cooled.

## GRILL BURNER

- Extreme care should be taken when removing a burner. It must be correctly centered on the orifice before any attempt is made to relight the grill. Frequency of cleaning depends on how often you use the grill.
- Failure to properly place the burner over the orifice could cause a fire to occur behind and beneath the valve panel, thereby damaging the grill and making it unsafe to operate.
- Before cleaning, make sure the gas supply and control knobs are in the 'OFF' position and the burners have cooled.

## FOLLOW THESE INSTRUCTIONS TO CLEAN PARTS OF BURNER ASSEMBLY OR IF YOU HAVE TROUBLE IGNITING THE GRILL

1. Turn gas off at control at control knobs and LPG tank
2. Remove cooking grates, grease tray and grease cup
3. Remove screw at the end of the burner using a screwdriver
4. Carefully lift each burner up and away from valve openings
5. Wire brush entire outer surface of burner to remove food residue and dirt
6. Clean any blocked ports with a stiff wire such as an open paper clip
7. Check burner for damage, due to normal wear and some corrosion

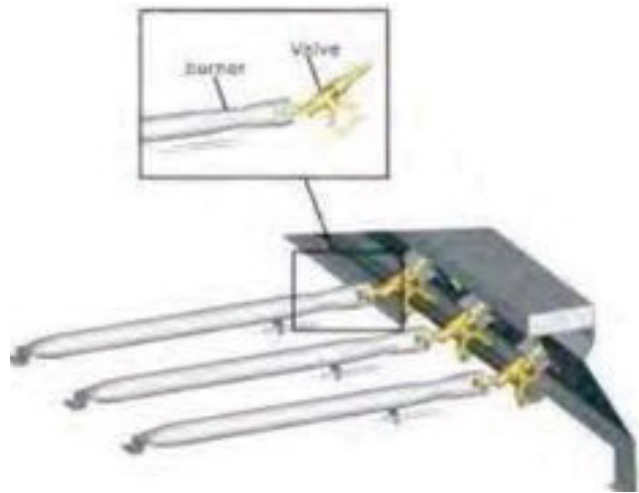

## WE SUGGEST FOLLOWING WAYS TO CLEAN THE BURNER TUBES

1. Bend a stiff wire (a light weight coat hanger works well) into a small hook. Run the hook through each burner tube and burner several times.
2. Use a narrow bottle brush with a flexible handle (DO NOT use a brass wire brush), run the brush through each burner tube and burner several times.
3. Wear eye protection: use an air hose to force air into the burner tube and out of the air ports. Check each port to make sure air comes out each hole.





**WARNING!**

**NATURAL HAZARD SPIDERS**

**FACT: SOMETIMES SPIDERS AND OTHER INSECTS CLIMB INTO THE GRILL TUBES TO THE BURNERS. THE SPIDERS SPIN WEBS, BUILD NESTS, AND LAY EGGS. THE WEBS OR NESTS CAN BE VERY SMALL, BUT THEY ARE VERY STRONG AND CAN BLOCK THE FLOW OF GAS.**

**CLEAN BURNERS PRIOR TO USE AFTER STORING, AT THE BEGINNING OF GRILLING SEASON, OR AFTER A PERIOD OF ONE MONTH NOT BEING USED.**

**SPIDER GUARDS ARE ON THE AIR INTAKES IN AN EFFORT TO REDUCE THIS PROBLEM, BUT IT WILL NOT ELIMINATE IT! AN OBSTRUCTION CAN RESULT IN A "FLASHBACK" (A FIRE IN THE BURNER TUBES). THE GRILL MAY STILL LIGHT, BUT THE OBSTRUCTION DOES NOT ALLOW FULL GAS FLOW TO THE BURNERS.**

# Maintenance

## REPLACING BBQ LIGHTS



### WARNING!

- THE LIGHT ARE HOT WHEN IN OPERATION, PLEASE REPLACE ONCE OFF AND COOLED DOWN
- ALWAYS KEEP THE LIGHT IN DRY CONDITION

1. Unscrew the light

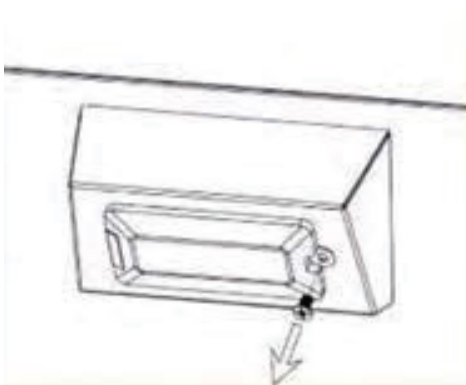

2. Take out the light

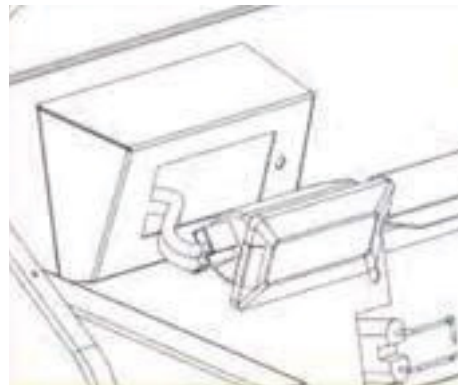

3. Unscrew the cable

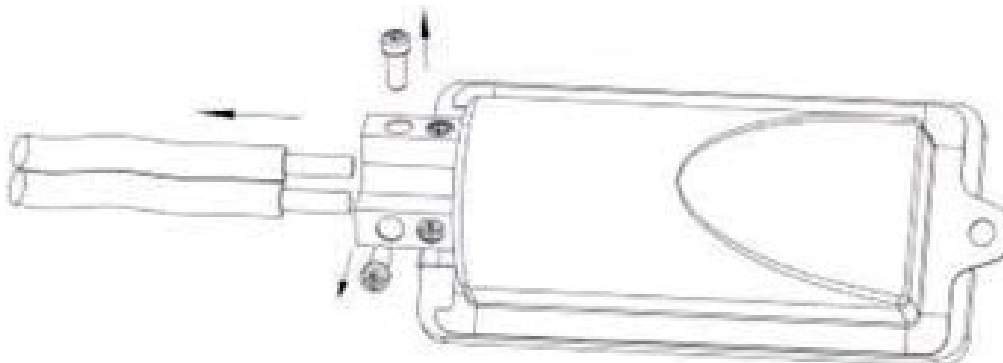

## Replacing BBQ Lights

- The LED light is inserted into the control bezel as a whole unit, if it needs to be replaced, the whole unit needs to be replaced

1. Take off the control knob

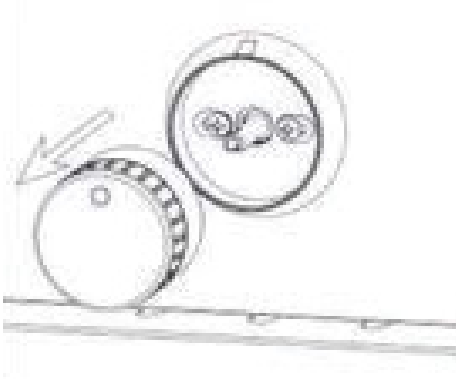

2. Unscrew the knob bezel

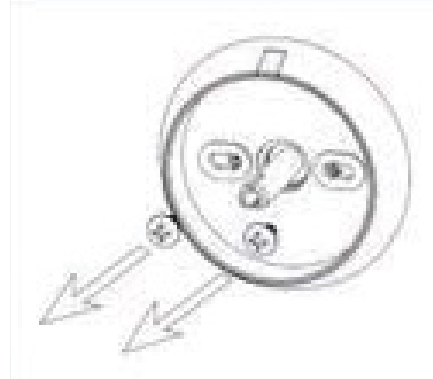

3. Take off the unit and loose the LED cable as a whole unit, if it needs to be replaced, the whole unit needs to be replaced

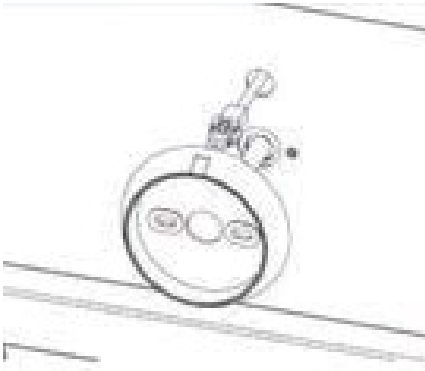

# Troubleshooting

PROBLEM	POSSIBLE CAUSE	SOLUTION
The barbecue doesn't light	No gas	Check that the shut-off valve is open (ON) Gas cylinder empty - refill or change the cylinder
	The ignition system is not working	Check the battery - you should hear a clicking sound when you press the knob Replace the battery
		Light the barbecue manually
	Gas tap regulated too high	Clean and delicately dry the electrode making sure that its position is correct
Excessive smoke from the cooking surface	Gas valve set too high	Lower the gas or turn off some of the burners
Odour of gas DO NOT TRY TO LIGHT THE APPLIANCE	Gas leak	Close the gas with the shut-off valves
		Check for leaks, tighten the fittings
		If the problem persists, call the Service Centre

# Warranty Registration

## WARRANTY

### TERMS & CONDITIONS

Terms and conditions apply only to Sirius products distributed in Australia and New Zealand by Arisit Pty Limited.

This warranty applies for a period of 3 years on stainless steel for manufacturing defects. Not including, but not limited to rust, corrosion or damage cause due to the elements, or cleaning products.

This warranty applies for a period of 36 months on other components.

Warranty applies for parts and labour in Australia or New Zealand, commencing from date of purchase. Our goods come with guarantees that cannot be excluded under the Australian Consumer.

For any other reasonably foreseeable loss or damage. You are also entitled to have the goods repaired or replaced if the goods fail to be of acceptable quality and the failure does not amount to a major failure.

Should any part fail due to defective workmanship or faulty materials within the specified period from the date of purchase. Arisit Pty Limited will repair or replace the defective part free of charge.

#### LP/Propane Gas Cylinder

The cylinder manufacturer is responsible for the materials workmanship and performance of the gas cylinder. Contact your dealer or the cylinder manufacturer in respect of all warranty claims or service.

#### Warranty Administration

Evidence of the date of purchase must be provided to obtain benefit under this warranty.

This warranty only applies to the original purchaser/hire purchaser of this appliance and cannot be assigned or transferred. Failure to produce documentary proof of the date of original acquisition by the original purchaser will result in a charge being levied for work done, labour and parts supplied.

We reserve the right to amend any of the terms and conditions without prior notice.

#### Conditions of Warranty

1. The appliance is delivered to Arisit Pty Limited service department or authorised service agent and freight charges both ways are paid by the owner. No liability is accepted for loss or damage during transit.
2. The appliance is installed by a qualified person and operated and maintained in accordance with the instructions supplied. Repairs or service must be carried out by an authorised person.
3. Installation must conform to the applicable Gas, Electrical and Building standards laid down by the local codes for your region.
4. No alterations or repairs have been carried out without obtaining the distributors prior consent. Such repair or any replacement does not extend the warranty period.
5. Loss of use of the appliance or consequential loss of any nature is not covered.
6. This warranty does not affect your statutory rights.

#### Not Covered

Exposure of the barbeque appliance to the elements should be minimised. Once the unit has cooled and cleaned, store the barbeque under cover. Polyester/Vinyl barbeque covers are an optional accessory that will ensure years of trouble free operation.

This warranty does not cover the purchaser or any other person for damage, malfunction or loss due to the following:

Lack of maintenance abuse neglect misuse accident or improper installation of this appliance.

Scratches, dents, discolouration or corrosion due to heat, abrasive or chemical cleaners, or chipping on porcelain parts.

Corrosion rust or damage caused by exposure to the elements grease fires insects, weather or hail.

Note: Barbecues must be covered when not in use.

Cleaning and normal wear and tear. Service calls of this nature are chargeable. Rusting of cast iron plates, grills and burners. The appliance has been used/installed anywhere other than a private dwelling, or where it has been used other than domestic use.

Unauthorised repairs during the warranty period, Removal or re-installation costs.

Cracks and weathering of timber parts caused by exposure to the elements or damage by weather heat, insects, chemicals or foods acids or juices

Losses caused by act of God, failure to obtain spare parts strikes or lockouts are not covered.

# Purchase Registration

To register your purchase, please complete the section and return it to:

**ARISIT PTY LTD 40-50 MARK ANTHONY DRIVE, DANDENONG SOUTH, VIC 3175**

Title

Initials

Surname

Address

Postcode

Contact Number

Purchase date

Appliance type

Model Number

Retailer Name





