

OWNER'S MANUAL

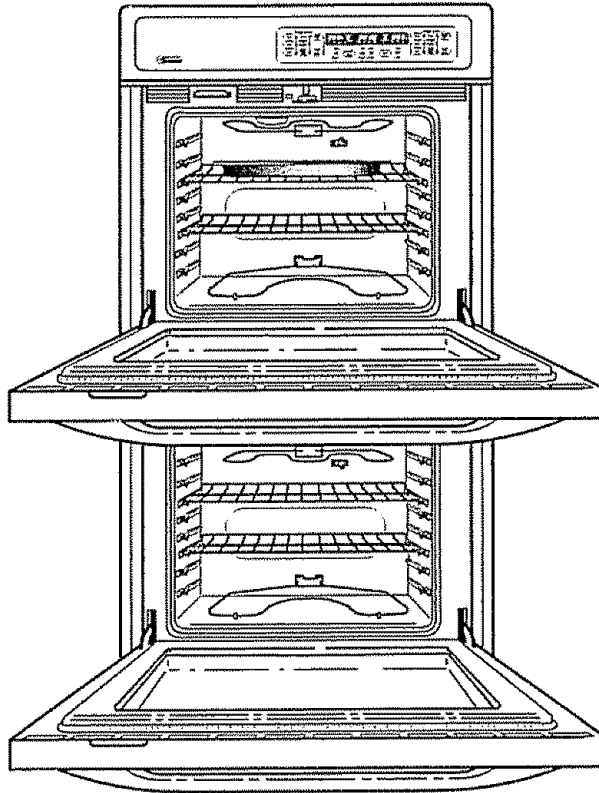

DOUBLE 30" ELECTRIC SELF-CLEANING BUILT-IN WALL OVEN

MODEL NO.
911. 41185
911. 41189



CAUTION:

Before using this oven,
read this manual and
follow all its Safety Rules
and Operating
Instructions.

- Safety Instructions
- Operation
- Care and Cleaning
- Problem Solving

Sears, Roebuck and Co., Hoffman Estates, IL 60179 U.S.A.

229C4020**P191-1** (SR-10401)



30" SELF-CLEANING DOUBLE OVEN

TABLE OF CONTENTS

SAFETY INSTRUCTIONS

Oven Safety3-4

OPERATION

Features of Your Oven 5
 Removal of Packaging Tape 5
 Oven Control, Clock, Timer 6
 Control Display 7
 Clock 8
 Kitchen Timer 8
 Tones 9
 F Code 9
 Oven Cooking Tips 10, 11
 Baking 12
 Broiling 13
 Setting Special Features .. 14, 15

CARE AND CLEANING

Self-Cleaning Cycle:..... 16, 17
 Control Panel 18
 Broiler Pan and Grid 18
 Oven Interior 18
 Oven Light Bulb 18
 Oven Racks 19
 Oven Door 19

PROBLEM SOLVING

Before Calling for
 Service 20, 21
 Temperature Adjustment 22
 Warranty 23
 Consumer Service Numbers ... 24

For your convenience and future reference, please write down your model and serial numbers in the space provided. They are located on the front frame behind the oven door.

MODEL NUMBER:

SERIAL NUMBER:





IMPORTANT SAFETY INSTRUCTIONS

SAVE THESE INSTRUCTIONS

Read all instructions before using this appliance. When using gas or electrical appliances, basic safety precautions should be followed, including the following:



To insure safety for yourself, family and home, please read your Owner's Manual carefully. Keep it handy for reference. Pay close attention to Safety Sections. **BE SURE** your appliance is installed and grounded by a qualified technician.

- **DO NOT** leave children alone or unattended near an appliance in use.
- **TEACH CHILDREN** not to play with controls or any part of the appliance, and not to sit, climb or stand on the door, or any part of the appliance.
- **CAUTION: NEVER STORE** items of interest to children in cabinets above the appliance. Children climbing on an appliance could be seriously injured.
- **KEEP THIS** book for later use.
- **NEVER TRY** to repair or replace any part of the appliance unless instructions are given in this manual. All other work should be done by a qualified technician.
- **NEVER USE** your appliance for warming or heating the room.
- **ALWAYS KEEP** combustible wall coverings, curtains, dishcloths, towels, potholders, and other linens a safe distance from the appliance.
- **NEVER USE** a towel or other bulky cloth as a potholder and make sure the potholder is dry. Moist potholders could cause steam burns. **DO NOT** let potholders touch hot surfaces.
- **ALWAYS KEEP** the oven area free from things that will burn. Food, wooden utensils, grease buildup, gasoline and other flammable vapors or liquids could catch fire. Plastic utensils could melt, and canned foods could explode. Your appliance should never be used as a storage area.
- **ALWAYS KEEP** your appliance clear of things that will burn (gasoline and other flammable vapors or liquids).
- **NEVER HEAT** unopened food containers. Pressure buildup can cause the container to burst and cause injury.
- **NEVER LEAVE** jars or cans of fat or drippings in your oven.
- **NEVER TRY** to clean a hot surface. Some cleaners produce noxious fumes, and wet cloths or sponges could cause steam burns.
- **NEVER WEAR** loose fitting clothing when using your appliance.
- **BE SURE** the oven is securely installed in a cabinet that is firmly attached to the house structure.



IMPORTANT SAFETY INSTRUCTIONS

- **DO NOT** touch heating elements, surfaces near them, or interior oven surfaces. These may be hot enough to cause burns even though they are dark in color. During and after use, do not touch or let clothing or flammable material contact the elements or hot surfaces until they have had time to cool. Other surfaces near the oven vent openings, oven door, and window may also be hot enough to cause burns

OVEN SAFETY

- **PLACE OVEN RACKS** in the desired position while the oven is cool. If racks must be moved while oven is hot, do not let potholder contact the hot oven element.
- **AFTER BROILING**, always take the broiler pan and grid out of the oven and clean them. Leftover grease in the broiler pan could catch fire the next time you use your oven.
- **ALWAYS USE** care when opening the oven door. Let hot air and steam escape before moving foods.
- **NEVER USE** aluminum foil to line the oven bottom. Improper use of foil could start a fire, or electrical shock could result.
- **NEVER BLOCK** the oven vent opening.

SELF-CLEAN SAFETY

- **CLEAN ONLY** the parts listed in this manual. Follow all cleaning instructions.
- **NEVER RUB**, move or damage the door gasket on self-cleaning ranges.
- **NEVER TRY** to clean utensils, cookware, removable parts or broiler pan and grid in the self-clean cycle

- **DO NOT USE** oven cleaners – No commercial oven cleaner or protective coating of any kind, should be used in or around any part of the oven.

IMPORTANT SAFETY NOTICE!

The California Safe Drinking Water and Toxic Enforcement Act requires the governor of California to publish a list of substances known to the state to cause birth defects or other reproductive harm and requires businesses to warn their customers of potential exposure to such substances. The fiberglass insulation in a self-cleaning oven will give off a very small amount of carbon monoxide during the cleaning cycle. Exposure can be minimized by venting with an open door or window or using a ventilation fan or hood.

IMPORTANT: The health of some birds is extremely sensitive to the fumes given off during the self-cleaning cycle of any range. Move birds to another well-ventilated room.

READ AND UNDERSTAND THIS INFORMATION NOW!

Be sure everyone in your home knows what to do in case of fire. Never use water on a grease fire; it will only spread the flames.

OVEN FIRE:

Do not try to move the pan!

1. Close the oven door and turn controls off.
2. If fire continues carefully open the door, throw baking soda on the fire, or use a dry chemical, foam, or halon type extinguisher.



OPERATION

FEATURES OF YOUR OVEN

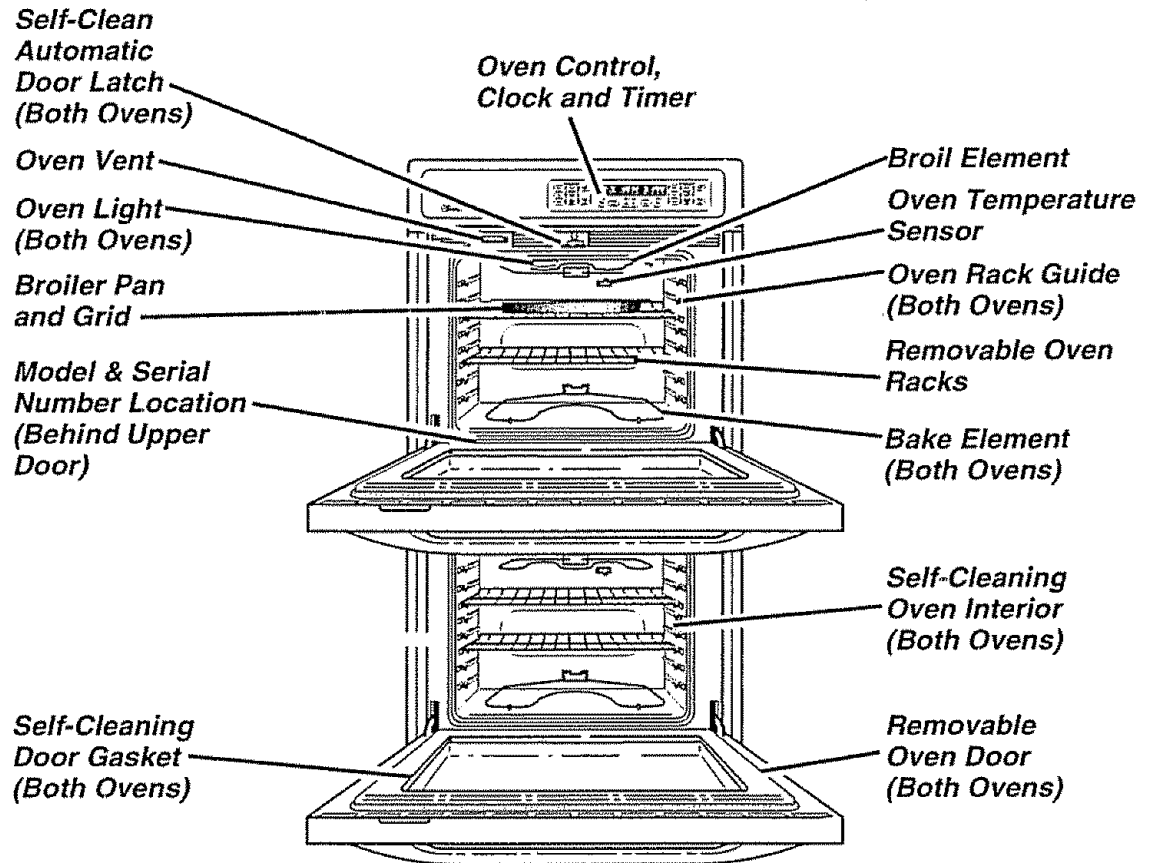

REMOVAL OF PACKAGING TAPE

To remove the adhesive left from packaging tape, use household dishwashing liquid, mineral oil or cooking oil. With a soft cloth rub into the area and allow to soak. Rinse and dry well. Repeat procedure using an appliance polish to insure no damage is done. **This should be done before the oven is turned on for the first time. The tape cannot be removed once the oven has heated.** Packaging tape may be found in the following areas: door handle, control panel area, door trim and oven area.



OPERATION

Oven Control, Clock and Timer

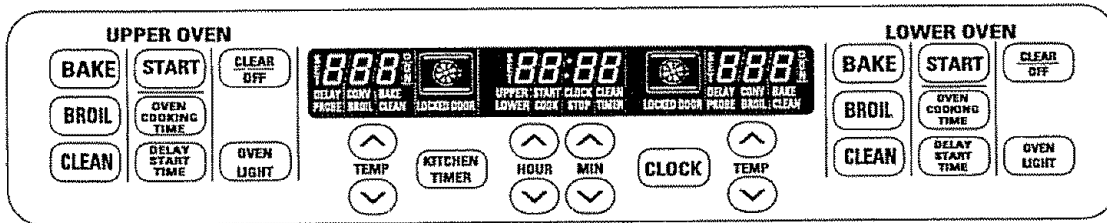

Your new touch pad oven control will allow you to set oven functions with ease. Below are the different types of functions and a description of each.

TRADITIONAL OVEN FUNCTIONS

BAKE — Cooks foods in the traditional oven with a temperature range of 170°F to 550°F.

BROIL — Cooks foods at 550°F **HI** broil or 450° **LO** broil from the direct heat of the upper element. Broiling should be done with the door opened to the broil stop position.

CLEAN — Cleans the inside area of the oven for you. When the cycle is finished, the oven will turn off automatically.

TIMED OVEN FUNCTIONS



Set the amount of time you want foods to cook or the oven to clean. The oven turns off automatically at the end of this time.



Set the time of day you want the oven to turn on. The oven will turn on automatically at the time you have set.

OTHER TOUCH PADS

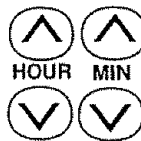

The **HOUR/MIN UP** and/or **DOWN** arrow pads set the time of day, length of cooking time, length of cleaning time, the delayed start time, and the time set on the Kitchen Timer.



The **TEMP UP** and/or **DOWN** arrow pads set the temperature used for cooking.



The **START** pad must be pressed to activate any oven function.



The **CLEAR/OFF** pad is used to cancel any oven function and the end of cycle tone. **It will not cancel the Clock or Kitchen Timer.**



The **KITCHEN TIMER** pad is used to turn the Kitchen Timer on or off. It will not control any of the other oven functions.



The **CLOCK** pad is used to set the time of day.



Turns oven light on or off.





OPERATION Control Display

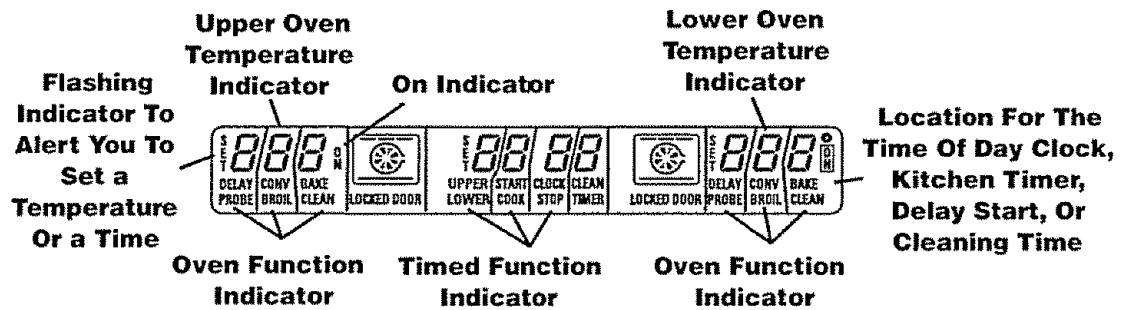

The Control Display is an easy reference for using your oven control. Below are descriptions of how the Control Display works.

OVEN TEMPERATURE INDICATOR

— This indicator has a multiple purpose.

- **Displays the temperature**
- **Displays an error code** —
“ERR” - If the oven temperature indicator flashes “ERR”, then you have set an invalid time or temperature.
- **Displays Oven Problems** — If your control flashes “F” and a number or letter, you have experienced an oven problem. Please read the section on **F-CODES** in your manual.

“ON” INDICATOR — Will light when the oven turns on.

SET INDICATORS — The set indicator will flash in combination with an oven function or timed function to let you know you need to set a time or temperature. Example: “**SET**” and “**BAKE**” will **Flash** to let you know you need to set the bake temperature.

TIMED INDICATOR — Displays the time of day, cooking time, delay start time, cleaning time or the time set on the kitchen timer.

- **Displays a reminder code** —
“**PUSH START**”—If the time indicator flashes the words “**PUSH START**”, then you need to press the **START** pad to activate your setting.

OVEN FUNCTION INDICATORS

— Displays which oven function has been set, when the oven door locks, and if the function is delayed.



OPERATION

Clock and Timer

CLOCK

The clock must be set for the correct time of day before a delayed oven function can work properly. The time of day **cannot** be changed during a timed oven function, but **can be** changed during a bake or broil function.

HOW TO SET THE CLOCK

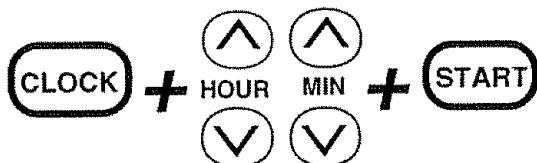

1. Press the **CLOCK** pad.
2. Press the **HOUR/MIN UP** and/or **DOWN** arrow pads to set the time.
3. Press the **START** pad.

RECALL THE CLOCK

While using your oven for cooking, press the **CLOCK** pad if you wish to check the time of day. The current time of day will show in the display.

POWER FAILURE

If you have experienced a power failure, the time will flash in the display and will be incorrect. Reset your clock.

Any oven cooking function that was in process will need to be reset.

KITCHEN TIMER

The Kitchen Timer is used to time cooking processes or other household activities. It does not control the oven. It can be set for up to 9 hours and 59 minutes. It will count down in minutes until the **LAST 60 SECONDS** is reached, then the control will beep once. When the countdown reaches **ZERO**, the control will beep 3 times followed by one beep every 6 seconds until the **KITCHEN TIMER** pad is pressed. The 6 second beep can be removed for future cycles if desired. For directions on removing this continuous beep, see Tones on the following page.

HOW TO SET THE TIMER

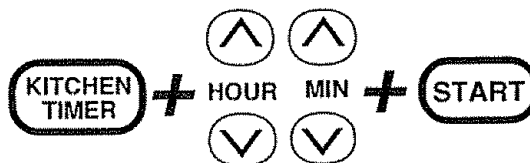

1. Press the **KITCHEN TIMER** pad.
2. Press **HOUR/MIN UP** and/or **DOWN** arrow pads to set time.
3. Press the **START** pad.
4. When the countdown has reached zero, press the **KITCHEN TIMER** pad to turn off the beep.

To cancel the timer during the countdown, press the **KITCHEN TIMER** pad **TWICE**



OPERATION

Oven Control, Clock and Timer

TONES

Your new control has a series of tones that will sound at different times. These tones may sound while you set the control for an oven function, or at the end of the oven function. It will also alert you that there may be a problem with the functions. Below are the types of tones and a brief description of each.

TONES WHILE SETTING THE CONTROL — When you press a touch pad you will hear a beep. This beep will let you know you have placed enough pressure on the pad to activate it. (The arrow pads do not beep.)

END OF TIMED CYCLE TONE — At the end of a timed cooking function, you will hear 3 short beeps followed by 1 beep every 6 seconds. This 6 second beep will continue to sound until the **CLEAR/OFF** pad is pressed or you may select the special feature to cancel this 6 second beep from sounding at the end of future cycles.

TO CANCEL THE 6 SECOND BEEP

1. Press and hold the **BAKE** and **BROIL** pads, **at the same time** for 3 seconds, until the display shows **"SF"**.
2. Press the **KITCHEN TIMER** pad. The display will show **"CON BEEP"** (continuous beep).
3. Press the **KITCHEN TIMER** pad again. The display will show **"BEEP"** (beep canceled).
4. Press the **START** pad to cancel the 6 second beep and leave the special feature mode.

If you would like to return the 6 second beep, repeat steps above until the display shows your choice and press the **START** pad

ATTENTION TONE — This tone will sound if you make an error or an oversight is made while setting an oven function.

Examples would be:

- a. Setting a clean cycle and the oven door is not properly closed.
- b. Setting function and not pressing the **START** pad.
- c. Pressing an additional function pad without first setting a temperature or time.

Any of these can be quickly identified by watching the display.

PREHEAT TONE — When you set an oven temperature, the oven automatically starts to heat. When the temperature inside the oven reaches the temperature you have set, a tone will sound to let you know the oven is ready for baking.

F CODE

If you set an oven function and the control beeps while the display is flashing **"F"** and a number or letter such as **"F-4"** or **"FI"** there may be a problem with the control or oven. Simply press the **CLEAR/OFF** pad and wait about an hour. Try setting the function again. If the code repeats, write down the flashing code and call for service. Tell the technician what code was flashing.



OPERATION

Oven Cooking Tips

STRONG SMELL OR ODOR

It is normal to have some odor when using your oven for the first time. To help eliminate this odor, **ventilate the room by opening a window or using a vent hood.**

ALUMINUM FOIL

IMPORTANT: Never cover the oven bottom or oven rack with aluminum foil. Improper use can cause poor heat flow, poor baking results, and may damage the oven finish. To prevent staining from spillovers, you may place a piece of aluminum foil or a cookie sheet below foods which may spill over.

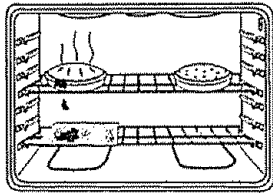

OVEN VENT

The oven vent is located under the control panel. This area could become hot during oven use. The vent is important for proper air circulation. **Never block this vent.**



NO PEEKING

Opening the door often to check foods will cause heat loss and poor baking results.

PREHEATING

Preheating is bringing the oven temperature up to the temperature you will be using during baking.

OVEN TEMPERATURE SENSOR

In the back of the oven you will notice a small tube. This is a heat sensor that maintains the temperature of the oven. Never move or bend this tube.

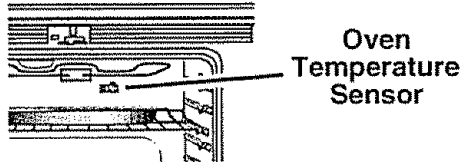

LOW TEMPERATURE ZONE

The low temperature zone of your oven (between 170° and 200°F) is available to keep hot cooked foods warm. However, foods should not be kept at these temperatures longer than 2 hours.

USING DELAY STARTS

When using your convenient Delay Start operation, foods such as dairy products, fish, poultry, etc., should never sit more than 1 hour before cooking. Room temperatures and the heat from the oven light promote bacterial growth.

THE TYPE OF MARGARINE AFFECTS BAKING PERFORMANCE

Most recipes for baking have been developed using high-fat products such as butter or margarine (80% fat by weight—the federal requirement for products labeled "margarine"). You will get poor results if cakes, pies, pastries, cookies or candies are made with low-fat spreads. Low-fat spreads contain less fat and more water. The high moisture content of these

continued on next page





OPERATION

Oven Cooking Tips

Margarine (cont.)

spreads affects the texture and flavor of favorite baked recipes. The lower the fat content of a spread product, the more noticeable these differences become. To ensure best results, use margarine, butter or stick spreads containing at least 70% vegetable oil.

ELEMENT CYCLING

The Oven Temperature Sensor at the back of the oven continuously senses and controls the temperature inside the oven. To keep a constant set temperature, the elements will cycle on and off during cooking.

BAKEWARE PLACEMENT

If baking with more than one pan, place the pans so each has at least 1 to 1 1/2" of air space around it. Place pans so one is not directly above the other.

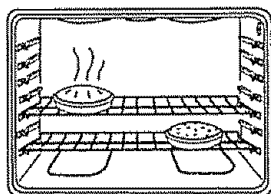

BAKEWARE

FLAT COOKIE SHEETS, without sides, allow air to circulate all around the cookies for even browning.

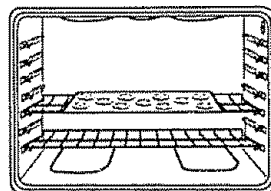

SHINY PANS reflect heat, and are perfect for cakes and quick breads that

need a light brown crust.

GLASS, DARK NON-STICK OR DARKENED BY AGE BAKEWARE, absorb heat, and can be used for yeast breads, pie crust or foods that need a brown crust. The oven temperature, when using these pans should be reduced by 25°F.

OVEN RACKS

The oven racks are designed with stop locks, a convenience as well as a safety precaution. The guides have a bump to prevent the racks from tilting when racks are pulled out of the oven.

Bump in rack guide



Your oven has six (6) rack positions. The area above the top guide cannot be used for a rack position.

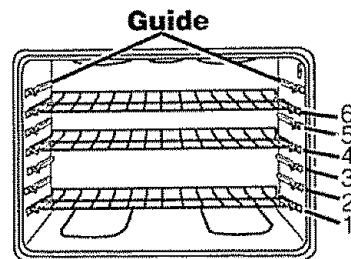

Always place oven racks in the proper position while oven is cool.

OVEN TEMPERATURE ADJUSTMENT

You may feel that your new oven cooks differently than the oven it replaced. We recommend that you use your new oven a few weeks to become more familiar with it, following the times given in your recipes as a guide. See Do It Yourself Temperature Adjustment in the back of this manual to make the adjustment if you feel your oven is too hot or too cool for your cooking preference.





OPERATION

Baking

HOW TO SET BAKE



1. Press the **BAKE** pad.



TEMP



2. Press the **TEMP UP** and/or **DOWN** arrow pads to set the oven temperature you prefer to use.



3. Press the **START** pad.

HOW TO SET TIMED BAKE

To set the oven to cook for a specific time and turn off automatically.



1. Press the **BAKE** pad.



TEMP



2. Press the **TEMP UP** and/or **DOWN** arrow pads to set the oven temperature you prefer to use.



3. Press the **OVEN COOKING TIME** pad.



HOUR MIN



4. Press the **HOUR/MIN UP** and/or **DOWN** arrow pads to set the amount of time you prefer your foods to cook.



5. Press the **START** pad.

HOW TO SET DELAYED START TIME WITH TIMED BAKE

To set the oven to turn on at a later time of day, cook for a specific amount of time and turn off automatically.



1. Press the **BAKE** pad.



TEMP



2. Press the **TEMP UP** and/or **DOWN** arrow pads to set the oven temperature you prefer to use.



3. Press the **OVEN COOKING TIME** pad.



HOUR MIN



4. Press the **HOUR/MIN UP** and/or **DOWN** arrow pads to set the amount of time you prefer your foods to cook.



5. Press the **DELAY START TIME** pad.



HOUR MIN



6. Press the **HOUR/MIN UP** and/or **DOWN** arrow pads to set the time of day you prefer the oven to turn on.



7. Press the **START** pad.

These oven operations may be used when roasting.

The oven will cut off at the end of the cooking time unless the cook and hold feature has been activated.



OPERATION

Broiling

Broiling is cooking by direct heat from the upper element. The oven door should remain open to the broil stop position during broiling.

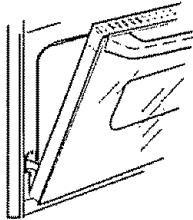

It is not necessary to preheat the oven when broiling. Use the broiler pan and grid that came with your oven. Both are designed for proper drainage of fat and liquids.



If foil is used it must be molded tightly to the grid and slits cut into the foil to match those of the grid. This allows fats and liquids to drain into the broiler pan, preventing fire and excessive smoke.

Always remove the pan and grid from the oven. Storing or forgetting a soiled broiler pan in the oven is a potential smoke or fire hazard.



The U.S. Department of Agriculture recommends to cook meat and poultry thoroughly—meat to at least an INTERNAL temperature of 160° F and poultry to at least an INTERNAL temperature of 180° F. Cooking to these temperatures usually protects against food-borne illness.

The closer you place foods to the broil element, the faster foods brown on the outside yet remain red to pink in the center.

Moving meats away from the element will allow the meat to cook to the center while browning on the outside. Cook side 1 at least 2 minutes longer than side 2. If your oven is connected to 208 volts, you may want to use a higher rack position and/or broil foods longer.

The size, weight, thickness, starting temperature and your preference of the doneness of the meat will affect broiling. This chart is based on meats at refrigerator temperature.

FOOD	RACK POSITION	TOTAL TIME (MIN.)
Steak 1" thick	3	9-11
Ground beef patties 1" thick	3	16-18
Pork Chops - 1/2" thick	3	27-29
Fish (fillets)	3	11-13
Chicken (pieces)	2	45-55

HOW TO SET BROIL

- 1a.** Press the **BROIL** pad. **(This will automatically set Hi Broil).**
- 1b.** While the set indicator is flashing in the display, press the **BROIL** pad again if you prefer to use Lo Broil. Use Lo Broil to cook foods such as poultry or thick cuts of meat thoroughly without over-browning them.
- 2.** Press the **START** pad.
- 3.** When broiling is finished, press the **CLEAR/OFF** pad.



OPERATION

Setting Special Features

Your new touch pad control has additional features that you may choose to use. After making your selection, if you want to change the setting, follow the steps until the display shows your choice.

12 HOUR BAKING AND 3 HOUR BROILING SHUT-OFF

The control is automatically set to turn off the oven after 12 hours baking or 3 hours broiling should you forget and leave the oven on. If you want to remove this feature:

1. Press and hold, **at the same time**, the **BAKE** and **BROIL** pads for 3 seconds, until the display shows **SF**.
2. Press the **DELAY START TIME** pad. The display shows **12shdn** (12 hour shut-off).
Press the **DELAY START TIME** pad again. The display will show **no shdn** (no shut-off).
3. Press the **START** pad.

FAHRENHEIT OR CELSIUS TEMPERATURE SELECTION

Your oven control is set for the Fahrenheit temperature selections. Most recipes are given using the Fahrenheit scale. You can change this to use the Celsius selection.

1. Press and hold, **at the same time**, the **BAKE** and **BROIL** pads for 3 seconds, until the display shows **SF**.
2. (a) Press the **BROIL** pad. The control display will show the degrees sign and **F**.
(b) Press the **BROIL** pad again. This will change **F** (Fahrenheit) to **C** (Celsius).
3. Press the **START** pad.

12 HOUR, 24 HOUR MILITARY TIME CLOCK OR CLOCK BLACK OUT

Your control is set to use the 12 hour clock. If you prefer to use the 24 hour Military Time clock or black out the display:

1. Press and hold, **at the same time**, the **BAKE** and **BROIL** pads for 3 seconds, until the display shows **SF**.
2. (a) Press the **CLOCK** pad. The display shows **12hr**. If this is your choice press the **START** pad.
or
(b) Press the **CLOCK** pad again. The display will show **24hr**.
Example: 5:00 on the 12 hour clock will show 17:00 hours on the military clock. If this is your choice press the **START** pad.
or
(c) Press the **CLOCK** pad again. The display will show **OFF**. If this is your choice press **START**. The display will not show time. (The Delay Start Time feature will not operate.)

OPTIONS FOR SELF-CLEANING

- You can set both ovens for self-clean at the same time, but the second oven will automatically delay the start time to begin at the end of the first oven's clean cycle.
- You can set delay start in both ovens at the same time, but the second oven will automatically delay the start time to begin at the end of the first oven's clean cycle.
- You can set one oven to begin its clean cycle now and set delay start in the second oven for a later time.



OPERATION

Setting Special Features

CONTROL LOCKOUT

Your control will allow you to lock the touch pads so they cannot be activated when pressed. If you're worried about leaving the oven unsupervised, activate this feature.

1. Press and hold, **at the same time**, the **BAKE** and **BROIL** pads for 3 seconds, until the display shows **SF**.
2. (a) Press the **CLEAN** pad. The display shows **LOC OFF** (lockout off).
(b) Press the **CLEAN** pad **again**. The display will show **LOC ON** (lockout on).
3. Press the **START** pad.

This feature can only be set when the oven is not in use.

When this feature is on, the display will show **LOC**, if a touch pad is pressed. (This feature will not affect the Clock, Timer or Oven light pads.)

COOK AND HOLD

Your new control has a cook and hold feature for timed cooking only that will keep hot cooked foods warm up to 3 hours after the timed cooking is finished. To activate this feature:

1. Press and hold, **at the same time**, the **BAKE** and **BROIL** pads for 3 seconds, until the display shows **SF**.
2. (a) Press the **OVEN COOKING TIME** pad. The display will show **HLd OFF**.
(b) Press the **OVEN COOKING TIME** pad **again** to activate the feature. The display will show **HLd ON**.
3. Press the **START** pad.

CHANGING THE SPEED OF THE UP OR DOWN ARROW PADS

This special feature will allow you to change the speed; #1 means speed of change is slow up to #5 which means speed of change is fast. To set the speed you prefer, follow these steps:

1. Press and hold, **at the same time**, the **BAKE** and **BROIL** pads for 3 seconds, until the display shows **SF**.
2. Press the **UP** arrow pad. The display will show the current set speed.
3. Press the **UP** arrow to increase the speed up to the number 5.
or
Press the **DOWN** arrow pad to decrease the speed down to the number 1.
4. Press the **START** pad.



CARE AND CLEANING Self-Cleaning Cycle

PREPARING YOUR OVEN FOR A SELF-CLEAN CYCLE

1. Remove the broiler pan and grid, oven racks, utensils and any foil that may be in the oven.
2. Soil on the front frame, 1" inside the oven, and outside the door gasket will need to be cleaned by hand.

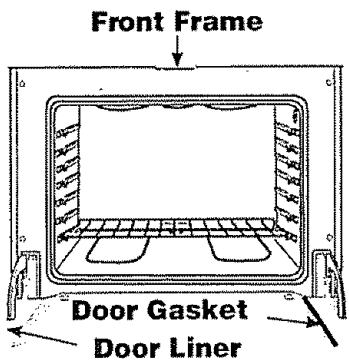

Clean these areas with hot water, soap-filled steel wool pads or cleansers such as Soft Scrub® to remove any soil. Rinse well with clean water and dry.

3. Wipe up any heavy spillovers on the oven bottom.
4. Do not clean the door gasket. The fiberglass material of the oven door gasket cannot withstand abrasion. It is essential for the gasket to remain intact. If you notice it becoming worn, frayed or displaced on the door, it should be replaced.

OVEN DOOR GASKET

The door gasket is designed to have a 5-6" gap at the bottom of the door. This allows for proper air circulation.

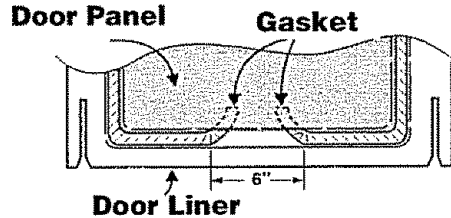

It is normal for your oven door to give the appearance of not having a good seal against the oven. This is due to the gasket. The location of the gasket on the oven door maintains a good seal and prevents any heat loss.



Utensils should never be left in the oven during a self-clean cycle.

The oven racks may be cleaned during the self-clean cycle, but will lose their luster and become hard to slide. If you choose to leave them in during the cycle, wiping them down with vegetable oil after the cycle will help them slide easier.

For the first clean cycle, vent the room with an opened window or hood vent. This will reduce the odor when heating new parts.

Kenmore

CARE AND CLEANING

Self-Cleaning Cycle

TO SET A CLEAN CYCLE

The Clean Cycle, including cool down time, is automatically set for 4 hours, but you may change this from 3 hours if oven is lightly soiled, up to 5 hours if oven is heavily soiled.



1. Press the **CLEAN** pad. 4 hours will show in the display.

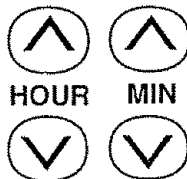

2. If you want to change the length of clean time press the **HOUR/MIN UP** and/or **DOWN** arrow pad.



3. Press the **START** pad.

TO STOP A CLEAN CYCLE

Simply press the **CLEAR/OFF** pad. You will need to wait for the oven temperature to drop below the lock temperature (approx. 1 hour) before attempting to open the door.

AFTER THE CYCLE

After the cycle, you may notice some white ash in the oven. Just wipe it up with a damp cloth or sponge.

If white spots remain, scrub them with a soap-filled steel wool pad. Be sure to rinse thoroughly. These are usually deposits of salt that cannot be removed during the cycle.

If for any reason you are not satisfied with the cleaning results, just repeat the cycle.

TO SET A DELAYED START CYCLE



1. Press the **CLEAN** pad.

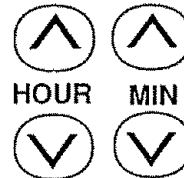

2. If you want to change the length of clean time press the **HOUR/MIN UP** and/or **DOWN** arrow pads.



3. Press the **TIME DELAY START** pad.

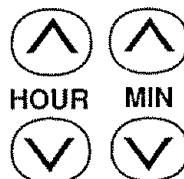

4. Press the **HOUR/MIN UP** and/or **DOWN** arrow pads to set the time you prefer the clean cycle to start.



5. Press the **START** pad.



CARE AND CLEANING

Cleaning and Removable Parts

CONTROL PANEL

CLEANING MATERIALS

- Dishwashing detergent
- Warm water
- Soft cloth

Do not use abrasive cleaners, industrial cleaners or bleach.

BROILER PAN AND GRID

CLEANING MATERIALS

- Dishwashing detergent
- Warm water
- Soap-filled scouring pad
- Commercial oven cleaner

TO CLEAN

Allow the pan to soak. Sprinkle the grid with dishwashing detergent and cover with a damp cloth or paper towel. Rinse and dry well. Scour as needed. You may also place both the pan and grid in the dishwasher.

SELF-CLEAN OVEN INTERIOR

Clean only as touch up between clean cycles. Use dishwashing liquid, warm water, or a soap-filled steel wool pad. Rinse well after cleaning and dry.

NEVER USE OVEN CLEANERS IN OR AROUND ANY PART OF THE OVEN.

When cleaning, be sure not to bend or displace the temperature sensor located on the back wall of the oven.

REPLACING THE OVEN LIGHT BULB



CAUTION: Disconnect electrical power to the oven at the main circuit breaker or fuse box before attempting to replace the oven light bulb. Do not touch a hot light bulb with wet hands or a wet cloth. Wait until the bulb has cooled and use a dry cloth.

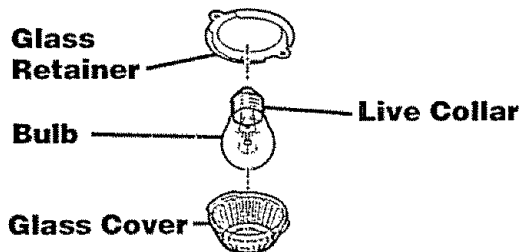

TO REMOVE THE COVER

1. Disconnect electrical power to the oven at the main circuit breaker or fuse box.
2. Grasp the glass cover and turn 1/4 turn counterclockwise until the tabs of the glass cover clear the grooves of the glass retainer.

REPLACE THE LIGHT BULB

Unscrew the light bulb and replace it with a 40-watt appliance bulb.

TO REPLACE COVER

1. Place the tabs of the glass cover into the grooves of the glass retainer.
2. Turn the glass cover 1/4 turn in the clockwise direction.
3. Reconnect the electrical power to the oven.

For improved lighting inside the oven, clean the glass cover frequently using a wet cloth. **Caution: This should only be done when the oven is completely cool.**



CARE AND CLEANING

Cleaning and Removable Parts

REMOVABLE OVEN RACKS

CLEANING MATERIALS

- Dishwashing detergent
- Warm water
- Scouring pad or soap-filled steel wool pad

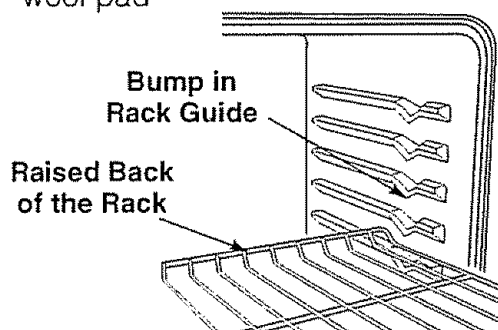

TO REMOVE

1. Pull the racks out to the stop lock position.
2. Pull up the front of the rack and slide under the bump of the rack guide.

TO CLEAN

Clean with warm water and detergent. For hard to remove stains, gently scrub with a scouring pad or a soap-filled steel wool pad. Rinse well.

TO REPLACE

1. Place the raised back of the rack onto the rack guides.
2. Lift the front of the rack until the raised back slides under the bump of the rack guides.
3. Slide the rack all the way back.

REMOVABLE OVEN DOOR

Broil Stop Position

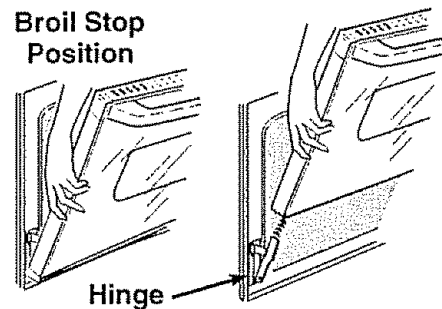

TO REMOVE

1. Open the door to the broil stop position.
2. Grasp the door at each side and lift up and off the hinges. **DO NOT LIFT DOOR BY THE HANDLE.**



CAUTION: When the door is removed and the hinge arms are at the broil stop position, as a precaution, cover the hinge arms with toweling or an empty paper towel roll. Do not bump or try to move the hinge arms while working in the oven area. They could snap back causing injury to the hands or damage the porcelain finish of the front frame.

TO REPLACE

1. Make sure the hinge arms are in the broil stop position
2. Lift the door by the sides.
3. Line up the slots at the bottom edge of the door with the hinge arms.
4. Slide the door down onto the hinge arms as far as it will go.
5. Close the door.



BEFORE CALLING FOR SERVICE

To save you time and money, before making a service call check the list below for any problem you may feel you have with the performance of your oven. If the problem is something you cannot fix use the Consumer Service Numbers located at the back of this manual. **When making any calls have the Model No., Repair Parts list, Use and Care Manual and the Date of Purchase available.**

PROBLEM	POSSIBLE CAUSE	POSSIBLE SOLUTION
The display of your control is flashing "F" followed by a number or letter.	Oven malfunction.	Press the CLEAR/OFF pad. Let the oven cool for 1 hour and enter an oven or cleaning operation. If code repeats, call for service.
Oven and oven control will not work.	No power to oven.	Check the circuit breaker or fuse. Make sure the power cord is plugged in.
	The clock is in the black-out mode.	See the "Setting Special Features" section of this manual.
Oven temperature seems inaccurate.	Thermostat calibration.	See the adjustments described following this section.
Oven will not unlock.	Clean cycle is not finished.	Oven temperature must drop below the lock temperature before the door will unlock.
Oven light will not work.	a. Light switch in off position.	a. Check oven light switch on the control panel.
	b. Oven light bulb burned out.	b. Check the oven light bulb.
Oven did not clean or results were poor.	a. Controls were not set properly.	a. Check the self-cleaning section of this manual.
	b. Clean cycle was interrupted.	b. The normal clean cycle should last 4 hours.
	c. Oven was soiled heavily.	c. Heavy spillovers should be removed before the cycle is set. You can also repeat the cycle.



BEFORE CALLING FOR SERVICE

PROBLEM	POSSIBLE CAUSE	POSSIBLE SOLUTION
Oven smokes.	<ul style="list-style-type: none">a. Dirty oven.b. Improper use of aluminum foil.c. Broiler pan containing grease left in the oven.	<ul style="list-style-type: none">a. Check for heavy spillover.b. Use of foil not recommendedc. Clean pan and grid after each use
Foods do not bake properly.	<ul style="list-style-type: none">a. Oven is not preheated.b. Improper rack or pan placement.c. Oven vent blocked or covered.d. Improper use of foil.e. Improper temperature setting for utensil used.f. Recipe not followed.g. Improper oven control calibration.h. Oven and oven rack not level.	<ul style="list-style-type: none">a. Be sure to preheat until the tone sounds.b. Maintain uniform air space around pans and utensils. See oven cooking section.c. Keep vent clear.d. Racks should not be covered during baking.e. Reduce temperature 25 degrees for glass or dull/darkened pans.f. Check recipe and measurement.g. Check the temperature adjustment following this section.h. Check the installation instructions for leveling.
Foods do not broil properly.	<ul style="list-style-type: none">a. Improper rack positionb. Oven preheated.c. Improper use of foil.d. Oven door closed during broiling.e. Low voltage (208 Volts).f. Improper broiling time.	<ul style="list-style-type: none">a. Check broil pan placement; see broiling section.b. Do not preheat when broiling.c. Check broiling section.d. Open door to broil stop.e. Use higher rack position and/or longer cooking time.f. Check broiling chart in broiling section.



“DO IT YOURSELF” TEMPERATURE ADJUSTMENT

You may feel that your new oven cooks differently than the oven it replaced. We recommend that you use your new oven a few weeks to become more familiar with it, following the times given in your recipes as a guide

If you think your new oven is too hot (burning foods) or not hot enough (foods are undercooked), you can adjust the temperature yourself. The appearance and texture of foods is a better indicator of oven accuracy than oven thermometers, to check the temperature setting of your new oven. These thermometers can vary by 20-40 degrees. In addition, the oven door must be opened to read these thermometers. Opening the door will change the temperature of the oven.

To decide how much to change the temperature, set the oven temperature 25 degrees higher (if foods are undercooked) or 25 degrees lower (if foods are burning) than the temperature in your recipe, then bake. The results of this “test” should give you an idea of how much the temperature should be changed.

TO MAKE THE ADJUSTMENT



+



1. Press and hold down both the **BAKE** and **BROIL** pads for 3 seconds, until the display shows **SF**.

2. Press the **BAKE** pad. A factory set 2 digit number will show in the display, usually 00.

If you think the oven is not hot enough,



TEMP



- 3a. Press the **TEMP UP** arrow pad to **increase (+)** the temperature up to **+35°F**.

If you think the oven is too hot,

- 3b. Press the **TEMP DOWN** arrow pad to **decrease (-)** the temperature down to **-35°F**.



4. Press the **START** pad.

This increased or decreased temperature setting will remain in memory until the above steps are repeated. A power failure will not affect this setting.

The broil and self-clean temperatures will not be affected.



BUILT-IN WALL OVEN WARRANTY

FULL ONE YEAR WARRANTY ON ALL PARTS

If, within one year from the date of installation, any part fails to function properly due to a defect in material or workmanship, Sears will repair or replace it, at our option, free of charge.

If this product is subjected to other than private family use, the above warranty is effective for only 90 days.

WARRANTY SERVICE IS AVAILABLE BY CONTACTING THE NEAREST SEARS SERVICE CENTER/ DEPARTMENT IN THE UNITED STATES

This warranty gives you specific legal rights, and you may also have other rights which vary from state to state.

Sears Roebuck and Co. Dept. 817 WA Hoffman Estates, IL 60179

**To further add to the value of your Oven,
Buy a Sears Maintenance Agreement.**

Years of Ownership Coverage	1st Year	2nd Year	3rd Year
1. Replacement of Defective Parts	W	MA	MA
2. Annual Preventive Maintenance Check at your request	MA	MA	MA

W - Warranty MA - Maintenance Agreement

Kenmore Wall Ovens are designed, manufactured and tested for years of dependable operation. Yet, any modern appliance may require service from time to time. The Sears Warranty plus the Sears Maintenance Agreement helps provide protection from unexpected repair bills.

The chart above compares the warranty and Maintenance Agreement and shows you the benefits of a Sears Oven Maintenance Agreement.

Contact your Sears Sales Associate or Local Sears Service Center today and purchase a Sears Maintenance Agreement.

For in-home major brand repair service:

Call 24 hours a day, 7 days a week

1-800-4-MY-HOMESM

(1-800-469-4663)

Para pedir servicio de reparación a domicilio –

1-800-676-5811

In Canada for all your service and parts needs call –

Au Canada pour tout le service ou les pièces –

1-800-665-4455

For the repair or replacement parts you need:

Call 7 am–7 pm, 7 days a week

1-800-366-PART

(1-800-366-7278)

Para ordenar piezas con entrega a domicilio –

1-800-659-7084

***For the location of a
Sears Parts and Repair Center
in your area:***

Call 24 hours a day, 7 days a week

1-800-488-1222

***For information on purchasing a Sears
Maintenance Agreement or to inquire
about an existing Agreement:***

Call 9 am–5 pm, Monday–Saturday

1-800-827-6655



The Service Side of SearsSM