



USER GUIDE

AC Plug-In Carbon Monoxide Alarms

Models included in this User Guide:

Kidde Model	Display	AA Backup Batteries	10 Yr Sealed Backup Battery	Low Level CO Alert	Gas Detection	No Chirps At Night
COP	No	Yes	No	No	No	No
COPD	Yes	Yes	No	No	No	Yes
COPDL10	Yes	No	Yes	Yes	No	Yes
COPDLG	Yes	Yes	No	Yes	Yes	Yes

Thank You for Purchasing this Alarm

These models utilize standard 120V AC power, as well as either AA replaceable backup batteries or a 10 yr sealed battery backup. They also contain HUSH™ to temporarily silence nuisance alarms.

Teach children how to respond to the alarm and that they should never play with the unit. This alarm is designed to detect carbon monoxide from any source of combustion in a residential environment. Model COPDLG will also detect Natural Gas or Propane in a residential environment. These models are not designed for use in a recreational vehicle (RV) or boat.

NOTE: Please thoroughly read this user guide and save the document for future reference and to pass on to any subsequent owner. Images are representative only. Actual product may vary slightly.

The National Fire Protection Association (NFPA) and the manufacturer recommend replacing this alarm after ten years.



Scan here to register your device with Kidde for customer support and warranty information.

Product Support: 1-800-880-6788

Please write down the below information and have this at hand when you call.

Model: _____

Date Code (on back): _____

Date of Purchase: _____

Where Purchased: _____

Date to Replace: _____

Contents

1. Carbon Monoxide Alarm: What To Do When The Alarm Sounds4
2. Gas Alarm: What To Do When The Alarm Sounds6
3. Other Alarm Visual And Audible Indicators7
4. Troubleshooting Guide8
5. Introduction, Product Features And Specifications10
6. Limitations Of Carbon Monoxide And Gas Alarms12
7. Recommended Locations And Locations To Avoid.14
8. Alarm Installation15
9. Operation, Testing, And Nuisance18
10. Battery Information20
11. Permanently Disable Alarm / Discharge Battery (10 yr sealed battery models only)	.22
12. General Carbon Monoxide (CO) and Explosive Gas Information23
13. Cleaning Your Alarm.26
14. Service And Warranty27

1. Carbon Monoxide Alarm: What To Do When The Alarm Sounds

The carbon monoxide (CO) alarm pattern is four quick beeps repeating every 5 seconds. The red LED blinks in time with the alarm pattern, and the display (if applicable) will alternate between the number of PPM of CO detected, and the message "CO." On DC power only, after 4 minutes in CO alarm, the alarm pattern will only occur every 60s.

⚠️ WARNING: CARBON MONOXIDE (CO) IS A COLORLESS, ODORLESS, POISONOUS GAS. YOU CAN'T TASTE, SEE, OR SMELL CO, BUT IT CAN KILL IN JUST MINUTES. THIS ALARM WILL SOUND IN A 4-BEEP PATTERN IF LIFE THREATENING LEVELS OF CO ARE DETECTED. IF THE ALARM SOUNDS:

- 1) Immediately evacuate all occupants from the space and go outdoors to fresh air.
- 2) Call emergency responders (911 or fire department) for help; notify the building or vehicle owner, as necessary.

EMERGENCY PHONE #: _____

Always consider a CO alarm to be dangerous. After emergency services responders have arrived, the premises has been aired out, and your alarm remains in its normal condition, it is important to call a qualified appliance technician to investigate for sources of CO from fuel burning equipment and appliances and inspect for proper operation of this equipment. If problems are identified during this inspection, have the equipment serviced immediately. Note any combustion equipment not inspected by the technician and consult the manufacturer's instructions or contact the manufacturer directly for more information about CO safety and this equipment. Make sure that motor vehicles are not or have not been operating in an attached garage or adjacent to the residence.

NOTE: See Section Operation, Testing, And Nuisance, for nuisance alarm situations.

Low Level CO Alert Procedure (if applicable)

The Low Level CO Alert is two quick beeps and two red LED blinks every 10 seconds, repeating. The display (if applicable) will show the CO level (PPM) detected. On DC power only, after 4 minutes the alert pattern will only occur every 60s.

⚠️WARNING: An early carbon monoxide (CO) alert is a signal indicating the presence of low levels of CO. It's designed to prompt early awareness and action—allowing you to address the issue before it escalates into a full alarm.

Even low levels of CO can pose health risks, particularly for individuals with certain pre-existing medical conditions. Children, seniors, and pets are also more susceptible and may begin experiencing symptoms sooner.

Recommended actions:

- 1) Open windows to improve ventilation.
- 2) Attempt to identify and resolve the source of CO before an alarm is triggered.
- 3) If you or a household member has a medical condition that could be affected by the exposure of low CO levels (between 30 and 70 PPM), consult your healthcare provider to understand any potential risks.
- 4) If the unit goes into full alarm, follow the Carbon Monoxide Alarm Procedure outlined at the beginning of Section 1 for emergency response and evacuation.

2. Gas Alarm: What To Do When The Alarm Sounds

The Gas Alarm is a 1.5 second beep with a red LED blink, a half-second pause, repeating. The display will show "GAS". On DC power only, after 4 minutes the alert pattern will only occur every 60s.

▲WARNING: Activation of the Gas Alarm indicates the presence of an explosive gas which can cause an explosion and/or fire.

Know how to respond to a CO or gas emergency.

If the unit alarms for gas:









- 1) Immediately evacuate the premises without doing anything that might cause a spark or flame:
 - Do not activate (turn on or off) any electrical switch, phone, or appliance.
 - Do not start a car.
- 2) Contact your fire department from outside, away from the premises.

PHONE NUMBER.

Always consider a Gas alarm to be dangerous. After emergency services responders have arrived, the premises has been aired out, and your alarm remains in its normal condition, it is important to call a qualified appliance technician to investigate for sources of Gas from fuel burning equipment and appliances and inspect for proper operation of this equipment. If problems are identified during this inspection, have the equipment serviced immediately. Note any combustion equipment not inspected by the technician and consult the manufacturer's instructions or contact the manufacturer directly for more information about Gas safety and this equipment.

NOTE: See Section Operation, Testing, And Nuisance, for nuisance alarm situations.



3. Other Alarm Visual And Audible Indicators







Operational Mode	Display (if applicable)	Visual Indications	Audible Indications	Action / Note
Normal (standby)		AC power: Green LED on continuously. DC power: Green LED blinks approx every 60 sec.		
Test (Test/Hush button press when no alarm condition is present) (Note: Test is very loud, stand a few feet away.)		All models: Red LED blinks in time with alarm pattern.	All models: • Single beep • 4 quick beeps, pause, 4 quick beeps. CO/gas model will also emit the gas alarm pattern twice: 1.5 sec beep, half-sec pause.	Perform Test/Hush button press once a week to verify proper alarm operation.
CO Alarm Memory (unit has experienced a CO alarm event, or a low level CO alert has been detected (model specific.))	Alternating  	2 red LED blinks every 15 sec.	None	NOTE: Alarm memory is retained for 7 days. Push Test/Hush button to clear Alarm Memory.
CO Peak Level Memory (Display models only. Unit has detected 100 ppm or greater, or a low level CO alert has been detected (model specific.))	Alternating (after Peak Level button press)  	2 red LED blinks every 15 sec.	None	* Push Peak Level button to see highest level of CO detected on the display from 31 to 999. If no CO has been detected, the display will alternate between "PCO" and "CLR". * Clear Peak Level Memory by cycling power (remove/replace batteries), or by pushing the Peak Level and Test/Hush buttons at the same time until the display shows "CLR".
Low Level CO Alert (if applicable)		2 red LED blinks every 10 sec. On DC power only, after 4 mins, alert occurs only once every 60 sec.	2 chirps every 10 sec. On DC power only, after 4 mins, alert occurs only once every 60 sec.	Refer to Section 1: "Low Level CO Alert Procedure"
Gas Alarm (if applicable)		1 red LED blink every 2 sec. On DC power only, after 4 mins, alert occurs only once every 60 sec.	1 gas alarm pattern every 2 sec, repeating. On DC power only, after 4 mins, alert occurs only once every 60 sec.	Refer to Section 1: "Gas Alarm Procedure"

Operational Mode	Display (if applicable)	Visual Indications	Audible Indications	Action / Note
CO Alarm HUSH™/Reset		None	After Test/Hush button push: CO alarm pattern stops.	Unit is confirming if CO is present or if it experienced a nuisance situation. Re-alarm means danger. Move to fresh air and call 911.
Gas Alarm Memory (if applicable)		2 red LED blinks every 15 sec.	None	NOTE: Alarm memory is only retained for 24 hrs. Push Test/Hush button to clear Alarm Memory.

4. Troubleshooting Guide

If you are experiencing a problem with your alarm, or a fault, and are unsure of the next action, please contact product support at 1-800-880-6788 before discharging the battery (10 yr sealed battery models) or disposing of your alarm. You may also write us at: Kidde, 1016 Corporate Park Drive, Mebane, NC 27302, or visit our internet address at www.kidde.com.

Trouble Condition	Display (if applicable)	Visual Indications	Audible Indications	Action / Note
No Battery		Amber LED blinks every 6 sec.	Chirp Every 60 Sec.	<ul style="list-style-type: none"> * For AA replaceable battery models, remove the battery pull tab, or install batteries. * For 10 yr sealed battery models, activate the sealed battery backup.
Low Battery	Before button push:  After button push: 	Amber LED blinks every 6 sec.	Chirp every 60 sec.	<ul style="list-style-type: none"> * Push Test/Hush button once to silence for 24 hrs. (Push Test/Hush button again to clear Hush and perform a test.) Note: 7 days after Low Battery begins, the notifications cannot be silenced. * For AA replaceable battery models, replace batteries as soon as possible. * For 10 yr sealed battery models, remove alarm, discharge, dispose unit, and replace as soon as possible.

Trouble Condition	Display (if applicable)	Visual Indications	Audible Indications	Action / Note
CO Fault		Amber LED blinks 2 times every 60 sec.	3 chirps every 60 sec.	* Push Test/Hush button once to start a self-test. * If error continues, remove alarm, dispose unit, and replace as soon as possible. (Remove AA batteries or discharge 10 yr sealed battery before disposal)
Gas Fault (if applicable)		Amber LED blinks 5 times every 60 sec.	3 chirps every 60 sec.	* Push Test/Hush button once to start a self-test. * If error continues, remove alarm, dispose unit, and replace as soon as possible. (Remove AA batteries or discharge 10 yr sealed battery before disposal)
Fatal Fault		Amber LED blinks 3 times every 60 sec.	3 chirps every 60 sec.	* Remove alarm, dispose unit, and replace as soon as possible. (Remove AA batteries or discharge 10 yr sealed battery before disposal)
End of Unit Life	Before button push:  After button push: 	Amber LED blinks 2 times every 60 sec.	2 chirps every 60 sec.	* Push Test/Hush button once to silence for 24 hrs. (Push Test/Hush button again to clear Hush and perform a test.) Note: 7 days after End of Unit Life begins, the notifications cannot be silenced. * Remove alarm, dispose unit, and replace as soon as possible. (Remove AA batteries or discharge 10 yr sealed battery before disposal)
MCU Failure	Blank Screen	None	Constant Tone	* Remove alarm, dispose unit, and replace as soon as possible. (Remove AA batteries or discharge 10 yr sealed battery before disposal)
Stuck Test/ Hush or Peak Level Button		Amber LED blinks 4 times every 60 sec.	3 chirps every 60 sec.	* Push button to dislodge it from being stuck. If button cannot be unstuck, remove alarm, dispose unit, and replace as soon as possible. (Remove AA batteries or discharge 10 yr sealed battery before disposal)

5. Introduction, Product Features And Specifications

Introduction

This alarm detects carbon monoxide using an electrochemical cell. Many times throughout this User Guide, we will refer to Carbon Monoxide as “CO.” When describing a model that detects gas, the words “Gas” or “Explosive Gas” will refer to Natural Gas or Propane.

Ten (10) years after a CO alarm, or seven (7) years after a CO/gas alarm was installed, powered up, and tested, the unit will automatically alert you that it is time to replace the unit. This is called “End of Unit Life” mode. See Troubleshooting Guide. To help identify the date to replace the unit, a label has been affixed to the side of the alarm. Write the “Replace by” date (10 years for CO, or 7 years for CO/gas, from initial power up) in an oil based permanent marker on the label prior to installing the unit. Two labels have been provided that have important information on what to do in case of a CO alarm. Place one label at eye level on a wall near the alarm after it is mounted, and one near a fresh air source such as a door or window, where you plan to gather after the alarm indicates the presence of carbon monoxide.

This Kidde carbon monoxide (CO) or CO/gas alarm is an important part of your family’s home safety plan. As an owner of a CO or CO/gas alarm, there are some basic facts you should know about for your protection.

Many people think that CO or CO/gas alarms operate like smoke alarms. Like smoke alarms, CO and CO/gas alarms monitor the air in your home and sound a loud alarm to warn you of trouble. The way you respond to a CO or gas alarm is quite different than a smoke alarm. That’s because a house fire and a CO or gas problem are distinctly different situations. If your smoke alarm were to alarm, you would quickly be able to judge the level of danger you were in with your senses. You can see and smell the smoke, feel the heat, see, and possibly hear the fire burning. You can also readily see if your smoke alarm is alarming in a non-emergency situation. Because your sense of sight, smell, hearing and touch give you information, you can almost instantly judge what action to take if you hear your smoke alarm.

CO is an invisible, odorless, tasteless and non-irritating gas – completely undetectable to your senses. That’s why it is important to your safety that you have a CO alarm.

Product Features and Specifications (see list of models on page 2):

- Low Level CO Alert (model specific)
- 120VAC (60Hz, 30mA max) powered with either 10 yr sealed battery or 2 AA battery backup
- Digital Backlit Display (model specific)
- No Chirps At Night (model specific)
- Easy installation
- CO Sensor: Electrochemical
- Gas Sensor: Metal Oxide (model specific)
- Temperature Operating Range: 40 °F (4.4 °C) to 100 °F (37.8 °C)
- Humidity Operating Range: 10 to 95% RH, non-condensing
- Audible Alarm: 85+ dB at 10 ft, 3.0 to 3.5 KHz pulsing

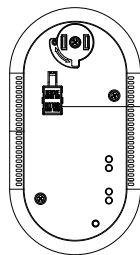
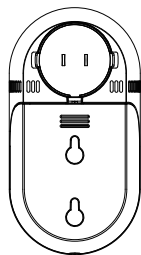
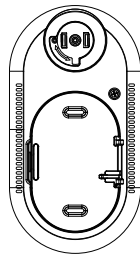
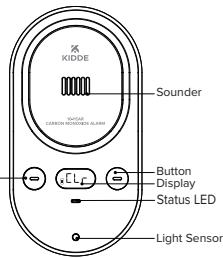
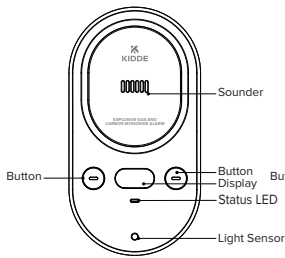
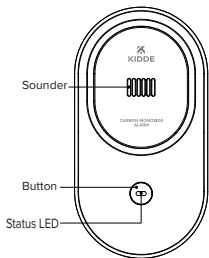

Models with AA Replaceable Batteries

CO/Gas Model COPDLG

Models with 10 Year Sealed Battery

FCC

This device complies with part 15 of the FCC Rules. Operation is subject to the following two conditions: (1) This device may not cause harmful interference, and (2) this device must accept any interference received, including interference that may cause undesired operation.

⚠ CAUTION: The user is cautioned that changes or modifications not expressly approved by the party responsible for compliance could void the user's authority to operate the equipment.

NOTE: This equipment has been tested and found to comply with the limits for a Class B digital device, pursuant to part 15 of the FCC Rules. These limits are designed to provide reasonable protection against harmful interference in a residential installation. This equipment generates, uses, and can radiate radio frequency energy and, if not installed and used in accordance with the instructions, may

cause harmful interference to radio communications. However, there is no guarantee that interference will not occur in a particular installation. If this equipment does cause harmful interference to radio or television reception, which can be determined by turning the equipment off and on, the user is encouraged to try to correct the interference by one or more of the following measures:

- Reorient or relocate the receiving antenna.
 - Increase the separation between the equipment and receiver.
 - Connect the equipment into an outlet on a circuit different from that to which the receiver is connected.
 - Consult the dealer or an experienced radio/TV technician for help.
-

6. Limitations Of Carbon Monoxide And Gas Alarms

WARNING: PLEASE READ CAREFULLY AND THOROUGHLY

- A battery powered alarm must have a battery of the specified type, in good condition and installed properly.
- Alarms must be tested regularly to make sure the battery and the alarm circuits are in good operating condition.
- If the alarm is located outside the bedroom or on a different floor, it may not wake up a sound sleeper.
- The use of alcohol or drugs may also impair one's ability to hear the alarm.

This alarm is not intended to alert hearing impaired individuals.

WARNING: PLEASE READ CAREFULLY AND THOROUGHLY

IMPORTANT: CO alarms are designed to detect carbon monoxide gas from ANY source of combustion. They are NOT designed to detect smoke or fire. CO/gas alarms will also detect the presence of natural gas or propane, but will not detect smoke or fire.

 **WARNING:** Carbon monoxide alarms are not smoke alarms. This carbon monoxide alarm is not a substitute for installing and maintaining an appropriate number of smoke alarms in your home.

This carbon monoxide or CO/gas alarm will not sense smoke or fire even though carbon monoxide can be generated by fire. For this reason you must install smoke alarms to provide early warning of fire and to protect you and your family from fire and its related hazards.

⚠ CAUTION: CO alarms will only indicate the presence of carbon monoxide gas at the sensor. CO/gas alarms will only indicate the presence of carbon monoxide, natural gas, or propane at the sensor. Carbon monoxide, natural gas, or propane gas may be present in other areas. Never restart the source of a CO or gas problem until it has been fixed. NEVER IGNORE THE ALARM!

⚠ WARNING: CO AND CO/GAS ALARMS ARE INTENDED FOR USE IN ORDINARY INDOOR LOCATIONS OF FAMILY LIVING UNITS. THEY ARE NOT DESIGNED TO MEASURE COMPLIANCE WITH OCCUPATIONAL SAFETY AND HEALTH ADMINISTRATION (OSHA) COMMERCIAL OR INDUSTRIAL STANDARDS. THEY ARE NOT SUITABLE FOR INSTALLATION IN HAZARDOUS LOCATIONS AS DEFINED IN THE NATIONAL ELECTRIC CODE. THEY ARE NOT DESIGNED FOR USE IN A RECREATIONAL VEHICLE (RV) OR BOAT.

- The installation of CO or CO/gas alarms should not be used as a substitute for proper installation, use, and maintenance of fuel burning appliances, including appropriate ventilation and exhaust systems.
- CO or CO/gas alarms do not prevent CO, natural gas, or propane from occurring, nor can they solve any existing CO, natural gas, or propane problem.

⚠ WARNING: CO ALARMS ARE DESIGNED TO HELP PROTECT INDIVIDUALS FROM ACUTE EFFECTS OF CARBON MONOXIDE EXPOSURE. THEY WILL NOT FULLY SAFEGUARD INDIVIDUALS WITH SPECIFIC MEDICAL CONDITIONS. IF IN DOUBT, CONSULT A MEDICAL PRACTITIONER. INDIVIDUALS WITH MEDICAL PROBLEMS MAY CONSIDER USING WARNING DEVICES WHICH PROVIDE AUDIBLE AND VISUAL SIGNALS FOR CARBON MONOXIDE CONCENTRATIONS UNDER 30 PPM. *

- These models have not been investigated for carbon monoxide alarm below 70 ppm.
- This device requires a continuous supply of electrical power from a healthy battery or AC connection, depending on the model. It will not work without power.
- CO/gas alarms will detect carbon monoxide primarily and explosive gas secondarily. CO events will take priority over explosive gas events.

* Reference Underwriters Laboratories (UL) standard 2034

7. Recommended Locations & Locations to Avoid

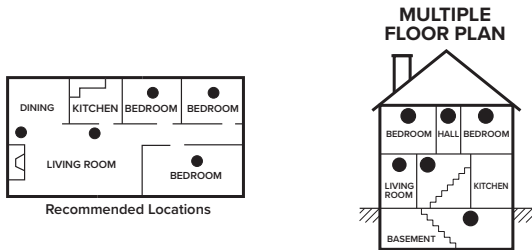

Figure 7

- Industry experts recommend a CO alarm be installed on each level of the home -- ideally on any level with fuel burning appliances and outside of sleeping areas.
- Install an explosive gas alarm where fuel-burning appliances are located such as kitchens, basements, laundry rooms and near gas fireplaces.

Mounting a CO/gas alarm should depend on the type of explosive gas you intend to detect:

- If you are a user of natural gas, mount your CO/gas alarm high on the wall (no closer than six inches from the ceiling) to ensure the earliest opportunity to detect a natural gas leak, because natural gas rises.
- If you are a user of propane, mount your CO/gas alarm near the floor to ensure the earliest opportunity to detect a propane leak, because propane sinks.

Locations To Avoid

- In the garage. Products of combustion are present when you start your automobile.
- Do not install within 6 ft of heating or cooking appliances.
- Do not install in dead air spaces, such as peaks of vaulted ceilings or gabled roofs, where CO may not reach the sensor in time to provide early warning.
- In an area where the temperature may fall below 40 °F (4.4 °C) or rise above 100 °F (37.8 °C), such as crawl spaces, unfinished attics, porches, and garages.
- In dusty areas. Dust particles may cause nuisance alarms or a failure to alarm.

- In very humid areas (above 95% RH, non-condensing) as moisture or steam can cause nuisance alarms.
- In insect-infested areas.
- Alarms should not be installed within 3 ft (0.9m) of the door to a bathroom containing a tub or shower, forced air supply ducts used for heating or cooling, ceiling or whole house ventilating fans, or other high air flow areas.
- Near lights. Electronic “noise” generated by the lights may cause nuisance alarms.
- Do not install near vents, flues, or chimneys.
- Do not install near fans, doors, windows or areas directly exposed to the weather.
- Near deep-cell large batteries. Large batteries have emissions that can cause the alarm to perform at less than optimum performance.
- Do not obstruct the vents located on the alarm. Do not place the alarm where drapes, furniture or other objects block the flow of air to the vents.
- Do not install on a switched or dimmer-controlled outlet.

8. Alarm Installation

STEP 1: ACTIVATE BATTERY

AA replaceable battery models:

Pull out the battery pull tab first to activate the batteries (see Figure 8-A). Battery activation is confirmed with a beep. If the beep does not occur when the battery pull tab is removed, remove the batteries and reinstall them. Confirm the battery activation beep.

10 yr sealed battery models:

The following step must be taken to ensure activation: Battery activation is confirmed with a beep. Confirm the battery activation beep.

Activate the alarm battery by removing the protective cap on the back of the unit and pressing the activation switch. (reference Figures 8-B and 8-C)

NOTE: Activation of the 10 year sealed battery is a one-time operation. After activation, the battery cannot be turned off, and can only be discharged if needed, i.e., due to fault or end of life condition.



Figure 8-A

NOTE: Connecting AC power first, without removing the battery pull tab, or without installing all batteries in the correct orientation, will result in a false low battery trouble condition chirp (see Troubleshooting Guide). You need to activate or install the batteries, or activate the 10 year sealed battery, to eliminate the false low battery trouble condition chirps. Remove the battery pull tab (see Figure 8-A) or install all batteries in the correct orientation (see Figure 10), or activate the 10 year sealed battery (Figures 8-B and 8-C) to avoid false low battery notification. Battery activation is confirmed with a beep. If the beep does not occur when the battery pull tab is removed, or when batteries are replaced, remove the batteries and reinstall them in correct orientation. Confirm the battery activation beep.

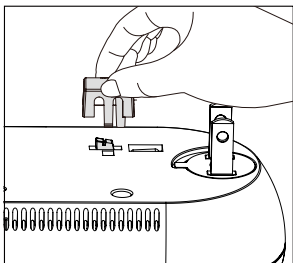

Figure 8-B

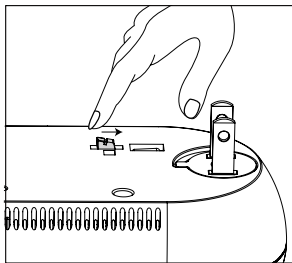

Figure 8-C

STEP 2: INSTALLATION

NOTE: See section “Recommended Locations & Locations to Avoid” for installation locations, including locations for propane and/or natural gas detection.

These alarms are designed to plug directly into a standard, non-switched wall outlet.

NOTE: Do not use an extension cord to power these units.

⚠ WARNING: AC ALARMS CANNOT BE OPERATED FROM POWER DERIVED FROM A SQUARE WAVE, MODIFIED SQUARE WAVE OR MODIFIED SINE WAVE, INVERTER. THESE TYPES OF INVERTERS ARE SOMETIMES USED TO SUPPLY POWER TO THE STRUCTURE IN OFF GRID INSTALLATIONS, SUCH AS SOLAR OR WIND DERIVED POWER SOURCES. THESE POWER SOURCES PRODUCE HIGH PEAK VOLTAGES THAT WILL DAMAGE THE ALARM.

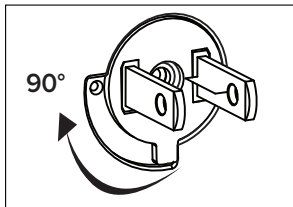

Figure 8-D (excludes model COPDLG)

To install:

- Choose a standard 120V non-switched outlet to plug the alarm into.
- Plug the alarm into the outlet. Note: If the outlet is mounted horizontally (sideways), you will need to rotate the adapter 90°. (Figure 8-D) (excludes model COPDLG)

Note: Model COPDLG includes a removable AC plug and power cord, allowing flexible wall mounting placement for optimal propane and/or natural gas detection. See Recommended Locations section.

For wall mounting, follow these steps:

1. Refer to Figure 8-F distance between holes. Mark the location of two holes on the wall as shown.
2. Insert the two screws provided until the screw heads are protruding approximately 1/8" from the wall. (If mounting in a plasterboard or drywall, drill a 3/16" hole in the wall and use the plastic anchors provided.) (Figure 8-G)
3. Open the battery door, remove the AC plug and extend the cord.
4. Route the cord through the slot (Figure 8-E) and close the battery door.
5. Hook the alarm over the screws and onto the keyholes in the back of the alarm. (Figure 8-H)
6. Plug the AC plug into a non-switched outlet.

NOTE: If either battery is missing (AA battery models), the battery door cannot close.

The alarm is now activated! After installation / activation, test your alarm as described in Operation and Testing section.

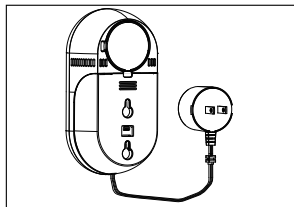

Figure 8-E

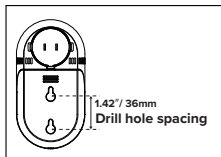

Figure 8-F

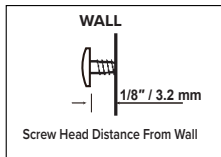

Figure 8-G

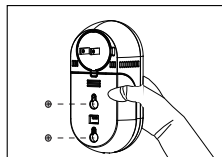

Figure 8-H

⚠ WARNING: Failure to plug in this device into a non-switched 120V outlet and properly install batteries in the correct orientation, or activate the 10 yr sealed battery will prevent proper operation of this alarm and will prevent its response to CO or CO/gas hazards.

IMPORTANT: These alarms are not hardwire interconnected. They do not communicate with other AC hardwire or AC plug-in alarms.

9. Operation, Testing, And Nuisance

OPERATION

The alarm is operating once it is activated and testing is complete (see “TESTING” below). When CO is sensed, the unit sounds a loud alarm. See Section 1 for alarm signal descriptions. In high levels of CO, the unit will go into alarm in a shorter period of time than at low levels of CO.

CO Concentration	CO Alarm (Mins.)
70 PPM	60-240
150 PPM	10-50
400 PPM	4-15

CO Concentration	CO Alert* (Mins.)
70 PPM	≤21
150 PPM	≤ 9
400 PPM	≤ 4

* **NOTE:** These are not the same as CO alarm. See Section 1 for CO alarm and Low Level CO Alert descriptions.

Gas Alarm Response Times:

Before 10% of low explosion limit (LEL) for natural gas or propane is detected.

TESTING

NOTE: When pushing the Test/Hush button, use only your finger or thumb. Using any other instrument(s) (such as a broom handle) is strictly prohibited, as it may damage the alarm.

Test your alarm weekly by pressing and releasing the Test/Hush button for more than one second.

A quick beep will confirm the Test/Hush button has been pushed followed by the test sequence. See

Other Alarm Visual and Audible Indicators table. The alarm will sound if the electronic circuitry, horn, and batteries are working. If the alarm does not sound, or gives erratic or low volume sound, the unit must be replaced.

⚠ WARNING: Due to the loudness of the alarm, always stand about 2.5 ft (0.8 m) away from the unit or use ear protection when testing.

No Chirps At Night (if applicable)

Certain models will sample the ambient light conditions of the alarm's location and, if possible, determine a Night / Day cycle (see list of models on page 2). A valid Night / Day cycle will delay unit chirps during the night until the next Day cycle begins.

Chirping

When End of Unit Life or Low Battery chirping begins, you can temporarily silence these chirps by pressing the Test/Hush button. Other fault /error chirps cannot be silenced. Take appropriate action as described in the Troubleshooting Guide.

⚠ WARNING: REPLACE UNIT AS SOON AS POSSIBLE WHEN IN END OF UNIT LIFE (or IF A 10 YR SEALED BATTERY MODEL GIVES LOW BATTERY NOTIFICATION). SEVEN (7) DAYS AFTER END OF UNIT LIFE BEGINS (or 10 YR SEALED MODEL GIVES LOW BATTERY NOTIFICATION), THE NOTIFICATIONS CANNOT BE SILENCED, AND CO OR CO/GAS DETECTION CANNOT BE GUARANTEED. REPLACE IMMEDIATELY!

NUISANCE ALARMS

HUSH™ / RESET:

Pushing the Test/Hush button during CO alarm allows the unit to reset calculations and double check for the presence of CO. If the unit re-alarms within 6 minutes, it is sensing high levels of CO which can quickly become a dangerous situation. Exit to fresh air and call 911.

⚠ WARNING: ALTHOUGH THE HUSH/RESET FEATURE CAN BE USED FOR CO ALARM EVENTS, IT IS IMPOSSIBLE TO DETERMINE THE SOURCE OF A CO ALARM USING SIGHT OR SMELL. ALWAYS CONSIDER A CO ALARM EVENT AS DANGEROUS.

10. Battery Information

AA Replaceable Battery Models:

These models contain two replaceable AA backup batteries. Under normal conditions, fresh batteries will last at least one year. **NOTE:** Constant exposure to high or low humidity or temperatures may reduce battery life.

⚠ WARNING: THE ALARM IS SEALED AND THE COVER IS NOT REMOVABLE.

NOTE: Display models will give two early notifications of battery status to help plan for timely battery replacement.

1. When the batteries are at approximately half capacity:



2. When the batteries are approaching low battery condition:



Replace batteries with one of the following approved brands,

taking note of the battery polarity shown in Figure 10: Energizer E91, Gold Peak 15A, or Golden Power GLR6A. These batteries can be purchased at your local retailer.

⚠ WARNING: Use only the batteries specified. Use of different batteries may have a detrimental effect on the alarm. Do not mix old and new batteries. Do not mix alkaline, standard, or rechargeable batteries.

NOTE: If either battery is missing (AA battery models), the battery door cannot close.

NOTE: Do not use lithium batteries in this unit. A good safety measure is to replace the batteries at least once a year, or at the same time you change your clocks for daylight saving time. A missing or improperly installed battery will render the unit inoperable.

10 yr Sealed Battery Models:

These models contain a sealed lithium battery backup system. No battery installation or

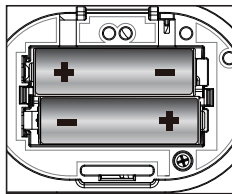

Figure 10

replacement is necessary for the life of the alarm.

NOTE: Constant exposure to high or low humidity or temperatures may reduce battery life.

⚠ WARNING: NO SERVICEABLE PARTS INCLUDED. DO NOT ATTEMPT TO OPEN THE ALARM FOR ANY REASON! DO NOT TRY TO REPAIR THE ALARM YOURSELF.

⚠ CAUTION: THE BATTERY USED IN THIS DEVICE MAY PRESENT A FIRE OR CHEMICAL BURN HAZARD IF MISTREATED. DO NOT RECHARGE, DISASSEMBLE, HEAT ABOVE 100°C (212°F) OR DISPOSE OF IN FIRE.

⚠ WARNING: Failure to plug in this device into a non-switched 120V outlet and properly install batteries in the correct orientation, or activate the 10 yr battery backup, will prevent proper operation of this alarm and will prevent its response to CO or CO/gas hazards.

LOW BATTERY

These alarms are equipped with a low battery monitor circuit. If the battery capacity is nearing the point where it can no longer provide adequate power for all alarm functions, the low battery condition will occur. See Troubleshooting Guide. The batteries must be replaced (replaceable battery models) or the unit must be replaced (10 year sealed battery models) within 7 days of the first occurrence of the “Low Battery Warning” to provide continuous alarm detection.

11. Permanently Disable Alarm / Discharge Battery

(10 yr sealed battery models only)

⚠ WARNING: FAILURE TO DISCHARGE ALARM BATTERY AS INSTRUCTED PRIOR TO DISPOSAL MAY CREATE POTENTIAL FOR LITHIUM BATTERY RELATED FIRE OR HAZARD.

⚠ WARNING: DISCHARGING THE ALARM BATTERY IS PERMANENT.

- Once the alarm battery has been discharged, it cannot be reactivated!
- Once discharged, the alarm will NO LONGER DETECT CO.
- Once the alarm battery is discharged, the battery is depleted and the alarm will no longer function.

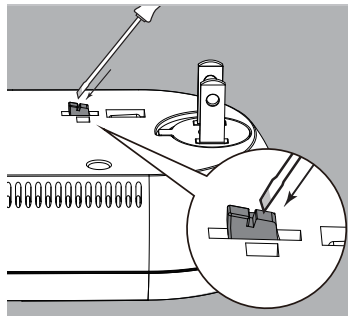

To Permanently Disable Alarm / Discharge Battery:

- Press the discharge switch until it clicks into the discharge position.

Figure 11

12. General Carbon Monoxide (CO) and Explosive Gas Information

Carbon monoxide (CO) is a colorless, odorless, and tasteless poison gas that can be fatal when inhaled. CO inhibits the blood's capacity to carry oxygen.

Possible Sources of CO

Inside your home, appliances used for heating and cooking are the most likely sources of CO. Vehicles and other combustion engines running in an attached garage and using a charcoal/gas grill or hibachi in an enclosed area are all possible sources of CO. Generators running in enclosed areas, such as garages or living spaces, will create CO. CO can be produced when burning any fossil fuel: gasoline, diesel, propane, natural gas, oil and wood. It can be produced by any fuel-burning appliance that is malfunctioning, improperly installed, or not ventilated correctly, such as: Furnaces/boilers, gas ranges/stoves, gas clothes dryers, water heaters, portable fuel burning space heaters, fireplaces, wood-burning stoves and certain swimming pool heaters. Blocked chimneys or flues, back drafting and changes in air pressure, corroded or disconnected vent pipes, or a loose or cracked furnace heat exchanger can also release CO into your building.

The following conditions can result in transient CO situations:

Excessive spillage or reverse venting of fuel-burning appliances caused by outdoor ambient conditions such as: Wind direction and/or velocity, including high gusts of wind, heavy air in the vent pipes (cold/humid air with extended periods between cycles), negative pressure differential resulting from the use of exhaust fans, simultaneous operation of several fuel-burning appliances competing for limited internal air, vent pipe connections vibrating loose from clothes dryers, furnaces/boilers, or water heaters, obstructions in, or unconventional, vent pipe designs which can amplify the above situations, extended operation of unvented fuel-burning devices (range, oven, fireplace, etc.), temperature inversions which can trap exhaust gases near the ground, car idling in an open or closed attached garage, or near a home.

Carbon Monoxide PPM Levels

Display models are equipped with a digital display that shows levels of CO (displayed in PPM – parts per million). Learn the difference between dangerous, high, mid and low levels.

Dangerous Levels:

When someone is experiencing symptoms of CO poisoning and CO readings are generally above 100 PPM. Anytime someone is experiencing the symptoms of CO poisoning this should be treated as an emergency. See “Section 1.”

High Levels:

Generally above 100 PPM, with no one experiencing symptoms. This should be treated as an urgent situation. See “Section 1.”

Mid Levels:

Generally between 50 PPM to 100 PPM. This should be cause for concern and should not be ignored or dismissed. See “Section 1.”

Low Levels:

Generally between 31 and 50 PPM. Kidde recommends you take action to eliminate the source of CO and consult with your healthcare provider to determine the impact of long term exposure to these concentrations on your health. See “Section 1.”

CO Safety Tips

Every year, have the heating system, vents, chimney and flue inspected and cleaned by a qualified technician. Always install appliances according to manufacturer’s instructions and adhere to local building codes. Most appliances should be installed by professionals and inspected after installation. Regularly examine vents and chimneys for improper connections, visible rust, or stains, and check for cracks in furnace heat exchangers. Verify that the color of flame is blue on pilot lights and burners. An amber or orange flame is a sign that the fuel is not burning completely and may be releasing CO. Teach all household members what the alarm sounds like and how to respond. Fire Departments, most utility companies and HVAC contractors will perform CO inspections. Some contractors may charge for this service. It’s advisable to inquire about any applicable fees prior to having the service performed. Kidde will not pay for, or reimburse the owner or user of this product, for any repair or dispatch calls related to the alarm sounding.

Symptoms of CO Poisoning

Initial carbon monoxide poisoning symptoms are similar to the flu with no fever and can include dizziness, severe headaches, nausea, vomiting and disorientation. Everyone is susceptible but experts agree that unborn babies, pregnant women, senior citizens and people with heart or respiratory problems are especially vulnerable. If symptoms of carbon monoxide poisoning are experienced seek

medical attention immediately. CO poisoning can be determined by a carboxyhemoglobin test.

The following symptoms are related to CARBON MONOXIDE POISONING and should be discussed with ALL members of the household:

- 1. MILD EXPOSURE:** Slight headache, nausea, vomiting, fatigue (often described as “Flu-like” symptoms).
- 2. MEDIUM EXPOSURE:** Severe throbbing headache, drowsiness, confusion, fast heart rate.
- 3. EXTREME EXPOSURE:** Unconsciousness, convulsions, cardio respiratory failure and death.

The above levels of exposure relate to healthy adults. Levels differ for those at high risk. Exposure to high levels of carbon monoxide can be fatal or cause permanent damage and disabilities. Many cases of reported carbon monoxide poisoning indicate that while victims are aware they are not feeling well, they become so disoriented they are unable to save themselves by either exiting the building, or calling for assistance. Also, young children and household pets may be the first affected. Familiarization with the effects of each level is important.

Explosive Gas:

Natural Gas is typically supplied through a main utility line connected to your home. If you do not live in a rural area you are likely to be a user of natural gas. Natural gas is much lighter than air and will rise rapidly. If you are a user of natural gas, mount your CO/gas alarm no closer than 6 inches from the ceiling to ensure the earliest opportunity to detect a leak.

Propane is typically supplied to homes via delivery truck in liquid form and stored near the home in propane tanks. Propane and LP-gas (liquefied petroleum) are often used synonymously. Propane is much heavier than air and will collect at lower levels. If you are a user of propane, mount your CO/gas alarm near the floor to ensure the earliest opportunity to detect a leak.

Both propane and natural gas are colorless and odorless. For safety reasons, an odorant (Mercaptan) is added so that any leak can be detected by smell. The common detection threshold for smelling the gases is around 20% of the lower explosion limit (LEL). This can vary greatly depending on the individuals' sense of smell and how long they have been exposed to either gas. The LEL of each of these gases defines the bottom range of flammability for the gas. Your CO/gas alarm is calibrated to alarm before 10% of the LEL of either gas detected. Therefore, it is possible that you may smell gas before the alarm activates.

13. Cleaning Your Alarm

Your Alarm Should be Cleaned at Least Once a Year

You can clean the interior of your alarm by using compressed air or a vacuum cleaner hose and blowing or vacuuming through the openings around the perimeter of the alarm. The outside of the alarm can be wiped with a clean, dry cloth. Do not use water, detergents or cleaners as they may damage the alarm.

- Never use detergent or other solvents to clean the unit.
- Avoid spraying air freshener, hair spray, or other aerosols near the alarm.
- Do not use a hair dryer to clean the alarm, as it may damage the alarm and impact performance.
- Do not paint the unit. Paint will seal the vents and interfere with the sensor's ability to detect CO or CO/gas.
- Never attempt to disassemble the unit to clean inside. This action will void your warranty.

The following substances can affect the CO sensor and may cause false readings and damage to the sensor: Methane, propane, isobutane, iso-propanol, ethyl acetate, hydrogen sulfide, sulfide dioxides, alcohol based products, paints, thinner, solvents, adhesives, hair spray, aftershave, perfume, and some cleaning agents. Move the alarm and place in another location prior to performing any of the following in the near vicinity of the alarm:

Staining or stripping wood floors or furniture

Painting

Wall papering

Using adhesives

In addition, for models with gas detection:

1. Avoid Exposure to Silicone Vapors

Prolonged exposure to silicone vapors can irreversibly affect sensor performance. If silicone compounds adsorb onto the sensor surface, they may form a coating that permanently reduces sensitivity. To prevent this, avoid using the sensor in environments where silicone-based adhesives, hair care products, or silicone rubber/putty are present.

2. Prevent Water Contact and Condensation

Extended contact with water or water condensation on the sensor surface may cause performance drift or degradation. Ensure the sensor is not exposed to high humidity or environments where condensation may occur, especially during storage or operation.

Storing the unit in a plastic bag during any of the above projects will protect the sensors from damage.

When household cleaning supplies or similar contaminants are used, the area must be well ventilated.

 WARNING: REINSTALL THE ALARM AS SOON AS POSSIBLE TO ENSURE CONTINUOUS DETECTION.

14. Service And Warranty

Ten-Year (CO) or Seven-Year (CO/gas) Limited Warranty

Kidde warrants that the enclosed alarm (but not the AA replaceable batteries on AA battery models) will be free from defects in material and workmanship or design under normal use and service for a period of ten years (CO alarms), or seven years (CO/gas alarm) from the date of purchase. The obligation of Kidde under this warranty is limited to repairing or replacing the alarm or any part which we find to be defective in material, workmanship or design (part replacement only, no installation), free of charge, upon receiving the alarm with proof of date of purchase, postage and return postage prepaid, to Warranty Service Department, Kidde, 1016 Corporate Park Drive, Mebane, NC 27302. Before shipping the product, please remove the batteries from the battery compartment, or follow the steps in Permanently Disable Alarm / Discharge Battery section, depending your model type.

This warranty shall not apply to the alarm if it has been damaged, modified, abused or altered after the date of purchase or if it fails to operate due to improper maintenance or inadequate power. Any implied warranties arising out of this sale, including but not limited to the implied warranties of description, merchantability and fitness for a particular purpose, are limited in duration to the above warranty period. In no event shall the Manufacturer be liable for loss of use of this product or for any indirect, special, incidental or consequential damages, or costs, or expenses incurred by the consumer or any other user of this product, whether due to a breach of contract, negligence, strict liability in tort or otherwise.

The above warranty may not be altered except in writing signed by both parties hereto. Your Kidde Alarm is not a substitute for property, fire, disability, life or other insurance of any kind. Appropriate insurance coverage is your responsibility. Consult your insurance agent. Opening the unit will void the warranty. If there are any differences between this printed warranty and the online limited warranty, then the terms of the online warranty supersede those in this user guide or other printed materials. Visit www.kidde.com for the latest warranty statement.



QUESTIONS OR FOR MORE INFORMATION

Call Kidde Product Support line at 1-800-880-6788
or contact us at www.kidde.com

Kidde

1016 Corporate Park Drive, Mebane, NC 27302

©2025 Kidde. All Rights Reserved.



Products conform to UL 2034. Model COPDLG also conforms to UL 1484.