

Product:

460L Side by Side  
Refrigerator

Model Code/s:

ESBS460X

# Esatto

# User Manual

## Exactly what you need

Version:

V1.1 0921

Online:

[esatto.house](http://esatto.house)

# Esatto

# Appliances

Exactly what  
you need

# Contents

---

**Page 4**  
**Welcome**

---

**Page 5**  
**Safety Warnings**

---

**Page 8**  
**Product Overview**

---

**Page 9**  
**Getting Started**

---

**Page 9**  
**Installation**

---

**Page 12**  
**Operation  
Instructions**

---

**Page 13**  
**Usage Tips**

---

**Page 13**  
**Energy  
Saving Tips**

---

**Page 14**  
**Maintenance  
and Cleaning**

---

**Page 16**  
**FAQs and  
Troubleshooting**

---

**Page 19**  
**Specifications**

---

**Page 21**  
**Your Receipt**

---

**Page 20**  
**Purchase Details**

---

**Page 22**  
**Warranty  
Information**

# Welcome

---

**Residentia Group**

—

**Head Office**

165 Barkly Avenue  
Burnley Victoria  
Australia 3121

—

**ACN**

600 546 656

—

**Online**

residentia.group  
www.esatto.house  
f @ @esatto.house

—

**Postage**

PO Box 5177  
Burnley, Victoria  
Australia 3121

—

**Telephone**

1300 11 4357

—

**Email**

support@residentia.group

Congratulations on purchasing your new fridge. The Esatto brand is proudly distributed within Australia by Residentia Group Pty Ltd.

Please refer to the warranty card at the rear of this manual for information regarding your product's parts and labour warranty, or visit us online at: [www.residentiaigroup.com.au](http://www.residentiaigroup.com.au)

At Residentia Group, we are customer obsessed and our Support Team are there to ensure you get the most out of your appliance. Should you want to learn more about your unit such as the various temperature guides or importantly taking care of the appliance, our Support Team are here to help.

You can use our online Support Centre at any time by visiting:  
→ <http://support.residentiaigroup.com.au>

Or you can contact us via phone by dialling: 1300 11 HELP (4357).

It is important that you read through the following use and care manual thoroughly to familiarise yourself with the installation and operation requirements of your appliance to ensure optimum performance.

Again, thank you for choosing Esatto and we look forward to being of service to you.

Kind Regards,  
The Residentia Team



# Safety Warnings

## IMPORTANT SAFETY INSTRUCTIONS READ CAREFULLY AND KEEP FOR FUTURE REFERENCE

Read this manual thoroughly before first use, even if you are familiar with this type of product. The safety precautions enclosed herein reduce the risk of fire, electric shock and injury when correctly adhered to. Make sure you understand all instructions and warnings.

Keep the manual in a safe place for future reference, along with the completed warranty card and purchase receipt. If you sell or transfer ownership of this product, pass on these instructions to the new owner.

Always follow basic safety precautions and accident prevention measures when using an electrical appliance, including the following:

**IMPORTANT:** Pay particular attention to messages that contain the words **DANGER**, **WARNING** or **CAUTION**. These words are used to alert you to a potential hazard that can seriously injure you and others. The instructions will tell you how to reduce the chance of injury and let you know what can happen if the instructions are not followed.



**CAUTION**  
RISK OF FIRE / FLAMMABLE MATERIALS

This symbol alerts you to take care as this appliance contains a flammable refrigerant (isobutane) and insulation blowing gas (cyclopentane). Do not expose it to high heat, sparks and open flames.

The refrigerant isobutane (R600a) is contained within the refrigerant circuit of the appliance, a gas with a high level of environmental compatibility, which is nevertheless flammable. During transportation and installation of the appliance, ensure that none of the components of the refrigerant circuit become damaged.

**WARNING:** Do not damage the refrigerant circuit! Never use an appliance with a damaged refrigerant circuit! If the refrigerant circuit becomes damaged, avoid proximity to open fires and all types of heat and ignition sources. Thoroughly ventilate the room in which the appliance is located.

**DANGER:** It is hazardous for anyone other than an authorised service person to service this appliance. In Queensland, the authorised service person MUST hold a Gas Work Authorisation for hydrocarbon refrigerants to carry out servicing or repairs which involve the removal of covers.

The room for installing the appliance must be at least 1m<sup>3</sup> per 8g of refrigerant. The amount and type of refrigerant in the appliance can be found in the Specifications on page 19 and on the rating plate, found on the appliance.

### Usage Conditions and Restrictions

- **Domestic use only:** This appliance is intended for indoor household use only. It is not intended for commercial, industrial or outdoor use. It is not intended for use in a recreational vehicle.
- **Purpose:** Do not use this appliance for anything other than its intended purpose. Other uses are not recommended and may cause fire, electric shock or personal injury.
- **Attachments:** The use of attachments is not recommended by the appliance manufacturer and distributor as they may be hazardous.
- **Improper use:** Damage due to improper use, or repairs made by unqualified personnel will void your warranty. We assume no liability for any eventual damages caused by misuse of the product or noncompliance with these instructions.

# Safety Warnings (Continued)

---

## General Safety Instructions

- **WARNING:** Do not use mechanical devices or other means to accelerate the defrosting process, other than those recommended by the manufacturer.
- **Usage restriction:** This appliance is not intended for use by persons (including children) with reduced physical, sensory or mental capabilities, or lack of experience and knowledge, unless they have been given supervision or instructions concerning use of the appliance by a person responsible for their safety.
- **Children:** Supervise young children to ensure they do not play with the appliance. Never allow children to operate, play with or crawl inside the appliance.
- **WARNING:** Do not use electrical appliances inside the appliance, unless they are of the type recommended by the manufacturer.
- **Explosive or flammable substances:** Do not store explosive substances such as aerosol cans with a flammable propellant in this appliance. Do not store or use petrol or any other flammable vapours and liquids in the vicinity of this or any other appliance. Do not use such substances for cleaning the appliance. The fumes can create a fire hazard or an explosion.
- **Damage:** Do not use the appliance if the power cord, plug or the appliance itself is damaged. If the cord is damaged, contact the after sales support line and have the cord replaced by qualified personnel in order to avoid a hazard.
- **WARNING:** Do not damage the refrigerant circuit.
- **Do not modify:** Do not attempt to alter or modify this appliance in any way.
- **Repair:** Do not attempt to repair or replace any part of this appliance unless it is specifically recommended in this manual. All other servicing should be referred to a qualified technician. Contact the after sales support line for advice.
- **WARNING:** Do not locate multiple portable socket-outlets or portable power supplies at the rear of the appliance

## Electrical Safety

- **Voltage:** Before connecting and turning on the appliance, ensure the electrical voltage and circuit frequency correspond to that indicated on the appliance rating label.
- **Earthing:** This appliance should be properly earthed for your safety. The power cord of this appliance is equipped with a three-prong plug for use in standard wall outlets to minimise the possibility of electrical shock. Do not modify the cord and/or plug provided with the appliance. Improper use of the earthed plug can result in the risk of electric shock.
- **Connection:** This appliance requires a standard 220-240 V AC 50Hz electrical outlet. Do not overload the electrical circuit.
- **Power cord:** Do not kink or damage the power cord; do not leave it exposed or dangling. Secure it at the back of the appliance so no one steps on or places anything on the cord or against it. Keep the cord out of reach of children. When moving the appliance, make sure not to damage the power cord.
- **WARNING:** When positioning the appliance, ensure the supply cord is not trapped or damaged.
- **Auxiliary Items:** Do not use an inverter, adaptor or extension cord with this appliance. If the cord is too short, have a qualified electrician install an outlet near the appliance. Use of an extension cord and an inverter can negatively affect the performance of the unit.
- **Protect from moisture:** To protect against the risk of electric shock, do not immerse the unit, cord or plug in water or spray it with any other liquid. Do not connect or disconnect the electric plug when your hands are wet. Turn the power switch off before removing the plug from the socket.
- **WARNING: Disconnect!** To reduce the risk of fire, electric shock or personal injury, always unplug the appliance from the socket when not in use, when moving and before cleaning or servicing. Never unplug the unit by pulling the power cord. Always grip the plug firmly and pull straight out from the power point.
- **Electrical work:** Any electrical work required for the installation of this appliance should be carried out by a qualified electrician.

**Never use this appliance with a damaged refrigerant circuit!** If the coolant circuit becomes damaged, avoid proximity to open fires and all types of heat sources. The room in which the appliance is located should be ventilated for a few minutes.

## General Safety Instructions Cont.

### Installation

**Heavy:** This appliance is heavy, take care when moving it. To avoid back or other injury, consider a two person lift or mechanical aid when installing it. Failure to do so can result in back or other injury.

**Damage:** When unpacking, check the appliance carefully for damage. If it is damaged, do not install the appliance. Contact our after sales support centre on 1300 43 57 for advice on examination or return of the damaged appliance.

**Protect from moisture:** Install the appliance in an indoor area protected from wind, rain, water spray or drips.

**Protect from heat:** Do not install the appliance next to an oven, grill or other source of high heat, or where it will be exposed to direct sunlight for prolonged periods of time.

**WARNING: Ventilation:** To ensure proper ventilation, keep any ventilation openings, in the appliance enclosure or in the built-in structure, clear of obstructions. Ensure adequate air circulation around the appliance to prevent overheating.

**Level:** Install the appliance level in order to ensure proper operation.

### Cleaning and Maintenance

**Disconnect:** Unplug the appliance before cleaning or servicing. Failure to do so can result in electric shock, injury or death. Do not connect or disconnect the plug when your hands are wet.

**Flames:** Do not let open flames or ignition sources enter the appliance.

**Flammable/explosive substances:** Never clean this appliance with flammable fluids. Do not store or use volatile, flammable or explosive propellants or liquids in or close to this or any other appliance. The fumes can create a fire hazard or explosion.

**Solvents:** Do not use solvent based cleaning agents or abrasives on the interior as these may damage or discolour the surfaces of the appliances.

**WARNING!** Do not use mechanical devices or other means to accelerate the defrosting process. Never use a sharp or metal instrument to remove frost or clean the appliance. Use a plastic scraper, if necessary.

**Service:** Do not attempt to repair, modify or replace any part of the appliance unless specifically recommended in this manual. Refer all other servicing to a qualified technician, or contact the after sales support line for advice on examination or repair of the appliance.

### Responsible disposal

At the end of its working life, do not throw this appliance out with your household rubbish. Electrical and electronic products contain substances that can have a detrimental effect on the environment and human health if disposed of inappropriately. Observe any local regulations regarding the disposal of electrical consumer goods and dispose of it appropriately for recycling and recovery of the refrigerant and blowing agent. Contact your municipal authorities for advice on recycling facilities in your area. When the appliance is scrapped, disassemble the door and take out the shelves to prevent climbing or entrapment of any children.

**WARNING!** This refrigeration appliance contains flammable refrigerants and insulation blowing gases, which must be removed before disposal. Contact your municipal authorities for any codes or regulations concerning the disposal of such materials.



### Disposal

Do not dispose this product as unsorted municipal waste. Collection of such waste separately for special treatment is necessary. This marking indicates that this product should not be disposed with other household wastes throughout the EU. To prevent possible harm to the environment or human health from uncontrolled waste disposal, recycle it responsibly to promote the sustainable reuse of material resources. To return your used device, please use the return and collection systems or contact the retailer where the product was purchased. They can take this product for environmental safe recycling. For more detailed information about treatment, recovery and recycling of this product, please contact your local city office, your household waste disposal service or the shop where you purchased the product.

# Product Overview

## Your Side by Side Refrigerator

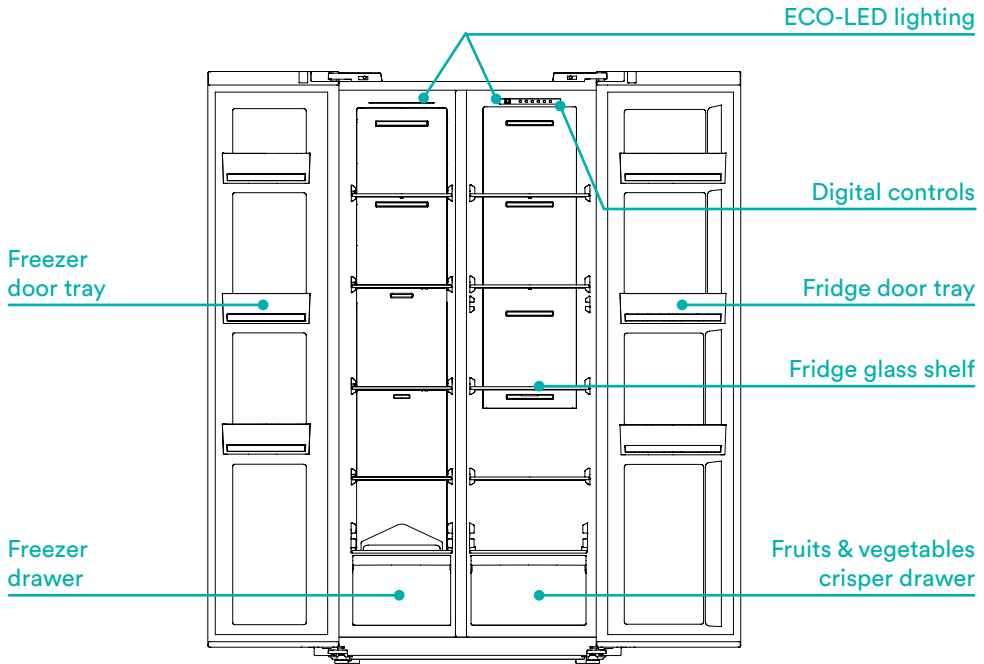

### Refrigerator Compartment

This compartment helps keep for food for short-term storage and is suitable for storing a variety of fruits, vegetables, beverages and other food items ideally between 3 to 5 days.

### Freezer Compartment

This low temperature helps keep food for long-term storage and is suitable for storing frozen food and making ice.

### Storage tips:

- Wait until hot food has cooled to room temperature before placing into the refrigerator.
- For food safety, we recommend sealing up any food before placing into the refrigerator.
- For quicker freezing and easy access, divide your meat and large items into smaller pieces before placing into the freezer compartment.
- The glass shelves can be repositioned up or down to suit your storage requirements.

### Note:

- The diagrams in this user manual are for reference only. Your appliance may appear differently.
- The positioning of the drawers, food boxes and shelving in the diagram above are the most optimal energy efficient.
- Storage of too many items during operation after the initial connection of your appliance to power may adversely affect the freezing effect of the refrigerator.
- Do not block the air outlet or the freezing effect of the refrigerator will also be adversely affected.

# Getting Started

---

## Unpacking Your Fridge

- **Packaging materials:** This appliance has been packaged to protect it against transportation damage. Remove all packaging materials, bottom cushions, foam pads and tapes from around and inside the appliance, tear off the protective film on the doors and refrigerator. Keep the original packaging carton and materials in a safe place. It will help prevent any damage if the product needs to be transported in the future, and you can use it to store the appliance when it is not in use. In the event the carton is to be disposed of, please recycle all packaging materials where possible.
- **Suffocation:** Plastic wrapping can be a suffocation hazard for babies and young children, so ensure all packaging materials are out of their reach and disposed of safely.
- **Power cord:** Unwind the power cord to its full length and inspect it for damage. Do not use the appliance if it or its cord have been damaged or are not working properly. In case of damage, contact our after sales support line for advice on examination, repair or return of the damaged product.
- **Read the manual:** Read this manual to familiarise yourself with the appliance. Pay particular attention to the safety instructions on the previous pages.
- **Clean:** To remove any dust from transit and storage, clean the interior and exterior surfaces of the appliance with lukewarm water and a soft cloth. Dry thoroughly. **Important:** do not use harsh or abrasive detergents or powders as these will damage the finish.

# Installation

---

- **Two person installation:** Use two or more people to move and install the appliance. Failure to do so can result in back or other injury.
- **Freestanding design:** This appliance is designed to be freestanding only, and should not be recessed or built-in.
- **Floor surface:** This appliance must be properly positioned on a dry, sturdy, level surface that is strong enough to support it when it is fully loaded.
- **Clearances:** Ensure that air can circulate freely around the back of the cabinet, which is necessary to cool the compressor and condenser. Allow at least 10cm clear space at the back, 10cm at the sides of the unit and 30cm between the top and any surface above (i.e. a bench top). If you are installing your refrigerator next to a fixed wall, leave sufficient space on the hinge side to allow for the door to swing open.

**DO NOT** install/use the appliance in the following locations/situations:

- In moist areas or areas of high humidity.
- In a recreational vehicle, or for use with an inverter.
- In direct sunlight, near heat sources, next to an open flame, cooking or heating appliance, or near any other source of high heat.
- Direct sunlight may affect the acrylic coating and heat sources may increase the unit's power consumption. For best energy efficiency install the appliance in the coolest area of the room.
- In an area with extreme cold ambient temperatures.
- In an area with excessive moisture and high humidity. Make sure it is protected from elements such as wind, rain, water spray or drips.
- In an area where petrol or other explosive and/or flammable liquids or fumes are used or stored. The fumes can create a fire hazard or explosion.

# Installation (Continued)

## Installation Cont.

### Electrical connection

- **WARNING!** It must be possible to disconnect the appliance from the mains power supply; the plug must therefore be easily accessible after installation.
- Before plugging in your new fridge, let it stand upright for at least 2 hours. This will allow the refrigerant gases to settle into the compressor and reduce the possibility of a malfunction in the cooling system.
- The appliance must be earthed. The plug of the power supply cord is equipped with a contact for this purpose. Do not under any circumstances cut or remove the third (earth) prong from the power cord. If the plug does not fit your outlet, consult a licensed electrician for advice to have the outlet changed.
- Plug the unit into a dedicated, properly earthed wall outlet. Ensure that your outlet voltage and circuit frequency correspond to the voltage stated on the rating label.
- Secure the fridge's supply cord behind the unit. Do not leave it exposed or dangling to prevent injury and accidental disconnection from the power supply.
- Adjust the temperature control as described below.
- When first starting up, and after a period out of use, allow the unit to cool down for at least 2–3 hours (4 hours if starting up during warm weather in summer) before placing food in the fridge.

### Levelling the Fridge

Precautions before levelling the fridge:

- Ensure that the fridge is disconnected from the power source
- Make precautions to prevent any personal injury.

Adjusting procedures:

- a. Turn the feet clockwise to raise the refrigerator;
- b. Turn the feet counterclockwise to lower the refrigerator;
- c. Adjust both feet so the refrigerator is level.

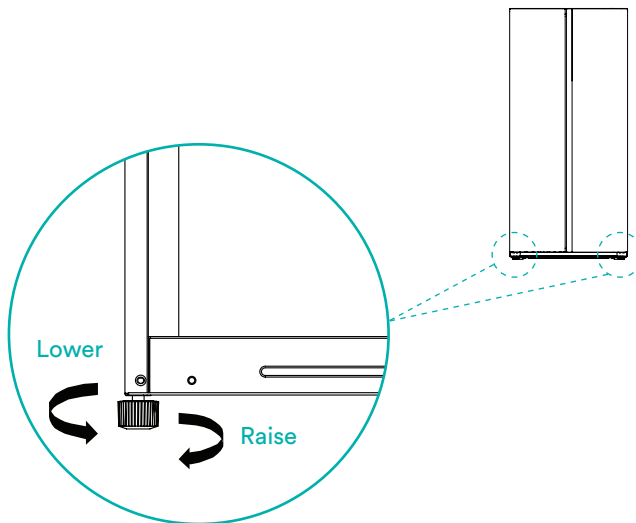

## Installation Cont.

### Levelling the Doors

Precautions before levelling the door body:

- Ensure that the fridge is disconnected from the power source
- Make precautions to prevent any personal injury.

Adjusting procedures:

a. **When the fridge door is too low:**

Open the door and use a wrench to loosen the locking nut. Then rotate the adjusting nut anti-clockwise to raise the height of the door. Once the doors are aligned, retighten the locking nut by turning it anti-clockwise.

b. **When the fridge door is too high:**

Open the door and use a wrench to loosen the locking nut. Then rotate the adjusting nut clockwise to lower the height of the door. Once the doors are aligned, retighten the locking nut by turning it anti-clockwise.

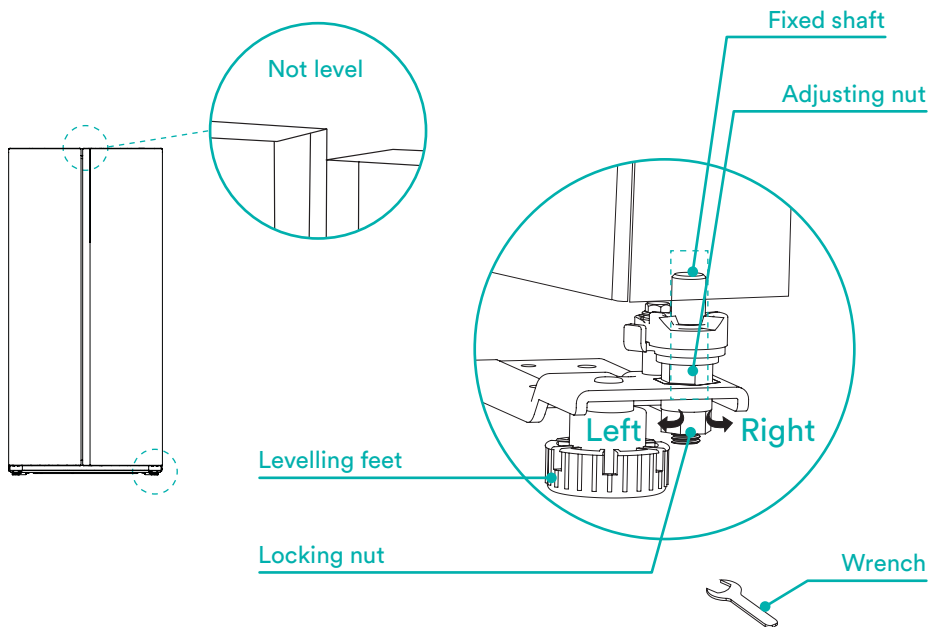

### Note:

The images and diagrams in this user manual are for reference only. Your appliance may appear differently.

# Operation Instructions

The temperature controls are located on the inside of the refrigerator.

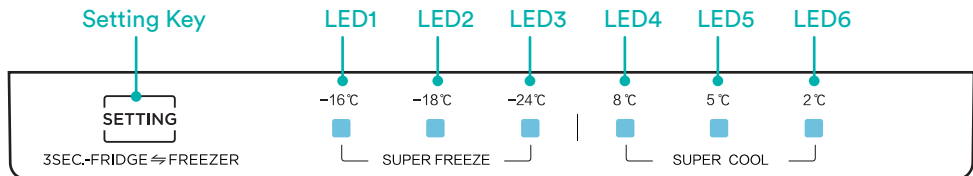

## Note:

The diagram above is for reference only. Your fridge's configuration may appear differently.

## First Time Use

When power is connected for the first time, the full display will be lit for 3 seconds. It will then enter normal operation display. By default, the settings for your refrigerator and freezer is 5°C / -18°C respectively. It is the best to wait 24 hours before adding food.

The display will be on when the refrigerator door is opened, and the display will turn off once the freezer door is closed.

## The Temperature Controls

After each key press, the temperature will adjust and the corresponding set temperature will flash on the display for 3 seconds. To alternate between setting the refrigerator temperature and the freezer temperature, long press the Setting Key for 3 seconds. If there is no interaction for 30 seconds, the set temperature will resume normal operation.

### Setting the Refrigerator Temperature:

Use the Setting Key to cycle through the temperature settings: 2°C, 5°C, 8°C, Super Cool.

Super Cool mode will operator for 6 hours. It is ideal for rapidly cooling the refrigerator compartment.

When in the Super Cool state, LED4 and LED6 will be lit at the same time.

### Setting the Freezer Temperature:

Use the Setting Key to cycle through the temperature settings: -24°C, -18°C, -16°C, Super Freeze.

Super Freeze mode will operator for 24 hours. It is ideal for rapidly cooling the freezer compartment.

When in the Super Freeze state, LED1 and LED3 will be lit at the same time.

## Note:

- The recommended refrigerator compartment setting is 5°C.
- The recommended freezer compartment setting is -18°C.
- During high ambient temperatures (such as hot summer days) it may be necessary to set the thermostat to the coolest setting. This may cause the compressor to run continuously in order to maintain a low temperature.
- When the door is opened, the corresponding light will be turned on. There is no door opening prompt tone or door opening alert.

**IMPORTANT:** Once the unit has started, continuous operation is recommended. Please try and avoid turning the unit off and on as this may affect the service life.

## Usage Tips

---

- Do not store food uncovered in the fridge. Always use good quality, fridge-proof packaging to maintain food quality. Remove air from packages of solid food and seal bags tightly before freezing.
- Keep portions small to ensure they are frozen (and subsequently defrosted) rapidly.
- Make sure that fresh, unfrozen food packages do not touch food that is already frozen, thus avoiding a temperature rise in the frozen food.
- When freezing food, do not push food together too much, leave some space for air to circulate around each item. Do not place packages directly against the back wall.
- When buying frozen food, only buy quantities that you can store straight away; use an insulated container for your shopping and when you get home, place the food in the chilling compartment immediately.
- When storing pre-packed, commercially frozen food, follow the food manufacturer's instructions for storing the food in a home fridge or freezer. Do not exceed any storage times listed on the packaging.
- Once you have opened a packet of frozen food, re-wrap it airtight to prevent surface evaporation which causes drying or freezer burn.
- Do not place carbonated liquids such as bottles of fizzy drink in the freezer compartment as the container could explode under pressure and damage the chiller.
- Do not refreeze food once it has been defrosted.
- Frozen food which has thawed accidentally should either be used immediately or thrown away. Alternatively, if the food is uncooked and has not been completely defrosted, it may be cooked and then refrozen.
- **CAUTION!** Do not remove items from the freezer compartment if your hands are damp or wet as this could cause skin abrasions.
- The gaps between refrigerator doors and refrigerator body are small, be careful not to jam your fingers in these areas.
- Close the refrigerator door gently to avoid falling articles.
- To avoid frostbite, do not pick foods or containers with wet hands in the freezer when the refrigerator is running, especially metal containers.
- Do not place heavy objects on top of the refrigerator to prevent injuries of falling articles.

## Energy Saving Tips

---

- The appliance should be placed in the coolest area of the room, away from heat producing appliances or heating ducts. Please avoid placement in direct sunlight.
- Let hot foods cool to room temperature before placing them in the appliance.
- Do not overload the appliance with unfrozen food as this may cause it to freeze slowly and risk food spoilage.
- Be sure to wrap foods properly and wipe containers dry before placing them in the appliance. This cuts down on frost building up inside in the unit.
- Please do not wrap items in aluminium foil, wax paper or paper towel. This materials interfere with cold air circulation, making the appliance less efficient.
- Organise and label food to reduce door openings and extended searches. Remove as many items as needed at one time, ensuring the unit is opened as few times as possible.

# Maintenance and Cleaning

## Defrosting

The refrigerator has an automatic defrosting function. Frost formed due to change of season or temperature may also be manually removed by disconnecting the appliance from power supply. Alternatively, wipe the surface with a dry towel.

## General Cleaning

### WARNING

Before cleaning the appliance, make sure it is switched off and disconnected from the power supply. Failure to do so can result in electric shock or injury.

- We recommend cleaning the dust away from behind the refrigerator and on the ground to improve the cooling effect and improve energy efficiency.
- Check the door gasket regularly to make sure there is no debris. Clean the door gasket with a soft cloth dampened with soapy water or diluted detergent.
- The interior of the refrigerator should be cleaned regularly to avoid odour.●
- Please turn off the power before cleaning the interior. Remove all foods, drinks, shelves, drawers, etc.
- Wash the inside surfaces and the interior accessories with a damp, warm cloth moistened in a water and baking soda solution. The solution should be about 2 tablespoons of baking soda to 1 litre of water. Rinse and wipe dry with a soft cloth.
- Clean the outside of the unit with a damp, well wrung out cloth, keeping the area of the controls dry. Keep the lid gasket (seal) clean.
- **Never use boiling water to accelerate defrosting as it may damage the plastic components.**
- Regularly check the appliance for defrost water. If necessary, clean the drain. If the drain is blocked, water will collect in the base of the appliance.
- After everything is dry, place appliance back into service.
- Allow approximately 1–2 hours for the cabinet to cool down again (depending on the length of time the appliance was disconnected from the power).

### WARNING

Never clean the unit with an abrasive, acid, oil or solvent based cleaning agent. Never use flammable fluids or sprays for cleaning as the fumes from these substances can create a fire hazard or Explosion.

## Cleaning the door tray

- According to the direction arrow in the figure below, use both hands to squeeze the tray, and push it upward, then you can take it out.
- After washing the tray having been taken out, you can adjust its installation height per your requirement.
- We recommend using soft towels or sponge dipped in water and non-corrosive neutral detergents for cleaning. The freezer can be cleaned with clean water and a dry cloth. Open the door for natural drying before the power is turned on.
- Do not use hard brushes, clean steel balls, wire brushes, abrasives, such as toothpaste, organic solvents (such as alcohol, acetone, banana oil, etc.), boiling water, acid or alkaline items clean refrigerator, considering that this may damage the fridge surface and interior.

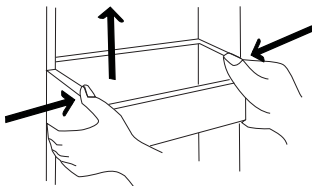

### Note:

The diagram above is for reference only. Your fridge's configuration may appear differently.

### Cleaning the glass shelves

- As the innermost part of the refrigerator liner where contacting the shelves has a backstop, you need to raise the shelves upward before you can take it out.
- After cleaning or adjusting your shelves to your requirements, use soft towels or sponge dipped in water, and non-corrosive neutral detergents are suggested for cleaning. Clean the freezer with clean water and a dry cloth. Open the door for natural drying before the power is turned back on.
- Do not use hard brushes, clean steel balls, wire brushes, abrasives, such as toothpaste, organic solvents (such as alcohol, acetone, banana oil, etc.), boiling water, acid or alkaline items clean refrigerator, considering that this may damage the fridge surface and interior.

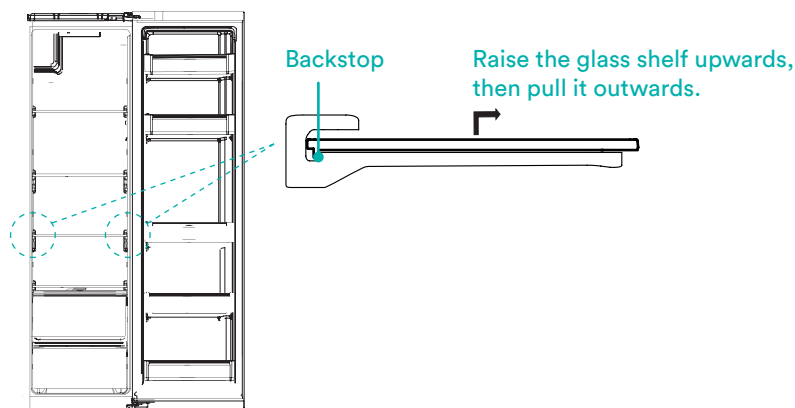

The diagram above is for reference only. Your fridge's configuration may appear differently.

### Service, repair and spare parts

Do not attempt to alter or modify this appliance in any way, or to repair or replace any part unless it is specifically recommended in this manual. All other servicing should be referred to a qualified technician. Contact our after sales support on 1300 11 43 57 for advice.

Our after sales support centre stocks a selection of spare parts for the Esatto 460L Side by Side Refrigerator. To enquire about purchasing a part, call us on 1300 11 43 57 or email [support@residentiagroup.com.au](mailto:support@residentiagroup.com.au)

### Power Failure

- Most power failures are corrected within a few hours and should not affect the temperature of your appliance if you minimise the number of times the door is opened. If the power is going to be off for a longer period of time, take proper steps to protect the contents.
- For long-term periods of turning your friends off. Unplug the appliance and clean it. Keep doors open to prevent any odours.
- Moving: Before moving the refrigerator, take out all objects, fix the glass shelves and drawers with tape, tighten the levelling feet, close the doors and fix them with tape. During the move, do not lay the appliance upside down or horizontally. Avoid vibrations and do not incline the appliances no more than 45°.

### LED Lights

Any replacement or maintenance of the LED lamps must be made by the manufacturer, its service agents or a similar qualified technician. Please contact the after sales support line on 1300 11 HELP (4357) if your lights need replacing. This product contains a light source of energy efficiency glass (G).

# FAQs and Troubleshooting

## Fault Indication

The following warnings may appear on the control panel display indicating the corresponding faults of your appliance. Though the refrigerator may still be in operation with a fault, we highly recommend our after sales support line on 1300 11 HELP (4357) for maintenance to optimise the performance of your appliance.

Fault Code	Fault Description
LED1 & LED 3 are flashing	Freezer temperature sensor fault
LED1 & LED 4 are flashing	Ambient temperature fault
LED1 & LED 5 are flashing	Frozen defrosting sensor fault
LED1 & LED 6 are flashing	Refrigerator temperature sensor fault

## Troubleshooting

Before contacting our after sales support line, please check the troubleshooting table below to see if you are able to solve the problem yourself.

Problem	Possible Cause	Possible Solution
The appliance does not operate.	<ul style="list-style-type: none"> <li>The appliance is not plugged in.</li> <li>The appliance is turned off.</li> <li>The circuit breaker tripped or a blown fuse.</li> </ul>	<ul style="list-style-type: none"> <li>Plug in the appliance.</li> <li>Turn on power point.</li> <li>Reset circuit breaker/replace fuse.</li> </ul>
The appliance is not cold enough.	<ul style="list-style-type: none"> <li>Check the temperature control setting.</li> <li>The door is opened too often, or is kept open for too long; the door is not closed completely; hot food has been placed inside.</li> <li>The appliance has recently been disconnected for a period of time.</li> </ul>	<ul style="list-style-type: none"> <li>Reduce the temperature.</li> <li>Do not open door for 2+ hours; Check that the door is closed properly and for any obstructions preventing the door closing properly; Remove hot food and let it cool first before replacing it.</li> <li>Plug in the appliance.</li> </ul>
The appliance has an odd odour.	<ul style="list-style-type: none"> <li>Food may not be wrapped properly.</li> <li>Food may be rotten.</li> <li>The interior may not be clean.</li> </ul>	<ul style="list-style-type: none"> <li>Check that the food is wrapped tightly.</li> <li>Check for rotten food and remove.</li> <li>Clean the interior of the appliance.</li> </ul>
The internal light does not illuminate.	<ul style="list-style-type: none"> <li>The appliance is not plugged in.</li> <li>The appliance is turned off.</li> <li>The circuit breaker tripped or a blown fuse.</li> <li>The light is damaged.</li> </ul>	<ul style="list-style-type: none"> <li>Plug in the appliance.</li> <li>Turn on power point.</li> <li>Reset circuit breaker/replace fuse.</li> <li>Please contact after sales support.</li> </ul>
The compressor is operating for a long time	<ul style="list-style-type: none"> <li>This is normal with higher ambient temperatures</li> </ul>	<ul style="list-style-type: none"> <li>Reduce the amount of food that is stored in the fridge at the same time</li> <li>Reduce the amount of times you open the fridge door.</li> <li>Let hot food cool first before placing into the fridge.</li> </ul>



Problem	Possible Cause	Possible Solution
The door will not close properly.	<ul style="list-style-type: none"> <li>• The appliance is not level.</li> <li>• Food is stacked too high.</li> </ul>	<ul style="list-style-type: none"> <li>• Level the appliance.</li> <li>• Re-position food so it does not obstruct.</li> </ul>
The door is difficult to open.	<ul style="list-style-type: none"> <li>• A difference in pressure between the air inside and outside of the unit.</li> </ul>	<ul style="list-style-type: none"> <li>• This is a normal phenomenon and cannot be avoided.</li> </ul>
Loud noise	<ul style="list-style-type: none"> <li>• The appliance is not level.</li> <li>• Accessories are placed incorrectly</li> </ul>	<ul style="list-style-type: none"> <li>• Level the appliance.</li> <li>• Re-position accessories to their proper location.</li> </ul>
Door seal is loose	<ul style="list-style-type: none"> <li>• Foreign matters on the door seal</li> <li>• Door seal needs to be heated and cooled for restoration</li> </ul>	<ul style="list-style-type: none"> <li>• Remove foreign matters on the door seal</li> <li>• Use a hot towel to warm the seal</li> </ul>
Water pan overflows	<ul style="list-style-type: none"> <li>• There is a high amount of food that contains water resulting in heavy defrosting.</li> <li>• The door is not closed properly resulting in frosting due to external air and increased water due to defrosting.</li> </ul>	<ul style="list-style-type: none"> <li>• This is normal.</li> <li>• Close the door.</li> <li>• Open the door less often</li> </ul>
Hot housing	<ul style="list-style-type: none"> <li>• Heat dissipation of the built-in condenser via the housing</li> <li>• Housing becomes hot due to high ambient temperature, too much food storage, power failure.</li> </ul>	<ul style="list-style-type: none"> <li>• This is normal.</li> <li>• Provide sound ventilation to facilitate heat dissipation.</li> </ul>
Surface condensation	<ul style="list-style-type: none"> <li>• The door is slightly open, causing cold air from inside the appliance to meet warm, moist air from the outside.</li> <li>• This is normal with higher ambient temperatures</li> </ul>	<ul style="list-style-type: none"> <li>• Close the door or check for obstructions.</li> <li>• Wipe the condensate with a clean towel.</li> </ul>
There are abnormal noises.	<ul style="list-style-type: none"> <li>• The appliance is not level.</li> <li>• The floor is uneven or weak.</li> <li>• The appliance is touching the wall.</li> <li>• The compressor may produce a buzzing sound during operation, especially loud upon start and stop.</li> <li>• Refrigerant flowing inside the appliance.</li> </ul>	<ul style="list-style-type: none"> <li>• Level the appliance.</li> <li>• Be sure your floor can adequately support the appliance.</li> <li>• Move the appliance away from the wall and check it is level.</li> <li>• This is normal.</li> <li>• This is normal.</li> </ul>

This page  
is intentionally  
left blank

# Specifications

<b>Model:</b>	ESBS460X
<b>Product Dimensions:</b>	W: 835mm, D: 635mm, H: 1775mm
<b>Weight (Net/Gross):</b>	81kg/90kg
<b>Storage Volume:</b>	460L
<b>Energy Rating (MEPS):</b>	3 Stars

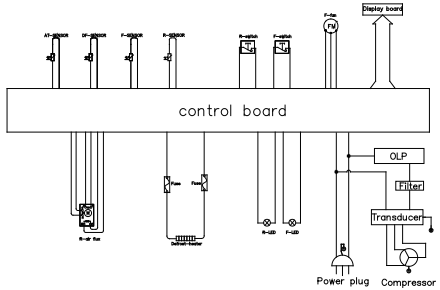
## Rating Label

<h1>Esatto</h1>		<h2>460L Side by Side Refrigerator</h2>	 E2447
<p>MODEL ESBS460X GROUP 5S CLIMATE CLASS T/ST/N/SN CLASSIFICATION OF PROTECTION AGAINST ELECTRIC SHOCK I RATED VOLTAGE 230V~ RATED FREQUENCY 50HZ RATED CURRENT 1.9A ENERGY CONSUMPTION 470kWh/year REFRIGERANT R600a AMOUNT 80g TOTAL STORAGE VOLUME 460L FREEZER STORAGE VOLUME 189L REFRIGERATOR STORAGE VOLUME 271L INSULATION BLOWING AGENT Cyclopentane NET WEIGHT 81kg COMPRESSOR DZ100VIE DIMENSION (WxDxH mm) 835x635x1775 APPROVAL NO: SAA-202510-EA MADE IN P.R.C.</p>	<p><b>ELECTRIC DIAGRAM</b></p> 		
			www.esatto.house 1300 11 4357
		Caution: Risk of fire	

Attach your receipt to this page



# Purchase Details

---

For your records, please record details of your purchase below and staple your receipt on the opposite page.

Your serial number can be found on the rear of your refrigerator

---

## STORE DETAILS

---

STORE NAME |

ADDRESS |

TELEPHONE |

PURCHASE DATE |

---

## PRODUCT DETAILS

---

MODEL NO. |

SERIAL NO.\* |

# Warranty Information

---

## WARRANTY TERMS AND CONDITIONS REFRIGERATION APPLIANCES

This document sets out the terms and conditions of the product warranties for Residentia Group Appliances. It is an important document. Please keep it with your proof of purchase documents in a safe place for future reference should you require service for your Appliance.

### 1. IN THIS WARRANTY

- (a) 'acceptable quality' as referred to in clause 10 of this warranty has the same meaning referred to in the ACL;
  - (b) 'ACL' means Trade Practices Amendment (Australian Consumer Law) Act (No.2) 2010;
  - (c) 'Appliance' means any Residentia Group product purchased by you accompanied by this document;
  - (d) 'ASR' means Residentia Group authorised service representative;
  - (e) 'Residentia Group' means Residentia Group Pty Ltd of 165 Barkly Ave, Burnley VIC 3121, ACN 600 546 656 in respect of Appliances purchased in Australia;
  - (f) 'major failure' as referred to in clause 10 of this warranty has the same meaning referred to in the ACL and includes a situation when an Appliance cannot be repaired or it is uneconomic for Residentia Group, at its discretion, to repair an Appliance during the Warranty Period;
  - (g) 'Warranty Period' means:
    - (i) where the Appliance is used for personal, domestic or household use (i.e. normal single family use) as set out in the instruction manual, the Appliance is warranted against manufacturing defects for 24 months, following the date of original purchase of the Appliance;
  - (h) 'you' means the purchaser of the Appliance not having purchased the Appliance for re-sale, and 'your' has a corresponding meaning.
2. This warranty only applies to Appliances purchased and used in Australia and is in addition to (and does not exclude, restrict, or modify in any way) any non-excludable statutory warranties in Australia.
  3. During the Warranty Period Residentia Group or its ASR will, at no extra charge if your Appliance is readily accessible for service, without special equipment and subject to these terms and conditions, repair or replace any parts which it considers to be defective. Residentia Group or its ASR may use remanufactured parts to repair your Appliance. You agree that any replaced Appliances or parts become the property of Residentia Group. This warranty does not apply to light globes, batteries, filters or similar perishable parts.
  4. Parts and Appliances not supplied by Residentia Group are not covered by this warranty.

5. You will bear the cost of transportation, travel and delivery of the Appliance to and from Residentia Group or its ASR. If you reside outside of the service area, you will bear the cost of:
  - (a) travel of an authorised representative;
  - (b) transportation and delivery of the Appliance to and from Residentia Group or its ASR, in all instances, unless the Appliance is transported by Residentia Group or its ASR, the Appliance is transported at the owner's cost and risk while in transit to and from Residentia Group or its ASR.
6. Proof of purchase is required before you can make a claim under this warranty.
7. You may not make a claim under this warranty unless the defect claimed is due to faulty or defective parts or workmanship. Residentia Group is not liable in the following situations (which are not exhaustive):
  - (a) the Appliance is damaged by:
    - (i) accident
    - (ii) misuse or abuse, including failure to properly maintain or service
    - (iii) normal wear and tear
    - (iv) power surges, electrical storm damage or incorrect power supply
    - (v) incomplete or improper installation
    - (vi) incorrect, improper or inappropriate operation
    - (vii) insect or vermin infestation
    - (viii) failure to comply with any additional instructions supplied with the Appliance;
  - (b) the Appliance is modified without authority from Residentia Group in writing;
  - (c) the Appliance's serial number or warranty seal has been removed or defaced;
  - (d) the Appliance was serviced or repaired by anyone other than Residentia Group, an authorised repairer or ASR.
8. This warranty, the contract to which it relates and the relationship between you and Residentia Group are governed by the law applicable where the Appliance was purchased.
9. To the extent permitted by law, Residentia Group excludes all warranties and liabilities (other than as contained in this document) including liability for any loss or damage whether direct or indirect arising from your purchase, use or non use of the Appliance.
10. For Appliances and services provided by Residentia Group in Australia, the Appliances come with a guarantee by Residentia Group that cannot be excluded under the Australian Consumer Law. You are entitled to a replacement or refund for a major failure and for compensation for any other reasonably foreseeable loss or damage. You are also entitled to have the Appliance repaired or replaced if the Appliance fails to be of acceptable quality and the failure does not amount to a major failure. The benefits to you given by this warranty are in addition to your other rights and remedies under a law in relation to the Appliances or services to which the warranty relates.
11. At all times during the Warranty Period, Residentia Group shall, at its discretion, determine whether repair, replacement or refund will apply if an Appliance has a valid warranty claim applicable to it.
12. Missing parts are not covered by warranty. Residentia Group reserves the right to assess each request for missing parts in a case by case basis. Any parts that are not reported missing in the first week after purchase will not provide free of charge.
13. To enquire about claiming under this warranty, please follow these steps:
  - (a) carefully check the operating instructions, user manual and the terms of this warranty;
  - (b) have the model and serial number of the Appliance available;
  - (c) have the proof of purchase (e.g. an invoice) available;
  - (d) telephone the numbers shown below.
14. You accept that if you make a warranty claim, Residentia Group and its ASR may exchange information in relation to you to enable Residentia Group to meet its obligations under this warranty.

#### IMPORTANT

Before calling for service, please ensure that the steps in point 13 have been followed.

#### CONTACT SERVICE

→ Please call 1300 11 HELP (4357)

The Australian Consumer Law requires the inclusion of the following statement with this warranty:

Our goods come with guarantees that cannot be excluded under the Australian Consumer Law. You are entitled to a replacement or refund for a major failure and for compensation for any other reasonably foreseeable loss or damage. You are also entitled to have the goods repaired or replaced if the goods fail to be of acceptable quality and the failure does not amount to a major failure.



E2447

# Esatto Appliances Exactly what you need



A RESIDENTIA  
GROUP INITIATIVE