

Owner's Manual

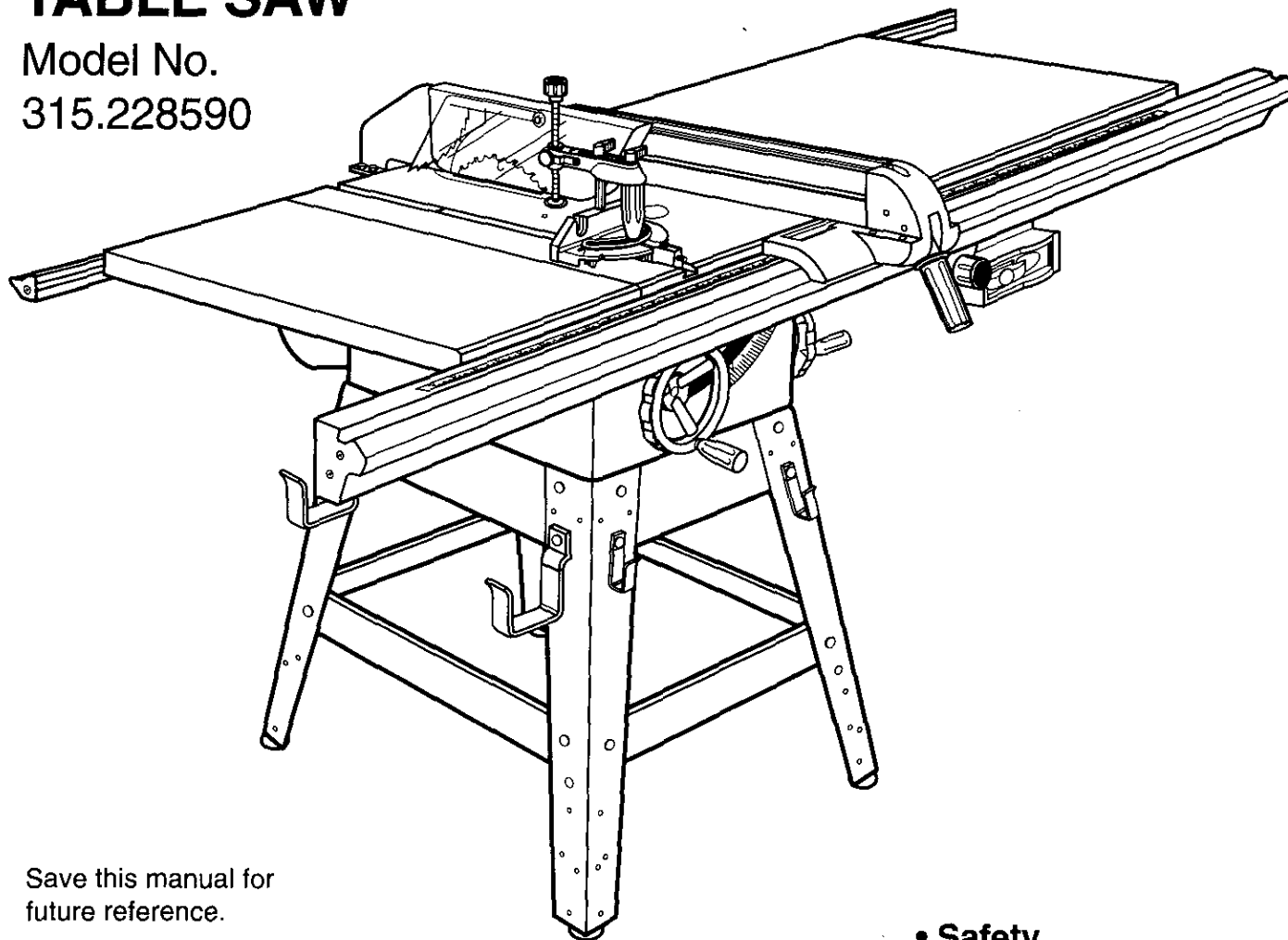

10 in. Stationary TABLE SAW

Model No.
315.228590



Save this manual for
future reference.

CAUTION: Read and follow all
Safety Rules and Operating
Instructions before first use of this
product.

Customer Help Line: 1-800-932-3188

Sears, Roebuck and Co., Hoffman Estates, IL 60179 USA
Visit the Craftsman web page: www.sears.com/craftsman

972000-782
10-00

- Safety
- Features
- Assembly
- Operation
- Maintenance
- Parts List



WARRANTY

FULL ONE YEAR WARRANTY ON CRAFTSMAN TABLE SAW

If this **CRAFTSMAN** Table Saw fails due to a defect in material or workmanship within one year from the date of purchase, Sears will repair it, free of charge.

Contact a Sears Service Center for repair.

If this product is used for commercial or rental purposes, this warranty applies only for 90 days from the date of purchase.

This warranty gives you specific legal rights, and you may also have other rights which vary from state to state.

Sears, Roebuck and Co., Dept. 817WA, Hoffman Estates, IL 60179

INTRODUCTION

Your saw has many features for making cutting operations more pleasant and enjoyable. Safety, performance and dependability have been given top priority in the design of this saw making it easy to maintain and operate.

CAUTION: Carefully read through this entire owner's manual before using your new saw. Pay close attention to the Rules For Safe Operation, and all Safety Alert Symbols, including Danger, Warning and Caution. If you use your saw properly and only for what it is intended, you will enjoy years of safe, reliable service.

Look for this symbol to point out important safety precautions. It means attention!!! Your safety is involved.

WARNING:



The operation of any power tool can result in foreign objects being thrown into your eyes, which can result in severe eye damage. Before beginning power tool operation, always wear safety goggles or safety glasses with side shields and a full face shield when needed. We recommend a Wide Vision Safety Mask for use over eyeglasses or standard safety glasses with side shields, available at Sears Retail Stores.

TABLE OF CONTENTS

■ Warranty and Introduction	2
■ Table Of Contents	2-3
■ Rules For Safe Operation	4-6
■ Electrical	7
■ Glossary and Product Specifications	8
■ Unpacking and Accessories	9
■ Loose Parts List	10-11
■ Small Parts List	11-13
■ Tools Needed	14
■ Labels	15-16
■ Features	17-18
■ Assembly	19-33
Installing Handwheels on Table Saw Base	19
Assembling Steel Leg Stand	19-20

TABLE OF CONTENTS (CONT.)

Mounting the Leg Stand on the Table Saw Base	20
Table Extensions	21
Assembling Cast Iron Table Extension	21
Aligning Cast Iron Table Extension	21
Installing the Rear Rail	22
Installing the Front Rail	23
Assembling MDF Table Extension	23-24
Assembling Storage Hangers	24
Installing the Micro-Adjust	24-25
Aligning Rip Fence and Rails	25
Mounting the Motor and Switch	26
Installing the Belt and Belt Guard	27
Installing the Blade Guard	28
Checking the Throat Plate	29
Aligning the Riving Knife with the Blade	29
Checking Heeling (Paralleling) of the Sawblade to Miter Gage Groove	30
Checking Rip Fence and Blade Alignment	31
Changing the Motor Voltage	32
Assembling the Hold Down Clamp on the Miter Gage	33
■ Adjustments	34-37
Replacing the Blade	34
Heeling (Paralleling) the Sawblade to Miter Gage Groove	35
Setting the Bevel Stops and Indicator	36
Adjusting the Miter Gage	37
Removing / Replacing the Throat Plate	37
■ Basic Operation of the Table Saw	38-47
Causes of Kickback	38
Avoiding Kickback	38
Cutting Aids	38
Resetting Thermal Overload Protector	39
Causes of Overload	39
Types of Cuts	40
Making a Cross Cut	41-42
Making a Rip Cut	42
Making a Miter Cut	43
Making a Bevel Cross Cut	43-44
Making a Bevel Rip Cut	44
Making a Compound (Bevel) Miter Cut	45
Making a Large Panel Cut	46
Making a Non-Through Cut	47
Making a Dado Cut	47
■ Maintenance	48
■ Lubrication	48
■ Troubleshooting	49-51
■ Exploded View and Repair Parts List	52-69
■ Parts Ordering / Service	back page



RULES FOR SAFE OPERATION

The purpose of safety symbols is to attract your attention to possible dangers. The safety symbols, and the explanations with them, deserve your careful attention and understanding. The safety warnings do not by themselves eliminate any danger. The instructions or warnings they give are not substitutes for proper accident prevention measures.

SYMBOL MEANING



SAFETY ALERT SYMBOL

Indicates danger, warning, or caution. May be used in conjunction with other symbols or pictographs.



DANGER: Failure to obey a safety warning will result in serious injury to yourself or to others.

Always follow the safety precautions to reduce the risk of fire, electric shock and personal injury.



WARNING: Failure to obey a safety warning can result in serious injury to yourself or to others.

Always follow the safety precautions to reduce the risk of fire, electric shock and personal injury.



CAUTION: Failure to obey a safety warning may result in property damage or personal injury to yourself or to others. Always follow the safety precautions to reduce the risk of fire, electric shock and personal injury.

Note: Advises you of information or instructions vital to the operation or maintenance of the equipment.

IMPORTANT

Servicing requires extreme care and knowledge of the system and should be performed only by a qualified service technician. For service we suggest you return the tool to your nearest Sears store or repair center. Always use original factory replacement parts when servicing.



WARNING: Do not attempt to operate this tool until you have read thoroughly and understand completely all instructions, safety rules, etc. contained in this manual. Failure to comply can result in accidents involving fire, electrical shock, or serious personal injury. Save the owner's manual and review frequently for continuing safe operation, and instructing others who may use this tool.

READ ALL INSTRUCTIONS

- **KNOW YOUR POWER TOOL.** Read the owner's manual carefully. Learn the saw's applications and limitations as well as the specific potential hazards related to this tool.
- **DO NOT USE IN DANGEROUS ENVIRONMENT.** Do not use power tools near gasoline or other flammable liquids, in damp or wet locations, or expose them to rain. Keep the work area well lit.
- **MAKE WORKSHOP CHILD-PROOF** with padlocks and master switches or by removing starter keys.
- **KEEP CHILDREN AND VISITORS AWAY.** All visitors should wear safety glasses and be kept a safe distance from work area. Do not let visitors contact tool or extension cord while operating.
- **KEEP THE WORK AREA CLEAN.** Cluttered work areas and work benches invite accidents. **DO NOT** leave tools or pieces of wood on the saw while it is in operation.
- **MAINTAIN TOOLS WITH CARE.** Keep tools sharp and clean for better and safer performance. Follow instructions for lubricating and changing accessories.
- **USE THE RIGHT TOOL FOR THE JOB.** Do not force the tool or attachment to do a job it was not designed for. Use it only the way it was intended.
- **DRESS PROPERLY.** Do not wear loose clothing, gloves, neckties, rings, bracelets, or other jewelry. They can get caught and draw you into moving parts. Rubber gloves and nonslip footwear are recommended. Also wear protective hair covering to contain long hair.
- **ALWAYS WEAR SAFETY GLASSES WITH SIDE SHIELDS.** Everyday eyeglasses have only impact-resistant lenses; they are **NOT** safety glasses.
- **NEVER STAND ON TOOL.** Serious injury could occur if the tool is tipped or if the blade is unintentionally contacted.
- **DO NOT OVERREACH.** Keep proper footing and balance at all times.

RULES FOR SAFE OPERATION (Continued)

- **SECURE WORK.** Use clamps or a vise to hold work when practical. It's safer than using your hand and frees both hands to operate tool.
- **USE THE PROPER EXTENSION CORD.** Make sure your extension cord is in good condition. Use only a cord heavy enough to carry the current your product will draw. An undersized cord will cause a drop in line voltage resulting in loss of power and overheating. A wire gage size (A.W.G.) of at least 14 is recommended for an extension cord 25 feet or less in length. If in doubt, use the next heavier gage. The smaller the gage number, the heavier the cord.
- **AVOID ACCIDENTAL STARTING.** Be sure switch is off when plugging in.
- **REMOVE WRENCHES AND ADJUSTING KEYS.** Get in the habit of checking - before turning on tool - that hex keys and adjusting wrenches are removed from tool.
- **CHECK DAMAGED PARTS.** Before using the tool again, check any damaged parts, including guards, for proper operation and performance. Check alignment of moving parts, binding of moving parts, breakage of parts, saw stability, mounting and any other conditions that may affect its operation. A damaged part must be properly repaired or replaced by a qualified service technician at a Sears store or repair center to avoid risk of personal injury.
- **USE ONLY CORRECT BLADES.** Use the right blade size, style and cutting speed for the material and the type of cut. Blade teeth should point down toward the front of the table.
- **USE RECOMMENDED ACCESSORIES.** Using improper accessories may risk injury.
- **USE ONLY SEARS REPLACEMENT PARTS.** All repairs, whether electrical or mechanical, should be made by a qualified service technician at a Sears store or repair center.
- **KEEP GUARDS IN PLACE** and in good working order. This includes the blade guard, riving knife, and anti-kickback pawls.
- **CHECK DIRECTION OF FEED.** Feed work into a blade or cutter against the direction of rotation of the blade or cutter only.
- **DISCONNECT ALL TOOLS.** When not in use, before servicing, or when changing attachments, blades, bits, cutters, etc., all tools should be disconnected from power supply.
- **DO NOT FORCE THE TOOL.** It will do the job better and more safely at the rate for which it was designed.
- **NEVER LEAVE TOOL RUNNING UNATTENDED. TURN THE POWER OFF.** Do not leave tool until it comes to a complete stop.
- **BEFORE MOUNTING, DISCONNECTING OR REMOUNTING THE MOTOR;** unplug the saw and remove the switch key.
- ⚠ **WARNING:** When servicing, use only identical Craftsman replacement parts. Use of any other parts may create a hazard or cause product damage.
- **NEVER USE THIS TOOL IN AN EXPLOSIVE ATMOSPHERE.** Normal sparking of the motor could ignite fumes.
- **MAKE SURE THE WORK AREA HAS AMPLE LIGHTING** to see the work and that no obstructions will interfere with safe operation **BEFORE** performing any work using this tool.
- **DO NOT USE TOOL IF SWITCH DOES NOT TURN IT ON AND OFF.** Have defective switches replaced by a qualified service technician at a Sears store or repair center.
- **GUARD AGAINST ELECTRICAL SHOCK** by preventing body contact with grounded surfaces such as pipes, radiators, ranges, refrigerator enclosures.
- **GROUND ALL TOOLS.** See Electrical page.
- **WEAR A DUST MASK** to keep from inhaling fine particles.
- **PROTECT YOUR HEARING.** Wear hearing protection during extended periods of operation.
- **DO NOT OPERATE THIS TOOL WHILE UNDER THE INFLUENCE OF DRUGS, ALCOHOL, OR ANY MEDICATION.**
- **STAY ALERT AND EXERCISE CONTROL.** Watch what you are doing and use common sense. **Do not operate tool when you are tired. Do not rush.**
- **AVOID AWKWARD OPERATIONS AND HAND POSITIONS** where a sudden slip could cause your hand to move into the blade. **ALWAYS** make sure you have good balance.
- **ALWAYS SUPPORT LARGE WORK PIECES** while cutting to minimize risk of blade pinching and kickback. Saw may slip, walk or slide while cutting large or heavy boards.
- **GUARD AGAINST KICKBACK.** Kickback can occur when the blade stalls, driving the work piece back toward the operator. It can pull your hand into the blade, resulting in serious personal injury. Stay out of the blade path and turn switch off immediately if blade binds or stalls.

RULES FOR SAFE OPERATION (Continued)

- **USE A SUPPORT FOR THE SIDES AND BACK OF THE SAW TABLE** when sawing wide or long workpieces. Use a sturdy “outrigger” support if a table extension is more than 24 inches long and is attached to the saw, to prevent tipping.
- **CUT ONLY WOOD, PLASTIC OR WOOD-LIKE MATERIALS.** Do not cut metal.
- **NEVER** cut more than one piece at a time. **DO NOT STACK** more than one workpiece on the saw table at a time.
- **DO NOT REMOVE THE SAW'S BLADE GUARDS.** Never operate the saw with any guard or cover removed. Make sure all guards are operating properly before each use.
- **NEVER PERFORM ANY OPERATION FREE-HAND.** Always place the workpiece to be cut on the saw table and position it firmly against the fence as a backstop.
- **USE THE RIP FENCE.** Always use a fence or straight edge guide when ripping.
- **BEFORE MAKING A CUT,** be sure all adjustments are secure.
- **BE SURE THE BLADE PATH IS FREE OF NAILS.** Inspect for and remove all nails from lumber before cutting.
- **BE SURE THE BLADE CLEARS THE WORKPIECE.** Never start the saw with the blade touching the workpiece.
- **KEEP HANDS AWAY FROM CUTTING AREA.** Do not reach underneath work or in blade cutting path with your hands and fingers for any reason. Always turn the power off.
- **USE A PUSHBLOCK OR PUSH STICK** for workpieces so small that your fingers go under the blade guard. **NEVER TOUCH BLADE** or other moving parts during use, for any reason.
- ▲ **WARNING:** Blade coasts after being turned off.
- **ALLOW THE MOTOR TO COME UP TO FULL SPEED** before starting a cut to avoid blade binding or stalling.
- **ALWAYS PUSH THE WORKPIECE;** never pull it toward the saw.
- **DO NOT FEED THE MATERIAL TOO QUICKLY.** Do not force the workpiece against the blade.
- **ALWAYS TURN OFF SAW** before disconnecting it, to avoid accidental starting when reconnecting to power supply. **NEVER** leave the table saw unattended while connected to a power source.
- **BEFORE CHANGING THE SETUP, REMOVING COVERS, GUARDS, OR BLADE;** unplug the saw and remove the switch key.
- **KEEP TOOL DRY, CLEAN, AND FREE FROM OIL AND GREASE.** Always use a clean cloth when cleaning. Never use brake fluids, gasoline, petroleum-based products, or any solvents to clean tool.
- **KEEP BLADES CLEAN, SHARP AND WITH SUFFICIENT SET.** Sharp blades minimize stalling and kickback.
- **USE ONLY OUTDOOR EXTENSION CORDS.** Use only extension cords with the marking “Acceptable for use with outdoor appliances; store cords indoors while not in use.” Use extension cords with an electrical rating not less than the saw's rating. Always disconnect the extension cord from the outlet before disconnecting the product from the extension cord.
- **INSPECT TOOL CORDS AND EXTENSION CORDS PERIODICALLY** and, if damaged, have repaired by a qualified service technician at a Sears store or repair center. Stay constantly aware of cord location and keep it well away from the moving blade.
- **DO NOT ABUSE CORD.** Never yank cord to disconnect it from receptacle. Keep cord from heat, oil, and sharp edges.
- **SAVE THESE INSTRUCTIONS.** Refer to them frequently and use to instruct other users. If you loan someone this tool, loan them these instructions also.
- ▲ **WARNING:** Some dust created by power sanding, sawing, grinding, drilling, and other construction activities contains chemicals known to cause cancer, birth defects or other reproductive harm. Some examples of these chemicals are:
 - lead from lead-based paints,
 - crystalline silica from bricks and cement and other masonry products, and
 - arsenic and chromium from chemically-treated lumber.Your risk from these exposures varies, depending on how often you do this type of work. To reduce your exposure to these chemicals: work in a well ventilated area, and work with approved safety equipment, such as those dust masks that are specially designed to filter out microscopic particles.

SAVE THESE INSTRUCTIONS

ELECTRICAL

EXTENSION CORDS

Use only 3-wire extension cords that have 3-prong grounding plugs and 3-pole receptacles that accept the tool's plug. When using a power tool at a considerable distance from the power source, use an extension cord heavy enough to carry the current that the tool will draw. An undersized extension cord will cause a drop in line voltage, resulting in a loss of power and causing the motor to overheat. Use the chart provided below to determine the minimum wire size required in an extension cord. Only round jacketed cords listed by Underwriter's Laboratories (UL) should be used.

Length of Extension Cord	Wire Size (A.W.G.)
Up to 25 feet	14
26-100 feet	12

When working with the tool outdoors, use an extension cord that is designed for outside use. This is indicated by the letters **WA** on the cord's jacket.

Before using an extension cord, inspect it for loose or exposed wires and cut or worn insulation.

⚠ CAUTION: Keep the cord away from the cutting area and position the cord so that it will not be caught on lumber, tools, or other objects during cutting operations.

ELECTRICAL CONNECTION

Your Sears Craftsman Table Saw is powered by a precision built electric motor. It should be connected to a **power supply that is 120 volts, 60 Hz, AC only (normal household current)**. It should be connected to a 240 volt power supply **only if it has been reset according to the instructions** in this manual. The motor has been set at the factory for 120 volts; if it is reconnected to operate at 240 volts, all attachment plugs and any receptacles must be replaced with devices rated for 240 volts. Do not operate this tool on direct current (DC). A substantial voltage drop will cause a loss of power and the motor will overheat. If the saw does not operate when plugged into an outlet, double check the power supply.

SPEED AND WIRING

The no-load speed of your table saw is approximately 3,600 rpm. This speed is not constant and decreases under a load or with lower voltage. For voltage, the wiring in a shop is as important as the motor's horsepower rating. A line intended only for lights cannot properly carry a power tool motor. Wire that is heavy enough for a short distance will be too light for a greater distance. A line that can support one power tool may not be able to support two or three tools.

GROUNDING INSTRUCTIONS

In the event of a malfunction or breakdown, grounding provides a path of least resistance for electric current to reduce the risk of electric shock. This tool is equipped with an electric cord having an equipment-grounding conductor and a grounding plug. The plug must be plugged into a matching outlet that is properly installed and grounded in accordance with all local codes and ordinances.

Do not modify the plug provided. If it will not fit the outlet, have the proper outlet installed by a qualified electrician. Improper connection of the equipment-grounding conductor can result in a risk of electric shock. The conductor with insulation having an outer surface that is green with or without yellow stripes is the equipment-grounding conductor. If repair or replacement of the electric cord or plug is necessary, do not connect the equipment-grounding conductor to a live terminal.

Check with a qualified electrician or service personnel if the grounding instructions are not completely understood, or if in doubt as to whether the tool is properly grounded.

Repair or replace a damaged or worn cord immediately.

This tool is intended for use on a circuit that has an outlet like the one shown in *Figure 1*. It also has a grounding pin like the one shown.

⚠ WARNING: Instructions are given in the Assembly section for changing the motor voltage to 240 volts. Follow them carefully ... **Electrical shock can kill.**

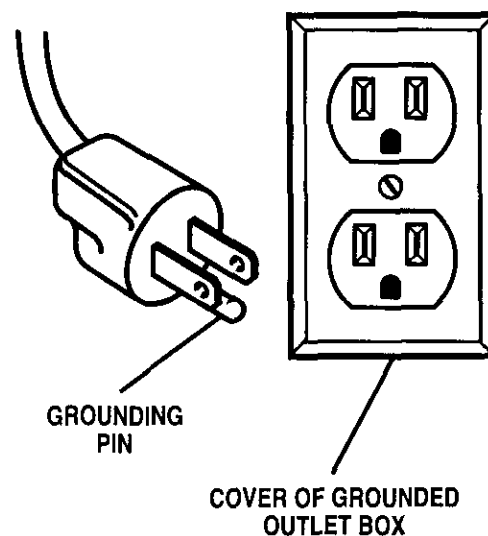

Fig. 1

GLOSSARY OF TERMS FOR WOODWORKING

Anti-Kickback Pawls

Toothed safety devices behind the blade designed to stop a workpiece from being kicked back at the operator during a ripping operation.

Arbor

The shaft on which a blade or cutting tool is mounted.

Bevel Cut

A cutting operation made with the blade at any angle other than 90° to the saw table.

Compound Cut

A cut with both a miter angle and a bevel angle.

Crosscut

A cutting operation made across the grain or the width of the workpiece.

Dado

A non-through cut that gives a square notch or trough; requires a special blade.

Featherboard

A device to help guide workpieces during rip cuts.

Freehand (for table saw)

Dangerous practice of making a cut without using rip or miter fences. See Safety Rules.

Gum

A sticky, sap-based residue from wood products.

Heel

Alignment of the blade.

Kerf

The material removed by the blade in a through cut or the slot produced by the blade in a non-through cut.

Kickback

A hazard that can occur when blade binds or stalls, throwing workpiece back toward operator.

Leading End

The end of the workpiece pushed into the cutting tool first.

Miter Cut

A cutting operation made with the miter gage using any angle other than 0° on the miter gage.

Molding

A non-through cut that gives a varied shape to the workpiece and requires a special blade.

Push Stick

A device used to feed the workpiece through the saw blade during narrow cutting operations. It helps keep the operator's hands well away from the blade.

Rabbet

A notch in the edge of a workpiece.

Resaw

A cutting operation to reduce the thickness of the workpiece in order to make thinner pieces.

Resin

A sticky, sap-based substance.

Rip Cut

A cut made with the the grain of the workpiece.

Sawblade Path

The area directly in line with the blade — over, under, behind, or in front of it. Also, the workpiece area which will be or has been cut by the blade.

Set

The distance that the tip of the saw blade tooth is bent (or set) outward from the face of the blade.

Throw-Back

Saw throwing back a workpiece; similar to kickback.

Through Sawing

Any cutting operation where the blade extends completely through the workpiece.

Trailing End

The workpiece end last cut by the blade in a rip cut.

Workpiece

The item on which the cutting operation is being done. The surfaces of a workpiece are commonly referred to as faces, ends, and edges.

Worktable

The surface on which the workpiece rests while performing a cutting operation.

PRODUCT SPECIFICATIONS

Blade Arbor	5/8 in.	Rating	120 / 240 V, 60 Hz - AC only
Blade Diameter	10 in.	Input	13 /6.5 Amperes
Blade Tilt	0° - 45°	No Load Speed	3,600 RPM
Table Size without table extensions	20 in. x 27 in.	Cutting Capacity with Miter at 0°/Bevel 0°:	3-3/8 in.
Table Size with table extensions	53-1/2 in. x 27 in.	Cutting Capacity with Miter at 0°/Bevel 45°:	2-1/4 in.

UNPACKING

Your new table saw has been designed to give you many years of high quality performance. To insure this goal, proper care and treatment is important. Careful treatment begins with removing all parts from the carton and checking them against the list of loose parts. The long box contains the rails. The large box holds all other parts, which are detailed in the Loose Parts List.

- Separate the saw and all parts from the packing materials and check each against the packing list, especially the small parts that can be hidden in the packing material.

Note: Do not discard the packing materials until you have carefully inspected the saw, identified all parts, and satisfactorily operated your new saw.

WARNING: Never use gasoline, naphtha, or other highly volatile solvents. Do not ever let brake fluids, gasoline, petroleum-based products, or penetrating oils contact plastic parts. Such chemicals can weaken or destroy plastic.

- Remove the wax paper covering on the table. Use any ordinary household type grease and spot remover. Immediately apply a coat of automotive type paste wax to the table and table extensions.

WARNING: To prevent accidental starting that could cause possible serious personal injury, assemble all parts to your saw before connecting it to power supply. Saw should never be connected to power supply when you are assembling parts, making adjustments, installing or removing blades, or when not in use.

WARNING: If any parts are missing, do not operate this tool until the missing parts are replaced. Failure to do so could result in possible serious personal injury.

ACCESSORIES

The following recommended accessories are currently available at Sears Retail Stores.

- Fence Guide System
- Guide Master
- Box Joint & Miter Guide
- Universal Jig
- Taper Jig
- 10 in. Sanding Disc
- 8 in. Sanding Disc
- Elite Dado
- Excalibur Dado
- 7 in. Adj. Dado 36 tip
- 7 in. Adj. Dado 24 tip
- 7 in. Stack Steel Dado
- 7 in. x 9/16 in. Stack Dado
- 7 in. Molding Head Set
- 2 Bit Molding Head Set
- Saw Baskets
- Jointer Clamps
- Specialty Throat Plate
- Accessory Table

WARNING: The use of attachments or accessories not listed might be hazardous.

LOOSE PARTS LIST

The following items are included with your Table Saw.

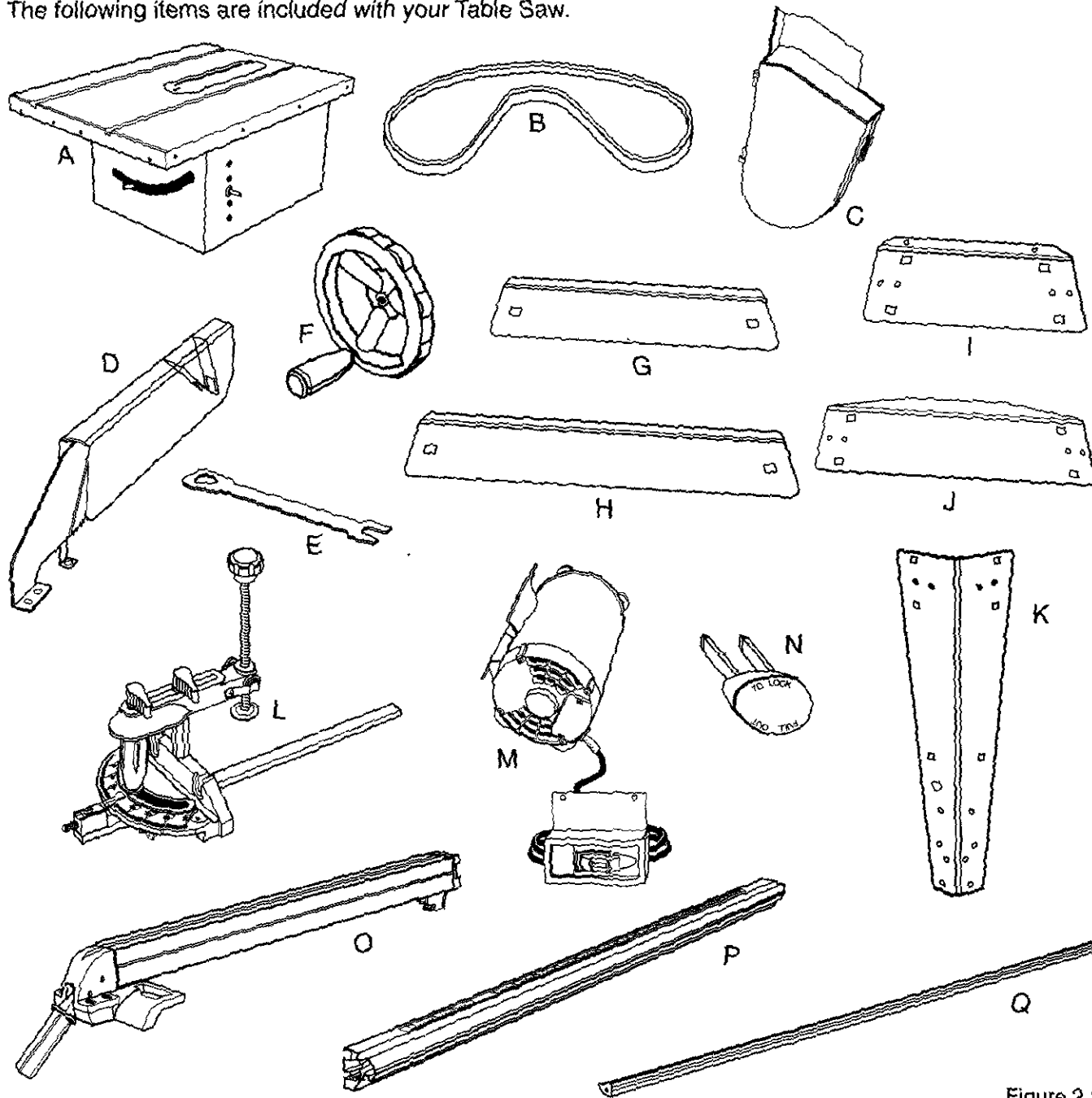

Figure 2 a

A. Table Saw Base	1	H. Leg Brace, lower (long)	2
B. Belt	1	I. Leg Brace, upper (short)	2
C. Belt Guard (Hardware Shown Separately)	1	J. Leg Brace, upper (long)	2
D. Blade Guard Assembly (Hardware Shown Separately)	1	K. Leg	4
E. Wrench	1	L. Miter Gage (some assembly required)	1
F. Handwheel (Hardware Shown Separately)	2	M. Motor and Switch (Hardware Shown Separately) .	1
G. Leg Brace, lower (short)	2	N. Switch Key	1
		O. Rip Fence	1
		P. Rail, Front (Hardware Shown Separately)	1
		Q. Rail, Rear (Hardware Shown Separately)	1

LOOSE PARTS LIST

The following items are included with your Table Saw.

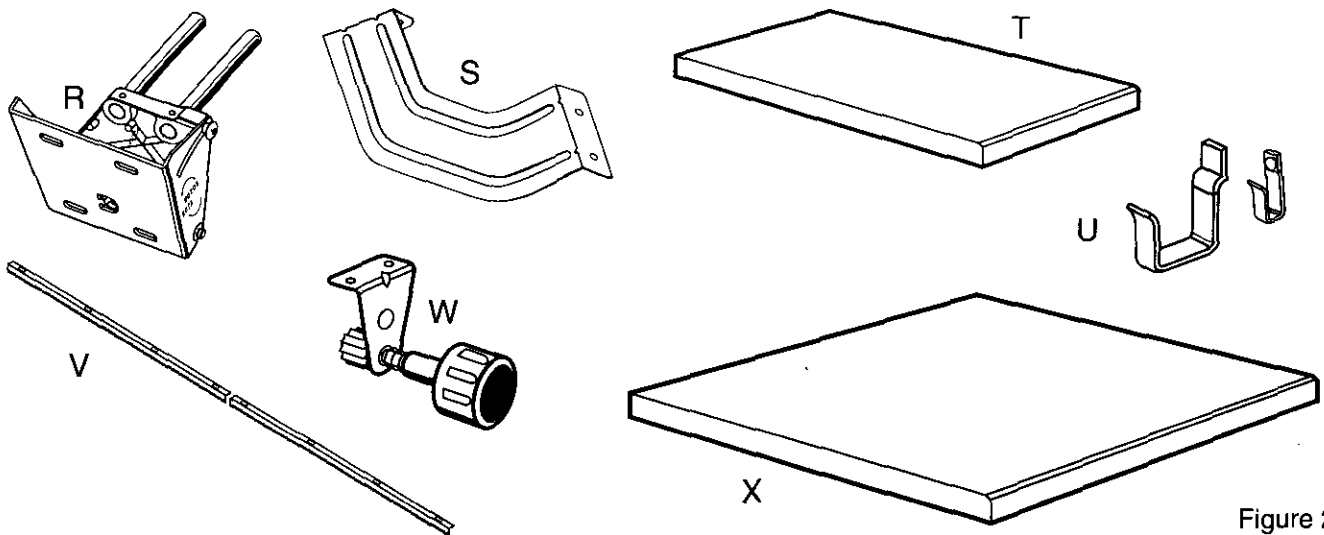

Figure 2 b

R. Motor Mounting Plate (Hardware Shown Separately)	1	X. MDF Table Extension (Hardware Shown Separately)	1
S. Blade Guard Bracket	1	Y. Dust Bag (not shown)	1
T. Table Extension (Hardware Shown Separately) ...	1	Z. Owner's Manual (not shown)	1
U. Hangers (Hardware Shown Separately)	4	AA. Hardware for Leg Stand, Leveling Feet, and Mounting Saw Base (Shown Separately)	1
V. Micro-Adjust Gear Rack (Hardware Shown Separately)	1	BB. Hardware for Blade Guard Bracket and Blade Guard Assembly (Shown Separately)	1
W. Micro-Adjust Knob (Hardware Shown Separately)	1		

SMALL PARTS LIST

Check all loose parts from the box with the list on pages 10 - 13. Small items such as fasteners and end caps are shown in figures 2 c, 2 d, and 2 e. Follow the instructions in the *Assembly* section to assemble your new saw.





C. Hardware for Belt Guard	1	M. Hardware for Mounting Motor and Switch Box	
hex nut (#10-24)	4	Hardware for Mounting Motor	1
flat washer (#10)	4	hex bolt (5/16-18 x 1 in.)	4
		flat washer (5/16 in.)	8
F. Hardware for Handwheel	2	lock washer (5/16 in.)	4
screw (#10-24 x 1/2 in.)	2	hex nut (5/16-18)	4
lock washer (#10)	2		
		Hardware for Mounting Switch Assembly	
		square head nut (1/4-20)	2
		screw (1/4-20 x 3/8 in.)	2
			

Figure 2 c

SMALL PARTS LIST

Check all loose parts from the box with the list on pages 10 - 13. Small items such as fasteners and end caps are shown in figures 2 c, 2 d, and 2 e. Follow the instructions in the Assembly section to assemble your new saw.

- P. Hardware for Front Rail and MDF**
- Table Extension 1
 - square head bolt (5/16-18 x 3/4 in.) 7
 - end cap for front rail 2
 - screw (#8-32 x 1/2 in.) 4
 - hex nut (5/16-18) 7
 - flat washer (5/16 in.) 7



- Q. Hardware For Rear Rail and MDF**
- Table Extension 1
 - square head bolt (5/16-18 x 3/4 in.) 7
 - flat washer (5/16 in.) 7
 - hex nut (5/16-18) 7
 - end cap for rear rail 2
 - screw (#8-32 x 1/2 in.) 2

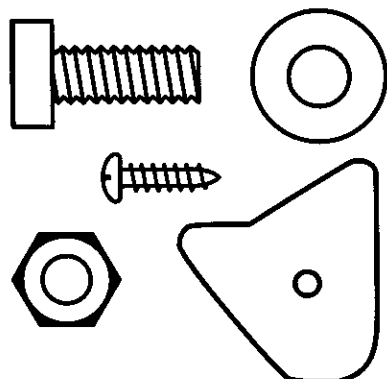

- R. Hardware for Motor Mounting Plate** 1
- hex bolt (5/16-18 x 3/4 in.) 2

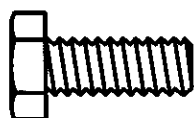

- T. Hardware for Cast Iron Table Extension** 1
- hex bolt (5/16-18 x 1 in.) 4
 - flat washer (5/16 in.) 8
 - hex nut (5/16-18) 4



- U. Hardware for Hangers**
- carriage bolts (5/16-18 x 3/4 in.) 4



- V. Hardware for Micro-Adjust Gear Rack**
- square nut (1/4-20) 8
 - screw (1/4-20 x 3/8 in.) 8



- W. Hardware for Micro-Adjust Knob**
- screw (1/4-20 x 3/8 in.) 2



Fig. 2 d

SMALL PARTS LIST

Check all loose parts from the box with the list on pages 10 - 13. Small items such as fasteners and end caps are shown in figures 2 c, 2 d, and 2 e. Follow the instructions in the *Assembly* section to assemble your new saw.

AA. Hardware for Leg Stand, Leveling Feet, and Mounting Saw Base

Hardware for Leg Stand	1
carriage bolt (5/16-18 x 3/4 in.)	24
flat washer (5/16 in.)	24
hex nut (5/16-18)	24

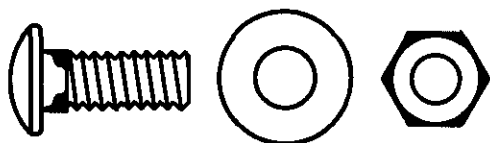

Hardware for Leveling Feet	1
leveling foot	4
flat washer (5/16 in.)	8
hex nut (5/16-18)	8

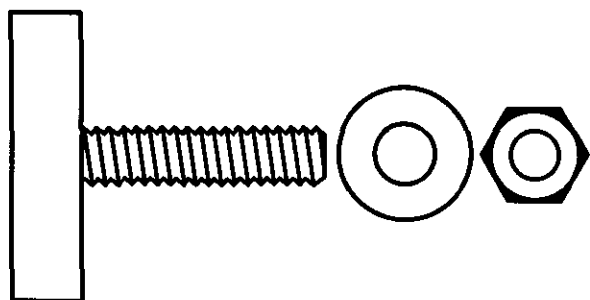

Hardware for Mounting Saw Base	1
hex bolt (5/16-18 x 3/4 in.)	4
flat washer (5/16 in.)	8
hex nut (5/16-18)	4



BB. Hardware for Blade Guard Bracket and Blade Guard Assembly

Blade Guard Bracket	1
hex bolt (5/16-18 x 1/2 in.)	2
lock washer (5/16 in.)	2



Blade Guard Assembly	1
socket head cap screw (1/4-20 x 3/8 in.)	3
flat washer (1/4 in.)	3



Fig. 2 e

TOOLS NEEDED

The following tools are needed for assembly and alignment. **Note:** The five hex keys listed below have been provided with your saw. The remaining tools are typical shop tools and are not included with your saw.



SMALL / MEDIUM
PHILLIPS SCREWDRIVER



NUT DRIVER
8 mm, 10 mm, and 12 mm

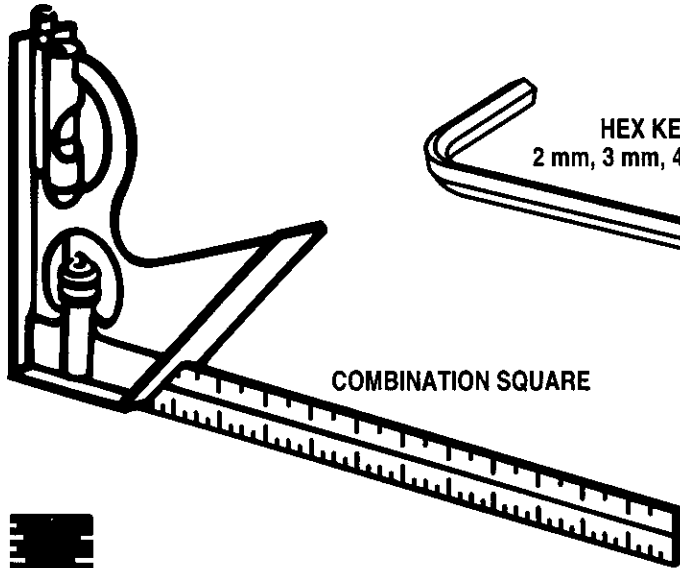

COMBINATION SQUARE

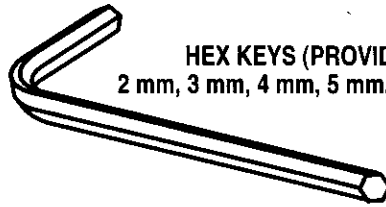

HEX KEYS (PROVIDED)
2 mm, 3 mm, 4 mm, 5 mm, and 6 mm

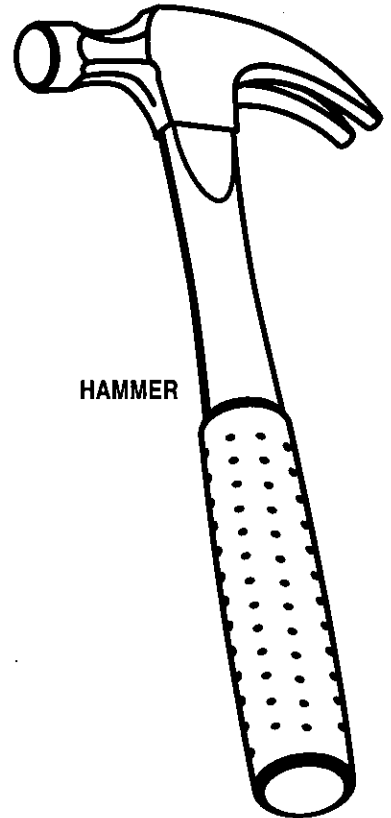

HAMMER

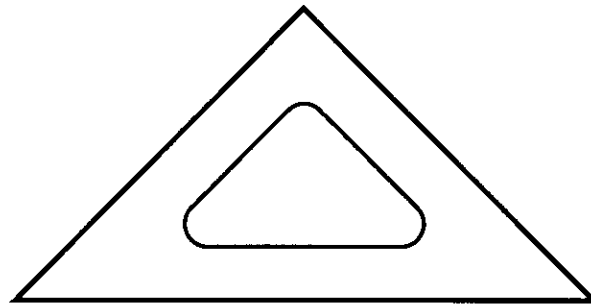

45° TRIANGLE

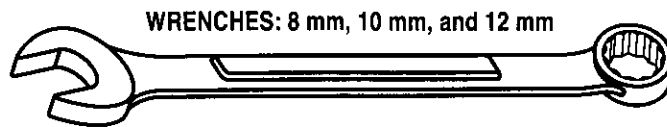

WRENCHES: 8 mm, 10 mm, and 12 mm

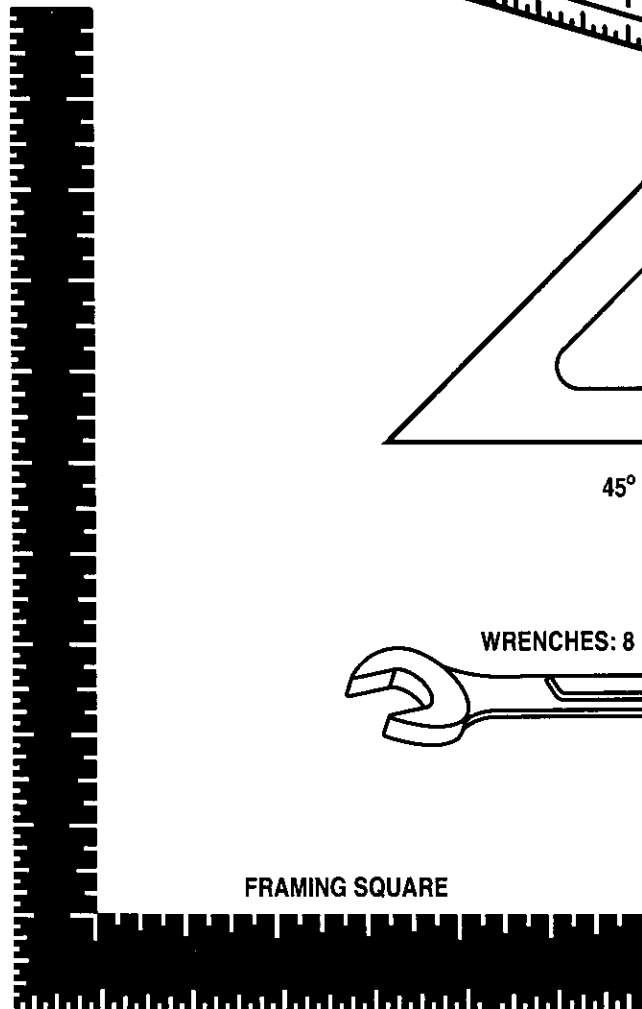

FRAMING SQUARE

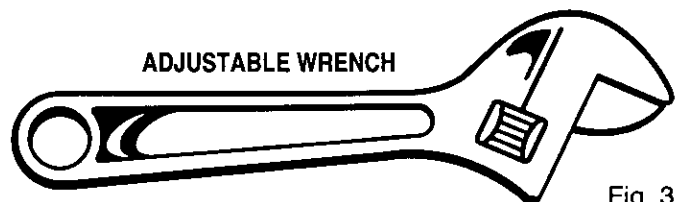

ADJUSTABLE WRENCH

Fig. 3

LABELS

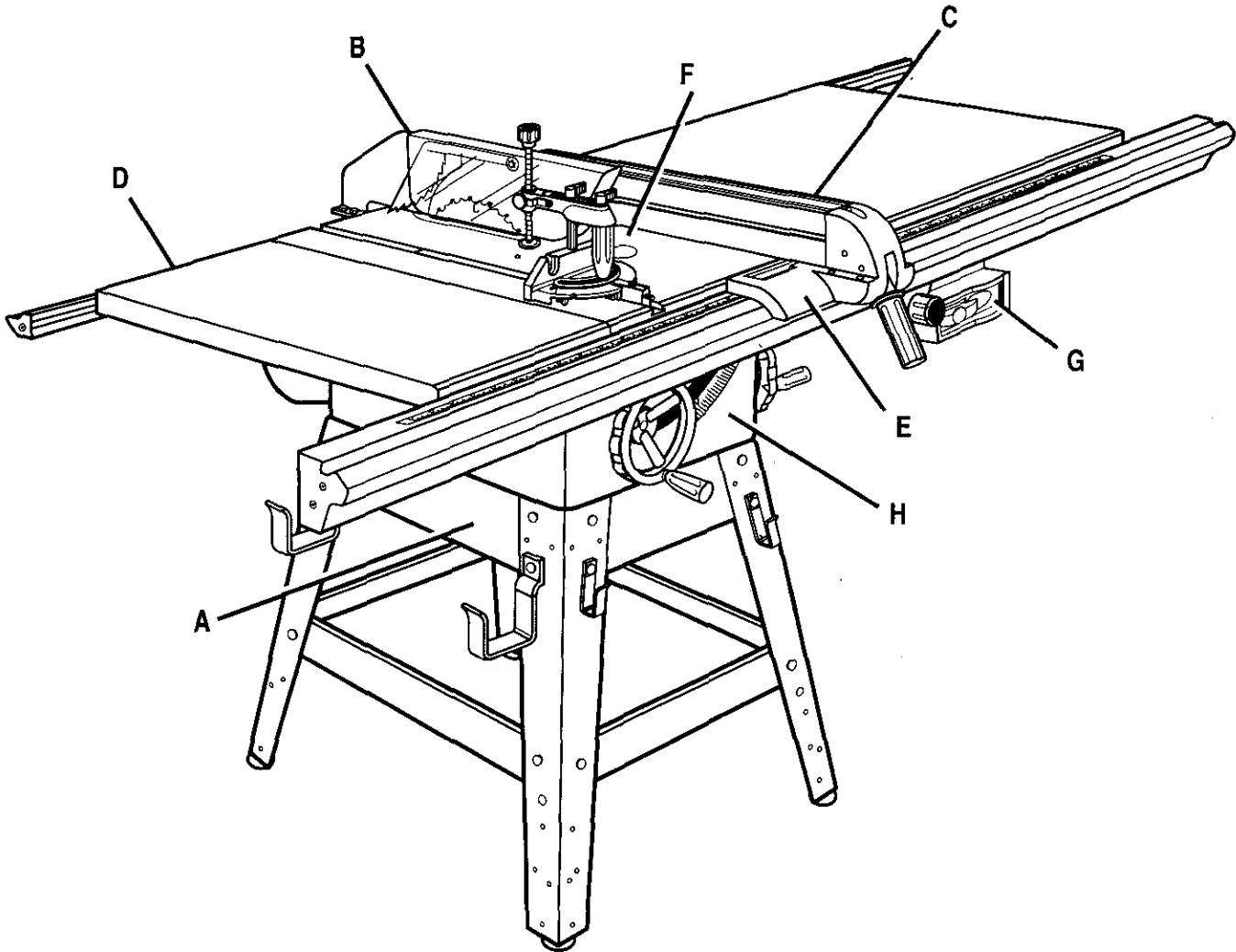

A

10 inch Table Saw

3600 R.P.M. 120/240 VOLTS 60 Hz AC ONLY 13 A / 6.5 A

WARNING

WHEN SERVICING, USE ONLY IDENTICAL CRAFTSMAN REPLACEMENT PARTS.

LR63420



STATIONARY TOOL

MODEL 315.228590 SER. NO.
MADE IN TAIWAN
SEARS, ROEBUCK AND CO.

Customer Help Line 1-800-932-3188

B

WARNING

- Raised Guard Can Drop on Spinning Blade and Break.
- To reduce The Risk of Injury, Guard Must be in Place During Use.
- Align and Tighten Riving Knife Fasteners Before Use

Fig. 4 a

15

CRAFTSMAN® TABLE SAW 315.228590

LABELS

⚠ WARNING

When Mounting an Auxiliary Fence Face, Position Mounting Hardware Beyond Arrow at Right and Left as Indicated.
Keep Fasteners Away From Blade.

C

D

E

Do Not Lift Saw With Rails or Extension Tables.

⚠ WARNING

Debris on rail can misalign the rip fence. Workpiece could bind or suddenly kick back. You could be hit or cut. Clean debris off fence rail before positioning fence.

F

⚠ WARNING

- Attach Blade Guard Assembly Before Operating this Saw
- Read Owner's Manual

G

← **PULL ON** |

| **PUSH OFF** →

H

Turn Clockwise to Raise Blade.
Counterclockwise to Lower Blade.



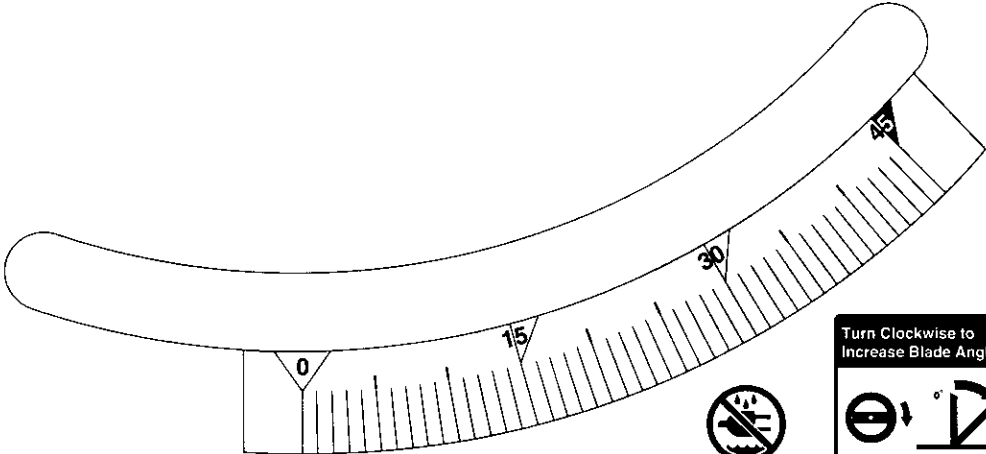

Turn Clockwise to Increase Blade Angle.



CRAFTSMAN®

P R O F E S S I O N A L

⚠ WARNING

- Read manual before using saw.
- Wear safety goggles that meet ANSI Z87.1 standards.
- Do not reach around or over saw blade.
- Keep blade guard down and in place for through cuts.
- Do not make freehand cuts. Keep hands out of path of saw blade.
- When ripping, use push stick when fence is set 2 inches or less from blade.
- Know how to reduce the risk of kickback. See instructions for ripping.
- When ripping, use push block and auxiliary fence when fence is set between 1/2 and 2 inches from blade.
- Do not make rip cuts narrower than 1/2 inch.
- Turn power off and wait for blade to stop before adjusting or servicing.

Fig. 4 b



FEATURES

KNOW YOUR TABLE SAW

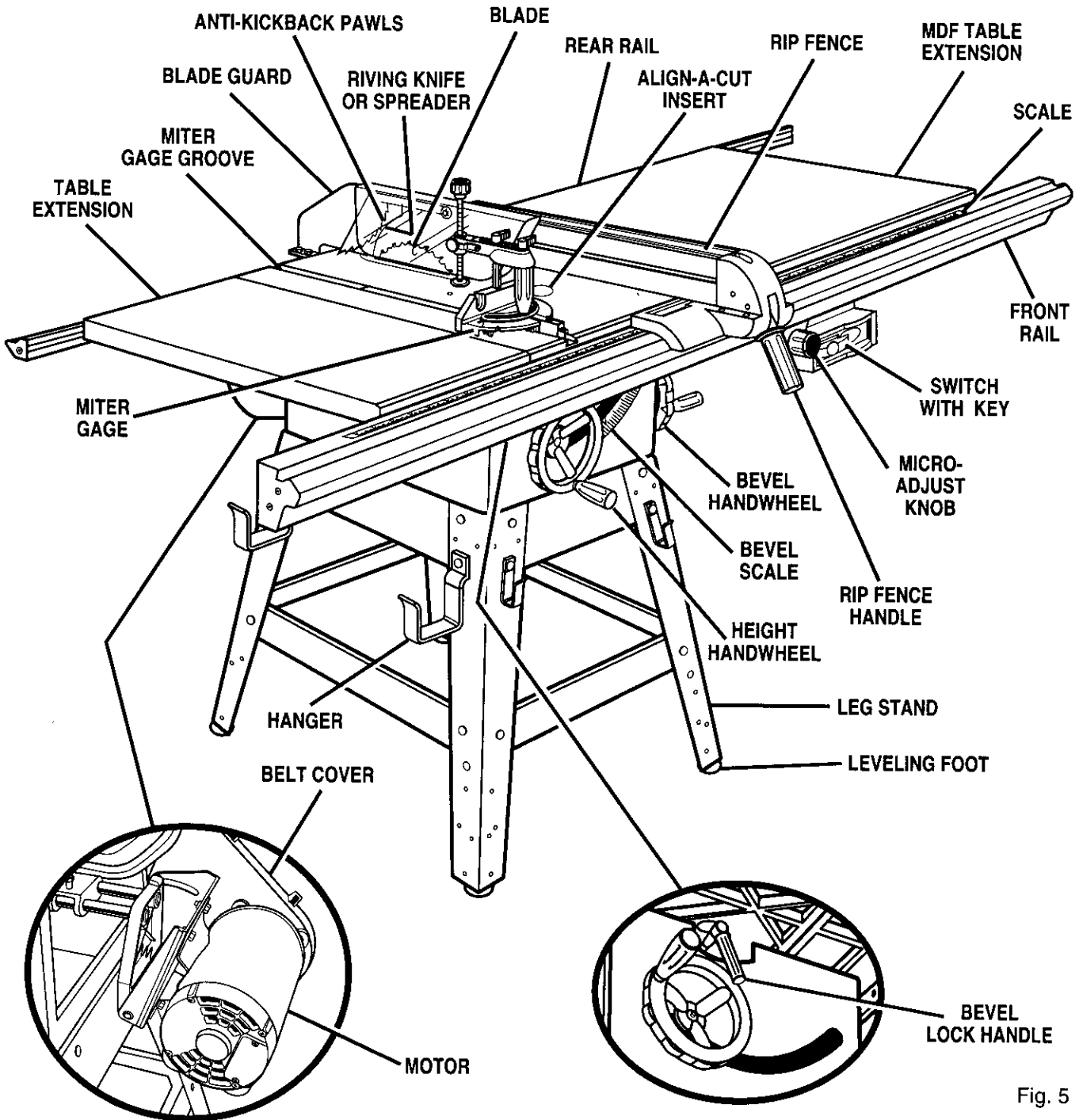

Fig. 5

OVERVIEW

The upper portion of the blade projects up through the table, surrounded by an insert called the throat plate. The height of the blade is set with a handwheel on the front of the cabinet. To accommodate wide panels, the tabletop has extensions on each side. Detailed instructions are provided in the *Operation* section of this manual for the basic cuts: cross cuts, miter cuts, bevel cuts, and compound cuts.

For cuts with the blade straight up and cutting across the grain (cross cuts or miter cuts), use the miter gage to set the angle and push the wood into the blade. To cut with the blade straight up, along the grain of the wood (rip cuts), use the rip fence to guide the wood. Push smaller pieces with a pushblock or pushstick.

To tilt the blade for a bevel cut, use the bevel handwheel on the side of the cabinet. A bevel scale on the front of the cabinet shows the blade angle.

FEATURES

Inside the cabinet, adjustable positive stops control the degree of tilt.

Use the miter gage with a bevel cross cut (compound cut) and the rip fence with a bevel rip cut. Other cuts require special attachments, which have detailed

instructions to reduce risk of injury and ensure the best performance from your new saw.

Before attempting to use your saw, familiarize yourself with all operating features and safety requirements of your Sears Craftsman table saw. The saw's features are described below.

ALIGN-A-CUT INSERT - A plastic insert on which marks may be made to indicate the location of the sawcut on the workpiece.

ANTI-KICKBACK PAWLS - Kickback is a hazard in which the workpiece is thrown back toward the operator. The toothed pawls are designed to snag the workpiece to prevent or reduce injury should kickback occur.

BEVEL HANDWHEEL - This handwheel, on the right side of the cabinet, tilts the blade for a bevel cut.

BEVEL SCALE - The easy-to-read scale on the front of the workstand shows the exact blade angle.

BLADE - This saw is provided with a Craftsman 40 tooth, 10 in. carbide tipped blade. The blade is adjusted with bevel and height handwheels on the cabinet. Bevel angles are locked with a handle below the front rail.

 **WARNING:** Be sure to use only blades rated for at least 5,000 rpm and recommended for use on this saw. Check with your nearest Sears retail store.

BLADE COVER - The internal cover contains sawdust so it can be directed into the sawdust bag.

BLADE GUARD - Always keep the guard down over the blade for through-sawing cuts.

BEVEL LOCK HANDLE - This handle, placed just under the worktable surface on the front of the cabinet, locks the angle setting of the blade. Be sure the handle is hanging straight down before tilting the blade. If it is not straight down, it may jam and bend the locking bolt.

DUAL VOLTAGE - Your table saw can be set up to operate at either 120 or 240 volts. Use extreme caution when changing the voltage.

DUST BAG - Saw dust can be directed into this detachable bag or into a wet/dry vacuum.

HEIGHT HANDWHEEL - Use this handwheel to lower and raise the blade for adjustments or replacement. It is located on the front of the cabinet.

MICRO-ADJUST INDEX - A rip fence gear and track that provides precise indexing.

MITER GAGE - This gage aligns the wood for a crosscut. The easy-to-read indicator shows the exact angle for a miter cut, with positive stops at 90° and 45°.

MITER GAGE GROOVES - The miter gage rides in these grooves on either side of the blade.

MITER GAGE HOLD-DOWN - A clamp assembly that fits onto the miter gage to provide additional stability.

MITER GAGE KNOB - Located on the miter gage, this knob locks in the cutting angle after selection.

MOTOR (13/6.5 AMP) - The powerful induction motor is 3HP, with capacitor start and V-belt drive, and is housed in a sturdy steel base.

OVERLOAD PROTECTOR - This device switches off the saw if it overheats. See the *Operation* section.

RAILS - Front and rear rails provide support for large workpieces and the rip fence.

RIP FENCE - A sturdy metal fence guides the workpiece and is secured with the rip fence handle. Grooves run along the top and sides of the rip fence for use with optional clamps and accessories.

MICRO-ADJUST KNOB - The micro-adjust knob on the front of the rip fence makes fine adjustments to the desired measurement for precise cutting. Push in the knob and turn to position the rip fence.

RIP FENCE HANDLE - The handle on the front of the rip fence releases the rip fence or locks it in place.

RIVING KNIFE OR SPREADER - Located directly behind the blade, it keeps cut edges from binding and supports the blade guard.

SCALE - Found on the front rail, the easy-to-read scale provides precise measurements in rip cuts.

SWITCH WITH KEY - Your table saw has an easy access power switch located below the front rail. The yellow switch key must be removed from the hardware bag and inserted into the switch before saw can be operated. To lock the switch in the **OFF** position, remove the switch key from the switch. Place the key in a location that is inaccessible to children and others not qualified to use the tool.

TABLE EXTENSIONS - Two removable table extensions provide support for larger workpieces. One is a cast iron table extension, 12 in. by 27 in. The other is a larger, mdf table extension, 21-1/4 in. by 27 in.

ASSEMBLY

Assembly is best done in the area where the saw will be used. When you remove the table saw base, loose parts, and hardware from the packing materials, check all items with the loose parts list and drawing. If you are unsure about the description of any part, refer to the drawing. If any parts are missing, delay assembling until you have obtained the missing part(s).

INSTALLING HANDWHEELS ON SAW BASE

See Figure 6.

- Each handwheel bag contains a metal handwheel, a screw (#10-24 x 1/2 in.), and a lock washer (#10).
- Align the handwheels to the shaft ends that extend from the front and right side of the table saw base. Match the flat spots on the shaft and inside the handwheel. Insert a screw and a lock washer in the handwheel center and tighten with a 4 mm hex key.

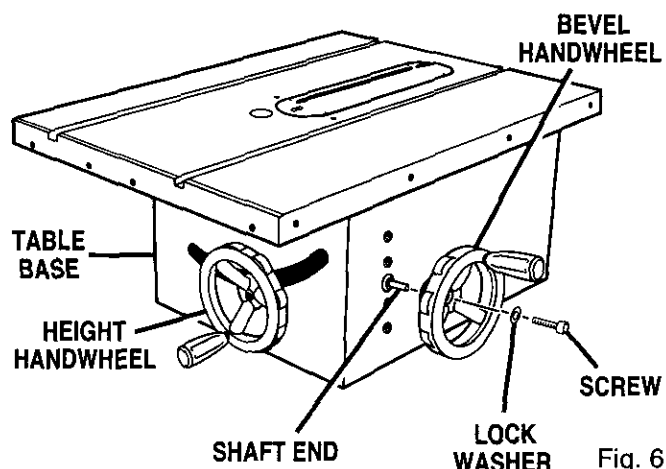

Note: Prior to assembly; clean the protective coating from the top, sides, and ends of the table top on your saw. Also clean protective coating from the cast iron extension table.

Note: If you mount the saw base on a bench instead of the legs, go to Table Extensions, page 21. The bench surface must have an opening for sawdust to fall through, as large as the opening in the bottom of the saw base. A height of 36 in. from the top of the saw table to the floor is recommended.

ASSEMBLING STEEL LEG STAND

See Figures 7 and 8.

- Take the following hardware from the leg stand hardware bag:

- 24 carriage bolts (5/16-18 x 3/4 in.)
- 4 leveling feet
- 32 flat washers (5/16 in.)
- 32 hex nuts (5/16-18)

Note: Remaining hardware from this bag is used for mounting leg stand on the table saw base.

- Take 4 legs and 8 braces from loose parts.
- Place a short upper brace inside two of the legs, with the legs wide end up. (Upper braces have two large holes in each end.) Make sure the two posts on the leg align with the small holes on the brace.

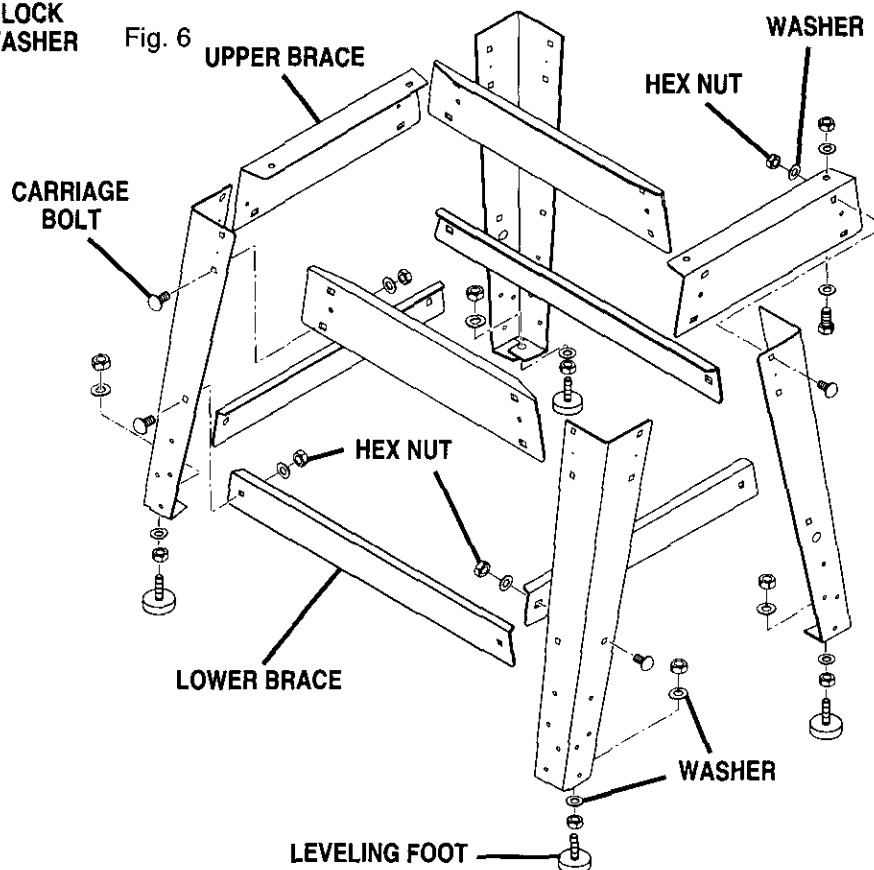

Fig. 7



ASSEMBLY

- Align the two large holes on the brace and the legs. Insert the carriage bolts. Add flat washers and hex nuts and hand tighten. Repeat for the other short upper brace. These are the front and back sets.
- For the side sets, install a long upper brace on two legs. Add hardware and finger tighten. Repeat for the other long upper brace.
- Use the same steps to install the lower braces. Tighten all hex nuts with a 12 mm wrench.
- Place a hex nut and flat washer on each leveling foot. Install the leveling feet from the bottom of each leg with the bolts pointing up. Cap with the remaining flat washers and hex nuts but do not tighten.
- Move the leg set to desired location. Adjust the leveling feet with a 12 mm wrench, then tighten the top hex nut.

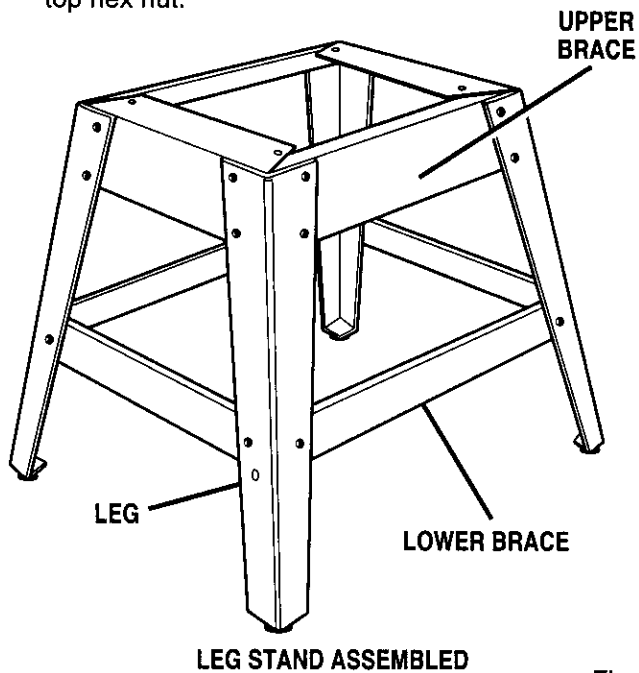

Fig. 8

MOUNTING THE LEG STAND ON THE TABLE SAW BASE

See Figure 9.

- Take the following from a small hardware bag:
 - 4 hex bolts (5/16-18 x 3/4 in.)
 - 4 hex nuts (5/16-18)
 - 8 flat washers (5/16 in.)

Note: This hardware was in the bag with hardware for assembling the leg stand and leveling feet.

- Place the saw table upside down on a smooth surface, such as cardboard, on the floor.

WARNING: Do not lift the saw without help. The saw base weighs approximately 95 lbs. Hold it close to your body. Keep your knees bent and lift with your legs, not your back. Ignoring these precautions can result in back injury.

- Place the leg stand on the table saw base. Align the holes in the table with the holes in the end braces. Make sure the Craftsman label faces the front of the saw which has the height handwheel.
- Place a flat washer on a bolt and insert through hole. Add a flat washer and a hex nut. Hand tighten.
- Repeat for three remaining holes. Tighten all hardware with a 12 mm wrench. You may find it helpful to use one wrench to hold the head of the bolt and one to tighten the hex nut. Leave the saw upside down to add the cast iron extension.

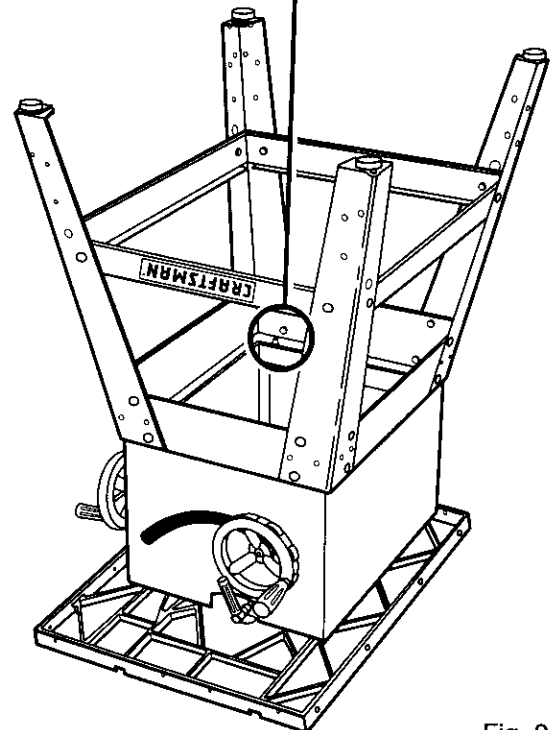
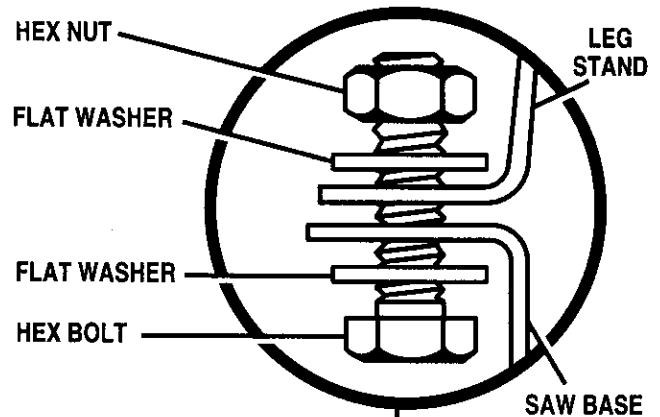

Fig. 9

ASSEMBLY

TABLE EXTENSIONS

Two different table extensions have been supplied with your saw; one is made of cast iron and the other made of MDF material. The cast iron table extension attaches to the saw table. It must be assembled first. The MDF table is assembled after assembly of the front and rear rails. It attaches to the front and rear rails on the opposite side of the saw table.

The cast iron table should be assembled to the left side of the saw table when viewing from normal operating position. The MDF table extension should be assembled to the right side of the saw table when viewing from normal operating position.

ASSEMBLING CAST IRON TABLE EXTENSION

See Figure 10.

- Locate the cast iron table extension and the small hardware bag with the following:

- 4 hex bolts (5/16-18 x 1 in.)
- 4 hex nuts (5/16-18)
- 8 flat washers (5/16 in.)

⚠ WARNING: The table extensions not only provide a better cut on the workpiece but help protect you. Serious injury can result from workpiece binding or kickback due to twisted rails or a misaligned rip fence.

- With the saw upside down, align cast iron table extension with saw table. Put a flat washer on each bolt. Attach the table extension to the saw table by inserting the bolts from the direction of the table.
- Slip the remaining flat washers and hex nuts on the bolts. Lightly tighten them with a 12 mm wrench.

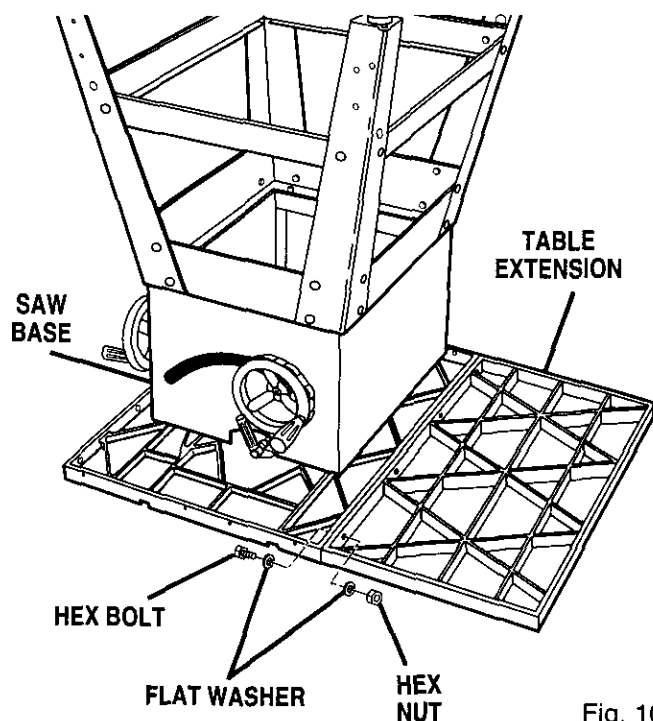

Fig. 10

- Get help to stand the saw assembly upright using the center saw table. Do not grasp the saw by the table extension.

⚠ WARNING: The saw is very heavy. Do not lift the saw table without help. Keep your knees bent and lift with your legs, not your back. Ignoring these precautions can result in back injury.

ALIGNING CAST IRON TABLE EXTENSION

See Figure 11.

A good alignment allows the rails to slide on easily.

- Stand at the front of the saw and line up the front edges of the table and extension.
- To align extension without damaging the table saw, put a block of wood at the front of the table where the extension meets the table, and tap the block with a hammer. Check and repeat until the front edges are even.
- Lift extension slightly until it is higher than the table (if necessary, place a block of wood below and tap upward). Center the block of wood over the front and rear edges and tap until both are even (flush) with saw table. Recheck the front alignment. If it is even, tighten the screws with a 12 mm wrench.

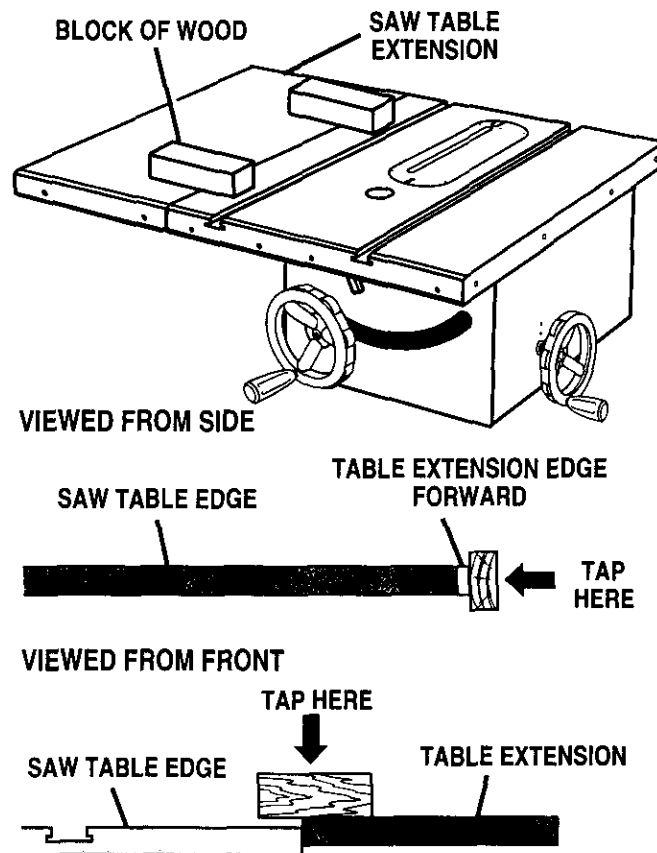

Fig. 11

ASSEMBLY

INSTALLING THE REAR RAIL

See Figures 12, 13, and 14.

⚠ WARNING: Front and rear rails must be carefully aligned to reduce the risk of kickback, which can cause serious injury.

■ From the carton, remove the rear rail and the following hardware:

5 square head bolts (5/16-18 x 3/4 in.)

5 hex nuts (5/16-18)

5 flat washers (5/16 in.)

Right and left end caps for rear rail

2 screws (#8-32 x 1/2 in.) for end caps

Note: Remaining hardware from this hardware bag is used for installing the front rail, MDF table extension, and end caps.

■ At the back of the table, put the square head bolts in the holes in the edge of the table and cast iron extension so the bolt heads extend outward 1/2 in.

■ Under the table, loosely attach the flat washers and hex nuts onto bolts. Slide the slot on the rear rail over the bolts. Adjust each bolt to fit the rail closely to the table.

■ Position rail so that the left hand edge extends 5 in. beyond the table extension.

■ Push the rail against table and tighten each hex nut with a 12 mm wrench. If the rail jams or does not slide easily over the bolts, re-align the table extension.

Note: Make sure there are no gaps between the rail and edge of table or extension.

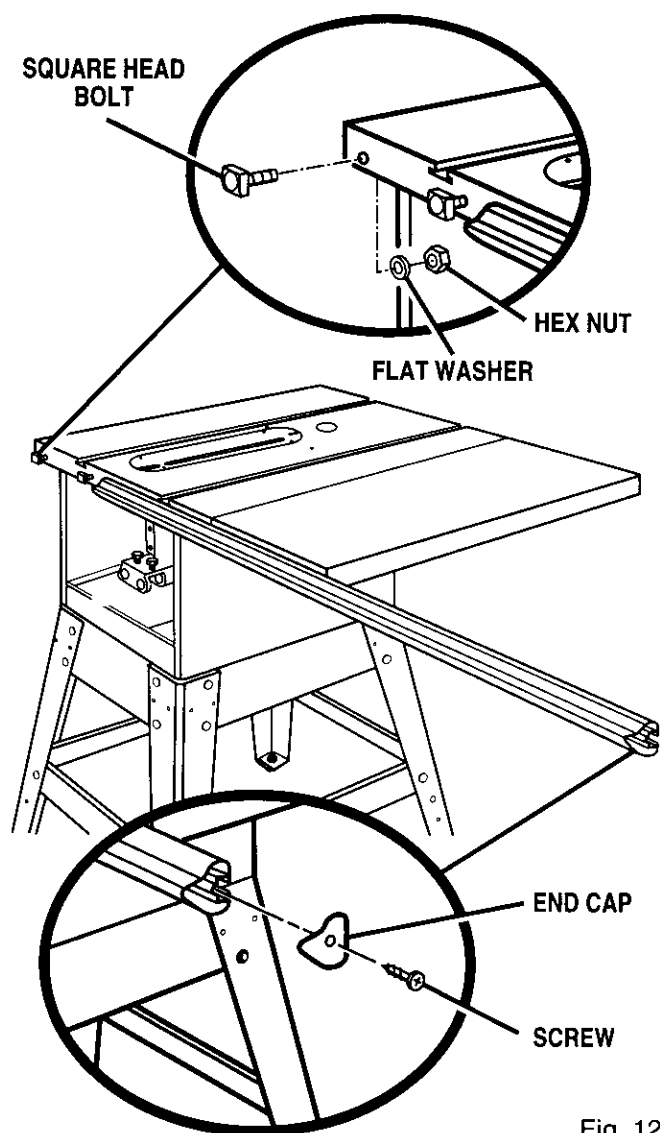

Fig. 12

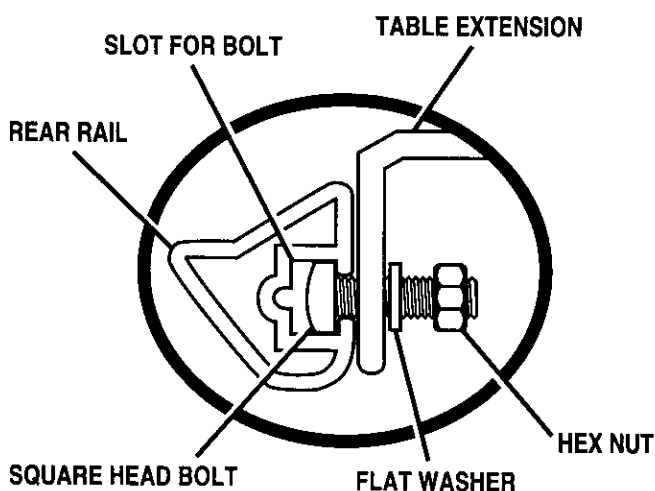

Fig. 13

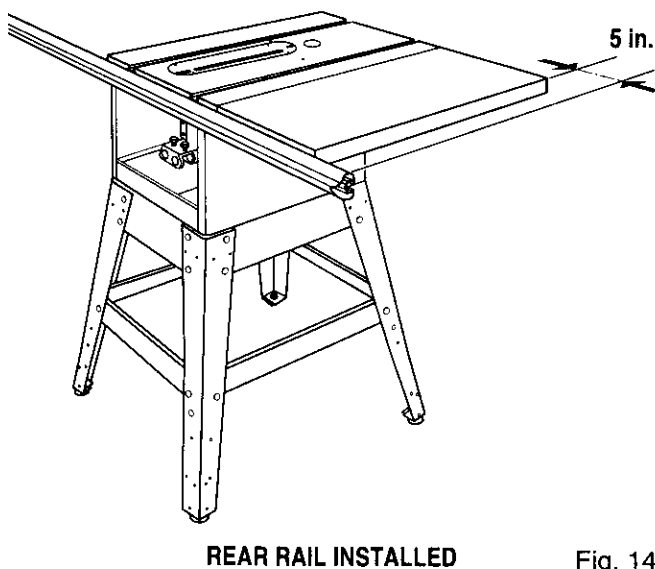

Fig. 14

ASSEMBLY

INSTALLING THE FRONT RAIL

See Figures 15, 16, and 17.

- Locate the front rail, the switch assembly, and the following hardware:
 - 5 square head bolts (5/16-18 x 3/4 in.)
 - 5 flat washers (5/16 in.)
 - 5 hex nuts (5/16-18)
 - Right and left end caps for front rail
 - 4 screws (#8-32 x 1/2 in.) for end caps
- Set aside the end caps and four screws until the MDF table extension and switch have been installed.
- Insert the five square head bolts into the table and extension, so the bolt heads extend out 1/2 in.
- Loosely attach a flat washer and a hex nut to each bolt. See Figure 15.
- The back of the rail has two slots. See Figure 16. Slide the upper slot over the bolts. (Bottom slot is for switch.)
- Align the rail left to right - Match the 6-7/8 in. mark on the right scale to the right edge of the saw base (main table). See Figure 17.
- Snug the rail against table. Finger-tighten each nut on the table and extension.

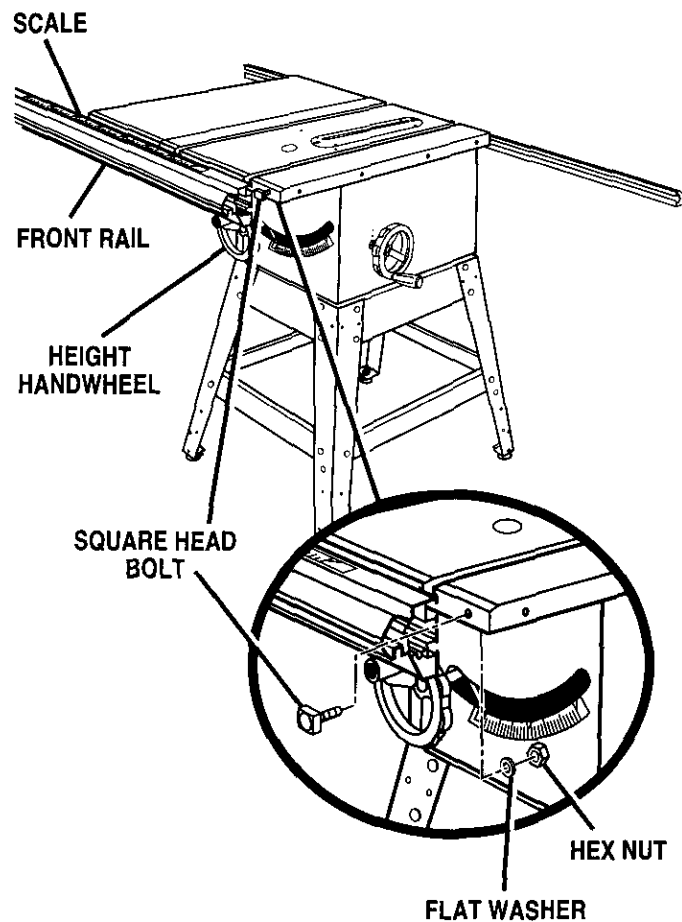

Fig. 15

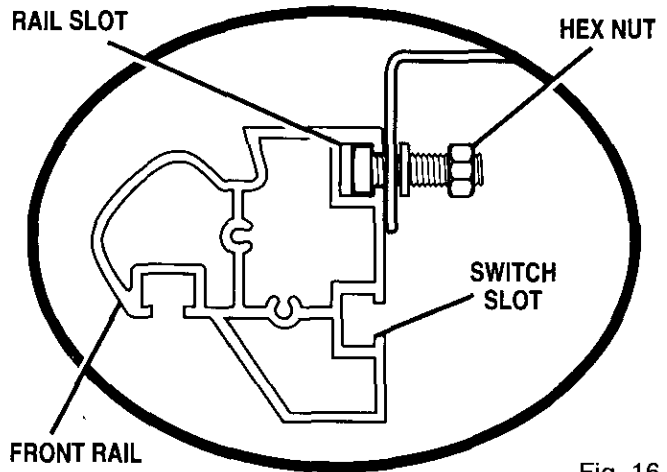

Fig. 16

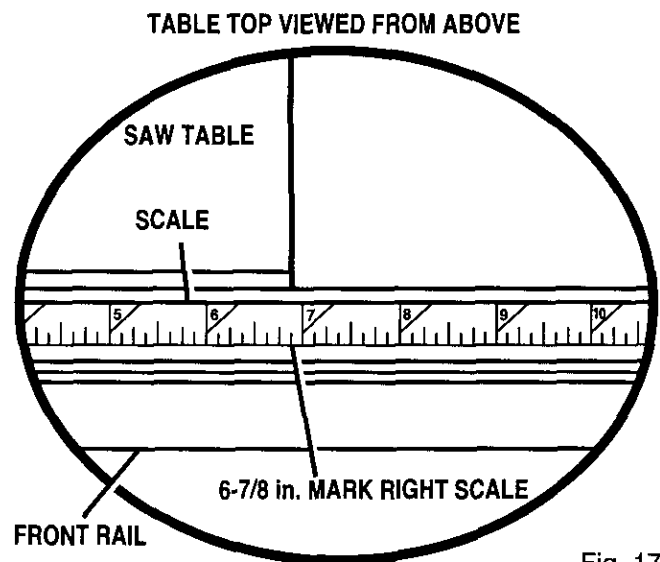

Fig. 17

ASSEMBLING MDF TABLE EXTENSION

See Figure 18.

- Locate the MDF table extension and the small hardware bag with the following:
 - 4 square head bolts (5/16-18 x 3/4 in.)
 - 4 hex nuts (5/16-18)
 - 4 flat washers (5/16 in.)
- Insert the four square head bolts into the holes located on the front and rear edges of the MDF table extension. The square bolt heads must extend out.
- Attach a flat washer and a hex nut to each bolt. Finger-tighten each nut on the MDF table extension until head of bolt is approximately 1/8 in. from the frame of MDF table extension. Leave just enough clearance so that bolts do not rotate and bind when sliding in rail slots.
- The back of the front rail has two slots. See Figure 16. Slide the bolt heads into the upper slot of front rail. (Bottom slot is for switch.)

ASSEMBLY

ASSEMBLING MDF TABLE EXTENSION (Continued)

- At the same time, slide the bolt heads into the rear rail slot.
- Slide MDF extension table along front and rear rails to desired location.
- Using a framing square, check to make sure MDF extension table is level with saw table. It should be flush or slightly below saw table.
- Loosen hex nuts as needed and adjust table using loose play in bolt holes.
- Tighten hex nuts securely.

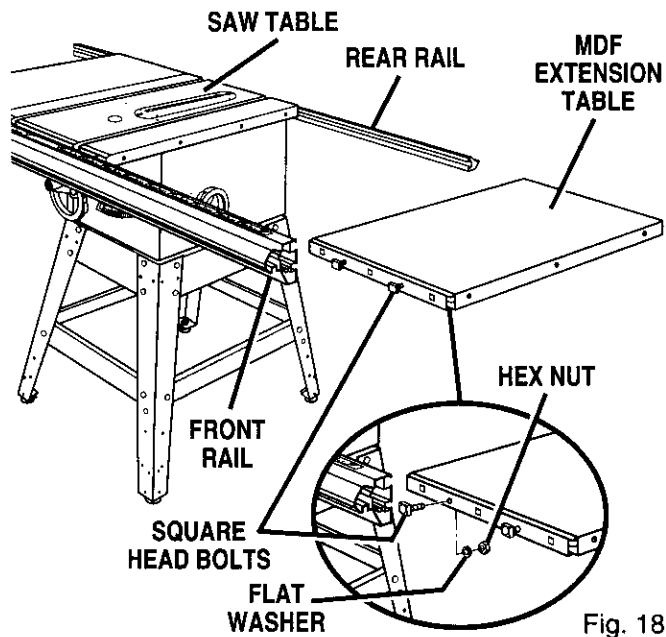

Fig. 18

ASSEMBLING STORAGE HANGERS

See Figure 19.

The large hangers are for storing the rip fence and the small hangers are for storing the miter gage.

- Locate the storage hangers.

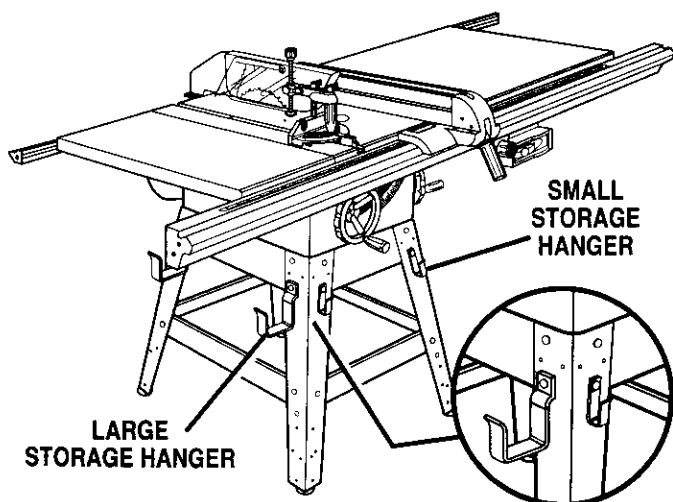

Fig. 19

- On the front at the top of the leg stand, remove one of the lower carriage bolts. See Figure 19.
- Insert carriage bolt in a small hanger and install in front leg. Attach the washer and hex nut from the back and tighten. Repeat for the other small hanger.
- Install the large hangers on the left side. See Figure 19.

INSTALLING THE MICRO-ADJUST

See Figure 20.

The micro-adjust indexes the rip fence. It includes a gear on the rip fence and gear racks mounted to the front rail.

- Locate the micro-adjust assembly, two racks, and the following hardware:
 - 10 pan head screws (#10-32 x 3/8 in.)
 - 8 square nuts (#10-32)
 - Hold a rack so the teeth point down and insert the pan head screws from the bottom. Put a square nut on each screw. Finger tighten, leaving a small gap between the nut and the rack.
 - Still holding the rack with teeth down, slide the square nuts into the right side of the front slot of the front rail until the end of the rack is near the center of the table.
 - Slide the other gear rack into the front rail from the left until the two racks meet in the middle. Securely tighten screws.
- Note:** The two racks must be touching for the micro-adjust assembly to roll from one gear rack to the other.

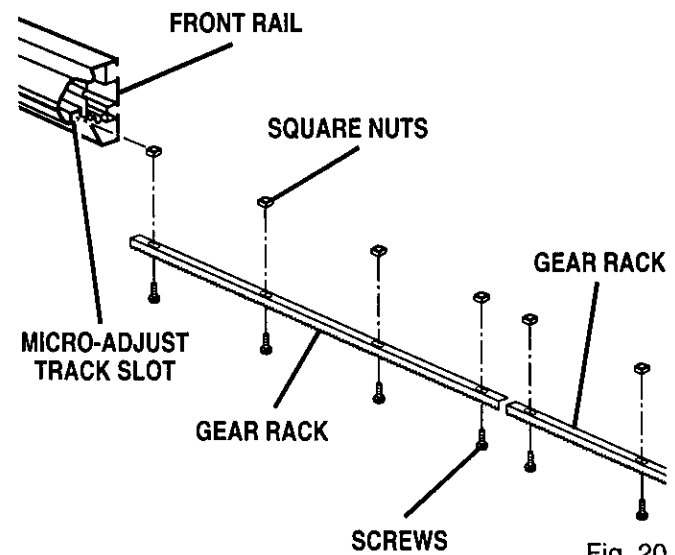

Fig. 20

ASSEMBLY

- Insert the two remaining pan head screws into holes in the micro-adjust knob bracket.
- Attach the micro-adjust knob bracket to the bottom of the fence head on the right or the left side of the fence handle. Securely tighten the two screws.

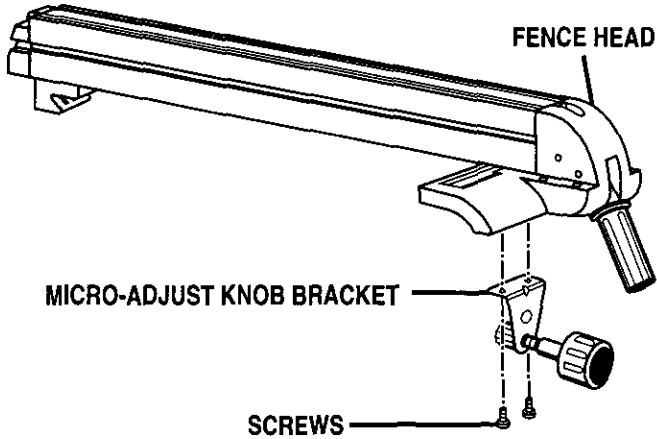

Fig. 21

ALIGNING THE RIP FENCE AND RAILS

See Figures 22 and 23.

The rip fence scale indicator is installed on the right side of the rip fence but can be removed and re-installed on the left side if needed. If a cutting operation requires placing the rip fence on the left side of the blade, and you find relocating the indicator necessary, simply unscrew and re-attach it.

- Hook the back of the rip fence over the rear rail. Lower the front of the rip fence into the groove on the front rail. See Figure 22.
- Slide the rip fence back and forth. It should move freely with about 1/16 in. clearance between the rip fence and table surface. If it doesn't, loosen the nuts holding the front and rear rails and adjust the rails up or down. See Figure 15.

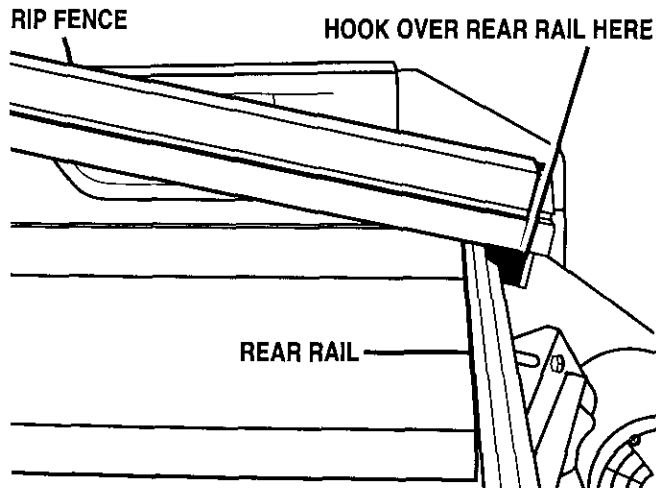

Fig. 22

- Remove the rip fence and repeat on the other side of the blade. When the fence rides smoothly, tighten all rail hex nuts with a 12 mm wrench.
- Push in the micro-adjust knob and turn it. The gear on the shaft assembly will engage the rack teeth on the rack and will move the fence assembly left or right.
- Push down on the rip fence handle to lock the rip fence in place.

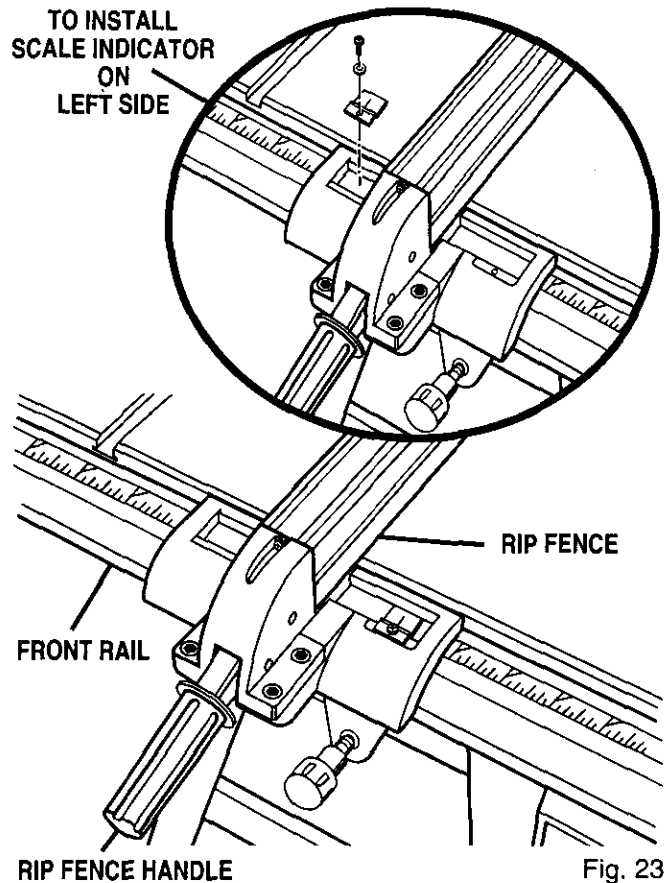

Fig. 23

ASSEMBLY

MOUNTING THE MOTOR AND SWITCH

See Figures 24, 25, and 26.

- Locate the motor and switch assembly, the motor mounting plate and the following hardware:

- 4 hex bolts (5/16-18 x 1 in.)
- 8 flat washers (5/16 in.)
- 4 lock washers (5/16 in.)
- 4 hex nuts (5/16-18)
- 2 hex bolts (5/16-18 x 3/4 in.)
- 2 screws (1/4-20 X 3/8 in.)
- 2 square nuts (1/4-20)
- Yellow Switch key

Note: Remaining hardware from this bag is used for installing the belt guard.

- Release the bevel lock handle (front of the cabinet) and turn the bevel handwheel (right side of the cabinet) until the blade is fully vertical. Retighten the bevel lock handle.
- Align the holes in the motor mounting plate and the motor bracket so the top edges are even. Place a flat washer on the four 1 in. bolts and insert them into the holes.
- Install a flat washer, a lock washer, and a hex nut on each bolt. Hand tighten only. This is the motor support assembly.
- Center the motor side to side on the motor mounting plate. Tighten the nuts with a 12 mm wrench.
- Insert the two rods on the motor support assembly into holes in the cradle. Push the motor in as far as it will go. Thread the two 3/4 in. hex bolts into the cradle to clamp down on the rods. **Do not securely tighten bolts yet.**

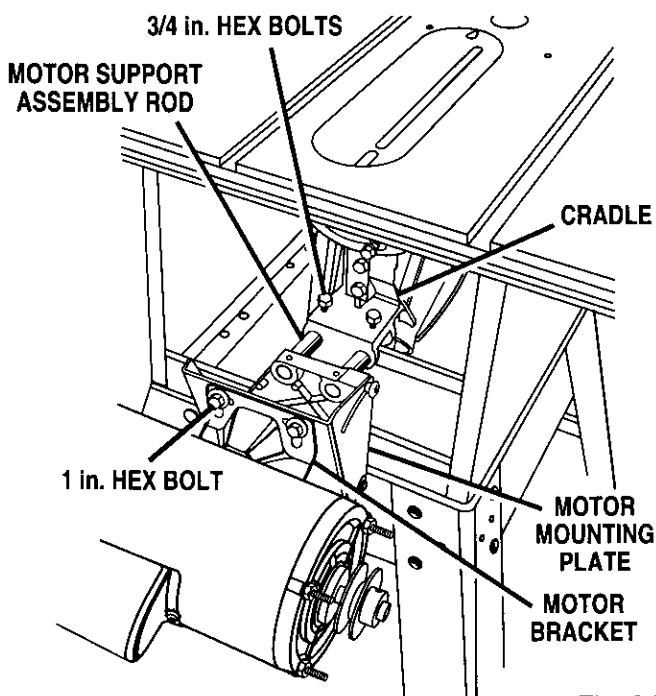

Fig. 24

- Locate the switch assembly, two screws (1/4-20 x 3/8 in.) and two square nuts (1/4-20). Insert the screws from the rear of the switch plate and add the square nuts on the front.

- Holding the switch to the front, insert and slide the two square nuts into the lower slot of the front rail.

⚠ WARNING: Place the switch out of the immediate work area to avoid accidentally turning it off during operation.

- Slide the switch assembly to a convenient position, leaving ample clearance for the handwheel. Tighten securely with a screwdriver.

- Install the yellow switch key on the switch. See Figure 60.

- Put the end caps on the rail ends. Insert the screws and tighten with a phillips screwdriver. See Figure 26.

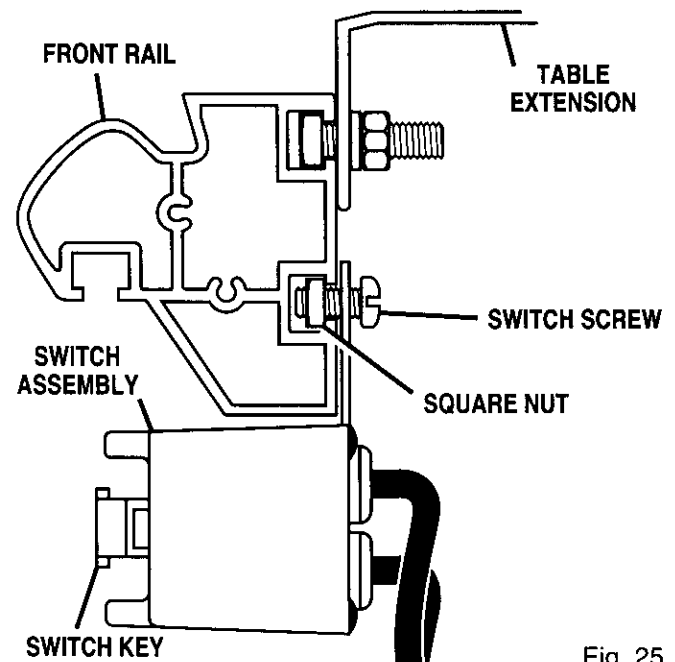

Fig. 25

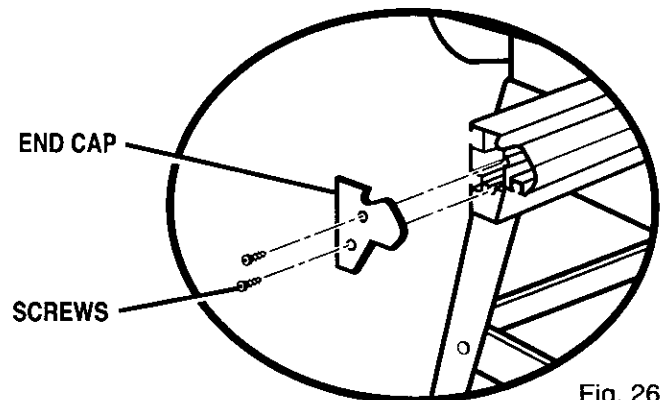

Fig. 26

ASSEMBLY

INSTALLING THE BELT AND BELT GUARD

See Figures 27 and 28.

- Locate the belt, belt guard, 4 flat washers (#10) and 4 small hex nuts (#10-24). Locate the dust cover and hardware.
- Lower the blade by turning the height handwheel on the front of cabinet.
- Slip the belt on the saw pulley inside the saw cabinet. Lift the motor forward and place the belt on the motor pulley.
- Check that the belt is straight and both pulleys are aligned with each other. If not, adjust the motor on the motor support assembly. Refer to *Mounting the Motor*.
- Raise the saw blade all the way up.
- Pull the motor out until the belt is taut. Securely tighten the hex bolts above the rods with a 12 mm wrench.
- Put your hand around the belt halfway between the two pulleys and squeeze the belt until both sides of the belt touch. The motor should move freely as you squeeze the belt. If it does not, loosen the clamp screws and readjust the belt tension.

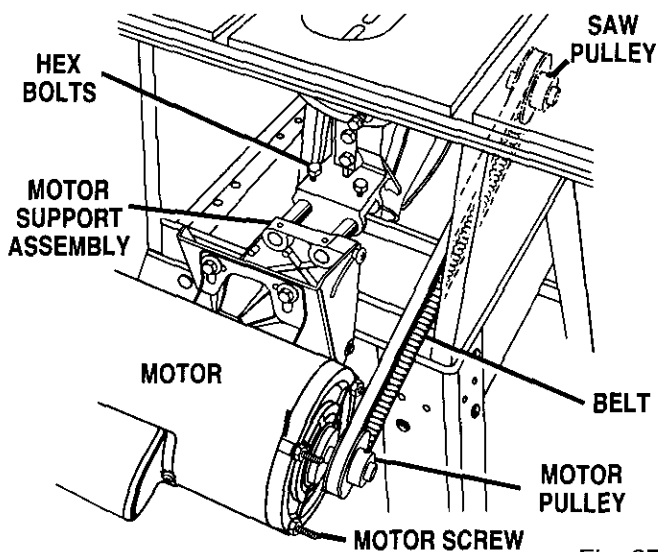

Fig. 27

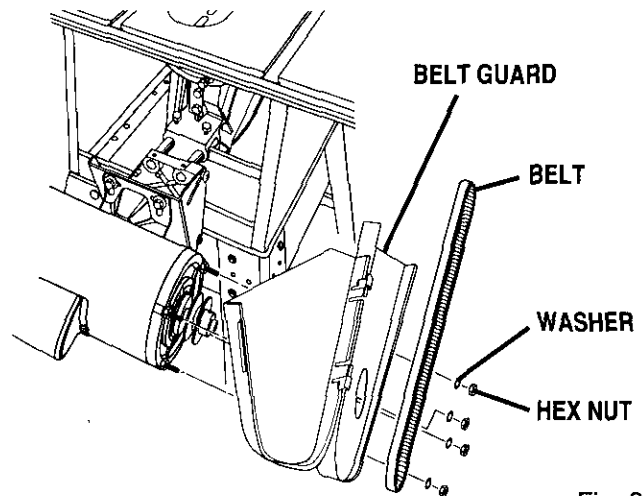

Fig. 28

- Lower the blade by turning the height handwheel. Lift the motor forward and remove the belt.
- Open the hinged belt guard and place it over the motor screws on the motor pulley. Secure with flat washers and hex nuts. Tighten the hex nuts with a 8 mm wrench.
- Replace the belt and snap the guard closed.
- Check clearances by indexing the blade. Release the bevel lock handle on the front of the cabinet and turn the bevel handwheel on the right side of cabinet to 45° and back. Use the height handwheel to fully lower and raise the blade.

ASSEMBLY

INSTALLING THE BLADE GUARD

See Figures 29, 30, and 31.

⚠ WARNING: If the blade is not fully lowered, turn the height handwheel on the front of the cabinet to lower the blade to prevent the risk of injury.

- Locate the blade guard, the blade guard bracket, and the following hardware:
 - 2 hex bolts (5/16-18 x 1/2 in.)
 - 2 lock washers (5/16 in.)
 - 3 socket head screws (1/4-20 x 3/8 in.)
 - 3 flat washers (1/4 in.)
- Align the lower end of the blade guard bracket and the threaded holes of the cradle and insert the two hex bolts and lock washers. Securely tighten with a 12 mm wrench. See Figure 29.
- Remove the throat plate. See *Removing / Replacing the Throat Plate* in the Adjustments section.
- Put the blade guard assembly in place on the tabletop, aligning the screwholes in the riving knife to the holes in the blade guard bracket. Align the hole in the front of the riving knife base with screw hole in the cradle. See Figure 30.

Note: The screw hole is located under the slot in back of the throat plate.

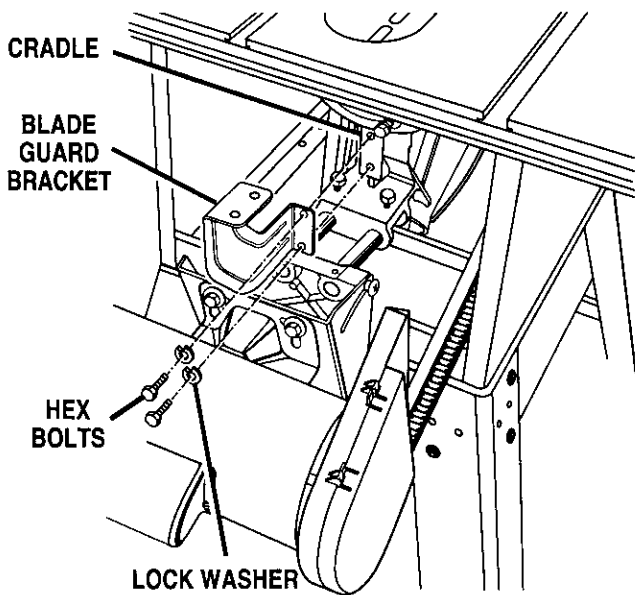

Fig. 29

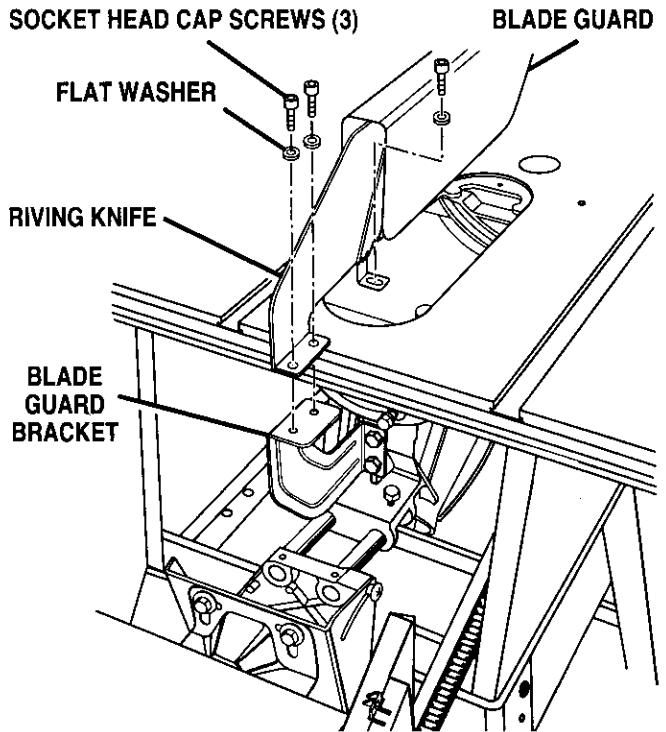

Fig. 30

- Insert two socket head screws and two flat washers in the two holes at the back of the riving knife base. Securely tighten with a 5 mm hex key.
- Insert the third socket head screw and a flat washer into the screw hole in the cradle under the throat plate. Securely tighten with a 5 mm hex key. See Figure 31.
- Replace the throat plate.

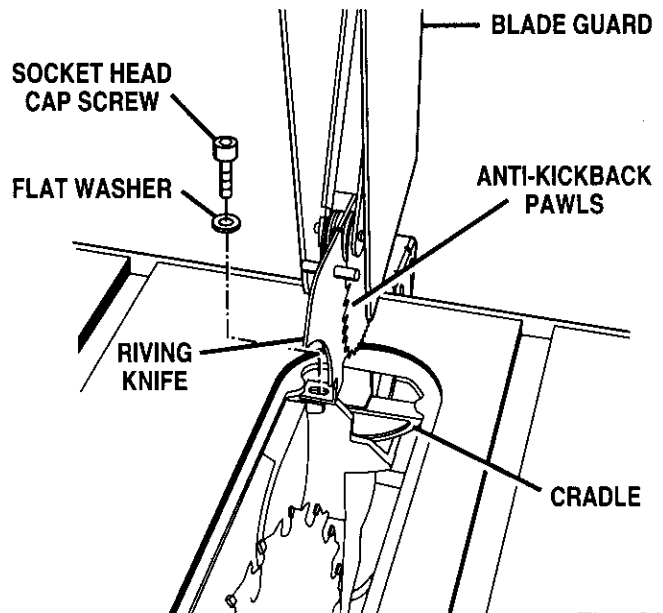

Fig. 31

ASSEMBLY

CHECKING THE THROAT PLATE

See Figure 32.

- ⚠ **CAUTION:** The throat plate must be even with the table surface. If it is too high or too low, the workpiece can catch on uneven edges and cause kickback.
- Make sure the throat plate is flush with the table top. To change the height of the throat plate, loosen the flat head screw that secures the throat plate and adjust the four setscrews on the throat plate with a 2 mm hex key. Do not allow the throat plate to bow up above the table surface.

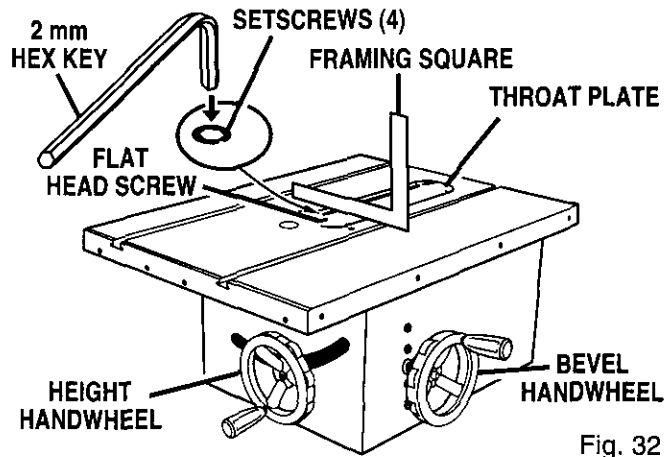

Fig. 32

ALIGNING RIVING KNIFE WITH THE BLADE

See Figures 33, 34, and 35.

- ⚠ **WARNING:** Make sure the switch is off, the switch key is removed, and the saw is unplugged. Failure to do so could result in accidental starting, causing serious injury.

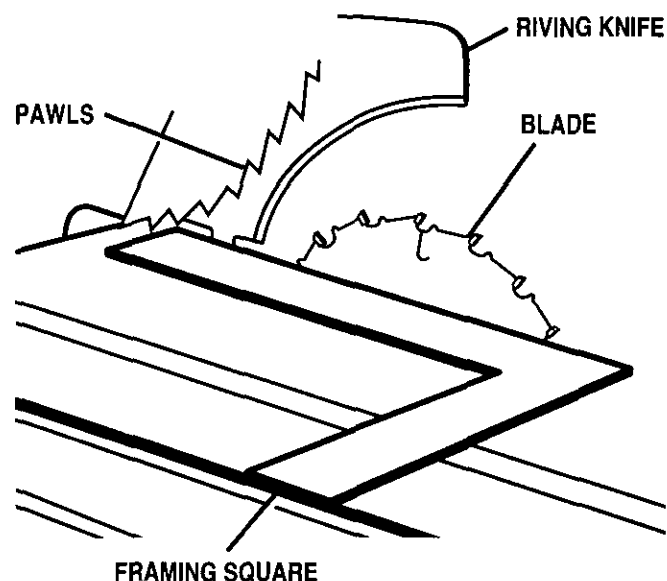

Fig. 33

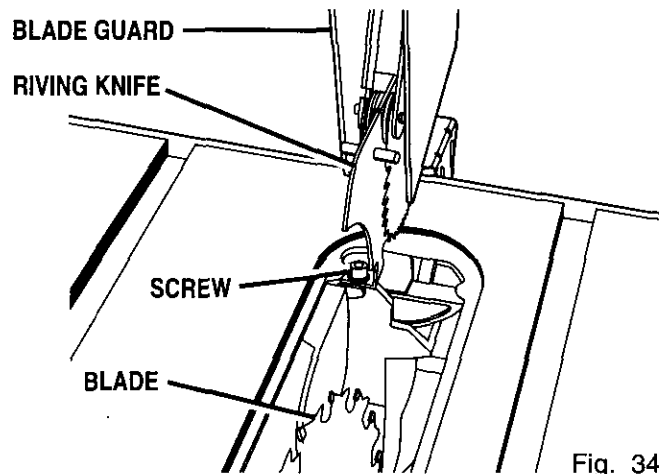

Fig. 34

- ⚠ **WARNING:** It is important to install and adjust the riving knife correctly. Poor alignment could cause kickback and throw the workpiece at the operator.

The riving knife must be aligned with and centered over the blade.

- Raise the blade and the blade guard.
- Place a framing square or straightedge beside the blade on the left. See Figure 33.
- Loosen front screw on riving knife with a 5 mm hex key. See Figure 34.

- ⚠ **WARNING:** Do not loosen the screws holding the riving knife to the blade guard bracket. Unsecured pawls or riving knife could cause personal injury while you are adjusting the riving knife.

- Center riving knife over the blade. See Figure 35.
- Securely tighten screw with a 5 mm hex key.

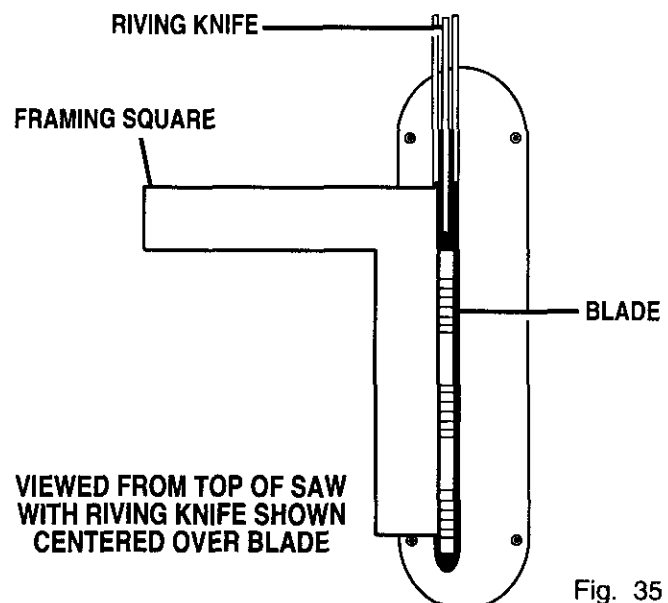

Fig. 35

ASSEMBLY

CHECK HEELING (PARALLELING) OF THE SAWBLADE TO THE MITER GAGE GROOVE

See Figures 36 and 37.

Do Not loosen any screws until you have checked with a square and made sure adjustments are necessary. Once the screws are loosened, these items must be reset.

WARNING: Make sure the switch is off, switch key is removed and saw is unplugged. Failure to do so could result in accidental starting causing serious personal injury.

WARNING: The sawblade must be parallel to the miter gage groove so the wood does not bind, resulting in kickback. You could be hit or cut.

- Lift the blade guard. Raise the blade all the way by turning the height handwheel.
- Mark beside one of the sawblade teeth at the front of the blade. Place a framing square beside the blade on the mark. Be sure the framing square is between the teeth and flat against the blade. Measure the distance to the right gage groove.
- Turn the sawblade so the marked tooth is at the back.
- Move the square to the rear and again measure the distance to the right miter gage groove. **If the distances are the same, the blade and the miter gage groove are parallel. No adjustments are needed.**
- If the distances measured are different, adjust the table bracket underneath the saw. See “Heeling (Paralleling) The Sawblade To The Miter Gage Groove” in the Adjustments section.

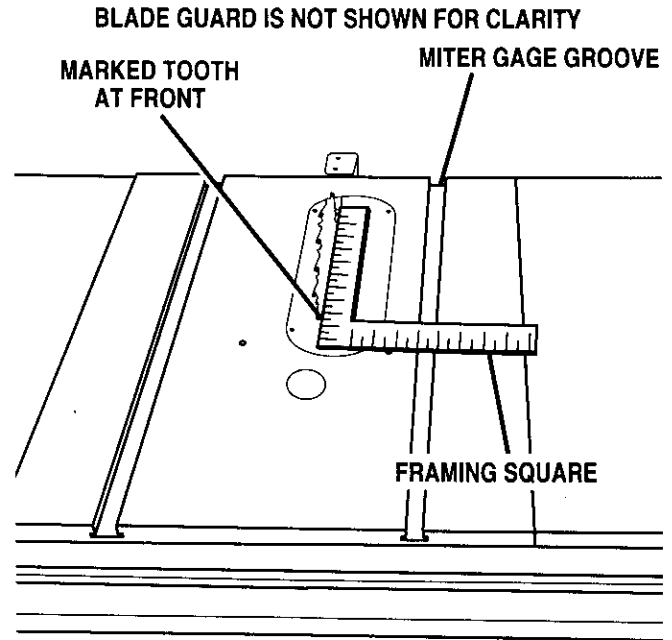

Fig. 36

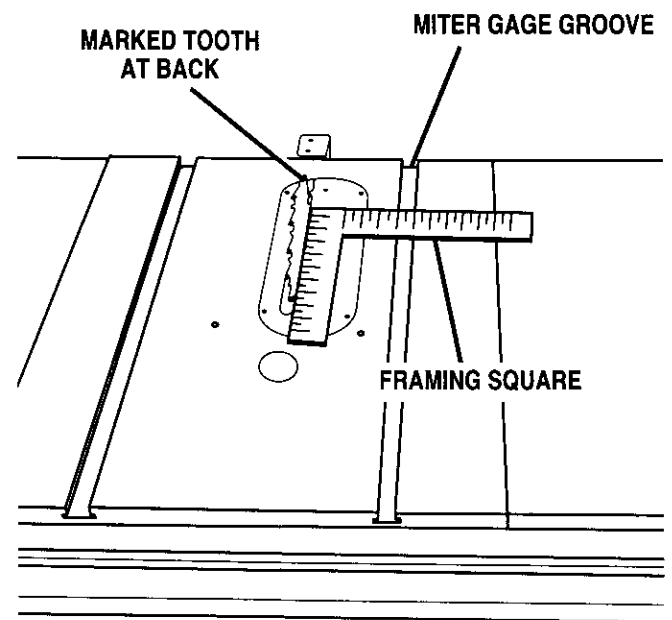

Fig. 37

ASSEMBLY

CHECKING RIP FENCE AND BLADE ALIGNMENT

See Figures 38, 39, and 40.

The rip fence is self-aligning but should be checked before first use.

- ⚠ **WARNING:** Failure to align the rip fence to the blade can cause jams and kickback, resulting in serious personal injury.
- Slide the rip fence to the miter gage groove, which is parallel to blade. Do not lock the rip fence.
- Place a framing square against the rip fence, with the long end towards the front of the blade. See Figure 38. Measure the distance from the rip fence to the edge of the blade.
- Move the square to the back of the blade and measure the length from other end of the rip fence to the blade. See Figure 39.
- If the distances are different, loosen the four screws around the rip fence handle with a 6 mm hex key. Alternate the order (remove the screw opposite, not next to the first one). See Figure 40.
- Hold the fence handle against the front rail and align the rip fence with the blade.
- Retighten the screws in alternating order and check the alignment.

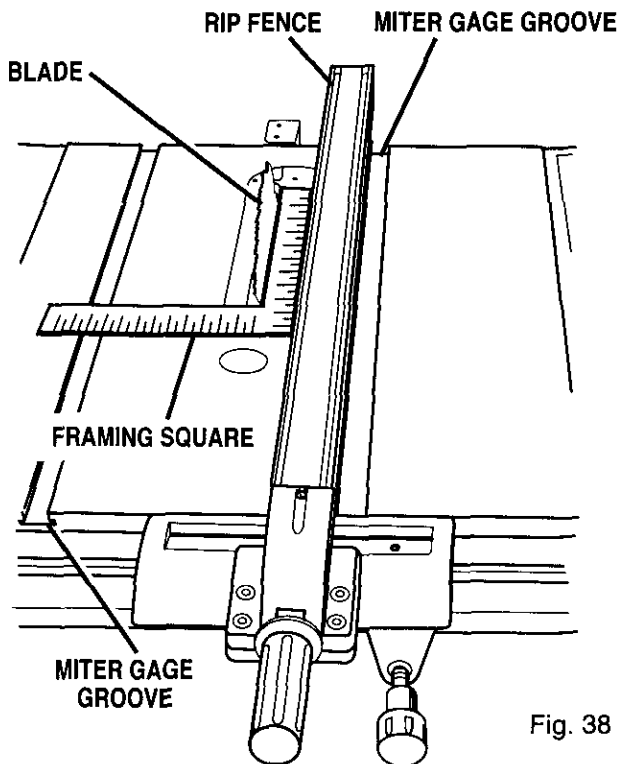

Fig. 38

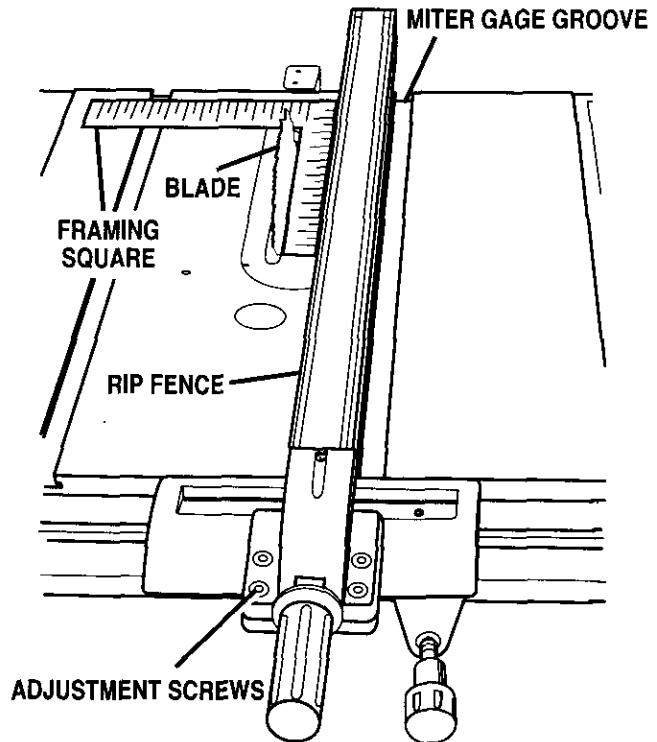

Fig. 39

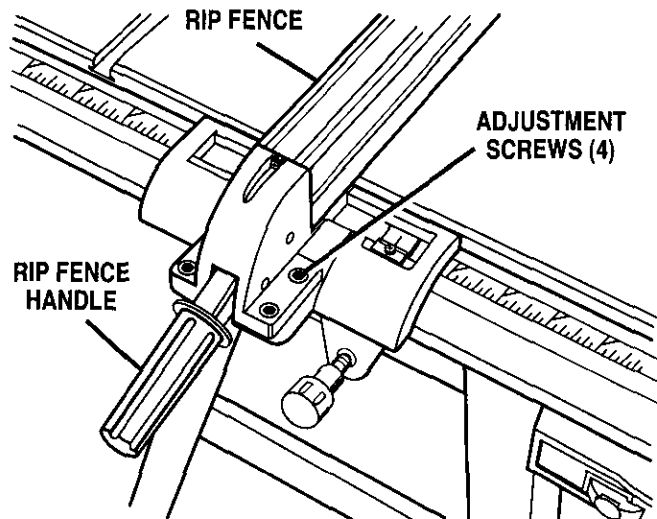

Fig. 40

- Repeat until the rip fence is aligned.
- Lock the rip fence handle in desired position by rotating the handle down.

Note: To insure proper self alignment when positioning rip fence, push sides of scale indicator housing against front rail before locking rip fence handle.

ASSEMBLY

CHANGING THE MOTOR VOLTAGE

See Figures 41 and 42.

⚠ WARNING: If you are unfamiliar with the basic fundamentals of electricity do not attempt this procedure. Use a qualified electrician to change the voltage of the saw to avoid electric shock or possibly a fire.

Your saw is set at the factory for 120V usage. See Figure 41. Use extreme caution in changing to 240V, as with any electrical procedure. Check the receptacle. It must be a 220-240V, 15 amp, 3-blade unit -- connected to a 240V AC power supply -- through a 240V branch circuit -- with at least a 15 amp capacity -- and protected by a 15 amp time-delay fuse or circuit breaker. All attachment plugs and any receptacles designed for 120 volt usage must be replaced with devices rated for 240 volts.

⚠ WARNING: Never connect the plug to the power source outlet until all assembly steps are completed. Unplug the saw before changing any connections.

■ Open the motor connector box cover on the end of the motor with a phillips screwdriver. Remove the brown motor lead from terminal #2 and attach it to the #3 terminal.

Note: The brown lead is not needed in 240V usage.

- Remove the yellow motor lead from terminal #1 and attach it to terminal #2.
- Cut off the 120V power cord plug and replace it with a three-blade 240V, 15 amp U.L. listed plug.
- Connect the power cord white and black leads to the "hot" plug blade terminals.
- Connect the power cord green grounding wire to the plug ground prong terminal.
- Close the motor connector box. Be careful to place the power cord in the strain relief groove. Tighten the box cover screws.
- Plug the saw into the appropriate 220-240V, 15 amp, 3-blade receptacle.
- Make sure the receptacle is connected to a 240V AC power supply through a 240V branch circuit having at least a 15 amp capacity and protected by a time delay fuse or circuit breaker of the correct size.

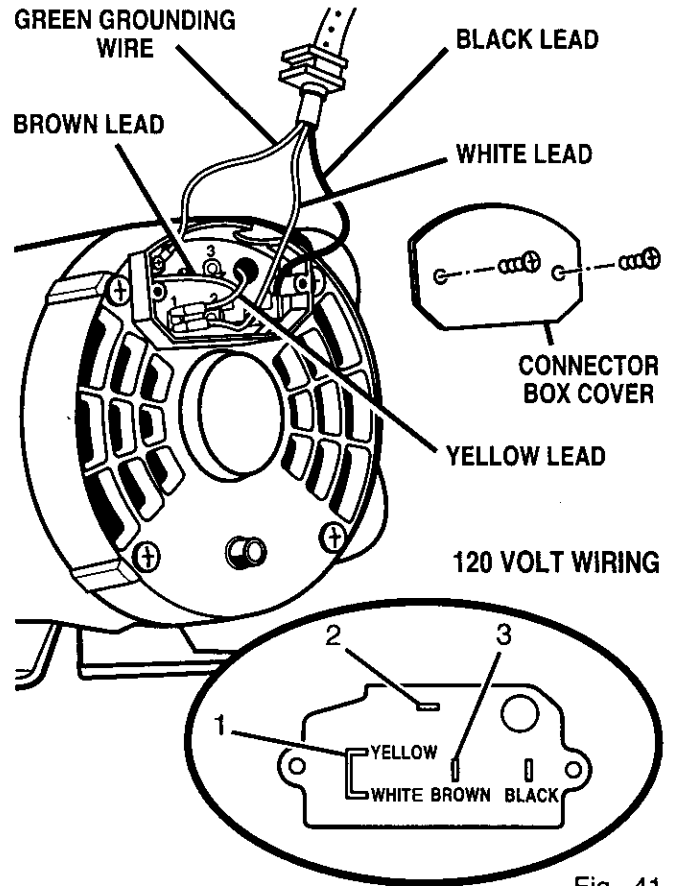

Fig. 41

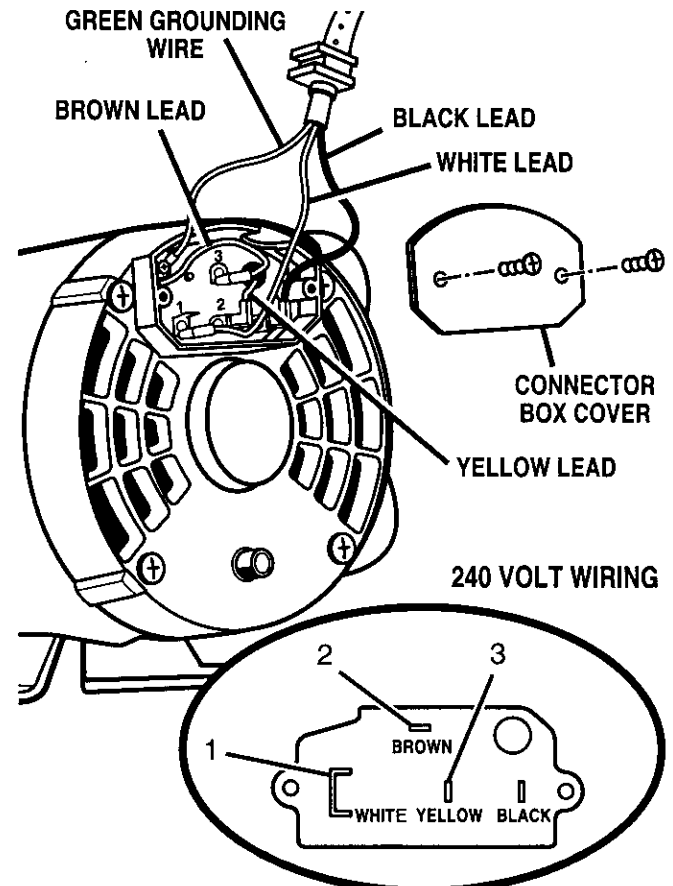

Fig. 42

ASSEMBLY

ASSEMBLING THE HOLD DOWN CLAMP ON THE MITER GAGE

See Figures 43, 44, and 45.

The miter gage should be used when making cross cuts in the workpiece. The hold down clamp with quick release button helps hold the workpiece against the miter gage for controlled cutting.

- Locate the bag with the hold down clamp parts.
- Slide the quick release button into the clamp housing aligning the holes for the clamp screw.

Note: The quick release button must be oriented with the solid side toward the long body of the clamp housing, as shown. See Figures 43 and 44.

QUICK RELEASE BUTTON VIEWED FROM ABOVE

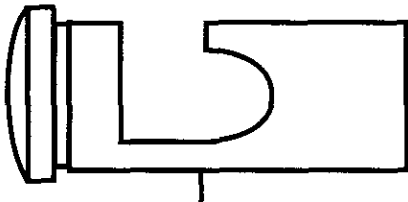

SOLID SIDE

Fig. 43

- Insert the clamp screw through the clamp housing and quick release button from the bottom. Thread the round knob on top of the clamp screw.
 - Install the spring with a screw on the back side of the quick release button. Do not over tighten.
 - Push the quick release button. The clamp screw with knob should drop.
- Note:** If the clamp screw does not move freely the quick release button may be oriented incorrectly. Remove the clamp screw and roll the quick release button 180°. Insert the clamp screw and attach knob.
- Install the lock tab with a screw next to the quick release button.
 - Thread the spacer into the hole on top of the miter gage base.
 - Align the clamp housing on top of the miter gage knob and the spacer.
 - Place a washer on each lock knob and attach one lock knob to the top of the spacer and one lock knob to the top of the miter gage knob.

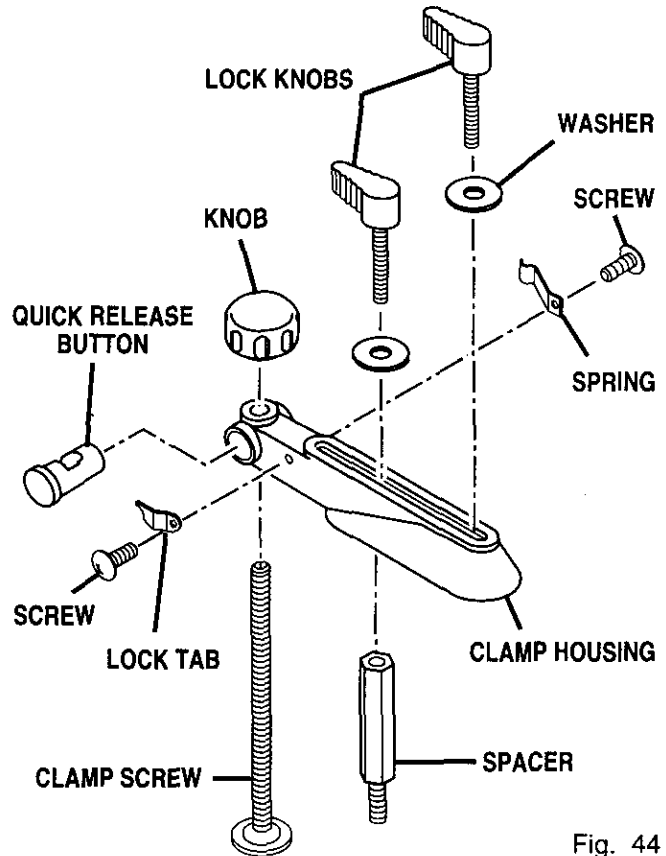

Fig. 44

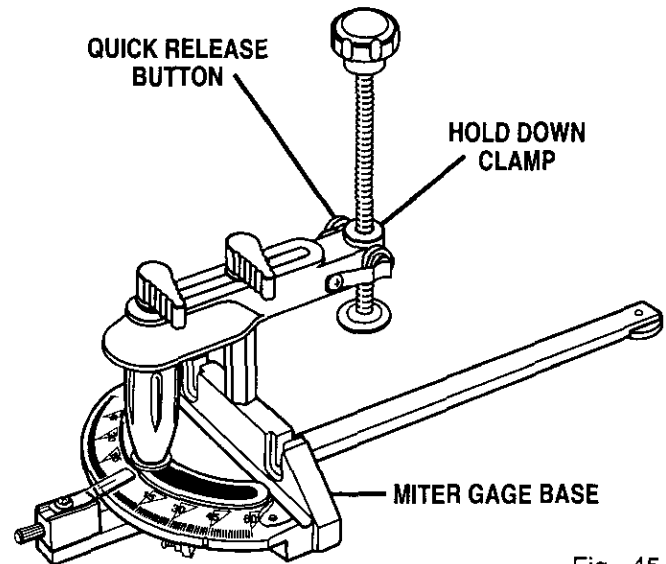

Fig. 45

ADJUSTMENTS

To avoid unnecessary setups and adjustments, a good practice is to check your setups carefully with a framing square and make practice cuts in scrap wood before making finish cuts in good workpieces. Do not start any adjustments until you have checked with a square and made test cuts to be sure adjustments are needed.

REPLACING THE BLADE

See Figures 46, 47, and 48.

⚠ WARNING: Be sure the switch is off, the switch key is removed, and your saw is unplugged. Failure to do so could result in accidental starting resulting in possible serious personal injury.

- Raise the blade guard and remove the throat plate by loosening the screw at the front with a phillips screwdriver and lifting the front of the throat plate. Pull it out toward the front.
- Raise the blade to its highest position by turning the height handwheel clockwise. Angle the blade straight up by loosening the bevel lock handle (front of the cabinet) and turning the bevel handwheel. Wedge a piece of scrap wood against the front of the blade. See Figure 46.
- Loosen the blade nut with the blade wrench provided with your saw. Remove the blade nut and blade washer. Carefully remove the scrap wood block and blade.
- To replace the blade with an accessory blade, use the instructions provided with the accessory.
- To install a standard blade, place the new blade on the arbor shaft, with teeth pointing down toward the front of the saw. See Figure 47.
- Wedge a block of wood at the back of the blade. See Figure 48.

⚠ CAUTION: The teeth must point down toward the front of the saw to work properly. Otherwise, damage to the blade, saw, or workpiece can occur.

- Place blade washer and blade nut over blade arbor. Be sure the dome side of blade washer faces out from the blade and that all items are snug against the arbor housing. Tighten securely.
- Remove wood and rotate the blade by hand to make sure it turns freely.
- Lower the blade and slip the throat plate into the opening and push it toward the back of the saw to engage the spring clip. Securely tighten the screw. If the throat plate is not flush with the table, adjust the setscrews with a 2 mm hex key. Do not let the throat plate bow up above the table surface.

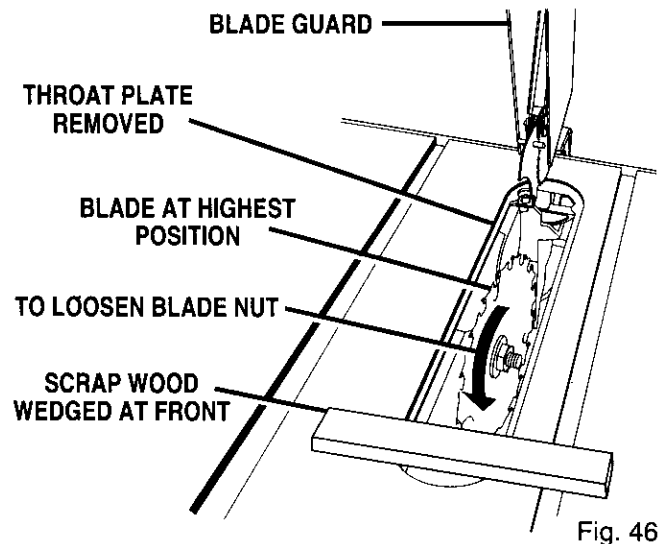

Fig. 46

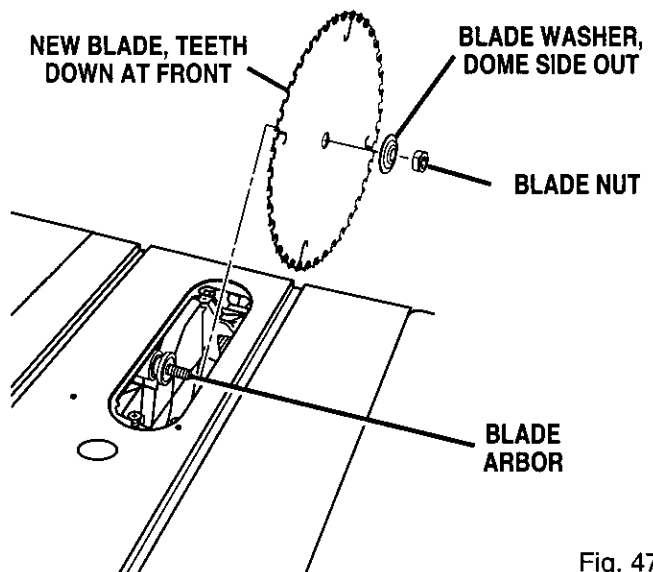

Fig. 47

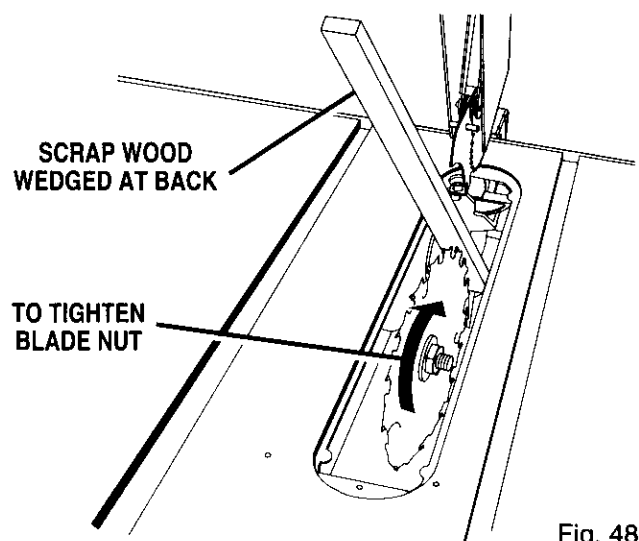

Fig. 48

ADJUSTMENTS

HEELING (PARALLELING) THE SAWBLADE TO THE MITER GAGE GROOVE

See Figures 49, 50 and 51.

Do Not loosen any screws for this adjustment until you have checked with a square and made test cuts to be sure adjustments are necessary. Once the screws are loosened, these items must be reset.

WARNING: Make sure the switch is off, switch key is removed and saw is unplugged. Failure to do so could result in accidental starting causing serious personal injury.

WARNING: The sawblade must parallel the miter gage groove so the wood does not bind, resulting in kickback. You could be hit or cut.

- Lift the blade guard. Raise the blade all the way by turning the height handwheel.
- Mark beside one of the sawblade teeth at the front of the blade. Place a framing square beside the blade on the mark. Be sure the framing square is between the teeth and flat against the blade. Measure the distance to the right miter gage groove.
- Turn the sawblade so the mark is at the back of the saw table.
- Move the square to the rear and again measure the distance to the right miter gage groove. If the distances are the same, the blade and the miter gage groove are parallel.
- If the distances measured are different, adjust the table brackets underneath the saw.

WARNING: When reaching under the saw table, wear gloves. Accidental contact with the blade could cause a cut resulting in serious personal injury.

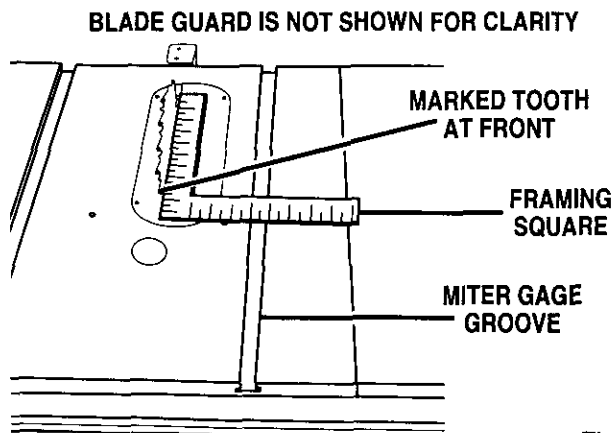

Fig. 49

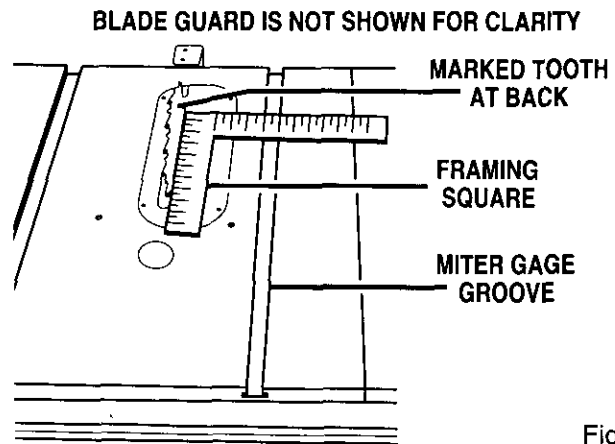

Fig. 50

- Remove the throat plate by loosening the front screw with a phillips screwdriver. Lift the throat plate and pull it out by the front end.
- Lower the blade completely with the height handwheel. You can then access the table brackets through the throat plate opening.
- From the back of the saw, loosen the three screws on the rear table bracket with a 12 mm wrench. See Figure 51.
- If the blade was too far from the miter gage groove, move the bracket toward the miter gage groove. Tap with a wood block and hammer.
- If the blade was too close to the miter gage groove, back the bracket away with the block of wood and hammer.
- Tighten the screws, raise the blade and recheck.

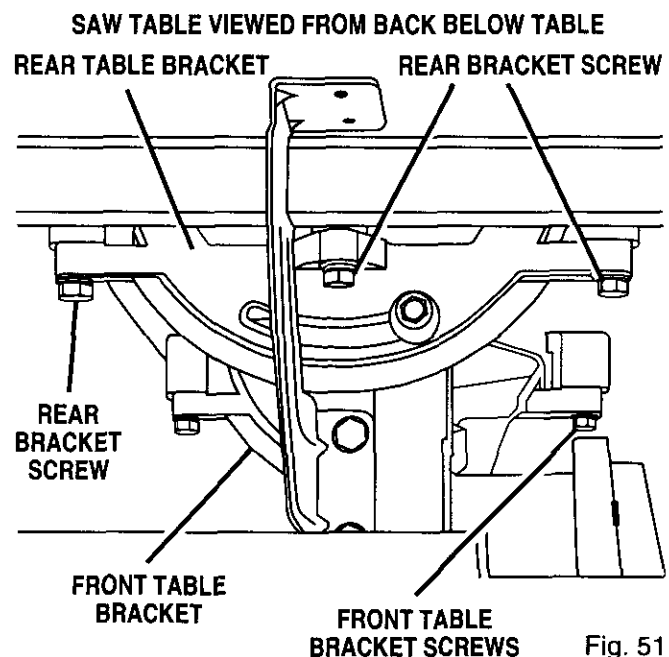

Fig. 51

ADJUSTMENTS

- If the blade is still not parallel, adjust the front table bracket. Tilt the blade to 45° with the bevel lock handle and bevel handwheel.
- From the back of the saw, loosen bolts holding the front table bracket, as well as the rear table bracket.
- Reposition the blade to 90° with the bevel handwheel and bevel lock handle.
- Lower the blade and move the brackets as needed. Retighten all bracket screws.
- Raise the blade and recheck. Repeat until the blade is parallel to the miter gage groove.
- Place the throat plate in the opening and push it toward the rear of saw base to engage the spring clip.

Note: The keyslot in the throat plate will drop over the front screw.

- Tighten the screw. Do not allow the throat plate to bow up above the table surface.

SETTING THE BEVEL STOPS AND INDICATOR

See Figures 52 and 53.

Wait to loosen any screws for the adjustments until you have checked with a square and made test cuts to be sure adjustments are necessary. Once the screws are loosened, these items must be reset.

⚠ WARNING: Make sure the switch is off, the switch key is removed, and the saw is unplugged. Failure to do so could result in serious personal injury.

The bevel scale should show 0 when the blade is set at 90° and 45° when blade is at a 45° tilt.

- Raise the blade all the way up by turning the height handwheel. Lift the blade guard.
- Loosen the bevel lock handle and turn the bevel handwheel clockwise to tilt the blade. Reverse it and turn the handwheel counterclockwise until it stops.
- Check the blade angle with a combination square. Don't let the square touch a blade tooth. The blade should be at 90° and the scale indicator at 0.

Note: The scale indicator is the plastic plate on the scale at the front of the cabinet.

- If the scale indicator does not point to 0, loosen the scale indicator with a screwdriver, adjust it within the slot and retighten the screw.

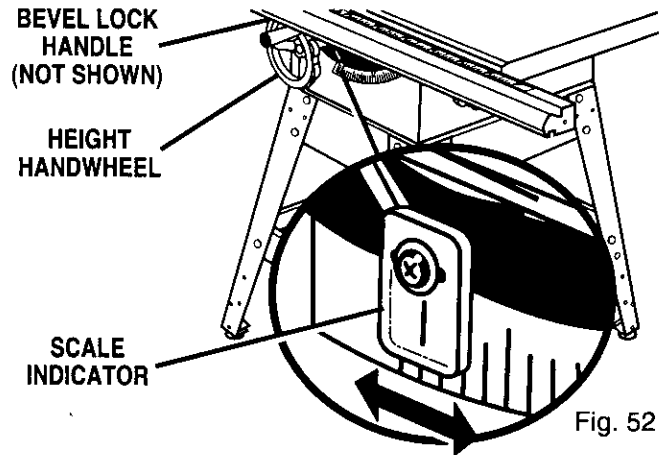

Fig. 52

- If the blade angle is wrong, adjust the 90° stop screw (left of the blade, looking from the front). See Figure 53. Start by turning the 90° stop screw three or four times with a 4 mm hex key.
- Turn the bevel handwheel clockwise once, then back counterclockwise to square blade with table.
- Tighten the 90° stop screw and recheck that the blade is square in a 90° position. If not, repeat. When blade is square, check scale indicator. If it is not at zero, reset scale indicator as before.
- Check the 45° setting. Tilt the blade with the bevel handwheel as far as it will go left. Place the square against the blade (be sure the square is not against one of the saw teeth). If the blade is not at 45°, unscrew the 45° stop screw (right of blade), turn the handwheel until the blade is correct, and tighten the screw. Recheck and repeat if necessary.
- Check that the scale indicator is at 45°.
- If not, loosen the scale indicator with a screwdriver, adjust it within the slot and retighten the screw.

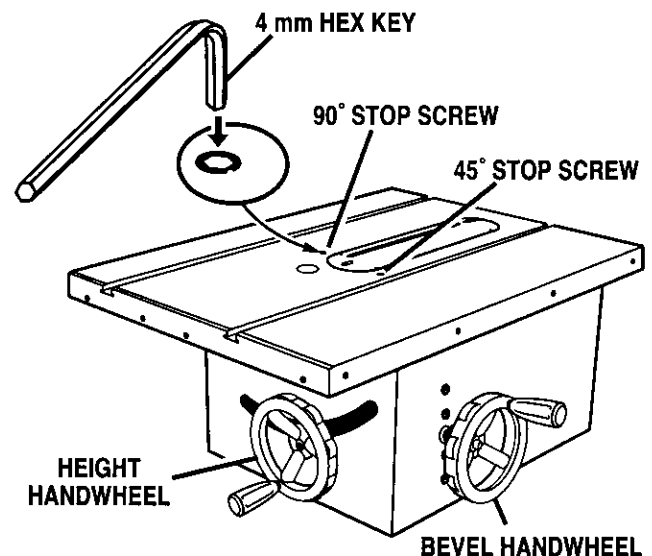

Fig. 53

ADJUSTMENTS

ADJUSTING THE MITER GAGE

See Figure 54.

The miter gage is used in making cross cuts in the workpiece. To use the miter gage at an angle other than 0, loosen the lock knob over the miter gage knob. Loosen the miter gage knob and pull out the stop pin. Move the miter gage rod to the desired angle and securely tighten the miter gage knob and the lock knob.

WARNING: Make sure the switch is off, the switch key is removed and the saw is unplugged. Failure to do so could result in serious personal injury.

- To check for alignment, set the miter gage at 0 and plus or minus 45° by pulling the miter gage stop pin. Adjust the stop screws, if needed.

Note: The miter gage provides close accuracy in angled cuts. For very close tolerances, test cuts are recommended.

- Loosen the lock nut of the 0 stop screw at the stop pin with an 8 mm wrench.
- Place a 90° square against the miter gage rod and the miter gage base.
- If the rod is not square, loosen both lock knobs on the top of the miter gage, adjust the rod, and tighten the lock knobs.
- Adjust the 0 stop screw until it rests against the stop pin. Adjust the plus and minus 45° stop screws using a 45° triangle and the steps above.
- Push the quick release to quickly move the hold down clamp onto the wood you are about to cut. To prevent the use of the quick release roll the quick release stop around to the top of the quick release. This prevents the hold down clamp from dropping on your workpiece.

REMOVING / REPLACING THE THROAT PLATE

See Figure 55.

WARNING: Make sure the switch is off, the switch key is removed, and the saw is unplugged. Failure to do so could result in serious personal injury.

- Loosen the screw in the throat plate with a phillips screwdriver and lift the front end of the throat plate. Pull it out toward the front of the saw.
- To re-install the throat plate, place it in the opening. Push it toward the rear of the saw base to engage the spring clip.

Note: The keyslot in the throat plate will drop over the screw.

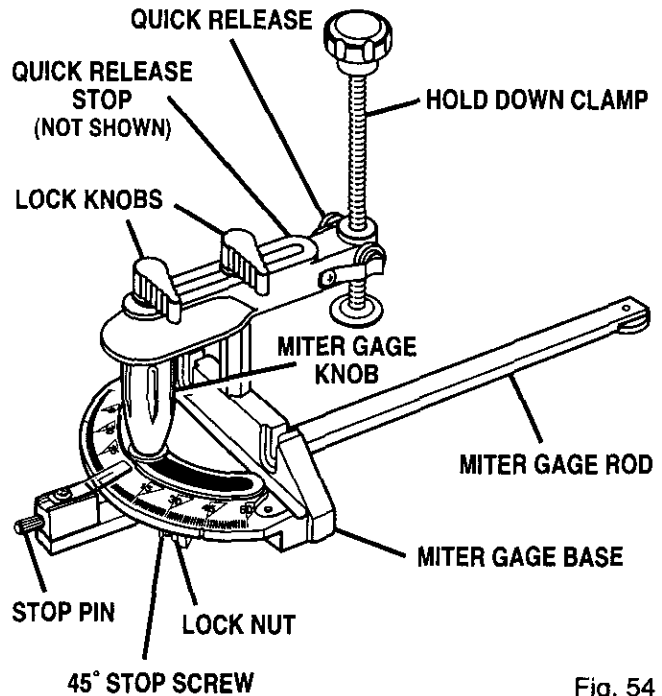

Fig. 54

- Check that the throat plate is even with the table top. If not, adjust the four corner setscrews with a 2 mm hex key. See the procedure in the *Assembly* section.
- Securely tighten the throat plate screw. Do not allow the throat plate to bow up above the table surface.

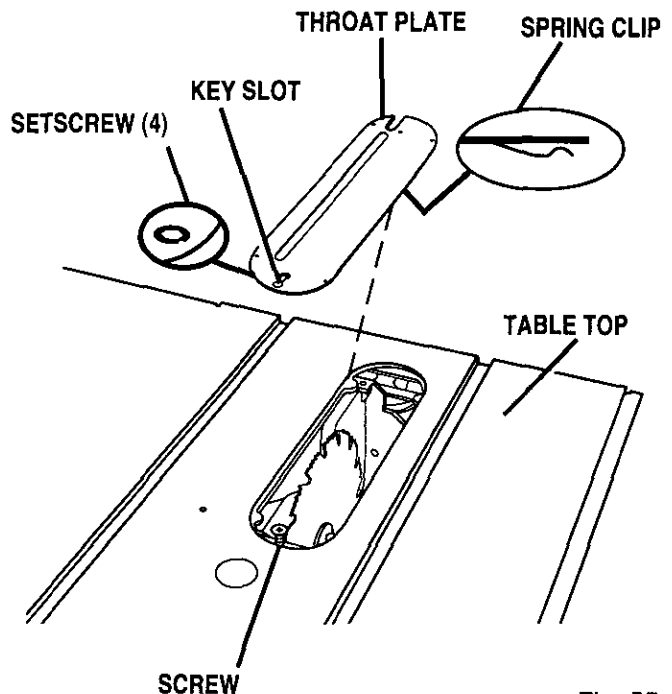

Fig. 55

OPERATION

BASIC OPERATION OF THE TABLE SAW

A table saw can be used for straight-line cutting operations such as cross cutting, ripping, mitering, beveling, compound cutting, and resawing. It can make dado or molding cuts with optional accessories.

The three-prong plug must be plugged into a matching outlet that is properly installed and grounded according to all local codes and ordinances. Improper connection of the equipment can result in electric shock. Check with an electrician or service personnel if you are unsure about proper grounding. Do not modify the plug; if it will not fit the outlet, have the correct outlet installed by a qualified electrician. Refer to the Electrical page of this manual.

Note: This table saw is designed to cut wood and wood composition products only.

CAUSES OF KICKBACK

Kickback can occur when the blade stalls or binds, kicking the workpiece back toward you with great force and speed. If your hands are near the sawblade, they may be jerked loose from the workpiece and may contact the blade. Obviously, kickback can cause serious injury, and it is well worth using precautions to avoid the risks.

Kickback can be caused by any action that pinches the blade in the wood, such as the following:

- Making a cut with incorrect blade depth
- Sawing into knots or nails in the workpiece
- Twisting the wood while making a cut
- Failing to support work
- Forcing a cut
- Cutting warped or wet lumber
- Using the wrong blade for the type of cut
- Not following correct operating procedures
- Misusing the saw
- Failing to use the anti-kickback pawls
- Cutting with a dull, gummed-up, or improperly set blade

AVOIDING KICKBACK

- Always use the correct blade depth setting. The top of the blade teeth should clear the workpiece by 1/8 in. to 1/4 in.
- Inspect the work for knots or nails before beginning a cut. Knock out any loose knots with a hammer. Never saw into a loose knot or nail.
- Always use the rip fence when rip cutting and the miter gage when cross cutting. This helps prevent twisting the wood in the cut.
- Always use clean, sharp, and properly-set blades. Never make cuts with dull blades.
- To avoid pinching the blade, support the work properly before beginning a cut.

- When making a cut, use steady, even pressure. Never force cuts.
- Do not cut wet or warped lumber.
- Always hold your workpiece firmly with both hands or with pushsticks. Keep your body in a balanced position to be ready to resist kickback should it occur. Never stand directly in line with the blade.
- Use the right type of blade for the cut being made.
- Use the blade guard assembly for all through cuts.

CUTTING AIDS

See Figure 56.

Pushsticks are devices used for safely pushing a workpiece through the blade instead of using your hands. They can be made in various sizes and shapes from scrap wood to use in a specific project. The stick must be narrower than the workpiece, with a 90° notch in one end and shaping for a grip on the other end.

A pushblock has a handle fastened by recessed screws from the underside. Use on non-through cuts.

CAUTION: Be sure the screw is recessed to avoid damaging the saw or workpiece.

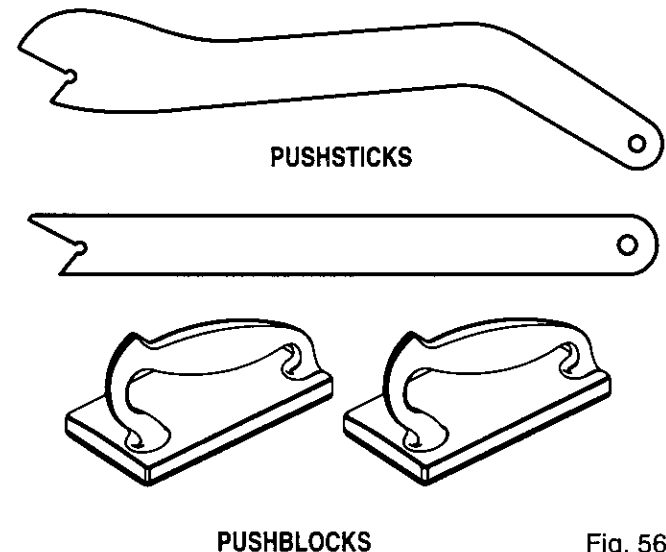

Fig. 56

A featherboard is a device used to help control the workpiece by guiding it securely against the table or fence. Featherboards are especially useful when ripping small workpieces and for completing non-through cuts. The end is angled, with a number of short kerfs to give a friction hold on the workpiece. Lock it in place on the table with a C-clamp. Test that it could resist kickback.

WARNING: Place the featherboard against the uncut portion of the workpiece, to avoid kickback that could cause serious personal injury.

OPERATION

RESETTING THE THERMAL OVERLOAD PROTECTOR

See Figure 57.

Your table saw is equipped with an overload protector to shut off the saw when a power circuit limit is reached and the motor temperature begins to rise. Otherwise, overheating can occur and cause poor performance, machine damage or fire. Be prepared to deal with overload should it occur, first in the immediate situation and then in locating the cause.

If the motor overheats, the overload protector shuts down the power. Use the steps listed below to restart.

- Turn the switch off to eliminate any possibility of the blade restarting when the motor has cooled. Remove any objects, including the workpiece, from contact with the blade to prevent binding when you do restart operation.

⚠ WARNING: If the overload protector shuts off, immediately turn the saw switch off and remove anything contacting the blade to prevent the risk of injury. When the motor cools off, it could unexpectedly restart the blade, throwing an object or cutting your hand if you are touching the blade.

- Allow time for the motor to cool. You may have to let the motor cool for as long as it had run before the protector shut it down.
- While the motor is cooling, refer to the section below to try to determine the reason for overload. Correct the problem before resuming operation.
- Press hard on the red button on the end of the motor (opposite end from the pulley). If the motor has cooled enough, you will hear a click. If you do not hear a click, let the motor cool longer.
- When you hear the click, the motor has been reset and you can continue your project.

EXTENSION CORD LENGTH	AWG WIRE SIZE FOR	
	110-120V	220-240V
0-25 ft	14	18
26-50 ft.	12	18

CAUSES OF OVERLOAD

Overload and overheating result from a number of sources. Always check the connections, the load and the supply circuit if motor performance is not satisfactory. Check wire sizes and length in the chart below. Refer to the Electrical page and check your work area for problem conditions such as the following:

- Loose or incorrect connections (see *Connecting the Motor* and *Changing the Motor Voltage* in the Assembly section)
- Wrong type of plug (use only 3-prong grounding type) or receptacle (matching receptacle for 3-prong plug)
- Reduced input voltage (too small a wire or too many items on the circuit)
- Extension cord is too long or wrong type (use only outdoor extension cords sized by the chart.)
- Using a dull blade or forcing a cutting operation.

⚠ WARNING: Use the correct cord and plug to prevent overload and motor burnout.

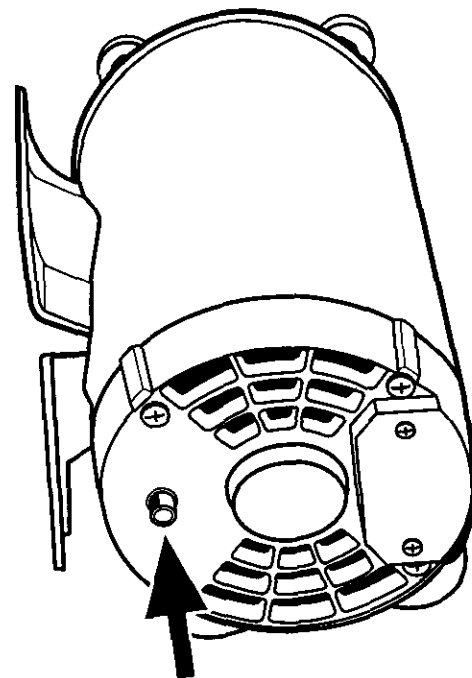

MOTOR RESET BUTTON

Fig. 57

Note: This motor should be blown out or vacuumed frequently to prevent saw dust build-up which could interfere with motor cooling.

OPERATION

TYPES OF CUTS

See Figure 58.

There are six basic cuts: 1) the cross cut, 2) the rip cut, 3) the miter cut, 4) the bevel cross cut, 5) the bevel rip cut, and 6) the compound (bevel) miter cut. All other cuts are combinations of these basic operations. Operating procedures for making each kind of cut are given later in this section.

⚠ WARNING: Always make sure the blade guard and anti-kickback pawls are in place and working properly when making these cuts to avoid possible injury.

Cross cuts are straight 90° cuts made across the grain of the workpiece. The wood is fed into the cut at a 90° angle to the blade, and the blade is vertical.

Rip cuts are made with the grain of the wood. To avoid kickback while making a rip cut, make sure one side of the wood rides firmly against the rip fence.

The rip fence features a micro-adjust knob, which allows for precise adjustments of the rip fence and fine tolerances in the woodwork.

Miter cuts are made with the wood at any angle to the blade other than 90°. The blade is vertical. Miter cuts tend to “creep” away from the miter fence during cutting. This can be controlled by holding the workpiece securely against the miter fence.

⚠ WARNING: Always use a push stick with small pieces of wood, and also to finish the cut when ripping a long narrow piece of wood, to prevent your hands from getting close to the blade.

Bevel cuts are made with an angled blade. Bevel cross cuts are across the wood grain, and bevel rip cuts are with the grain. The rip fence must always be on the right side of the blade for bevel rip cuts.

Compound (or bevel) miter cuts are made with an angled blade on wood that is angled to the blade. Be thoroughly familiar with making straight cross cuts, rip cuts, bevel cuts, and miter cuts before trying a compound miter cut.

⚠ WARNING: All blades and cutting accessories must be rated for at least 5,000 rpm to prevent possible injury.

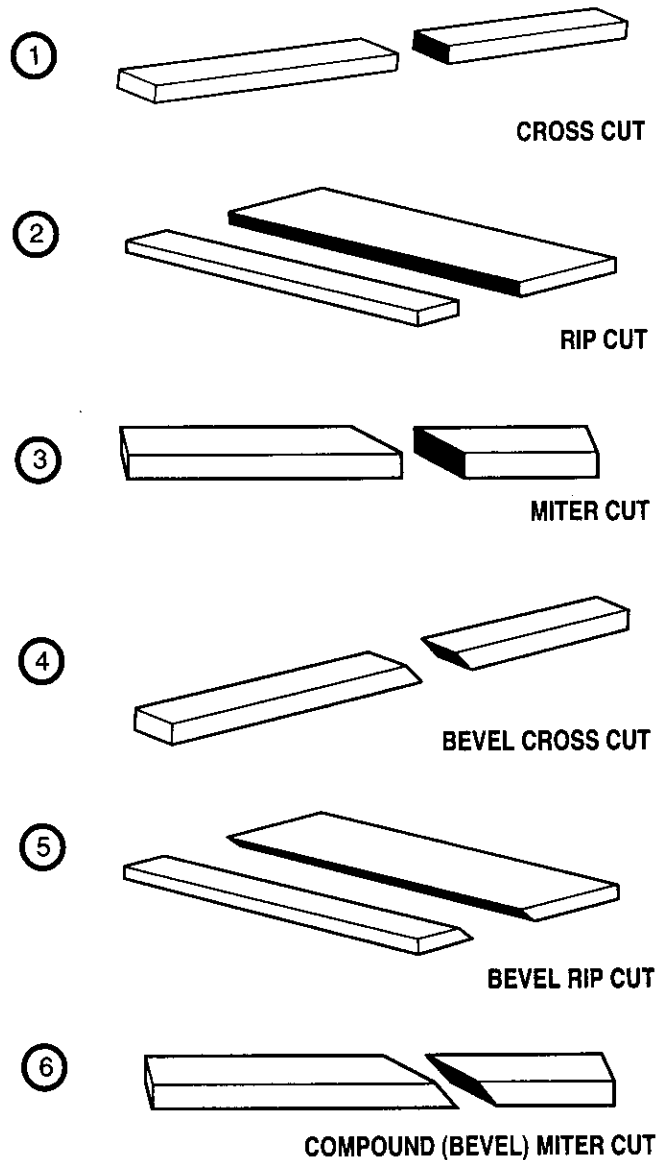

Fig. 58

OPERATION

MAKING A CROSS CUT

See Figures 59, 60, 61, and 62.

⚠ WARNING: Make sure the blade guard is lowered over the blade and is working properly to prevent possible injury.

It is recommended that you make test cuts on scrap wood. Stand at the front of the saw and push the wood with the miter gage.

- Set blade to the right depth for workpiece by turning height handwheel.
- Set the miter gage to 0. See Figure 59. Make sure miter gage knob is securely tightened.
- Place a support the same height as top of saw table behind the saw for cut work.
- The miter gage may be used in either of the two grooves in the table. When using left groove, hold workpiece firmly against the miter gage base with your left hand and grip the knob with your right hand. When using right groove, hold workpiece firmly against the miter gage base with your right hand and grip the knob with your left hand. See Figure 59.

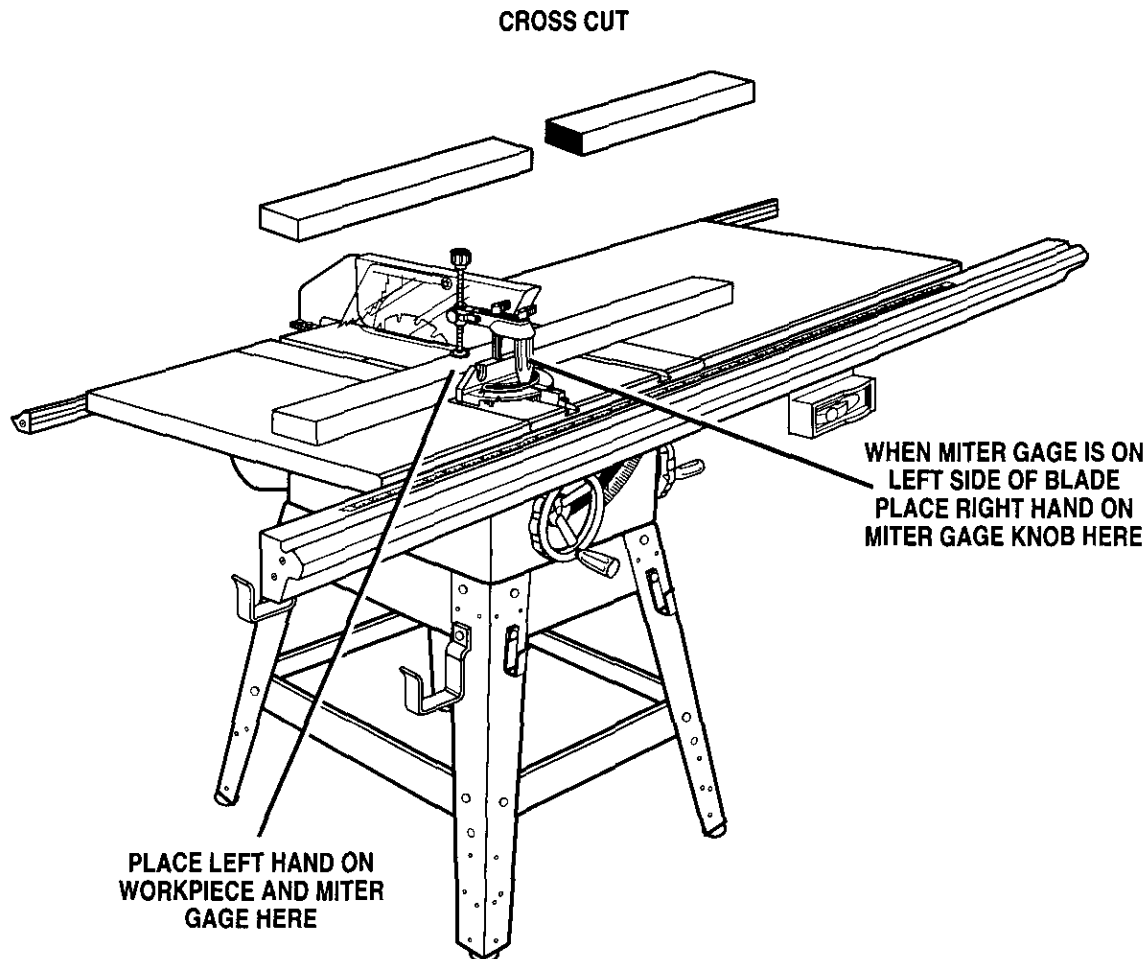
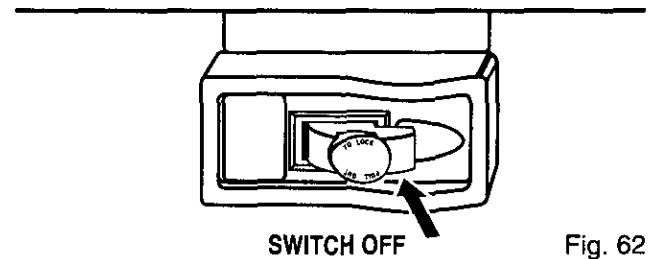
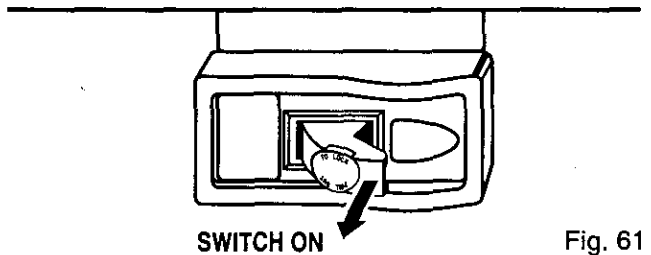
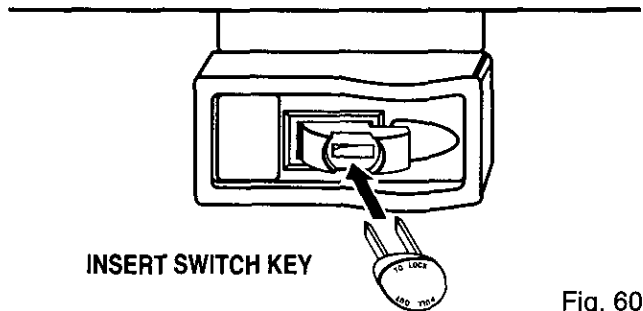

Fig. 59

OPERATION

- Check that the wood is not touching the blade. Insert switch key and lift switch to **ON** position. See *Figures 60 and 61*.
- Let blade obtain full speed before feeding workpiece into the blade with the miter gage.
- Hold work firmly against miter gage and push miter gage to feed work into the blade.
- When work is completed, press switch off and remove switch key. See *Figure 62*.

MAKING A RIP CUT

See *Figure 63*.

Making a test cut on scrap wood is highly recommended. From the front of the saw, position the wood against the rip fence and push it to the blade with a pushstick. Be sure the end of the wood is square.

⚠ WARNING: NEVER stand directly in the line of cut. Stand to the side to reduce risk of injury.

⚠ WARNING: NEVER push a small piece of wood into the blade with your hand.

⚠ WARNING: Make sure the blade guard is lowered over the blade and is working properly to prevent possible injury.

- Remove miter gage and attach rip fence over rails.
- Place a support the same height as top of saw table behind the saw for cut work.
- Position rip fence the correct distance from blade for cut.
- For small pieces of wood, use a pushstick to move wood into and past blade.
- Make sure wood is not touching blade. Insert switch key and lift switch to **ON** position. Let blade obtain full speed before feeding workpiece into the blade.
- When work is completed, press switch off and remove switch key.

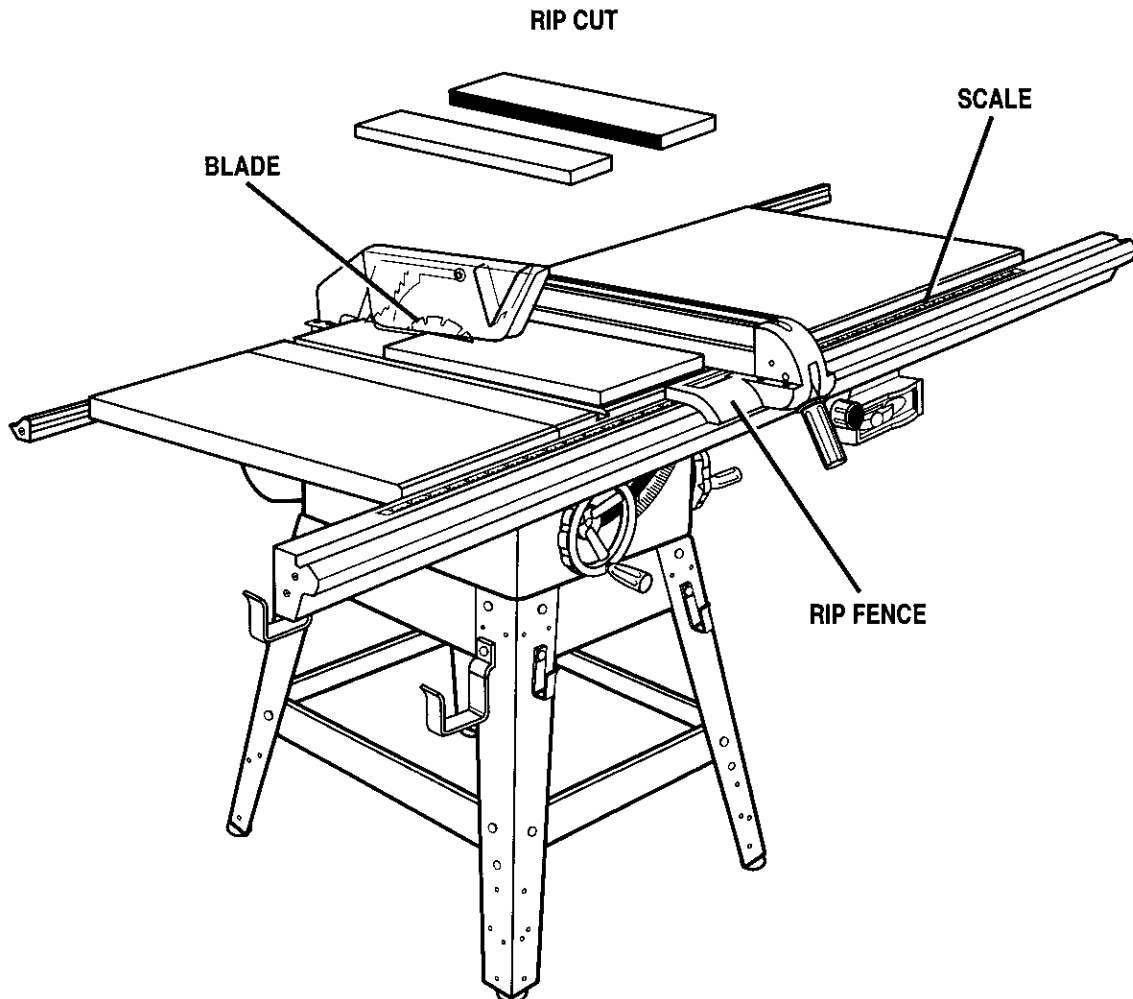

Fig. 63

OPERATION

MAKING A MITER CUT

See Figure 64.

WARNING: Make sure the blade guard is lowered over the blade and is working properly to prevent possible injury.

Make a test cut on scrap wood. From the front of the saw, push the wood to the blade with the miter gage. The miter gage may be used in either of the grooves. When using the left groove, hold the workpiece firmly against the miter gage base with your left hand and grip the miter gage knob with your right hand. When using the right groove, hold the work piece with your right hand and the miter gage knob with your left hand.

- Check that the blade is at the correct height for the workpiece. To change the blade height, turn the height handwheel.
- If blade is not at 90° to the table, loosen bevel lock handle and turn bevel handwheel. Reset bevel lock handle.
- To set the wood angle, loosen miter gage knob, set the angle with the indicator on the miter gage, then retighten miter gage knob.
- Place a support the same height as top of saw table behind the saw for cut work.
- Make sure wood is not touching the blade before turning on the saw. Insert switch key and lift switch to **ON** position. Let the blade obtain full speed before moving the miter gage to feed the workpiece into the blade.

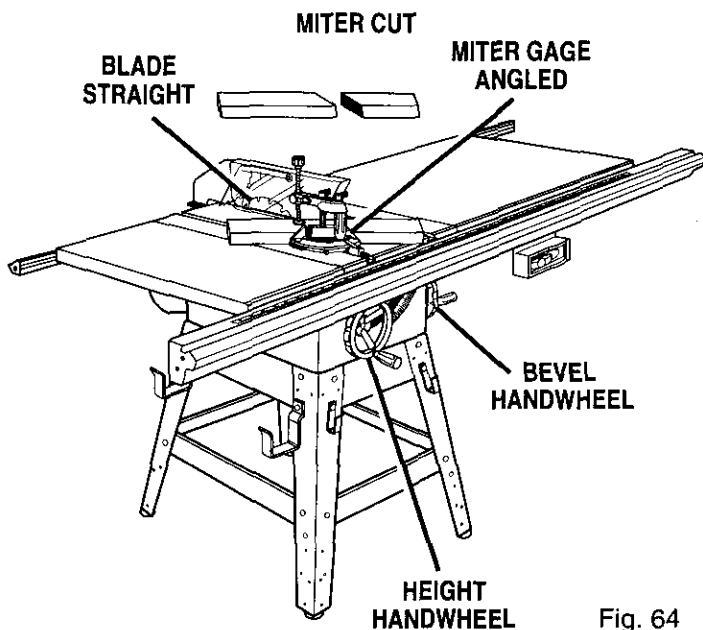

Fig. 64

- Hold work firmly against the miter gage and push to feed work into the blade.
- When work is completed, press switch off and remove switch key.

MAKING A BEVEL CROSS CUT

See Figures 65 and 66.

WARNING: Make sure the blade guard is lowered and is working properly to prevent possible injury.

Make a test cut on scrap wood. From the front of the saw, push the wood to the blade with the miter gage. When using the miter gage in the left groove, hold the workpiece firmly against the miter gage base with your left hand and grip the miter gage knob with your right hand. When using the right groove, hold the work piece with your right hand.

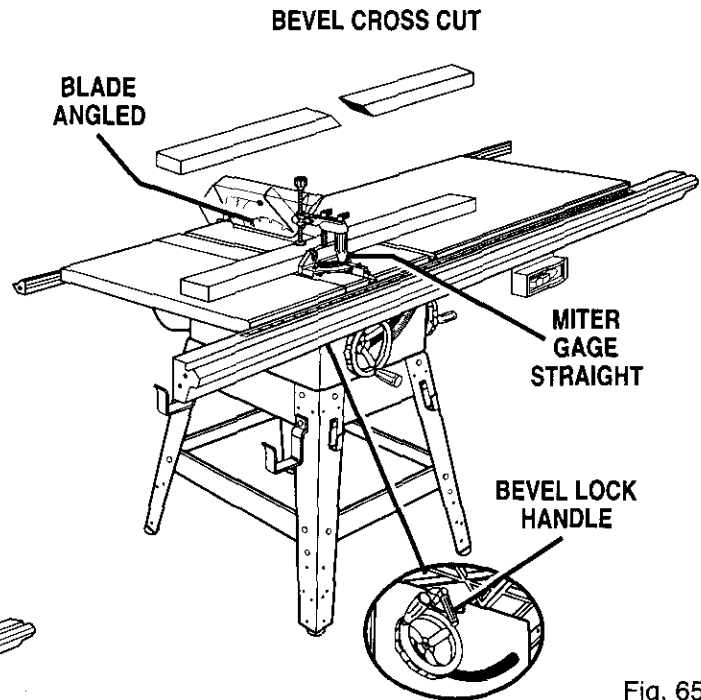

Fig. 65

- Raise rip fence handle and remove rip fence.
- Set blade angle by loosening bevel lock handle and turning bevel handwheel until scale on the cabinet front reads desired angle. Retighten bevel lock handle.

OPERATION

- Set miter gage to 0° if needed. Loosen miter gage knob and use indicator on the miter gage. Retighten miter gage knob.
- Place a support the same height as top of saw table behind the saw for cut work.
- Make sure wood is clear of blade before turning on saw. Insert switch key and lift switch to **ON** position. Let blade obtain full speed before feeding wood into blade with miter gage.
- Hold the work firmly against the miter gage and push the miter gage to feed the work into the blade.
- When work is completed, press the switch off and remove the key.

- Set blade angle by loosening bevel lock handle and turning bevel handwheel. Retighten blade lock handle.

⚠ WARNING: When making a bevel rip cut, the rip fence must be on the right side of the blade. Otherwise the fence could trap the workpiece, possibly causing kickback and resulting in injury.

- Attach rip fence on the right side of the blade at correct distance from blade for cut. Use micro-adjust knob on front rail.
- Place a support the same height as the top of saw table behind the saw for the cut work.

VIEWED FROM THE FRONT, BELOW THE SAW TABLE

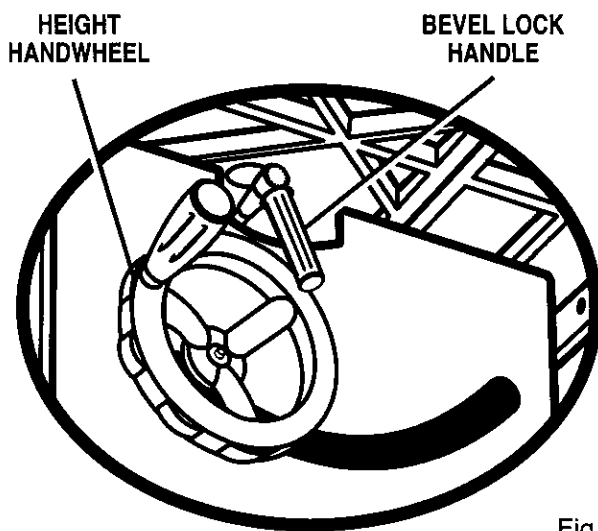

Fig. 66

MAKING A BEVEL RIP CUT

See Figures 66 and 67.

Try this cut on a piece of scrap wood before cutting your workpiece. Use a pushstick to move small pieces of wood into and past the blade.

⚠ WARNING: Make sure the blade guard is lowered and is working properly to prevent possible injury.

⚠ WARNING: NEVER stand directly in the line of cut. Stand to the side to reduce the risk of injury should kickback occur.

- Make sure wood is clear of the blade before turning on saw. Insert switch key and lift switch to **ON** position. Let blade obtain full speed before feeding workpiece into the blade.

⚠ WARNING: NEVER push a small piece of wood into the blade with your hand. Use a pushstick as the end of the workpiece nears the blade to avoid serious personal injury.

- When work is completed, press switch off and remove switch key.

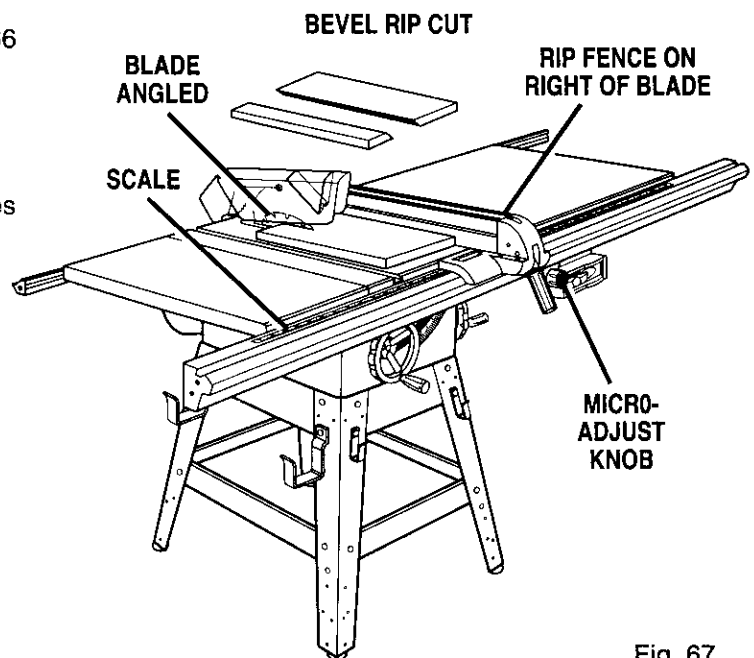

Fig. 67

OPERATION

MAKING A COMPOUND (BEVEL) MITER CUT

See Figure 68.

Practice on scrap wood. From the front of the saw, push the wood to the blade with the miter gage. Do not use the rip fence.

⚠ WARNING: Make sure the blade guard is lowered over the blade and is working properly to prevent possible injury.

⚠ WARNING: When the blade is angled to the left, the miter gage must be on the right side of the blade. Otherwise the gage could trap the workpiece, possibly causing kickback and resulting in injury.

- Set blade angle and height by loosening the bevel lock handle and turning the height and bevel handwheels. Retighten bevel lock handle.
- Set wood angle by loosening miter gage knob and setting it to desired angle.
- Retighten miter gage knob.
- Place a support the same height as top of saw table behind the saw for cut work.
- Make sure wood is not touching the blade.
- Insert switch key and lift switch to **ON** position. Let blade obtain full speed.
- Hold work firmly against miter gage with both hands and push miter gage to feed work into blade.
- When work is completed, press switch off and remove switch key.

COMPOUND (BEVEL) MITER CUT

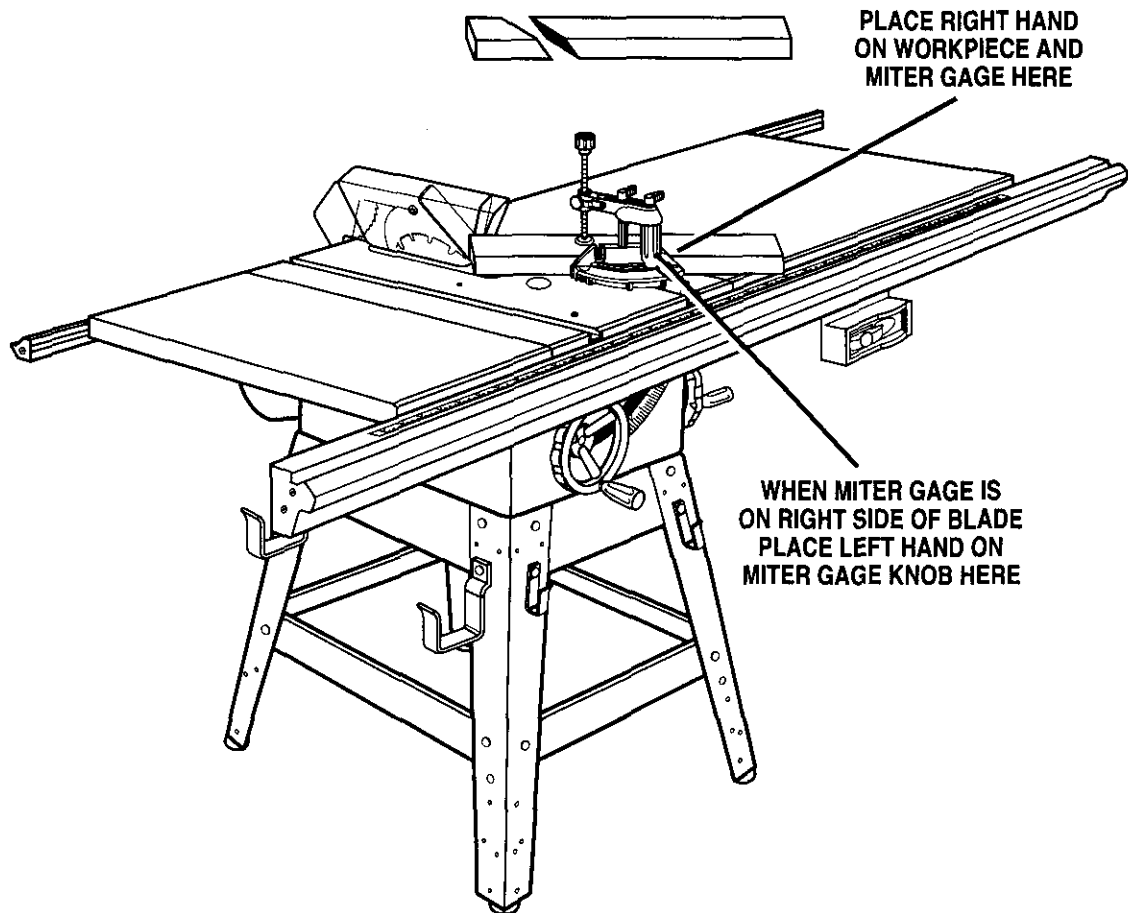

Fig. 68

OPERATION

MAKING A LARGE PANEL CUT

See Figure 69.

Make sure the saw is properly secured to a work surface to avoid tipping from the weight of a large panel.

⚠ WARNING: Make sure the blade guard is lowered over the blade and is working properly to prevent possible injury.

■ Place a support the same height as top of saw table behind the saw for cut work. Add supports to the sides as needed.

■ Depending on the shape of panel, use rip fence or miter gage. If panel is too large to use either rip fence or miter gage, it is too large for this saw.

⚠ WARNING: Never make freehand cuts (cuts without the miter gage or rip fence), which can result in serious injury.

■ Make sure wood does not touch blade before you turn on saw. Let blade obtain full speed before feeding wood into blade.

■ When work is completed, press switch off and remove switch key.

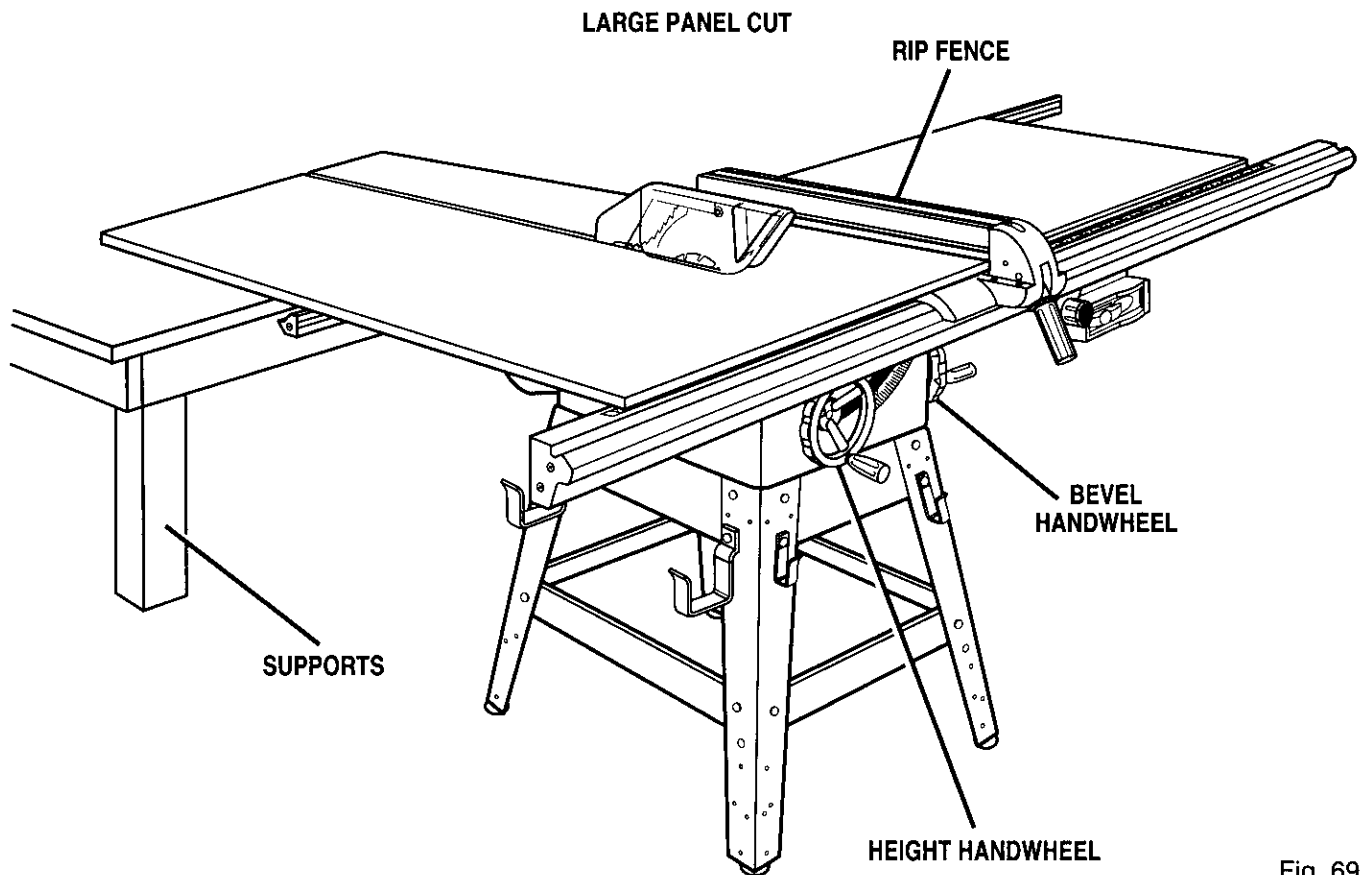

Fig. 69

OPERATION

MAKING A NON-THROUGH CUT

See Figure 70.

This is the only type of cut made without the blade guard.

- ⚠ **WARNING:** Unplug saw while removing or replacing the blade guard to prevent accidental starting and injury.
- ⚠ **WARNING:** Never put your hands within 3 in. of the blade when it is on or you could be seriously hurt.
- Lift the blade guard out of the way.
- Adjust blade angle and height by releasing bevel lock handle and turning height and bevel handwheels. Reset bevel lock handle.
- Remove riving knife and guard assembly as shown. Take out throat plate by removing the screw with a phillips screwdriver. Be sure to reinstall throat plate before moving to the next step.
- Place a support the same height as top of saw table behind the saw for cut work. Add supports to the sides as needed.
- ⚠ **WARNING:** Always use pushsticks or pushblocks when making non-through cuts to avoid the risk of serious injury. Never feed wood with your hands.
- Make sure wood is not touching blade. Insert switch key and lift switch to **ON** position. Let the blade obtain full speed before feeding workpiece into blade.
- When the work is completed, press the switch off and remove the key. Unplug the saw, reinstall the riving knife, and blade guard.

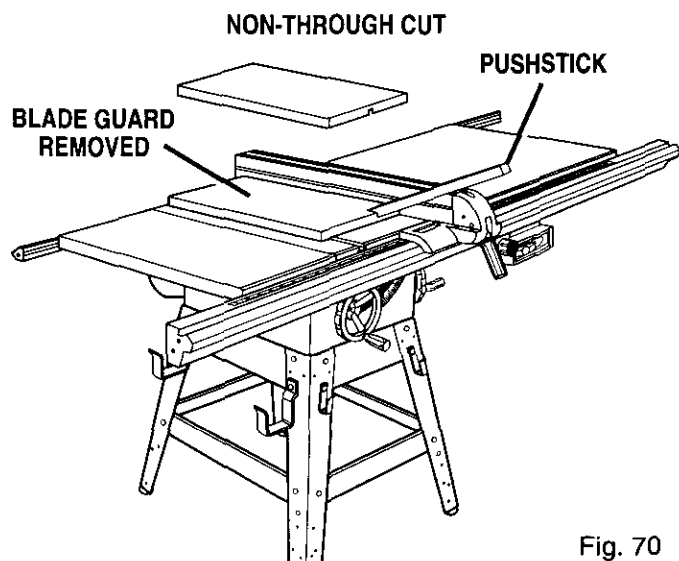

Fig. 70

MAKING A DADO CUT

See Figure 71.

An optional dado throat plate is required for this procedure. See the *Accessories* section of this manual and check with your nearest Sears Retail Store. All blades and dado sets must be rated at least 5,000 RPM.

- ⚠ **WARNING:** Unplug saw before working around the blade. Accidental starting could cause serious injury.
- Take out throat plate by removing the screw.
- Remove riving knife and blade guard assembly. Remove the blade.
- Mount dado blade according to instructions provided with it.
- Test blade nut and blade washer tightness.
- Install optional dado throat plate.
- Plug in saw and follow dado instructions. Always use pushsticks with dado cuts.
- Make sure wood does not touch the blade before you turn on saw. Let blade obtain full speed before feeding wood into the blade.
- When the work is completed, press the switch off and remove the key. Unplug the saw, remove the dado insert and dado blade. Reinstall the blade, riving knife, blade guard and throat plate.

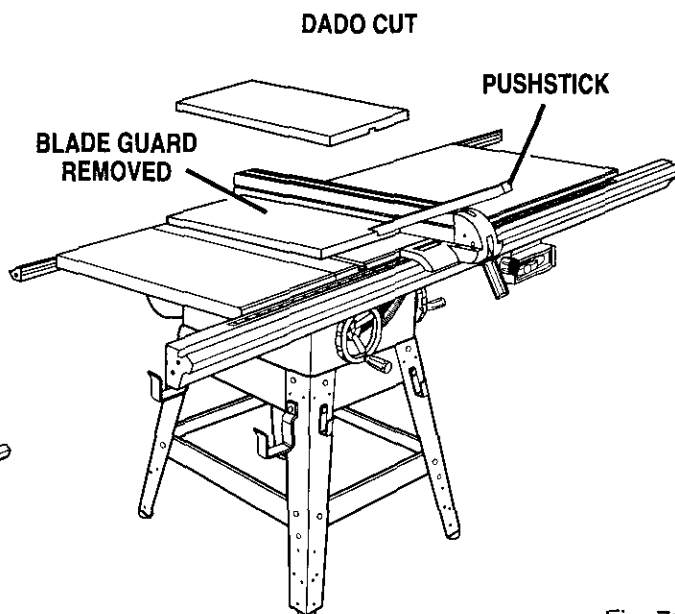

Fig. 71

MAINTENANCE

GENERAL MAINTENANCE

⚠ WARNING: When servicing, use only identical Craftsman replacement parts. Use of any other part may create a hazard or cause product damage.

⚠ WARNING: To prevent accidental starting that could cause possible serious personal injury, turn off the saw, remove the switch key, and unplug the saw before working on the table saw.

- Remove sawdust from the rails, top surface, and inside of saw frequently.
- Clean plastic parts with a soft damp cloth. Do not use any strong solvents.

⚠ WARNING: Do not at any time let brake fluids, gasoline, petroleum-based products, penetrating oils, etc. contact plastic parts. They contain chemicals that can damage, weaken or destroy plastic.

- Periodically clean the table, rails, and rip fence with gum and pitch remover. Do not allow pitch to accumulate on the saw.
- Apply a thin coat of paste wax to the table top so the wood slides easily while cutting.
- Regularly check all nuts, bolts, screws, and belts for tightness and condition. Make sure the throat plate is in good condition.

MOTOR / ELECTRICAL

- Frequently vacuum or blow out any sawdust from the motor.

⚠ WARNING: If the power cord is worn, cut, or damaged in any way, have it replaced immediately by a qualified service technician at a Sears store or repair center. Failure to do so could result in serious personal injury.

⚠ WARNING: To avoid fire or electrocution, reassemble electric parts with only identical Craftsman replacement parts. Reassemble exactly as originally assembled.

LUBRICATION

This saw has been lubricated at the factory prior to shipment. After extended use, you should inspect, clean, and lubricate the areas shown in the drawing. Clean before lubricating with a solvent recommended for gum and pitch removal. Lubricate with SAE no. 20 or no. 30 engine oil.

See Figure 72.

- Table brackets. (a)
- Bevel handwheel rod threads and knuckle. (b)
- Height handwheel threads and trunnion. (c)

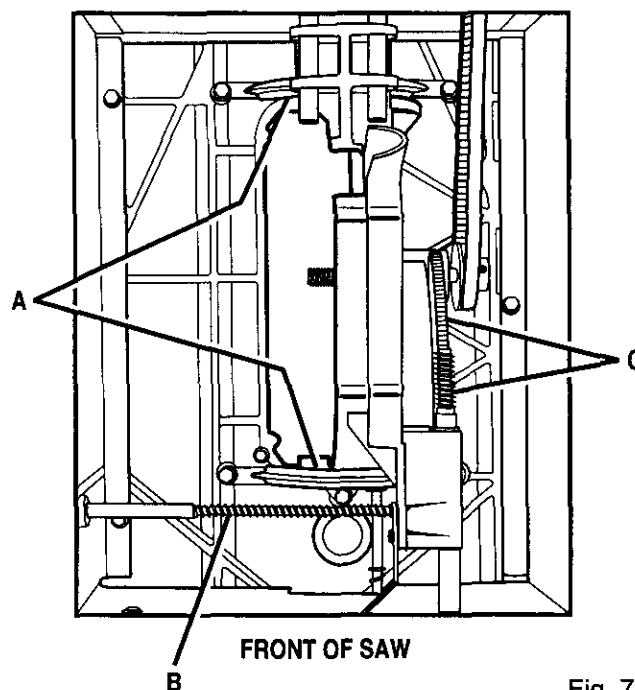

Fig. 72

TROUBLESHOOTING

PROBLEM	CAUSE	SOLUTION
Saw does not start.	<ol style="list-style-type: none"> 1. Motor cord or wall cord is not plugged in. 2. Circuit fuse is blown. 3. Circuit breaker is tripped. 4. Cord or switch is damaged. 	<ol style="list-style-type: none"> 1. Plug in motor cord or wall cord. 2. Replace circuit fuse. 3. Reset circuit breaker. 4. Have the cord or switch replaced at your nearest Sears Service Center.
Saw is noisy when running.	<ol style="list-style-type: none"> 1. Motor needs attention. 	<ol style="list-style-type: none"> 1. Have the motor checked at your nearest Sears Service Center.
Motor is slow or weak.	<ol style="list-style-type: none"> 1. Voltage from source is low. 2. Windings are burned out or open. 3. Start switch is defective. 4. Circuit is overloaded with appliances, lights, or other motors. 5. May be wired for 240 volts instead of 120 volts. 	<ol style="list-style-type: none"> 1. Request a voltage check from the power company. 2. Have the motor checked at your nearest Sears Service Center. 3. Have the switch replaced. 4. Do not use other appliances or motors on the same circuit when using the saw. 5. Check wiring of the saw with info and diagrams in <i>Changing the motor voltage</i> in the <i>Assembly Section</i>.
Motor overheats.	<ol style="list-style-type: none"> 1. Motor is overloaded. 2. Dull blade. 3. Sawdust inside saw is blocking air flow. 	<ol style="list-style-type: none"> 1. Request a voltage check from the power company. 2. Replace the blade. 3. Clean out the saw base.
Motor stalls, blows fuses, or trips circuit breakers.	<ol style="list-style-type: none"> 1. Starter switch is defective. 2. Voltage from source is low. 3. Dull blade. 4. Fuses or circuit breakers are wrong size or defective. 5. Feeding workpiece too rapidly. 	<ol style="list-style-type: none"> 1. Have the switch replaced. 2. Request a voltage check from the power company. 3. Replace the blade. 4. Replace fuses or circuit breakers. 5. Feed workpiece into blade slower.



TROUBLESHOOTING

PROBLEM	CAUSE	SOLUTION
Fuses or circuit breakers open frequently.	<ol style="list-style-type: none"> 1. Motor is overloaded. 2. Fuses or circuit breakers are wrong size or defective. 3. Dull blade. 4. Start switch is defective. 	<ol style="list-style-type: none"> 1. Feed work more slowly. 2. Replace fuses or circuit breakers. 3. Replace the blade. 4. Have the switch replaced.
Saw vibrates excessively.	<ol style="list-style-type: none"> 1. Blade is warped. 2. Belt is damaged. 3. Saw is not mounted securely. 4. Work surface is uneven. 	<ol style="list-style-type: none"> 1. Replace the blade. 2. Replace the belt. 3. Tighten all hardware. 4. Reposition on a flat surface. Adjust the leveling feet on legs.
Start switch does not operate.	<ol style="list-style-type: none"> 1. Switch contacts are burned out. 2. Capacitor is defective 3. Connections are loose or damaged. 	<ol style="list-style-type: none"> 1. Have the switch replaced and request a voltage check from the power company. 2. Have the capacitor replaced. 3. Have the wiring checked and repaired.
Handwheels are hard to turn.	<ol style="list-style-type: none"> 1. Sawdust has collected on the mechanism inside saw. 	<ol style="list-style-type: none"> 1. Clean and lubricate the mechanism.
Blade does not lower when turning height handwheel.	<ol style="list-style-type: none"> 1. Blade lock handle is not fully released. 	<ol style="list-style-type: none"> 1. Fully release the blade lock handle.
Miter gage does not move smoothly.	<ol style="list-style-type: none"> 1. Miter gage assembly is dirty or sticky. 	<ol style="list-style-type: none"> 1. Release the miter gage knob and wax the miter gage base and sides.
Cut binds, burns or stalls motor when ripping.	<ol style="list-style-type: none"> 1. Blade or teeth are dull. 2. Blade is heeling. 3. Board is warped. 4. Rip fence does not parallel blade. 	<ol style="list-style-type: none"> 1. Sharpen or replace the blade. 2. See <i>Heeling the Sawblade</i> in the <i>Adjustments</i> section. 3. Replace the board. 4. See <i>Aligning the Rip Fence</i> in the <i>Assembly</i> section.
Saw blade does not cut true at 90° or 45° positions.	<ol style="list-style-type: none"> 1. Indicators are not properly adjusted. 2. Positive stops inside base are not accurate. 	<ol style="list-style-type: none"> 1. See <i>Setting the Bevel Stops and Indicator</i> in the <i>Adjustments</i> section. 2. See <i>Setting the Bevel Stops and Indicator</i> in the <i>Adjustments</i> section.



TROUBLESHOOTING

PROBLEM	CAUSE	SOLUTION
Rip fence does not move smoothly.	<ol style="list-style-type: none">1. Rip fence is not mounted correctly.2. Rails are dirty or sticky.	<ol style="list-style-type: none">1. Remove and reposition the rip fence. See <i>Aligning Rip Fence and Front Rail</i> in the <i>Assembly</i> section.2. Clean and wax the rails.
Wood edges away from rip fence when ripping.	<ol style="list-style-type: none">1. Rip fence is misaligned.	<ol style="list-style-type: none">1. See the <i>Assembly</i> section for <i>Checking Rip Fence and Blade Alignment</i> and <i>Aligning Rip Fence and Front Rail</i> procedures.

CRAFTSMAN TABLE SAW – MODEL NO. 315.228590

The model number will be found on a plate attached to the cabinet. Always mention the model number in all correspondence regarding your **TABLE SAW** or when ordering repair parts.

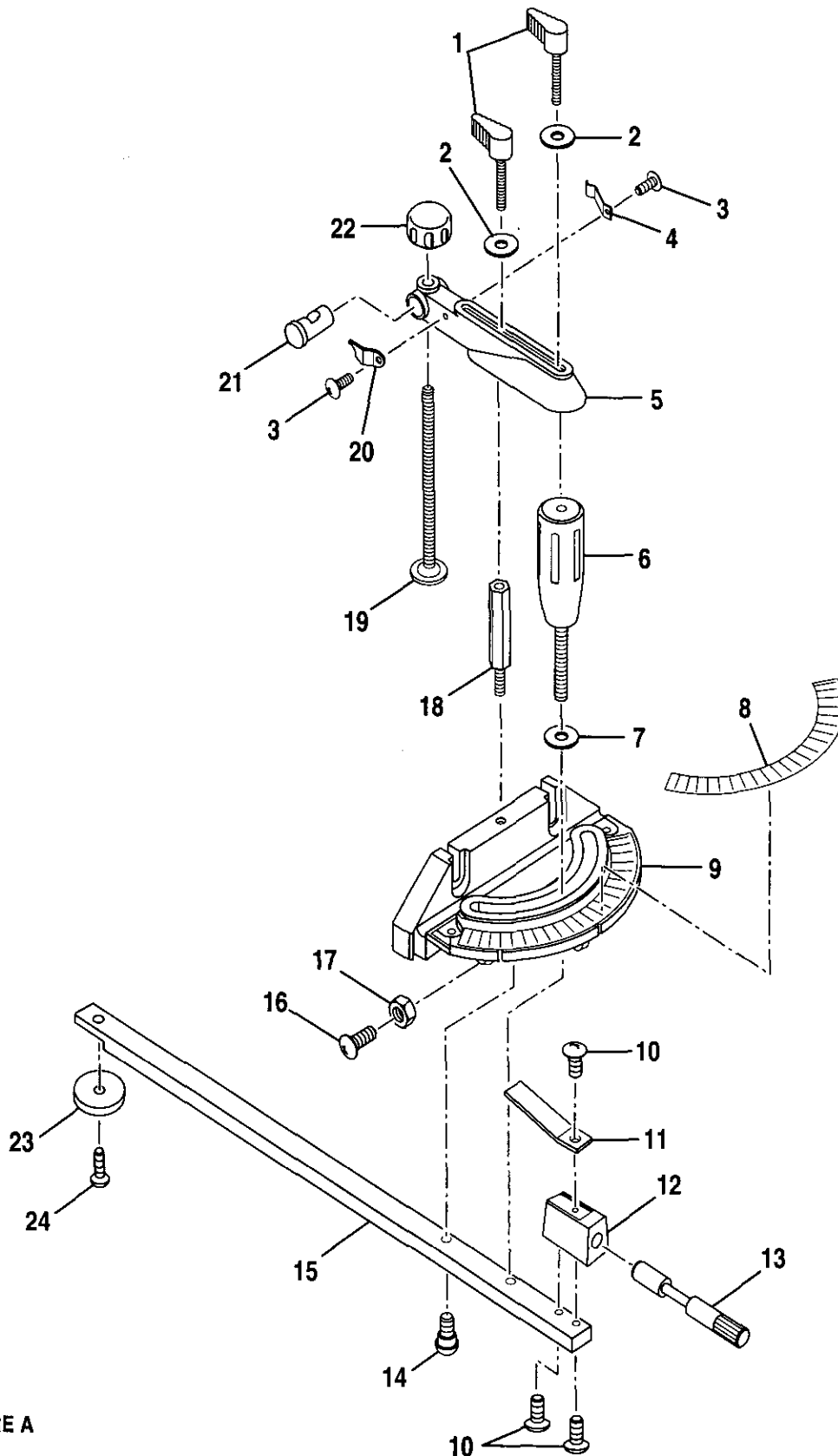

FIGURE A



CRAFTSMAN TABLE SAW – MODEL NO. 315.228590

The model number will be found on a plate attached to the cabinet. Always mention the model number in all correspondence regarding your **TABLE SAW** or when ordering repair parts.

PARTS LIST FOR FIGURE A

Key No.	Part Number	Description	Quan.
1	980673-002	Knob Assembly	2
2	** STD551025	* Washer (1/4 in.)	2
3	982289-001	* Screw (#8-32 x 3/8 in.)	2
4	980679-001	Spring	1
5	980677-001	Clamp Housing	1
6	980672-002	Miter Gage Knob	1
7	** STD551031	* Washer (5/16 in.)	1
8	982277-001	Miter Scale Label	1
9	982119-001	Miter Gage	1
10	** STD511003	* Screw (#10-24 x 3/8 in.)	3
11	979978-001	Miter Scale Indicator	1
12	979979-001	Miter Gage Block	1
13	979980-001	Stop Pin	1
14	979984-001	Shoulder Screw	1
15	979981-002	Miter Gage Rod	1
16	** STD510807	* Screw (#8-32 x 5/8 in.)	3
17	** STD541008	* Hex Nut (#8-32)	3
18	980675-001	Spacer	1
19	980680-001	Clamp Screw	1
20	980678-001	Lock Tab	1
21	980674-001	Quick Release Button	1
22	980676-002	Knob	1
23	982087-001	Sliding Washer	1
24	982088-001	* Screw (1/4-20 x 1/4 in. Flat Hd.)	1
	981286-001	Miter Gage Assembly (Includes Key Nos. 1-24)	1

* Standard Hardware Item — May Be Purchased Locally
 ** Available From Div. 98 — Source 980.00



CRAFTSMAN TABLE SAW – MODEL NO. 315.228590

The model number will be found on a plate attached to the cabinet. Always mention the model number in all correspondence regarding your **TABLE SAW** or when ordering repair parts.

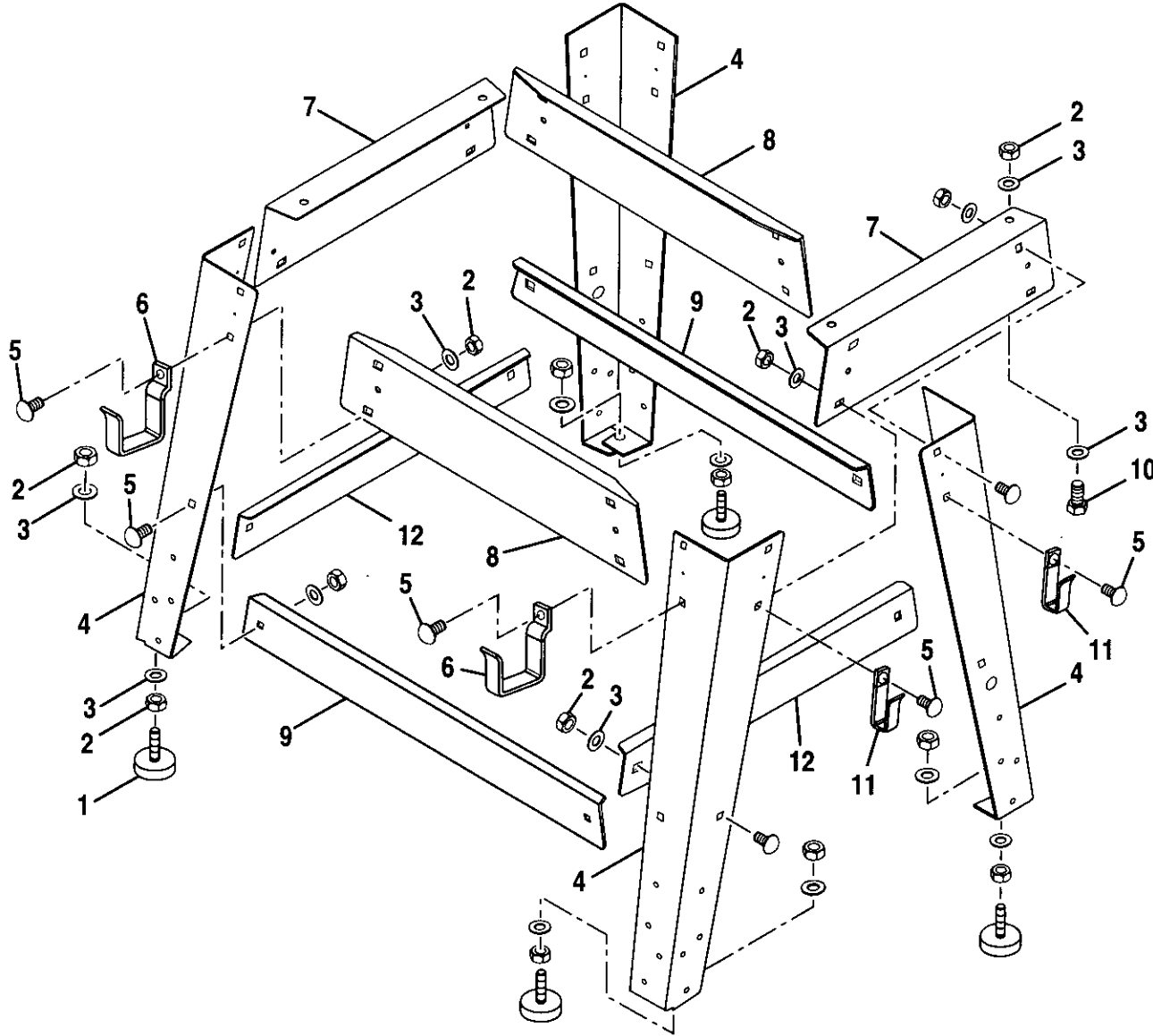

FIGURE B

CRAFTSMAN TABLE SAW – MODEL NO. 315.228590

The model number will be found on a plate attached to the cabinet. Always mention the model number in all correspondence regarding your **TABLE SAW** or when ordering repair parts.

PARTS LIST FOR FIGURE B

Key No.	Part Number	Description	Quan.
1	979999-001	Leveling Foot.....	4
2	** STD541031	* Hex Nut (5/16-18)	36
3	** STD551031	* Washer (5/16 in.).....	40
4	979995-002	Leg	4
5	** STD533107	* Carriage Bolt (5/16-18 x 3/4 in.)	24
6	982273-001	Large Storage Hanger	2
7	979993-002	End Brace	2
8	979997-002	Side Brace	2
9	979998-002	Long Leg Brace	2
10	** STD523107	* Bolt (5/16-18 x 3/4 in. Hex Hd.)	4
11	982274-001	Small Storage Hanger.....	2
12	979996-002	Short Leg Brace	2

* Standard Hardware Item — May Be Purchased Locally
 ** Available From Div. 98 — Source 980.00



CRAFTSMAN TABLE SAW – MODEL NO. 315.228590

The model number will be found on a plate attached to the cabinet. Always mention the model number in all correspondence regarding your **TABLE SAW** or when ordering repair parts.

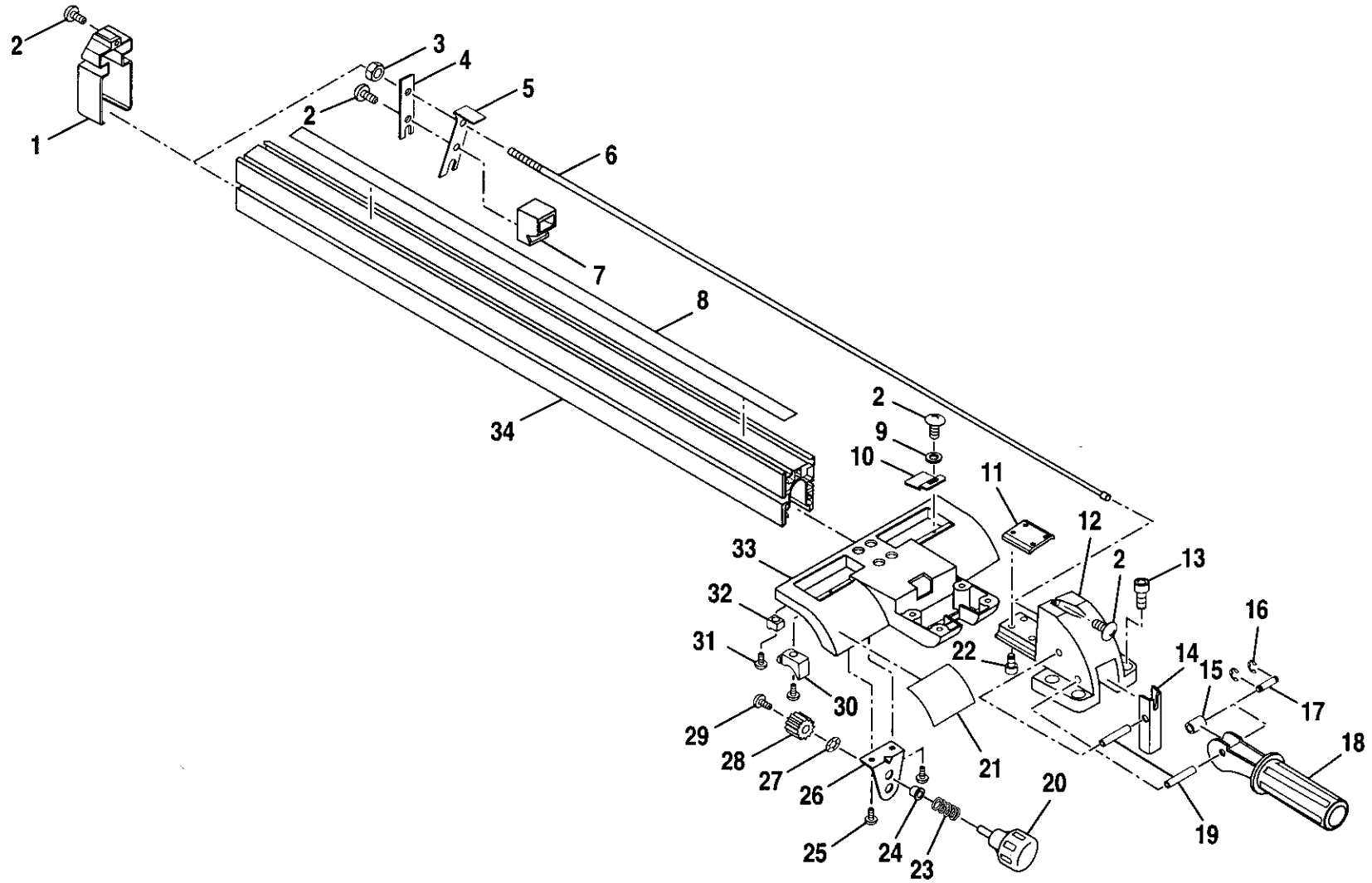

FIGURE C



CRAFTSMAN TABLE SAW – MODEL NO. 315.228590

The model number will be found on a plate attached to the cabinet. Always mention the model number in all correspondence regarding your **TABLE SAW** or when ordering repair parts.

PARTS LIST FOR FIGURE C

Key No.	Part Number	Description	Quan.	Key No.	Part Number	Description	Quan.
1	980681-001	Fence End Cap	1	19	980688-001	Roll Pin (8 x 60 mm)	2
2	979945-001	* Screw (#8-32 x 1/2 in.)	4	20	980953-002	Fence Adjustment Knob	1
3	** STD541425	* Lock Nut (1/4-20)	1	21	980322-001	Warning Label	1
4	979970-001	Lock Plate	1	22	979967-001	* Screw (1/4-20 x 3/4 in. Socket Hd.)	4
5	979969-001	Lock Spring	1	23	980952-001	Spring	1
6	979968-001	Fence Lock Rod	1	24	980951-001	Bushing	1
7	979972-001	Rear Fence Slide	1	25	** STD512503	* Screw (1/4-20 x 3/8 in.)	2
8	980319-001	Fence Label	1	26	980949-001	Fence Adjusting Bracket	1
9	** STD551008	* Washer (#8)	1	27	980948-001	Push Nut	1
10	979961-001	Scale Indicator	1	28	980684-001	Gear	1
11	979962-001	Fence Plate	1	29	980945-001	* Screw (#10-24 x 3/8 in.)	1
12	980683-001	Rip Fence Cover	1	30	980966-001	Rear Glide	2
13	979881-001	* Screw (5/16-18 x 1/2 in. Socket Hd.)	4	31	980598-001	* Screw (#8-32 x 1/4 in.)	4
14	979964-001	Fence Handle Bracket	1	32	980965-001	Front Glide	2
15	980964-001	Cam Sleeve	1	33	980685-001	Scale Indicator Housing	1
16	980596-001	Retaining Ring	2	34	980682-001	Rip Fence	1
17	980595-001	Pin	1		981283-001	Complete Rip Fence Assembly	1
18	979965-002	Rip Fence Handle	1		981280-001	Complete Micro Adjust Assembly	1

* Standard Hardware Item — May Be Purchased Locally
 ** Available From Div. 98 — Source 980.00



CRAFTSMAN TABLE SAW – MODEL NO. 315.228590

The model number will be found on a plate attached to the cabinet. Always mention the model number in all correspondence regarding your TABLE SAW or when ordering repair parts.

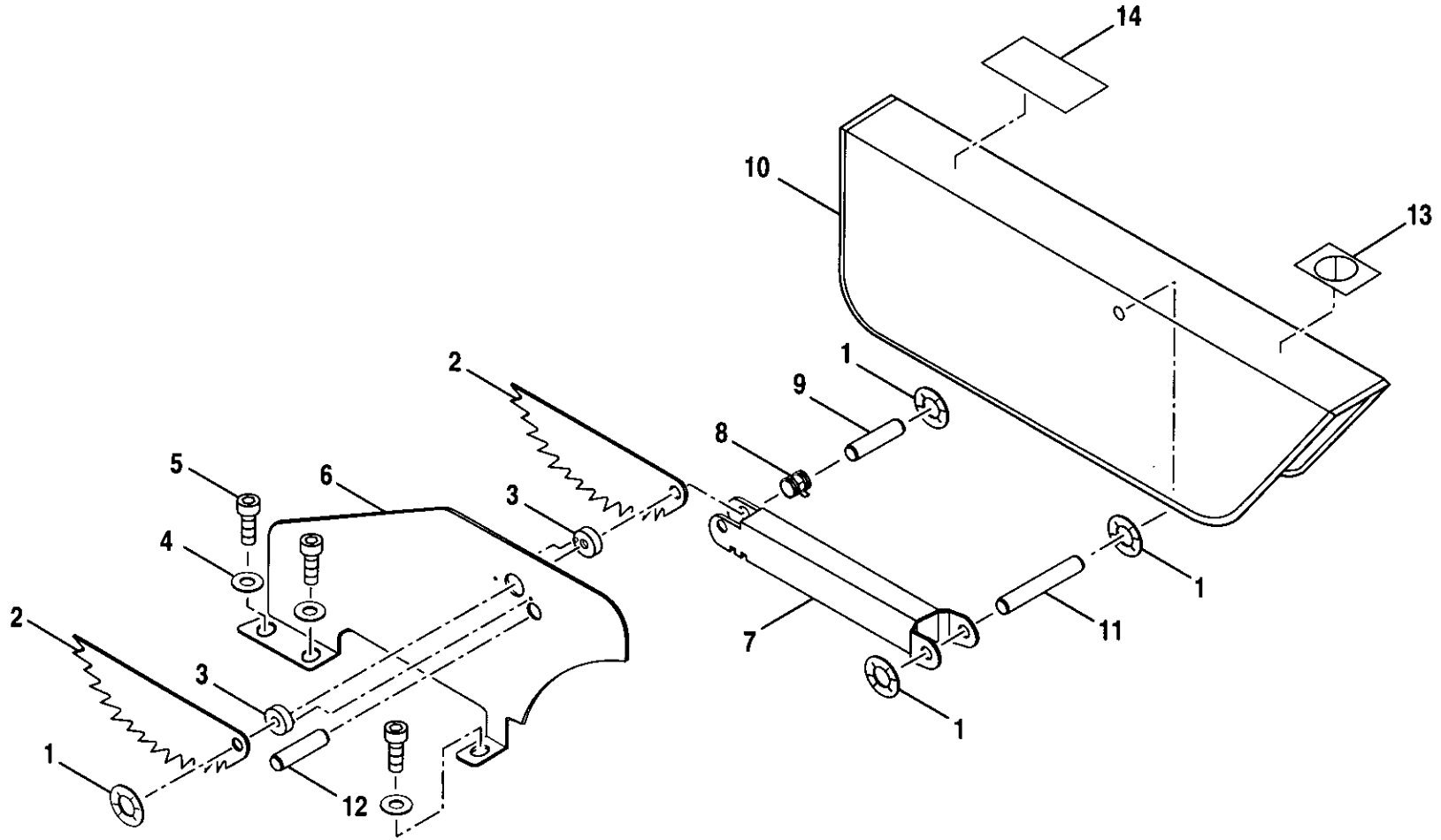

FIGURE D



CRAFTSMAN TABLE SAW – MODEL NO. 315.228590

The model number will be found on a plate attached to the cabinet. Always mention the model number in all correspondence regarding your **TABLE SAW** or when ordering repair parts.

PARTS LIST FOR FIGURE D

Key No.	Part Number	Description	Quan.
1	979935-001	Push Nut	4
2	979940-001	Anti-Kickback Pawl	2
3	979944-001	Spacer	2
4	** STD551025	* Washer (1/4 in.)	3
5	979942-001	* Bolt (1/4-20 x 3/8 in. Socket Head)	3
6	979941-001	Riving Knife	1
7	979937-001	Blade Guard Bracket	1
8	979939-001	Spring	1
9	979938-001	Pin	1
10	979934-001	Blade Guard	1
11	979936-001	Pin	1
12	980955-001	Roll Pin	1
13	980400-001	Warning Label	1
14	980324-001	Blade Guard Label	1
	981279-001	Blade Guard Assembly (Includes Key Nos. 1-14)	1

* Standard Hardware Item — May Be Purchased Locally
 ** Available From Div. 98 — Source 980.00



CRAFTSMAN TABLE SAW – MODEL NO. 315.228590

The model number will be found on a plate attached to the cabinet. Always mention the model number in all correspondence regarding your **TABLE SAW** or when ordering repair parts.

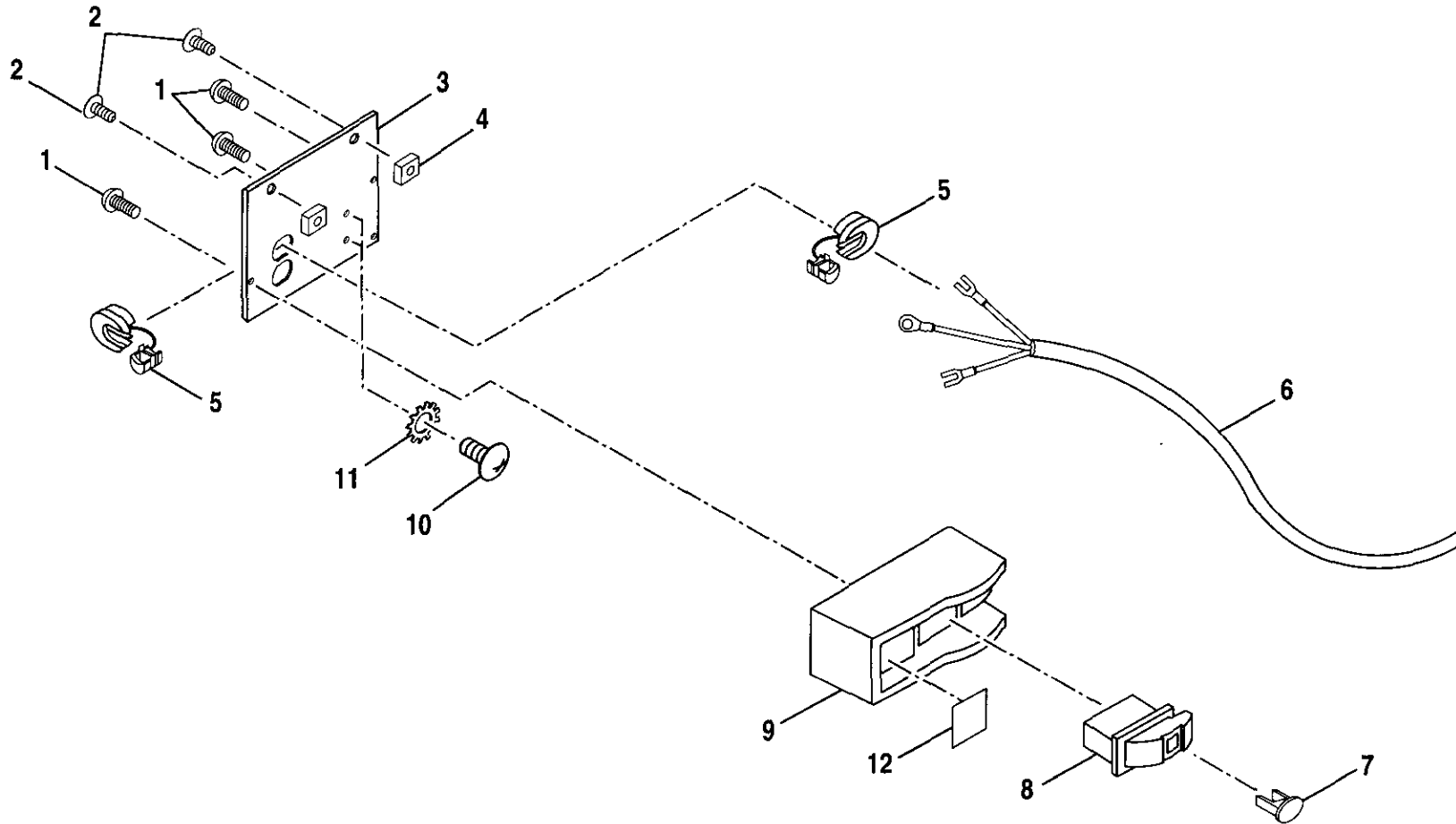

FIGURE E



CRAFTSMAN TABLE SAW – MODEL NO. 315.228590

The model number will be found on a plate attached to the cabinet. Always mention the model number in all correspondence regarding your **TABLE SAW** or when ordering repair parts.

PARTS LIST FOR FIGURE E

Key No.	Part Number	Description	Quan.
1	979945-001	* Screw (#8-32 x 1/2 in.)	3
2	** STD512503	* Screw (1/4-20 x 3/8 in.)	2
3	980652-001	Switch Plate	1
4	980594-001	* Square Nut (1/4-20)	2
5	979986-001	Strain Relief	2
6	979991-001	Power Cord (Power Source)	1
7	976863-001	Switch Key	1
8	980001-001	Switch (Includes Key No. 7)	1
9	979987-001	Switch Housing	1
10	** STD511003	* Screw (#10-24 x 5/16 in.)	2
11	979990-001	* Star Washer (#10)	2
12	980321-001	On/Off Label	1

* Standard Hardware Item — May Be Purchased Locally
 ** Available From Div. 98 — Source 980.00



CRAFTSMAN TABLE SAW – MODEL NO. 315.228590

The model number will be found on a plate attached to the cabinet. Always mention the model number in all correspondence regarding your **TABLE SAW** or when ordering repair parts.

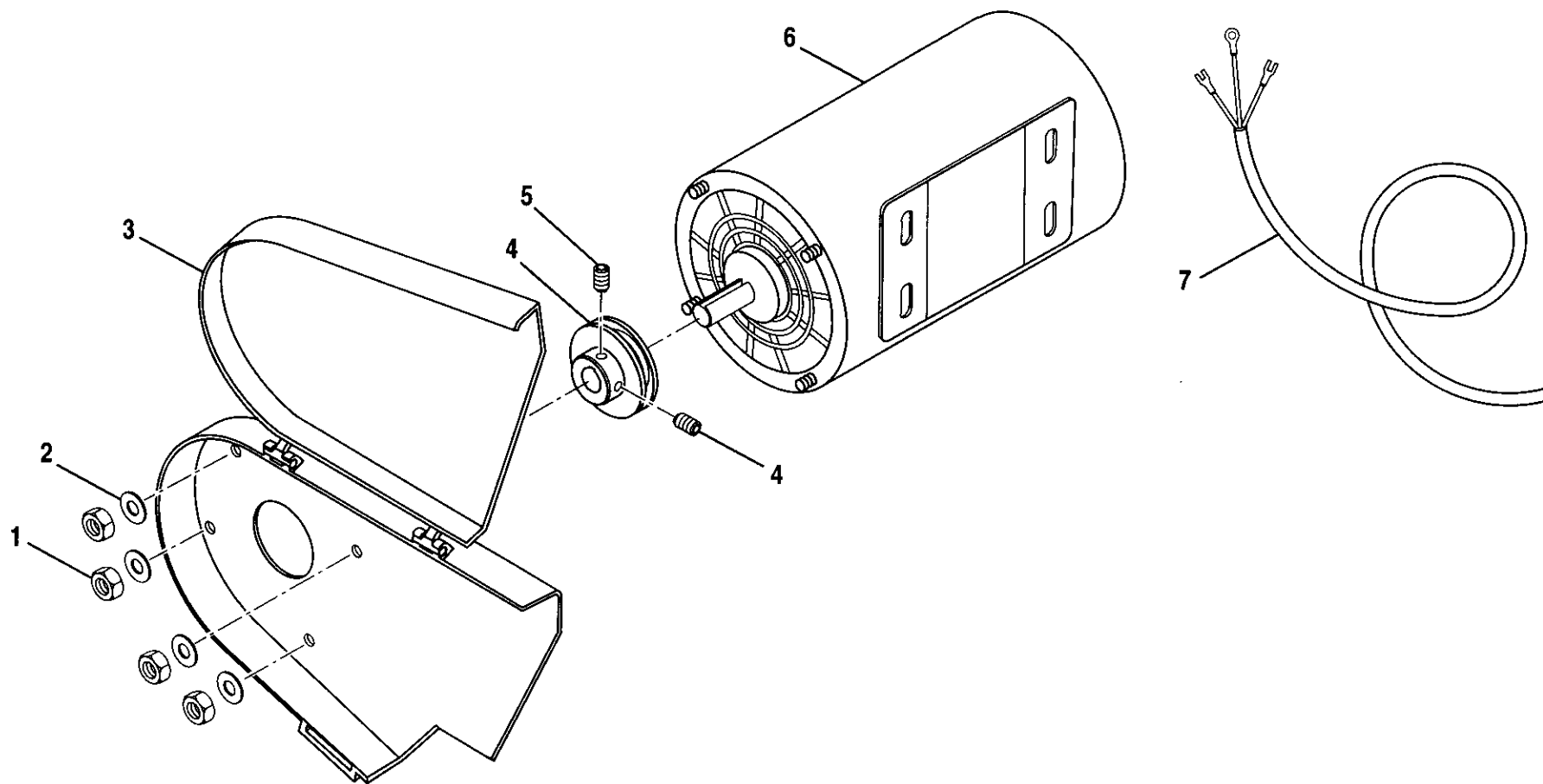

FIGURE F

CRAFTSMAN TABLE SAW – MODEL NO. 315.228590

The model number will be found on a plate attached to the cabinet. Always mention the model number in all correspondence regarding your **TABLE SAW** or when ordering repair parts.

PARTS LIST FOR FIGURE F

Key No.	Part Number	Description	Quan.
1	** STD541010	* Hex Nut (#10)	4
2	** STD551010	* Flat Washer (#10)	4
3	981382-001	Belt Guard	1
4	979900-001	Pulley	1
5	** STD502502	* Setscrew (1/4-20 x 1/4 in.)	2
6	980962-001	Motor	1
7	980960-001	Power Cord (Motor)	1

* Standard Hardware Item — May Be Purchased Locally
 ** Available From Div. 98 — Source 980.00



CRAFTSMAN TABLE SAW – MODEL NO. 315.228590

The model number will be found on a plate attached to the cabinet. Always mention the model number in all correspondence regarding your **TABLE SAW** or when ordering repair parts.

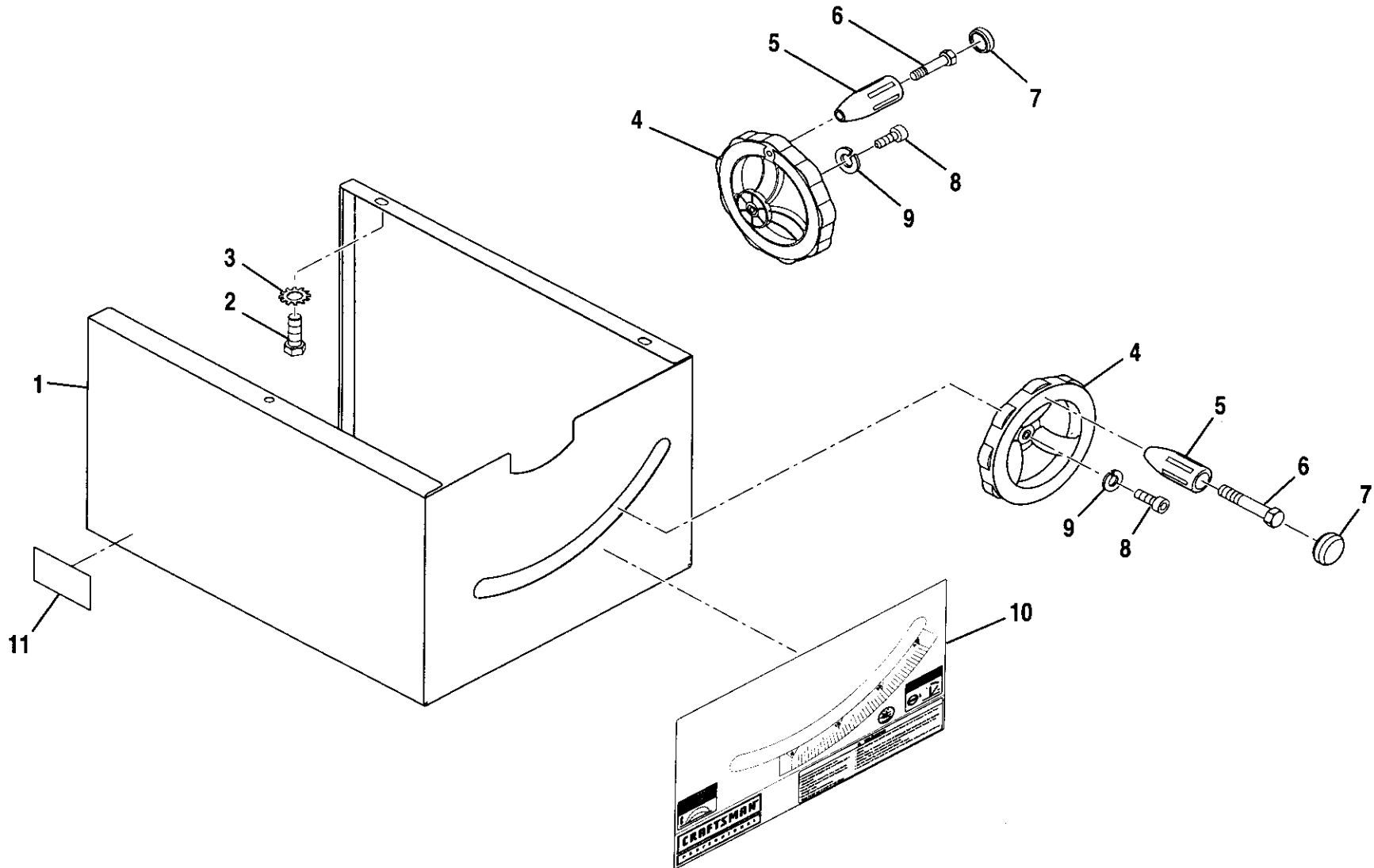

FIGURE G

CRAFTSMAN TABLE SAW – MODEL NO. 315.228590

The model number will be found on a plate attached to the cabinet. Always mention the model number in all correspondence regarding your **TABLE SAW** or when ordering repair parts.

PARTS LIST FOR FIGURE G

Key No.	Part Number	Description	Quan.
1	979992-002	Base	1
2	** STD523105	* Bolt (5/16-18 x 1/2 in. Hex Hd.)	3
3	980588-001	* Star Washer (5/16 in.)	3
4	977227-002	Handwheel Assembly (Includes Key Nos. 5, 6, and 7)	2
5	977229-002	Handle	2
6	977491-001	Screw (M8 x 1-1/4 in.)	2
7	977481-001	End Cap	2
8	980602-001	* Screw (#10-24 x 1/2 in.)	2
9	** STD551110	* Lock Washer (#10)	2
10	982222-001	Front Panel Label	1
11	982128-001	Data Plate	1

* Standard Hardware Item — May Be Purchased Locally
 ** Available From Div. 98 — Source 980.00



CRAFTSMAN TABLE SAW – MODEL NO. 315.228590

The model number will be found on a plate attached to the cabinet. Always mention the model number in all correspondence regarding your **TABLE SAW** or when ordering repair parts.

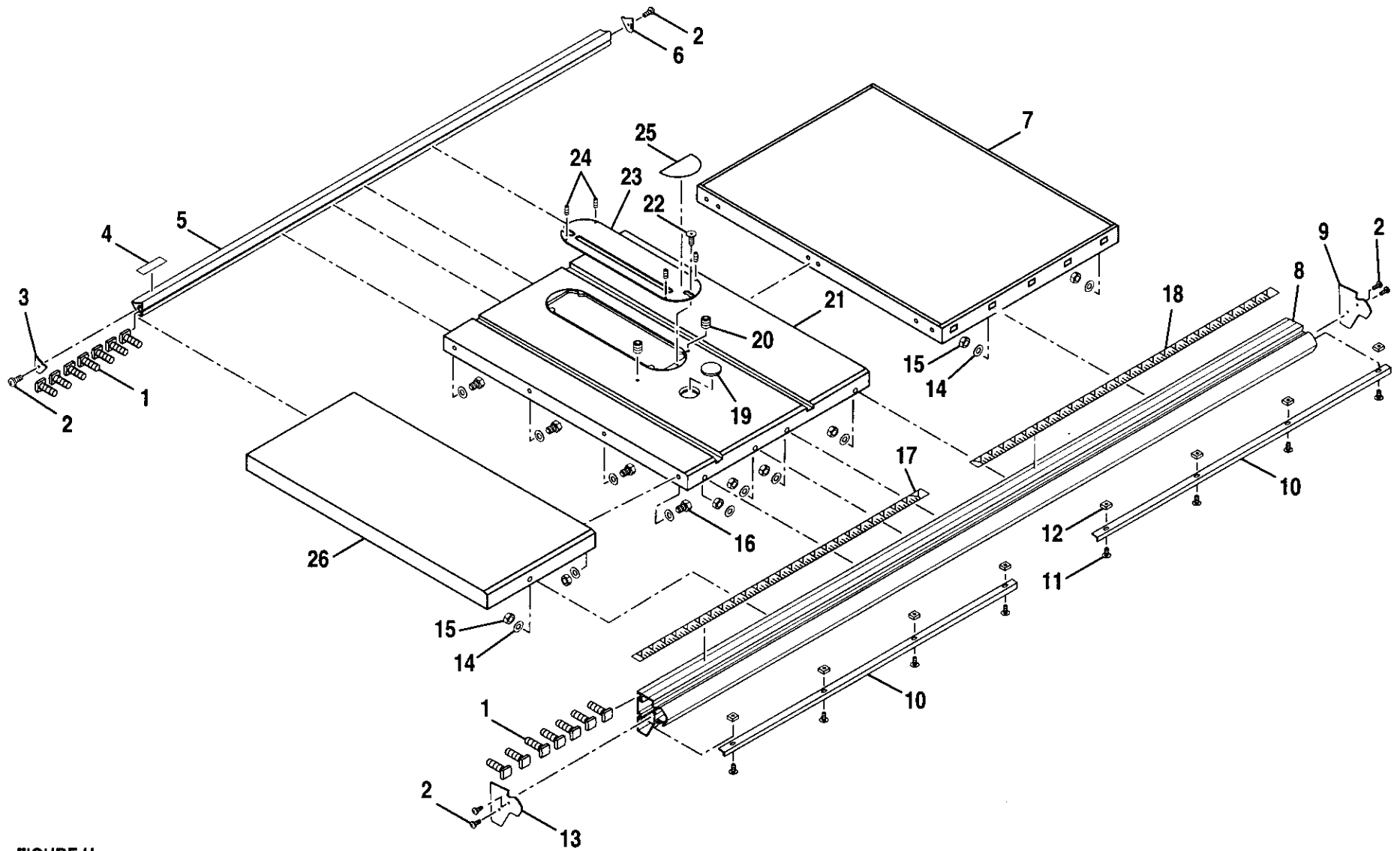

FIGURE H

CRAFTSMAN TABLE SAW – MODEL NO. 315.228590

The model number will be found on a plate attached to the cabinet. Always mention the model number in all correspondence regarding your **TABLE SAW** or when ordering repair parts.

PARTS LIST FOR FIGURE H

Key No.	Part Number	Description	Quan.
1	979879-001	* Bolt (5/16-18 x 1 in. Square Hd.)	14
2	979945-001	* Screw (#8-32 x 1/2 in.)	6
3	979946-001	End Cap (Left Rear)	1
4	980323-001	Label	1
5	980691-001	Rear Rail	1
6	979948-001	End Cap (Right Rear)	1
7	982147-001	MDF Extension Table Assembly	1
8	980695-001	Front Rail (Includes Key Nos. 17 and 18)	1
9	990692-001	End Cap (Right Front)	1
10	980693-001	Gear Rack	2
11	980950-001	* Screw (1/4-20 x 3/8 in.)	8
12	980594-001	* Square Nut (1/4-20)	8
13	980690-001	End Cap (Left Front)	1
14	** STD551131	* Washer (5/16 in.)	22
15	** STD541031	* Hex Nut (5/16-18)	18
16	** STD523110	* Bolt (5/16-18 x 1 in. Hex Hd.)	4
17	982122-001	Scale (Left)	1
18	982271-001	Scale (Right)	1
19	979875-001	Align-A-Cut Insert	1
20	979874-001	* Setscrew (5/16-18 x 5/8 in.)	2
21	980956-002	Saw Table	1
22	979872-001	* Screw (#10-24 x 3/4 in.)	1
23	979871-001	Throat Plate	1
24	979873-001	* Setscrew (#10-24 x 3/16 in.)	4
25	982099-001	Throat Plate Label	1
26	980694-001	Extension Table	1

* Standard Hardware Item — May Be Purchased Locally
 ** Available From Div. 98 — Source 980.00



CRAFTSMAN TABLE SAW – MODEL NO. 315.228590

The model number will be found on a plate attached to the cabinet. Always mention the model number in all correspondence regarding your **TABLE SAW** or when ordering repair parts.

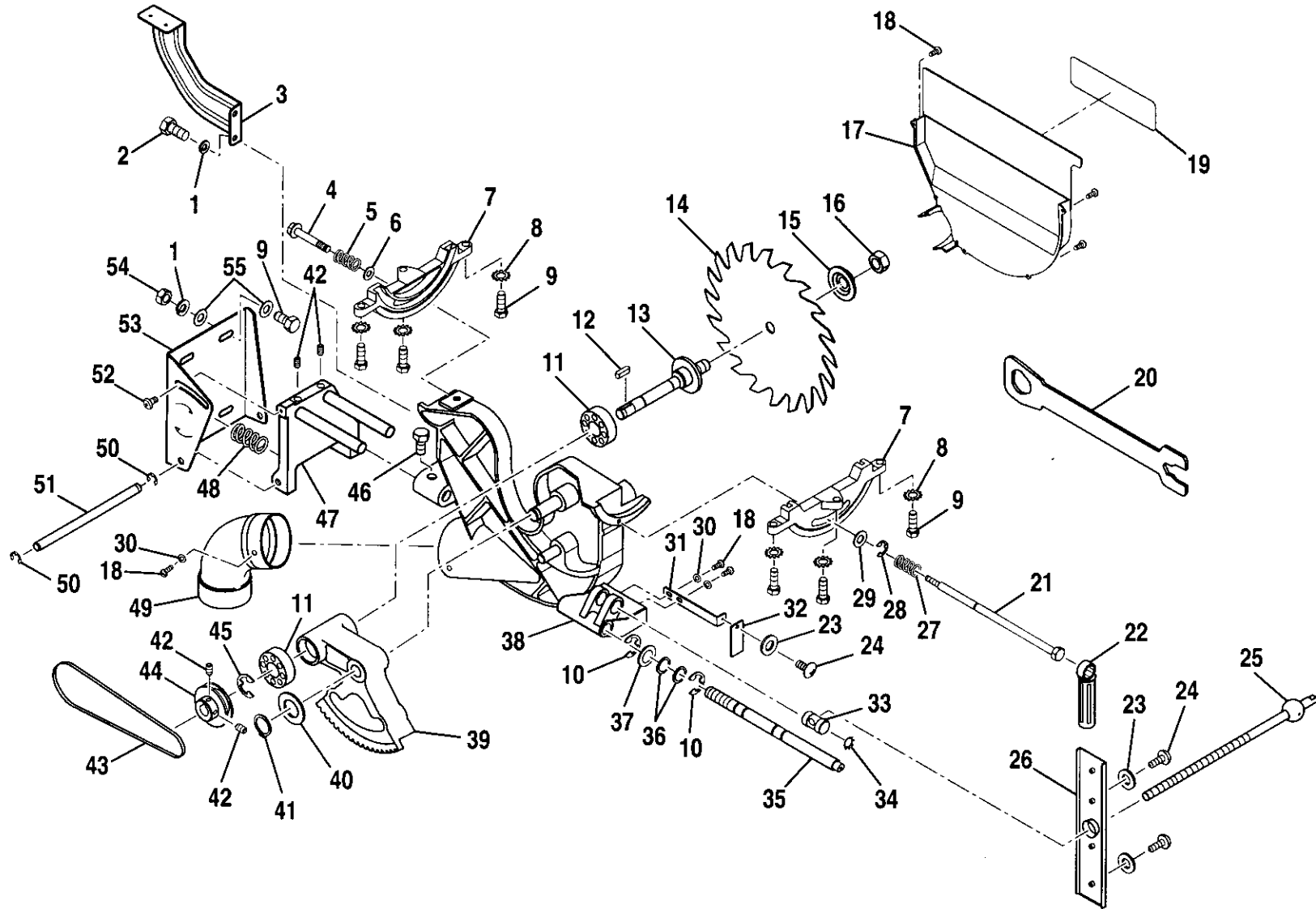

FIGURE I

CRAFTSMAN TABLE SAW – MODEL NO. 315.228590

The model number will be found on a plate attached to the cabinet. Always mention the model number in all correspondence regarding your **TABLE SAW** or when ordering repair parts.

PARTS LIST FOR FIGURE I

Key No.	Part Number	Description	Quan.	Key No.	Part Number	Description	Quan.
1	** STD551131	* Lock Washer (5/16 in.)	6	30	980946-001	* Washer (#10)	3
2	** STD523105	* Bolt (5/16-18 x 1/2 in. Hex Hd.)	2	31	979908-001	Bracket	1
3	979880-001	Riving Knife/Blade Guard Bracket	1	32	979911-001	Bevel Scale Indicator	1
4	979883-001	* Bolt (1/4-20)	1	33	979914-001	Knuckle	1
5	979884-001	Spring	1	34	980589-001	Retaining Ring	1
6	979885-001	Washer	1	35	979924-001	Height Adjustment Rod	1
7	979886-001	Table Bracket	2	36	979923-001	"O" Ring	2
8	980588-001	Star Washer	6	37	979922-001	Washer	1
9	** STD523110	* Bolt (5/16-18 x 1 in. Hex Hd.)	10	38	979897-001	Cradle (Trunnion)	1
10	979896-001	Retaining Ring	2	39	979898-001	Arbor Housing	1
11	979895-001	Ball Bearing (6202Z)	2	40	979902-001	Washer	1
12	979894-001	Key	1	41	979903-001	Retaining Ring	1
13	979893-001	Arbor Shaft	1	42	** STD502502	* Setscrew (1/4-20 x 1/4 in.)	4
14	***	10 in. Blade (Item No. 9 28874)	1	43	** STD304420	V-Belt (4L-420)	1
15	979891-001	Outer Blade Washer	1	44	979900-001	Pulley	1
16	979890-001	Blade Nut	1	45	980593-001	Retaining Ring	1
17	982272-001	Blade Cover Assembly	1	46	** STD523107	* Bolt (5/16-18 x 3/4 in. Hex Hd.)	2
18	** STD511003	* Screw (#10-24 x 3/8 in.)	8	47	979925-001	Motor Support Base	1
19	982278-001	Blade Cover Label	1	48	979926-001	Spring	1
20	979889-001	Blade Wrench	1	49	980760-001	Elbow	1
21	979906-001	Shaft	1	50	979904-001	Retaining Ring	2
22	979907-002	Bevel Lock Handle	1	51	979927-001	Pivot Shaft	1
23	979912-001	* Washer (#8)	5	52	979928-001	Screw	1
24	979910-001	* Screw (#8-32 x 3/8 in.)	5	53	979929-001	Motor Mounting Plate	1
25	979917-001	Threaded Rod	1	54	** STD541031	* Hex Nut (5/16-18)	4
26	979915-001	Bracket	1	55	** STD551031	* Washer (5/16 in.)	8
27	979905-001	Spring	1	56	980757-001	Dust Bag (Not Shown)	1
28	979904-001	Retaining Ring	1		972000-782	Owner's Manual	
29	979885-001	Washer	1				

* Standard Hardware Item — May Be Purchased Locally

** Available From Div. 98 — Source 980.00

*** Complete Assortment Available At Your Nearest Sears Retail Store



Get it fixed, at your home or ours!

For repair of major brand appliances **in your own home...**
no matter who made it, no matter who sold it!

1-800-4-MY-HOMESM Anytime, day or night
(1-800-469-4663)

www.sears.com

To bring in products such as vacuums, lawn equipment and electronics
for repair, call for the location of your nearest **Sears Parts & Repair Center.**

1-800-488-1222 Anytime, day or night

www.sears.com

For the replacement parts, accessories and owner's manuals
that you need to do-it-yourself, call **Sears PartsDirectSM!**

1-800-366-PART 6 a.m. – 11 p.m. CST,
(1-800-366-7278) 7 days a week

www.sears.com/partsdirect

To purchase or inquire about a Sears Service Agreement:

1-800-827-6655

7 a.m. – 5 p.m. CST, Mon. – Sat.

Para pedir servicio de reparación a domicilio,
y para ordenar piezas con entrega a domicilio:

1-888-SU-HOGARSM
(1-888-784-6427)

Au Canada pour service en français:

1-877-LE-FOYERSM
(1-877-533-6937)

