

Operator's Manual



Mid-Engine Rider

**13.5 HP. Electric Start
30" Mower / Mulcher
Variable Speed**

Model 536.270270

CAUTION: Before using this product, read this manual and follow all of its Safety Rules and Operating Instructions.

Manual del usuario

**Tractor cortacésped
con motor situado
detrás del asiento**

**Arranque eléctrico de 13,5 caballos
Cortacésped / trituradora de 76 cm.
Velocidad variable**

Modelo 536.270270

PRECAUCIÓN: Antes de usar este producto, lea este manual y siga todas las reglas de seguridad e instrucciones de operación.

- Safety
- Operation
- Maintenance
- Parts

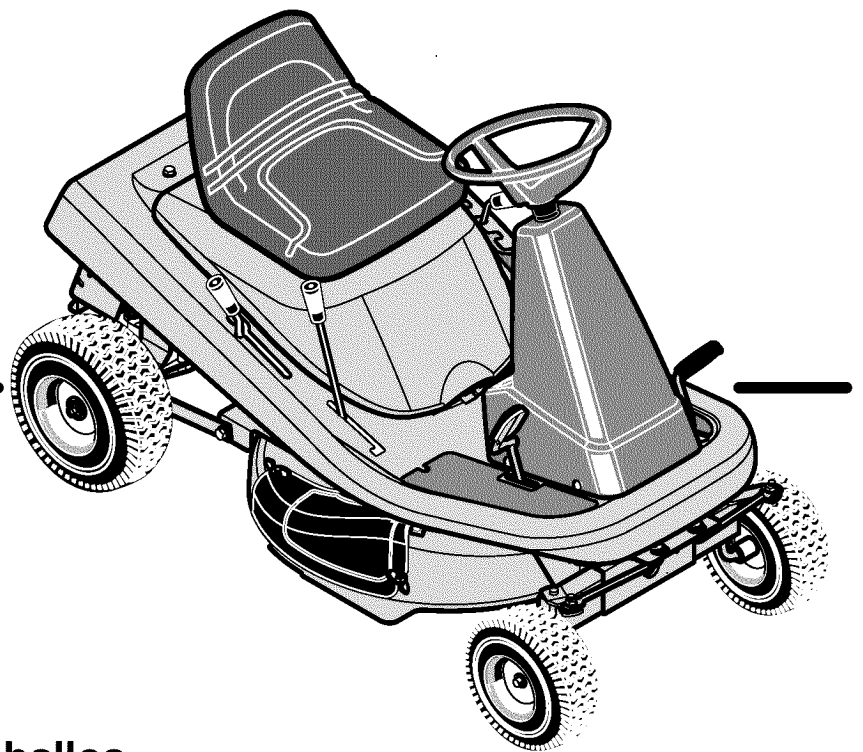

- Seguridad
- Operación
- Mantenimiento
- Piezas

Sears, Roebuck and Co., Hoffman Estates, IL. 60179 U.S.A.

F-020611L

www.sears.com/craftsman

TABLE OF CONTENTS

WARRANTY	2	MAINTENANCE	19
PRODUCT SPECIFICATIONS	3	SERVICE AND ADJUSTMENT	25
SAFETY RULES	4	TROUBLE SHOOTING CHART	36
PREPARATION	7	SLOPE GUIDE	39
OPERATION	10	REPAIR PARTS	40

LIMITED WARRANTY ON CRAFTSMAN RIDING EQUIPMENTMID-ENGINE RIDER

For two (2) years from the date of purchase, if this Craftsman Riding Equipment is maintained, lubricated and tuned up according to the instructions in the owner's manual, Sears will repair or replace free of charge any parts that are found to be defective in material or workmanship according to the guidelines of coverage listed below.

Sears will also provide free labor for these applicable warranted parts for the two full years. During the first 30 days of purchase, there will be no charges to service the product at your home for issues covered by this warranty. (See exclusions below).

For your convenience, IN HOME warranty service will still be available after the first 30 days of purchase, but a trip charge will apply. This charge will be waived if the Craftsman product is dropped off at an authorized Sears location. For the nearest authorized Sears location, please call 1-800-4-MY-HOME®. This warranty applies only while this product is within the United States.

EXCLUSIONS

This Warranty does not cover:

- Expendable items which become worn during normal use, including but not limited to blades, spark plugs, air cleaners, belts, and oil filters.
- Standard Maintenance Servicing, oil changes, or tune-ups
- Tire replacement or repair caused by punctures from outside objects, such as nails, thorns, stumps or glass.
- Repairs necessary because of operator abuse, including but not limited to, damage caused by towing objects beyond the capability of the riding equipment, impacting objects that bend the frame or crankshaft, or over-speeding the engine.
- Repairs necessary because of operator negligence, including but not limited to, electrical and mechanical damage caused by improper storage, failure to use the proper grade and amount of engine oil, failure to keep the deck clear of flammable debris, or failure to maintain the equipment according to the instructions contained in the owner's manual.
- Engine (fuel system) cleaning or repairs caused by fuel determined to be contaminated or oxidized (stale). In general, fuel should be used within 30 days of its purchase date.
- Normal deterioration and wear of the exterior finishes, or product label replacement.
- Riding equipment used for commercial or rental purposes.

LIMITED WARRANTY ON BATTERY

For ninety (90) days from date of purchase, if any battery included with this riding equipment proves defective in material or workmanship and our testing determines the battery will not hold a charge, Sears will replace the battery at no charge. During the first 30 days of purchase, there will be no charges to replace the battery at your home. After the first 30 days, for your convenience, IN-HOME warranty service will still be available but a trip charge will apply. This charge will be waived if the Craftsman product is dropped off at an authorized Sears location. For the nearest authorized Sears location, please call 1-800-4-MY-HOME®. This Warranty applies only while this product is within the United States. This warranty gives you specific legal rights, and you may also have other rights, which vary, from state to state.

Sears, Roebuck and Co., Dept. 817WA, Hoffman Estates, IL 60179



Congratulations on your purchase of a Craftsman Mid-Engine Rider. It has been designed, engineered and manufactured to give you the best possible dependability and performance.

If you experience any problems you cannot easily remedy, please see your nearest Sears Service Center. We have competent, well trained technicians and the proper tools to service or repair this unit.

Please read and keep this manual. The instructions will enable you to assemble and maintain your unit properly. Always observe the "Safety Rules".

PRODUCT SPECIFICATIONS

Engine	13.5 HP.
Charging System	3 amperes at 3600 rpm
Fuel Tank Size	1.1 gallon
Type of Fuel	Unleaded Regular
Oil Capacity	32 ounces (1 quart)
Oil Type	Above 32 degrees SAE 30
.....	Below 32 degrees SAE 5W30
Spark Plug (Gap 0.030") ..	Champion RJ4C
Tire Air Pressure	Front 22 psi (See tire sidewall)
Tire Air Pressure	Rear 14 psi (See tire sidewall)
Drive System	Variable Speed
Ground Speed Range	Forward 5.0 mph
.....	Reverse 2.5 mph
Tilt Seat	Access to engine and battery.
Mower Housing	Full-floating suspension, one blade.
Cutting Height	6 positions from 1 1/2 to 4 inches.
Blade Nut Torque	30 foot-pounds (ft-lbs)

Craftsman Mid-Engine Rider

Record in the space below the serial number and the date of purchase of this unit.

The model number and serial number are found on a decal attached to the unit.

Model Number: **536.270270**_____

Serial Number: _____

Date of Purchase: _____

Keep these numbers for future reference.

REPAIR PROTECTION AGREEMENT

A Repair Protection Agreement is available on this unit. See the nearest Sears Store for information.



WARNING:



Engine Exhaust, some of its constituents, and certain vehicle components contain or emit chemicals known to the State of California to cause cancer and birth defects or other reproductive harm.

Battery posts, terminals and related accessories contain lead and lead compounds, chemicals known to the State of California to cause cancer and birth defects or other reproductive harm. WASH HANDS AFTER HANDLING.

NOTE: This unit is equipped with an internal combustion engine and must not be used on or near any unimproved forest-covered, brush-covered or grass-covered land unless the engine's exhaust system is equipped with a spark arrester meeting applicable local or state laws (if any). If a spark arrester is used, it must be maintained in effective working order by the operator.

In the State of California, the above is required by law (Section 4442 of the California Public Resources Code). Other states may have similar laws. Federal laws apply on federal lands. See a Sears Service Center for a spark arrester for the muffler.

In some areas, local law requires the use of a resistor spark plug to control the ignition signals. See a Sears Service Center for a resistor spark plug for the engine.

NOTE: Actual sustained horsepower will likely be lower due to operating limitations and environmental factors.

SAFETY RULES

Safe Operation Practices for Riding Vehicles As Recommended by American National Standards Institute



WARNING: This cutting machine is capable of amputating hands and feet and throwing objects. Failure to observe the following safety instructions could result in serious injury or death to the operator or bystanders.

GENERAL OPERATION:

1. Read, understand and follow all instructions in the Instruction Book, on the machine, the engine and with any attachments before starting.
2. Only allow responsible adults familiar with the instructions to operate the machine.
3. Clear the area of objects such as rocks, toys, wire, etc. which could be picked up and thrown by the blade.
4. Be sure the area is clear of other people before mowing. Stop the machine if anyone enters the area.
5. Never carry passengers.
6. Disengage power to the mower or any attachments before backing up. Do not mow in reverse unless absolutely necessary. Always look down and behind before and while backing.
7. Be aware of the direction the mower discharges. Do not point discharge from the mower at anyone or at places where people may be. Do not operate the mower without either the entire grass bagger or the mower guard in place.
8. Slow down before turning.
9. Never leave a machine unattended with the engine running. Always disengage the blade(s), set the parking brake, stop the engine and remove the key before dismounting.
10. Disengage power to attachment(s) when transporting or not in use. Disengage the blade(s) when not mowing.
11. Stop the engine before removing the grass bagger or unclogging the chute.
12. Mow only in daylight or good artificial light.
13. Do not operate the machine while under the influence of alcohol or drugs or when very tired.
14. Watch for traffic when operating near or crossing roadways.
15. Use extra caution when loading or unloading the machine when using a trailer or truck for transporting.
16. Disengage all attachment clutches and shift into Neutral before attempting to start the engine.
17. Always wear safety glasses or an eye shield when you operate the unit to protect your eyes from foreign objects that can be thrown from the unit. Always wear eye protection when you make an adjustment or repair to the machine.
18. Use care when pulling loads or using heavy equipment.
 - a. Use only approved drawbar hitch points.
 - b. Limit loads to those you can safely control.
 - c. Do not turn sharply. Use care when backing.
 - d. Use counterweights or wheel weights when suggested in the Instruction Book.
19. Do not operate this machine if you are taking drugs or other medication which can cause drowsiness or affect your ability to operate this machine.
20. Do not use this machine if you are mentally or physically unable to operate this machine safely.

21. Data indicates that operators, age 60 years and above, are involved in a large percentage of riding mower related injuries. These operators should evaluate their ability to operate a riding mower safely enough to protect themselves and others from serious injury.

SLOPE OPERATION:

Slopes and rough terrain are major factors related to loss of control and tip over accidents which can result in severe injury or death. ALL slopes require extra caution. If you cannot back up the slope or if you feel uneasy on the slope, do not mow it. See the "Slope Guide" in the back of this book to check for safe operation.

DO

1. Mow up and down slopes, not across.
2. Remove obstacles such as rocks, limbs, etc...
3. Watch for holes, ruts or bumps. Uneven terrain could overturn the machine. "Tall grass can hide obstacles."
4. Use slow speed. Choose a low enough gear so that you will not have to stop or shift while on the slope.
5. Follow the manufacturer's recommendations for wheel weights or counterweights to improve stability.
6. Use extra care with grass baggers or other attachments, they can change the stability of the machine.
7. Keep all movement on the slopes **slow and gradual**. Do not make sudden changes in speed or direction.
8. Avoid starting or stopping on a slope. If tires lose traction, disengage the blades and proceed slowly **straight down** the slope.

DO NOT

1. **Do not** turn on slopes unless absolutely necessary, then only turn slowly and gradually downhill, if possible.
2. **Do not** mow near drop-offs, ditches or embankments. A wheel over the edge or an edge caving in could cause a sudden overturn and an injury or death.
3. **Do not** mow on wet grass. Reduced traction could cause sliding.
4. **Do not** try to stabilize the machine by putting your foot on the ground.
5. **Do not** use a grass bagger or other rear mounted accessories on steep slopes (greater than 10 degrees).

SAFETY RULES

CHILDREN:

Tragic accidents can occur if the operator is not alert to the presence of children. Children are often attracted to the machine and the mowing activity. NEVER assume that children will remain where you last saw them.

1. Keep children out of the mowing area and in the watchful care of an adult other than the operator.
2. Be alert and turn the engine off if children enter the area.
3. Before and when backing, look **behind and down** for small children.
4. Never carry children or any passengers. They may fall off and be seriously injured or interfere with the safe operation of the machine.
5. Never allow children to operate the machine. Instruct children in the dangers of the machine.
6. Use extra care when approaching blind corners, shrubs, trees or other objects that may obscure vision.

SERVICE:

1. Use extra care when handling gasoline and other fuels. Fuels are flammable and the vapors are explosive.
 - a. Use only an approved container.
 - b. Never remove the gas cap or add fuel with the engine running. Allow the engine to cool for several minutes before refueling. Do not smoke.
 - c. Never refuel the machine indoors.
 - d. Never store the machine with fuel in the tank or fuel container inside where there is an open flame, such as a water heater.

2. Never start or run the engine inside a closed area.
3. Keep all nuts and bolts, especially the blade attachment nuts tight. Frequently check the blade(s) for wear or damage such as cracks and nicks. A blade that is bent or damaged must be immediately replaced with an original equipment blade from an authorized service dealer. For safety, replace the blade every two years. Keep the equipment in good condition.
4. Never tamper with the safety devices. Check their proper operation regularly.
5. To reduce fire hazards keep the machine free of grass, leaves or other debris build-up. Clean up oil or fuel spills. Allow the machine to cool before storing.
6. Stop and inspect the equipment if you strike an object. Repair, if necessary, before restarting.
7. Never make adjustments or repairs with the engine running. The carburetor can be adjusted with the engine running. Do not change the engine governor settings or overspeed the engine.
8. Grass bagger components are subject to wear, damage and deterioration, which could expose moving parts or allow objects to be thrown. For storage, always make sure the grass bag is empty. Frequently check components and replace with manufacturer's recommended parts when necessary.
9. Mower blade(s) are sharp and can cut. Wrap the blade(s) or wear gloves and use extra caution when servicing them or the blade housing area.
10. Check the brake operation frequently. Adjust and service as required.
11. Wait for all movement to stop before servicing any part of the unit.



Look for this symbol to indicate important safety precautions. This symbol indicates: "Attention! Become Alert! Your Safety Is At Risk."

SAFETY RULES

INTERNATIONAL PICTORIALS

IMPORTANT: Some of the following pictorials are located on your unit or on literature supplied with the product. Before you operate the unit, learn and understand the purpose for each pictorial.

Safety Warning Pictorials

- | | | |
|---|--|---|
| 1 Warning | 5 Flush Eyes Immediately With Water. Get Medical Help Fast. | 10 DANGER: No Step. |
| 2 Shield Eyes. Explosive Gases Can Cause Blindness Or Injury. | 6 IMPORTANT: Read Owner's Manual Before Operating This Machine. | 11 DANGER: Keep Feet And Hands Away From Rotating Blade. |
| 3 No Sparks, Flames or Smoking. | 7 WARNING: Thrown Objects. Keep Bystanders Away. Read User Instructions Before Operating This Machine. | 12 DANGER: Keep Hands Away From Rotating Blade. |
| 4 Sulphuric Acid Can Cause Blindness Or Severe Burns | 8 WARNING: Do Not Use This Machine On Slopes Greater Than 15 Degrees. | 13 DANGER: Disconnect Spark Plug Wire Before Servicing Unit. |
| | 9 DANGER: Keep People, Especially Children, Away From Unit. | 14 WARNING: Hot Surface. |
| | | 15 WARNING: Use Caution When Connecting Or Disconnecting Accessories. |
| | | 16 WARNING: Crushed Fingers. |

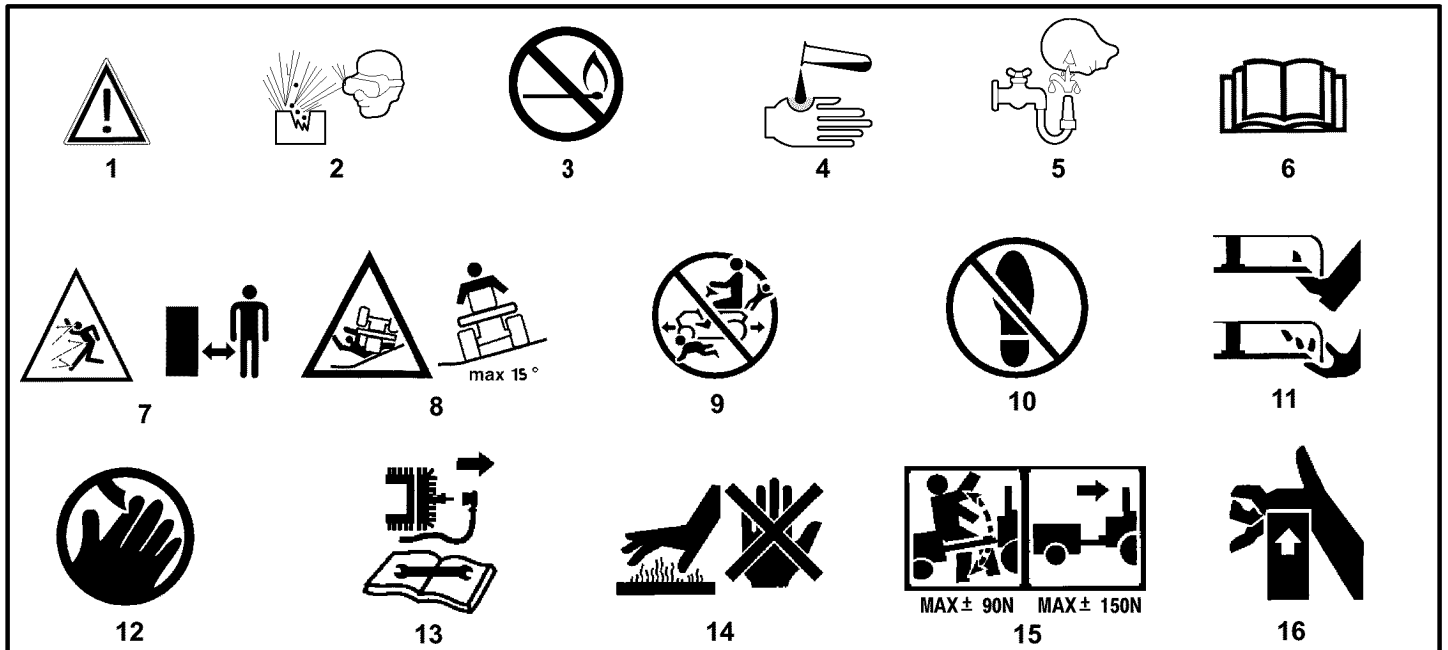

Control And Operating Pictorials

- | | | |
|----------------|-----------------|---------------------------|
| 1 Engine Start | 6 Brake | 11 Choke |
| 2 Lights | 7 Parking Brake | 12 Oil |
| 3 Engine Stop | 8 Clutch | 13 Blade Rotation Control |
| 4 Engine Stop | 9 Slow | 14 Raise |
| 5 Engine Run | 10 Fast | 15 Fuel |

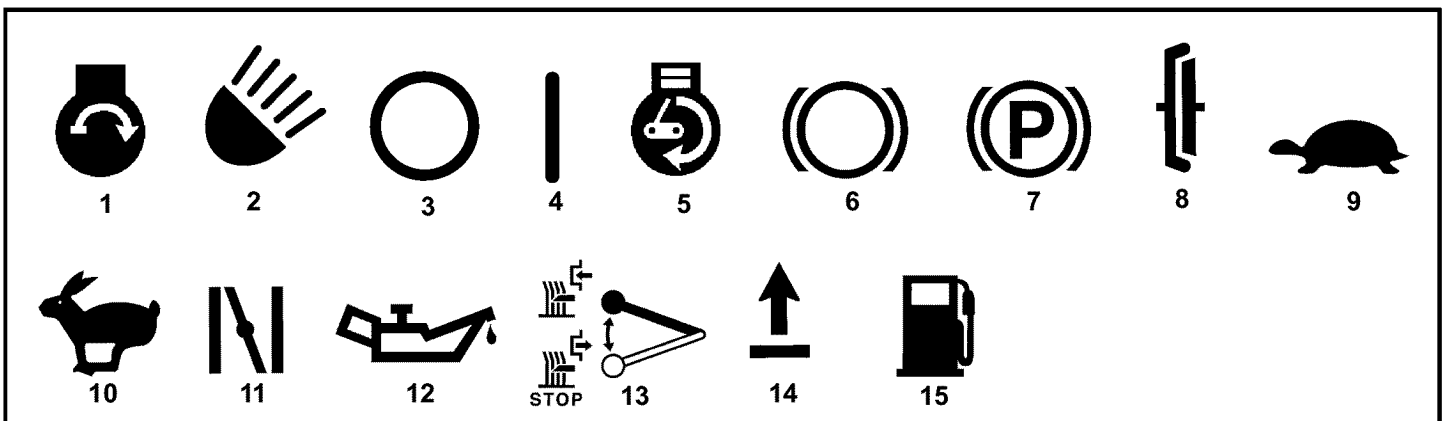

PREPARATION

PREPARATION

Read and follow the preparation instructions for your mower. All fasteners are in the parts bag. Do not discard any parts or material until the unit is assembled.

NOTE: In this instruction book, left and right describe the location of a part from the viewpoint of someone setting in the operator's seat.



WARNING: Before doing any preparation or maintenance to the mower, remove the wire from the spark plug.

The unit is completely assembled except for the items shown below. These items are in the carton along with a parts bag. The parts bag contains the fasteners needed to complete the preparation of the unit. Find and remove these items. Do not discard any parts or material until the unit is assembled.

HOW TO REMOVE FROM THE CARTON

To remove the unit from the carton, follow the instructions below.

1. Locate the two tear tabs at the top of the carton.
2. Pull the tear tape no more than twelve inches at a time.
3. Re-grasp the tear tape next to the carton and pull again.
4. One the tear tape has been completely removed from both ends, remove the top wood and set aside.
5. Repeat the process on the tear tabs at the bottom of the carton.
6. Set the panels aside.
7. Move the shift lever to the neutral (N) position.

NOTE: See the Operation section, page 10, for the location of the controls.

8. If the parking brake is engaged, completely depress the clutch/brake pedal to release the brake.
9. Move the lift lever to the highest position.

CAUTION: Check the bottom of the carton for staples. Remove any staples that are in the path of the tires.

10. Remove the mower from the shipping skid.

LOOSE PARTS – CONTENTS

The fasteners and other loose parts are shown below. The fasteners are shown full size. The quantity is shown in brackets ().

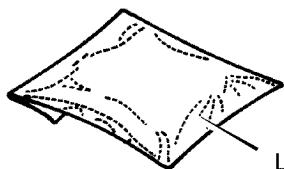

Literature Kit

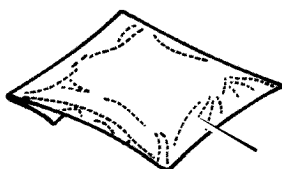

Parts Bag

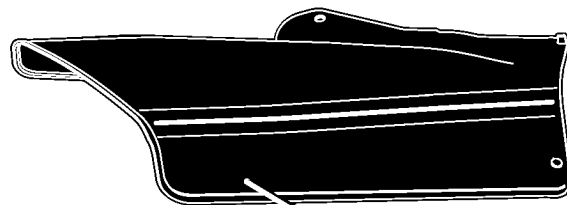

Side Discharge Attachment

PARTS BAG – CONTENTS

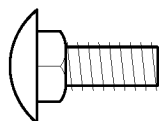

2x82
(2) Carriage Bolt

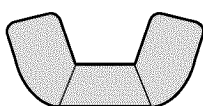

14x79
(2) Wing Nut

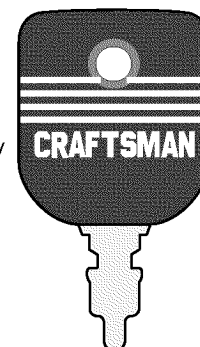

(2) Ignition Key

PREPARATION

MAINTENANCE FREE BATTERY

IMPORTANT: Before you attach the battery cables to the battery, check the battery date. The battery date tells if the battery must be charged.

1. Raise the seat support and secure in the UP position with the seat support rod.
2. Check the top of the battery for the location of the **battery date** (Figure 1).
3. If the **battery** is put into service *before* the **battery date**, the **battery** cables can be attached without charging the **battery**. See "How To Install The Battery Cables".
4. If the **battery** is put into service *after* the **battery date**, the **battery** must be charged. See "How To Charge The Maintenance Free Battery".

HOW TO CHARGE THE MAINTENANCE FREE BATTERY



WARNING: When you charge the battery, do not smoke. Keep the battery away from any sparks. The fumes from the battery acid can cause an explosion.

1. To disconnect the **battery retainer** from the **battery tray**, push in on the lower end of the **battery retainer**.
2. Remove the **battery** from the right side of the unit.

3. Remove the protective caps from the **battery terminals**.
4. Use a 12 volt battery charger to charge the **battery**. Charge at a rate of 6 amperes for one hour. If you do not have a battery charger, have a Sears or other qualified Service Center charge the battery.
5. Install the **battery** and secure with the **battery retainer**. Make sure the **positive (+) terminal** is on the right side.

HOW TO INSTALL THE BATTERY CABLES



WARNING: To prevent sparks, fasten the red cable to the positive (+) terminal before you connect the black cable.

Use the fasteners shown below to install the **battery cables**. The fasteners are shown at full size.

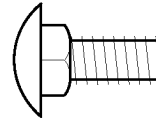

(A)
2x82

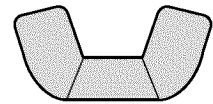

(B)
14x79

1. Remove the protective caps from the **battery terminals**.
2. Fasten the **red cable** to the **positive (+) terminal** with the fasteners as shown (Figure 1).
3. Fasten the **black cable** to the negative (-) terminal with the fasteners as shown.

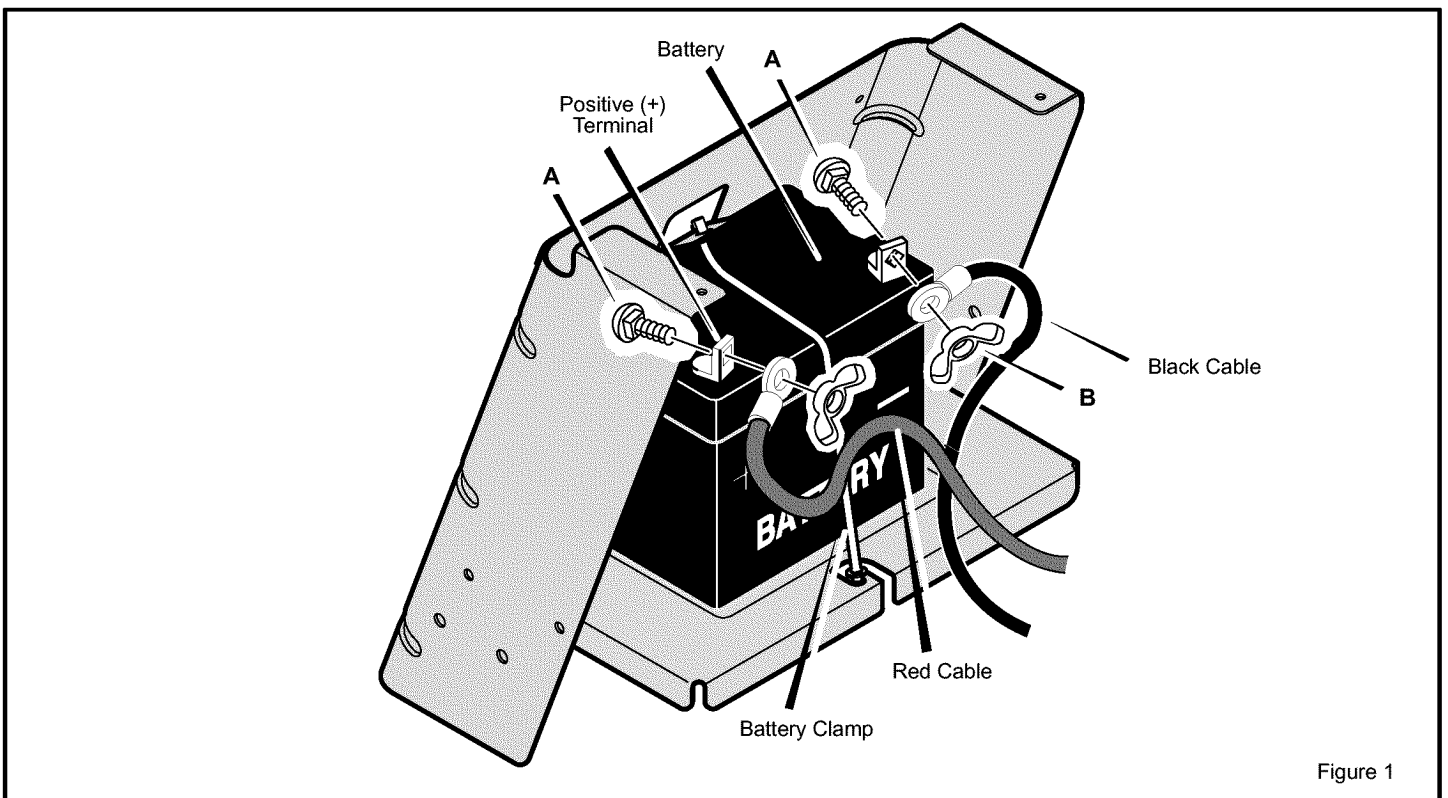

Figure 1

PREPARATION

HOW TO PREPARE THE ENGINE

NOTE: The engine was shipped from the factory filled with oil. Check the level of the oil. Add oil as needed.

Before you use the unit, read the information on safety, operation, maintenance, and storage.

CHECK THE LEVEL OF THE MOWER HOUSING

Make sure the level of cut is still correct. After you mow a short distance, look at the area that was cut. If the mower housing does not cut level, see the instructions on “How To Level The Mower Housing” in the Service And Adjustment section of this instruction book.

CHECK THE TIRES

Check the air pressure in the tires. Tires with too much air pressure will cause the unit to ride rough. Also, the wrong air pressure will keep the mower housing from cutting level. The correct air pressure (PSI) is as follows. Semi-pneumatic front tires do not require air.

Front Tires	22 PSI (1.5 BAR)
Rear Tires	14 PSI (1 BAR)

IMPORTANT! BEFORE YOU START MOWING

- Check the engine oil.
- Fill the fuel tank with gasoline.
- Check the level of the mower housing.
- Check the air pressure of the tires.
- Make sure the battery cables are attached.

OPERATION

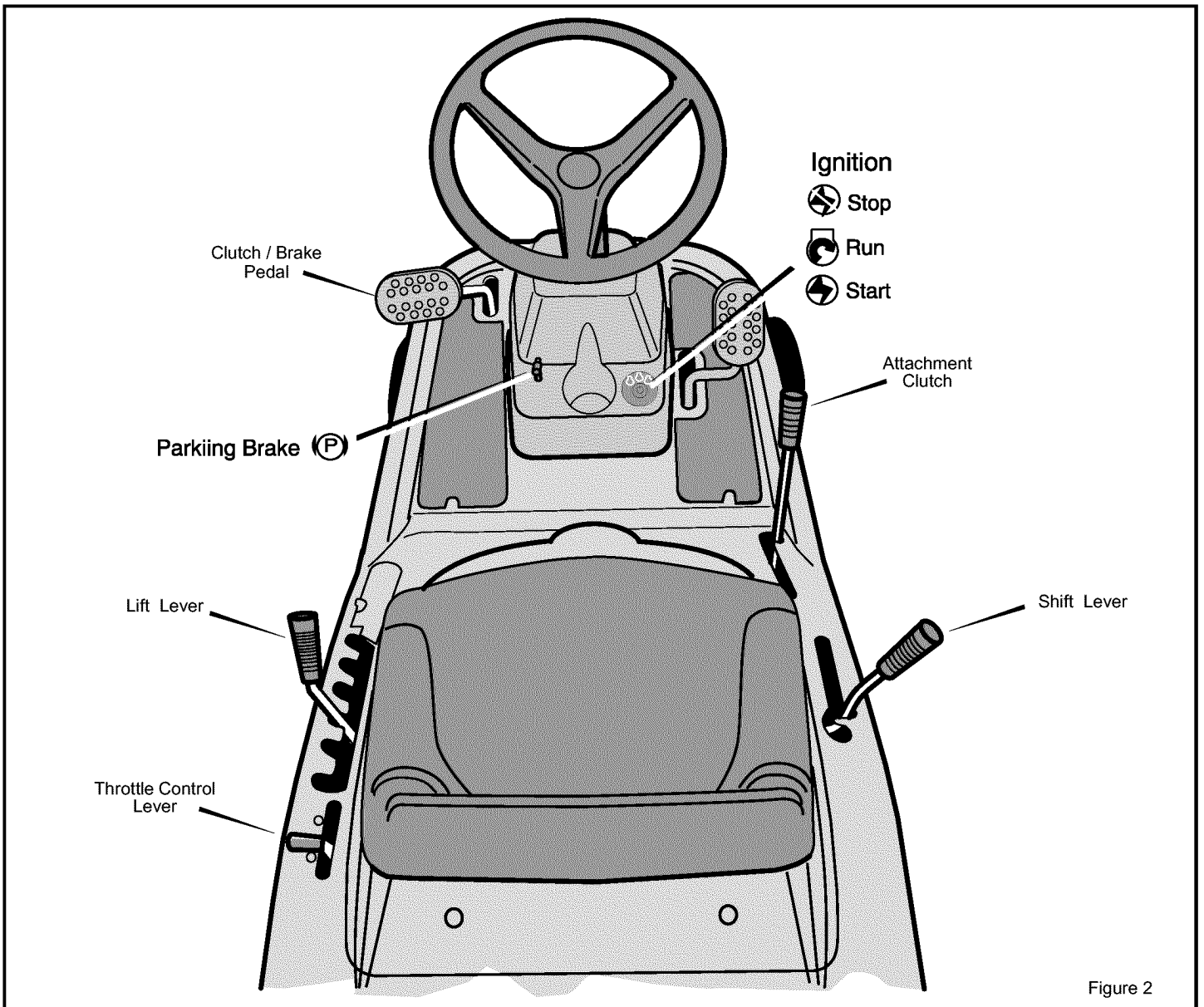

The operation of any lawn mower can result in foreign objects thrown in the eyes, which can result in severe eye damage. Always wear safety glasses or eye shields before starting your lawn mower and while mowing. We recommend standard safety glasses or a wide vision safety mask worn over spectacles.

LOCATION OF CONTROLS

ATTACHMENT CLUTCH: Use the attachment clutch to start and stop the rotation of the blade(s) and to operate a snow thrower attachment.

CLUTCH / BRAKE PEDAL: The pedal has two functions. The first function is a clutch. The second function is a brake.

IGNITION SWITCH: Use the ignition switch to start and stop the engine.

SHIFT LEVER: Use the shift lever to change the speed and the direction of the unit.

LIFT LEVER: Use the lift lever to change the height of cut.

PARKING BRAKE LEVER: Use the parking brake lever to engage the brake when you leave the unit.

THROTTLE CONTROL LEVER: Use the throttle control lever to increase or decrease the speed of the engine.

SPEED CONTROL PEDAL: Use the speed control pedal to change the speed of the unit.

OPERATION

HOW TO STOP THE UNIT

The electrical system has an operator presence system that includes a sensor switch mounted in the seat. These components tell the electrical system if the operator is sitting on the seat. This system will stop the engine when the operator leaves the seat. For your protection, always make sure this system operates correctly.

1. Completely push the **clutch/brake pedal** forward to stop the unit. Keep your foot on the pedal.
2. Move the attachment clutch to the **DISENGAGE** position.

3. Move the shift lever to the **NEUTRAL** position.
4. Set the parking brake.



WARNING: Make sure the parking brake will hold the unit.

5. Move the throttle control to the **SLOW** position.
6. To stop the engine, turn the ignition key to the **OFF** position. Remove the key.

HOW TO SET THE PARKING BRAKE

1. Completely push the **clutch/brake pedal** forward.
2. Lift the **parking brake lever** (Figure 3).
3. Remove your foot from the clutch/brake pedal and then release the **parking brake lever**. Make sure the parking brake will hold the unit.
4. To release the **parking brake**, completely push the **clutch/brake pedal** forward. The **parking brake** will automatically release.



WARNING: Before you leave the operator's position, move the shift lever to the neutral (N) position. Set the parking brake. Move the attachment clutch to the DISENGAGE position. Stop the engine and remove the ignition key.

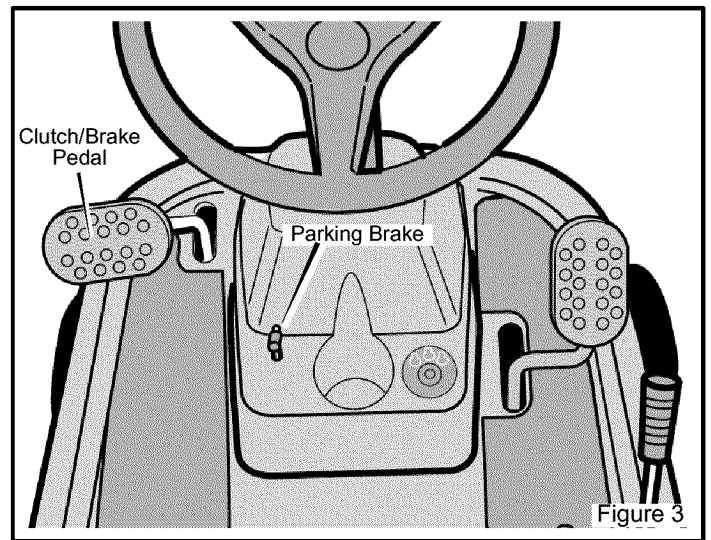

HOW TO USE THE THROTTLE / CHOKE CONTROL

Use the **throttle/choke control** to choke the engine for cold starts and increase or decrease the speed of the engine (see Figure 4).

1. Move the **throttle/choke control** completely forward to the **CHOKE** position to start a cold engine.
2. The **FAST** position is marked with a detent. For normal operation and when using a grass bagger, move the **throttle control** to the **FAST** position. For maximum charging of the battery and for a cooler running engine, operate the engine in the **FAST** position.
3. The engine governor is set at the factory for maximum performance. Do not adjust the governor to increase the speed of the engine.

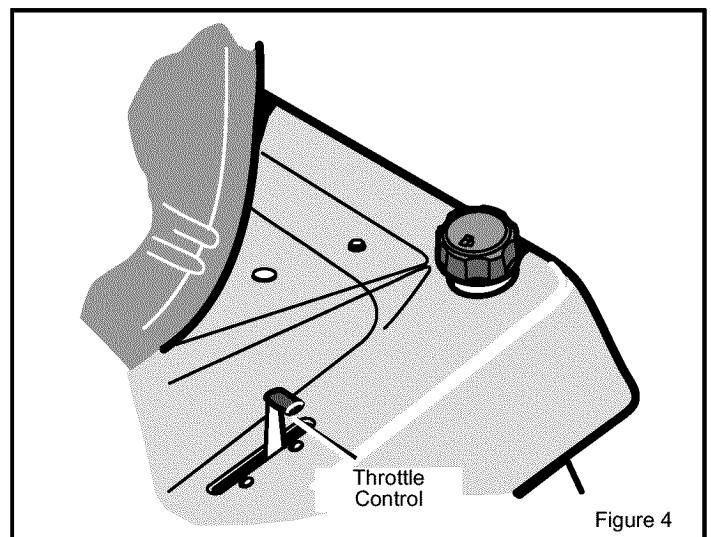

OPERATION

HOW TO USE THE ATTACHMENT CLUTCH

Use the **attachment clutch** to engage the blade (Figure 5).

1. Before you start the engine, make sure the **attachment clutch** is in the **DISENGAGE position**.
2. To rotate the blade, move the **attachment clutch** forward to lock the blade in the **ENGAGE position**.
3. To stop the blade, move the **attachment clutch** to the **DISENGAGE position**. Before you leave the operator's position, make sure the blade has stopped rotating.
4. Before you ride the unit across a sidewalk or a road, move the **attachment clutch** to the **DISENGAGE position**.



WARNING: Always keep your hands and feet away from the blade, deflector opening, and the mower housing when the engine runs.

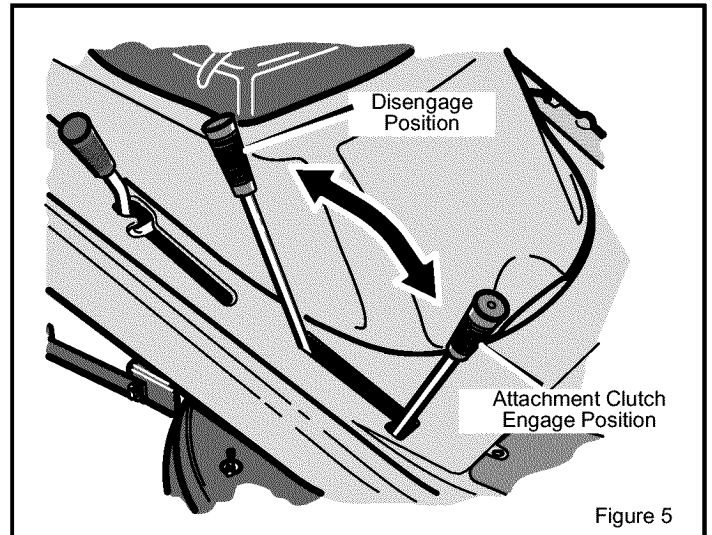

Figure 5

HOW TO CHANGE THE CUTTING HEIGHT

To change the cutting height, raise or lower the **lift lever** as follows.

1. Move the **lift lever** forward to lower the mower housing and back to raise the mower housing (Figure 6).
2. When you ride on a sidewalk or road, move the **lift lever** to the highest position and move the attachment clutch to the DISENGAGE position.

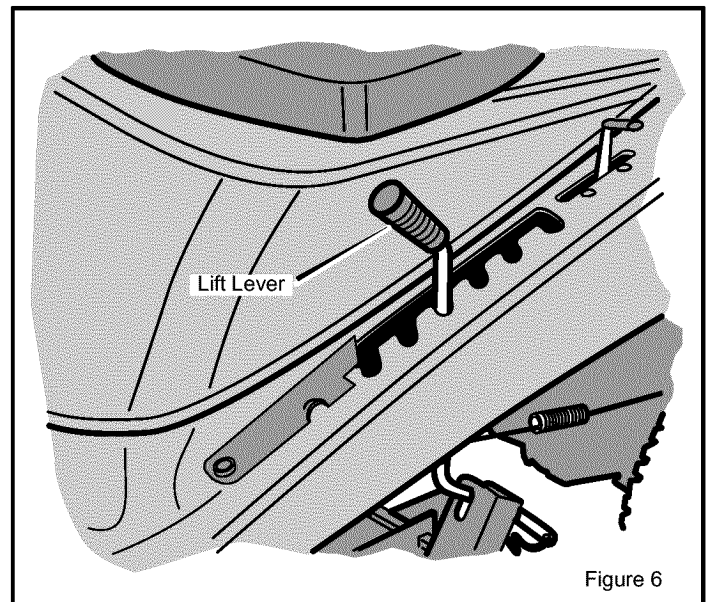

Figure 6

OPERATION

HOW TO USE THE SPEED CONTROL PEDAL

The drive system uses a variator pulley connected to a two speed transaxle. The Variator Drive is very easy to operate. This type of drive system has a two speed shift lever, a clutch/brake pedal on the left side and a speed control pedal on the right side (see Figure 7).

The direction of travel is controlled by the shift lever. Use the shift lever to select either reverse or one of the two forward gears. When operating, the speed is controlled by a single **speed control pedal** operated with your right foot.

HOW TO DRIVE FORWARD

1. Completely push the clutch/brake pedal forward to stop the unit (see Figure 7). Keep your foot on the pedal.
2. Move the shift lever to one of the TWO FORWARD positions (see Figure 8). Select Low position (TRIM) when going up or down steep hills and when operating attachments that require a very slow forward speed. Select High position (MOW) when mowing or when transporting the unit.
3. Slowly release your right foot from the clutch/brake pedal (see Figure 7). Do not keep your foot on the clutch/brake pedal.
4. Move the throttle control to the FAST position (see Figure 9).
5. Slowly push the **speed control pedal** forward to the desired speed (see Figure 7).
6. To increase forward speed, slowly move the **speed control pedal** forward. To reduce forward speed, slowly release the **speed control pedal** until the unit slows to the desired speed.

HOW TO CHANGE DIRECTIONS

CAUTION: Before you move the shift lever, completely push the clutch/brake pedal forward to the stop the unit. If the unit is not stopped, the gearbox can be damaged.

1. Completely push the clutch/brake pedal forward to stop the unit (see Figure 7). Keep your foot on the pedal.
2. Move the throttle control lever to the SLOW position (see Figure 9).
3. To go forward, move the shift lever to one of the TWO FORWARD positions (see Figure 8). To go backward, move the shift lever to the REVERSE position.
4. Slowly release your left foot from the clutch/brake pedal (see Figure 7). Do not keep your foot on the clutch/brake pedal.
5. Move the throttle control to the FAST position (see Figure 9).

HOW TO DRIVE IN REVERSE

1. Look to the rear.
2. Completely push the clutch/brake pedal forward to stop the unit (see Figure 7). Keep your foot on the pedal.
3. Move the shift lever to the REVERSE position (see Figure 8).
4. Slowly release the clutch/brake pedal (see Figure 7).
5. Slowly push the **speed control pedal** forward to the desired speed.
6. To increase reverse speed, slowly move the **speed control pedal** forward. To reduce reverse speed, slowly release the **speed control pedal** until the unit slows to the desired speed.

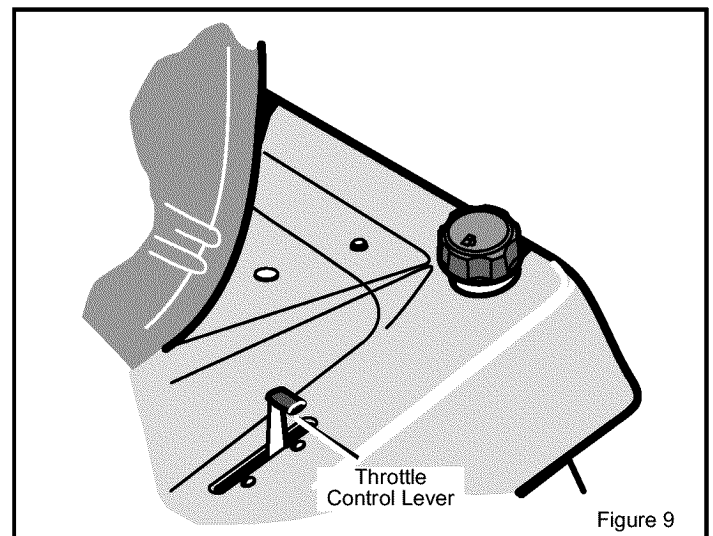
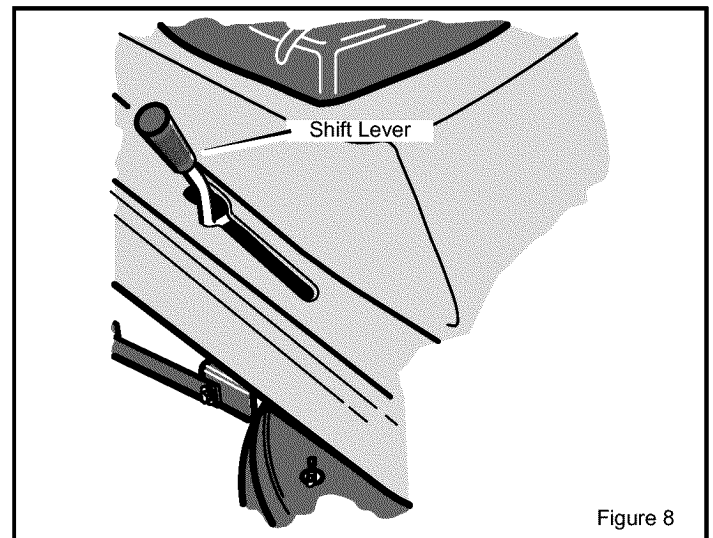
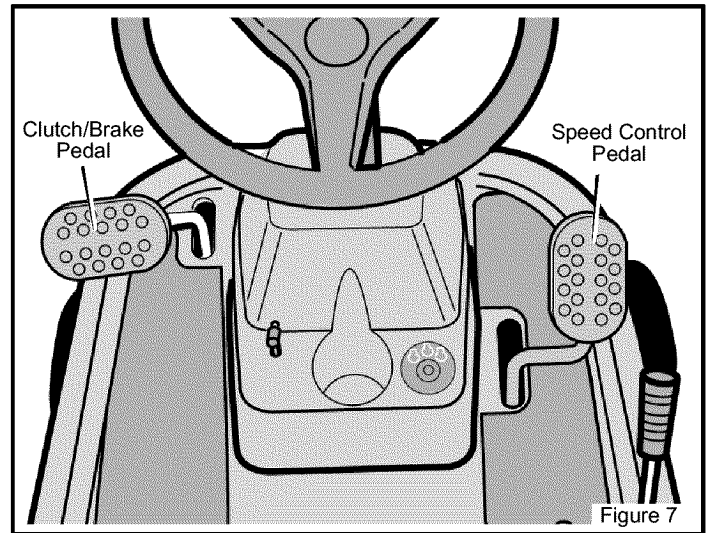

OPERATION

SPEED CONTROL PEDAL POSITIONS

The forward speed is controlled by the position of the **shift lever** and the **speed control pedal**. The following chart provides **functions** along with the positions of the **shift lever** and the **speed control pedal**. Always operate the engine with the **throttle control** in the **FAST** position.

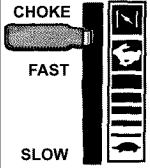
FUNCTION	SHIFT LEVER POSITION	PEDAL POSITION	THROTTLE
Trimming Steep Hills	Low (TRIM)	1/3	 <p>FAST CHOKE</p> <p>FAST</p> <p>SLOW</p> <p>THROTTLE</p>
Bagging Grass	High (MOW)	1/3 to 1/2	
Normal Mowing	High (MOW)	1/2 to 2/3	
Easy Mowing	High (MOW)	1/2 to 3/4	
Transport	High (MOW)	FULL	
Pull Behind Attachments	High (MOW)	1/3 to 1/2	

HOW TO TRANSPORT THE UNIT

To transport the unit, follow the steps below.

1. Move the attachment clutch to the DISENGAGE position.
2. Raise the lift lever to the highest position.
3. Move the throttle control to a position between SLOW and FAST.
4. To go faster, move the shift lever to a faster speed.

OPERATION

HOW TO INSTALL THE SIDE DISCHARGE ATTACHMENT



WARNING: To prevent the engine from starting, disconnect the wire from the spark plug. Make sure the attachment clutch is in the **DISENGAGE** position.

The **mulcher cover** lets you mulch the grass for a clean, fine cut. To discharge the grass out the side, install the **side discharge attachment** as follows.

1. Remove the two **wingnuts** (see Figure 10).
2. Lift the **mulcher cover**. Mount the **side discharge attachment** onto the same bolts that secured the **mulcher cover**.
3. Secure the **side discharge attachment** with the **wingnuts**.
4. To mulch, remove the **side discharge attachment** and mount the **mulcher cover** to the mower housing with the **wingnuts**.

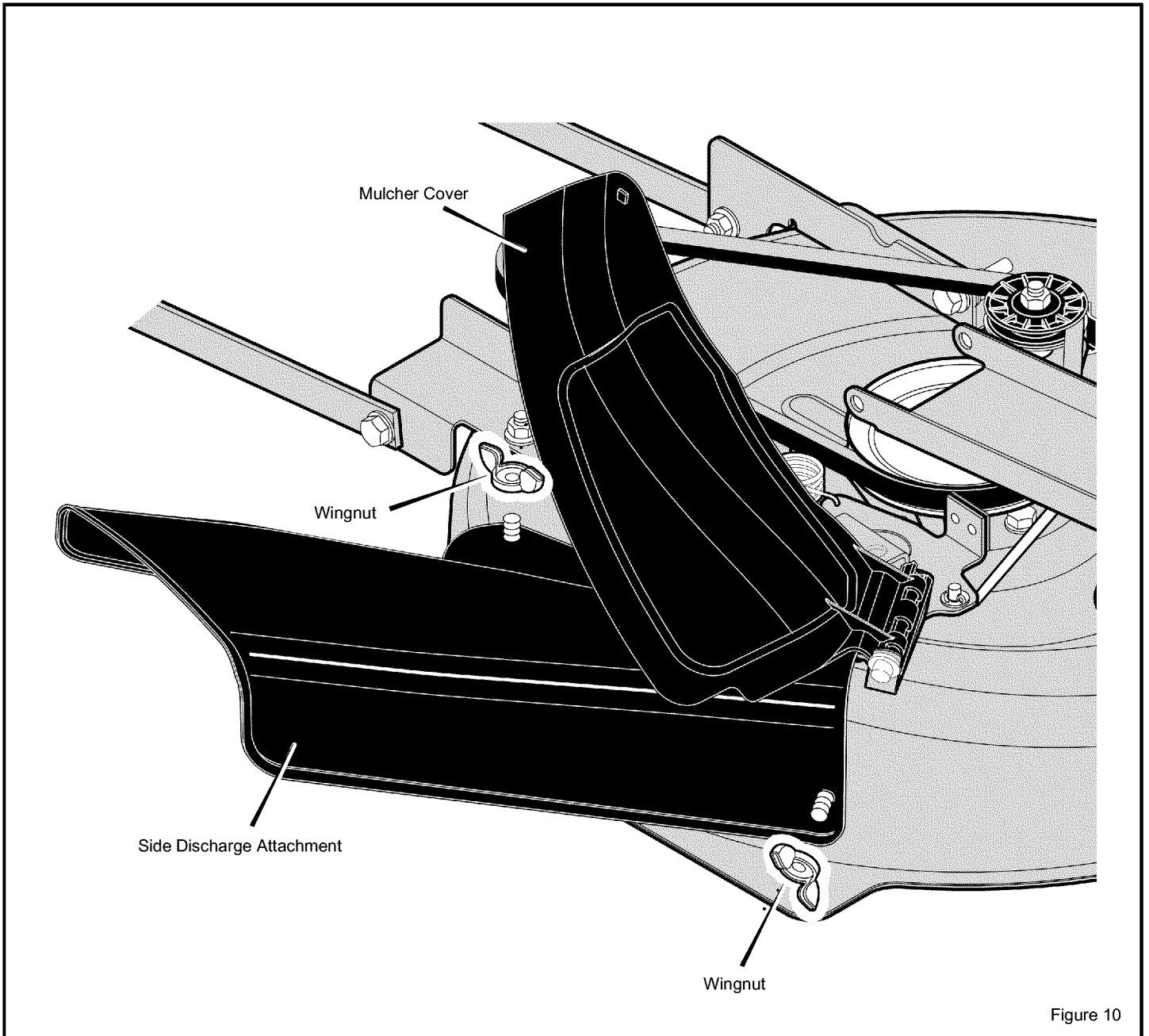

Figure 10

OPERATION

BEFORE STARTING THE ENGINE

CHECK THE OIL

NOTE: The engine was shipped from the factory filled with SAE 30 weight oil. Check the level of the oil. Add oil as needed.

1. Make sure the unit is level.
NOTE: Do not check the level of the oil while the engine runs.
2. Clean the area around the dipstick. Remove the dipstick. Wipe the oil from the dipstick.
3. Insert the dipstick into the oil fill tube. Turn the dipstick clockwise until it is tight. Remove the dipstick. Check the oil level on the dipstick. The oil level must reach the FULL mark on the dipstick.
4. If necessary, add oil until the oil reaches the FULL mark on the dipstick. The quantity of oil needed from ADD to FULL is shown on the dipstick. Do not add too much oil.

ADD GASOLINE



WARNING: Always use a safety gasoline container. Do not smoke when adding gasoline to the fuel tank. Do not add gasoline when you are inside an enclosure. Before you add gasoline, stop the engine and let the engine cool for several minutes.

Fill the fuel tank with regular unleaded gasoline. Do not use premium unleaded gasoline. Make sure the gasoline is fresh and clean. Leaded gasoline will increase deposits and shorten the life of the valves.

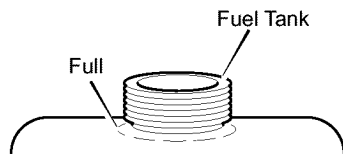

CAUTION: Alcohol blended fuels (called gasohol or using ethanol or methanol) can attract moisture which leads to separation and formation of acids during storage. Acidic gas can damage the fuel system of an engine while in storage.

To prevent engine problems with the fuel system, empty the fuel system before storage of 30 days or longer as follows.

1. Drain the fuel tank.
2. Start the engine. Let the engine run until the fuel lines and the carburetor are empty.
3. After storage, make sure you use fresh fuel. See the storage instructions for additional information.
4. Never use engine cleaner or carburetor cleaner in the fuel tank or permanent damage can occur.

CARBURETOR

The factory settings for the carburetor are for most conditions. If the engine is operated under the following conditions, you can adjust the carburetor mixture. See "How To Adjust The Carburetor" in the Service And Adjustment section.

1. The engine has a loss of power or does not run smooth.
2. A change from summer to winter operation.
3. A 40 degree change in the operation temperature. The carburetor was adjusted at 80 degrees at the factory.
4. The engine is operated above 4,000 feet.

HOW TO START THE ENGINE



WARNING: The electrical system has an operator presence system that includes a sensor switch mounted in the seat. These components tell the electrical system if the operator is sitting on the seat. This system will stop the engine when the operator leaves the seat. For your protection, always make sure this system operates correctly.

NOTE: The engine will not start unless you depress the clutch/brake pedal or engage the parking brake and move the attachment clutch to the DISENGAGE position.

1. Sit in the middle of the seat. Push the clutch/brake pedal completely forward. Keep your foot on the pedal.
2. Move the shift lever to the neutral (N) position.

3. Make sure the attachment clutch is in the DISENGAGE position.
4. Move the throttle control completely forward to the CHOKE or FAST position. Some models have a separate choke knob. Pull the choke knob to the full CHOKE position.
5. Turn the ignition key to the START position. Release the key when the engine starts.

NOTE: If the engine does not start after four or five tries, move the throttle control to the FAST position. Again try to start the engine. If the engine will not start, see the TROUBLESHOOTING CHART.

6. Slowly move the throttle control to the SLOW position. If model has a separate choke knob, push in the choke knob.
7. Let a cold engine run for several minutes. Begin work when the engine is warm. To start a hot engine, move the throttle control to a position between FAST and SLOW.

HOW TO START WITH A WEAK BATTERY

If the battery is too weak to start the engine, the battery needs to be charged. If "Jumper Cables" are used to start the engine in an emergency, follow the procedure below.

NOTE: The unit is equipped with a 12 volt negative to ground system. Also, the other vehicle must have a 12 volt negative to ground system.



WARNING: Do not smoke. The fumes from the battery acid can cause an explosion. Keep the battery away from any flames or sparks. To prevent sparks, fasten the red "Jumper cable" to the positive (+) terminal before connecting the black "Jumper cable".

NOTE: If the seat is raised when starting the engine, move the attachment clutch to the DISENGAGED position and engage the parking brake.

1. Connect each end of the RED "Jumper Cable" to the positive (+) terminals of each battery. Make sure you do not touch the chassis with the cables.
2. Connect one end of the BLACK "Jumper Cable" to the negative (-) terminal of the charged battery.
3. Connect the other end of the BLACK "Jumper Cable" to the mower's engine block.
4. Start the engine that has the weak battery last. Allow the engine to run.
5. To disconnect the "Jumper Cables", reverse the above steps.

OPERATION

HOW TO OPERATE WITH THE MOWER HOUSING



WARNING: The mulch cover is a safety device. Do not remove the mulch cover. The side discharge attachment forces the discharged material toward the ground. Always keep the side discharge attachment in the down position. If the side discharge attachment is damaged, replace the with an original equipment part from a Sears Service Center.

IMPORTANT: When you operate with the mower housing, always operate with the throttle control in the FAST position.

1. Start the engine.
2. Move the lift lever to a height of cut position. In high or thick grass, cut the grass in the highest position first and then lower the mower housing to a lower position.

CAUTION: Do not operate with the mower housing in the LEVEL ADJUSTMENT position. If you operate in the LEVEL ADJUSTMENT position, the mower housing and blades can be damaged.

3. Move the throttle control to the SLOW position.

4. Move the attachment clutch to the ENGAGE position.
5. Push the clutch/brake pedal completely forward.
6. Move the shift lever to one of the speed settings.

NOTE: When you mow in heavy grass or mow with a bagger, put the shift lever in the slowest speed.

7. Slowly release the clutch/brake pedal.
8. Move the throttle control to the FAST position. If you need to go faster or slower, stop the unit and move the shift lever to another speed setting.
9. Make sure the level of cut is still correct. After you mow a short distance, look at the area that was cut. If the mower housing does not cut level, see the instructions on "How To Level The Mower Housing" in the Service And Adjustment section.



WARNING: For better control of the unit, always select a safe speed.

HOW TO OPERATE THE UNIT ON HILLS



WARNING: Do not ride up or down slopes that are too steep to back straight up. Never ride the unit across a slope. See the "Slope Guide" in the back of this book for information on how to check slopes.

1. Before you ride up or down a hill, move the shift lever to the slowest speed.
2. Do not stop or change speed settings on a hill. If you must stop, quickly push the clutch/brake pedal forward and set the parking brake.

3. To start again, make sure the shift lever is in the slowest speed. Move the throttle control to the SLOW position. Slowly release the pedal.
4. If you must stop or start on a hill, always have enough space for the unit to roll when you release the brake and engage the clutch.
5. Be very careful when you change directions on a hill. When on a slope or in a turn on a hill, move the throttle control to the SLOW position to help prevent an accident.

ATTACHMENTS

This unit can use many different attachments. It can pull attachments like a lawn sweeper, a lawn aerator, a hopper spreader, or a small trailer. This unit cannot use attachments that engage the ground like a plow, a disk harrow, or a cultivator.

For all pull-behind attachments or trailers, the maximum gross weight is 200 pounds. Gross weight is the weight of the attachment or trailer and any load that might be on or in it.



WARNING: To avoid possible serious injury, do not mow a slope that is greater than 15 degrees. If the riding mower is used with a pull-behind or rear-mounted attachment, do not operate the unit on a slope that is greater than 10 degrees.

OPERATION

OPERATING TIPS

1. Check the attachment clutch for correct adjustment. For the blade(s) to disengage correctly, the adjustment must be correct.
2. Before you use the unit, check the oil in the engine and add oil if necessary.
3. If the engine will not start, first make sure the wire is attached to the spark plug.
4. Make sure all the belts are inside all the belt guides. See the instructions on how to remove and install the motion drive and mower drive belts.
5. Before you make an inspection, adjustment (except for the carburetor) or repair, make sure the wire from the spark plug is disconnected.
6. Make sure the seat switch wire is connected. If the wire is not connected, the engine will not start.
7. For longer life of the battery, charge the battery every three months.
8. Use the shift lever to change the ground speed, not the throttle control.
9. Belt noise can occur when the blade or clutch is engaged. This noise is normal and does not affect the operation of the unit.
10. To move forward, always release the clutch/brake pedal slowly.

MOWING AND BAGGING TIPS

1. For a lawn to look better, check the cutting level of the mower housing. See "How To Level The Mower Housing" in the Service And Adjustment section.
2. For the mower housing to cut level, make sure the tires have the correct amount of air pressure (PSI).
3. Every time you use the unit, check the blade. If the blade is bent or damaged, immediately replace the blade. Also, make sure the nut for the blade is tight.
4. Keep the blade(s) sharpened. A worn blade(s) will cause the ends of the grass to turn brown.
5. Do not cut or bag grass that is wet. Wet grass will not discharge correctly. Let the grass dry before cutting.
6. Use the left side of the mower housing to trim near an object.
7. Discharge the cut grass onto the mowed area. The result is a more even discharge of cut grass.
8. When you mow large areas, start by turning to the right so that the cut grass will discharge away from shrubs, fences, driveways, etc. After one or two rounds, mow in the opposite direction making left turns until finished (Figure 11).
9. If the grass is very high, cut two times to decrease the load on the engine. First cut with the mower housing in the highest position and then lower the mower housing for the second cut.
10. For better engine performance and an even discharge of the cut grass, always operate the engine with the throttle in FAST position.
11. When you use a bagger, operate the engine with the throttle in FAST position and the shift lever in first or second gear.
12. For better cutting performance and a quality cut, mow with the shift lever in one of the slower speeds.
13. After each use, clean the bottom and top of the mower housing for better performance. Also, a clean mower housing will help prevent a fire.

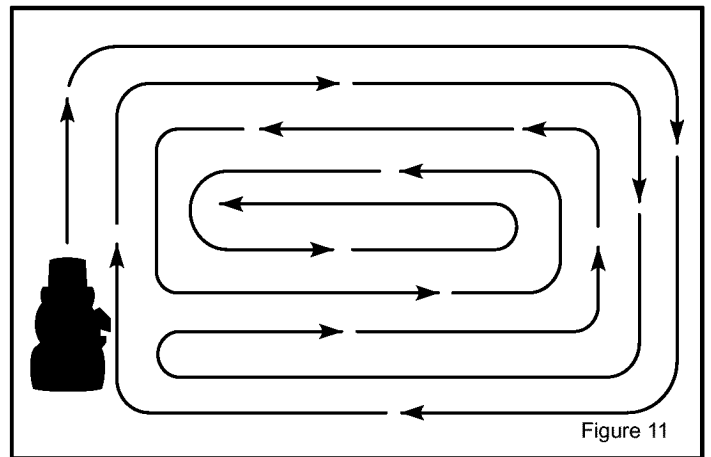

MULCHING TIPS

When you use a mulcher attachment, the grass is cut into very small pieces. These small pieces will quickly break down. Because the nutrients are returned to the soil, the lawn will need less fertilizer. To correctly mulch the grass, follow the steps below.

1. Set the throttle in the FAST position. Operate the mower at a slower ground speed. If ground speed is too fast, the grass will not have an even cut.
2. Keep a sharp edge on the blade. A blade that is not sharp will cause the ends of the grass to become brown.
3. Make sure the grass is dry. Wet grass is difficult to cut.
4. Set the height of the mower housing so that only the top third of the grass is cut. If the grass is too high, set the height of the mower housing to the maximum height. Then, lower the mower housing for the second cut. Also, instead of using the full width of the mower housing, mulch at half the width.
5. Clean the bottom of the mower housing. Grass and other debris can keep the mower from working correctly.
6. If the grass grows fast, mulch more often.
7. If an area needs improvement, mulch a second time.

MAINTENANCE

MAINTENANCE TABLE							
PROCEDURE		EACH USE	FIRST 2 HOURS	EVERY 25 HOURS	EVERY 50 HOURS	EVERY 100 HOURS	BEFORE STORAGE
M O W E R	Tires, Check			√			
	Blade, Inspect and Sharpen			√			
	Drive Brake, Check			√			
	Battery, Check and Charge			√			√
	Battery, Clean				√		√
	Lubrication				√		√
E N G I N E	Oil, Check	√					
	Oil, Change		√				
	Cooling System, Clean	√			√		√
	Muffler, Check				√		√
	Air Filter, Clean				√		
	Spark Plug, Check				√		√
	Spark Plug, Replace						√

GENERAL RECOMMENDATIONS

1. The owner's responsibility is to maintain this product. This will extend the life of the product and is also necessary to maintain warranty coverage.
2. Check the spark plug, drive brake, lubricate the unit, and clean the air filter once a year.
3. Check the fasteners. Make sure all fasteners are tight.
4. Follow the Maintenance and the Service And Adjustment section to keep the unit in good operating condition.



WARNING: Before you make an inspection, adjustment, or repair to the unit, disconnect the wire to the spark plug. Remove the wire from the spark plug to prevent the engine from starting by accident.

CHECK THE TIRES

Check the air pressure in the tires. Tires with too much air pressure will cause the unit to ride rough. Also, the wrong air pressure will keep the mower housing from cutting level. The correct air pressure (PSI) is as follows. Semi-pneumatic front tires do not require air.

Front Tires	22 PSI (1.5 BAR)
Rear Tires	14 PSI (1 BAR)

MAINTENANCE

INSPECT BLADE



WARNING: Before you inspect or remove the blade, disconnect the wire to the spark plug. If the blade hits an object, stop the engine. Check the unit for damage. The blade has sharp edges. When you hold the blade, use gloves or cloth material to protect your hands.

If you keep the blade sharp and inspect the blade for damage, the blade will cut better and be more safe to operate. Frequently check the blade for excessive wear, cracks, or other damage. Frequently check the nut that holds the blade. Keep the nut tight. If the blade hits an object, stop the engine. Disconnect the wire to the spark plug. See if the blade is bent or damaged. Check the blade adapter for damage. Before you operate the unit, replace damaged parts with original equipment parts. See a Sears Service Center in your area. Every three years, have a qualified service person inspect the blade or replace the old blade with an original equipment part.

HOW TO REMOVE AND INSTALL THE BLADE

To Remove

1. Drain the fuel tank.
2. Lift the side of the mower that has the muffler or spark plug.
3. As you loosen the nut, use a piece of wood to keep the blade from rotating.
4. Remove the **nut, washers, and blade** (Figure 12).

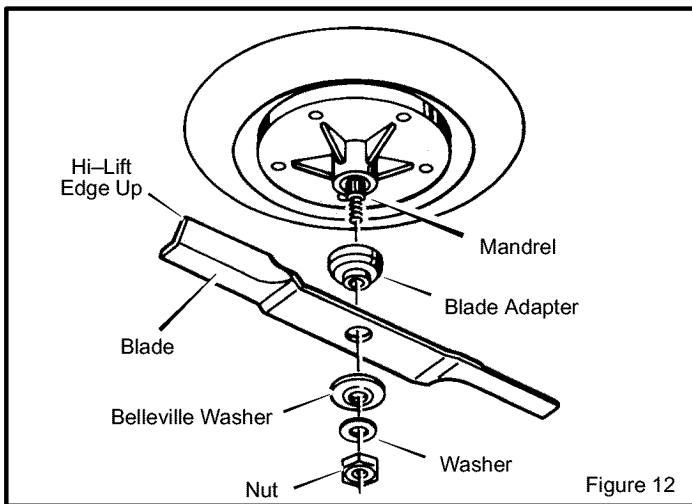

5. Check the **blade** and the **blade adapter** according to the instructions for "Inspect Blade". Replace a badly worn or damaged **blade** with an original equipment blade. See a Sears Service Center in your area.
6. Clean the bottom of the mower housing. Remove all the grass and debris.

To Install

1. Mount the **blade** and **blade adapter** on the **mandrel** (Figure 12).
2. Mount the **blade** so that the **hi-lift edges** are up. If the **blade** is upside down, the **blade** will not cut correctly and can cause an accident.
3. Fasten the **blade** with the original washers and **nut**. Make sure the outside rim of the **Belleville washer** is against the **blade** (Figure 13).



WARNING: Always keep the nut tight that holds the blade. A loose nut or blade can cause an accident.

4. Tighten the **nut** that holds the **blade** to a torque of 35 foot pounds.

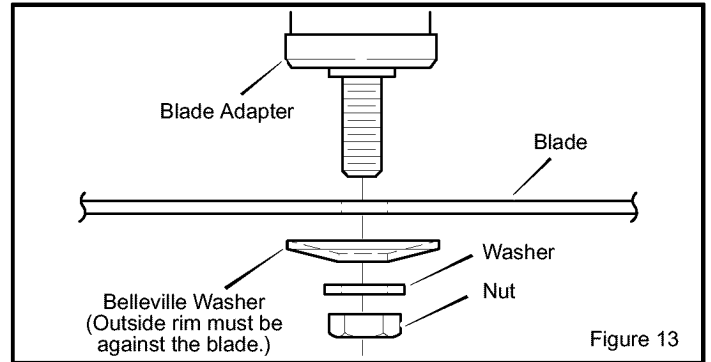

HOW TO SHARPEN THE BLADE



WARNING: Vibration can be caused if the blade is not correctly balanced or if the blade is damaged. A blade that is damaged with cracks can break and cause an accident.

Keep a sharp edge on the **blade**. A **blade** that is not sharp will cause the tips of the grass to become brown.

1. Sharpen the **blade** two times a year or every 25 hours.
2. Remove the **blade** according to the instructions in "How To Remove And Install The Blade".
3. Clean the **blade** with a brush, soap and water. Check the **blade**. Look for cracks, nicks, or other damage. Replace a badly worn or damaged blade with an original equipment blade. See a Sears Service Center in your area.
4. Sharpen the **blade** with a **file** (Figure 14). Make sure you keep the original bevel angle.
5. Make sure the **blade** is balanced. Use a **screwdriver** and hold the **blade** parallel to the **ground** (Figure 14). A **blade** that is balanced will stay parallel to the **ground**. If the **blade** is not balanced, the heavy end will rotate toward the **ground**. Sharpen the heavy end until the **blade** is balanced.
6. A new blade will cut better than a badly worn blade. Every three years, have a qualified service person inspect the blade or replace the old blade with an original equipment blade.
7. Assemble the **blade** according to the instructions "How To Remove And Install The Blade".

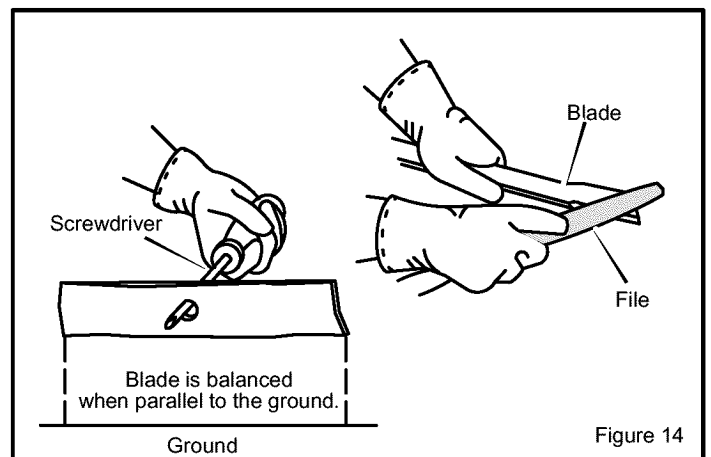

MAINTENANCE

HOW TO CHECK AND ADJUST THE DRIVE BRAKE

Completely push the clutch/brake pedal forward. Set the parking brake. Move the shift lever to the neutral (N) position. Push the unit. If the rear wheels rotate, adjust or replace the brake pads. Adjust the **drive brake** as follows.

1. The location of the **drive brake** is on the left side of the **gearbox** (Figure 15).
2. Make sure the parking brake is set and the shift lever is in neutral (N). Turn the **hex nut** in a clockwise direction until the rear wheels do not turn when the unit is pushed forward.
3. Release the parking brake and push the unit. If the unit does not roll, turn the **hex nut** in a counterclockwise direction until the unit rolls.
4. Set the parking brake. Push the unit. If the rear wheels do not turn, the **drive brake** is correctly adjusted. Release the parking brake.

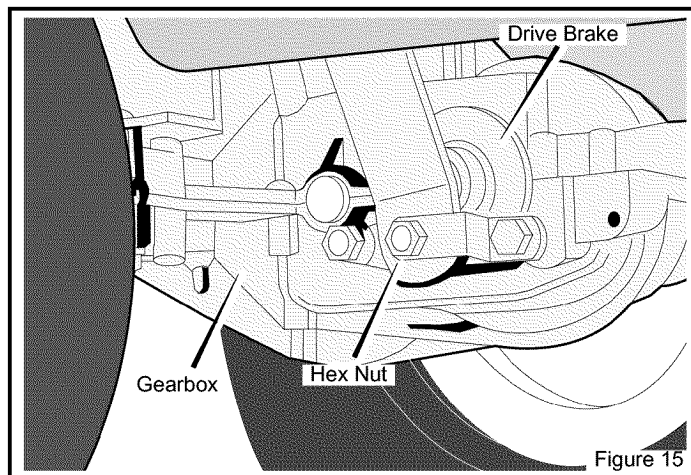

WARNING: If you cannot correctly adjust the drive brake, replace the brake pads. Correct replacement parts and assistance are available from a Sears Service Center.

MAINTENANCE FREE BATTERY

HOW TO REMOVE THE BATTERY

To charge or clean the **battery**, remove the **battery** from the unit as follows.



WARNING: To prevent sparks, disconnect the black battery cable from the negative (-) terminal before you disconnect the red cable.

WARNING: The battery contains sulfuric acid which is harmful to the skin, eyes and clothing. If the acid gets on the body or clothing, wash with water.

1. Disconnect the **black cable** from the negative (-) terminal (Figure 16).
2. Disconnect the **red cable** from the **positive (+) terminal**.
3. To disconnect the **battery retainer** from the **battery tray**, push in on the lower end of the battery retainer.
4. Remove the **battery** from the right side of the unit.

HOW TO CLEAN THE BATTERY

1. Remove the **battery**.
2. Wash the **battery** with a solution of one gallon of water and four tablespoons of baking soda (sodium bicarbonate). Make sure the solution does not get into the battery cells.
3. Clean the **terminals** and the ends of the **cables** with a wire brush.
4. Install the **battery**.
5. To prevent corrosion, apply grease to the **battery terminals**.

HOW TO CHARGE THE BATTERY



WARNING: When you charge the battery, do not smoke. Keep the battery away from any sparks. The fumes from the battery acid can cause an explosion.

1. Before you charge the **battery**, remove the **battery**.
2. To charge the **battery**, use a 12 volt battery charger. Charge at a rate of 6 amperes for 1 hour.
3. Install the **battery**.



WARNING: To prevent sparks, fasten the red cable to the positive (+) terminal before you connect the black cable.

4. Fasten the **red cable** to the **positive (+) terminal** with the fasteners as shown.
5. Fasten the **black cable** to the **negative (-) terminal** with the fasteners as shown.

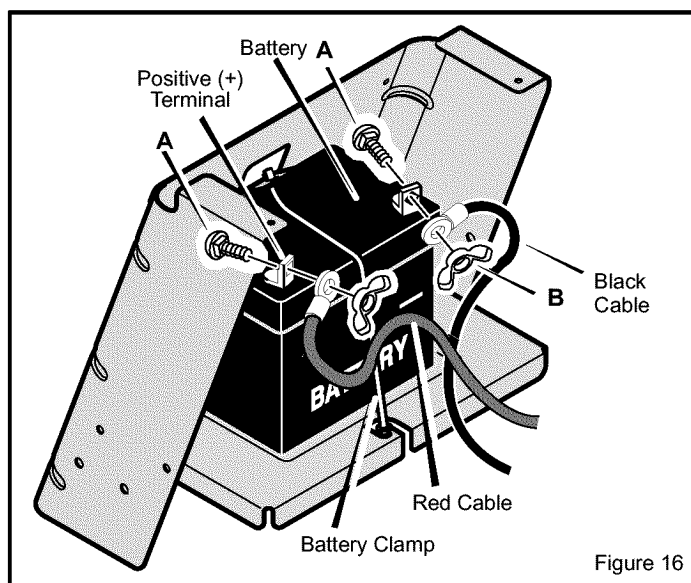

MAINTENANCE

WHERE TO LUBRICATE



Apply grease with a brush to the areas shown.



Lubricate the areas shown with engine oil.

NOTE: Apply grease to the steering gear assembly.

CAUTION: If the unit is operated in dry areas that have sand, use a dry graphite spray to lubricate the unit.

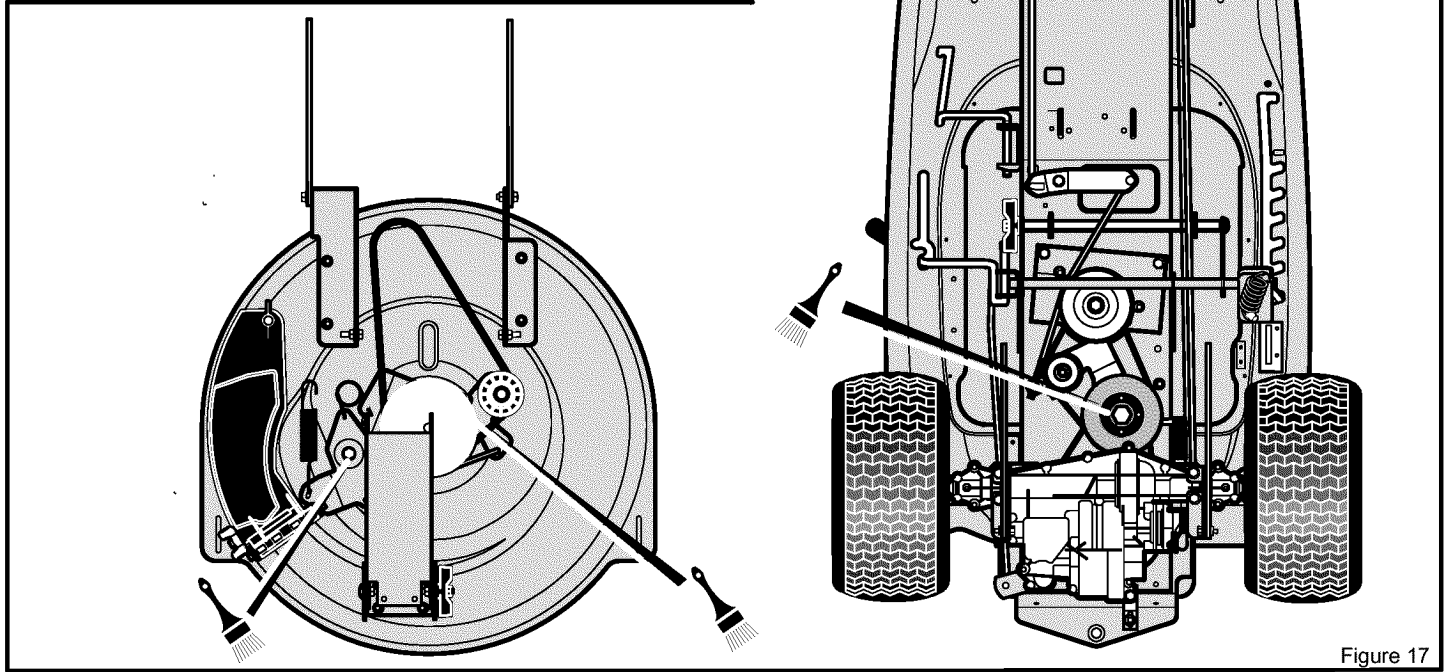

Figure 17

MAINTENANCE

ENGINE

HOW TO CHECK THE OIL

NOTE: Do not check the level of the oil while the engine runs.

1. Make sure the unit is level.
2. Clean the area around the **dipstick** (Figure 18). Remove the **dipstick**. Wipe the oil from the **dipstick**.
3. Insert the **dipstick** into the oil fill tube. Turn the **dipstick** clockwise until it is tight. Remove the **dipstick**. Check the oil level on the **dipstick**. The oil level must reach the FULL mark on the **dipstick**.
4. If necessary, add oil until the oil reaches the FULL mark on the **dipstick**. The quantity of oil needed from ADD to FULL is shown on the **dipstick**. Do not add too much oil.

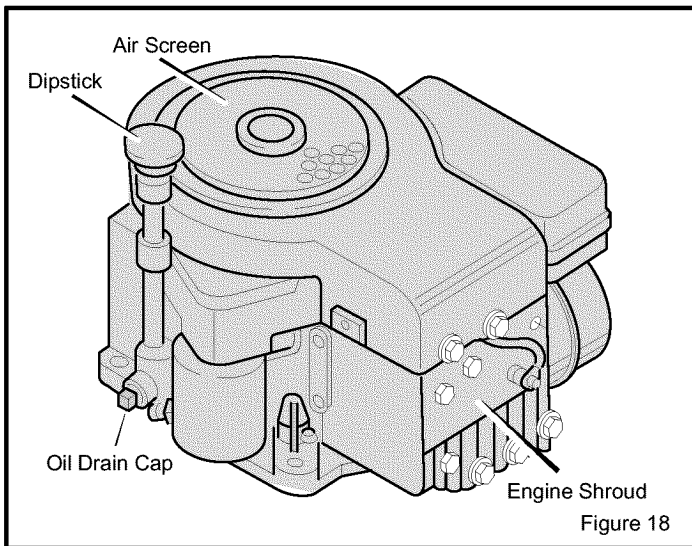

HOW TO CHANGE THE OIL

NOTE: Do not drain the oil from a cold engine. Before you drain the oil, let the engine run for several minutes. Make sure you do not get oil on the belts.

1. Remove the **oil drain cap**. Drain the oil completely from the engine. Install and tighten the **oil drain cap**.
2. Only use a high quality detergent oil rated with API service classification SF or SG. Select the oil's SAE viscosity grade according to the expected operating temperature using the temperature chart below:

Required SAE viscosity grades

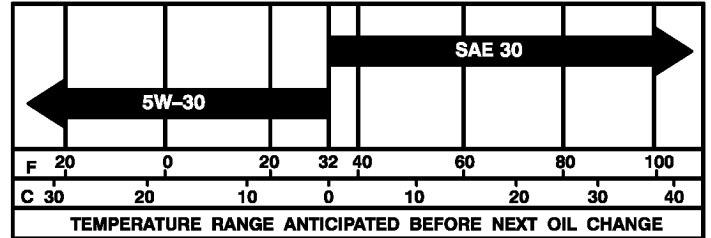

NOTE: Although multi-viscosity oils (5W30, 10W30, etc.) improve starting in cold weather, they will result in increased oil consumption when used above 32^o F. Check the engine oil level more frequently to avoid possible engine damage from running low on oil.

3. Clean the area around the **dipstick**. Remove the **dipstick**. Slowly pour approximately 32 ounces (1 quart) of oil into the oil extension tube.
4. Insert the **dipstick** into the oil extension tube. Turn the **dipstick** in a clockwise direction until it is tight. Remove the **dipstick**. Check the oil level on the **dipstick**. The oil level must reach the FULL mark on the **dipstick**.

HOW TO CLEAN THE COOLING SYSTEM

The engine is air cooled. The air that cools the engine enters through the **air screen** on top of the engine. Clean the engine every 100 hours or every year as follows.

1. Remove any grass, dirt or debris from the **air screen** with a cloth or brush.
2. Inspect the edge of the **engine shroud** for grass or debris. Remove any grass or debris visible at the bottom edge of the **engine shroud**.

HOW TO CHECK THE MUFFLER

Check the muffler every 50 hours. Make sure the muffler is correctly mounted and is not loose. If the muffler is worn or burnt, replace with a new muffler. A worn muffler is a fire hazard and can damage the engine.

F-020611L

If you mount a spark arrester to the muffler, also check the spark arrester when you check the muffler. If the spark arrester is worn or damaged, replace it with a new spark arrester purchased from a Sears Service Center.

MAINTENANCE

HOW TO CLEAN THE AIR FILTERS

Some engines have two filters, an outer **foam filter** around an inner **paper filter**. Clean the air filters every 50 hours. If you operate in dirty conditions, service more often.

NOTE: Never run the engine with the air filters removed. The air filters will help protect the engine against wear. For the correct replacement filter, see the parts list for the engine.

1. Remove the **knob** from the **cover** (Figure 19).
 2. Remove the **cover** from the air cleaner.
 3. Remove the **nut** from the filters.
 4. Remove the air filters.
 5. Clean the inside of the **base** and the **cover** with a cloth.
 6. Remove the **foam filter** from the **paper filter**.
 7. If equipped, wash the **foam filter** in a detergent and water solution. To remove the water solution, tightly roll the **foam filter** in a dry cloth. Remove the **foam filter** from the cloth. Completely dry the **foam filter**.
- CAUTION:** Do not wash the filters in gasoline or other solvents that will burn.
8. Evenly apply SAE 30W oil to the dry **foam filter**.
 9. To clean the **paper filter**, lightly tap the **paper filter** against a hard flat surface.
 10. If the **paper filter** is very dirty, replace the **paper filter**.

11. Assemble the air filters with the **nut**.
12. Install the **cover**. Fasten the **cover** with the **knob**.

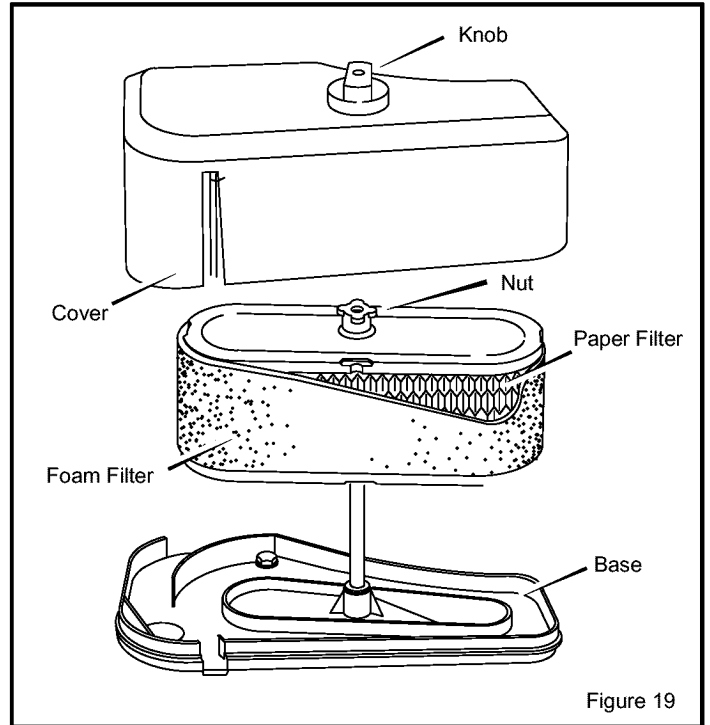

HOW TO CHECK THE SPARK PLUG

1. Check the gap of the **spark plug** with a **feeler gauge** (Figure 20). The correct gap is **0.030"**.
2. For easy starting and good performance, replace the **spark plug** every two years.

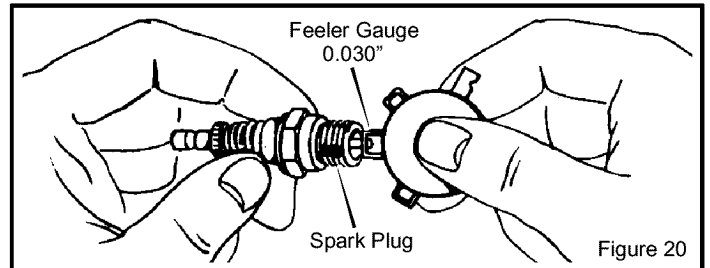

SERVICE AND ADJUSTMENT

HOW TO ADJUST THE REMOTE THROTTLE CONTROL

For the best engine performance, set the remote throttle control as follows.

1. Move the **remote throttle control** to the FAST position (see Figure 21).
2. The hole in the **governor control lever** (located just behind governor control plate) must align with the **hole in the governor control plate** (see Figure 22).
3. If the two holes do not line up, then loosen the **casing clamp screw** and move the **governor control rack** until the two holes are aligned.
4. Tighten the **casing clamp screw**.
5. Check the operation of the throttle. Move the throttle control to the STOP position.
6. The **governor control lever** must make good contact with **stop switch** (if equipped). Readjust if necessary.

IMPORTANT: Do not change the engine governor. If the engine governor needs an adjustment, go to the nearest Sears Service Center. They have the equipment and experience to make the adjustment.

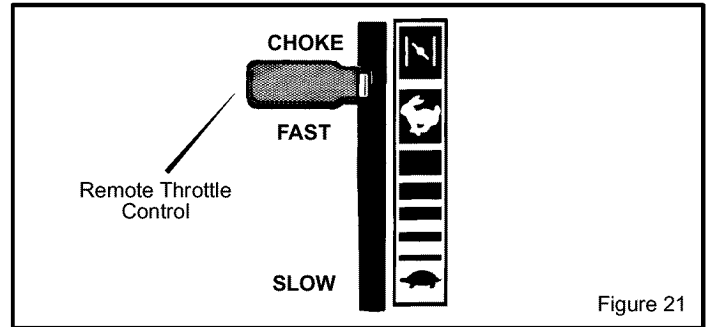

Figure 21

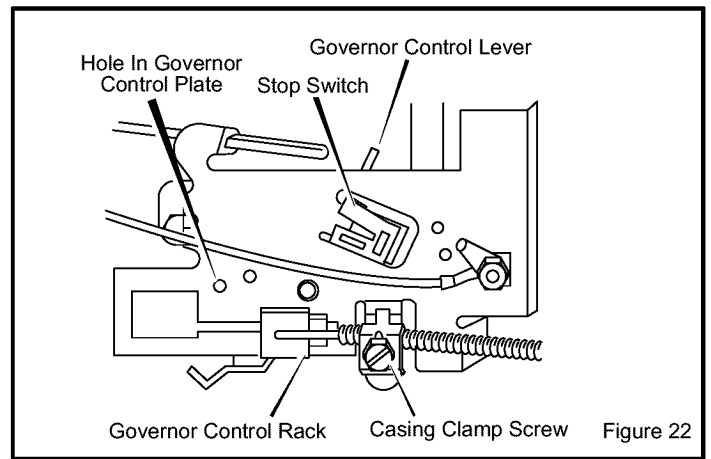

Figure 22

HOW TO ADJUST THE CARBURETOR

Differences in fuel, temperature, altitude or load may require minor carburetor adjustment. The air cleaner and its cover must be assembled to carburetor before starting engine.

The carburetor on this engine is equipped with an idle mixture valve with a limiter (see inset), which allows some minor adjustment, and an idle speed adjustment screw.

1. To adjust idle speed, start engine and warm up about 5 minutes.
2. With engine running, put the **remote throttle control** in SLOW position (see Figure 21).
3. Rotate the carburetor **throttle control lever** against the **idle speed screw** and hold it (see Figure 23). Then, turn the **idle speed screw** to obtain 1750 rpm (use a tachometer).
4. Rotate the **idle mixture valve** full travel clockwise and then counterclockwise.

NOTE: DO NOT remove limiter caps. DO NOT force beyond limits.

5. Then, position idle **idle mixture valve** in middle of travel.

F-020611L

6. Move the **remote throttle control** to the FAST position. The engine should accelerate smoothly. If it does not, adjust the **idle mixture valve** counterclockwise 1/8 turn.

NOTE: Engines operated at approximately 3000 to 5000 feet (900 to 1500 meters) above sea level may require a high altitude carburetor nozzle. If erratic performance is observed, contact a Sears Service Center for cost to install or to purchase a high altitude carburetor nozzle.

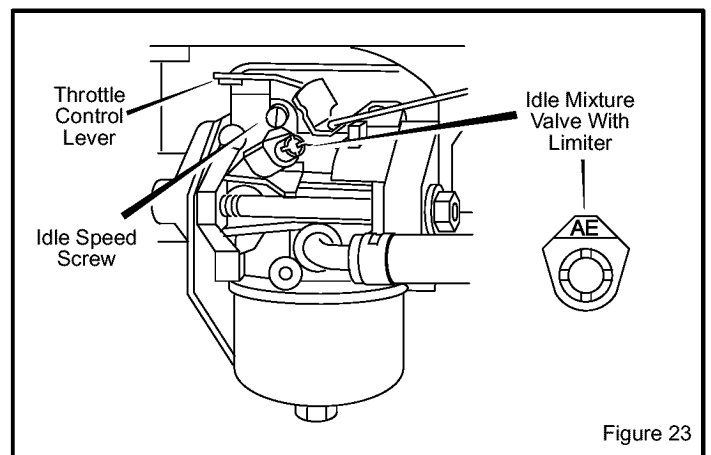

Figure 23

SERVICE AND ADJUSTMENT

HOW TO LEVEL THE MOWER HOUSING

If the mower housing is level, the blade will cut easier and the lawn will look better.



WARNING: Before you make an inspection, adjustment, or repair to the unit, disconnect the wire to the spark plug. Remove the spark plug wire to prevent the engine from starting by accident.

1. Make sure the unit is on a hard flat surface.
2. Check the air pressure in the tires. If the air pressure is incorrect, the mower housing will not cut level. Make sure the tires are inflated to: Front Tires 22 PSI (1.5 BAR), Rear Tires 14 PSI (1 BAR).
3. Open the **cover** (see Figure 24).
4. Move the **lift lever** to the LEVEL ADJUSTMENT position (see Figure 24).
5. Loosen the front and rear **adjuster knobs** (see Figure 24 and Figure 25). Make sure both sides of the mower housing are setting on a flat surface. Also, make sure the lift links and adjuster plates are loose and can easily move up or down.
6. Tighten the front and rear **adjuster knobs**. Make sure the **adjuster knobs** are tight. If necessary, use a wrench to tighten the **adjuster knobs**. For plastic **adjuster knobs**, tighten to a torque of 7 foot pounds (9,5 N-m). For metal **adjuster knobs**, tighten to a torque of 10 foot pounds (13,5 N-m).
7. Raise the **lift lever** from the LEVEL ADJUSTMENT position to a CUTTING HEIGHT position (Figure 26).
8. Close the **cover**.
9. Mow for a short distance. If the height of cut is not level, repeat the above steps.

CAUTION: Do not operate with the mower housing in the LEVEL ADJUSTMENT position. If you operate in the LEVEL ADJUSTMENT position, the mower housing and blades can be damaged.

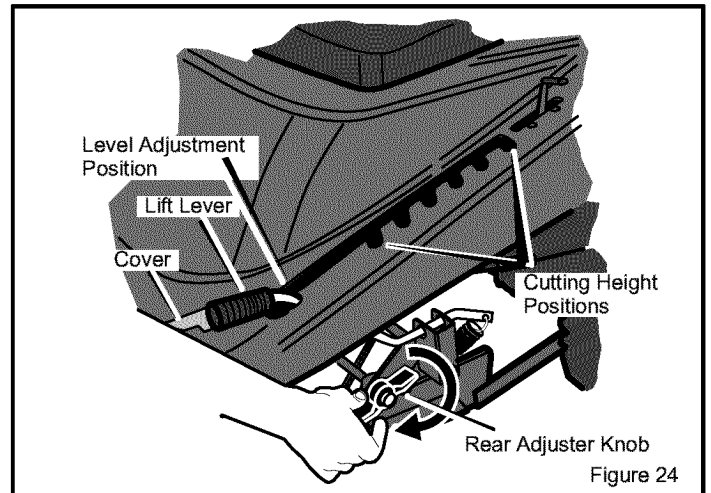

Figure 24

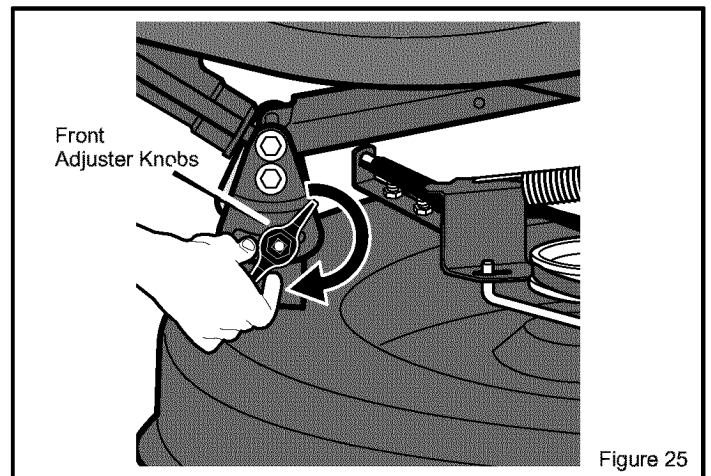

Figure 25

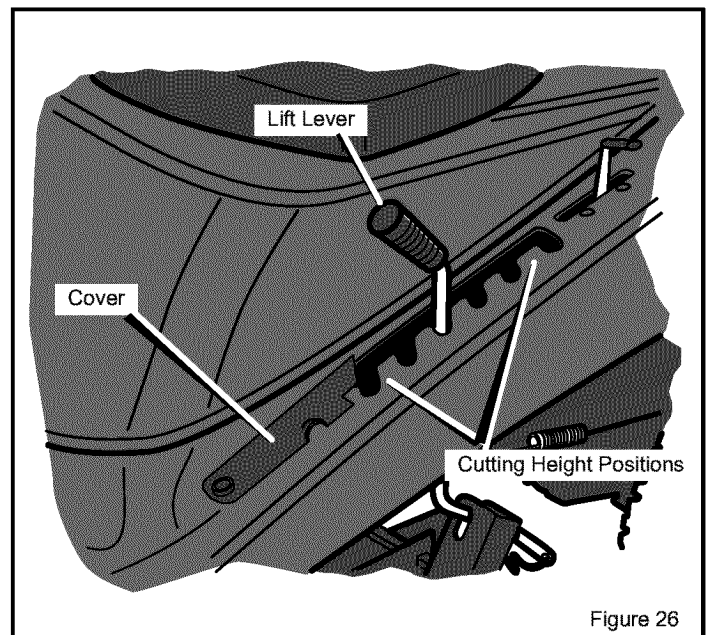

Figure 26

SERVICE AND ADJUSTMENT

HOW TO ADJUST THE ATTACHMENT CLUTCH



WARNING: To prevent an injury, the attachment clutch must operate correctly.

In normal usage, the **attachment clutch** will not require an adjustment. However, if the cutting performance decreases or the quality of cut is poor, make the following changes.

1. When you mow, make sure the throttle control is in the **FAST** position.
2. Move the **attachment clutch** to the **DISENGAGE** position (Figure 27).
3. Stop the engine. Disconnect the wire from the spark plug.

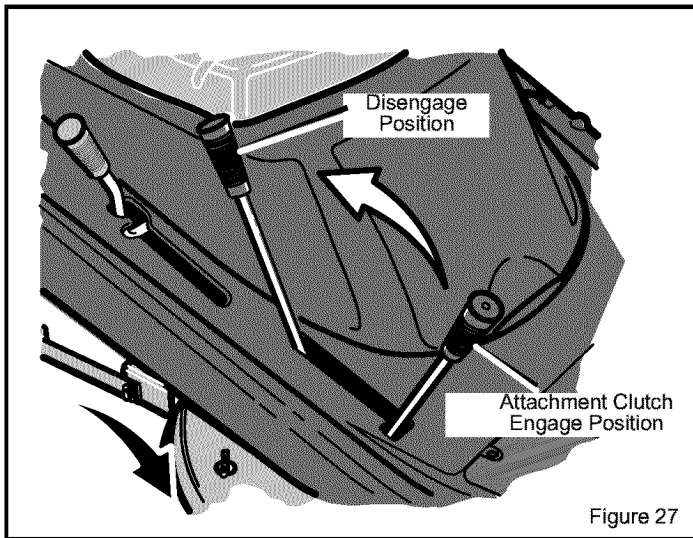

4. Check the blade(s). Keep a sharp edge on the blade(s). A blade that is not sharp will cause the tips of the grass to become brown.
5. If the quality of cut has not improved, replace the **mower drive belt**. See "How To Replace The Mower Drive Belt". If replacing the belt does not correct the problem, take the unit to a Sears or other qualified service center.
6. Move the **attachment clutch** to the **DISENGAGE** position. Stop the engine. Disconnect the wire from the spark plug.
7. Check the operation of the **blade brake**. Rotate the pulley with your hand. Make sure the **brake pad** is pressed tightly against the pulley (Figure 28).



WARNING: If the brake pad does not press tightly against the pulley, take the unit to a Sears or other qualified service center.

8. Move the **attachment clutch** to the **ENGAGE** position.
9. Check the pad for the **blade brake**. If the pad is excessively worn or damaged, replace the **brake pad** assemblies. Correct replacement parts and assistance are available from a Sears service center.
10. Attach the wire to the spark plug. Mow for a short distance and again check the operation of the **attachment clutch**.
11. When you move the **attachment clutch** to the **DISENGAGE** position, all movement will stop within five seconds. If there is movement of the belt or the blades continue to rotate, engage and disengage the **attachment clutch** five times to remove any excess rubber from a new **mower drive belt**. If you need assistance, take the unit to a Sears or other qualified service center.

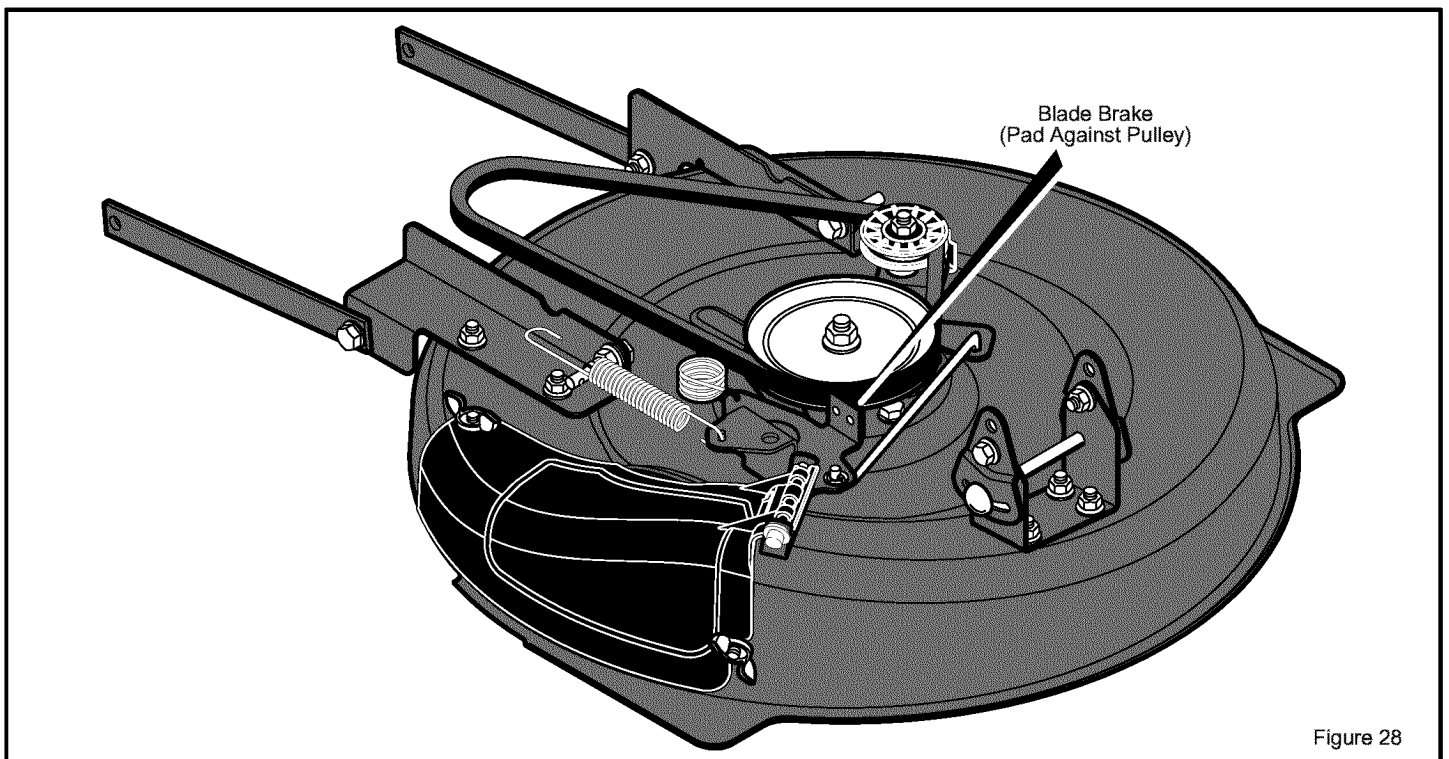

SERVICE AND ADJUSTMENT

HOW TO REMOVE THE MOWER HOUSING

1. Move the **attachment clutch** to the **DISENGAGE** position.
2. Move the **lift lever** to the level adjustment position (Figure 29).

NOTE: Make sure the lift lever is locked in the LEVEL ADJUSTMENT position.

3. Remove the hair pins and washers from the **rear suspension arms** (Figure 30). See illustrations "C" and "D".
4. Remove the hair pins and washers from the **suspension links**. See illustrations "A" and "B".
5. Disconnect the **extension spring** from the **blade control rod**. See illustration "E".
6. Disconnect the **front hanger** from the frame support. See illustration "F".
7. Remove the **mower drive belt** from the **stack pulley**. See illustration "G".
8. Pull the mower housing away from the right side of the unit.
9. To operate without the mower housing, move the lift lever to the **TOP** position.

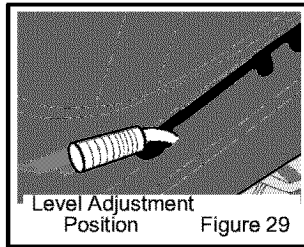

HOW TO INSTALL THE MOWER HOUSING

1. Push the mower housing under the right side of the unit.
2. Put the **mower drive belt** around the **stack pulley**. Make sure the "V" side of the **mower drive belt** is against the **stack pulley**. Also, make sure the **mower drive belt** is not twisted.
3. Attach the **front hanger** to the frame support with the **hanger rod**. Fasten with the fasteners as shown. See illustration "F".
4. Make sure the **mower drive belt** is between the **stack pulley** and the two **belt guides**. See illustration "G".
5. Attach the **suspension links** to the **lifter assembly**. Fasten with the washers and hair pins. See illustrations "A" and "B".
6. Attach the **rear suspension arms** to the suspension brackets. Fasten with the washers and hair pins. See illustrations "C" and "D".
7. Attach the **extension spring** to the **blade control rod**. See illustration "E".
8. Move the **attachment clutch** to the **ENGAGE** position. Make sure the **mower drive belt** is inside all the **belt guides** and is also below the **spacer tube**.
9. Make sure the mower housing is level. See the instructions on "How To Level The Mower Housing".
10. Check the operation of the **attachment clutch**. See the instructions on "How To Adjust The Attachment Clutch".

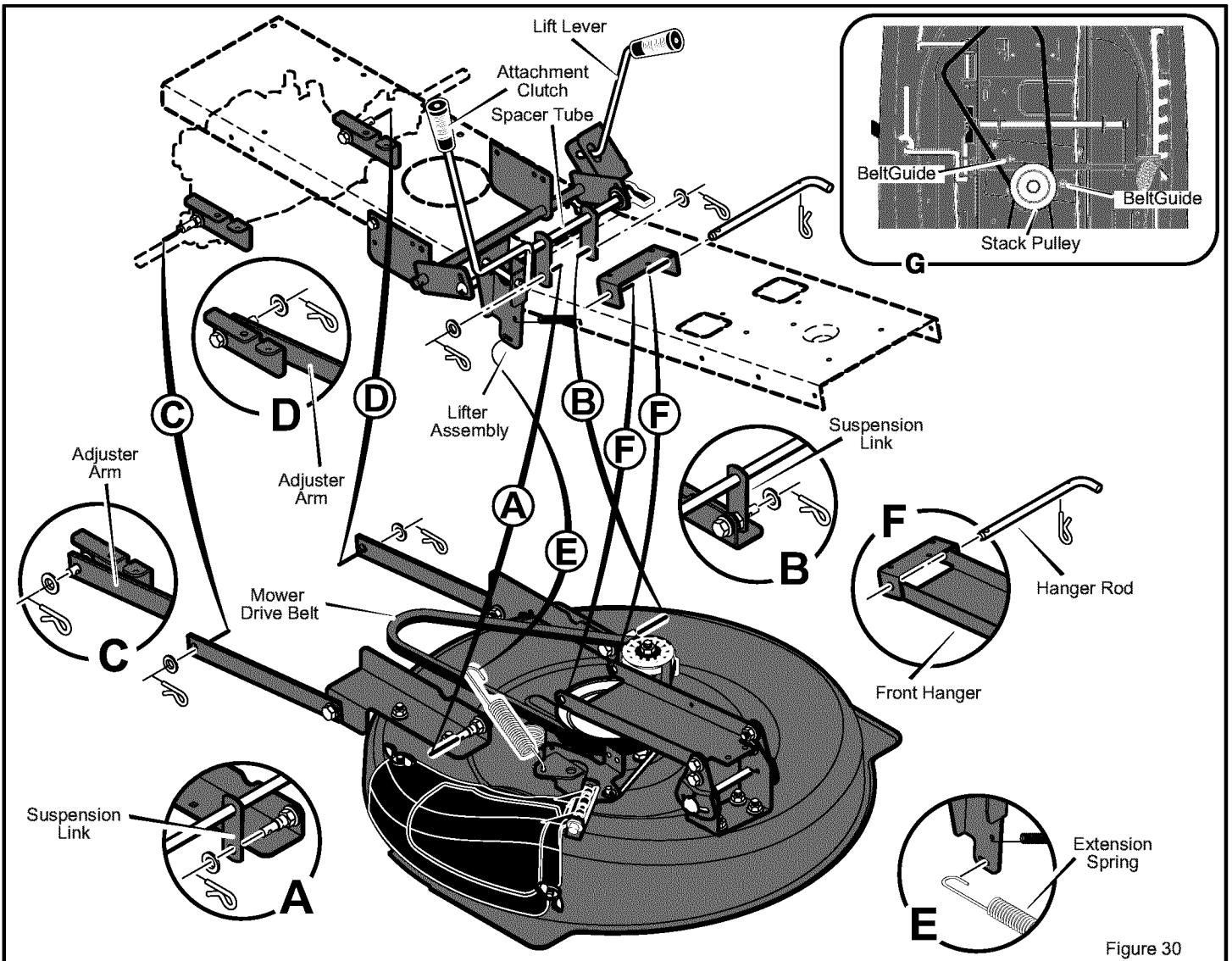

SERVICE AND ADJUSTMENT

HOW TO REPLACE THE MOTION DRIVE BELTS

ENGINE DRIVE BELT REMOVAL

1. Remove the mower housing. See the instructions on "How To Remove The Mower Housing".
2. Remove the **engine drive belt** from the **idler pulley** (see Figure 31). If necessary, remove the **idler pulley**.
3. Remove the **engine drive belt** from the **variator pulley**. If necessary, loosen the **belt guides** at the **variator pulley**.
4. Remove the **engine drive belt** from the **stack pulley**.

NOTE: Because of the width of the engine drive belt, the belt must be twisted and then pulled downward to slip between the stack pulley and the belt guides.

ENGINE DRIVE BELT INSTALLATION

1. To install the **engine drive belt**, reverse the above steps.
2. Make sure that the **engine drive belt** is installed correctly and is inside of all the **belt guides** (see Figure 31).
3. Make sure that the fasteners for the **belt guides** are tight.
4. Install the mower housing. See the instructions on "How To Install The Mower Housing".

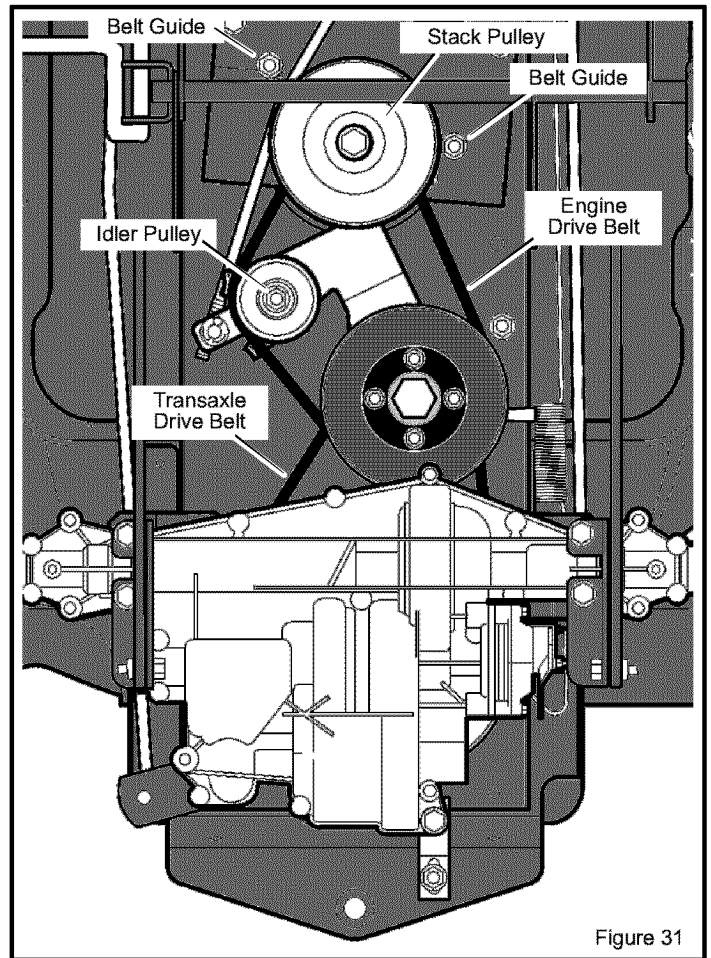

Figure 31

SERVICE AND ADJUSTMENT

TRANSAXLE DRIVE BELT REMOVAL

1. Remove the mower housing. See the instructions on "How To Remove The Mower Housing".
2. Remove the **engine drive belt**. See "Engine Drive Belt Removal".
3. The rear of the unit must be supported with the rear wheels off of the ground so that the transaxle can be lowered. Set the rear of the unit on jackstands or a similar type of support. Do not set the transaxle on the jackstands; set the frame on the jackstands.
4. Remove the **hair pin** and **washer** from the **adjustable nut** (see Figure 32). Remove the **adjustable nut** from the **shift yoke**.
5. Remove the **carriage bolt** from the **torque strap** (see Figure 33).
6. To relieve tension on the **transaxle drive belt**, depress the clutch/brake pedal and set the parking brake.
7. Remove the **transaxle drive belt** from the **transaxle idler pulley** (see Figure 34).
8. Remove the **transaxle drive belt** from the **variator pulley**.
9. Loosen the **mounting bolts** on the left side of the **transaxle**. Loosen until the mounting nuts are at the end of the **mounting bolts** (see Figure 33).
10. Remove the **mounting bolt** from the right side of the **transaxle**. This will allow the right side of the **transaxle** to drop down and provide clearance for the **transaxle drive belt**.

TRANSAXLE DRIVE BELT INSTALLATION

1. To install the **engine drive belt**, reverse the above steps.
2. Make sure that the **transaxle drive belt** is installed correctly and is inside of all the **belt guides**.
3. Make sure that all fasteners, all the mounting bolts, and all the **belt guides** are tight.
4. Install the **engine drive belt**. See "Engine Drive Belt Installation".
5. Install the mower housing. See the instructions on "How To Install The Mower Housing".
6. Check the operation of the drive system. See "How To Check And Adjust The Clutch" and also "How To Adjust The Speed Control Pedal".

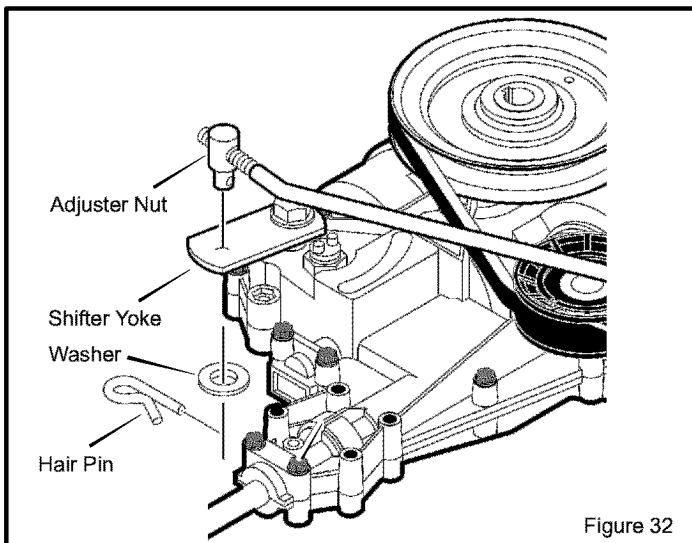

Figure 32

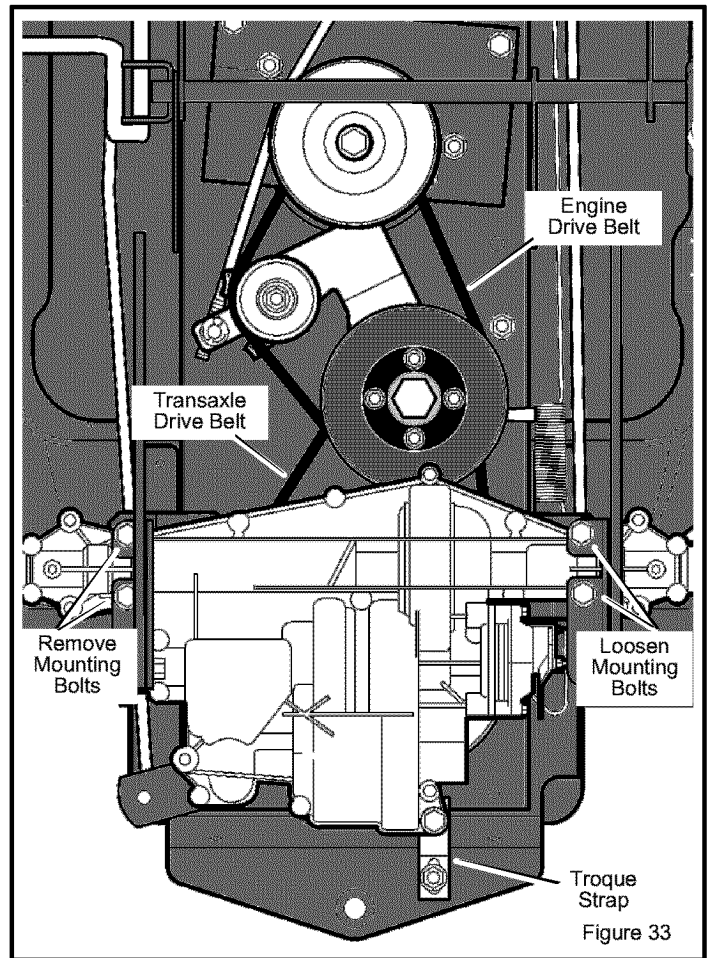

Figure 33

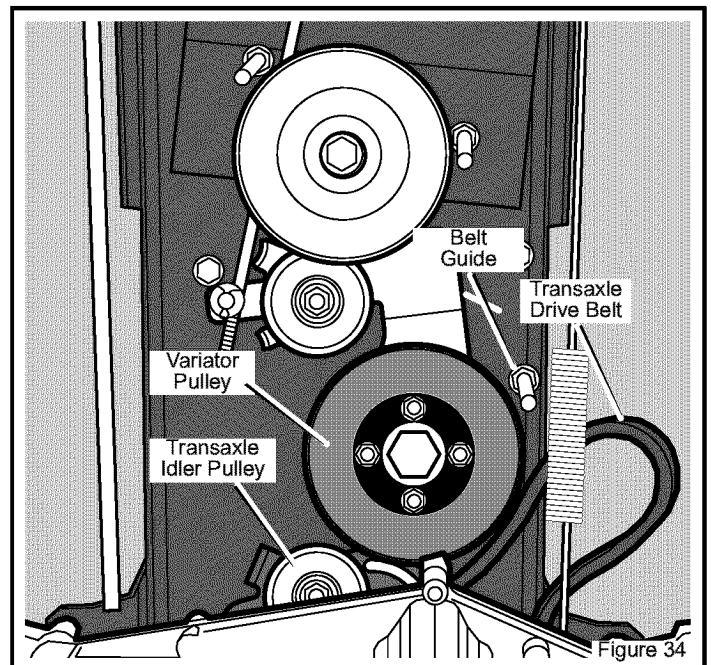

Figure 34

SERVICE AND ADJUSTMENT

HOW TO REPLACE THE MOWER DRIVE BELT

1. Remove the mower housing. See the instructions on "How To Remove The Mower Housing".
2. Pull the **belt retainer** away from the **idler pulley** and remove the **mower drive belt** (Figure 35).
3. Pull the **brake pad** away from the **jackshaft pulley** and remove the **mower drive belt**.
NOTE: Replace the mower drive belt with an original equipment belt purchased from a Sears Service Center.
4. Install the new **mower drive belt**. Pull the **brake pad** away from the **jackshaft pulley**. Put the **mower drive belt** around the **jackshaft pulley**.
5. Pull the **belt retainer** away from the **idler pulley**. Put the **mower drive belt** around the **idler pulley**.
6. Make sure the "V" side of the **mower drive belt** is against the **jackshaft pulley** and the **idler pulley**.
7. Install the mower housing. See the instructions on "How To Install The Mower Housing".
8. Before you mow, check the attachment clutch. See the instructions on "How To Adjust The Attachment Clutch".

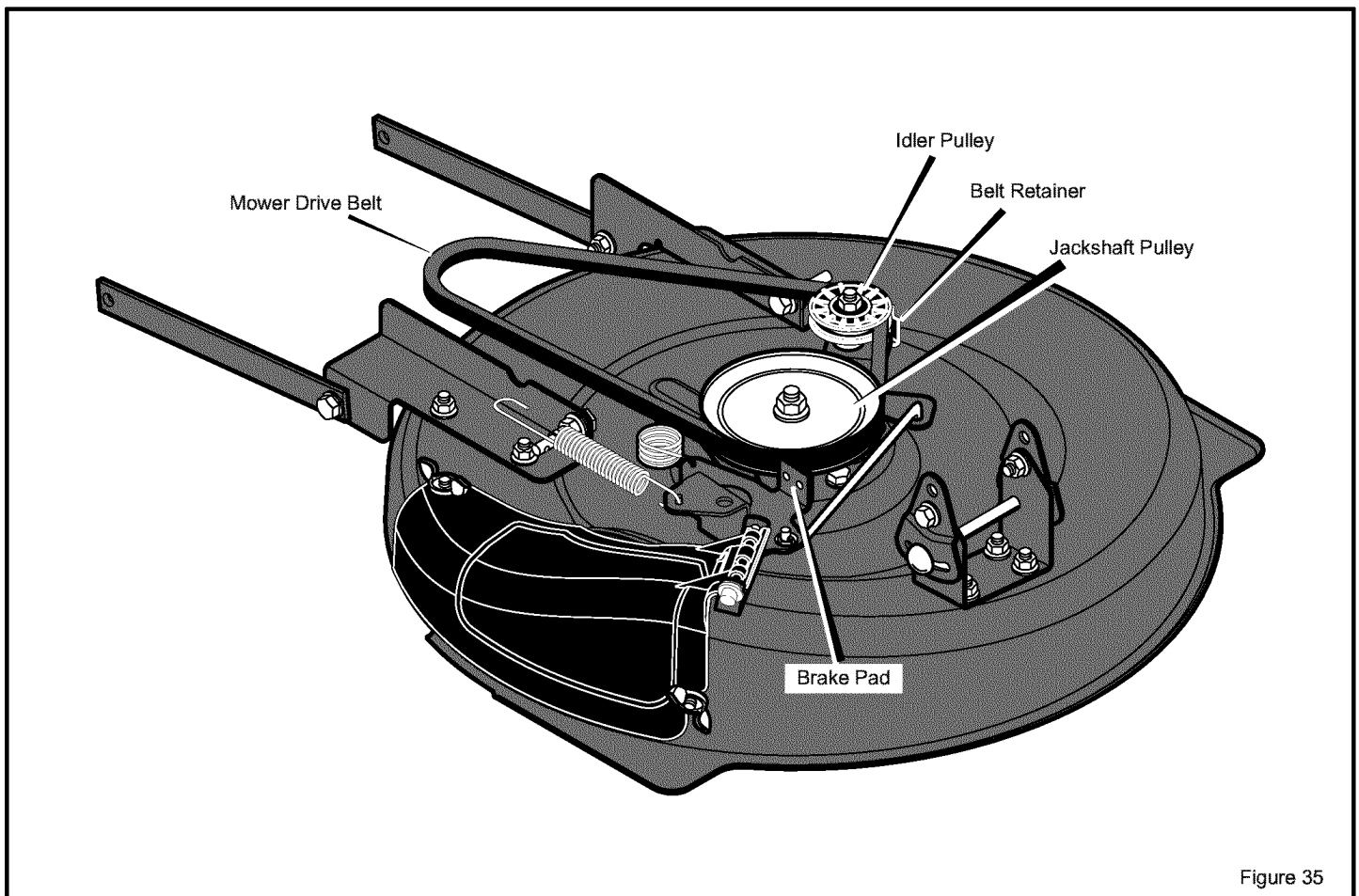

Figure 35

SERVICE AND ADJUSTMENT

HOW TO ADJUST THE SPEED CONTROL PEDAL



WARNING: Before you make an inspection, adjustment, or repair to the unit, disconnect the wire to the spark plug. Remove the wire from the spark plug to prevent the engine from starting by accident.

If a drive belt becomes worn or after installation of a new drive belt, the speed control pedal may need an adjustment. There are two indications that an adjustment is needed. *First*, when the speed control pedal is fully depressed the unit does not achieve top speed. *Second*, when the speed control pedal is released, the unit does not come to a complete stop.

1. Check the routing of the **engine drive belt**. Make sure the belt is installed correctly and is inside all the **belt guides**.
2. Remove the cotter pin and washer from the **adjustable nut** (Figure 36).
3. If the unit is not achieving top speed, then turn the **adjustable nut** towards the end of the **drive link**. If the unit does not come to a complete stop, then turn the **adjustable nut** toward the center of the **drive link**.
4. Assemble the **adjustable nut** to the **pivot link**. Fasten with the **washer** and **cotter pin**.

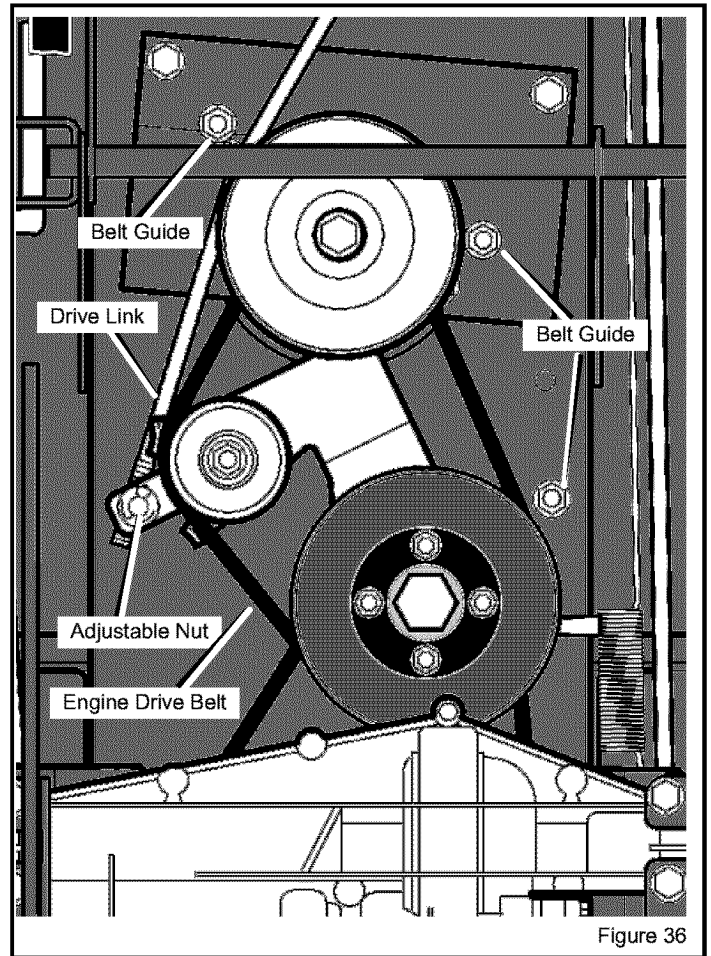

SERVICE AND ADJUSTMENT

HOW TO CHECK AND ADJUST THE CLUTCH

If the engine drive belt is loose, the clutch will slip when; (1) going up a hill, (2) pulling a heavy load, or (3) the unit will not move forward. Adjust the clutch as follows.



WARNING: Before you make an inspection, adjustment, or repair to the unit, disconnect the wire to the spark plug. Remove the wire from the spark plug to prevent the engine from starting by accident.

1. Check the routing of the engine drive belt. Make sure the belt is installed correctly and is inside all the belt guides.
2. Remove the **cotter pin** and **washer** from the **adjustable nut** (Figure 37).
3. Disconnect the **adjustable nut** from the **clutch pivot link**.
4. Pull the **clutch pivot link** forward until tight.
5. Pull the **clutch rod** toward the rear and turn the **adjustable nut** until the **adjustable nut** is aligned with the rear of the slot.
6. Assemble the **adjustable nut** to the **clutch pivot link**. Fasten with the **washer** and **cotter pin**.
7. If the belt still slips after the clutch has been adjusted, then the motion drive belt is worn or damaged and must be replaced. See "How To Replace The Motion Drive Belts".

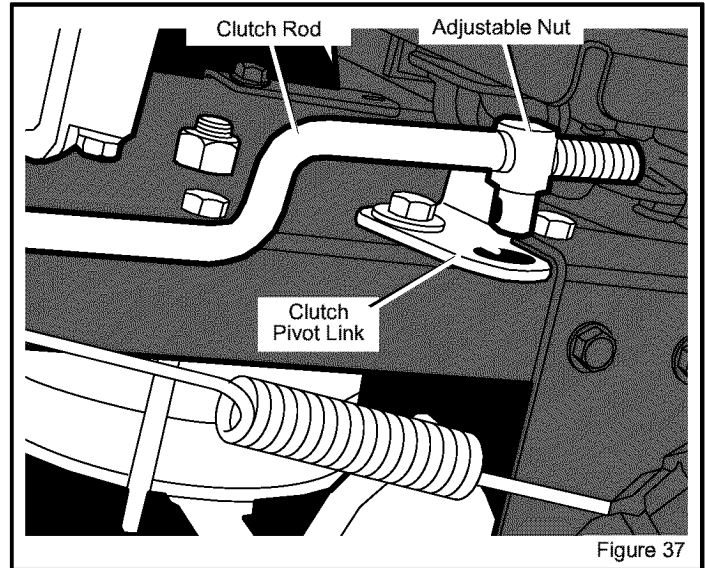

Figure 37

HOW TO ADJUST THE SHIFT LEVER

If the NEUTRAL position on the shift lever does not match neutral on the gearbox, adjust the shift lever as follows.

1. Stop the engine.
2. Disconnect the **adjuster nut** from the **shifter yoke** (Figure 38).
3. Make sure the shift lever is in the NEUTRAL position.
4. Push the unit forward. Make sure the gearbox is in neutral.
5. To align the **adjuster nut** with the hole in the **shifter yoke**, turn the **adjuster nut**.
6. Connect the **adjuster nut** to the **shifter yoke**.
7. Make sure the NEUTRAL position on the shift lever matches neutral on the gearbox.

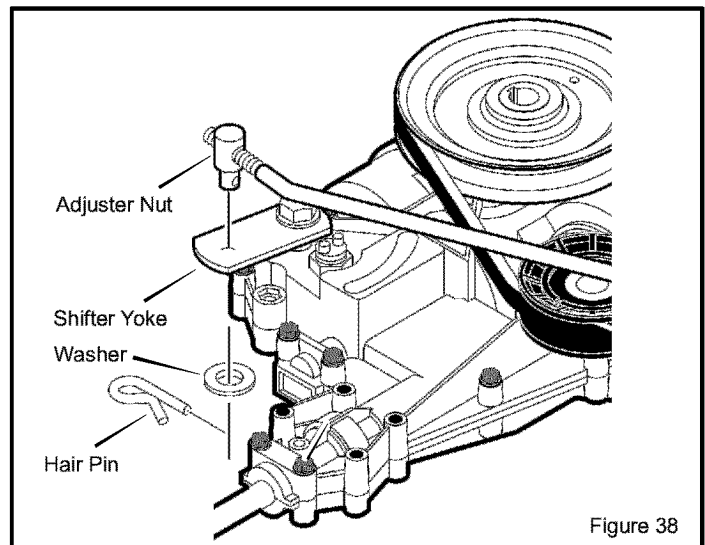

Figure 38

SERVICE AND ADJUSTMENT

HOW TO INSTALL THE WHEELS

If the wheels must be removed for service, make sure they are installed as follows.

Front Wheel

1. Make sure the **valve stem** is to the outside of the tractor. Slide the **front wheel** on the **spindle** (See Figure 39).
2. Fasten the **front wheel** with **washer** and **cotter pin**. Bend the ends of the **cotter pin** apart to keep the **front wheel** on the **spindle**.
3. If your model has **hub caps**, install the **hub caps**. Make sure the **washers** hold the **hub caps** in place.

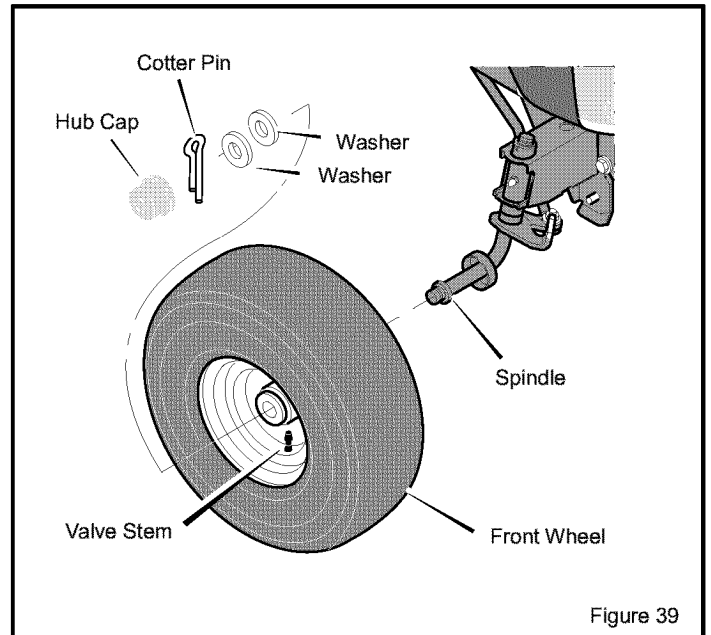

Rear Wheel

1. Install the **washers** and **spacer** onto the **axle** as shown in Figure 40.
2. Mount the **square key** in the **key slot** (See Figure 40).
3. Make sure the **valve stem** is to the outside of the tractor. Align the slot in the **rear wheel** with the **square key**. Slide the **rear wheel** on the **axle**.
4. Fasten the **rear wheel** with **washer** and **e-ring**.
5. If your model has **hub caps**, install the **hub caps**. Make sure the **washers** hold the **hub caps** in place.

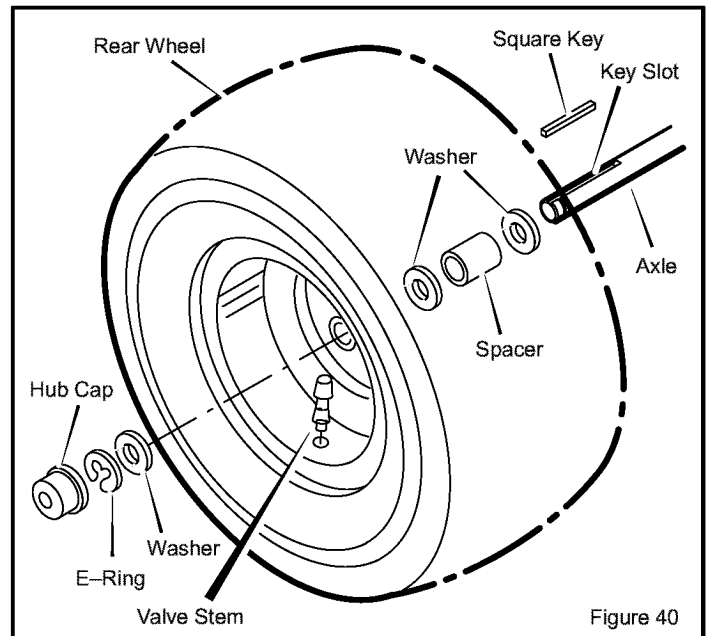

SERVICE AND ADJUSTMENT

HOW TO REPLACE THE FUSE

If the fuse is blown, the engine will not start. The location of the fuse is next to the battery. Remove the fuse and replace with a 15 amp. automotive fuse (Figure 41).

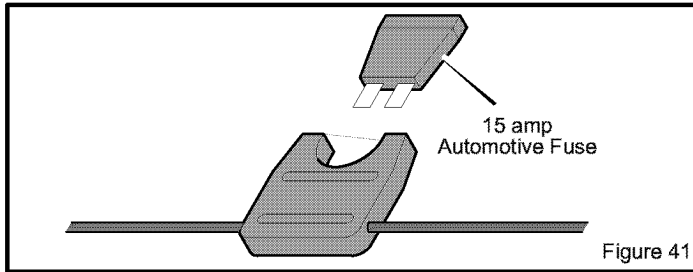

HOW TO CLEAN THE MOWER HOUSING



WARNING: Before you clean the mower housing, stop the engine and disconnect the wire to the spark plug.

Grass and other debris on top of the mower housing can keep the belt from working correctly. For safety and correct operation, frequently clean the top of the mower housing. Remove grass and debris from around the pulleys and other moving parts.

1. Move the lever for the attachment clutch to the ENGAGE position.
2. Clean the top of the mower housing.
3. Move the lever for the attachment clutch to the DISENGAGE position.
4. Again clean the top of the mower housing.
5. After you cut the grass, clean the bottom of the mower housing.

FRONT WHEEL ALIGNMENT

The alignment of the front wheels cannot be adjusted. If the steering is damaged and the alignment has changed, take the unit to your nearest Sears Service Center.

STORAGE (over 30 days)

At the end of each year, prepare the unit for storage as follows.

GENERAL INSPECTION

1. Inspect the belts. If the belts are damaged or worn, replace with replacement belts from the factory. See the belt replacement instructions in the Service And Adjustment section.
2. Make sure all nuts, bolts and screws are tight. Inspect moving parts for damage, breakage and wear. Replace if necessary.

MOWER HOUSING

1. Clean the mower housing. See "How To Clean The Mower Housing".

LUBRICATE THE UNIT

See the "Where To Lubricate" instructions in the Maintenance section.

THE ENGINE

1. Clean the dirt and grass from the engine.
2. Change the oil. See the instructions, "How To Change The Oil".
3. Check the air screen. See the instructions, "How To Clean The Cooling System".
4. Check the spark plug. See the instructions, "How To Check The Spark Plug".

THE FUEL SYSTEM



WARNING: Do not drain the gasoline inside a building or near a fire. Do not smoke because the fumes from the fuel can cause an explosion.

It is important to prevent gum deposits from forming in essential fuel system parts such as the carburetor, fuel filter, fuel hose or tank during storage. Also, alcohol blended fuels (called gasohol or using ethanol or methanol) can attract moisture which leads to separation and formation of acids during storage. Acidic gas can damage the fuel system of an engine while in storage.

To avoid engine problems, the fuel system should be emptied before storage of 30 days or longer. Follow these instructions:

NOTE: Fuel stabilizer (like STA-BIL) is an acceptable alternative in reducing the formation of fuel gum in the fuel tank and the gasoline storage container. Always follow the mix ratio located on the container of stabilizer. Run the engine at least 10 minutes after adding the stabilizer to allow the stabilizer to reach the carburetor. Do not drain the fuel tank and carburetor if stabilizer is used.

If you do not use a stabilizer, do the following:

1. Start the engine.
2. Run the engine until the fuel tank and the carburetor are out of fuel and the engine stops.
3. Do not leave fuel in the fuel tank or the carburetor. The fuel can damage the function of the fuel system.
4. After storage, make sure you use fresh fuel.

THE BATTERY

1. Remove the battery.
2. Clean the battery terminals of any deposits.
3. Charge the battery. See the instructions on "How To Charge The Battery".
4. Store the battery in a cool, dry place.

NOTE: After a long time in storage, charge the battery.

TROUBLESHOOTING CHART

PROBLEM: The engine will not start.

1. Follow the steps, "How To Start The Engine" in this book.
2. Electric-Start Models: Clean the battery terminals. Tighten the cables.
3. Drain the fuel tank. Clean the fuel line. Replace the fuel filter.
4. Remove the spark plug(s). Move the throttle to the SLOW position. Turn the ignition key to the ON position. Try to start the engine several times. Install the spark plug.
5. Replace the spark plug.
6. Adjust the carburetor.

PROBLEM: The engine will not turn over.

1. Follow the steps, "How To Start The Engine" in this book.
2. Electric-Start Models: Check the level of the acid in the battery. If needed, add water. Charge the battery.
3. Replace the fuse.
4. Check the wiring harness for damage or a loose connection. Repair the damaged wire.
5. Electric-Start Models: replace the solenoid. Recoil-Start Models: replace the module.

PROBLEM: The engine is difficult to start.

1. Adjust the carburetor.
2. Replace the spark plug.
3. Replace the fuel filter.

PROBLEM: The engine does not run smooth or has a loss of power.

1. Check the oil.
2. Clean the air filter.
3. Clean the air screen.
4. Replace the spark plug.
5. The engine is working too hard. Use a lower gear.
6. Adjust the carburetor.
7. Replace the fuel filter.

PROBLEM: The engine does not run smooth at fast speed.

1. Replace the spark plug.
2. Adjust the throttle control.
3. Clean the air filter.
4. Replace the fuel filter.

PROBLEM: The engine stops when the blades are engaged.

1. Check the wiring harness for damage or a loose connection. Repair the damaged wire.

PROBLEM: On slopes, the engine stops.

1. Mow up and down slopes. Never mow across a slope.

PROBLEM: The engine will not idle.

1. Replace the spark plug.
2. Clean the air filter.
3. Adjust the carburetor.
4. Adjust the throttle control.
5. Drain the fuel tank. Clean the fuel line. Replace the fuel filter.

PROBLEM: A hot engine causes a decrease in power.

1. Clean the air screen.

2. Check the oil.
3. Adjust the carburetor.
4. Replace the fuel filter.

PROBLEM: Excessive vibration.

1. Replace the blade.
2. Check for loose engine bolts.
3. Decrease the air pressure in the tires.
4. Adjust the carburetor.
5. Check for a damaged belt or damaged pulley. Replace the damaged parts.

PROBLEM: The grass does not discharge correctly.

1. Stop the engine. Clean the mower housing.
2. Raise the height of cut.
3. Replace or sharpen the blade(s).
4. Move the shift lever to a slower speed.
5. Move the throttle control to the FAST position.
6. Replace the spring for the blade idler.

PROBLEM: The mower housing does not cut level.

1. Check the air pressure in the tires.
2. Adjust the level of the mower housing.
3. Check the front axle. If the front axle does not freely pivot, loosen the axle bolt(s).

PROBLEM: The mower blades will not rotate.

1. Check the mower drive belt. Make sure the belt is installed correctly.
2. Replace the mower drive belt.

PROBLEM: The unit will not move when the clutch is engaged.

1. Check the motion drive belt. Make sure the belt is installed correctly.
2. Adjust the clutch.
3. Replace the motion drive belt.

PROBLEM: The unit moves slower or stops when the clutch is engaged.

1. Adjust the clutch.
2. Replace the motion drive belt.

PROBLEM: When the clutch/brake pedal is released, belt noise can be heard.

1. Temporary belt noise does not change the operation of the unit. If belt noise is continuous, check the routing of the belt. Make sure the belt is inside all belt guides.
2. If the noise is continuous, adjust the clutch.

PROBLEM: The rear wheels spin over uneven terrain.

1. Check the front axle. If the front axle does not freely pivot, loosen the axle bolt(s).

PROBLEM: The transaxle is difficult to shift between gears with the engine running and the clutch depressed.

1. Check the clutch adjustment to make sure the belt stops when the clutch pedal is depressed with the transaxle in (N) neutral.
2. Check the belt guides around the transaxle drive pulley. Make sure the belt guides do not touch the pulley.

SEARS, ROEBUCK AND CO.

Federal and California Emission Control Systems Limited Warranty Small Off-Road Engines

CALIFORNIA & US EPA EMISSION CONTROL WARRANTY STATEMENT

The U. S. Environmental Protection Agency ("EPA"), the California Air Resources Board ("CARB") and Sears, Roebuck and Co. are pleased to explain the Federal and California Emission Control Systems Warranty on your new small off-road engine. In California, new 1995 and later small off-road engines must be designed, built and equipped to meet the State's stringent anti-smog standards. In other states, new 1997 and later model year engines must be designed, built and equipped, at the time of sale, to meet the U.S. EPA regulations for small non-road engines. Sears, Roebuck and Co. will warrant the emission control system on your small off-road engine for the periods of time listed below, provided there has been no abuse, neglect, unapproved modification, or improper maintenance of your small off-road engine.

Your emission control system may include parts such as the carburetor, ignition system and exhaust system. Also included may be the compression release system and other emission-related assemblies.

Where a warrantable condition exists, Sears, Roebuck and Co. will repair your small off-road engine at no cost to you for diagnosis, parts and labor.

MANUFACTURER'S EMISSION CONTROL SYSTEM WARRANTY COVERAGE

Emission control systems on 1995 and later model year California small off-road engines are warranted for two years as hereinafter noted. In other states, 1997 and later model year engines are also warranted for two years. If, during such warranty period, any emission-related part on your engine is defective in materials or workmanship, the part will be repaired or replaced by Sears, Roebuck and Co.

OWNER'S WARRANTY RESPONSIBILITIES

As the small off-road engine owner, you are responsible for the performance of the required maintenance listed in your Owner's Manual, but Sears, Roebuck and Co. will not deny warranty solely due to the lack of receipts or for your failure to provide written evidence of the performance of all scheduled maintenance.

As the small off-road engine owner, you should, however, be aware that Sears, Roebuck and Co. may deny you warranty coverage if your small off-road engine or a part thereof has failed due to abuse, neglect, improper maintenance or unapproved modifications.

You are responsible for presenting your small off-road engine to a Sears, Roebuck and Co. Authorized Service Outlet as soon as a problem exists. The warranty repairs should be completed in a reasonable amount of time, not to exceed 30 days.

Warranty service can be arranged by contacting either a Sears, Roebuck and Co. Authorized Service Outlet, or by contacting Sears, Roebuck and Co. at 1-800-473-7247.

IMPORTANT NOTE

Esta This warranty statement explains your rights and obligations under the Emission Control System Warranty ("ECS Warranty") which is provided to you by Sears, Roebuck and Co. pursuant to California law. See also the Sears, Roebuck and Co. Limited Warranties for Sears, Roebuck and Co. which is enclosed therewith on a separate sheet and also is provided to you by Sears, Roebuck and Co. The ECS Warranty applies only to the emission control system of your new engine. To the extent that there is any conflict in terms between the ECS Warranty and the Sears, Roebuck and Co. Warranty, the ECS Warranty shall apply except in any circumstances in which the Sears, Roebuck and Co. Warranty may provide a longer warranty period. Both the ECS Warranty and the Sears, Roebuck and Co. Warranty describe important rights and obligations with respect to your new engine.

Warranty service can only be performed by a Sears, Roebuck and Co. Authorized Service Outlet. At the time of requesting warranty service, evidence F-020611L

must be presented of the date of sale to the original purchaser. The purchaser shall pay any charges for making service calls and/or for transporting the products to and from the place where the inspection and/or warranty work is performed. The purchaser shall be responsible for any damage or loss incurred in connection with the transportation of any engine or any part(s) thereof submitted for inspection and/or warranty work.

If you have any questions regarding your warranty rights and responsibilities, you should contact Sears, Roebuck and Co. at 1-800-473-7247.

EMISSION CONTROL SYSTEM WARRANTY

Emission Control System Warranty ("ECS Warranty") for 1995 and later model year California small off-road engines (for other states, 1997 and later model year engines):

A. APPLICABILITY: This warranty shall apply to 1995 and later model year California small off-road engines (for other states, 1997 and later model year engines). The ECS Warranty Period shall begin on the date the new engine or equipment is delivered to its original, end-use purchaser, and shall continue for 24 consecutive months thereafter.

B. GENERAL EMISSIONS WARRANTY COVERAGE: Sears, Roebuck and Co. warrants to the original, end-use purchaser of the new engine or equipment and to each subsequent purchaser that each of its small off-road engines is:

1. Designed, built and equipped so as to conform with all applicable regulations adopted by the Air Resources Board pursuant to its authority in Chapters 1 and 2, Part 5, Division 26 of the Health and Safety Code, and

2. Free from defects in materials and workmanship which, at any time during the ECS Warranty Period, will cause a warranted emissions-related part to fail to be identical in all material respects to the part as described in the engine manufacturer's application for certification.

C. The ECS Warranty only pertains to emissions-related parts on your engine, as follows:

1. Any warranted, emissions-related parts which are not scheduled for replacement as required maintenance in the Owner's Manual shall be warranted for the ECS Warranty Period. If any such part fails during the ECS Warranty Period, it shall be repaired or replaced by Sears, Roebuck and Co. according to Subsection 4 below. Any such part repaired or replaced under the ECS Warranty shall be warranted for any remainder of the ECS Warranty Period.

2. Any warranted, emissions-related part which is scheduled only for regular inspection as specified in the Owner's Manual shall be warranted for the ECS Warranty Period. A statement in such written instructions to the effect of "repair or replace as necessary", shall not reduce the ECS Warranty Period. Any such part repaired or replaced under the ECS Warranty shall be warranted for the remainder of the ECS Warranty Period.

3. Any warranted, emissions-related part which is scheduled for replacement as required maintenance in the Owner's Manual, shall be warranted for the period of time prior to the first scheduled replacement point for that part. If the part fails prior to the first scheduled replacement, the part shall be repaired or replaced by Sears, Roebuck and Co. according to Subsection 4 below. Any such emissions-related part repaired or replaced under the ECS Warranty, shall be warranted for the remainder of the ECS Warranty Period prior to the first scheduled replacement point for such emissions-related part.

4. Repair or replacement of any warranted, emissions-related part under this ECS Warranty shall be performed at no charge to the owner at a Sears, Roebuck and Co. Authorized Service Outlet.

5. The owner shall not be charged for diagnostic labor which leads to the determination that a part covered by the ECS Warranty is in fact defective, provided that such diagnostic work is performed at a Sears, Roebuck and Co. Authorized Service Outlet.

6. Sears, Roebuck and Co. shall be liable for damages to other original engine components or approved modifications proximately caused by a failure under warranty of an emission-related part covered by the ECS Warranty.

7. Throughout the ECS Warranty Period, Sears, Roebuck and Co. shall maintain a supply of warranted emission-related parts sufficient to meet the expected demand for such emission-related parts.

8. Any Sears, Roebuck and Co. authorized and approved emission-related replacement part may be used in the performance of any ECS Warranty maintenance or repair and will be provided without charge to the owner. Such use shall not reduce Sears, Roebuck and Co. ECS Warranty obligations.

9. Unapproved add-on or modified parts may not be used to modify or repair a Sears, Roebuck and Co. engine. Such use voids this ECS Warranty and shall be sufficient grounds for disallowing an ECS Warranty claim. Sears, Roebuck and Co. shall not be liable hereunder for failures of any warranted parts of a Sears, Roebuck and Co. engine caused by the use of such an unapproved add-on or modified part.

EMISSION-RELATED PARTS INCLUDE THE FOLLOWING:

1. Carburetor Assembly and its Internal Components
 - a) Fuel filter
 - b) Carburetor gaskets
 - c) Intake pipe
2. Air Cleaner Assembly
 - a) Air filter element
3. Ignition System, including:
 - a) Spark plug
 - b) Ignition module
 - c) Flywheel assembly
4. Catalytic Muffler (if so equipped)
 - a) Muffler gasket (if so equipped)
 - b) Exhaust manifold (if so equipped)
5. Crankcase Breather Assembly and its Components
 - a) Breather connection tube

10/22/99 EPA/CARB

Sears, Roebuck and Co., Hoffman Estates, IL 60179 U.S.A.



SLOPE GUIDE

Fold this page along dotted line indicated below. Hold page before you so that its left edge is vertically parallel to a tree trunk or other upright structure. Sight across the fold in the direction of the hill or slope you want to measure. Compare the angle of the fold with the slope of the hill.

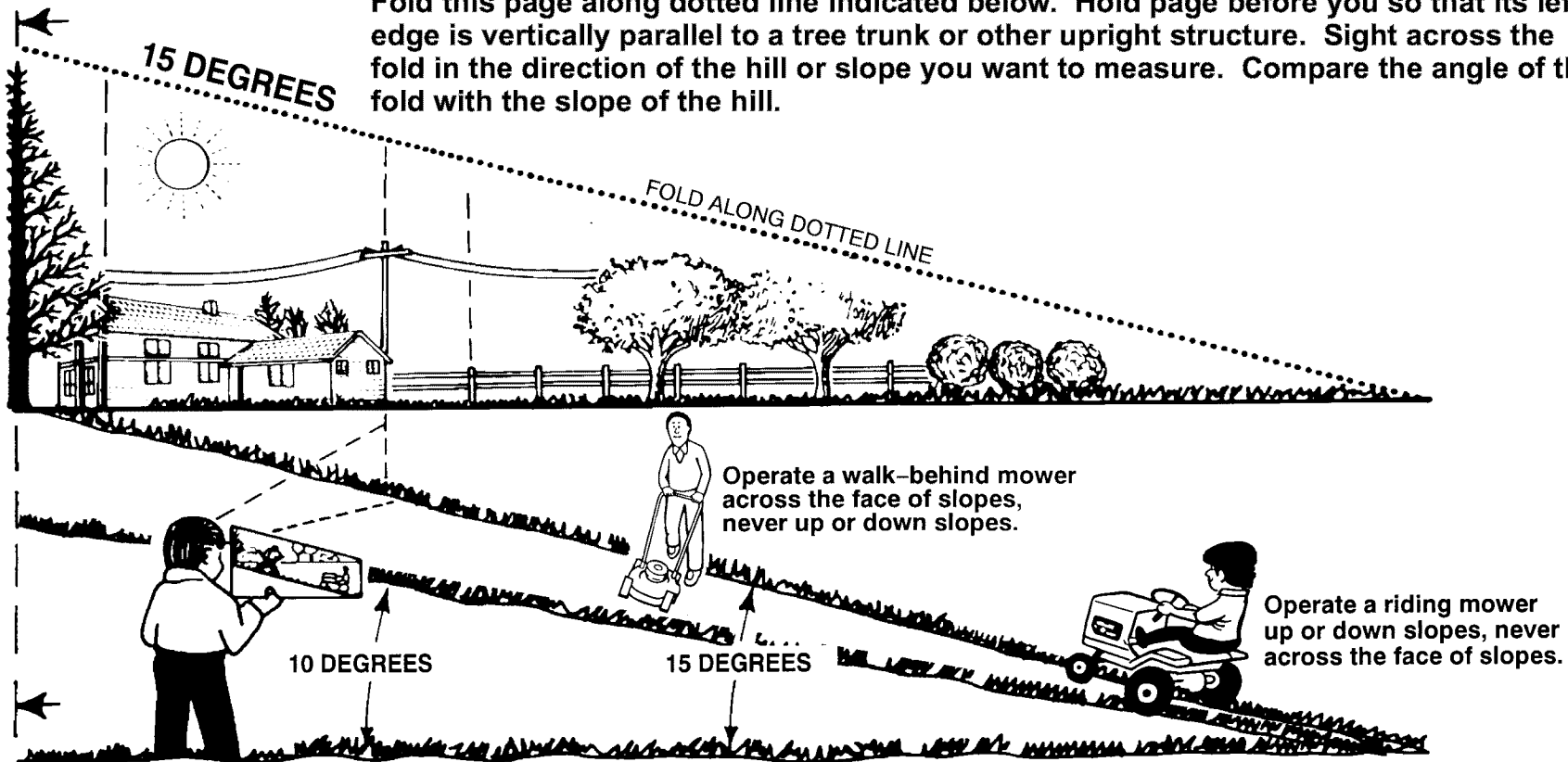

On a riding mower to determine if a slope is safe to mow: (1) disengage the blade(s), (2) put the unit in reverse, and (3) try to back straight up the slope. If you can back up the slope, it is generally safe to mow. However, if you do not feel safe, or you are not completely sure, use this guide to determine the slope angle.



WARNING: To avoid possible serious injury, do not mow a slope that is greater than 15 degrees. If the riding mower is used with a pull-behind or rear-mounted attachment, do not operate the unit on a slope that is greater than 10 degrees.

CUT HERE TO USE SLOPE GUIDE

MODEL 536.270270

REPAIR PARTS CHASSIS & HOOD

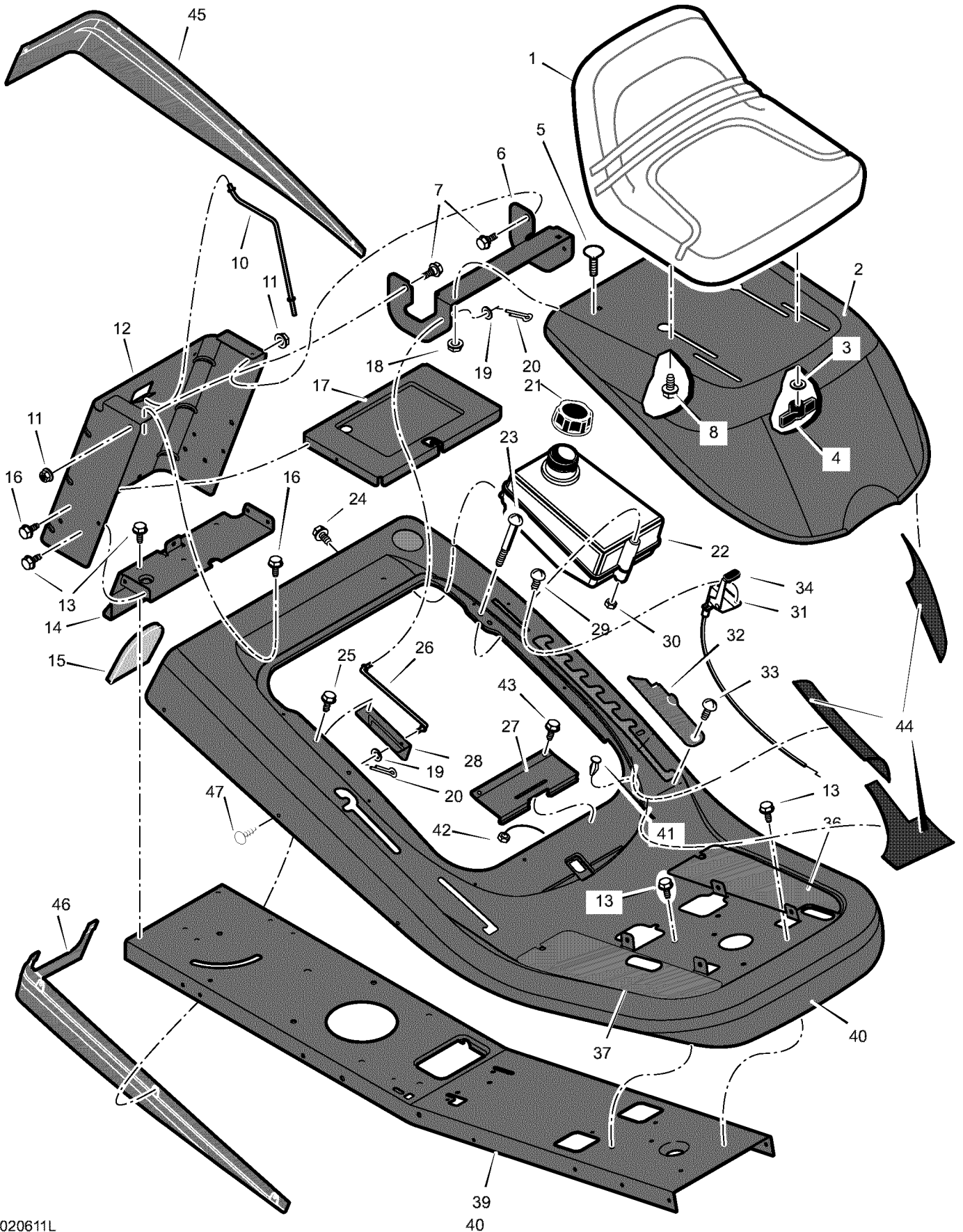

MODEL 536.270270

REPAIR PARTS CHASSIS & HOOD

Key No.	Part No.	Description	Key No.	Part No.	Description
1	690566	Seat	24	26x253	Screw
2	1401027E549	Hood	25	26x263	Screw
3	017x47	Washer	26	1401110	Rod, Hood Prop
4	1001054	Bolt, Wing	27	1401041	Spring, Seat Deck
5	002x53	Bolt, Carriage	28	1401056E701	Bracket, Prop Rod
6	1401036E701	Bracket, Hinge	29	26x201	Screw
7	009x29	Bolt, Shoulder	30	15x116	Nut, NY-Lock
8	009x56	Bolt, Shoulder	31	1401169	Control, Throttle
10	1401113	Rod, Battery	32	1401084	Cover, Detent (Black)
11	015x84	Nut, Flange	33	009x47	Bolt, Shoulder
12	1401025E701	Plate, Rear	36	1401145	Footmat, Left (Black)
13	26x249	Screw	37	1401192	Footmat, Right (Black)
14	1401050E701	Plate, Hitch	39	1401256E701	Frame
15	1401087	Cover	40	1401085E549	Deck, Seat
16	26x263	Screw	41	094744	Bumper
17	1401076E701	Tray, Battery	42	15x116	Nut *
18	015x79	Nut, Flange	43	0025x2	Screw
19	017x37	Washer	44	7601036	Kit, Foil Heat Shield
20	0031x6	Pin, Cotter	45	1401073	Trim, Left
21	092317	Cap, Fuel Tank *	46	1401072	Trim, Right
22	7601040	Tank, Fuel	47	0193x1	Fastener, Panel
23	06x111	Screw *	--	F-020611L	Book, Instruction

* These parts are included when ordering Key number 22.

MODEL 536.270270

REPAIR PARTS STEERING

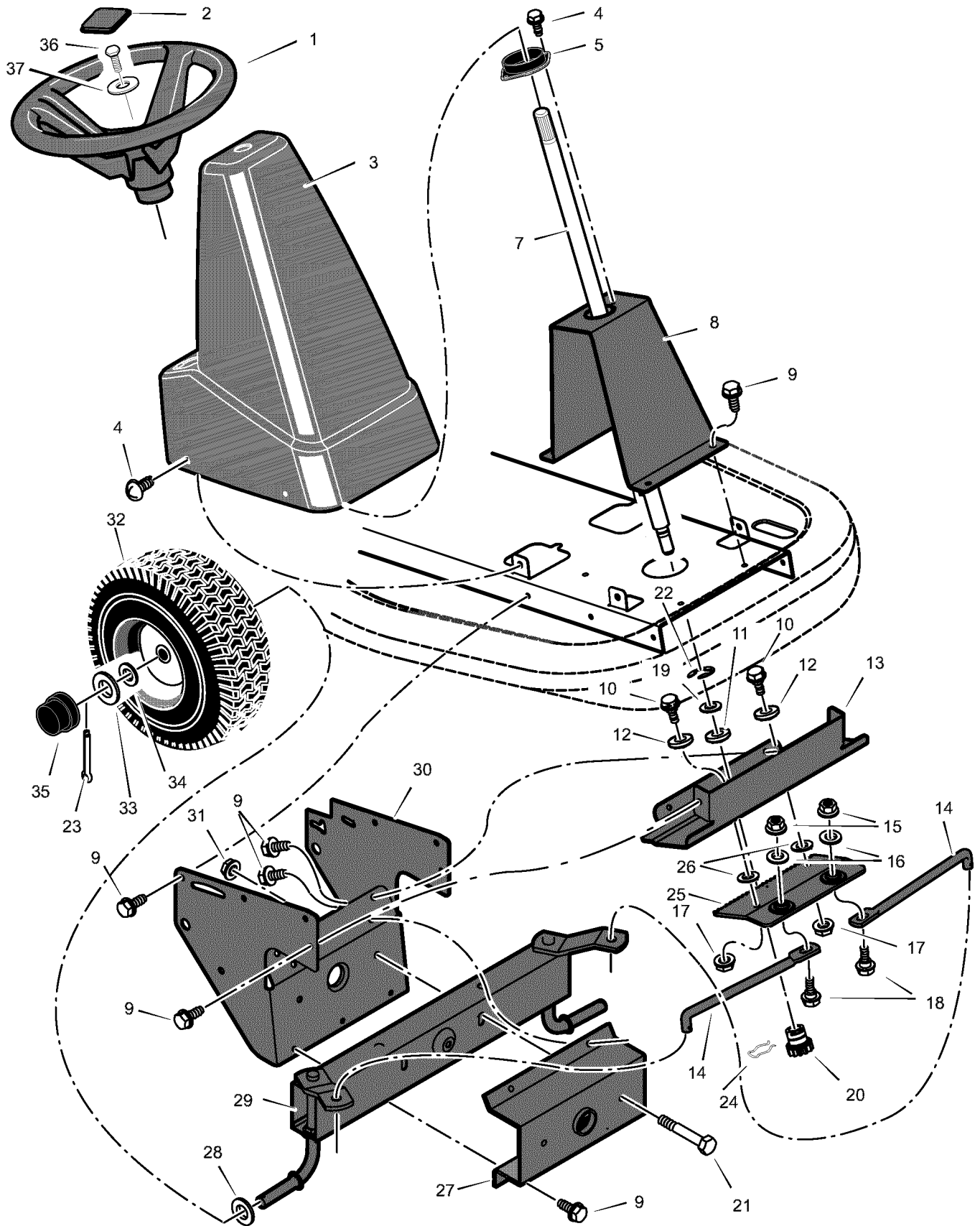

MODEL 536.270270

REPAIR PARTS STEERING

Key No.	Part No.	Description	Key No.	Part No.	Description
1	095185	Wheel, Steering	20	1401099	Gear, Pinion
2	0711326	Cap, Steering (Black)	21	01x146	Bolt, Hex
3	1401067	Console, High (Black)	22	011x28	E-Ring, Retainer
4	26x270	Screw	23	030x35	Pin, Cotter
5	1401090	Bearing, Upper Steering	24	094131	Retainer, Spring
7	1401100	Shaft, Steering	25	1401046E701	Rack, Steering
8	1401055E701	Support, Steering	26	17x102	Washer
9	26x249	Screw	27	1401060E701	Bracket, Axle Front
10	009x67	Bolt, Shoulder	28	17x157	Washer
11	1401098	Bearing, Lower Steering	29	1401126E701	Axle & Spindle Assembly
12	1401102	Roller	30	1401059E701	Bracket, Support
13	1401058E701	Plate, Gear Mounting	31	15x118	Nut, Flange
14	1401123E701	Link, Drag	32	1401143	Wheel, Front
15	015x84	Nut, Flange	33	17x197	Washer
16	17x104	Washer	34	17x157	Washer
17	015x88	Nut, Flange	35	094618	Cap, Hub
18	01x111	Bolt, Hex	36	0025x3	Bolt
19	17x118	Washer	37	17x146	Washer

* When you order a tire, make sure to give the brand name of the tire so that the tread pattern on the tire will match.

MODEL 536.270270

REPAIR PARTS MOTION DRIVE

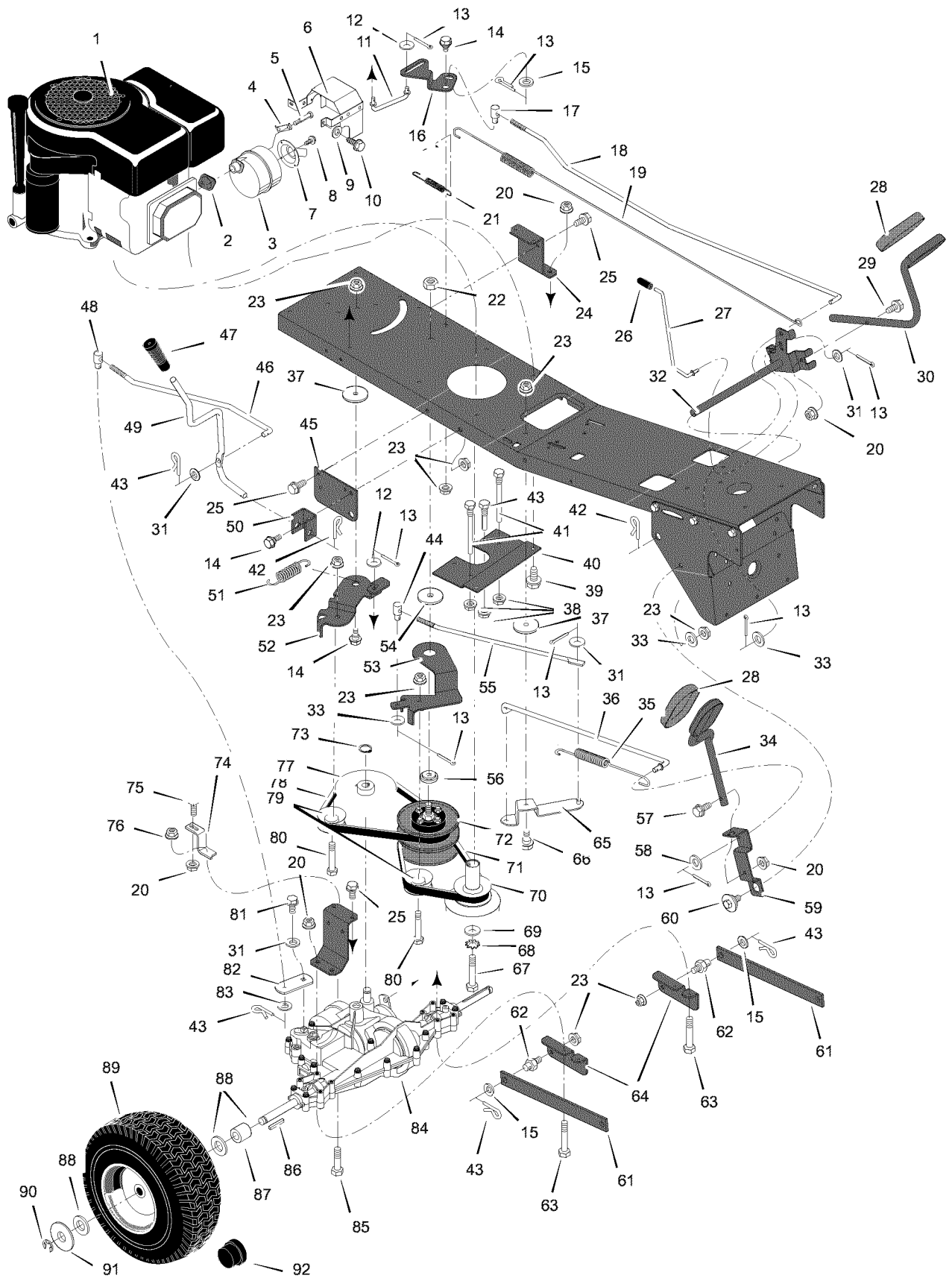

MODEL 536.270270

REPAIR PARTS MOTION DRIVE

Key No.	Part No.	Description	Key No.	Part No.	Description
1	-----	Engine	48	1401148	Nut, Adjusting
2	091309	Gasket, Muffler	49	1401111	Lever, Shift
3	091271	Muffler	50	1401043E701	Bracket, Pivot
4	092378	Lock, Muffler Screw	51	165x156	Spring, Variator Drive
5	01x134	Bolt, Hex	52	1401131 Z	Arm, Idler
6	1401207	Shield, Heat	53	1401132 Z	Arm, Clutch Ider
7	1401204	Tube, Exhaust	54	17x210 HT	Washer
8	26x208	Screw	55	1401136	Link, Drive
9	018x32	Washer, Lock	56	1401124	Spacer
10	0025x2	Screw	57	01x139	Bolt
11	1401170	Rod, Link	58	017x53	Washer
12	017x45	Washer	59	1401164E701	Arm, Pedal
13	030x20	Pin, Cotter	60	009x69	Bolt, Shoulder
14	009x39	Bolt, Shoulder	61	1401031E701	Arm, Rear
15	17x102	Washer	62	094067	Pin, Threaded
16	1401166	Link, Clutch	63	01x155	Bolt, Hex
17	092132	Nut, Adjusting	64	1401039E701	Bracket, Rear Hanger
18	1401165	Rod, Clutch Variator	65	1401183E701	Link Assembly, Pivot
19	165x148	Spring, Brake	66	009x15	Bolt, Shoulder
20	015x88	Nut	67	01x140	Bolt, Hex
21	165x75	SprinG, Brake Return	68	019x35	Lockwasher
22	15x137	Nut	69	17x170	Washer
23	015x84	Nut	70	1401158	Pulley Stack
24	1401042E701	Bracket, Transaxle –Left	71	37x114	Belt, Primary Drive
25	26x249	Screw	72	1401035	Pulley Assembly, Variator
26	091079	Grip	73	0011x7	Ring, Snap
27	1401112	Rod, Parking Brake	74	1401051E701	Bracket, Torque Reactor
28	1401139	Pad, Pedal	75	002x53	Bolt, Carriage
29	01x139	Bolt, Hex	76	015x43	Nut, Stoverlock
30	1401179E701	Rod, Clutch/Brake	77	1401157	Pulley, Transaxle
31	017x38	Washer	78	37x115	Belt, Secondary Drive
32	1401180E701	Rod, Clutch/Brake Pivot	79	1401156	Pulley, Idler
33	017x53	Washer	80	01x111	Bolt, Hex
34	1401181E701	Pedal, Variator	81	06x105	Cap Screw
35	165x158	Spring, Return	82	1401093	Yoke, Shift
36	1401142	Rod, Variator Connect	83	17x148	Washer
37	17x174 HT	Washer	84	-----	Transaxle
38	015x79	Nut	85	01x120	Bolt, Hex
39	025x7	Screw	86	056534	Key, Square
40	1401057E701	Plate, Belt Guide	87	1401103	Spacer, Rear Wheel
41	1401105	Guide, Belt –Long	88	17x160	Washer
42	031x4	Pin, Hair	89	1401120	Wheel & Tire Assembly
43	1401104	Guide, Belt –Short	--		Tire (ONLY)
44	021920	Nut, Adjusting	--		Tube (ONLY)
45	1401032E701	Bracket, Lift Pivot	90	0011x3	E–Ring
46	1401122	Rod, Shift Link	91	17x195	Washer
47	092697	Grip	92	094618	Hub Cap



MODEL 536.270270

REPAIR PARTS MOWER HOUSING SUSPENSION

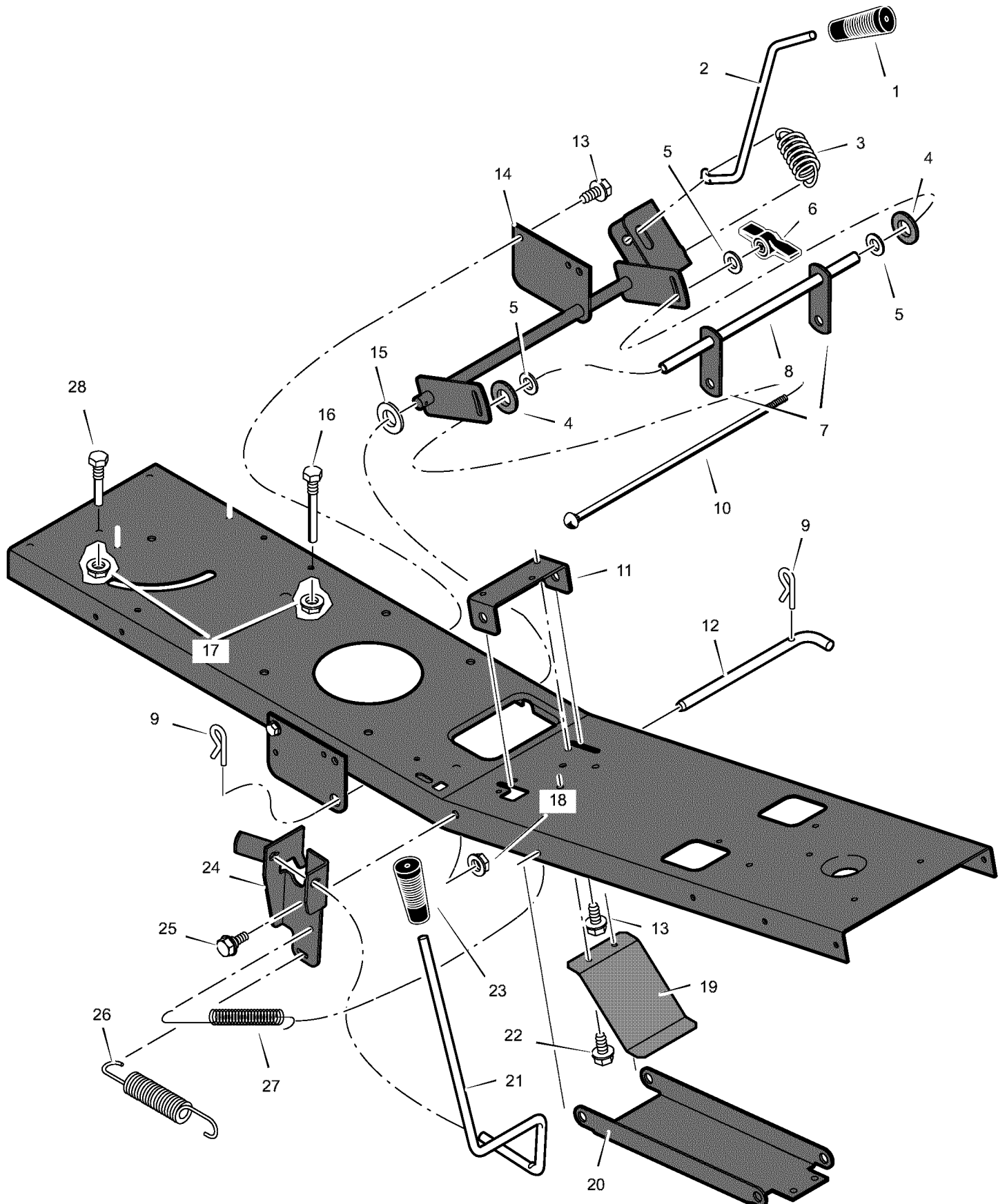

MODEL 536.270270

REPAIR PARTS MOWER HOUSING SUSPENSION

Key No.	Part No.	Description	Key No.	Part No.	Description
1	092697	Grip, Lift Lever	15	17x165	Washer
2	1401117	Lever, Lift	16	091754	Screw, Guide
3	165x154	Spring, Extension	17	015x79	Nut, Flange
4	094137	Pad, Friction	18	015x84	Nut, Flange
5	017x45	Washer	19	1401147	Spring, Leaf
6	095004	Wingnut	20	1401040E701	Hanger, Front
7	1401033E701	Link, Lift	21	1401116	Lever, PTO
8	1401096	Tube, Spacer	22	26x263	Screw
9	0031x4	Pin, Hair	23	094198	Grip, PTO
10	002x93	Bolt, Carriage	24	1401199E701	Bracket, PTO
11	1401030E701	Bracket, Front Hanger Pivot	25	009x39	Bolt, Shoulder
12	1401118	Pin, Front Hanger	26	165x157	Spring, Extension
13	26x249	Screw	27	165x92	Spring, Extension
14	1401262E701	Arm Assembly, Lifter	28	020619	Screw, Guide

MODEL 536.270270

REPAIR PARTS MOWER HOUSING

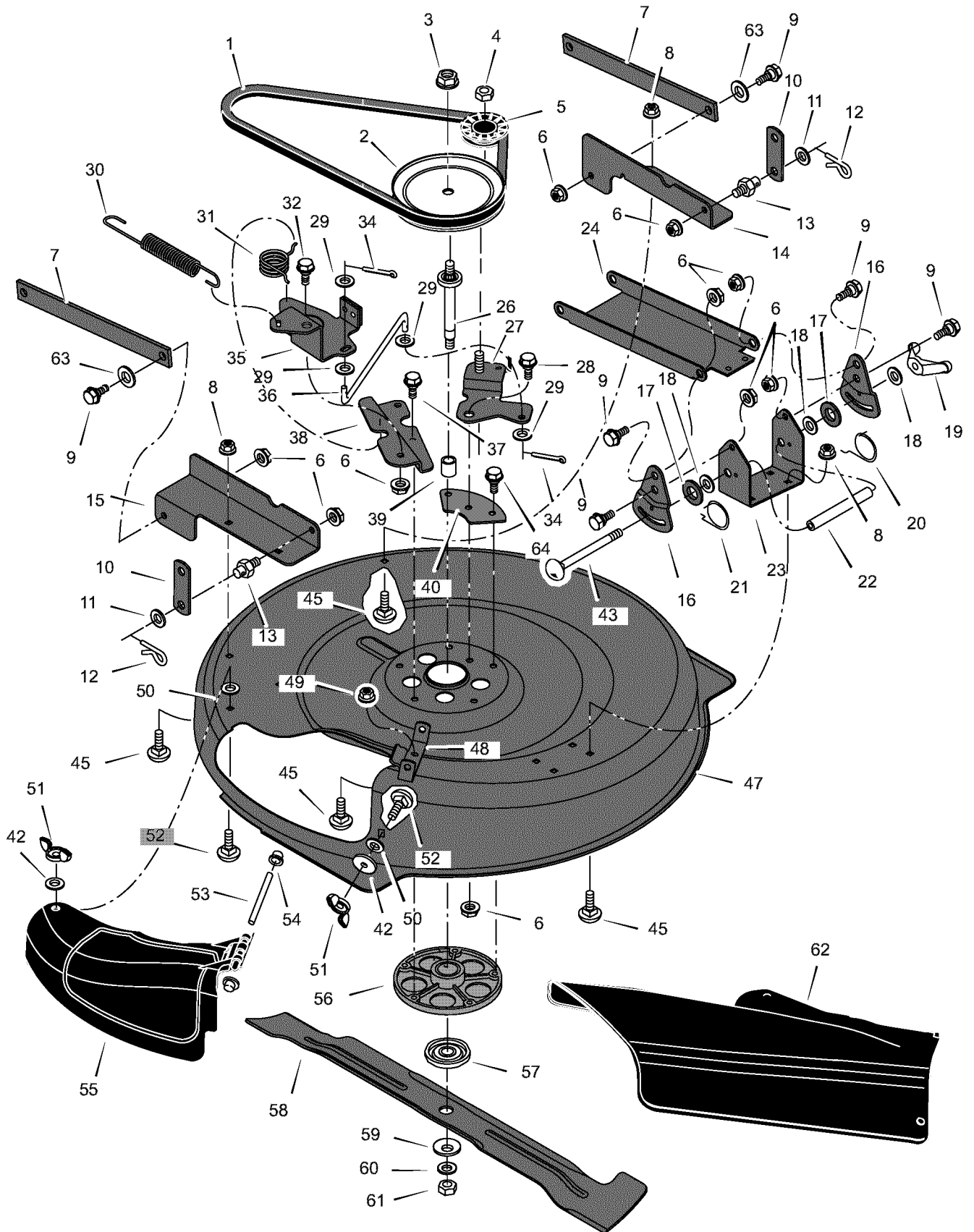

MODEL 536.270270

REPAIR PARTS MOWER HOUSING

Key No.	Part No.	Description	Key No.	Part No.	Description
1	37x111	Belt, Blade Drive	32	009x42	Bolt, Shoulder
2	1401092	Pulley, Input	34	030x20	Pin, Cotter
3	15x121	Locknut	35	1401185E701	Arm Assembly, Brake
4	015x98	Nut, Flange	36	1401119	Link, Idler Arm
5	1401252	Pulley, Idler	37	0025x7	Bolt
6	015x84	Nut, Flange	38	1401052E701	Bracket, Brake Mounting
7	1401031E701	Arm, Rear	39	1401094	Spacer, Jackshaft
8	015x79	Nut, Flange	40	1401259 Z	Plate, Idler Mounting
9	009x58	Bolt, Shoulder	42	019x45	Washer
10	1401033E701	Link, Lift	43	002x94	Bolt, Carriage
11	17x102	Washer	45	002x53	Bolt, Carriage
12	0031x4	Pin, Hair	47	1401028E701	Housing, Blade
13	094067	Pin, Threaded Shoulder	48	1401106E701	Hinge, Mulching Cover
14	1401047E701	Bracket, Left Rear	49	015x88	Nut, Flange
15	1401235E701	Bracket, Right Rear	50	028x76	Nut, Speed
16	1401038E701	Plate, Adjustment	51	014x86	Wingnut
17	094137	Pad, Friction	52	002x74	Bolt, Carriage
18	017x45	Washer	53	091767 Z	Rod, Chute Deflector
19	095004	Wingnut	54	028x23	Cap, Push
20	166x43	Spring, Left Torsion	55	1401080	Cover, Mulch
21	166x42	Spring, Right Torsion	56	094305	Mandrel Housing
22	1401095	Tube, Spacer	57	1001035	Adapter, Blade
23	1401037E701	Bracket, Deck	58	1401079E701	Blade
24	1401040E701	Hanger, Front	59	17x166	Washer, Cup
26	1401065	Shaft, Splined	60	17x165	Washer
27	1401258E701	Arm Assembly , Idler	61	15x100	Nut, Blade Mount
28	009x39	Bolt, Shoulder	62	1401081	Deflector, Chute
29	017x47	Washer	63	002x74	Bolt, Carriage
30	165x157	Spring, Extension	64	001x84	Bolt
31	166x46	Spring, Torsion			

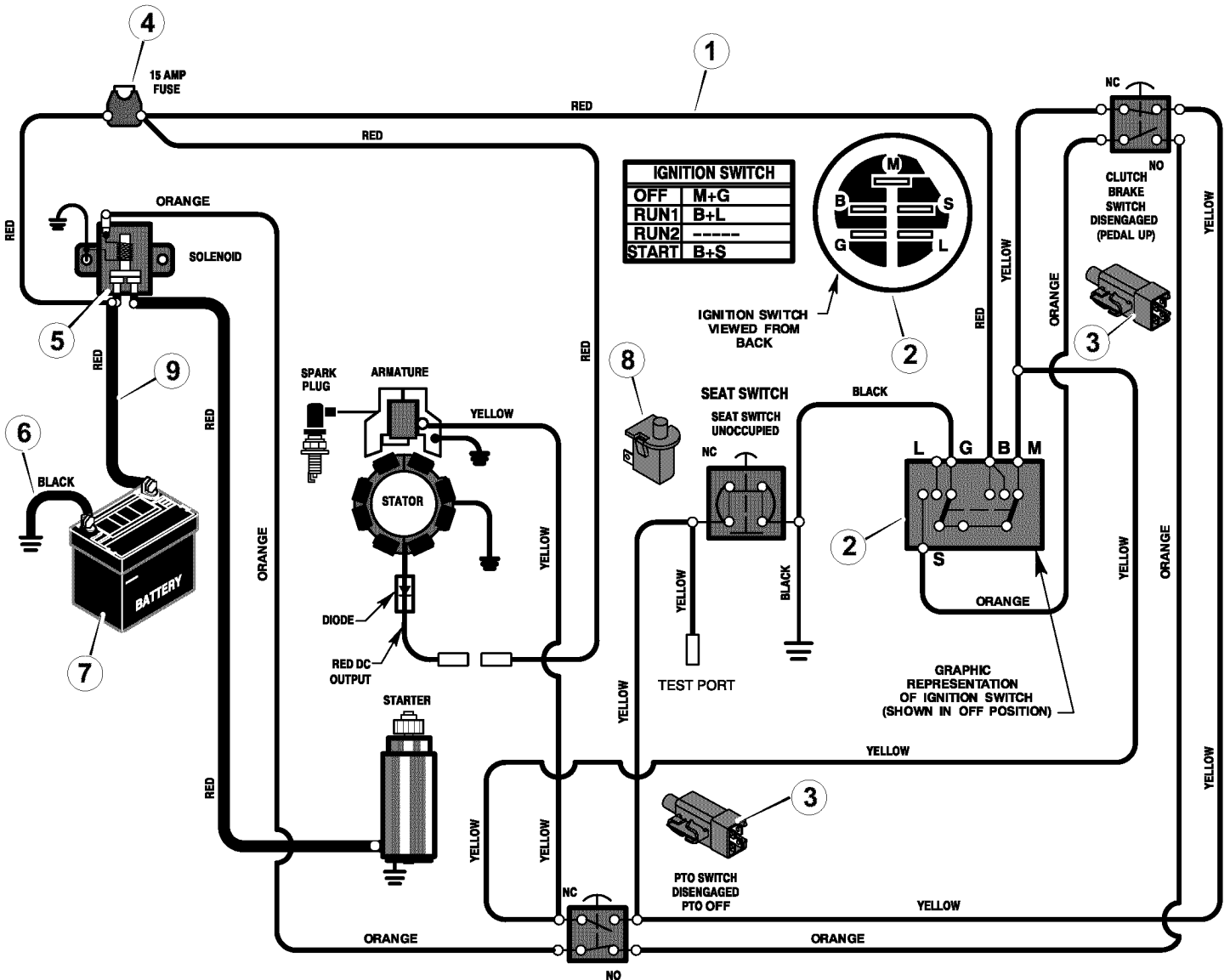

MODEL 536.270270

REPAIR PARTS ELECTRICAL SYSTEM

Key No.	Part No.	Description
1	250x102	Harness, Chassis Wire
2	1401149	Switch, Ignition
	327349	Key, Ignition
		Nut, Hex
		Cap, Ignition
3	094136	Switch, Limit
4	054212	Fuse
	407078	Holder, Fuse
5	094613	Solenoid
	26x229	Screw, Mounting
	15x116	Locknut
6	024x37	Cable, Battery Ground
		Screw, Ground Cable
7	092739	Battery
	002x82	Bolt, Carriage
	014x79	Wingnut
8	094159	Switch, Seat Sensor
9	024x24	Cable, Red Batery
	690604	Boot, Positive Terminal



MODEL 536.270270

REPAIR PARTS DECALS

Key No.	Part No.	Description (Location)	Qty.
--	48x729	Gas Gage (Dash –Left Side)	1
--	44x7197	DEKA (Battery)	1
--	44x7325	Warning (Seat Deck –Middle)	1
--	48x928	1–5 Height Adjust (Seat Deck –Left Side)	1
--	48x746	NO STEP (Mower Deck – Left Side)	1
--	48x929	Clutch / Brake (Footrest –Left Side)	1
--	48x236	Cut Finger (Mower Deck –Right Side)	1
--	48x1192	Craftsman Variator 13.5 (Hood –Right Side)	1
--	48x1191	Craftsman Variator 13.5 (Hood –Left Side)	1
--	44x6456	Deck Level Position / ONLY (Seat Deck –Left Side)	1
--	48x741	Drive 1 (Seat Deck –Right Side)	1
--	44x7535	Cutting Height (Seat Deck –Left Side)	1
--	48x1189	Craftsman Logo (Seat Deck Front)	2
--	48x1190	Mow/Trim (Mower Deck – Right Side)	1
--	48x726	Parking Brake Symbol (Console)	1
--	48x728	Throttle Control (Console)	1
--	48x927	Blade Engage / Disengage (Seat Deck –Right Side)	1



NOTES

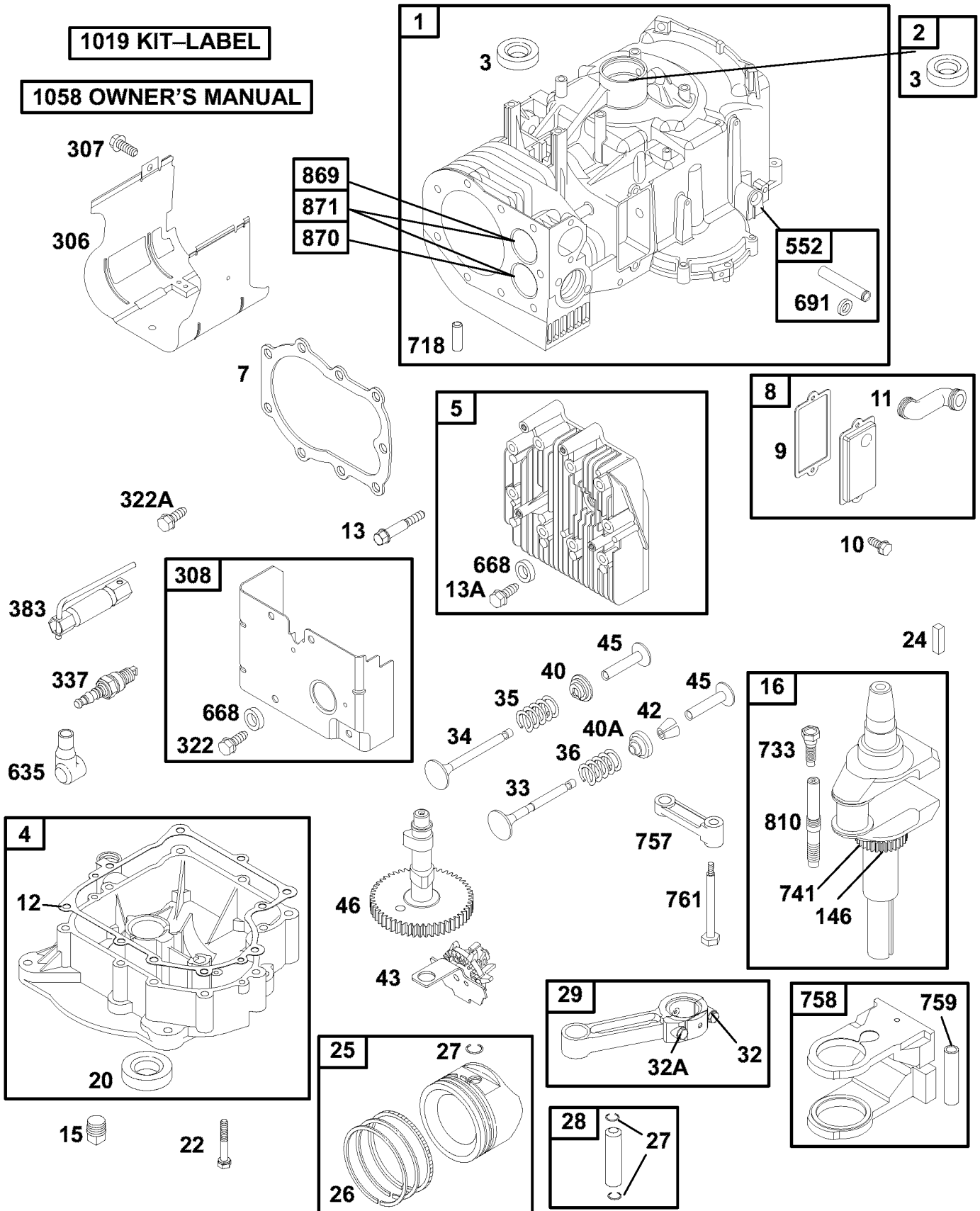

MODEL 536.270270

B&S ENGINE 28R707-1114-E1

REF. NO.	PART NO.	DESCRIPTION	REF. NO.	PART NO.	DESCRIPTION	REF. NO.	PART NO.	DESCRIPTION	
1	496413	Cylinder Assembly		696400	Piston Assembly (.030" Oversize)	146	691639	Key-Timing	
2	399265	Kit-Bushing/Seal (Magneto Side)	26	696403	Ring Set (Standard)	306	690459	Shield-Cylinder	
3	★391086	Seal-Oil (Magneto Side)			————— Note —————	307	691003	Screw (Cylinder Shield)	
4	494238	Sump-Engine		696404	Ring Set (.010" Oversize)	308	491490	Cover-Cylinder Head	
5	494240	Head-Cylinder		696405	Ring Set (.020" Oversize)	322	692198	Screw (Cylinder Head Cover)	
7	∅★271866	Gasket-Cylinder Head		696406	Ring Set (.030" Oversize)	322A	691681	Screw (Cylinder Head Cover)	
8	495735	Breather Assembly	27	691299	Lock-Piston Pin	337	802592	Spark Plug	
9	∅★27803	Gasket-Breather	28	498319	Pin-Piston (Standard)	383	89838	Wrench-Spark Plug	
10	691666	Screw (Breather Assembly)			————— Note —————	552	491986	Bushing-Governor Crank	
11	691328	Tube-Breather		498320	Pin-Piston (.005" Undersized)	635	66538	Boot-Spark Plug	
12	★692226	Gasket-Crankcase (.015" Thick, Standard)	29	494504	Rod-Connecting (Standard)	668	690510	Spacer	
		————— Note —————			————— Note —————	691	★692407	Seal-Governor Shaft	
		★692406 Gasket-Crankcase (.005" Thick)		495490	Rod-Connecting (.020" Undersized)	718	690959	Pin-Locating	
		★692405 Gasket-Crankcase (.009" Thick)	32	690356	Screw (Connecting Rod)	733	691658	Screw (Crankshaft Extension)	
13	690904	Screw (Cylinder Head)	32A	690348	Screw (Connecting Rod)	741	691284	Gear-Timing	
13A	691681	Screw (Cylinder Head)		33	262246	Valve-Exhaust	757	691714	Link-Counterweight
15	690946	Plug-Oil Drain		34	262247	Valve-Intake	758	692423	Counterweight
16	693944	Crankshaft		35	691605	Spring-Valve (Intake)	759	691239	Pin-Counterweight
20	★291675	Seal-Oil (PTO Side)		36	691597	Spring-Valve (Exhaust)	761	691096	Screw (Counterweight)
22	692125	Screw (Engine Sump)		40	690656	Retainer-Valve (Intake)	810	691779	Extension-Crankshaft
24	222698	Key-Flywheel		40A	691939	Retainer-Valve (Exhaust)	869	691802	Seat-Valve (Intake)
25	696397	Piston Assembly (Standard)		42	494553	Keeper-Valve	870	691844	Seat-Valve (Exhaust)
		————— Note —————		43	691968	Slinger-Governor/Oil	871	261961	Bushing-Valve Guide (Exhaust Valve)
		696398 Piston Assembly (.010" Oversize)		45	691811	Tappet-Valve			————— Note —————
		696399 Piston Assembly (.020" Oversize)		46	692123	Camshaft			231218 Bushing-Valve Guide (Intake Valve, Brass)
							1019	491252	Kit-Label
							1058	274787	Owners Manual (Emission)



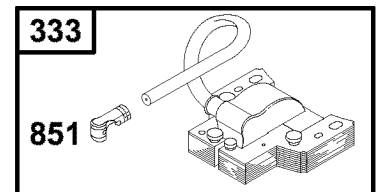
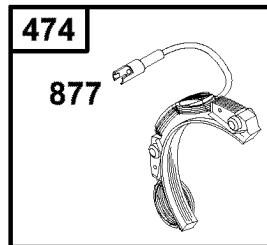
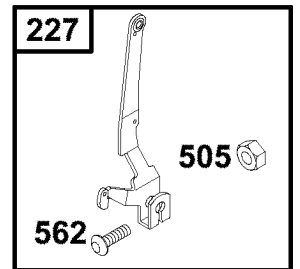
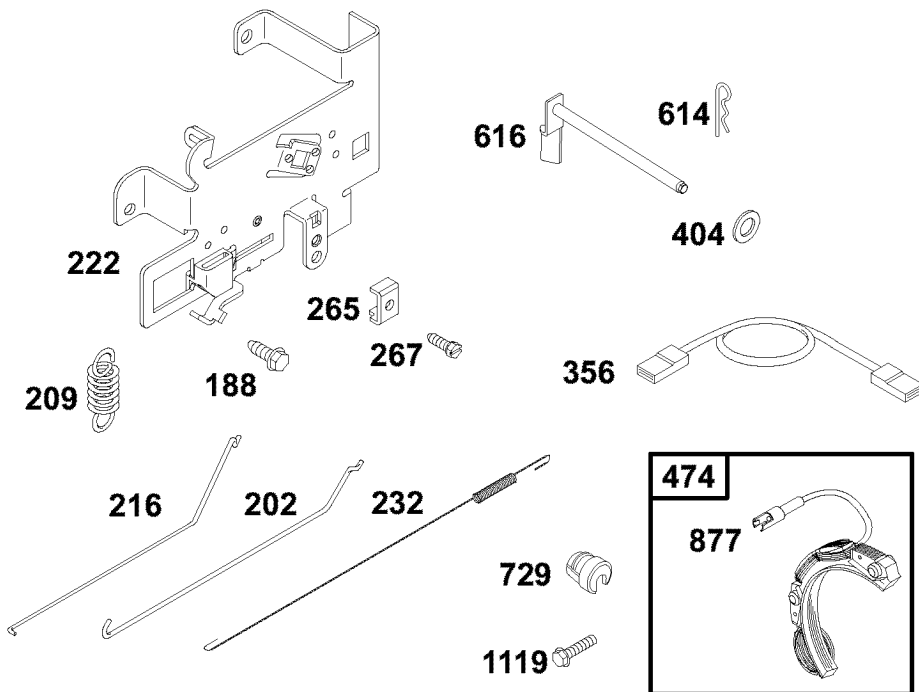
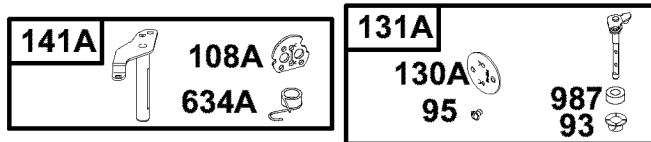
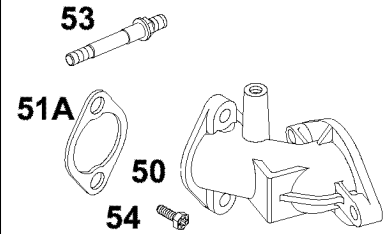
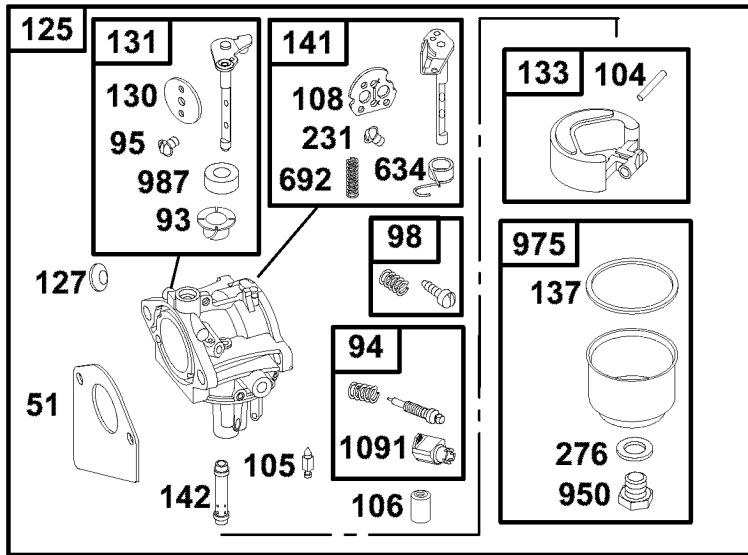

MODEL 536.270270

B&S ENGINE 28R707-1114-E1

REF. NO.	PART NO.	DESCRIPTION	REF. NO.	PART NO.	DESCRIPTION	REF. NO.	PART NO.	DESCRIPTION
50	691711	Manifold-Intake	133	494381	Float-Carburetor	404	691691	Washer
51	●692284	Gasket-Intake	137	●281165	Gasket-Float Bowl			(Governor Crank)
51A	★Ø272554	Gasket-Intake	141	495097	Kit-Choke Shaft	474	691953	Alternator
53	691098	Stud			(Manual Choke)	505	691251	Nut
		(Carburetor)	141A	495931	Kit-Choke Shaft			(Governor Control Lever)
54	690953	Screw			(Choke A Matic)	562	691119	Bolt
		(Intake Manifold)	142	●691434	Nozzle-Carburetor			(Governor Control Lever)
93	●690602	Bushing-Throttle Shaft	188	691693	Screw	614	691620	Pin-Cotter
94	498030	Kit-Idle Mixture			(Control Bracket)	616	692012	Crank-Governor
95	●691636	Screw	202	691841	Link-Mechanical	634	●690801	Spring/Seal Assembly
		(Throttle Valve)			Governor			(Manual Choke)
98	495800	Kit-Idle Speed	209	690480	Spring-Governor	634A	●690802	Spring/Seal Assembly
104	●690525	Pin-Float Hinge	216	691840	Link-Choke			(Choke A Matic)
105	●231855	Valve-Float Needle	222	694042	Bracket-Control	692	690572	Spring-Detent
106	●690577	Seat-Inlet	227	691374	Lever-Governor Control	729	690596	Clip-Wire
108	690464	Valve-Choke	231	●691636	Screw	851	493880	Terminal-Sparkplug
		(Manual Choke)			(Choke Valve)	877	393814	Wire/Connector-
108A	692344	Valve-Choke	232	691842	Spring-Governor Link			Alternator
		(Choke A Matic)	265	691024	Clamp-Casing	950	691657	Screw
125	498027	Carburetor	267	690804	Screw			(Float Bowl)
		(Walbro)			(Casing Clamp)	975	495933	Bowl-Float
127	694524	Plug-Welch	276	●692255	Washer-Sealing	987	●691326	Seal-Throttle Shaft
130	690468	Valve-Throttle	333	492341	Armature-Magneto	1091	691333	Cap-Limiter
130A	691750	Valve-Throttle	334	691061	Screw	1119	691183	Screw
131	494885	Kit-Throttle Shaft			(Magneto Armature)			(Alternator)
131A	494379	Kit-Throttle Shaft	356	690799	Wire-Stop			



MODEL 536.270270

B&S ENGINE 28R707-1114-E1

1036 LABEL-EMISSION

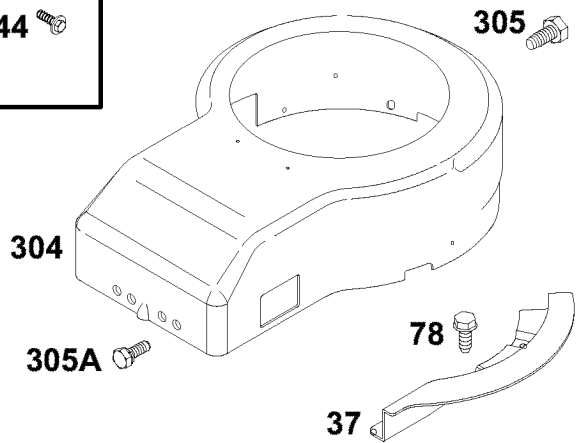
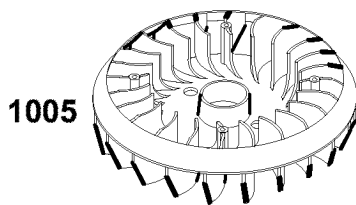
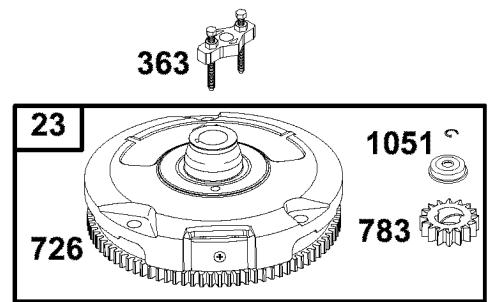
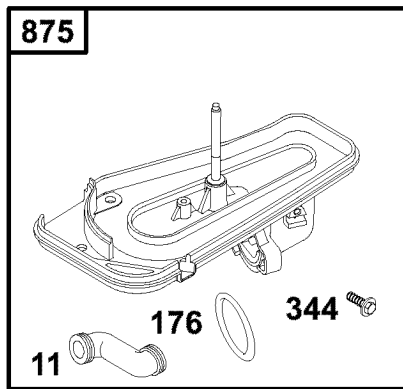
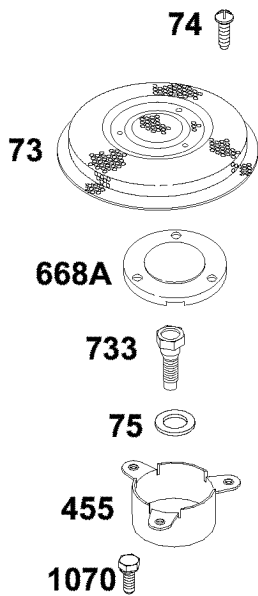
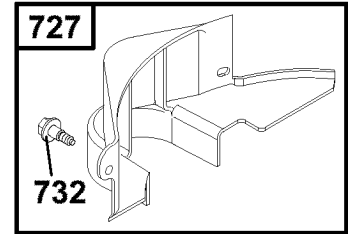
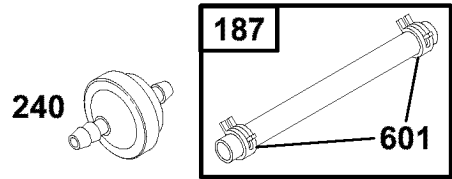
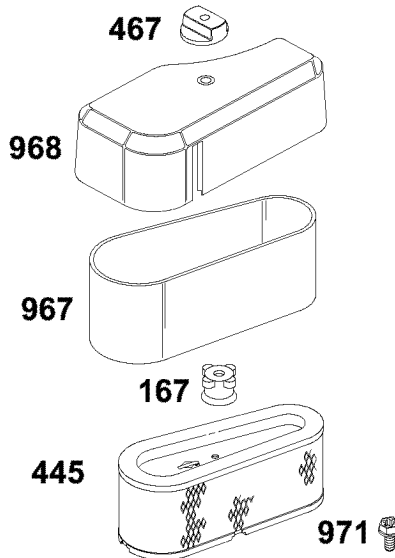
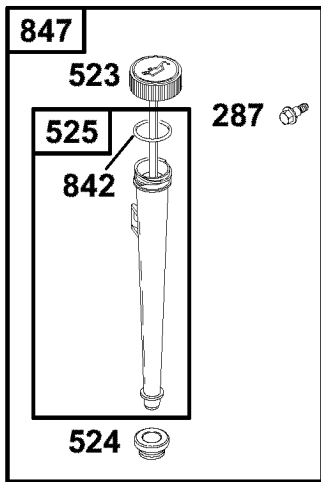

MODEL 536.270270

B&S ENGINE 28R707-1114-E1

REF. NO.	PART NO.	DESCRIPTION	REF. NO.	PART NO.	DESCRIPTION	REF. NO.	PART NO.	DESCRIPTION
11	691328	Tube—Breather	305	692198	Screw (Blower Housing)	732	691002	Screw (Starter Drive Cover)
23	693557	Flywheel	305A	692127	Screw (Blower Housing)	733	691658	Screw (Crankshaft Extension)
37	690456	Guard—Flywheel	363	19203	Flywheel Puller	783	693713	Gear—Pinion
73	690492	Screen—Rotating	445	496894	Filter—Air Cleaner Cartridge	842	★691870	Seal— O Ring (Dipstick/Tube Assembly)
74	691655	Screw (Rotating Screen)	455	691173	Cup—Flywheel	847	496415	Dipstick/Tube Assembly
75	690582	Washer (Flywheel)	467	691668	Knob—Air Cleaner	875	696129	Base—Air Cleaner
78	690661	Screw (Flywheel Guard)	523	692014	Dipstick	967	272403	Filter—Pre Cleaner
167	692297	Seal—Air Cleaner Nut	524	★281370	Seal—Dipstick Tube	968	691916	Cover—Air Cleaner
176	★691917	Seal—O Ring (Air Cleaner Base)	525	691398	Tube—Dipstick	971	692126	Screw (Air Cleaner Base)
185	690958	Nut (Air Cleaner Base)	601	95162	Clamp—Hose	1005	691905	Fan—Flywheel
187	691050	Line—Fuel (Cut to Required Length)	668A	691323	Spacer Gear—Ring (See Reference 23 for Service)	1036	695699	Label—Emission
240	298090	Filter—Fuel	726			1051	691265	Ring—Retaining
287	691002	Screw (Dipstick Tube)	727	490324	Cover—Starter Drive	1070	691058	Screw (Flywheel Fan)
304	690844	Housing—Blower						



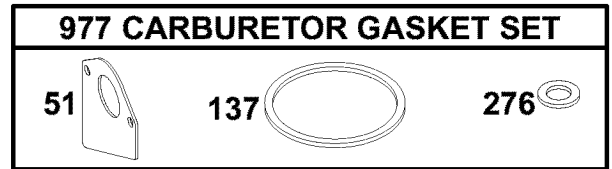
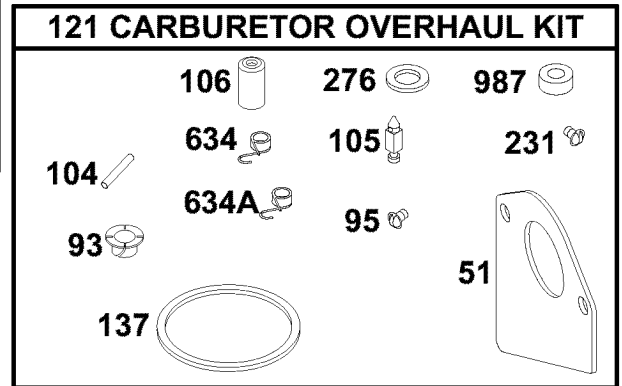
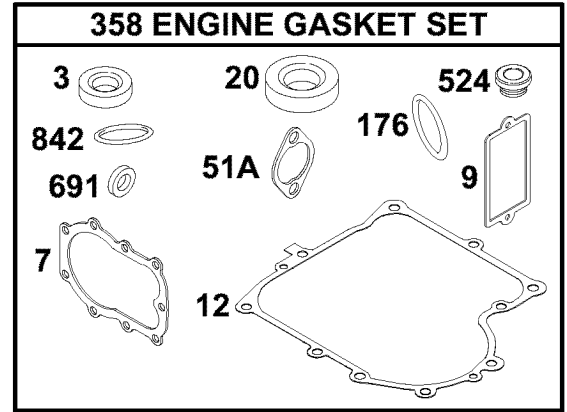
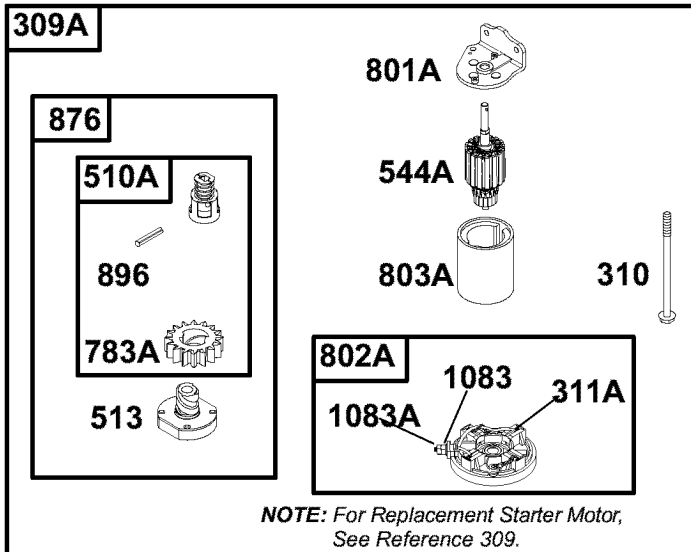
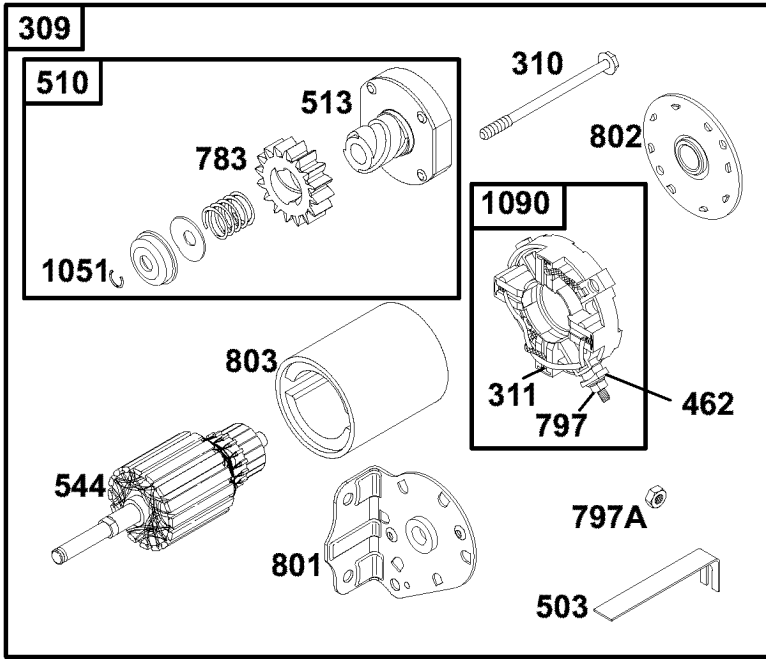

MODEL 536.270270

B&S ENGINE 28R707-1114-E1

REF. NO.	PART NO.	DESCRIPTION	REF. NO.	PART NO.	DESCRIPTION	REF. NO.	PART NO.	DESCRIPTION
3	★391086	Seal—Oil (Magneto Side)	276	●◆692255	Washer—Sealing			(Drive Cap)
7	∅★271866	Gasket—Cylinder Head	309	693551	Motor—Starter	729A	691224	Clip—Wire
9	∅★27803	Gasket—Breather	309A		Motor—Starter (For Replacement Starter Motor, See Ref. 309)	783	693713	Gear—Pinion
12	★692226	Gasket—Crankcase (.015" Thick, Standard)				783A	693059	Gear—Pinion
		Note	310	690323	Bolt (Starter Motor)	797	693167	Nut (Brush Retainer)
	★692406	Gasket—Crankcase (.005" Thick)	311	497608	Brush Set	797A	691029	Nut (Brush Retainer)
	★692405	Gasket—Crankcase (.009" Thick)	311A	395538	Brush Set	801	691429	Cap—Drive
20	★291675	Seal—Oil (PTO Side)	358	494241	Gasket Set—Engine	801A	394856	Cap—Drive
51	●◆692284	Gasket—Intake	462	691261	Washer (Brush Retainer)	802	691286	Cap—End
51A	★∅272554	Gasket—Intake	503	691532	Strap—Starter	802A	395537	Cap—End
93	●690602	Bushing—Throttle Shaft	510	693699	Drive—Starter	803	691427	Housing—Starter
95	●691636	Screw (Throttle Valve)	510A	495878	Drive—Starter	803A	398159	Housing—Starter
104	●690525	Pin—Float Hinge	513	692024	Clutch—Drive	842	★691870	Seal— O Ring (Dipstick Tube)
105	●231855	Valve—Float Needle	524	★281370	Seal—Dipstick Tube	876	495877	Kit—Pinion Spring
106	●690577	Seat—Inlet	544	692034	Armature—Starter	896	691641	Pin—Drive Retainer
121	499220	Kit—Carburetor Overhaul	544A	390837	Armature—Starter	977	494385	Gasket Set—Carburetor
137	●◆281165	Gasket—Float Bowl	634	●690801	Spring/Seal Assembly (Manual Choke)	987	●691326	Seal—Throttle Shaft
176	∅★691917	Seal—O Ring (Air Cleaner Base)	634A	●690802	Spring/Seal Assembly (Choke A Matic)	1051	691265	Ring—Retaining
			691	★692407	Seal—Governor Shaft	1083	691626	Nut (Starter Terminal)
231	●691636	Screw (Choke Valve)				1083A	690958	Nut (Starter Terminal)
			697	690372	Screw	1090	691293	Retainer—Brush
						1095	498539	Gasket Set—Valve



MODEL 536.270270

PEERLESS TRANSAXLE 915-033

Key No.	Part No.	Description	Key No.	Part No.	Description
1	772117	Transaxle Cover	40	792076A	Flat Washer .312 ID x .059W
2	780086A	Needle Bearing .625 ID	41	790045	Brake Lever
3	770110	Transaxle Case	42	792073A	Screw 1/4-20 x 1-1/4"
4	776300	Countershaft	43	792075	Locknut 5/16-24
6	778281	Spur Gear (16 teeth)	44	790025	Brake Pad Holder
7	778122A	Spur Gear (22 teeth)	46	786086	Brake Lever Bracket
8	792160	Shift Key	47	774665	Axle (12.00")
10	784365	Shift Rod & Fork	47B	774922	Axle (16-3/16" Long)
11A	778290A	Bevel Gear & Bearing (Incl. 174)	48B	774923	Axle (11.00")
12	778262	Bevel Pinion (14 teeth)	49	778250	Spur Gear (27 teeth)
13	778368	Bevel Gear (13 teeth) (Incl.14)	50	778151	Spur Gear (15 teeth)
14	778368	Bevel Gear (13 teeth) (Incl.13)	51	778273	Spur Gear (19 teeth-steel)
15	778360	Ring Gear (43 teeth)	54	778263	Spur Gear (11 teeth)
16	786150	Bearing Strip	56	778193	Spur Gear (15 teeth)
17	786139	Drive Pin	56	778249	Spur Gear (23 teeth)
18	786147	Neutral Sleeve Spacer .453L	57	778184	Spur Gear (20 teeth-steel)
20	792139	Steel Ball 3/8" DIA	57	778125	Spur Gear (35 teeth)
22	792142	Spring	58	778129A	Spur Gear (30 teeth)
23	788061	Seal Ring	61	778265	Spur Gear (34 teeth)
25	792073A	Screw 1/4-20 x 1-1/4"	63	786158	Spacer .765 x .937
26	792125	Retaining Ring	65A	780160	Thrust Washer .563 ID x .031W
27	792035	Retaining Ring	65	780162	Thrust Washer .703 ID x .091W
28	788040	Retaining Ring	66	776299	Input Shaft
29	780072	Thrust Washer .627 ID x .031W	67	776352	Shifter & Brake Shaft
30	780108	Cup Washer 1.127 ID x .032W	69	780161	Thrust Washer .703 ID x .031W
30A	780145	Flat Washer 1.127 ID x .032W	71	788069	Square Cut Ring
31	780001	Flat Washer .750 ID x .56W	76	780090	Flat Washer 1.128 ID x .058W
32	792001	"O" Ring .607 ID	77	788078	Retainer Ring
33	788076	"O" Ring .530 ID	79	792144	Spring
36	790071	Brake Disk	90	788067B	Grease (32 oz. bottle)
37	790007	Brake Pad Plate	150	510334	Gasket Eliminator (Locite #515)
38	799021	Brake Pad (pkg of 2)	161	776302	Reverse Idler
39	786026	Dowel Pin 5/16" x 3/4"	174	780085	Needle Bearing .625 ID

NOTES

Get it fixed, at your home or ours!

Your Home

For repair – **in your home** – of **all** major brand appliances, lawn and garden equipment, or heating and cooling systems, **no matter who made it, no matter who sold it!**

For the replacement parts, accessories and owner's manuals that you need to do-it-yourself.

For Sears professional installation of home appliances and items like garage door openers and water heaters.

1-800-4-MY-HOME® (1-800-469-4663)

Call anytime, day or night (U.S.A. and Canada)

www.sears.com www.sears.ca

Our Home

For repair of carry-in items like vacuums, lawn equipment, and electronics, call or go on-line for the location of your nearest

Sears Parts & Repair Center.

1-800-488-1222

Call anytime, day or night (U.S.A. only)

www.sears.com

To purchase a protection agreement on a product serviced by Sears:

1-800-827-6655 (U.S.A.)

1-800-361-6665 (Canada)

Para pedir servicio de reparación a domicilio, y para ordenar piezas:

1-888-SU-HOGARSM

(1-888-784-6427)

Au Canada pour service en français:

1-800-LE-FOYER^{MC}

(1-800-533-6937)

www.sears.ca

SEARS