

# Owner's Manual

## Conley

### 10' x 10' Gazebo with Awning and Bar

Model Number: CON-1010-21

SKU Number: 272-1939



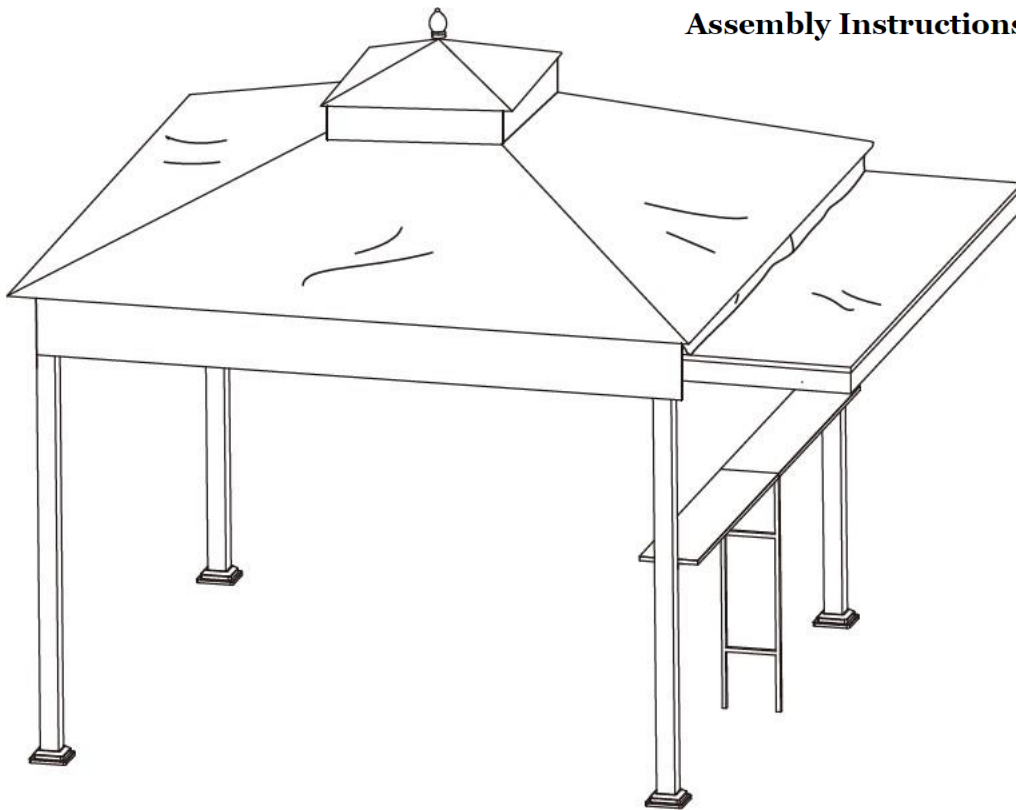



Scan For Video  
Assembly Instructions!



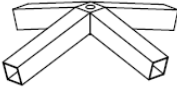
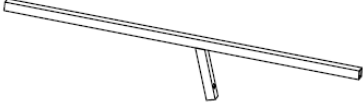



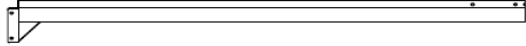

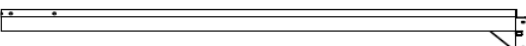

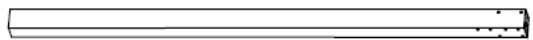

Note: This gazebo frame is designed to be used as a permanent fixture. Remove the main canopy and awning when not in use or during high winds, rain or snow.

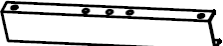

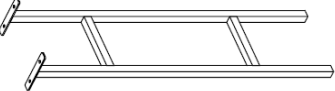
# Parts List

## 10' x 10' Gazebo with Awning and Bar

Letter	Illustration	Description	Qty.
A		Main Roof Connector	1
A1		Upper Roof Connector	1
A2		Upper Roof Support	4
A3		Finial	1
B		Main Roof Corner Support	4
B1		Main Roof Corner Support Extension	4
C		Main Roof Side Support	4
D		Cross Beam	3
D1		Cross Beam	3
D2		Cross Beam	1
D3		Cross Beam	1

Letter	Illustration	Description	Qty.
E		Corner Post	2
E1		Corner Post	1
E2		Corner Post	1
F		U-Shaped Connector	8
F1		Cross Beam Corner Plate	4
G		Cross Beam Center Connector Plate	4
H		Bar Shelf	2
H1		Bar Support Stand	1
H2		Bar Connector	2
I		Awning Frame - Left Side	1
I1		Awning Frame - Right Side	1
I2		Awning Corner Connector	2

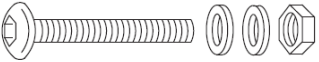
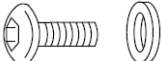
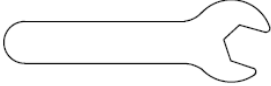
Letter	Illustration	Description	Qty.
J		Awning Frame - Left (Front and Back)	2
J1		Awning Frame – Right (Front and Back)	2
K		Awning Frame – Center	1
L		Awning Hydraulic Rod	2
M		Awning Lock	1
N		Base Plate	4
O		Base Cover	4
P		Main Roof Canopy	1
P1		Upper Roof Vent Canopy	1
Q		Awning Canopy	1
R		M6 x 15 mm Bolt with Washer	112
S		M6 x 32 mm Bolt with Nut and Washers	8

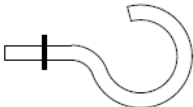
Letter	Illustration	Description	Qty.
T		M6 x 60 mm Bolt with Nut and Washers	2
U		M6 x 15mm Bolt with Washer	8
V		M6 Hex Wrench	2
W		Allen Wrench	1
X		Ground Stake	16
Y		Accessory Hook	1



# Assembly Instructions

## 10' x 10' Gazebo with Awning and Bar

Note: For video instructions please visit:

<https://shadenshelters.com/conley-gazebo-with-awning>

### Important:

- Read all the instructions before assembly. Failure to do so may result in faulty assembly and potential injury.
- Before assembling the product, remove all protective materials, hardware kit(s), and identify all parts packed in the carton are present. (Note: If any part is missing or damaged, do not attempt to assemble). Contact Shade N' Shelter Customer Support. See page 19.
- Assemble on a stable level surface to avoid damage to gazebo and possible injury.
- Two people are required to assemble this product.
- Gazebo dimensions are measured from the end of corner post base covers.

**DO NOT TIGHTEN BOLTS UNTIL NOTED AFTER EACH STEP**

**Step 1:** Insert Corner Posts (E, E1 and E2) into Base Cover (O) and raise them up. Attach Base Plate (N) to Corner Posts (E, E1 and E2) using Bolt and Washer (R). See Figure 1. **Tighten Bolts.**

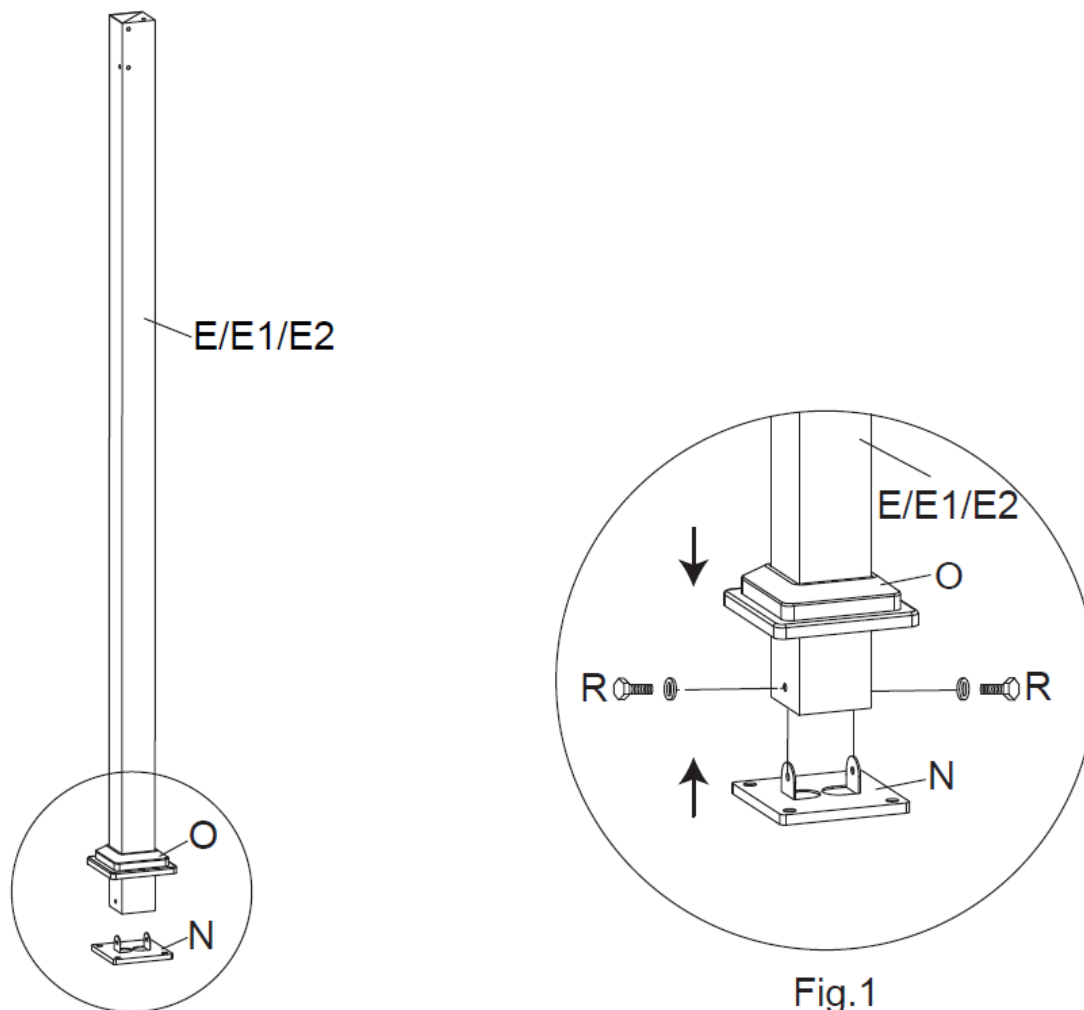

Fig.1

**Step 2:** Insert Cross Beam Center Connector Plate (G) into Cross Beam (D and D1) using Bolt and Washer (R). Repeat for remaining cross beams (D and D1). Insert Cross Beam Center Connector Plate (G) into Cross Beam (D2 and D3) using Bolt and Washer (R). See Figure 2. **Tighten Bolts.**

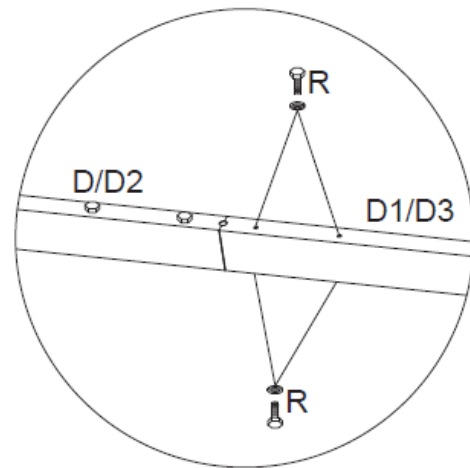
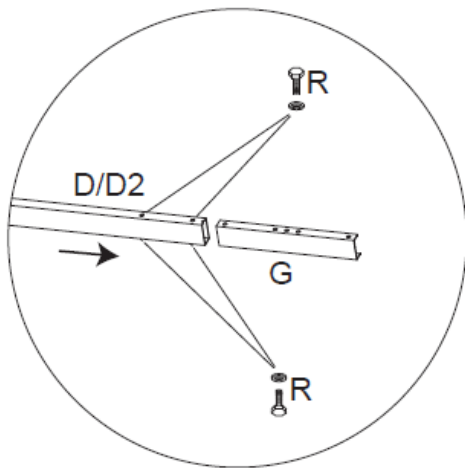
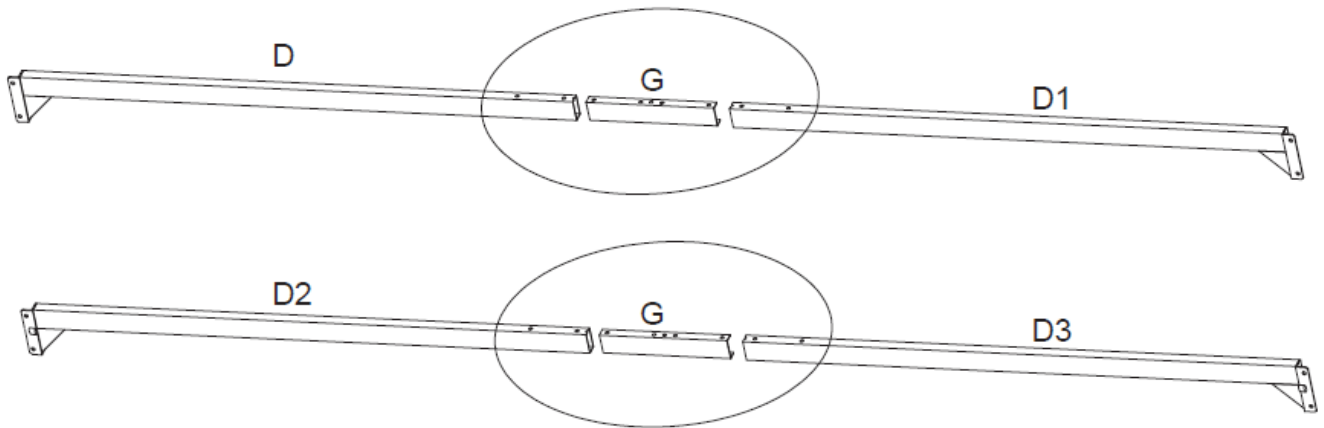

Fig.2

**Step 3A:** Attach Cross Beams (D and D1) to Corner Posts (E and E) using Bolt and Washer (R). Repeat for corner Posts (E and E1) and (E and E2). See Figure 3 and Figure 4.

**DO NOT TIGHTEN BOLTS UNTIL AFTER STEP 4**

**Step 3B:** Attach Cross Beams (D2 and D3) to Corner Post (E1 and E2) using Bolt and Washer (R). See Figure 3 and Figure 4.

**Note:** Bar Shelf connector holes must face each other on Corner Posts (E1 and E2). See Figure 4A. This is required for installing bar shelves.

**DO NOT TIGHTEN BOLTS UNTIL AFTER STEP 4**

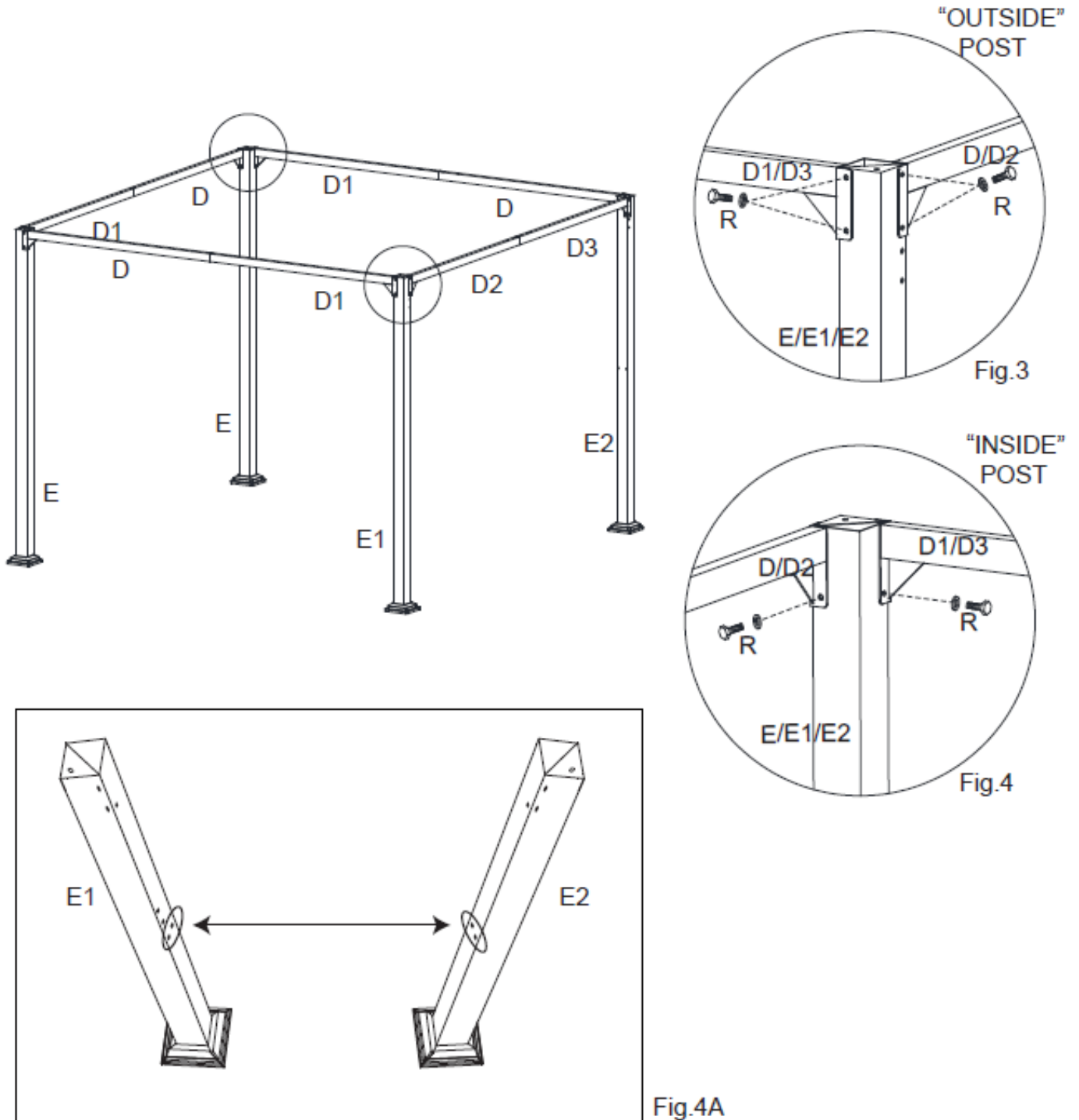

**Step 4A:** Connect the U-Shaped Connector (F) to the top of the Corner Posts using Bolt and Washer (U).  
Repeat for three remaining corner posts. See Figure 5.1.

**Step 4B:** Connect the U-Shaped Connector (F) to the center of the Cross Beams using Bolt and Washer (U).  
Repeat for three remaining Cross Beams. See Figure 5.2.

**Step 4C:** Connect Cross Beam Corner Plates (F1) across the top of the beams using Bolt and Washer (R).  
Repeat for each corner. See Figure 6.

**TIGHTEN ALL BOLTS FROM STEP 3 AND STEP 4**

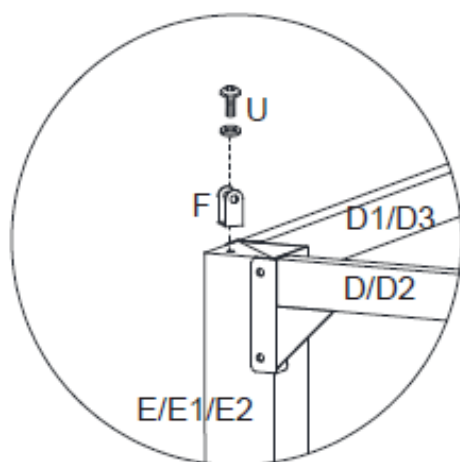
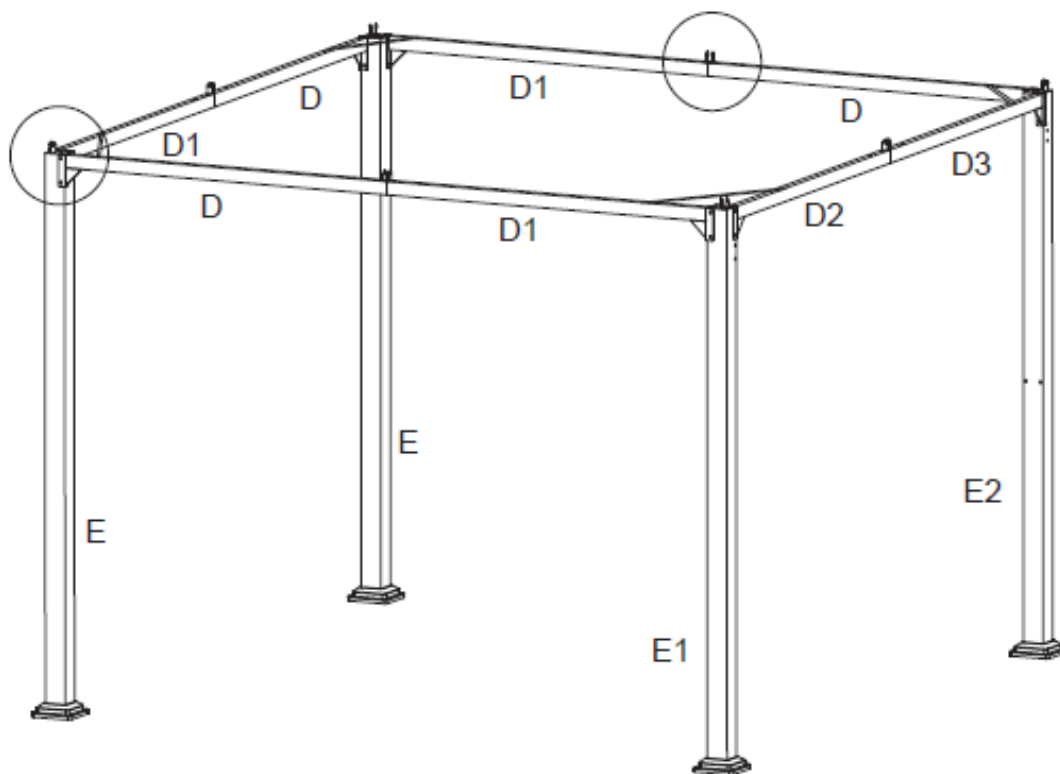

Fig.5.1

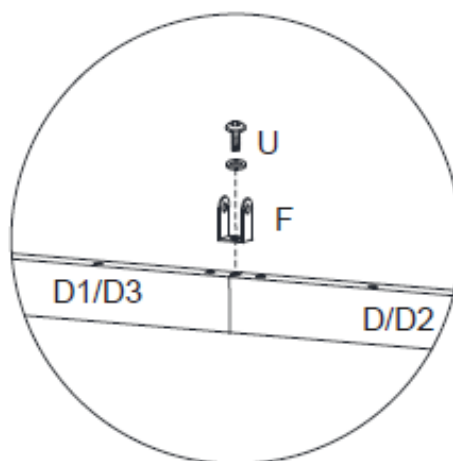

Fig.5.2

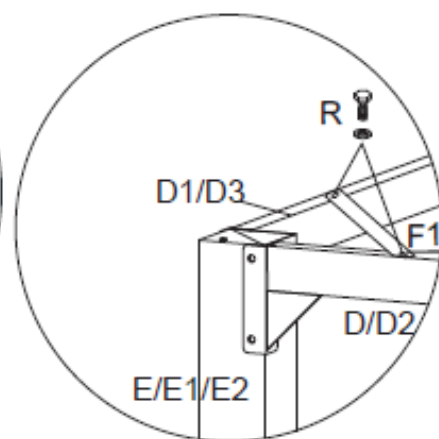

Fig.6

**Step 5A:** Screw the Accessory Hook (Y) into the Main Roof Connector (A). Insert the Main Corner Roof Support (B) into Main Roof Connector (A) until the "push button" lock clicks. Repeat for the three remaining Main Roof Corner Supports (B). See Figure 7.

**Step 5B:** This step requires two people. One person (with the use of a ladder) holds the Main Roof Connector (A) and the corner supports (above the cross beams) while the second person inserts one Main Roof Corner Support Extension (B1) into a Main Roof Corner Support (B) and attaches it to the U-Shaped Connector (F) on top of the Corner Posts using Bolt, Nut, and Washers (S). Repeat for three remaining extensions (B1). See Figure 8. **TIGHTEN BOLTS.**

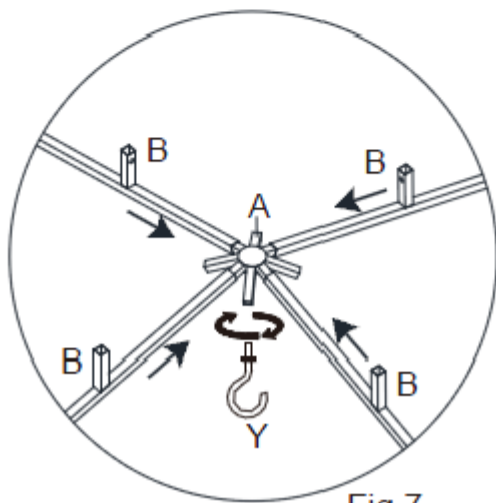
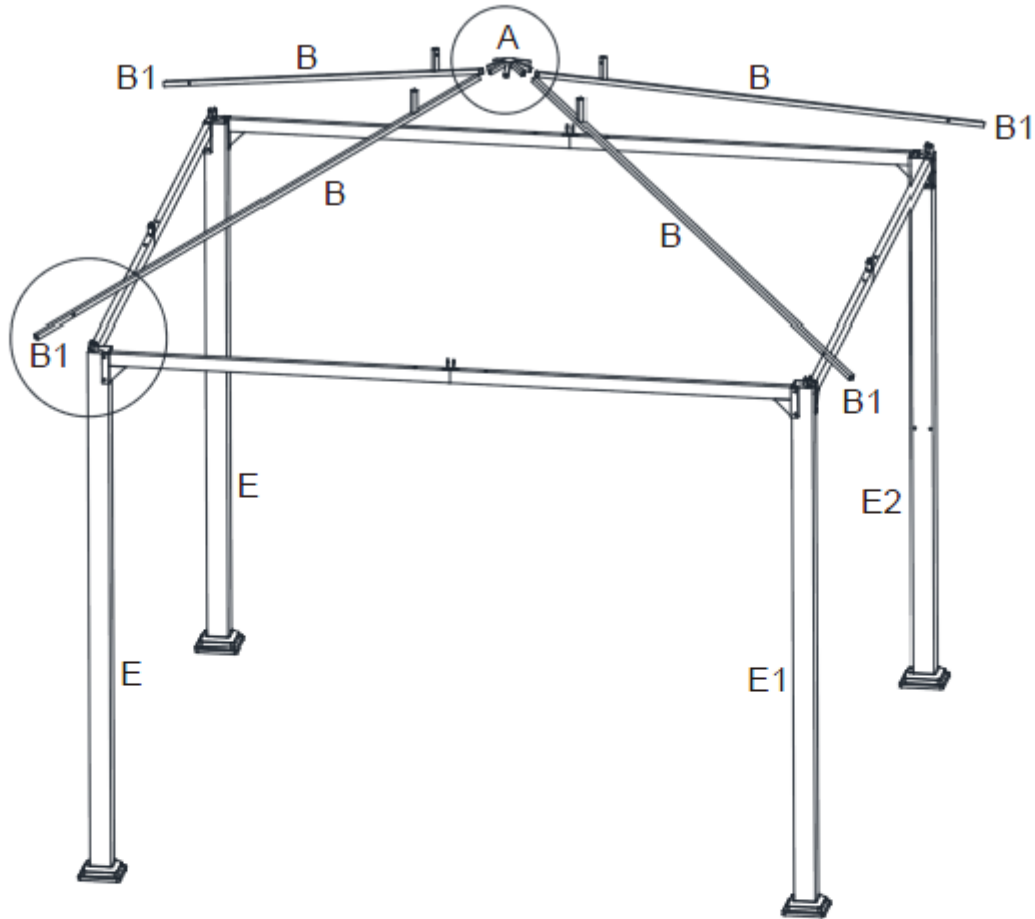

Fig.7

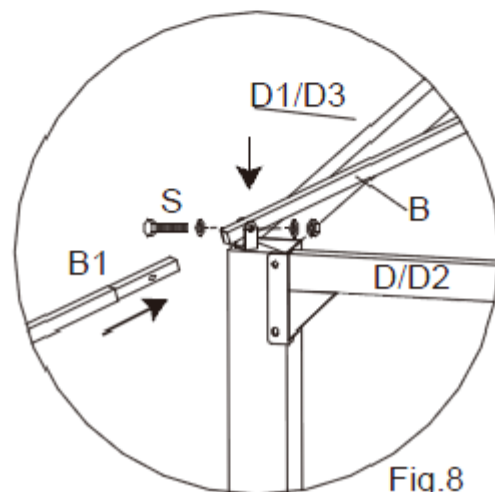

Fig.8

**Step 6:** Insert Main Roof Side Support (C) into the Main Roof Connector (A) until the "push button" lock clicks. Attach the opposite end of the Main Roof Side Support (C) to the U-Shaped Connector (F) in the center of the cross beam using Bolt, Nut, and Washers (S). Repeat for three remaining Side Supports (C). See Figure 9 and Figure 10. **TIGHTEN BOLTS.**

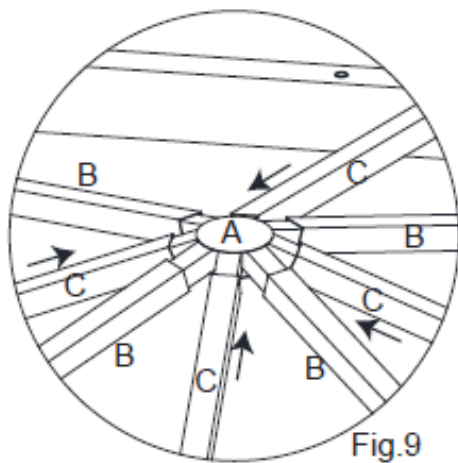
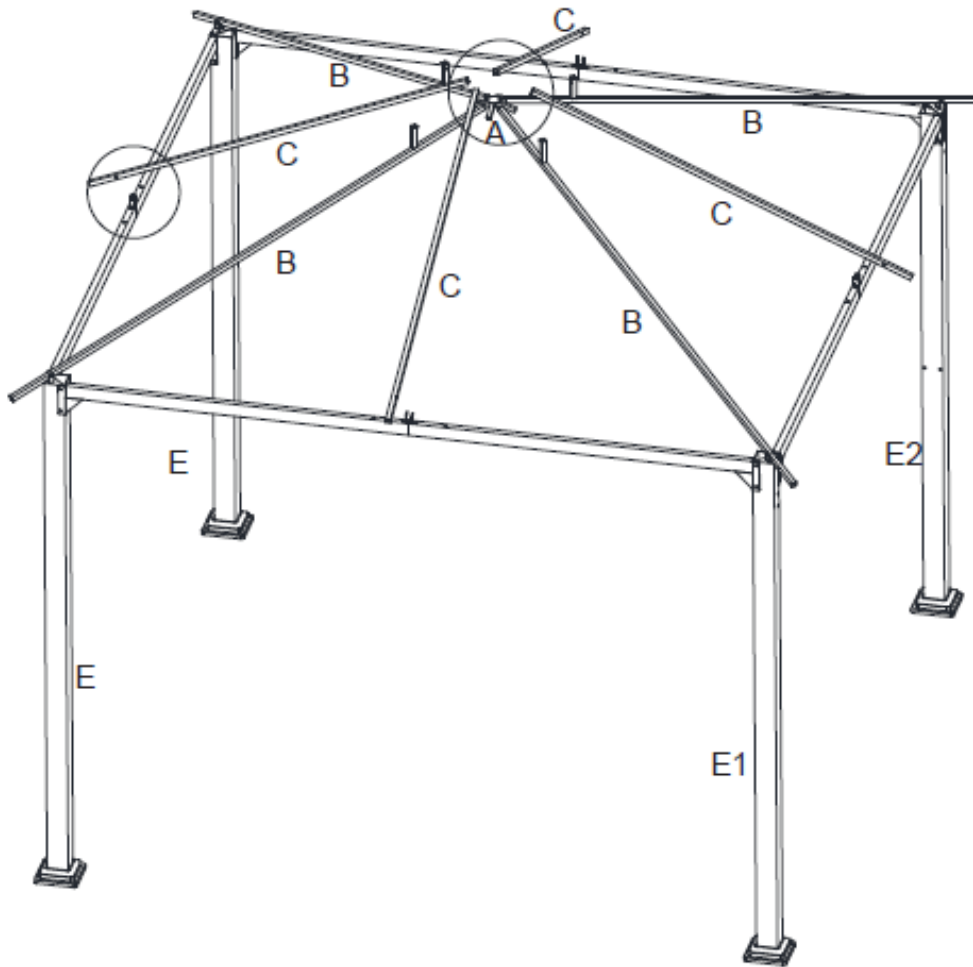

Fig.9

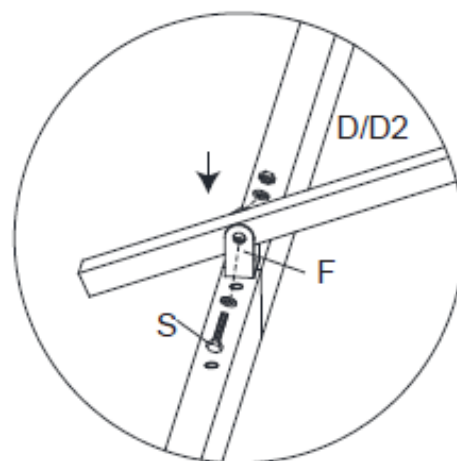
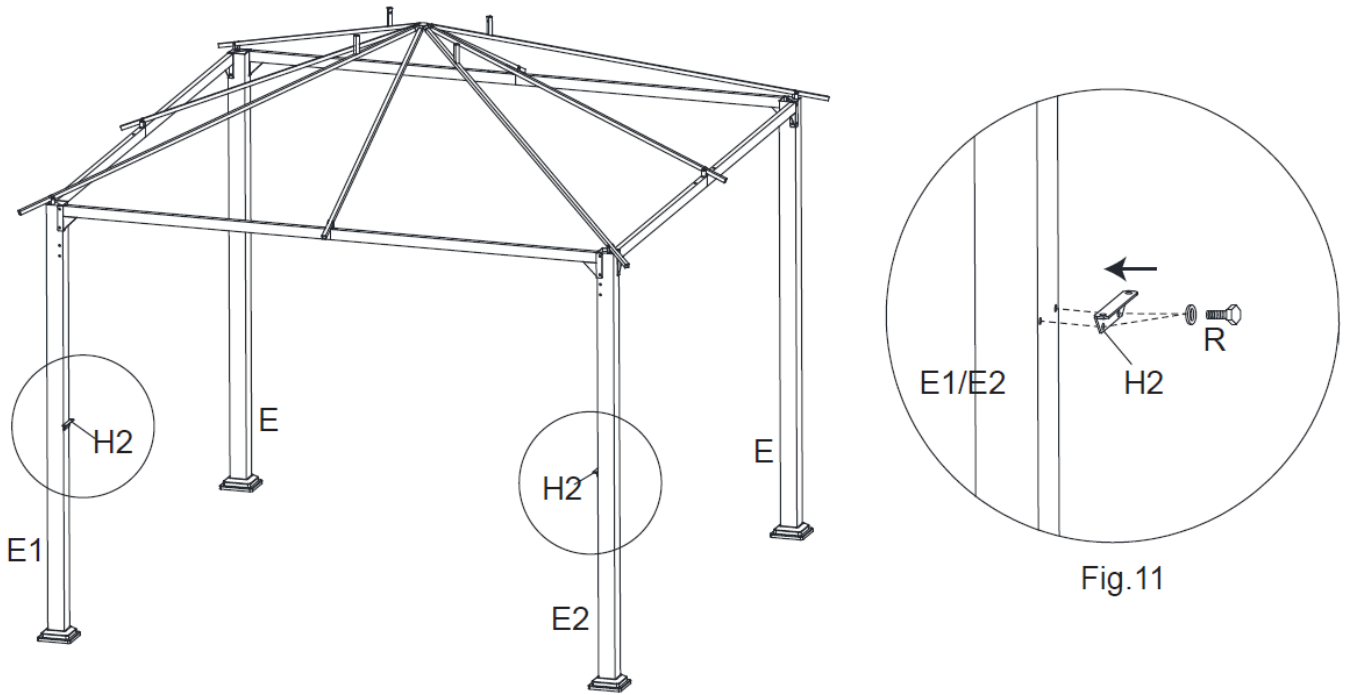
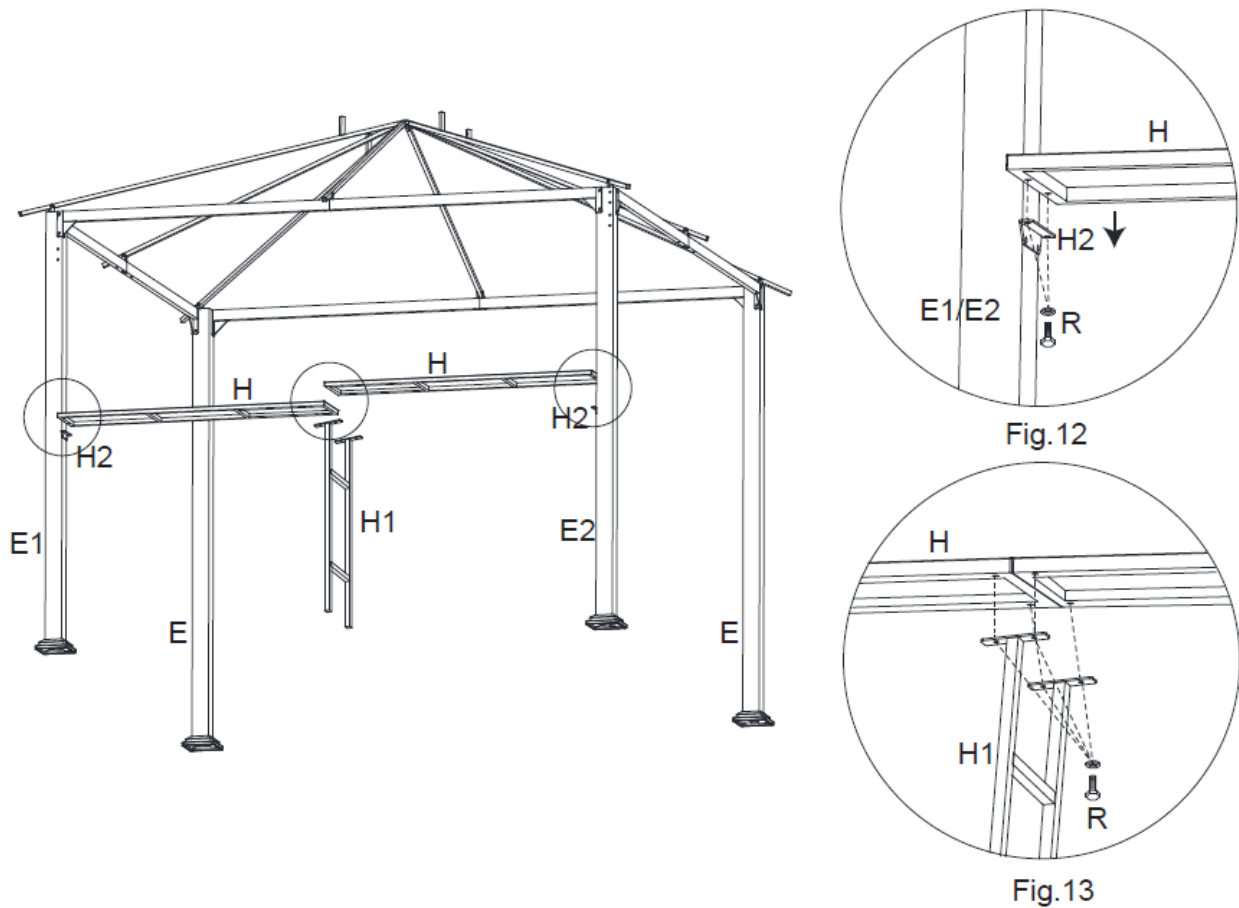

Fig.10

**Step 7:** Connect the Bar Connector (H2) to the Corner Post (E1 and E2) and tighten with Bolt and Washer (R). See Figure 11. **TIGHTEN BOLTS.**



**Step 8:** Using two people connect one end of the Bar Shelf (H) to Bar Connector (H2) using Bolt and Washer (R). Attach opposite end to the Bar Support Stand (H1) using Bolt and Washer (R). Repeat for second Bar Shelf (H). See Figure 12 and Figure 13. **TIGHTEN BOLTS.**



**Step 9:** Assemble Upper Roof Frame:

Insert Upper Roof Support (A2) to Upper Roof Connector (A1) until the “push button” lock clicks.  
Repeat for three remaining supports.

Attach Upper Roof Vent Canopy (P1) to the upper roof frame. See Figure 14.

Screw the Finial (A3) into the upper roof frame. See Figure 15.

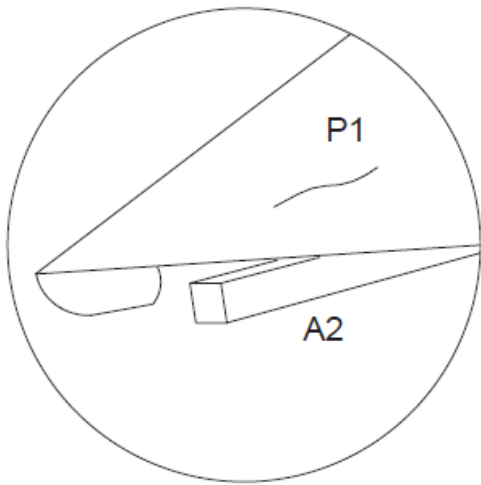
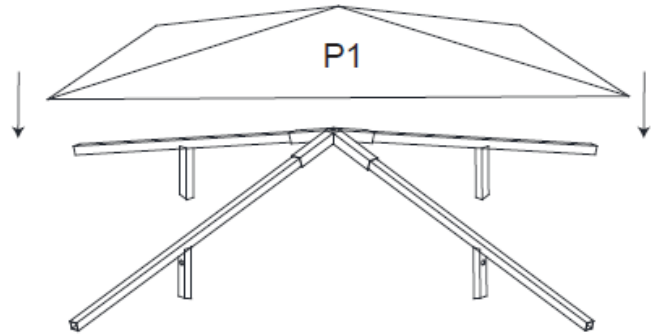
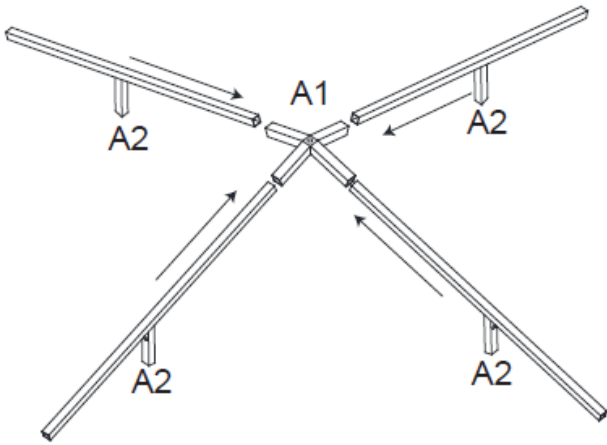

Fig.14

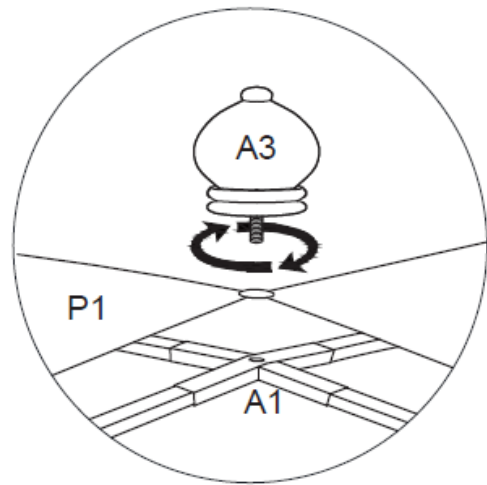
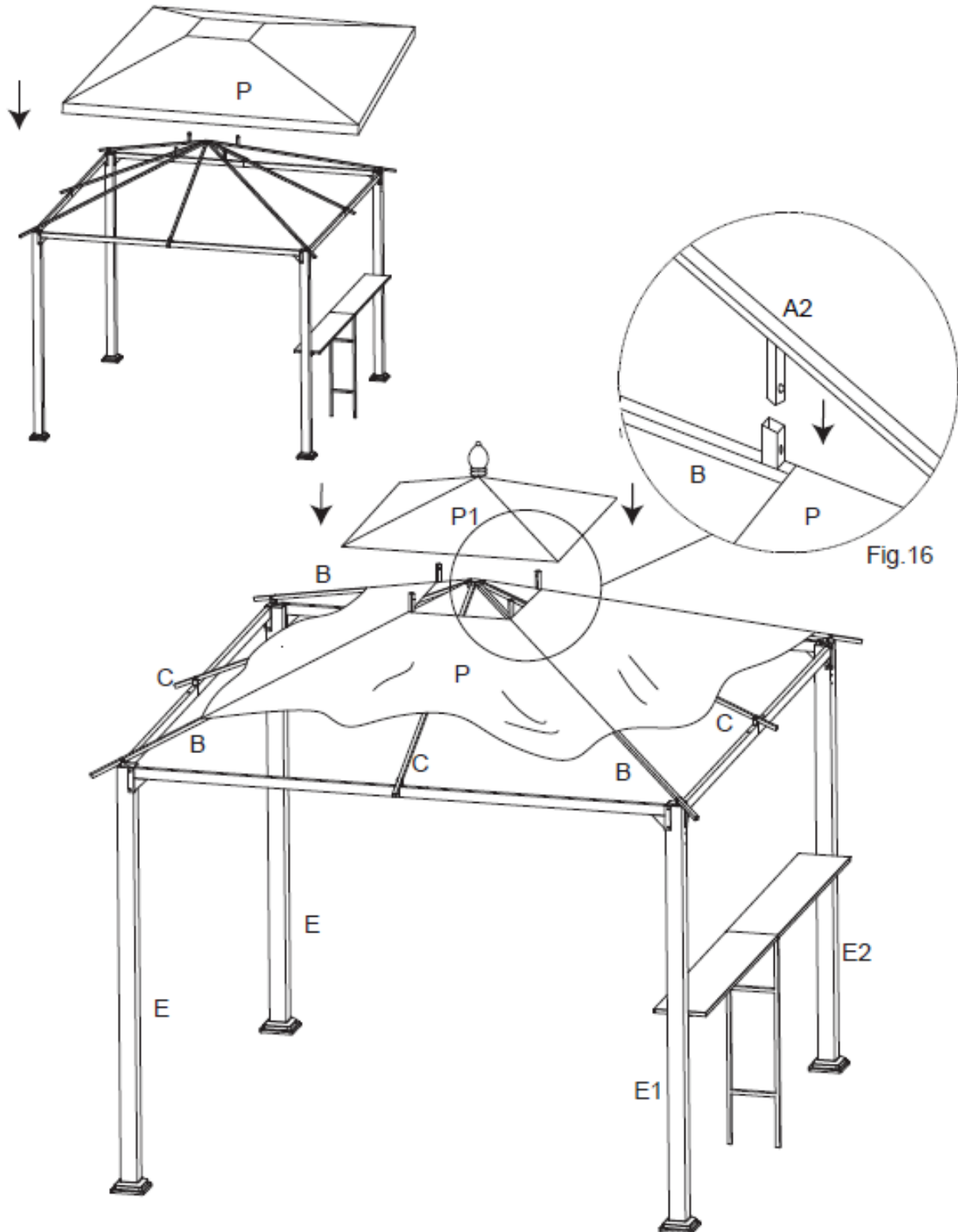

Fig.15

**Step 10A:** Place the Main Roof Canopy (P) over main roof frame.

**Note:** The Main Roof Canopy (P) has two "open" corner seams. The "open" corner seams are placed over Corner Posts (E1 and E2). Do not secure the Main Roof Canopy (P) until the upper roof frame is installed.

**Step 10B:** Attach assembled upper roof frame by inserting the Upper Roof Support (A2) into the Main Roof Corner Supports (B) until the "push button" lock clicks. Repeat for each corner. See Figure 16.



**Step 11A:** Secure the Main Roof Canopy (P) to the four Main Roof Corner Support Extensions (B1). See Figure 17.

**Step 11B:** Secure the Main Roof Canopy (P) to the four Main Roof Side Supports (C). See Figure 18.

**Note:** Canopy will be tight once secured to the roof frame.

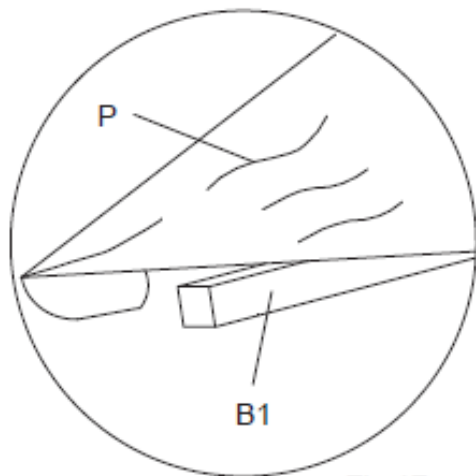
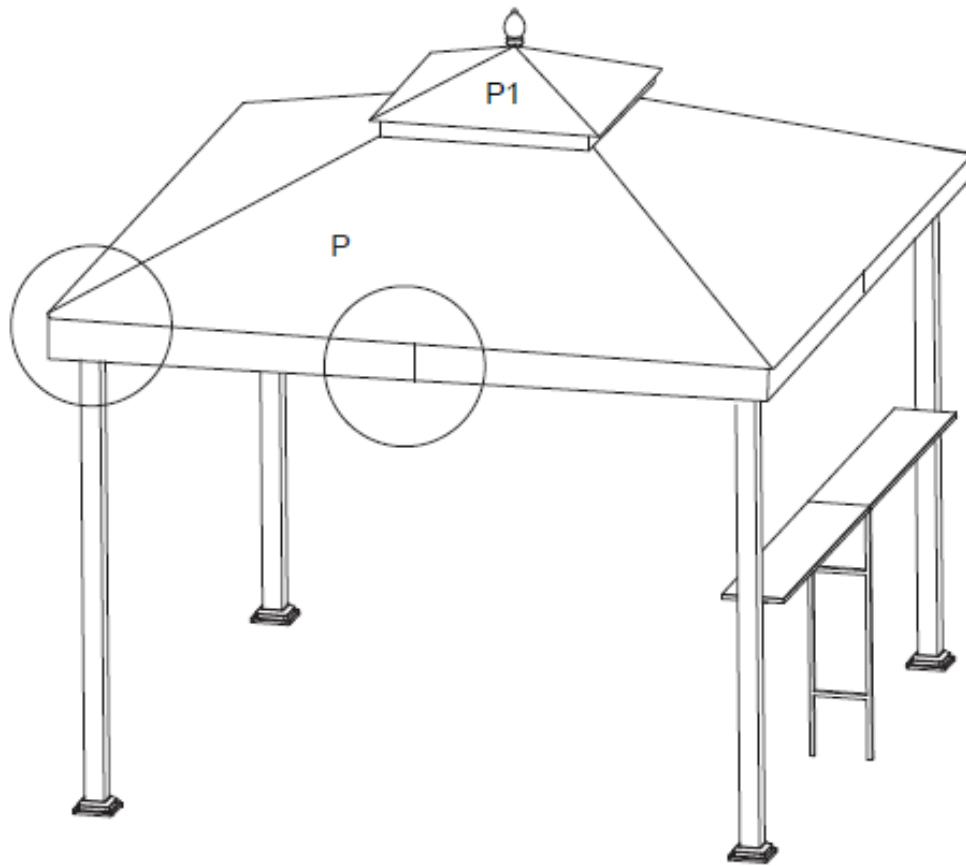

Fig.17

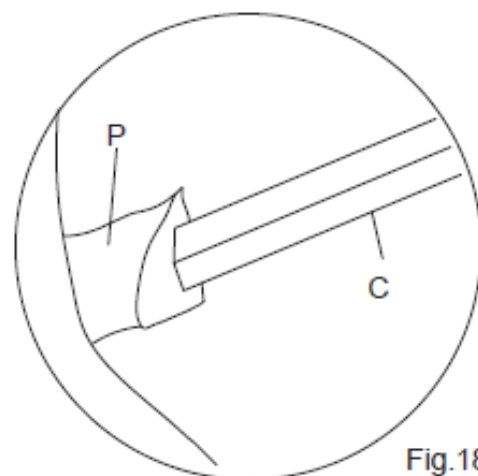

Fig.18

**Step 12:** Awning Assembly

**Note:** Assemble awning frame before attaching awning canopy (Q).

**Step 12A:** Attach Left Awning Frame (I) to Back Awning Frame (J) with Bolts and Washers (R). Repeat for Right Awning Frame (I1) and Back Awning Frame (J1). See Figure 19.

**Step 12B:** Attach Back Awning Frame (J) to the Back Awning Frame (J1) and the Center Awning Frame (K) with Bolts and Washers (R). Repeat for the front awning frame. See Figure 20 and Figure 21.

**Step 12C:** Attach Awning Corner Connector (I2) to Right Side Awning Frame (I1) and Front Awning Frame (J1) using Bolts and Washers (R). See Figure 22.

Repeat for second Awning Corner Connector (I2) to Left Side Awning Frame (I) and Front Awning Frame (J) using Bolts and Washers (R). **TIGHTEN BOLTS.**

**Step 12D:** Place Awning Canopy (Q) over assembled awning frame and secure with velcro.

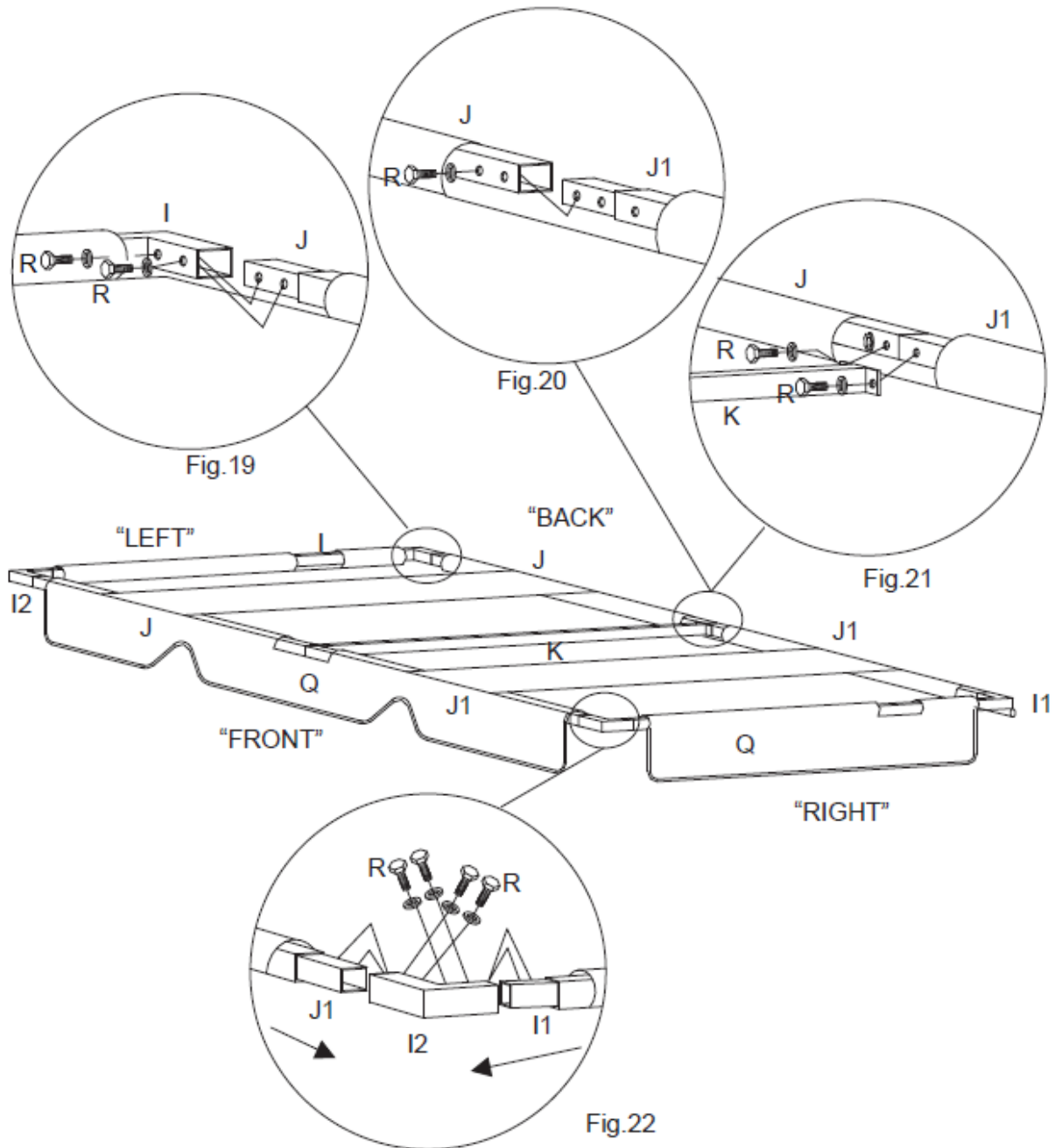

**Step 13:** Using two people attach assembled awning to gazebo.

**Step 13A:** Connect the back of awning to Corner Posts (E1 and E2) using Bolt, Nut and Washer (T). See Figure 23.1.

**Step 13B:** Connect one end of the Awning Hydraulic Rod (L) to Corner Post (E1) and the opposite end to awning frame using Bolts and Washers (R). Repeat for second Hydraulic Rod (L) on Corner Post (E2). See Figure 23.2.

**Step 13C:** Attach the Awning Lock (M) to Corner Posts (E1) using Bolts and Washers (R). See Figure 24.1. **TIGHTEN BOLTS.**

**Step 13D:** When awning is in the closed position use the Awning Lock (M) to secure awning to gazebo frame. See Figure 24.2.

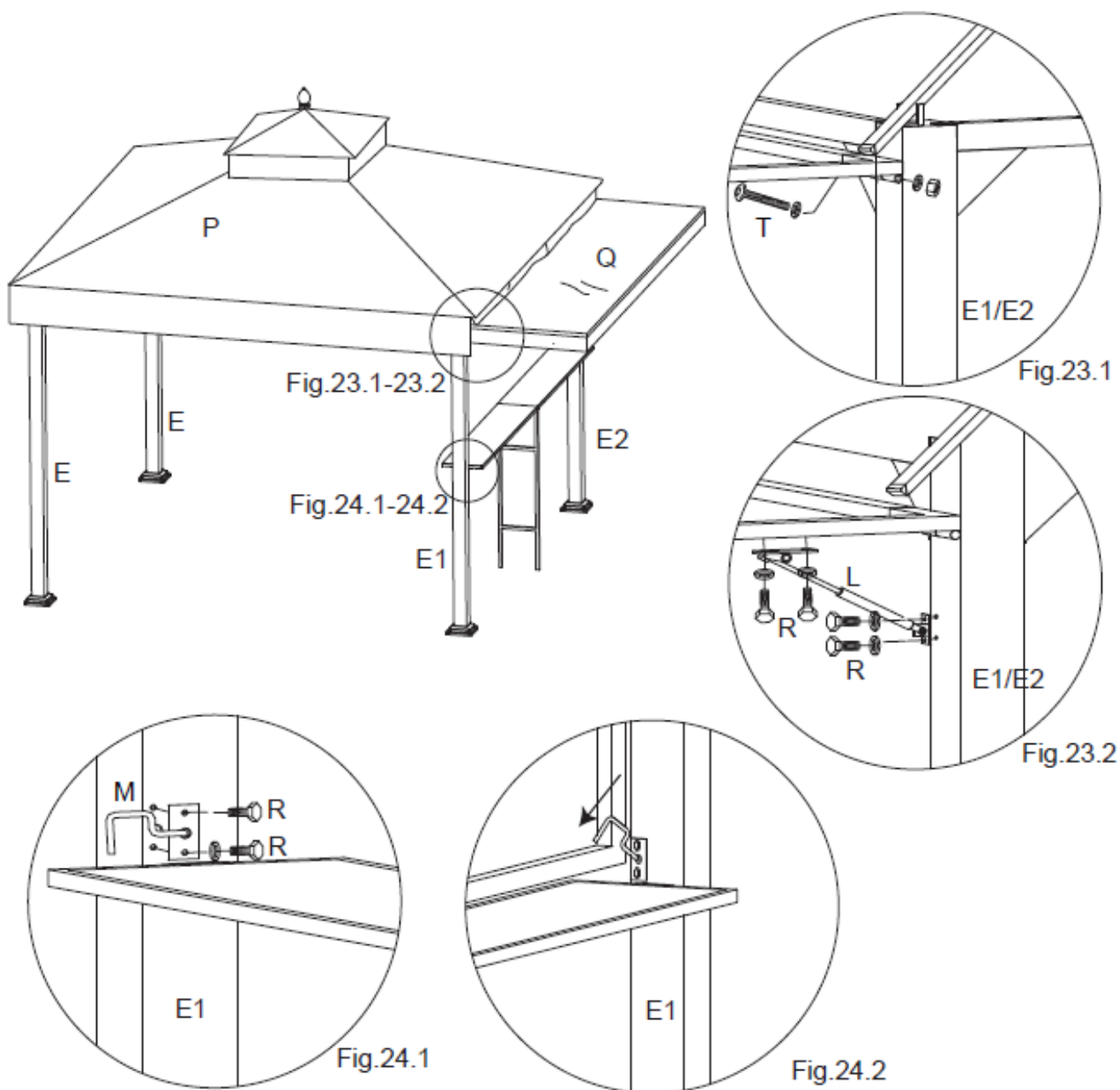

**Step 14:** Insert four Stakes (X) into the ground through the Base Plate (N). Repeat for each corner. See Figure 25.

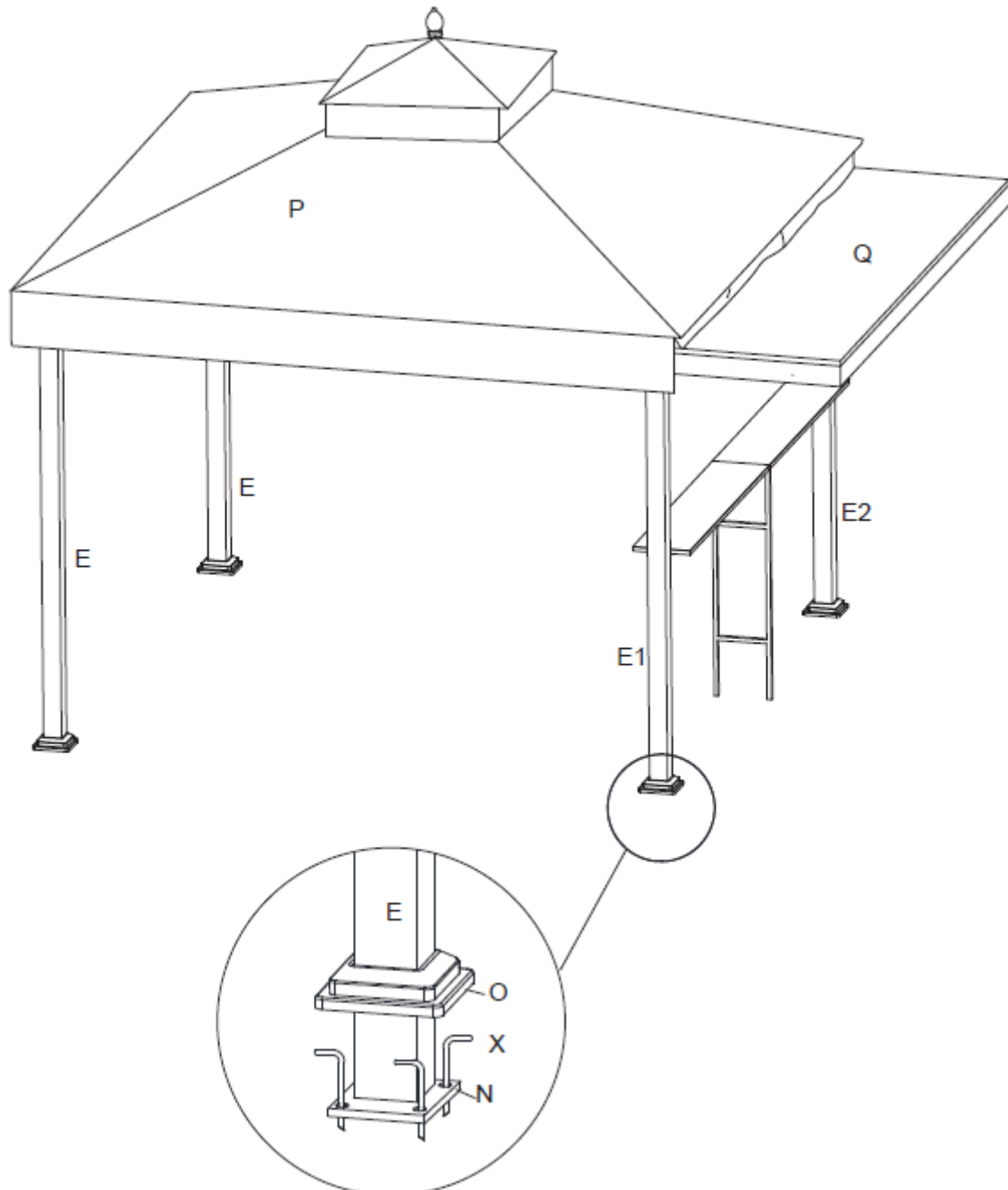

Fig.25

**Note: Please see our video for additional assembly assistance:**

<https://shadenshelters.com/conley-gazebo-with-awning>

## **Maintenance & Care**

Maintenance is required for all outdoor gazebo/pergola/pavilion. Inspect hardware thoroughly before use and during the season to make sure bolts are securely fastened. Remove fabric canopy from soft top gazebo and store out of the elements when not in use or during hazardous weather conditions (wind, rain, snow, etc.). Remove all snow from the hard top gazebo/pavilion. Failure to maintain the gazebo/pergola/pavilion will void warranty.

**Steel/Aluminum Frame:** Clean frames with a mild soap and warm water. Do not use abrasive materials, cleaners or bleach. Rinse with clean water and dry thoroughly.

**Wood Frame:** The wood contains a water sealant. Over time direct sunlight and outdoor elements will dry and potentially create slight cracks in the wood. **A stain or water sealant must be applied annually to extend the life of the wood frame and for warranty.**

**Fabric:** Clean fabric by hand with a mild solution of soap and water. Rinse thoroughly and allow to drip dry. Do not machine wash or tumble dry, as fabric may shrink. Do not use bleach or solvents on fabric.

## **Warranty**

**LIMITED 1 YEAR WARRANTY:** The manufacturer will replace any part found to be defective in material or workmanship within 30 days of purchase date. The purchaser must contact the manufacturer's customer service department. After 30 days of purchase date the warranty is limited. The manufacturer, at its option, will repair or replace the defective parts. Proof of purchase (dated register receipt) and photos are required for all warranty claims. It remains the customer's responsibility to pay for freight and packaging charges to and from the service center. The warranty is to the original purchaser and is non-transferable. Any replacement or warranted items will be in the original style and color, or similar style and color if the original is unavailable or has been discontinued. **Please contact our Customer Service for assembly assistance or replacement parts. Do not return to the store without authorization.**

**EXCLUSIONS:** Gazebos/Pergolas/Pavilions used for commercial, contract, or other non-residential purposes are excluded. Damage due to acts of nature, misuse, improper assembly or maintenance, collapse, settling of ground or base structure. Discoloration, fading, mildew, corrosion and rusting are excluded

**LIABILITY:** Inside Out Intl LLC, Shade N Shelters LLC, and Retailer disclaim any and all liability for personal injury, property damage or loss resulting from the incorrect attachment, improper use, inadequate maintenance, unapproved modification, or neglect of this product.

## **Accessories**

Privacy Curtains, Winter Covers, Winter Support Poles, and Replacement Mosquito Netting are available for select items. Please visit your retailer's website or contact [service@shadenshelters.com](mailto:service@shadenshelters.com) for more information.

## **Customer Service Contact Information**

Hours: Monday - Friday 8:00 a.m. - 5:00 p.m. Central Time (CT)

Phone: 1-888-607-4417

Email: [service@shadenshelters.com](mailto:service@shadenshelters.com)