

Microwave Oven

use & care

Introduction	2	Cleaning And Care27
Precautions Microwave Energy	3	Service Call Check28
Important Safety Instructions	4-7	Warranty29
Names Of Oven Parts And Accessories	8-9		
Operation	10-25		
Maintenance26		



2 INTRODUCTION

Welcome to our *family*

Thank you for bringing Frigidaire into your home! We see your purchase as the beginning of a long relationship together.

This manual is your resource for the use and care of your product. Please read it before using your appliance. Keep it handy for quick reference. If something doesn't seem right, the troubleshooting section will help you with common issues.

FAQs, helpful tips and videos, cleaning products, and kitchen and home accessories are available at www.frigidaire.com.

We are here for you! Visit our website, chat with an agent, or call us if you need help. We may be able to help you avoid a service visit. If you do need service, we can get that started for you.

Let's make it official! Be sure to register your product.

Keep your product info here so it's easy to find.

Model Number: _____

Serial Number: _____

Purchase Date: _____

Let's make it official! Be sure to register your product.

Visit us at Frigidaire.com/register

Or use your mobile device to scan the QR code.

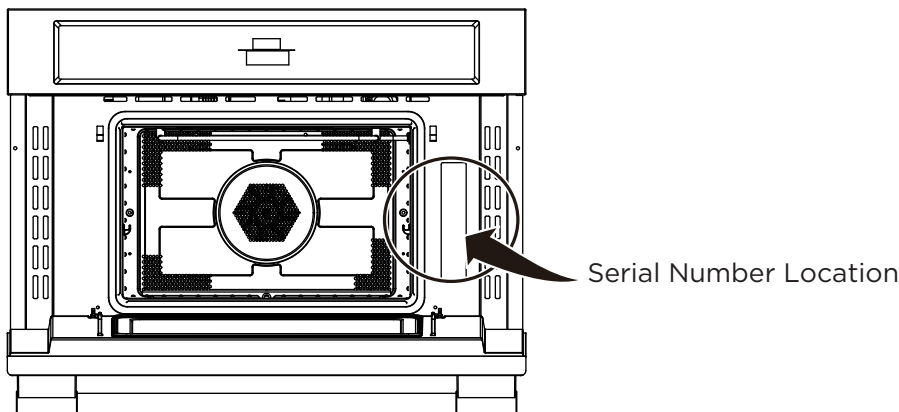

PRECAUTIONS TO AVOID POSSIBLE EXPOSURE TO EXCESSIVE MICROWAVE ENERGY

Do not attempt to operate this oven with the door open since open door operation can result in harmful exposure to microwave energy. It is important not to defeat or tamper with the safety interlocks.

Do not place any object between the oven front face and the door or allow soil or cleaner residue to accumulate on sealing surfaces.

WARNING

To reduce the risk of burns, electric shock, fire, injury to persons or exposure to excessive microwave energy:

Do not operate the oven if it is damaged. It is particularly important that the oven door close properly and that there is no damage to the:

- (1) DOOR (bent)
- (2) HINGES AND LATCHES (broken or loosened)
- (3) DOOR SEALS AND SEALING SURFACES.

The oven should not be adjusted or repaired by anyone except properly qualified service personnel.

This device complies with part 18 of the FCC Rules. (Only for USA)

RADIO INTERFERENCE

- Operation of the microwave oven may cause interference to your radio, TV or similar equipment.
- When there is interference, it may be reduced or eliminated by taking the following measures:
 - Clean door and sealing surface of the oven.
 - Reorient the receiving antenna of radio or television.
 - Relocate the microwave oven with respect to the receiver.
 - Move the microwave oven away from the receiver.
 - Plug the microwave oven into a different outlet so that microwave oven and receiver are on different branch circuits.

UTENSILS

CAUTION

- Personal Injury Hazard

- Tightly-closed utensils could explode. Closed containers should be opened and plastic pouches should be pierced before cooking.
- See the instructions on "Materials you can use in microwave oven or to be avoided in microwave oven."

There may be certain non-metallic utensils that are not safe to use for microwaving. If in doubt, you can test the utensil in question following the procedure below.

Utensil Test:

- Fill a microwave-safe container with 1 cup of cold water (250ml) along with the utensil in question.
- Cook on maximum power for 1 minute.
- Carefully feel the utensil. If the empty utensil is warm, do not use it for microwave cooking.
- Do not exceed 1 minute cooking time.

SAVE THESE INSTRUCTIONS

4 IMPORTANT SAFETY INSTRUCTIONS

Read all instructions before using this appliance.

This manual contains important safety symbols and instructions. Please pay attention to these symbols and follow all instructions given.

Do not attempt to install or operate your appliance until you have read the safety precautions in this manual. Safety items throughout this manual are labeled with a WARNING or CAUTION statement based on the risk type.

Warnings and important instructions appearing in this guide are not meant to cover all possible conditions and situations that may occur. Common sense, caution, and care must be exercised with installing, maintaining, or operating your appliance.

DEFINITIONS

 This is the safety alert symbol. It is used to alert of potential personal injury hazards. Obey all safety messages that follow this symbol to avoid possible injury or death.

WARNING

Indicates a potentially hazardous situation which, if not avoided, may result in death or serious injury.

CAUTION

Indicates a potentially hazardous situation which, if not avoided, may result in minor or moderate injury.

NOTE

Indicates a short, informal reference - something written down to assist the memory or for future reference.

IMPORTANT

Indicates installation, operation or maintenance information which is important but not hazard-related.

NOTE

ELECTRICAL REQUIREMENTS

Product rating is 120V, 60Hz, AC only, 20 amp. This product must be connected to a separate and dedicated supply circuit of the proper voltage and frequency.

Wire size must conform to the requirements of the National Electrical Code or the prevailing local code for this kilowatt rating. The power supply cord and plug should be brought to a separate and dedicated 20-ampere branch circuit single grounded outlet. The outlet box should be located in the cabinet above the microwave oven. The outlet box and supply circuit should be installed by a qualified electrician and conform to the National Electrical Code or the prevailing local code.

IMPORTANT

1. If you have any questions about the grounding or electrical instructions, consult a qualified electrician or service person.
2. Neither Electrolux nor the dealer can accept any liability for damage to the microwave oven or personal injury resulting from failure to observe the correct electrical connection procedures.

SAVE THESE INSTRUCTIONS

When using electrical appliances basic safety precautions should be followed, including the following:

WARNING

To reduce the risk of burns, electric shock, fire, injury to persons or exposure to excessive microwave energy:

- Read all instructions before using the appliance.
- Read and follow the specific: "PRECAUTIONS TO AVOID POSSIBLE EXPOSURE TO EXCESSIVE MICROWAVE ENERGY" found on page 3.
- This appliance must be grounded. Connect only to properly grounded outlet. See "GROUNDING INSTRUCTIONS" found on page 6.
- Install or locate this appliance only in accordance with the provided installation instructions.
- Some products such as whole eggs and sealed containers - for example, closed glass jars - are able to explode and should not be heated in this oven.
- Use this appliance only for its intended use as described in the manual. Do not use corrosive chemicals or vapors in this appliance. This type of oven is specifically designed to heat, cook or dry food. It is not designed for industrial or laboratory use.
- **HOT CONTENTS CAN CAUSE SEVERE BURNS. DO NOT ALLOW CHILDREN TO USE THE MICROWAVE.** Use caution when removing hot items.
- Do not operate this appliance if it has a damaged cord or plug, if it is not working properly, or if it has been damaged or dropped.
- This appliance should be serviced only by qualified service personnel. Contact nearest authorized service facility for examination, repair, or adjustment.
- Do not cover or block any openings on the appliance.
- Do not store this appliance outdoors. Do not use this product near water - for example, near a kitchen sink, in a wet basement, near a swimming pool, or similar location.
- Do not immerse cord or plug in water.
- Keep cord away from heated surface.
- Do not let cord hang over edge of table or counter. When cleaning surfaces of door and oven that comes together on closing the door, use only mild, nonabrasive soaps, or detergent applied with a sponge or soft cloth.
- To reduce the risk of fire in the oven cavity:
 - Do not overcook food. Carefully attend appliance when paper, plastic, or other combustible materials are placed inside the oven to facilitate cooking.
 - Remove wire twist-ties from paper or plastic bag before when placing bag in oven.
 - If material inside of the oven ignite, keep oven door closed, turn oven off, and disconnect the power cord, or shut off power at the fuse or circuit breaker panel.
 - Do not use the cavity for storage purposes. Do not leave paper products, cooking utensils, or food in the cavity when not in use.
- Liquids, such as water, coffee, or tea are able to be overheated beyond the boiling point without appearing to be boiling. Visible bubbling or boiling when the container is removed from the microwave oven is not always present. **THIS COULD RESULT IN VERY HOT LIQUID SUDDENLY BOILING OVER WHEN THE CONTAINER IS DISTURBED OR A UTENSIL IS INSERTED INTO THE LIQUID.** To reduce the risk of injury to persons:
 - Do not overheat the liquid.
 - Stir the liquid both before and halfway through heating it.
 - Do not use straight-sided containers with narrow necks.
 - After heating, allow the container to stand in the microwave oven for a short time before removing the container.
 - Use extreme care when inserting a spoon or other utensil into the container.
 - Oversized food or oversized metal utensils should not be inserted in a microwave oven as they may create a fire or risk of electric shock. Do not clean with metal scouring pads. Pieces can burn off the pad and touch electrical parts involving a risk of electric shock.
 - Do not store any materials, other than manufacturer's recommended accessories, in this oven when not in use.
 - Do not cover racks or any other part of the oven with metal foil. This will cause over- heating of the oven.
 - Clean Ventilation Hoods Frequently -Grease should not be allowed to accumulate on hood or filter.
 - When flaming foods under the hood, turn the fan on.
 - Use care when cleaning the vent-hood filter. Corrosive cleaning agents, such as lye-based oven cleaners, may damage the filter.
 - Suitable for use above both gas and electric cooking equipment.

6 IMPORTANT SAFETY INSTRUCTIONS

GROUNDING INSTRUCTIONS

This appliance must be grounded. In the event of an electrical short circuit, grounding reduces the risk of electric shock by providing an escape wire for the electric current. This appliance is equipped with a cord having a grounding wire with a grounding plug. The plug must be plugged into an outlet that is properly installed and grounded.

WARNING

Improper use of the grounding can result in a risk of electric shock.

Consult a qualified electrician or serviceman if the grounding instructions are not completely understood, or if doubt exists as to whether the appliance is properly grounded. If it is necessary to use an extension cord, use only a 3-wire extension cord that has a 3-blade grounded plug, and 3-slot receptacle that will accept the plug on the appliance. The marked rating of the extension cord shall be equal to or greater than the electrical rating of the appliance.

IMPORTANT

1. If you have any questions about the grounding or electrical instructions, consult a qualified electrician or service person.
2. Neither Electrolux nor the dealer can accept any liability for damage to the microwave oven or personal injury resulting from failure to observe the correct electrical connection procedures.

DANGER

Electric Shock Hazard

Touching some of the internal components can cause serious personal injury or death. Do not disassemble this appliance.

WARNING

Electric Shock Hazard

Improper use of the grounding can result in electric shock. Do not plug into an outlet until appliance is properly installed and grounded.

ABOUT YOUR MICROWAVE OVEN

This Use and Care Manual is valuable: read it carefully and always save it for reference. A good microwave cookbook is a valuable asset. Check it for microwave cooking principles, techniques, hints and recipes.

NEVER use the microwave oven without the turntable and support nor turn the turntable over so that a large dish could be placed in the microwave oven. The turntable will turn both clockwise and counterclockwise.

ALWAYS have food in the microwave oven when it is on to absorb the microwave energy. When using the microwave oven at power levels below 100%, you may hear the magnetron cycling on and off. It is normal for the exterior of the microwave oven to be warm to the touch when cooking or reheating. Condensation is a normal part of microwave cooking. Room humidity and the moisture in food will influence the amount of moisture that condenses in the microwave oven. Generally, covered foods will not cause as much condensation as uncovered ones. Ventilation openings must not be blocked. The microwave oven is for food preparation only. It should not be used to dry clothes or newspapers.

SAVE THESE INSTRUCTIONS

Materials you can use in microwave oven

Browning dish	Follow manufacturer instructions. The bottom of browning dish must be at least 3/16 inch (5mm) above the turntable. Incorrect usage may cause the turntable to break.
Dinnerware	Microwave-safe only. Follow manufacturer's instructions. Do not use cracked or chipped dishes.
Glass jars	Always remove lid. Use only to heat food until just warm. Most glass jars are not heat resistant and may break.
Glassware	Heat-resistant oven glassware only. Make sure there is no metallic trim. Do not use cracked or chipped dishes.
Oven cooking bags	Follow manufacturer instructions. Do not close with metal tie. Make slits to allow steam to escape.
Paper plates and cups	Use for short term cooking/warming only. Do not leave oven unattended while cooking.
Paper towels	Use to cover food for reheating and absorbing fat. Use with supervision for a short-term cooking only.
Parchment paper	Use as a cover to prevent splattering or a wrap for steaming.
Plastic	Microwave-safe only. Follow the manufacturer instructions. Should be labeled "Microwave Safe". Some plastic containers soften, as the food inside gets hot. "Boiling bags" and tightly closed plastic bags should be slit, pierced or vented as directed by package.
Plastic wrap	Microwave-safe only. Use to cover food during cooking to retain moisture. Do not allow plastic wrap to touch food.
Thermometers	Microwave-safe only (meat and candy thermometers).
Wax paper	Use as a cover to prevent splattering and retain moisture.

Materials to be avoided in microwave oven

Aluminum tray	May cause arcing. Transfer food into microwave-safe dish.
Food carton with metal handle	May cause arcing. Transfer food into microwave-safe dish.
Metal or metal-trimmed utensils	Metal shields the food from microwave energy. Metal trim may cause arcing.
Metal twist ties	May cause arcing and could cause a fire in the oven.
Paper bags	May cause a fire in the oven.
Plastic foam	Plastic foam may melt or contaminate the liquid inside when exposed to high temperature.
Wood	Wood will dry out when used in the microwave oven and may split or crack.

8

NAMES OF OVEN PARTS AND ACCESSORIES

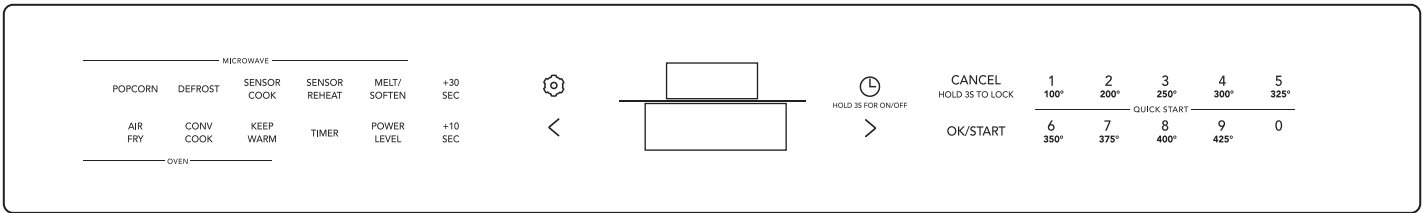

Ceramic microwave tray

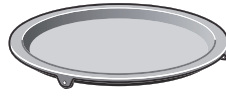

Metal tray turntable

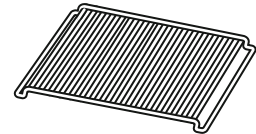

Wire rack

Ceramic microwave tray

Use for microwave cooking and conventional cooking. Food like a popcorn bag or potatoes can be directly placed on the ceramic tray.

Warning :

- The ceramic tray will get hot during convention cooking
- Place the ceramic tray on top of the metal tray turntable
- The ceramic tray can remain in the oven for all cooking modes, unless “Bake on Metal Tray” is required.
- Use ceramic tray on top of metal tray to pop popcorn.
- Do not pop popcorn directly on metal turntable tray.

Wire rack

Use the wire rack with recess facing down for Convection, Keep Warm and to fit larger dishes into the oven cavity. Use it facing up (as shown) for Broil/Grill.

Metal tray turntable with bake element below

Provide heat for food which particularly requires a lot of heat from underneath. Place the turntable with the rollers “A” as shown in the picture, on the carrier “B” in the middle of the cooking compartment floor. The turntable must sit straight on the carrier.

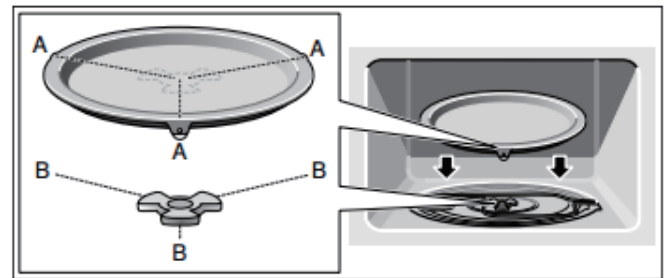

NOTE

Do not use the appliance if the turntable is not in place. Confirm that all parts are properly seated and that the turntable rotates freely when the microwave is operated. The metal tray turntable can support max. 12 lbs.

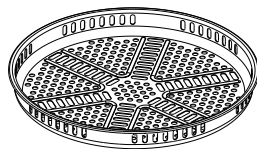

Air Fry Tray

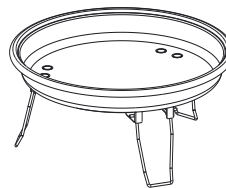

Air Fry Pan

➔ NOTE

The Round Wire Rack can be used for Convection cooking and Microwave Cooking functions.

➔ NOTE

The wire rack can be used for microwave cooking only.

⚠ CAUTION

The Air Fry Pan and Air Fry Tray are designed for Air Fry cooking only and should not be used for any other microwave cooking.

Always use oven mitts when handling hot items.

The preheated Air Fry Pan and Air Fry Tray will be hot.

➔ NOTE

Both Air Fry and Convection Cook use all the elements, and the convection fan. Convection is more gradual than Air Fry and is intended for baking and roasting.

Convection can be used for all kinds of foods, sometimes even more than one food at a time! Air Fry works differently than normal convection cooking. The convection element in Air Fry oven is more powerful as a standard convection element.

The oven control's program for Air Fry is specifically designed for fried foods. When you put your food in the oven, the hot air works the way hot oil does while frying: by completely surrounding the food with intense, flowing heat.



These differences allow Air Fry to make and circulate superheated air that's hotter sooner. Air Fry is intended for single rack cooking, so that hot air can circulate all around the food for the crunchiest results, especially when using our Air Fry Tray!

10 OPERATION

1. Before operating your new oven make sure you read and understand this Use and Care Guide completely.
2. Before the Built-in Convention Microwave Oven can be used, follow these procedures:
 - Plug in the oven. Close the door. The oven display will flash 12:00.
 - If no operation after 1 minute, the oven will show 12:01.
3. Set clock. See below.

TO SET THE CLOCK

Suppose you want to enter the correct time of day 12:30 (A.M or P.M.).

Touch	Display Shows:
1.  HOLD 3S FOR ON/OFF	12:00
2. 	12:30
3.  HOLD 3S FOR ON/OFF	12:30

NOTE



When clock is in set mode and after 3 seconds of no activity the clock will automatically set to the time in the display.

SETTING THE CLOCK ON/OFF

Clock display ON default.

1. Touch and hold pad.  HOLD 3S FOR ON/OFF
2. Time will display, after 3s, OFF will display. **OFF**

Clock Display OFF.

1. Clock key (short press <1sec) to enter the clock query state, display "current clock" for 3 seconds and then return to standby mode, the clock is not displayed;  HOLD 3S FOR ON/OFF
2. Hold Clock button 3s, display is OFF.  HOLD 3S FOR ON/OFF
3. When display is off, Tap (short press) will display time for 3 sec. **ON**

TO SET THE TIMER

Set the timer for 3 minutes.

Touch	Display Shows:
1. TIMER	0:00 MIN : SEC
2. 	3:00 MIN : SEC
3. TIMER	3:00 MIN : SEC Time counting down

NOTE

1. Opening the door during timer countdown will not pause the running timer.
2. To cancel the active timer, press the CANCEL key once.
3. Arrow button can be operated to set the time.

CANCEL

Press the CANCEL to:

1. Erase if you make a mistake during programming.
2. Cancel timer and the signal after cooking.
3. Cancel a program during cooking, press once.

CONTROL LOCK

You may lock the control panel to prevent the microwave from being accidentally started or used by children.

The control lock feature is very useful when cleaning the control panel. The lock will prevent accidental programming when wiping the control panel clean.

Example: to set the control lock ON:

Touch and hold the CANCEL pad for more than 3 seconds. The display will show LOCKED for 2 seconds.

CANCEL
HOLD 3S TO LOCK

Example: to change the control lock from ON to OFF:

Touch and hold the CANCEL pad for more than 3 seconds. The display will show UNLOCK for 2 seconds.

CANCEL
HOLD 3S TO LOCK

USING ONE TOUCH START

This is a time saving pad that will automatically start cooking 2 seconds after selected. Numeric key 1 to 9 can be touched for a 1 minute to 9 minutes automatic start cooking feature.

Suppose you want to cook 3 minutes at 100%power.

Touch	Display Shows:
1. 	<p>3:00</p> <p>MIN : SEC</p> <p>Time counting down automatically after 2 seconds</p>

USING ADD 30 SEC.

This is a time-saving pad. It is a simplified feature that lets you quickly set and start microwave cooking at 100% power.

Suppose you want to set and start microwave cooking at 100% for 30 SEC.

Touch	Display Shows:
1. +30 SEC	<p>30</p> <p>SEC</p> <p>Time counting down</p>

NOTE

1. The cooking time can be extended for 30 seconds by pressing add 30 sec key (only in manual cooking). The cooking time is extended to a maximum of 99 minutes 99 seconds.
2. Touch <> once to drop or add 5 seconds.
3. "FOOD" will be displayed if a quick start cooking cycle or +30 sec key is not selected within 5 minutes of placing food in the microwave. You must open then close the door again to clear "FOOD" from the display.

12 OPERATION

SETTING TIMED COOKING WITH POWER LEVEL

This feature lets you program a specific cook time and power. For best results, there are 11 power level settings in addition to HIGH (100%) power. Refer to the "Microwave Power Levels" table.

COOK POWER	LEVEL	WHEN TO USE IT
100% of full power	High	<ul style="list-style-type: none">• Quickly heating convenience foods and foods with high water content, such as soup and beverages.• Cooking tender cuts of meat, ground meat or chicken.
9 = 90% of full power		<ul style="list-style-type: none">• Heating cream soups.
8 = 80% of full power		<ul style="list-style-type: none">• Heating rice, pasta, or casseroles.
7 = 70% of full power	Medium-High	<ul style="list-style-type: none">• Cooking and heating foods that need a Cook Power lower than High (for example, whole fish and meat loaf) or when food is cooking too fast.• Reheating a single serving of food.
6 = 60% of full power		<ul style="list-style-type: none">• Cooking that requires special care, such as cheese and egg dishes, pudding, and custards.• Finishing cooking casseroles.
5 = 50% of full power	Medium	<ul style="list-style-type: none">• Cooking ham, whole poultry, and pot roasts.• simmering stews.
4 = 40% of full power		<ul style="list-style-type: none">• Melting chocolate.• Heating pastries.
3 = 30% of full power	Medium-Low, Defrost	<ul style="list-style-type: none">• Manually defrosting pre-cooked and other foods, such as bread, fish, meats and poultry.
2 = 20% of full power		<ul style="list-style-type: none">• softening butter, cheese, and ice cream.
1 = 10% of full power	Low	<ul style="list-style-type: none">• Keeping food warm.• Taking chill out of fruit.
0 = 0% of full power	None	<ul style="list-style-type: none">• Standing time in oven.

Suppose you want to cook for five minutes at 70% power.

Touch	Display Shows:
1. 5 0 0	5:00 MIN : SEC
2. POWER LEVEL	PWR 100%
3. 7	PWR 70%
4. OK/START	5:00 MIN : SEC Time counting down

NOTE

If you do not select a power level, the oven will automatically cook at HIGH (100%) power.

SETTING TWO-STAGE COOKING

For best results, some recipes call for different power levels during a cook cycle. You can program your oven for two power level stages during the cooking cycle.

To set a 2-stage cook cycle. The first stage is a 2 minutes cook time at 30% cook power then a 4 minutes cook time at 70% cook power.

Touch	Display Shows:
1. 2 0 0	2:00 MIN : SEC
2. POWER LEVEL	PWR 100%
3. 3	PWR 30%
4. POWER LEVEL	" ENTER STAGE 2 POWER PRESS OK "
5. 7	PWR 70%
6. OK/START	" ENTER STAGE 2 COOK TIME PRESS START "
7. 4 0 0	4:00 MIN : SEC
8. OK/START	2:00 MIN : SEC Time counting down

When the first stage finishes, the oven will beep. "FIRST STAGE DONE" will show on the display. The second stage starts automatically.

14 OPERATION

CONVECTION BAKE

Suppose you want to bake 33 min at 375 degree.

Touch	Display Shows:
1. CONV COOK	BAKE
2. OK/START	325°
3. (7)	375°
4. OK/START	0:00 MIN : SEC
5. (3) (3) (0) (0)	33:00 MIN : SEC
6. OK/START	BAKE 375° then time counting down

Bake (Deg F)	Key
250	3
300	4
325(Default)	5
350	6
375	7
400	8
425	9

CONVECTION ROAST

Suppose you want to roast 33 min at 375 degree.

Touch	Display Shows:
1. CONV COOK	BAKE
2. CONV COOK	ROAST
3. OK/START	350°
4. (7)	375°
5. OK/START	0:00 MIN : SEC
6. (3) (3) (0) (0)	33:00 MIN : SEC
7. OK/START	ROAST 375° then time counting down

Roast (Deg F)	Key
300	4
325	5
350(Default)	6
375	7
400	8
425	9

TIPS FOR CONVECTION COOKING

This section gives you cooking instructions and procedures for operating each convection function. Please read these instructions carefully. Convection cooking circulates hot air through the oven cavity with a fan. The constantly moving air surrounds the food to heat the outer portion quickly, creating even browning and sealed-in flavor by the constant motion of hot air over the food surfaces. Your oven uses convection cooking whenever you use the Convection Button. **DO NOT USE THE OVEN WITHOUT THE TURNTABLE IN PLACE.**

1. **Do not cover** turntable or metal rack with aluminum foil. It interferes with the flow of air that cooks the food.
2. **Round pizza pans** are excellent cooking utensils for many convection-only items. Choose pans that do not have extended handles.
3. **Use convection cooking** for items like souffles, breads, cookies, angel food cakes, pizza, and for some meat and fish.
4. **You do not need to use** any special techniques to adapt your favorite oven recipes to convection cooking; however, you need to lower oven temperature by 25°F from recommended temperature mentioned in package instructions when cooking packaged food in convection mode.
5. **When baking** cakes, cookies, breads, rolls, or other baked foods, most recipes call for preheating. Preheat the empty oven just as you do a regular oven. You can start heavier dense foods such as meats, casseroles, and poultry without preheating.
6. **All heat-proof** cookware or metal utensils can be used in convection cooking.
7. **Use metal utensils** only for convection cooking. Never use for microwave or combination cooking since arcing and damage to the oven may occur.
8. **After preheating**, if you do not open the door, the oven will automatically hold at the preheated temperature for 30 minutes.

PRECAUTIONS

- The oven cavity, door, metal turntable tray, ceramic tray, metal rack, and cooking utensils will become very hot. **USE THICK OVEN GLOVES** when removing the food, cooking utensils, metal turntable tray, ceramic tray, metal rack from the oven after convection cooking.
- Do not use lightweight plastic containers, plastic wraps, or paper products during any convection.

CONVECTION Broil/Grill COOKING

The broil / grill touch pad lets you broil at a high or low setting and also cook fresh and frozen pizza. See table below.

Suppose you want to broil or grill for 20 minutes with the low level.

Touch	Display Shows:
1. CONV COOK x3	BROIL HIGH
2. CONV COOK	BROIL LOW
3. OK/START	0:00 MIN : SEC
4. 2 0 0 0	20:00 MIN : SEC
5. OK/START	20:00 MIN : SEC

Time counting down

KEY PRESS	Food
CONV COOK x1	Bake
CONV COOK x2	Roast
CONV COOK x3	Broil high
CONV COOKx4	Broil low

Pizza tips

- For fresh pizza use a pizza paddle for sliding the pizza on and from the metal turntable.
- If using a pizza paddle, sprinkle the paddle liberally with cornmeal for ease in transferring the dough to the metal turntable.
- Maximum size is 12 inches for fresh and frozen pizzas.
- Avoid using a pizza stone as it can damage the oven.
- The metal turntable can be used for cutting pizza into slices. Remove the turntable from the oven after the pizza is baked.

16 OPERATION

PREHEAT

Suppose you want to preheat 350 degree.

Touch	Display Shows:
1. KEEP WARM	PREHEAT
2. OK/START	325°
3. 6	350°
4. OK/START	PREHEAT
When set preheat temp is reached.	OVEN READY

KEEP WARM

Suppose you want to keep warm for 33min.

Touch	Display Shows:
1. KEEP WARM	PREHEAT
2. KEEP WARM	WARM
3. OK/START	0:00 MIN : SEC
4. >	33:00
5. OK/START	WARM

NOTE

The temperature range has 9 steps from 100F° to 425 °F.

Preheat (Deg F)	Key
100	1
200	2
250	3
300	4
325 (Default)	5
350	6
375	7
400	8
425	9

NOTE

If you do not set a keep warm time, just press Convection Keep Warm then touch OK/START, you can keep warm up to 90 minutes.

- The keep warm function will work at 170°F and it can not be changed.

Air Fry

The Air Fry feature works best when using the Air Fry Pan and Air Fry Tray with packaged and convenience foods and can be programmed for temperatures between 100°F and 425°F using preset temperatures.

Follow the recipe or package directions for food preparation quantity, time, and temperature.

Important:

- Air Fry is designed for baking on a single oven rack. Food should be arranged in single layers on the Air Fry Tray.
- Place Air Fry Pan on ceramic tray to preheat.
- Food may need to be removed early and should be checked at minimum recommended bake time. However, frozen dense foods and items with cook times less than 15 minutes may require additional time.
- Suppose you want to Air Fry at 425°F for 19 minutes.

Touch:

Display Shows:

- | | |
|-----------------------------------------------------------------------|-------------------|
| 1. AIR FRY | AIRFRY ENTER TEMP |
| 2. (9) | 425° |
| 3. OK/START | ENTER TIME |
| 4. (1)(9)(0)(0) | 19:00 |
| 5. OK/START | PREHEAT |
| 6. Oven temperature is reached. | ADD FOOD |
| 7. Open the door and then put the food into the oven. Close the door. | |
| 8. Touch OK/START to start cooking. | 19:00 |
- Time counting down

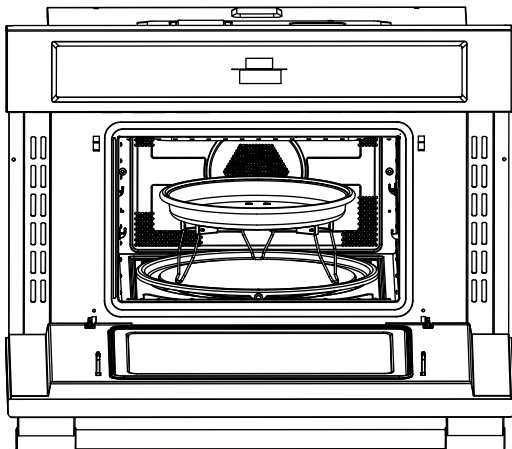

NOTE

Preheat the Air Fry Pan with the legs extended and place on the ceramic tray which is on the metal turntable. Do not place the Air Fry Pan legs on the metal turntable.



Touch the +10 SEC or +30 SEC to add time during time countdown. Adding time will not work during preheating.



When oven is preheated it will beep and the display will show ADD FOOD. Place the Air Fry Tray with food into the Air Fry Pan.



When cooking is finished, the oven will beep to notice removing food and the display will show COOLING.



The Air Fry pan, and tray have been designed together and most food do not require flipping during cooking.



When you Air Fry whole chicken, fold the Air Fry pan legs down and place on the ceramic tray.

CAUTION

The preheated Air Fry collapsible pan will be hot when placing the tray with food into the oven.

WARNING

Should an oven fire occur, close the oven door and turn the oven off. If the fire continues, use a fire extinguisher. Do not put water or flour on the fire.

18 OPERATION

SETTING POPCORN

The Popcorn quick touch pad lets you pop 3.3, 3.0, 1.75 ounce bags of commercially packaged microwave popcorn. Pop only one package at a time. If you are using a microwave popcorn popper, follow manufacturer's instructions.

Suppose you want to pop a 3.3 oz. popcorn

Touch	Display Shows:
1. POPCORN	3.3 07
2. OK/START	POPCORN Then time will count down

Key press	Selection	Amount
Popcorn	3.3	3.3 oz (94g)
Popcorn	3.0	3.0 oz (85g)
Popcorn	1.75	1.75 oz (50g)

NOTE

1. Remove wire rack from oven before cooking popcorn. Do not use regular paper bags. Do not re-pop un-popped kernels. Do not pop popcorn in glass cookware.
2. Use ceramic tray on top of metal tray to pop popcorn.
3. Do not pop popcorn directly on metal turntable tray.
4. Do not leave microwave oven unattended while popping corn.

SENSOR OPERATING INSTRUCTIONS

Sensor Cook allows you to cook most of your favorite foods without selecting cooking times and power levels. The display will show the selected food type during the initial sensing period. The oven automatically determines required cooking time for each food item. When the internal sensor detects a certain amount of humidity coming from the food, it will tell the oven how much longer to heat. The display will show the remaining heating time. For best results for cooking by Sensor, follow these recommendations.

1. Food cooked with the sensor system should be at normal storage temperature.
2. Always use microwavable containers.
3. Match the amount to the size of the container. Fill containers at least half full for best results.
4. Be sure the outside of the cooking container and the inside of the microwave oven are dry before placing food in the oven. Beads of moisture turning into steam can mislead the sensor.
5. Foods should always be covered with microwavable plastic wrap, waxed paper, or a lid. Never use tightsealing plastic covers. They can prevent steam from escaping and cause food to overcook.
6. Do not open the door or touch the CANCEL key during the sensing time. When sensing time is over, the oven beeps and the remaining cooking time will appear in the display window. At this time you can open the door to stir, turn, or rearrange the food.

USING SENSOR COOK

Using SENSOR COOK lets you cook common microwave-prepared foods without needing to program times and cook powers.

Suppose you want to cook fish seafood with sensor.

	Touch	Display Shows:
1.	SENSOR COOK	BACON
2.	SENSOR COOK	FROZEN ENTREE
3.	SENSOR COOK	WHITE RICE
4.	SENSOR COOK	GROUND MEAT
5.	SENSOR COOK	FISH/SEAFOOD
6.	OK/START	FISH/SEAFOOD

Sensor Cook selections are made by touching the Sensor Cook key multiple times.

USING SENSOR REHEAT

Using SENSOR REHEAT lets you reheat common microwave-prepared foods without selecting cooking times and power levels.

Suppose you want to reheat soup sauce.

	Touch	Display Shows:
1.	SENSOR REHEAT	BEVERAGE
2.	SENSOR REHEAT	SOUP SAUCE
3.	OK/START	SOUP SAUCE

Sensor Reheat selections are made by touching the Sensor Reheat key multiple times.

20 OPERATION

SENSOR COOK TABLE

Display	Food	The Number Key	Weight
BACON	Bacon	1	1 slice
		2	2 slices
		3	3 slices
FROZEN ENTREE	Frozen entree	-	10 oz/20 oz
WHITE RICE	White rice	-	2-5 cups
GROUND MEAT	Ground meat	-	8-24 oz
FISH/SEA FOOD	Fish/Sea food	-	8-20 oz
POTATO	Potato	-	1-4
FRESH VEGGIES	Fresh vegetables	-	1- 4 cups
FROZEN VEGGIES	Frozen vegetables	-	1- 4 cups

Note

• For the menu "BACON", after touching SENSOR COOK to select bacon function, touch the corresponding number key or touch < or > to set the weight of the food, and then touch OK/START to start cooking.

SENSOR REHEAT TABLE

Display	Food	The Number Key	Weight
BEVERAGE	Beverage	1	1 cup (8oz)
		2	2 cups (16 oz)
		3	3 cups (24 oz)
SOUP SAUCE	Soup sauce	-	1 - 2 cups
PIZZA	Pizza	-	1 - 4 slices
DINNER PLATE	Dinner plate	-	1 plate
CASSEROLE/PASTA	Casserole/pasta	-	1 serving

Note

• For the menu "BEVERAGE", after touching SENSOR REHEAT to select beverage function, touch the corresponding number key or touch < or > to set the weight of the food, and then touch OK/START to start cooking.

SETTING MELT/SOFTEN

The oven uses low power to melt and soften items. See the following table.

Suppose you want to melt 8 oz. of Chocolate.

- | Touch | Display Shows: |
|--------------------|----------------|
| 1. MELT/
SOFTEN | MELT BUTTER |
| 2. MELT/
SOFTEN | MELT CHOCOLATE |
| 3. OK/START | 2 07 |
| 4. 8 | 8 07 |
| 5. OK/START | MELT CHOCOLATE |
- then time will count down

KEY	Food	Amount	KEY
Melt / Soften x1	Melt Butter	1 stick	1
		2 sticks	2
Melt / Soften x2	Melt Chocolate	2 oz.	2
		4 oz.	4
		8 oz.	8
Melt / Soften x3	Soften Ice Cream	1 Pint	1
		1/2 gallons	2
Melt / Soften x4	Soften Cream Cheese	3 oz.	3
		8 oz.	8

22 OPERATION

USING AUTO DEFROST

Three defrost sequences are preset in the oven. The auto defrost feature provides you with the best defrosting method for frozen foods.

The cooking guide will show you which defrost sequence is recommended for the food you are defrosting.

For added convenience, the Auto Defrost includes a built in beep mechanism that reminds you to check, turn over, separate, or rearrange the food in order to get the best defrost results. Three different defrosting levels are provided:

1. MEAT
2. POULTRY
3. FISH

Available weight is 0.1-6.0 lbs.

Suppose you want to defrost 0.6 lbs of meat.

Touch	Display Shows:
1. DEFROST	MEAT
2. OK/START	0.0 LB
3. 	0.6 LB
4. OK/START	MEAT

Then time will count down

NOTE

The oven will beep during the DEFROST cycle. At this time, open the door and turn, separate, or rearrange the food. Remove any portions that have thawed. Return frozen portions to the oven and touch OK/START to resume the defrost cycle.

This table shows food type selections and the weights you can set for each type. For best results, loosen or remove covering on food.

KEY PRESS	Category	WEIGHTS YOU CAN SET (tenths of a pound)
Defrost	Meat	0.1 to 6.0
Defrost	Poultry	0.1 to 6.0
Defrost	Fish	0.1 to 6.0

OPERATING TIPS

- For best results, remove fish, shellfish, meat, and poultry from its original closed paper or plastic package (wrapper). Otherwise, the wrap will hold steam and juice close to the foods, which can cause the outer surface of the foods to cook.
- For best results, roll your ground meat into a ball before freezing. During the DEFROST cycle, the microwave will signal when it is time to turn the meat over. Scrape off any excess frost from the meat and continue defrosting.
- Place foods in a shallow containers or on a microwave roasting rack to catch drippings.

DEFROSTING TIPS





- When using Auto Defrost, the weight to be entered is the net weight (the weight of the food minus the container).
- Before starting, make sure to remove any and all metal twist-ties that often come with frozen food bags, and replace them with strings or elastic bands.
- Open containers, such as cartons, before placing in the oven.
- Always slit or pierce plastic pouches or packaging.
- If food is foil wrapped, remove foil and place food in a suitable container.
- Slit the skin of skinned food, such as sausage.
- Bend plastic pouches of food to ensure even defrosting. Always under estimate defrosting time. If defrosted food is still icy in the center, return it to the microwave oven for more defrosting.
- The length of defrosting time varies according to how solidly the food is frozen.
- The shape of the package affects how quickly food will defrost. Shallow packages will defrost more quickly than a deep block.
- As food begins to defrost, separate the pieces. Separated pieces defrost more easily.
- Use small pieces of aluminum foil to shield parts of food such as chicken wings, leg tips, fish tails, or areas that start to get warm. Make sure the foil does not touch the sides, top, or bottom of the oven. The foil can damage the oven lining.
- For better results, let food stand after defrosting. (For more information on standing time, see the "Microwave Cooking Tips" section).
- Turn over food during defrosting or standing time. Break apart and remove food as required.

USER REFERENCE

This section gives instructions for operating each function. Please read this section carefully.

USER PREF

The microwave oven has settings that allow you to customize the operation for your convenience. Below is the table showing the various settings. Touch the User Pref key multiple times to scroll to the desired setting function.

Key	Food	Level
 x 1	Audio	Low / Med / High / OFF
 x 2	Weight	Lbs / KG
 x 3	Language	English / French
 x 4	Demo Mode	ON / OFF

SETTING AUDIO LOW/MED/HIGH/OFF

Suppose you want to turn on the Audio Off.



Touch	Display Shows:
1. 	AUDIO
2. OK/START	MED
3. >	HI
4. >	OFF
5. OK/START	OFF

Display for 2 seconds then clear.

24 OPERATION

SETTING WEIGHT LBS/KG

Suppose you want to toggle weight between pounds & kilograms.

Touch	Display Shows:
1. 	AUDIO
2. 	WEIGHT
3. OK/START	LBS
4. >	KG
5. OK/START	KG

Display for 2 seconds then clear.

SETTING LANGUAGE MODE

Suppose you want to enter Language Mode.

Touch	Display Shows:
1. 	AUDIO
2. 	WEIGHT
3. 	LANGUAGE
4. OK/START	ENGLISH
5. >	FRENCH
6. OK/START	FRANCAIS

Display for 2 seconds then clear.

SETTING DEMO MODE

Suppose you want to enter Demo Mode. When Demo mode is ON programming functions will work in a rapid countdown mode with no cooking power.

Touch	Display Shows:
1. 	AUDIO
2. 	WEIGHT
3. 	LANGUAGE
4. 	DEMO
5. OK/START	OFF
6. 	ON
7. OK/START	ON

Display for 2 seconds then clear.

26 MAINTENANCE

Troubleshooting

Check your problem by using the chart below and try the solutions for each problem. If the microwave oven still does not work properly, contact the nearest authorized service center.

TROUBLE	POSSIBLE CAUSE	POSSIBLE REMEDY
Oven will not start	<ul style="list-style-type: none">• Electrical cord for oven is not plugged in.• Door is open.• Wrong operation is set.	<ul style="list-style-type: none">• Plug into the outlet.• Close the door and try again.• Check instructions.
Arcing or sparking	<ul style="list-style-type: none">• Materials to be avoided in microwave oven were used.• The oven is operated when empty.• Spilled food remains in the cavity.	<ul style="list-style-type: none">• Use microwave-safe cookware only.• Do not operate with oven empty.• Clean cavity with wet towel.
Unevenly cooked foods	<ul style="list-style-type: none">• Materials to be avoided in microwave oven were used.• Food is not defrosted completely.• Cooking time, power level is not suitable.• Food is not turned or stirred.	<ul style="list-style-type: none">• Use microwave-safe cookware only.• Completely defrost food.• Use correct cooking time, power level.• Turn or stir food.
Overcooked foods	<ul style="list-style-type: none">• Cooking time, power level is not suitable.	<ul style="list-style-type: none">• Use correct cooking time, power level.
Undercooked foods	<ul style="list-style-type: none">• Materials to be avoided in microwave oven were used.• Food is not defrosted completely.• Oven ventilation ports are restricted.• Cooking time, power level is not suitable.	<ul style="list-style-type: none">• Use microwave-safe cookware only.• Completely defrost food.• Check to see that oven ventilation ports are not restricted.• Use correct cooking time, power level.
Improper defrosting	<ul style="list-style-type: none">• Materials to be avoided in microwave oven were used.• Cooking time, power level is not suitable.• Food is not turned or stirred.	<ul style="list-style-type: none">• Use microwave-safe cookware only.• Use correct cooking time, power level.• Turn or stir food.

Disconnect the power cord before cleaning or leave the door open to deactivate the oven during cleaning.

EXTERIOR

The outside surface is precoated steel and plastic. Clean the outside with mild soap and water; rinse and dry with a soft cloth. Do not use any type of household or abrasive cleaner.

DOOR

Disconnect the power cord or deactivate the oven with setting Child Lock before cleaning to prevent unexpected manipulation.

Wipe the window on both sides with a soft cloth to remove any spills or splatters. Metal parts will be easier to maintain if wiped frequently with a soft cloth. Avoid the use of spray and other harsh cleaners as they may stain, streak or dull the door surface.

EASY CARE™ STAINLESS STEEL / SMUDGE _PROOF™ STAINLESS STEEL /BLACK STAINLESS STEEL(SOME MODELS)

Your microwave oven(some models) may have a Stainless Steel finish or coating. Clean the stainless with warm soapy water using a clean sponge or cloth. Rinse with clean water and dry with a soft clean cloth. DO NOT use ANY store bought cleaners like Stainless Steel cleaners or any other types of cleaners containing any abrasive, chlorides, chlorines or ammonia. It is recommended to use mild dish soap and water or a 50/50 solution of water and vinegar.

INTERIOR

Cleaning is easy because little heat is generated to the interior surfaces; therefore, there is no baking and setting of spills or spattering. To clean the interior surfaces, wipe with a soft cloth and warm water. DO NOT USE ABRASIVE OR HARSH CLEANERS OR SCOURING PADS. For heavier soil, use baking soda or a mild soap; rinse thoroughly with hot water. The rack can be cleaned with hot soapy water, rinsed and dried.

WAVEGUIDE COVER

The waveguide cover is located on the ceiling in the microwave oven cavity. It is made from mica so requires special care. Keep the waveguide cover clean to assure good microwave oven performance. Carefully wipe with a damp cloth any food splatters from the surface of the cover immediately after they occur. Built-up splashes may overheat and cause smoke or possibly catch fire. DO NOT REMOVE THE WAVEGUIDE COVER.

ODOR REMOVAL

Occasionally, a cooking odor may remain in the microwave oven. To remove, combine 1 cup water, grated peel and juice of 1 lemon and several whole cloves in a 2-cup glass measuring cup. Boil for several minutes using 100% power. Allow to set in microwave oven until cool. Wipe interior with a soft cloth.

METAL TURNTABLE TRAY AND CERAMIC TRAY;

The metal turntable tray and ceramic tray can be removed for easy cleaning. Wash them in mild, sudsy water. They are also dishwasher-proof. Use upper rack of dishwasher. The turntable motor shaft is not sealed, so excess water or spills should be wiped up immediately.

TOUCH CONTROL PANEL

Care should be taken in cleaning the touch control panel. If the control panel becomes soiled, open the microwave oven door before cleaning. Wipe the panel with a cloth dampened slightly with water only. Dry with a soft cloth. Do not scrub or use any sort of chemical cleaners.

28 SERVICE CALL CHECK

Please check the following before calling for service:

Place one cup of water in a glass measuring cup in the microwave oven and close the door securely. Operate the microwave oven for one minute at HIGH 100%.

- | | |
|--------------------------------------------------------------------------------------------|------------------|
| A Does the microwave oven light come on? | YES ____ NO ____ |
| B Does the cooling fan work? (Put your hand at top above Display.) | YES ____ NO ____ |
| C Does the turntable rotate? (It is normal for the turntable to turn in either direction.) | YES ____ NO ____ |
| D Is the water in the microwave oven warm? | YES ____ NO ____ |

If “NO” is the answer to any of the above questions, please check electrical outlet, fuse and/or circuit breaker. If they are functioning properly, CONTACT YOUR NEAREST ELECTROLUX AUTHORIZED SERVICER.

A microwave oven should never be serviced by a “do-it-yourself” repair person.

NOTE

1. After starting the microwave function, if it does not heat, check whether it is DEMO mode.

SPECIFICATIONS

AC Line Voltage:	Single phase 120VAC, 60Hz, AC only
AC Power Required::	1750W 20A
Output Power*:	1000 W
Input Power*(Airfry):	1750 W
Input Power*(convection):	1700 W
Frequency:	2450 MHz(Class B/Group2)**
Outside Dimensions (including handle):	19.08" X 29.88"X 25.44"
Cavity Dimensions:	9.84" X 16.54"X 16.54"
Microwave oven Capacity***:	1.6 Cu.Ft.
Cooking Uniformity:	Turntable
Weight:	Approx. (net) 90.7 lbs , (gross) 105.8lbs
Oven Light:	1.5W LED

* The International Electrotechnical Commission’s standardized method for measuring output wattage. method is widely recognized. test method

** This is the classification of ISM (Industrial, Scientific and Medical) equipment described in the International Standard CISPR11.

*** Internal capacity is calculated by measuring maximum width, depth and height. Actual capacity for holding food is less. In compliance with standards set by:

FCC - Federal Communications Commission Authorized.

DHHS - Complies with Department of Health and Human Services (DHHS) rule, CFR, Title 21, Chapter I, Subchapter J.



- This symbol on the nameplate means the product is listed by Underwriters Laboratories, Inc.



- This symbol on the nameplate means the product is listed by Underwriters Laboratories, Inc. for use in USA or Canada.

Your appliance is covered by a one year limited warranty. For one year from your original date of purchase, Electrolux will pay all costs for repairing or replacing any parts of this appliance that prove to be defective in materials or workmanship when such appliance is installed, used and maintained in accordance with the provided instructions.

Exclusions

This warranty does not cover the following:

1. Products with original serial numbers that have been removed, altered or cannot be readily determined.
2. Product that has been transferred from its original owner to another party or removed outside the USA or Canada.
3. Rust on the interior or exterior of the unit.
4. Products purchased "as-is" are not covered by this warranty.
5. Food loss due to any refrigerator or freezer failures.
6. Products used in a commercial setting.
7. Service calls which do not involve malfunction or defects in materials or workmanship, or for appliances not in ordinary household use or used other than in accordance with the provided instructions.
8. Service calls to correct the installation of your appliance or to instruct you how to use your appliance.
9. Expenses for making the appliance accessible for servicing, such as removal of trim, cupboards, shelves, etc., which are not a part of the appliance when it is shipped from the factory.
10. Service calls to repair or replace appliance light bulbs, air filters, water filters, other consumables, or knobs, handles, or other cosmetic parts.
11. Surcharges including, but not limited to, any after hour, weekend, or holiday service calls, tolls, ferry trip charges, or mileage expense for service calls to remote areas, including the state of Alaska.
12. Damages to the finish of appliance or home incurred during installation, including but not limited to floors, cabinets, walls, etc.
13. Damages caused by: services performed by unauthorized service companies; use of parts other than genuine Electrolux parts or parts obtained from persons other than authorized service companies; or external causes such as abuse, misuse, inadequate power supply, accidents, fires, or acts of God.
14. Labor costs after ninety (90) days from your original date of purchase incurred for product repair or replacement as provided herein for carry-in appliances.

DISCLAIMER OF IMPLIED WARRANTIES; LIMITATION OF REMEDIES

CUSTOMER'S SOLE AND EXCLUSIVE REMEDY UNDER THIS LIMITED WARRANTY SHALL BE PRODUCT REPAIR OR REPLACEMENT AS PROVIDED HEREIN. CLAIMS BASED ON IMPLIED WARRANTIES, INCLUDING WARRANTIES OF MERCHANTABILITY OR FITNESS FOR A PARTICULAR PURPOSE, ARE LIMITED TO ONE YEAR OR THE SHORTEST PERIOD ALLOWED BY LAW, BUT NOT LESS THAN ONE YEAR. ELECTROLUX SHALL NOT BE LIABLE FOR CONSEQUENTIAL OR INCIDENTAL DAMAGES SUCH AS PROPERTY DAMAGE AND INCIDENTAL EXPENSES RESULTING FROM ANY BREACH OF THIS WRITTEN LIMITED WARRANTY OR ANY IMPLIED WARRANTY. SOME STATES AND PROVINCES DO NOT ALLOW THE EXCLUSION OR LIMITATION OF INCIDENTAL OR CONSEQUENTIAL DAMAGES, OR LIMITATIONS ON THE DURATION OF IMPLIED WARRANTIES, SO THESE LIMITATIONS OR EXCLUSIONS MAY NOT APPLY TO YOU. THIS WRITTEN WARRANTY GIVES YOU SPECIFIC LEGAL RIGHTS. YOU MAY ALSO HAVE OTHER RIGHTS THAT VARY FROM STATE TO STATE.

If You Need Service

Keep your receipt, delivery slip, or some other appropriate payment record to establish the warranty period should service be required. If service is performed, it is in your best interest to obtain and keep all receipts. Service under this warranty must be obtained by contacting Electrolux at the addresses or phone numbers below.

This warranty only applies in the USA and Canada. In the USA, your appliance is warranted by Electrolux Major Appliances North America, a division of Electrolux Home Products, Inc. In Canada, your appliance is warranted by Electrolux Canada Corp. Electrolux authorizes no person to change or add to any obligations under this warranty. Obligations for service and parts under this warranty must be performed by Electrolux or an authorized service company. Product features or specifications as described or illustrated are subject to change without notice.

USA

1-800-374-4432

Electrolux Home Products,
Inc., 10200 David Taylor
Drive Charlotte, NC 28262



Electrolux

Canada

1.800.265.8352

Electrolux Canada Corp.
5855 Terry Fox Way
Mississauga, Ontario, Canada

L5V 3E4

Printed in China

FRIGIDAIRE®

welcome *home*

Our home is your home. Visit us if you need help with any of these things:



owner support



accessories



service



registration

(See your registration card for more information.)

Frigidaire.com
1-800-374-4432

Frigidaire.ca
1-800-265-8352