

Save This Manual
For Future Reference

SEARS owner's manual

MODEL NO.
113.235200
COMPOUND MITER SAW

MODEL NO.
113.235100
NON-COMPOUND MITER
SAW

Serial
Number _____

Model and serial number
may be found on a plate
attached to your saw, at
the side of the Miter Saw
arm.

You should record both
model and serial number in
a safe place for future use.

FOR YOUR SAFETY:

**READ ALL
INSTRUCTIONS
CAREFULLY**

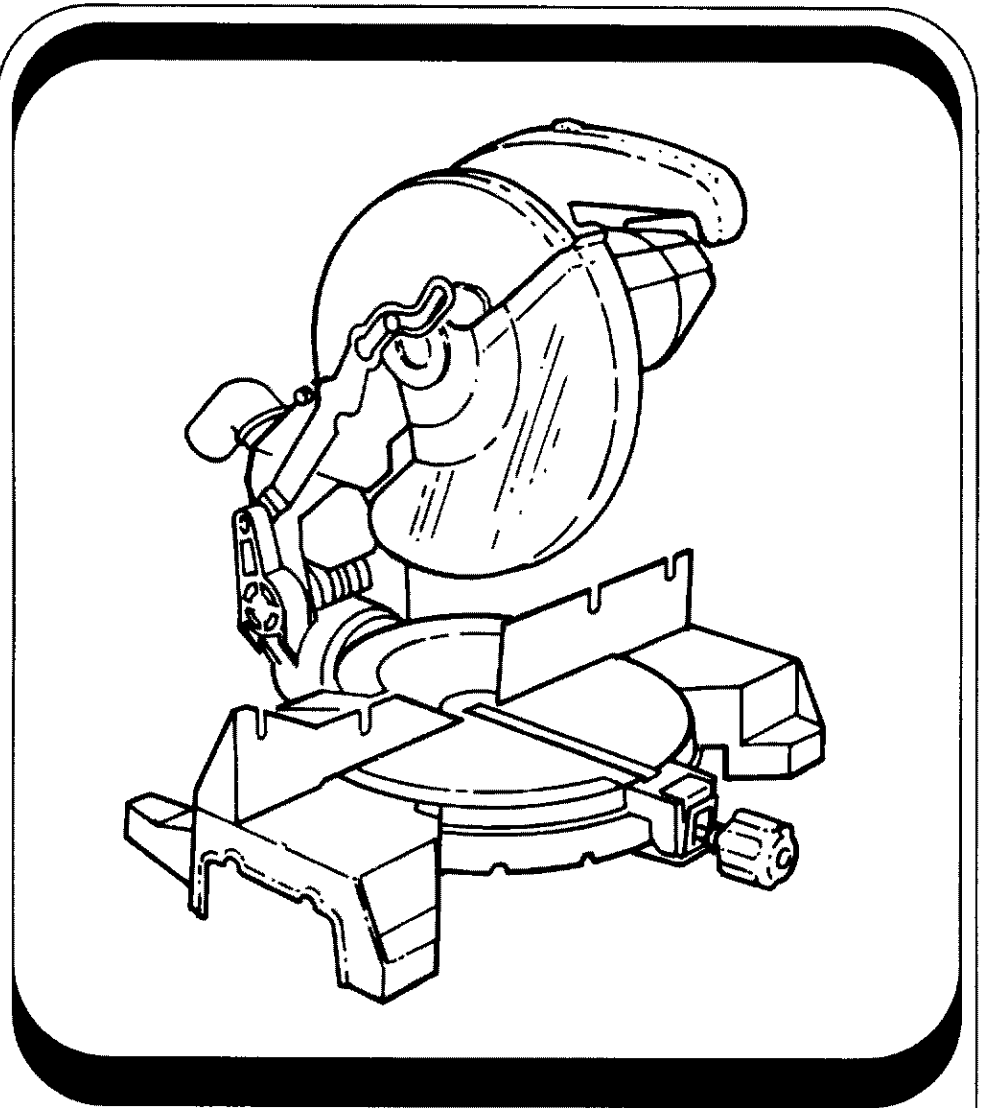

SEARS / CRAFTSMAN

10 INCH MITER SAW

- assembly
- operating
- repair parts

Sears, Roebuck and Co., Hoffman Estates, IL 60179 U.S.A.

FULL ONE YEAR WARRANTY ON CRAFTSMAN MITER SAW

If within one year from the date of purchase, this Craftsman Miter Saw fails due to a defect in material or workmanship, Sears will repair it, free of charge.

Warranty service is available by simply contacting the nearest Sears service center/department throughout the United States.

This warranty applies only while this product is used in the United States.

This warranty gives you specific legal rights, and you may also have other rights which vary from state to state.

Sears, Roebuck and Co., D/817 WA Hoffman Estates, IL 60179

Safety Instructions for Miter Saw

Safety is a combination of common sense, staying alert and knowing how your miter saw works. Read this manual to understand this miter saw.

SAFETY SIGNAL WORDS

⚠ DANGER: If the safety information is not followed, someone **Will** be seriously injured or killed.

⚠ WARNING: If the safety information is not followed, someone **Could** be seriously injured or killed.

⚠ CAUTION: If the safety information is not followed, someone **May** be injured.

Before Using The Saw:

WARNING: To avoid mistakes that could cause serious, permanent injury, do not plug the miter saw in until the following steps have been satisfactorily completed.

- Completely assemble and align saw. (See "Assembly" and "Alignment" sections within).
- Learn the use and function of the trigger switch, upper and lower blade guards, stop shaft, bevel lock knob (Model 113.235200 only) and cover plate stop screw (see "Getting to Know your Miter Saw" section within.)
- Review and understand all safety instructions and operating procedures in this manual.
- Review the maintenance methods for this miter saw. (See "Maintenance" section within).
- Find and Read the following labels on the miter saw:

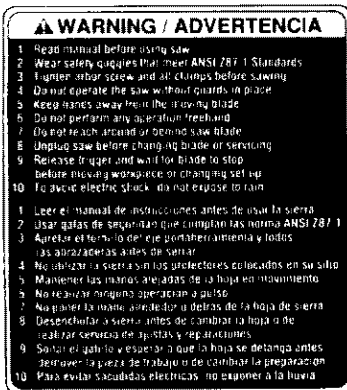

When Installing Or Moving The Miter Saw:

- Before moving the saw, lock the miter, bevel and power head positions. Unplug the power cord.
- To avoid back injury, get help when you need to lift the saw.
- **Never** carry the tool by the cord or power head switch handle. Damage to insulation could cause an electric shock. Damage to wire connections could cause a fire. A carry handle is provided.

Avoid Dangerous Environment.

- Use the miter saw in a dry, indoor place protected from rain.
- Keep work area well lighted.
- Place the saw so neither the user nor bystanders are forced to stand in line with the blade. Thrown debris could injure people in its path.

To avoid injury from unexpected saw movement:

- Put the miter saw on a firm level surface where there is plenty of room for handling and properly supporting the workpiece.
- Support the miter saw so the table is level and the saw does not rock.
- Bolt or clamp the miter saw to its support.
- **Never Stand On Tool.** Serious injury could occur if the tool tips or you accidentally hit the cutting tool. Do not store anything above or near the tool where anyone might stand on the tool to reach them.

To avoid injury or death from electrical shock:

- **This Tool Is Double Insulated** to give you added protection. Double insulation does not take the place or normal safety precautions when operating this tool. When servicing this double insulated tool, use only identical parts.
- Make sure your fingers do not touch the plug's metal prongs when plugging or unplugging the miter saw.

Before Each Use:

Inspect your miter saw.

- **Disconnect The Miter Saw** to avoid injury from accidental starting before changing the setup, changing the blade or adjusting anything.
- Compare the direction of rotation arrow on the guard to the direction arrow on the blade. The blade teeth should always point downward at the front of the saw.
- Tighten the arbor screw.
- Tighten the cover plate stop screw.

Check For Damaged Parts. Check for:

- Proper alignment of moving parts,
- Damaged electric cords,
- Binding of moving parts,
- Broken parts,
- Stable mounting,
- Function of arm return spring and lower guard: Push the arm all the way down, then let it rise up until it stops by itself. Check the lower guard to see if it closed fully. If it did not, follow the instructions in the "Trouble Shooting" section.
- Other conditions that may affect the way the miter saw works.

If any part of this miter saw is missing, bent, or broken in any way, or any electrical parts don't work, turn the saw off and unplug it. Replace damaged, missing, or failed parts before using the saw again.

Keep Guards In Place, in working order, and in proper adjustment.

Maintain Tools With Care. Keep the miter saw clean for best and safest performance. Follow instructions for lubricating. **DON'T** put lubricants on the blade while it's spinning.

Remove Adjusting Wrench and return it to proper storage location on tool.

To avoid injury from jams, slips or thrown pieces:

- **Use Only Recommended Accessories.** (See "Accessory" section within). Consult this Owner's manual for recommended accessories. Follow the instructions that come with the accessories. The use of improper accessories may cause risk of injury to persons.
- Choose the right 10-inch diameter blade for the material and the type of cutting you plan to do.
- Make sure the blade is sharp, undamaged and properly aligned. With the saw unplugged, push the power-head all the way down. Hand spin the blade and check for clearance. Tilt the power-head to 45 degree bevel and repeat the check.
- Make sure the blade and arbor collars are clean.
- Make sure the collars' recessed sides are facing the blade.
- Using 1/4 inch allen wrench supplied, make sure the arbor cap screw is firmly tightened.
- Make sure all clamps and locks are tight and there is no excessive play in any parts.

- **Keep Work Area Clean** Cluttered areas and benches invite accidents. Floor must not be slippery.

To avoid burns or other fire damage, never use the saw near flammable liquids, vapors or gases.

Plan ahead to protect your eyes, hands, face, ears.

Know Your Miter Saw. Read and understand the owner's manual and labels affixed to the tool. Learn its applications and limitations as well as the specific potential hazards peculiar to this tool.

To avoid injury from accidental contact with moving parts, don't do layout, assembly, or setup work on the miter saw while any parts are moving.

Avoid Accidental Starting. Make sure switch is "OFF" before plugging miter saw into a power outlet.

Plan your work.

Use The Right Tool. Don't force tool or attachment to do a job it was not designed to do. Use a different tool for any workpiece that can't be held in a solidly braced, fixed position.

CAUTION: This machine is not designed for cutting ferrous metals (steel, iron and iron based metals). Use this miter saw to cut only wood, wood like products or soft metals like aluminum. Other material may shatter, bind on the blade, or create other dangers.

CAUTION: When cutting any metals, sparks or hot fragments could cause a fire. To avoid this, disconnect any dust collecting bag or hose from the miter saw, and remove all traces of wood dust from inside dust traps in the miter saw.

Dress For Safety



Any power miter saw can throw foreign objects into the eyes. This can result in permanent eye damage. Wear safety goggles (not glasses) that comply with ANSI Z87.1 (shown on package). Everyday eyeglasses have only impact resistant lenses. They are not safety glasses. Safety goggles are available at Sears retail stores. Glasses or goggles not in compliance with ANSI Z87.1 could seriously hurt you when they break.

- Do not wear loose clothing, gloves, neckties or jewelry (rings, wrist watches) They can get caught and draw you into moving parts.
- Wear nonslip footwear.
- Tie back long hair.
- Roll long sleeves above the elbow.
- Noise levels vary widely. To avoid possible hearing damage, wear ear plugs or muffs when using miter saw for hours at a time.
- For dusty operations, wear a dust mask along with safety goggles.

Safety Instructions For Miter Saws (Continued)

Inspect your workpiece.

- Make sure there are no nails or foreign objects in the part of the workpiece to be cut.

Plan your work to avoid thrown pieces caused - when the workpiece binds on the blade and is torn from your hands.

Plan the way you will hold the workpiece from start to finish:

Avoid awkward operations and hand positions where a sudden slip could cause fingers or hand to move into the blade.

Don't Overreach. Keep good footing and balance.

Keep your face and body to one side of saw blade, out of line with a possible throwback.

Never cut Freehand:

- Cut only one workpiece at a time.
- Brace your workpiece solidly against the fence and table top so it will not rock or twist during the cut.
- Make sure there's no debris between the workpiece and its supports.
- Make sure no gaps between the workpiece, fence and table will let the workpiece shift after it is cut in two.
- Keep the cut off piece free to move sideways after it's cut off. Otherwise it could get wedged against the blade and could be thrown violently.
- Clear everything except the workpiece and related support devices off the table before turning the miter saw on.
- **Secure Work.** Use clamps or a vise to help hold the work when it's practical.

Use extra caution with large, very small or awkward workpieces:

- Use extra supports (tables, saw horses, blocks, etc.) for any workpiece large enough to tip when not held down to the table top.
- **Never** use another person as a substitute for a table extension, or as additional support for a workpiece that is longer or wider than the basic miter saw table.
- Do not use this saw to cut pieces too small to let you easily hold the work. The thumb side of your index (pointer) finger should not be closer to the blade than the outside edge of the fence.
- When cutting irregularly shaped workpieces, plan your work so it will not slip and pinch the blade and be torn from your hands. A piece of molding, for example, must lie flat or be held by a fixture or jig that will not let it twist, rock or slip while being cut.
- Properly support round material such as dowel rods, or tubing. They have a tendency to roll while being cut, causing the blade to "bite." To avoid this, always use a fixture designed to properly hold your workpiece.

WARNING: If planning to cut aluminum or other non-ferrous metals: Under adverse conditions, the blade can grab and throw the workpiece suddenly and unexpectedly. To avoid injury, follow all applicable safety instructions, as you normally would, and:

- Use only sawblades specifically recommended for non-ferrous metal cutting.
- Do not cut metal workpieces that must be hand held. Use auxiliary clamps or other equipment as needed.
- Cut non-ferrous metals only if you are experienced or under the supervision of an experienced person.

Whenever Saw Is Running:

WARNING: Don't allow familiarity (gained from frequent use of your miter saw) cause a careless mistake. A careless fraction of a second is enough to cause a severe injury.

Before starting your cut, watch the miter saw while it runs. If it makes an unfamiliar noise or vibrates a lot, stop immediately. Turn the saw off. Unplug the saw. Do not restart until finding and correcting the problem.

Keep Children Away. Keep all visitors a safe distance from the miter saw. Make sure bystanders are clear of the miter saw and workpiece.

Never confine the piece being cut off. Never hold it, clamp it, touch it, or use length stops against it while the blade is spinning. It must be free to move sideways on its own. If confined, it could get wedged against the blade and thrown violently.

Let the blade reach full speed before cutting.

Don't Force Tool. It will do the job better and safer at its designed rate. Feed the saw into the workpiece only fast enough to let the blade cut without bogging down or binding.

Before freeing jammed material:

- Turn switch "OFF".
- Unplug the miter saw.
- Wait for all moving parts to stop.

After finishing a cut:

- Keep holding the power head down.
- Release the switch, and wait for all moving parts to stop before moving your hands.
- If blade doesn't stop within 6 seconds, unplug the saw and follow the instructions in the "Trouble Shooting" section for fixing the blade brake before using the saw again.

Before Leaving The Saw:

Never Leave Tool Running Unattended. Turn power off. Wait for all moving parts to stop.

Make workshop child-proof. Lock the shop. Disconnect master switches. Store tool away from children and others not qualified to use the tool.

Glossary of Terms for Woodworking

Arbor

The shaft on which a cutting tool is mounted.

Bevel Cut

An angle cutting operation made through the face of the workpiece.

Compound Cut

A simultaneous bevel and miter cutting operations.

Crosscut

A cutting operation made across the width of the workpiece.

Freehand

Performing a cut without using a fence (guide), hold down or other proper device to prevent the workpiece from twisting during the cutting operation. Twisting of the workpiece can cause it to be thrown.

Gum

A sticky, sap based residue from wood products.

Heel

Misalignment of the blade.

Kerf

The amount of material removed by the blade in a through cut or the slot produced by the blade in a non-through or partial cut.

Miter Cut

An angle cutting operation made across the width of the workpiece.

Resin

A sticky, sap based substance that has hardened.

Revolutions Per Minute (RPM)

The number of turns completed by a spinning object in one minute.

Sawblade Path

The area of the workpiece or table top directly in line with either the travel of the blade or the part of the workpiece which will be, or has been, cut by the blade.

Set

The distance that the tip of the sawblade tooth is bent (or set) outward from the face of the blade.

Workpiece

The item on which the cutting operation is being performed. The surfaces of a workpiece are commonly referred to as faces, ends, and edges.

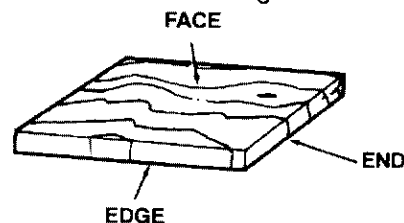

Motor Specifications and Electrical Requirements

Power Supply and Motor Specifications

The AC motor used in this saw is a universal, non-reversible type having the following specifications:

	MODEL 113.235100	MODEL 113.235200
Maximum Developed H.P.	2	3
Voltage	120	120
Amperes	12	15
Hertz (Cycles)	60	60
Phase	Single	Single
RPM	5000	5200
Shaft Rotation (blade end)	Clockwise	Clockwise

WARNING: To avoid electrical hazards, fire hazards, or damage, or damage to the tool, use proper circuit protection. Your saw is wired at the factory for 120v operation. Connect to a 120v, 15-amp branch circuit and use a 15-amp time delay fuse or circuit breaker. To avoid shock or fire, if power cord is worn or cut, or damaged in any way, have it replaced immediately.

Double Insulated

The miter saw is double insulated to provide a double thickness of insulation between you and the tool's electrical system. All exposed metal parts are isolated from the internal metal motor components with protecting insulation.

Your unit has a plug that looks like the one shown below.

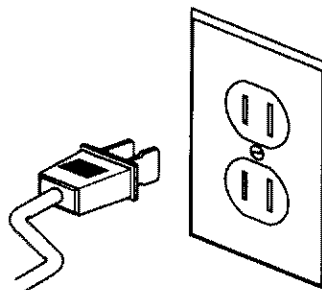

To reduce the risk of electrical shock, this appliance has a polarized plug (one blade is wider than the other). This plug will fit in a polarized outlet only one way, if the plug does not fit fully in the outlet, reverse plug. If it still does not fit, contact a qualified electrician to install the proper outlet. Do not change the plug in any way.

WARNING: Double insulation does not take the place of normal safety precautions when operating this tool.

Motor Specifications and Electrical Requirements (Continued)

DANGER: To avoid electrocution:

1. Use only identical replacement parts when servicing a tool with double insulation. Servicing should be performed by a qualified service technician.
2. Do not use in rain or where floor is wet. This tool is intended for indoor residential use only.

Motor Safety Protection

IMPORTANT: To avoid motor damage, this motor should be blown out or vacuumed frequently to keep sawdust from interfering with normal motor ventilation.

1. Connect this tool to a 120v, 15-amp branch circuit with a 15-amp time delay fuse or circuit breaker. Using the wrong size fuse can damage the motor.
2. If the motor won't start, release the trigger switch immediately. UNPLUG THE TOOL. Check the saw blade to make sure it turns freely. If the blade is free, try to start the motor again. If the motor still does not start, refer to the "Motor Trouble-Shooting Chart."
3. If the motor suddenly stalls while cutting wood, release the trigger switch, unplug the tool, and free the blade from the wood. The motor may now be restarted and the cut finished.
4. Fuses may "blow" or circuit breakers may trip frequently if:

- a. **Motor Is Overloaded**-Overloading can occur if you feed too rapidly or make too many start/stops in a short time.
 - b. Line voltages are more than 10% above or below the nameplate voltage. For heavy loads, however, the voltage at motor terminals must equal the voltage specified on nameplate.
5. Most motor troubles may be traced to loose or incorrect connections, overload, low voltage (such as small size wire in the supply circuit) or to overly long supply circuit wire. Always check the connections, the load and the supply circuit whenever motor doesn't work well. Check wire sizes and length with the Wire Size Chart below.

Wire Sizes

NOTE: Make sure the proper extension cord is used and is in good condition.

The use of any extension cord will cause some loss of power. To keep this to a minimum and to prevent overheating and motor burn-out, use the table below to determine the minimum wire size (A.W.G.) extension cord.

Length of the Conductor	Wire Sizes Required for 120v (American Wire Gage Number)
110-120V	
0-25	14
26-50	12

Table of Contents

Section	Page	Section	Page
Warranty.....	2	Assembly	9
Safety Instructions for Miter Saw	2-4	Alignment.....	10-11
Glossary of Woodworking Terms	5	Mounting the Miter Saw	12-13
Motor Specifications and Electrical Requirements	5-6	Safety Instructions for Basic Saw Operations	14-16
Unpacking and Checking Contents.....	7	Basic Saw Operations.....	16-21
Tools Needed.....	7	Maintenance and Lubrication.....	22
Unpacking	7	Sears Recommends the Following Accessories.....	23
List of Loose Parts.....	7	Trouble Shooting Guide	24-25
Getting to Know Your Miter Saw	8	Repair Parts.....	26-31



Unpacking and Checking Contents

Tools Needed

Tools required for alignment:

1. Combination Square
2. Combination wrench, 1/4" Hex "L" wrench with #2 phillips tip (supplied)



COMBINATION SQUARE



1/2" SOCKET & SOCKET WRENCH



HEX "L" W/PHILLIPS WRENCH (SUPPLIED)

COMBINATION SQUARE MUST BE TRUE

DRAW LIGHT LINE ON BOARD ALONG THIS EDGE

STRAIGHT EDGE OF BOARD 3/4" THICK THIS EDGE MUST BE PERFECTLY STRAIGHT

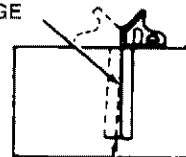

SHOULD BE NO GAP OR OVERLAP WHEN SQUARE IS FLIPPED OVER IN DOTTED POSITION

Unpacking

WARNING: To avoid injury from unexpected starting or electrical shock, do not plug the power cord into a source of power during unpacking and assembly. This cord must remain unplugged whenever you are working on the saw.

WARNING: Although small, this saw is heavy, to avoid back injury, get help whenever you have to lift the saw more than 10 inches.

Model 113.235200 and 113.235100 Miter saws, are each shipped complete in one box.

NOTE: This manual gives instructions for both 113.235200 compound miter saw and 113.235100 non-compound miter saw. The two saws are very similar in design and function. Many parts are identical. The illustrations will reflect the compound miter saw when describing most applications. Illustrations of the non-compound miter saw will also be given to explain the features that are unique to that saw.

1. Remove the miter saw from the carton by lifting the saw by the carry handle.

WARNING: If any part is missing or damaged, do not plug the saw in until the missing or damaged part is correctly replaced. To avoid electric shock, use only identical replacement parts when servicing double insulated tools.

2. Place the saw on a secure stationary work surface and look the saw over carefully.

List of Loose Parts

- | | |
|-----------------------------|---|
| A. Basic Saw Assembly | 1 |
| B. Owners Manual Form | 1 |
| C. Dust Elbow | 1 |



B

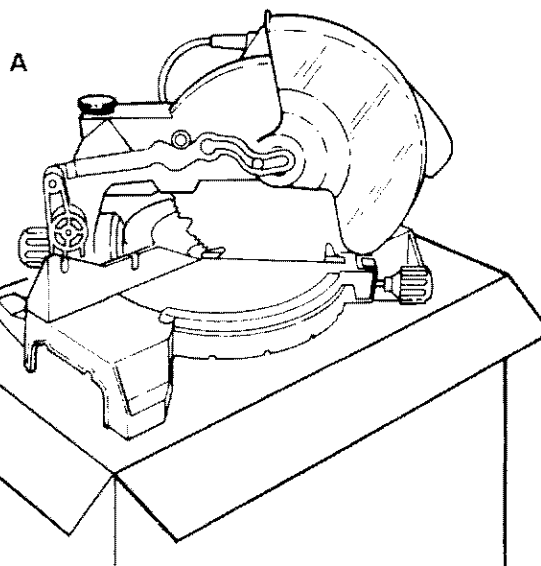

Getting to Know Your Miter Saw

1. **Warning label.**
2. **Stop Shaft** - The miter saw can be locked in the lowered position for compact storage.
3. **Miter Lock Knob** - The miter lock knob securely locks the miter saw at a desired miter angle. Index points have been provided at 0, 22.5 R/L, and 45 R/L.
4. **Miter Index Spring** - Loosen Miter Lock Knob and depress the index spring to move out of 0, 22-1/2° & 45° indexes.
5. **Bevel Lock Knob** - The bevel lock knob locks the miter saw at a desired bevel angle. Model 113.235200 only.
6. **Bevel Index Pin** - This pin allows for quick 0° and 45° bevel settings. The pin may also be pulled out far enough to override the stops. Model 113.235200 only.
7. **Lower Blade Guard** - The blade guard helps protect your hands from the blade in the raised position. To avoid binding on the workpiece, it retracts as the blade is lowered.
8. **Miter Saw Switch Handle** - The saw handle contains the trigger switch with a lock-off button. The blade is lowered into the workpiece by pushing down on the handle. The saw will return to its upright position when the handle is released.
9. **On-Off Trigger Switch** - To prevent the trigger from being accidentally engaged, a lock-off button is provided. To start the tool, push the lock-off button forward and squeeze the trigger. Release the trigger to stop the miter saw.
10. **Padlock Hole** - A hole in the switch trigger and handle has been provided so that a padlock (not supplied) could be attached to prevent unauthorized use.
11. **Miter Saw Carry Handle** - After locking the power head in the lowered position with the stop shaft, the saw is conveniently carried using this handle.
12. **Cover Plate Stop Screw** - When this screw is loosened, the cover plate is rotated to the rear, allowing for blade removal/replacement.
13. **Arbor Lock (Model 113.235200 Only)** - Allows the user to keep the blade from rotating while tightening or loosening the arbor screw during blade replacement or removal.
14. **Combination Wrench** - Used for 1/4" hex and phillips head screw adjustments. Storage is provided as shown.
15. **Base** - Supports table, holds accessories and allows for workbench or legset mounting.

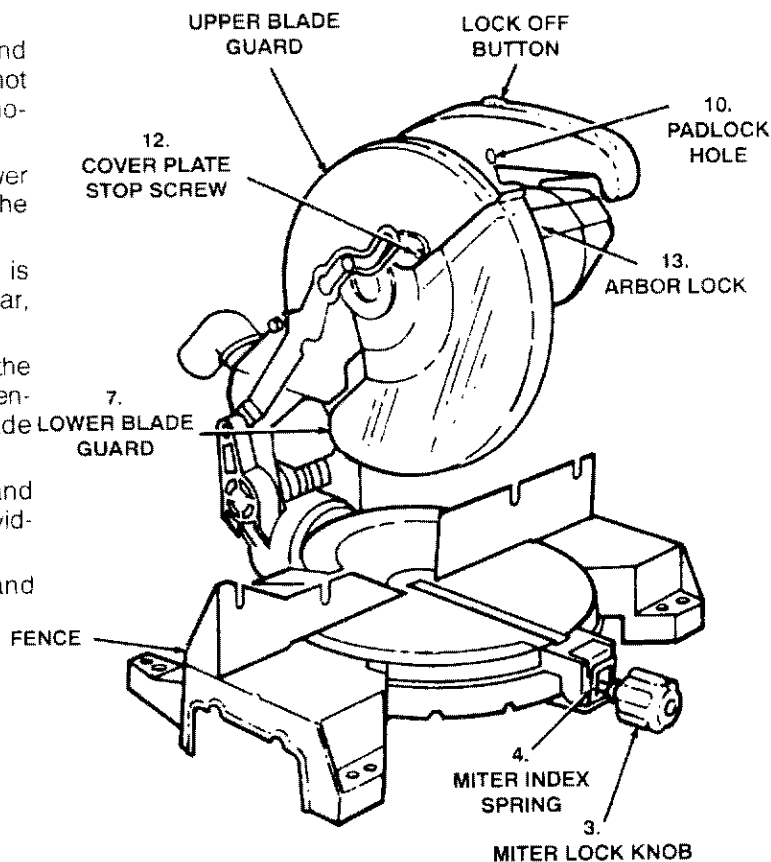
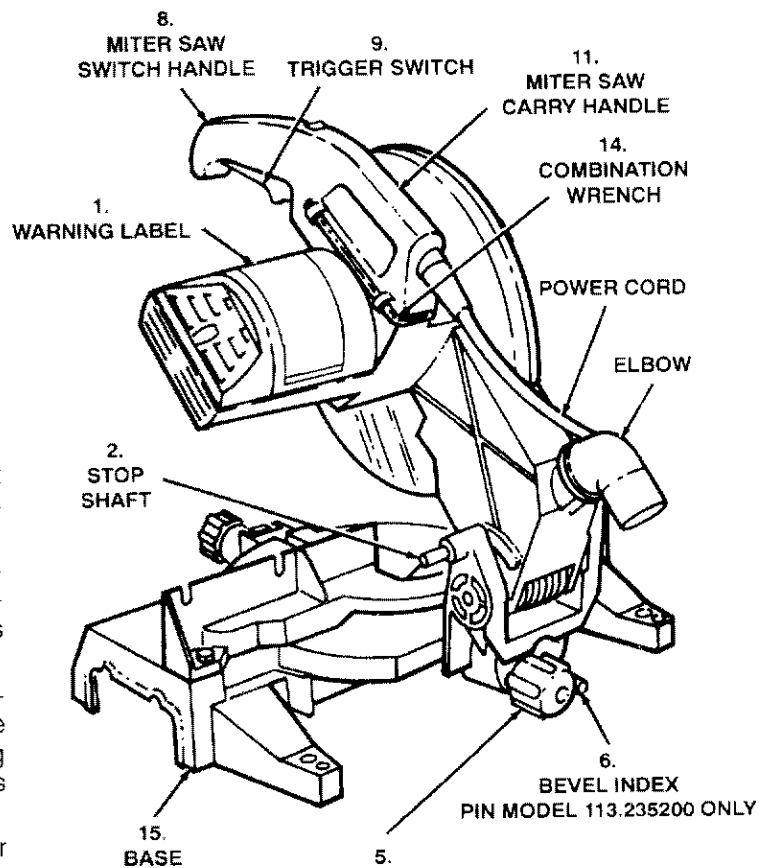

Assembly

Removing or Installing the Blade

WARNING: To avoid injury from a thrown work-piece or thrown pieces of blade, do not use a blade larger or smaller than 10" diameter.

WARNING: To avoid injury from unexpected starting, unplug the saw whenever you are removing or installing the blade.

1. Unplug the saw from the outlet.
2. Loosen the cover plate stop screw with phillips end of the combination wrench, supplied.
3. Lift the lower guard up and tilt the lower guard assembly back so the arbor screw is exposed.
- 4a. For Model 113.235200 only, find the arbor lock between the upper guard and the miter saw handle press the arbor lock and hold it in firmly while turning the arbor screw. The arbor lock will engage within one revolution
- 4b. For either saw model you may lower the blade down on to a scrap piece of wood positioned against the fence. This will serve as an alternate locking means.
5. Place the 1/4" allen end of combination wrench supplied into the arbor screw. Remove the arbor screw, outer blade collar, and the blade.

NOTE: Pay attention to pieces removed, noting their position and direction they face (see illustration). Wipe the blade collars clean of any sawdust before installing a new blade.

6. Install the new 10" blade (see recommended accessory list). Make sure the rotation arrow on the blade matches the clockwise rotation arrow on the upper guard.
7. Install the outer blade collar, and arbor screw. Turn the allen wrench counter clockwise to secure the blade. Tighten arbor screw securely.
8. Lower the lower blade guard until the slot in cover plate rests all the way down on the coverplate stop screw. Tighten the screw with phillips end of the combination wrench, supplied.

DANGER: Never use saw without cover plate securely in place. It keeps the arbor screw from falling out if it accidentally loosens, and prevents the spinning blade from coming off the machine.

9. Be sure the arbor lock is released so the blade turns freely.

NOTE: On Model 113.235200, the arbor lock can be damaged by improper use.

WARNING: Make sure the collars are clean and properly arranged. After installing a new blade, make sure the blade clears the table slot at the 0° and 45° bevel positions. Lower the blade into the lower table and check for any contact with the base or turn table structure.

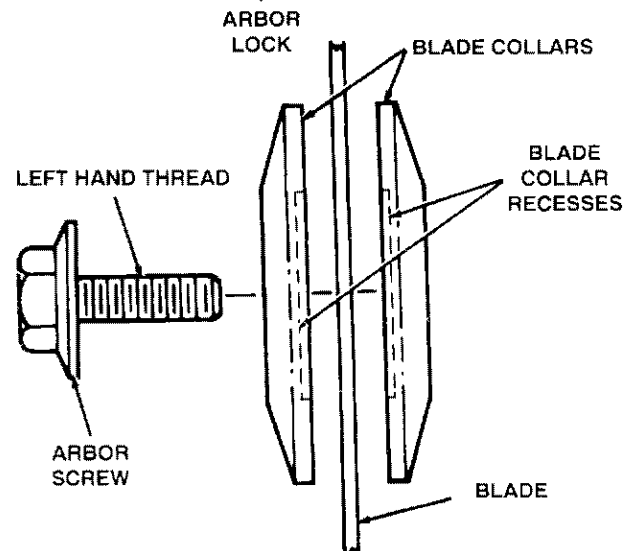
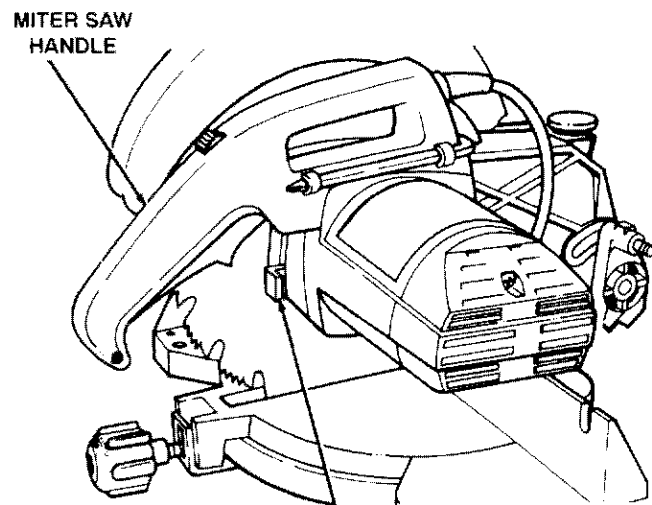
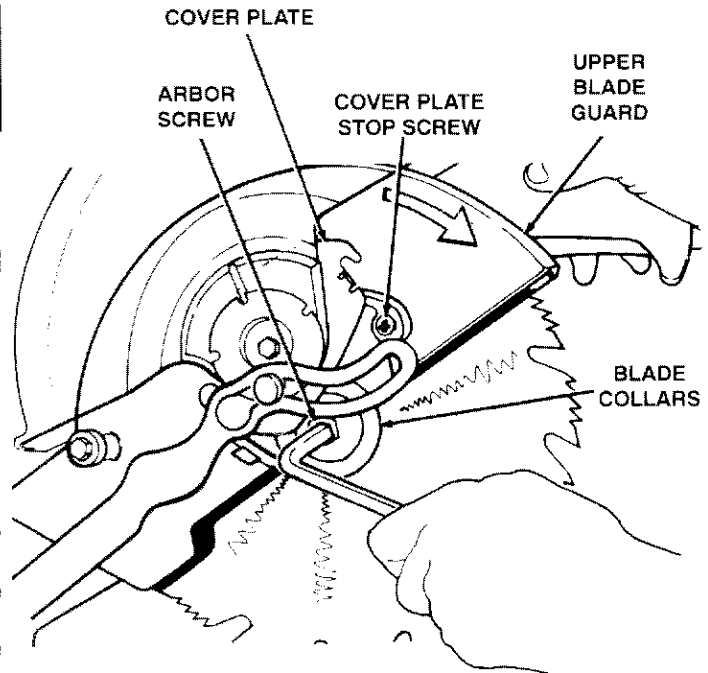

Assembly (continued)

Assembling Dust Elbow

1. Locate the dust elbow.
2. Unplug power cord.
3. With the miter arm locked in the down position, start the dust elbow onto the dust nozzle at an angle to retaining lip.
4. Firmly press the dust elbow the rest of the way onto the second retaining lip.

NOTE: At first time installation, or if assembled in a cool or cold climate, the rubber is not as flexible and will be more difficult to assemble.

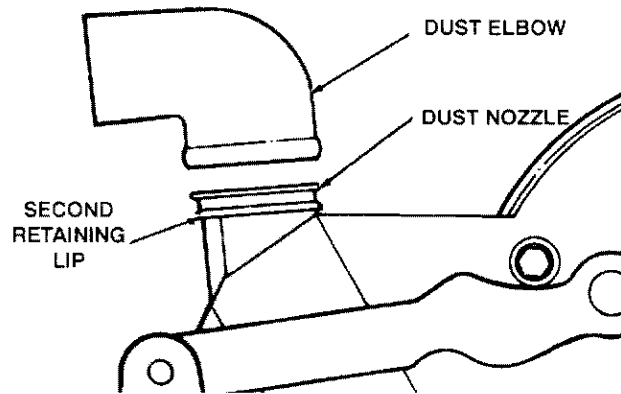

Alignment

Step One-Checking and Adjusting Blade Squareness to Fence (Miter Alignment)

WARNING: To avoid injury from unexpected starting or electrical shock, do not plug the saw in. The power cord must remain unplugged whenever you are working on the saw.

1. To check blade squareness to fence, use a combination square. Place the square against the fence and next to the blade as illustrated. Place the square so the set in the teeth won't hold it from the blade. The blade should contact the full length of the square.
2. If blade contacts full length of square, proceed to next adjustment. If blade is not square to the fence, follow the alignment procedures: a through f.
 - a. Loosen miter lock knob a half turn. The saw power head should still be secured in the lowered position by the stop shaft.

NOTE: Take the saw off its stand, bench or plywood base if readjustment is necessary.

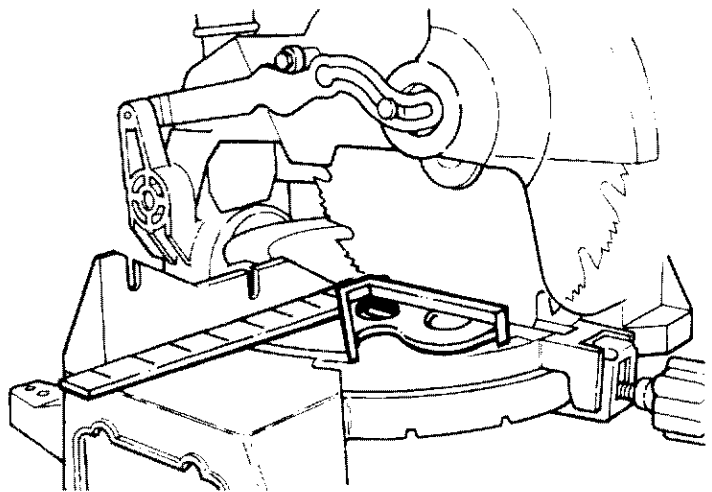

CAUTION: To keep from losing control of the unit, steady the base with one hand while loosening the two bolts with the other hand.

- b. With the unit securely resting on a large stable surface, tilt the unit by lifting up on one side or the other of the base. Using allen wrench supplied, loosen the two miter index spring cap head screws on the underside of the turn table.
- c. Return the saw to its normal resting position. Make sure the miter lock knob is loose but do not release the index spring.
- d. Use the miter saw knob to move the turn table and saw so that the blade contacts the full length of the square. Watch out for tooth set. Turn the miter lock knob clockwise to lock saw square to fence.
- e. Tilt saw as in Step b and tighten cap head screws.
- f. Recheck blade squareness to fence and readjust if necessary.

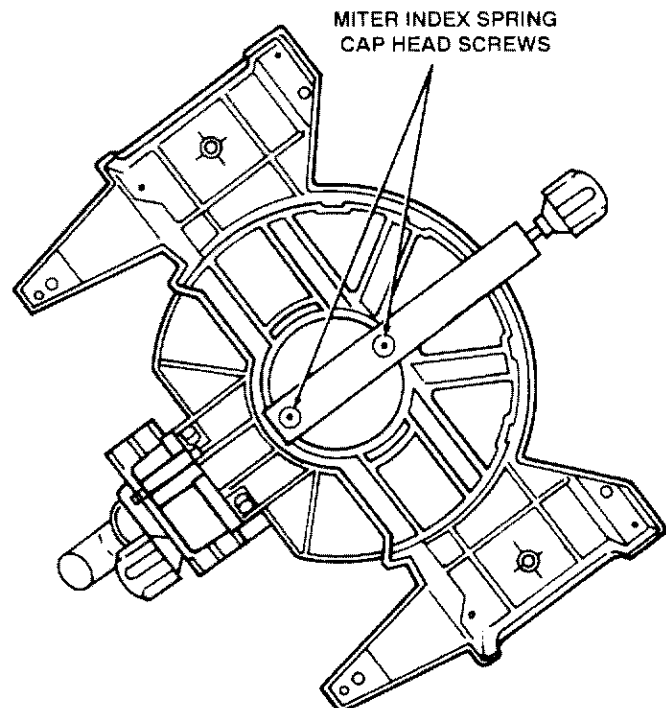

Alignment (continued)

Adjustment of Miter Scale Indicator

1. Loosen the phillips screw that holds the indicator in place.
2. Reposition the indicator and retighten screw.

WARNING: To avoid injury from unexpected starting or electrical shock, do not plug the saw in. The power cord must remain unplugged whenever you are working on the saw.

Step Two-Bevel Adjustments

NOTE: Bevel Adjustments are only performed on model 113.235200, compound miter saw. If you have Model 113.235100 saw, proceed to "Mounting Miter Saw" section.

Bevel Stop Adjustments

NOTE: The miter saw was assembled, aligned, and inspected before shipment. Alignment should be checked and any adjustments made to insure accurate cuts.

1. Check miter lock knob setting. The miter lock knob should be at the 0° position. To reset the miter angle, turn the miter lock knob counter clockwise and press down the index spring.
2. Lower the power head and lock the stop shaft. Make sure the bevel index pin is pushed in. Loosen the bevel lock knob and tilt powerhead until it contacts the 45° stop.
3. Using the square, check for accuracy of the 45° stop (when the blade makes contact with the full length of the square). Do not measure across the set of a blade tooth. Repeat this for 0° bevel. If either stop is inaccurate, follow the alignment procedures: a through g.
 - a. Using the allen wrench provided, loosen the screw which holds the inaccurate bevel index stop.
 - b. Move the power head left or right until blade makes contact with full length of square.
 - c. Tighten bevel lock knob.
 - d. Make sure the index pin is pushed in.
 - e. Slide bevel index stop over until it firmly contacts the index pin.
 - f. Tighten bevel index stop screw.
 - g. Recheck indexes for accuracy.
4. Check the bevel indicator. If indicator needs adjustment use the phillips end of the combination wrench supplied and slide the indicator to the correct reading on the scale and retighten screw.

Bevel Pivot Adjustments

1. The miter saw should bevel easily by loosening the bevel lock knob and tilting the power head to the left. If movement is tight or if there is looseness in the pivot follow the adjustment procedure: a through c.
 - a. Loosen the bevel lock knob.
 - b. Turn the hex head screw with 1/2" socket clockwise to tighten or counter clockwise to loosen.
 - c. Recheck bevel movement of the miter saw. Readjust if necessary.

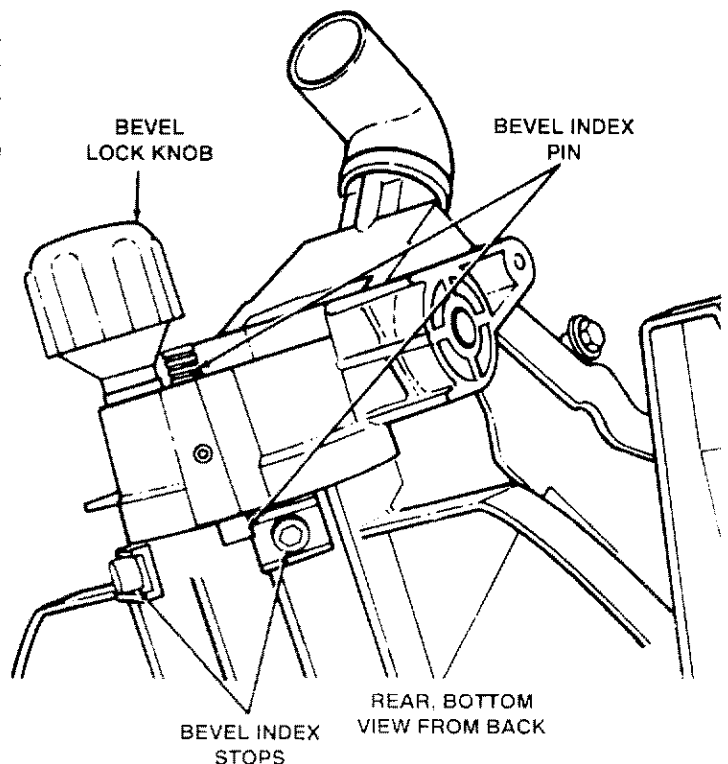
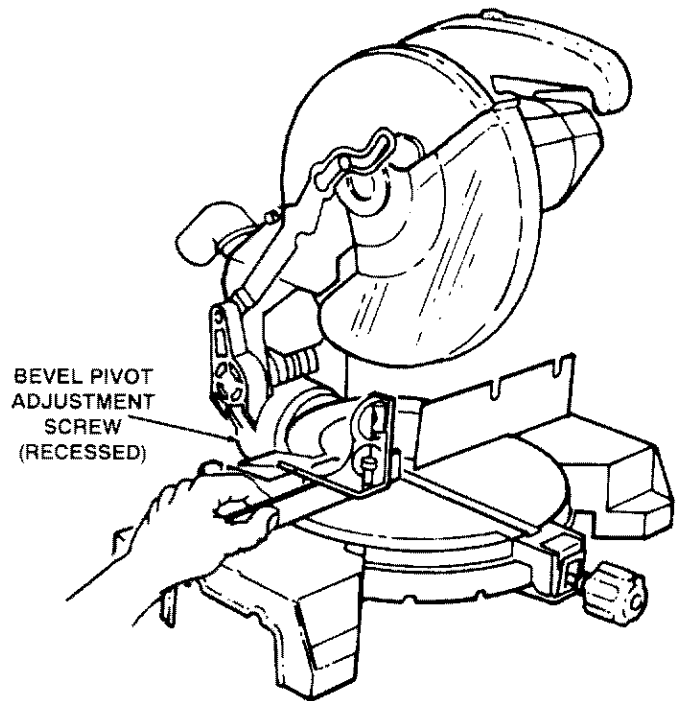

Mounting The Miter Saw

WARNING: To avoid injury from unexpected saw movement:

- Before moving the saw, lock the miter (and bevel if applicable) lock knob, and lock the power head in the lower position using the stop shaft. Unplug electric cord.
- To avoid back injury, Hold the tool close to your body. Bend your knees so you can lift with your legs, not your back. Lift by using the hand-hold areas at the bottom of the base or the carry handle.
- Never carry the miter saw by the power cord or by the trigger grip of the plastic handle. Carrying the tool by the power cord could cause damage to the insulation or the wire connections resulting in electric shock or fire.
- Place the saw so other people cannot stand behind it. Thrown debris could injure people in its path.
- Place the saw on a firm, level surface where there is plenty of room for handling and properly supporting the workpiece.
- Support the saw so the table is level and the saw does not rock.
- Bolt or clamp the saw to its support.

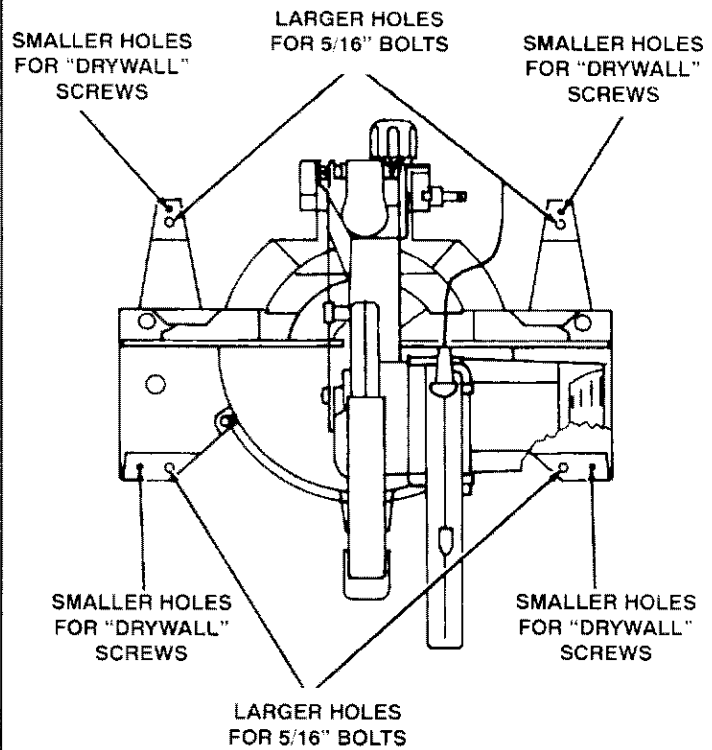

Place the saw in the desired location either on a work bench or the recommended leg set. The base of the saw has two sets of four holes to mount the miter saw, four smaller holes for "Drywall" screws and four larger holes for 5/16 bolts. (see illustration). If the saw is to be used in one location, permanently fasten it to the work bench or leg set.

Portable Applications

To mount the saw to a 3/4" piece of plywood, use the 5/16 bolt holes or the 4 drywall screw holes. The mounting board can then be clamped down to prevent it from tipping. Plywood mount also helps protect saw from damage during the rough handling associated with portable miter saw usage.

Work Bench Applications

Mount as specified in portable applications. Check for workpiece clearances to left and right of saw.

Leg Set Applications

To mount saw to below mentioned leg set, use larger holes in saw base. Attach with hardware shown, through legset holes indicated by "•" (see illustrations).

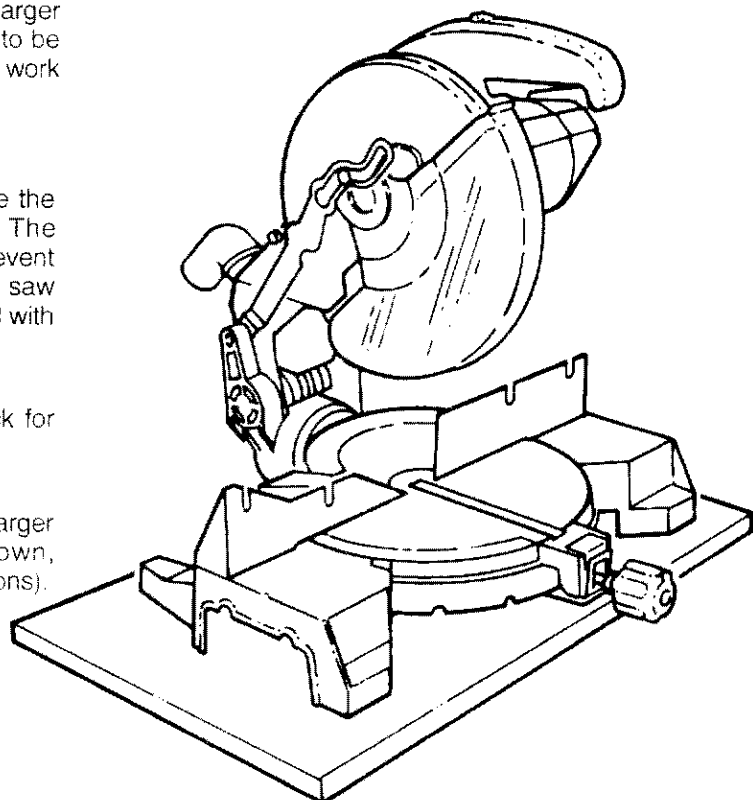

**Catalog No. 9-22246 Leg Set
Legset Mounting Holes for Miter Saws**

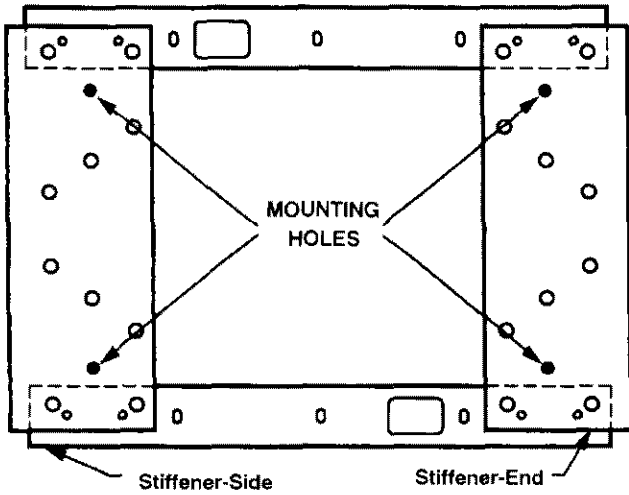

Attach miter saw to holes indicated

Recommended mounting hardware (not included)

	Qty
5/16-18x1-1/2" or longer hex head bolts	4
5/16-flat washers	4
5/16 lockwashers	4
5/16 hex nuts	4

**Mounting Board for Catalog No. 9-22244 Leg Set or
for Portable Applications**

NOTE: Attach the mounting board to the leg set first. Then mount the saw to the mounting board using the recommended hardware (not included)

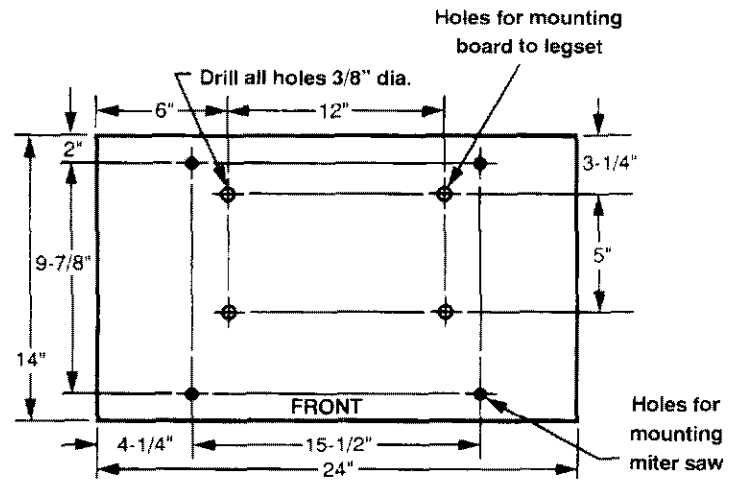

Mounting Board to legset	Qty
5/16-18x1-1/2 hex head bolts	4
5/16 flat washers	4
5/16 lock washers	4
5/16 hex nuts	4

Mounting miter saw to mounting board	Qty
5/16-18x2 or longer hex head bolts	4
5/16 flat washer	4
5/16 lock washer	4
5/16 hex nuts	4

CATALOG NO. 9-22244 LEG SET

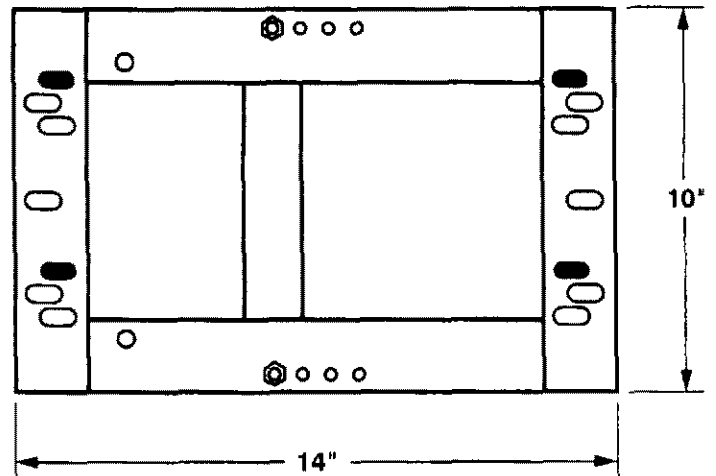
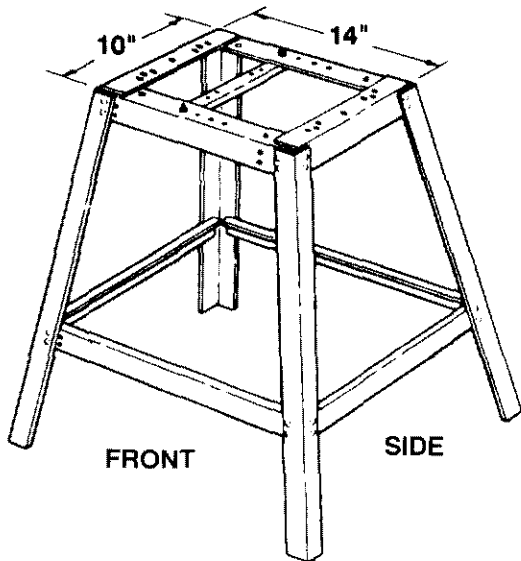

9-22244 Leg Set (Top View)
Attach mounting board to holes indicated.



Safety Instructions For Basic Saw Operations

Before Using The Miter Saw:

WARNING: To avoid mistakes that could cause serious, permanent injury, do not plug the miter saw in until the following steps are completed.

- Completely Assemble and Align Saw. (See "Assembly" and "Alignment" sections).
- Learn the use and function of the ON-OFF switch, upper and lower blade guards, stop shaft, bevel lock knob (model 113.235200 only) and cover plate stop screw. ("See Getting To Know Your Miter Saw" Section.).
- Review and understand all safety instructions and operating procedures in this manual.
- Review the maintenance methods for this miter saw. (See Maintenance Section).

To avoid injury or death from electrical shock:

- Make sure your fingers do not touch the plug's metal prongs when plugging or unplugging the miter saw.

BEFORE EACH USE:

Inspect you saw.

Disconnect The Miter Saw. To avoid injury from accidental starting, unplug the saw, before changing the setup, changing the blade or adjusting anything.

Compare the direction of rotation arrow on the guard to the direction arrow on blade. The blade teeth should always point downward at the front of the saw.

Tighten the arbor screw.

Tighten the cover plate stop screw.

Check Damaged Parts.

 Check for:

- Alignment of moving parts,
- Damaged electric cords,
- Binding of moving parts,
- Broken parts,
- Stable mounting
- Function of arm return spring and lower guard: Push the arm all the way down, then let it rise up until it stops by itself. Check the lower guard to see if it closed fully. If it did not, follow the instructions in the "Trouble Shooting" section.
- Other conditions that may affect the way the miter saw works.

Keep Guards in Place, in working order, and in proper adjustment.

If any part of this miter saw is missing, bent, or broken in any way, or any electrical parts don't work, turn the saw off and unplug it. **Replace** damaged, missing, or failed parts before using the saw again.

Maintain Tools With Care. Keep the miter saw clean for best and safest performance. Follow instructions for lubricating. **DON'T** put lubricants on the blade while it's spinning.

Remove Adjusting Wrench and return it to proper storage location before turning on tool.

To avoid injury from jams, slips or thrown pieces:

- **Use Only Recommended Accessories.** (See "Accessory" Section). Consult this Owner's manual for recommended accessories. Follow the instructions that come with the accessories. The use of improper accessories may cause risk of injury to persons.
- Choose the right 10-inch diameter blade for the material and the type of cutting you plan to do.
- Make sure the blade is sharp, undamaged and properly aligned. With the saw unplugged, push the power-head all the way down. Hand spin the blade and check for clearance. Tilt the power-head to 45 degree bevel and repeat the check.
- Make sure the blade and arbor collars are clean.
- Make sure the collars' recessed sides are facing the blade.
- Using 1/4" hex end of combination wrench supplied, make sure the arbor screw is firmly tightened.
- Make sure all clamps and locks are tight and there is no excessive play in any parts.
- **Keep work area clean.** Cluttered areas and benches invite accidents. Floor must not be slippery.

To avoid burns or other fire damage, never use the miter saw near flammable liquids, vapors or gases.

Plan ahead to protect your eyes, hands, face, ears.

Know your miter saw. Read and understand the owner's manual and labels affixed to the tool. Learn its application and limitations as well as the specific potential hazards peculiar to this tool.

To avoid injury from accidental contact with moving parts, don't do layout, assembly, or setup work on the miter saw while any parts are moving.

Avoid Accidental Starting. Make sure switch is "OFF" before plugging miter saw into a power outlet.

Plan your work.

Use The Right Tool. Don't force tool or attachment to do a job it was not designed to do. Use a different tool for any workpiece that can't be held in a solidly braced, fixed position.

CAUTION: This machine is not designed for cutting ferrous metals (steel, iron and iron based metals). Use this miter saw to cut only wood, wood like products or soft metals like aluminum. Other material may shatter, bind on the blade, or create other dangers.

CAUTION: When cutting any metals, sparks or hot fragments could cause a fire. To avoid this, disconnect any dust collecting hose from the miter saw, and remove all traces of wood dust from inside dust traps in the miter saw.

Dress For Safety.

Any power miter saw can throw foreign objects into the eyes. This can result in permanent eye damage. Wear safety goggles (not glasses) that comply with ANSI Z87.1 (shown on package). Everyday eyeglasses have only impact resistant lenses. They are not safety glasses. Safety goggles are available at Sears retail stores. Glasses or goggles not in compliance with ANSI Z87.1 could seriously hurt you when they break.

- Do not wear loose clothing, gloves, neckties or jewelry (rings, wrist watches). They can get caught and draw you into moving parts.
- Wear nonslip footwear.
- Tie back long hair.
- Roll long sleeves above the elbow.
- Noise levels vary widely. To avoid possible hearing damage, wear ear plugs or muffs when using miter saw for hours at a time.
- For dusty operations, wear a dust mask along with safety goggles.

Inspect your workpiece.

- Make sure there are no nails or foreign objects in the part of the workpiece to be cut.

Plan your work to avoid thrown pieces caused - when the workpiece binds on the blade and is torn from your hands.

Plan the way you will hold the workpiece from start to finish:

Avoid awkward operations and hand positions where a sudden slip could cause fingers or hand to move into the blade.

Don't Overreach. Keep good footing and balance. Keep your face and body to one side, out of line with a possible throwback.

Never cut Freehand:

- Brace your workpiece solidly against the fence and table top so it will not rock or twist during the cut.
- Make sure there's no debris between the workpiece and its supports.
- Make sure no gaps between the workpiece, fence and table will let the workpiece shift after it is cut in two.
- Keep the cut off piece free to move sideways after it's cut off. Otherwise, it could get wedged against the blade and thrown violently.
- Clear everything except the workpiece and related support devices off the table before turning the miter saw on.
- **Secure Work.** Use clamps or a vise to help hold the work when it's practical.

Use extra caution with large, very small or awkward workpieces:

- Use extra supports (tables, saw horses, blocks, etc.) for any workpieces large enough to tip when not held down to the table top.
- **Never** use another person as a substitute for a table extension, or as additional support for a workpiece that is longer or wider than the basic miter saw table or to help feed, support or pull the workpiece.
- Do not use this saw to cut pieces too small to let you easily hold the work while you keep the thumb side of your index (pointer) finger against the outside edge of the fence.

- When cutting irregularly shaped workpieces, plan your work so it will not slip and pinch the blade and be torn from your hands. A piece of molding, for example, must lie flat or be held by a fixture or jig that will not let it twist, rock or slip while being cut.
- Properly support round material such as dowel rods, or tubing. They have a tendency to roll while being cut, causing the blade to "bite." To avoid this, always use a fixture designed to properly hold your workpiece.

WARNING: If planning to cut aluminum or other non-ferrous metals: Under adverse conditions, the blade can grab and throw the workpiece suddenly and unexpectedly. To avoid injury, follow all applicable safety instructions, as you normally would, and:

- Use only sawblades specifically recommended for non-ferrous metal cutting.
- Do not cut metal workpieces that must be hand held. Use auxiliary clamps or other equipment as needed.
- Cut non-ferrous metals only if you are experienced or under the supervision of an experienced person.

Whenever Saw Is Running:

WARNING: Don't allow familiarity (gained from frequent use of your miter saw) cause a careless mistake. A careless fraction of a second is enough to cause a severe injury.

Before starting your cut, watch the miter saw while it runs. If it makes an unfamiliar noise or vibrates a lot, stop immediately. Turn the saw off. Unplug the saw. Do not restart until finding and correcting the problem.

Basic Saw Operations

WARNING: For your convenient use, your saw has a blade brake. The brake is not a safety device. Never rely on it to replace proper use of the guard on your saw. If the blade does not stop within 6 seconds, unplug the saw and follow the instructions in the Trouble Shooting section for fixing the brake before using saw again.

Body and Hand Position

Proper positioning of your body and hands when operating the miter saw will make cutting easier and safer. Never place hands near cutting area. Place hand at least 4" from path of blade. Hold workpiece firmly to the fence to prevent movement toward the blade. Keep hands in position until trigger has been released and the blade has completely stopped. Before making a cut, make a "dry run" with the power off so you can see the path of the blade.

WARNING: Do not try to cut short pieces, you cannot properly support the workpiece and keep your hold down hand the required distance from the blade.

Keep Children Away. Keep all visitors a safe distance from the miter saw. Make sure bystanders are clear of the miter saw and workpiece.

Never confine the piece being cut off. Never hold it, clamp it, touch it, or use length stops against it while the blade is spinning. It must be free to move sideways on its own. If confined, it could get wedged against the blade and thrown violently.

Let the blade reach full speed before cutting.

Don't Force Tool. It will do the job better and safer at its designed rate. Feed the saw into the workpiece only fast enough to let the blade cut without bogging down or binding.

Before freeing jammed material:

- Turn switch "OFF".
- Unplug the miter saw.
- Wait for all moving parts to stop.

After finishing a cut:

- Keep holding the power head down.
- Release the switch, and wait for all moving parts to stop before moving your hands.
- If blade, doesn't stop within 6 seconds, unplug the saw and follow the instructions in the Trouble Shooting section for fixing the blade brake before using the saw again.

Before Leaving The Saw:

Never Leave Tool Running Unattended. Turn power off. Wait for all moving parts to stop.

Make workshop child-proof. Lock the shop. Disconnect master switches. Store tool away from children and others not qualified to use the tool.

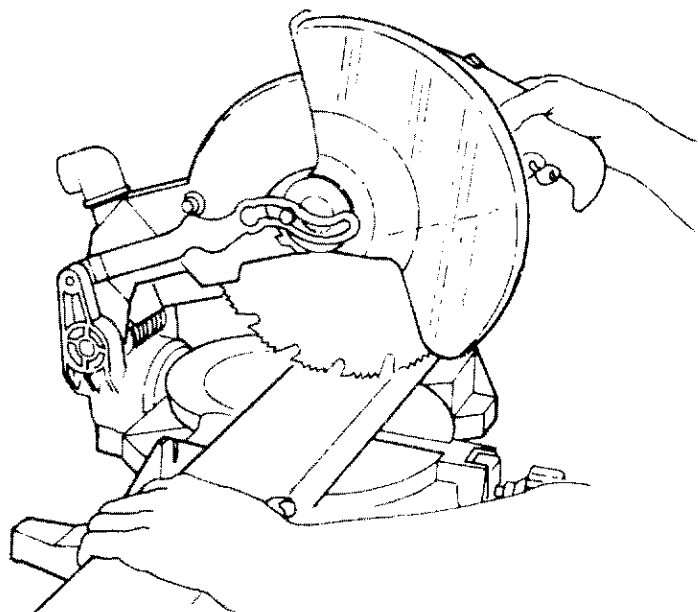

Basic Saw Operations (Continued)

Miter Cut

When a miter cut is required, loosen the miter lock knob, depress the index spring, and move the saw to the desired angle. Retighten miter lock knob. Do not stand in front of the saw table. Move with the handle to the miter angle to make the cut.

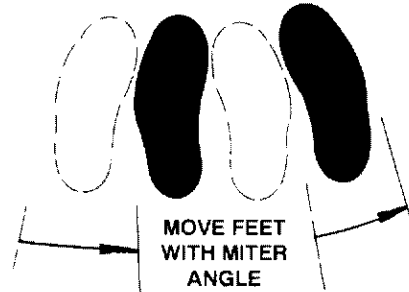
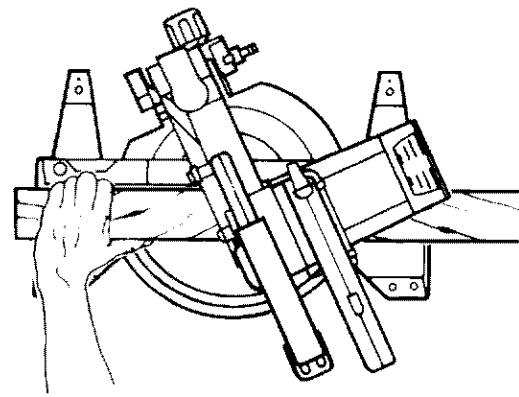

Bevel Cut

Model 113.235200 Compound Miter Saw Only:

When a bevel cut is required, loosen bevel lock knob, tilt the blade to desired bevel angle. Lock the bevel lock knob. Stand to the left side of the handle to make the cut.

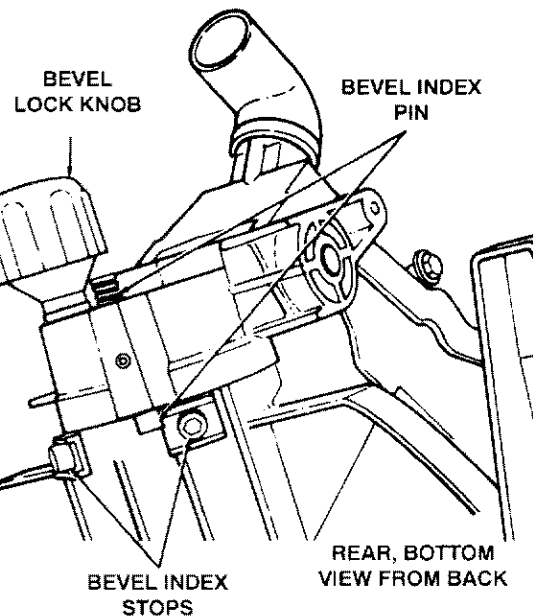
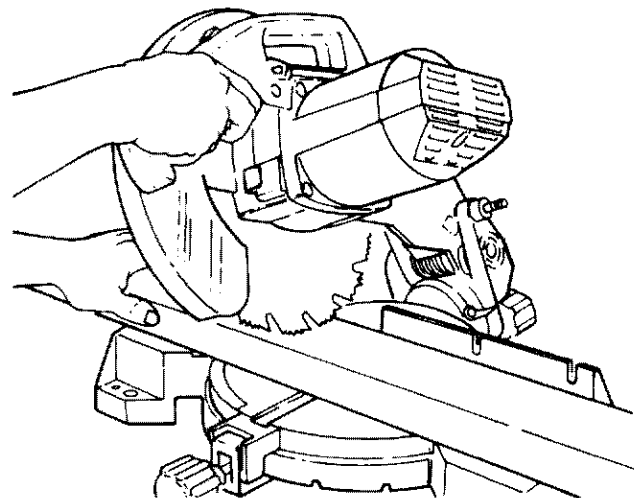

Overriding the Bevel Stops

Use the 0° and 45° bevel stops for precise, repeatable bevel indexing.

Occasionally, when cutting a bevel or compound cut, you may need to set the bevel angle a small amount beyond the 0° or 45° bevel stop. This is very easily done by pulling the bevel index pin out and locking the bevel knob.

Basic Saw Operations

Compound Cut

Model 113.235200 Compound Miter Saw Only:

When a compound cut is required, select the correct bevel and miter position. Move your feet and body with the handle to the desired miter angle to make the cut.

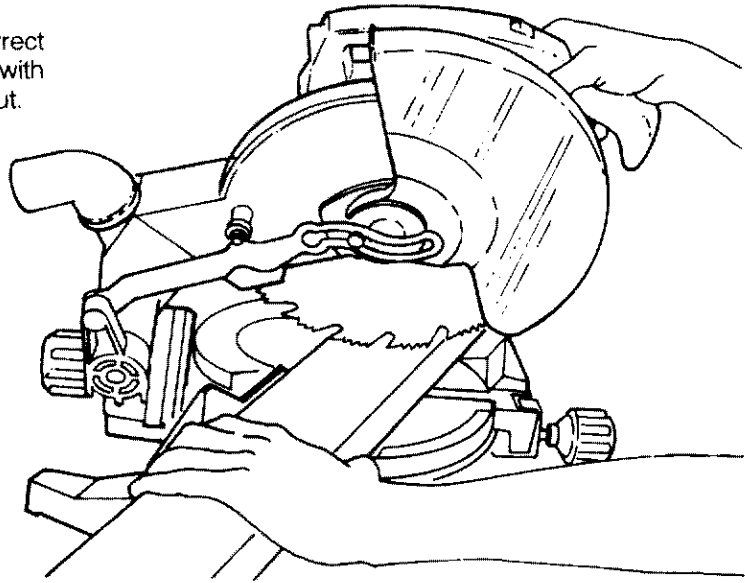

Cutting Bowed Material

Before cutting a workpiece, check to make sure it is not bowed. If it is bowed the workpiece must be positioned and cut as illustrated. Do not position workpiece incorrectly or try to cut the workpiece without the support of the fence. This will cause pinching of the workpiece on the blade. The workpiece could suddenly jump or move and your hand could hit the blade.

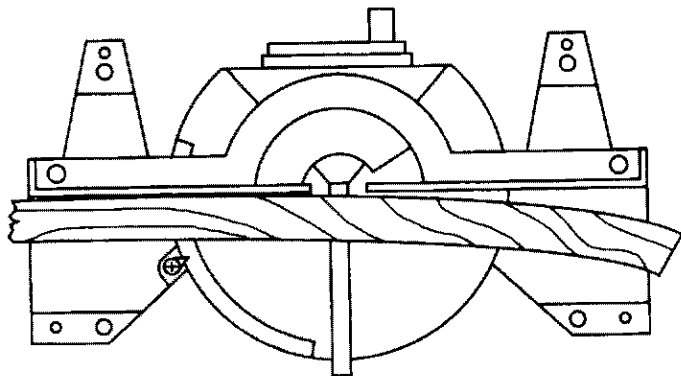

CORRECT

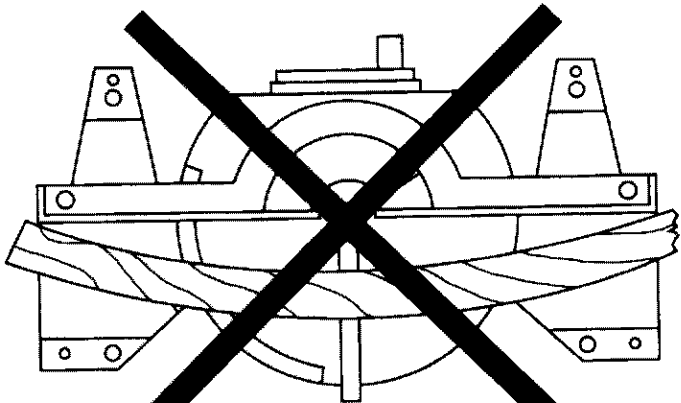

INCORRECT

Basic Saw Operations (Continued)

Workpiece Support

Long pieces need extra supports. The supports should be placed along the workpiece so the workpiece does not sag and your hand holding the workpiece is positioned 4" or more from the blade path. The support should let the workpiece lay flat on the base and work table during the cutting operation.

NOTE: When mounted on a large flat surface, the miter saw table is 3-1/2" high. Two finished 2x4's on these sides can be used as work support extension.

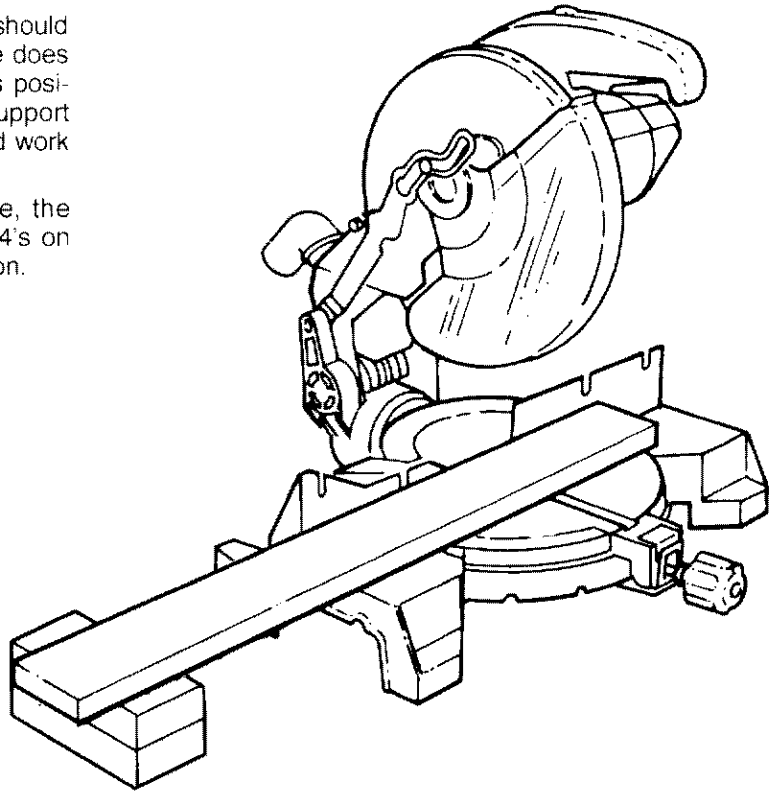

Auxiliary Fence

Certain types of molding need a fence face extension due to the size and position of the workpiece. Slots are provided in the fence to attach an auxiliary fence. Get a straight piece of wood typically 1/2 inch thick by 4-1/4 inches high by 19-1/4 inches long. To attach auxiliary fence, place the piece of wood on the miter saw fence. Mark the locations from the backside of the miter saw fence. Drill .200"-.250" holes, then countersink the holes on front of wood to receive #10 flat head screws. Attach the auxiliary fence securely and make a full depth cut. This will create the blade slot. Check for interference between the auxiliary fence and lower blade guard. Correct any interference before proceeding. The auxiliary fence is used with the saw in the 0° bevel position. If a bevel cut is desired, the auxiliary fence will have to be removed.

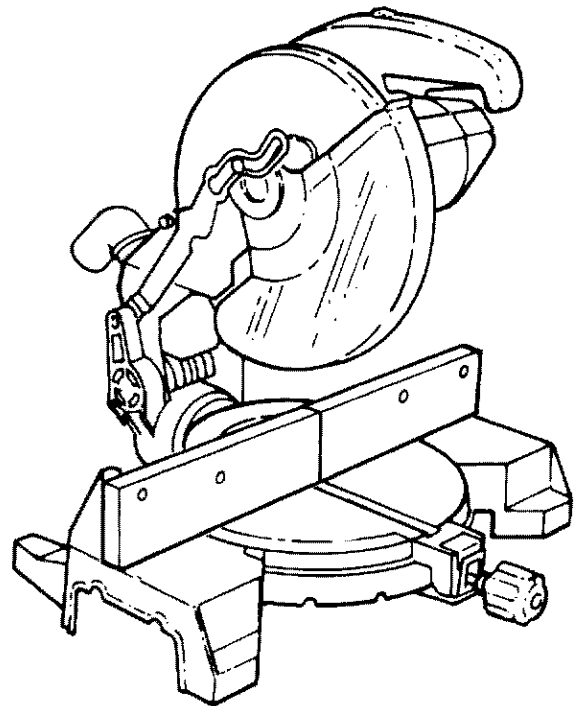

Basic Saw Operations

Cutting a Dimensional 4x4 (3-1/2" x 3-1/2" actual) with one cut.

A dimensional 4x4 may be cut with one cut by attaching an auxiliary fence of 7/8" thickness, with screws to the miter saw fence as shown on previous page.

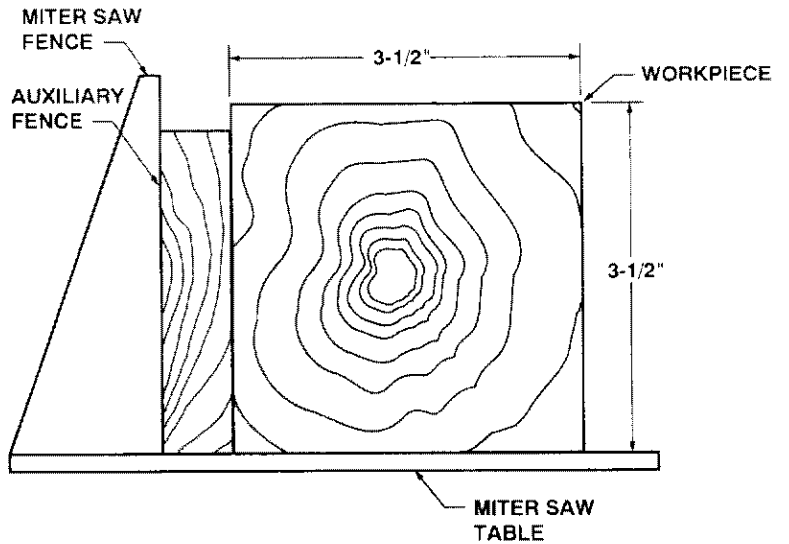

Vertical Bevel Cutting

To make a miter cut in a 2x4 workpiece (actual 1-5/8" x 3-1/2") in the vertical position (on edge) a spacer, such as the auxiliary fence described in the previous page, is required.

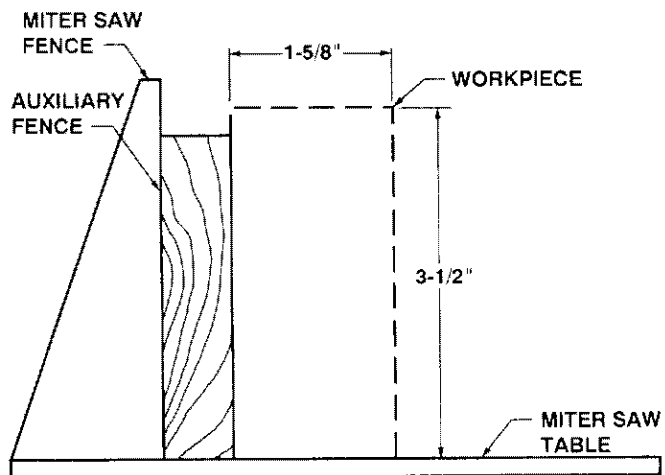

Basic Saw Operations (Continued)

Tips for Cutting Compound Miters

Model 113.235200 Only:

A compound miter is a cut requiring both a miter setting and bevel setting. A compound miter is used for making frames or boxes that have sloping sides and are wide at one end and narrow at the opposite end. Compound miters are "tricky" to make because the miter setting and bevel setting are directly related to each other. Every time the miter setting is changed the bevel setting must also be adjusted; likewise every adjustment to bevel requires a corresponding adjustment to miter. Because it may take several tries to obtain the desired angle it is advisable to make test cuts in a scrap piece of material.

Cutting Crown Moldings

Plan Ahead so that you are not tempted to reach across saw blade to steady newly severed workpiece.

Two Methods to Cut Crown Moldings

1. Workpiece standing up, usually cut inverted from ceiling mounted orientation. Fixturing: Accessory mounted crown molding jigs which locate workpiece. See recommended accessories. (Table clamp is helpful). Hand is on fence when the cuts are made. All cuts are made at 0° bevel setting.

Alternate fixturing: Auxiliary fence as shown on page 19 plus table clamps.

2. Workpiece lying flat for compound cut (see chart).

Model 113.235200 Only:

Miter and Bevel Settings for Standard Crown Molding Lying Flat on Miter Saw Table.

BEVEL SETTING	MITER SETTING	TYPE OF CUT
33.8°	31.6° Right	LEFT SIDE, INSIDE CORNER 1. Position top molding against fence. 2. Left side is finished piece.
33.8°	31.6° Left	RIGHT SIDE, INSIDE CORNER 1. Position bottom of molding against fence. 2. Left side is finished piece
33.8°	31.6° Left	LEFT SIDE, OUTSIDE CORNER 1. Position bottom of molding against fence. 2. Right side is finished piece.
33.8°	31.6° Right	RIGHT SIDE, OUTSIDE CORNER 1. Position top of molding against fence. 2. Right side is finished piece.

NOTE: On all above cuts lay molding with broad back surface flat on table.

PRETESTING COMPOUND SETTINGS ON SCRAP MATERIAL IS EXTREMELY IMPORTANT!

Tips For Cutting Crown Molding Lying Flat

Model 113.235200 Only:

A compound miter saw is excellent for cutting crown molding. Crown molding is difficult to cut because in order to fit correctly it must be precisely mitered.

All Standard (U.S.) crown molding has a top rear angle (fits next to ceiling) of 52° and a bottom rear angle (fits against wall) of 38°.

NOTE: Above angles assume that the constructed wall corner is exactly 90°. In typical construction, this is not always the case. Measure wall and make necessary adjustments to angles.

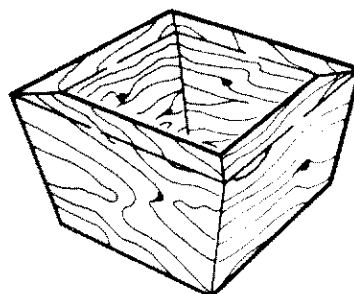
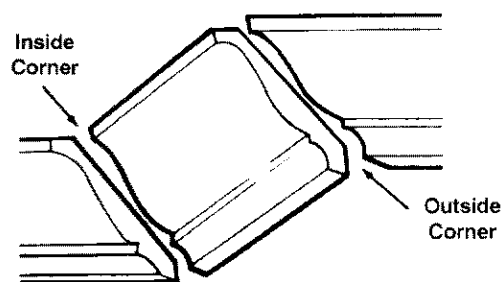

Maintenance and Lubrication

Maintenance

DANGER: Never put lubricants on the blade while it's spinning.

WARNING: To avoid injury from unexpected starting or electrical shock, unplug the power cord before working on the saw.

WARNING: For your safety, this saw is double insulated. To avoid electrical shock, fire or injury, use only parts identical to those identified in the parts list reassemble exactly as original assembly to avoid electrical hazards.

Replacing Carbon Brushes

The carbon brushes furnished will last approximately 50 hours of running time or 10,000 on/off cycles. Replace both carbon brushes when either has less than 1/4" length of carbon remaining. To inspect or replace first unplug the saw. Then remove the motor cap on the end of the motor by removing 2 screws. Remove the lead wires from the tabs on the brushes, then pull out the brushes. To reassemble reverse the procedure. Tighten the screws snugly but do not overtighten.

Lubrication

All the motor bearings in this tool are lubricated with a sufficient amount of high grade lubricant for the life of the unit under normal operating conditions, therefore, no further lubrication is required. (See below.)

Infrequent Lubrication as Required:

1. Lubrication of arm pivot for free movement.
 - a. Apply oil between washer and contact face of Table/Pivot casting.
 - b. Apply oil to pivot shaft next to inside surface of ears on arm casting.

NOTE: Disassembly should be done by an authorized service technician. Removal of the upper guard and the stopshaft is necessary before pivot can be disassembled. Pay close attention to the spring-end positions in the castings...mark with chalk to avoid later confusion.

2. Lubrication of mechanism which pivots lower guard: (see picture) Use light household oil (sewing machine oil) or a pressurized light spray oil on metal-to-metal or metal-to-plastic guard contact areas as required for smooth, quiet operation. Avoid excess oil to which sawdust will cling. Lubricate the lower guard spacer, roller, pivot plate and link pivot.
3. Lubrication of miter index indents: Use a small amount of grease on the miter index indents that are located below the table on the front of the unit.

NOTE: To reinstall the same brushes, first make sure the brushes go back in the way they came out. This will avoid a break in period that reduces performance and increases wear.

Lower Blade Guard

Do not use the saw without the lower guard. The lower blade guard is attached to the saw for protection. Should the lower guard become damaged, do not use the saw until damaged guard has been replaced. Develop a regular check to make sure the lower guard is working properly. Clean the lower guard of any dust or build up with a damp cloth.

CAUTION: Do not use solvents on the guard. They could make the plastic "cloudy" and brittle..

WARNING: When cleaning lower guard unplug the saw from the outlet to avoid unexpected start-up.

Saw Dust

Periodically, sawdust will accumulate under the work table and base. This could cause difficulty in the movement of the work table when setting up a miter cut. Frequently blow out or vacuum up the sawdust.

WARNING: If blowing sawdust, wear proper eye protection to keep debris from blowing into eyes.

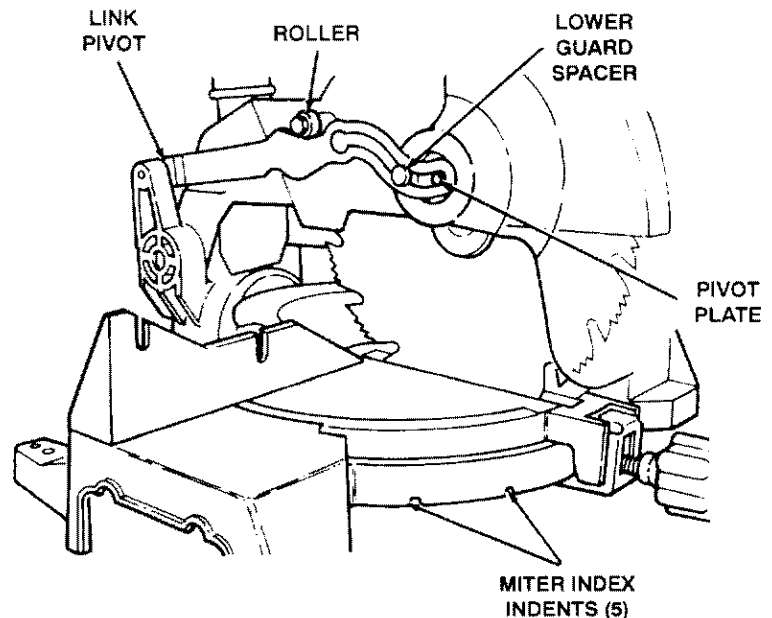

Sears Recommends the Following Accessories

Recommended Accessories

WARNING: To avoid injury from unsafe accessories, use only accessories shown on the recommended accessories list in this manual.

Prohibited Accessories

The use of any cutting tool except 10" saw blades which meet the requirement under recommended accessories is prohibited. Do not use accessories such as shaper cutters or dado sets. Ferrous metal (metal with iron in it) cutting and the use of abrasive wheels are prohibited. See **WARNING** and **CAUTION** notes in the "Safety Instructions For Basic Saw Operations" Section. If planning to saw non-ferrous metal see those **WARNING** and **CAUTION** notes in the "Safety Instructions For Basic Saw Operations" Section.

Leg Sets.....	9-22244
.....	9-22246
Carbide-Tipped Blades:	
Trim Saw.....	See Catalog
Cut-Off.....	See Catalog
Combination.....	See Catalog
Plywood/Particle Board	See Catalog
Non-Carbide Tipped Blades:	
Cross Cut/Plywood	See Catalog
Combination.....	See Catalog
Clamp	9-29000
Table Extensions	9-29001
Crown Molding Jig.....	9-29002
Dust Bag.....	9-23467
1-1/4" Sawdust Collector Hose	9-17866

Basic Blade Requirements

- 10" Diameter
- Blades marked for 5,500 RPM or higher
- 5/8" Diameter Arbor Hole



Trouble Shooting Guide - Motor

PROBLEM	PROBABLE CAUSE	SUGGESTED CORRECTIVE ACTION
Brake does not stop blade within 6 seconds.	<ol style="list-style-type: none"> Brushes not seated or lightly sticking. Motor brake winding-overheated from use of not-recommended blade or rapid on/off cycling. Arbor screw loose. Other. 	<ul style="list-style-type: none"> -Inspect/clean/replace brushes (see maintenance section). -Use a recommended blade. -Let cool down -Retighten -Authorized service. Check motor brake winding, switch, condition of commutator.
Motor does not start.	<ol style="list-style-type: none"> Fuse. Brushes worn. Other. 	<ul style="list-style-type: none"> -15-Amp time delay fuse, or circuit breaker. -See "Maintenance" section. -Authorized service.
Brush sparking when switch released.	<ol style="list-style-type: none"> Normal-automatic brake working properly. 	-None

Trouble Shooting Guide - General

PROBLEM	PROBABLE CAUSE	SUGGESTED CORRECTIVE ACTION
Blade hits table.	<ol style="list-style-type: none"> Misalignment. 	-Get authorized Sears Service.
Angle of cut not accurate.	<ol style="list-style-type: none"> Misalignment. 	-See "Alignment" section.
Can't move miter adjustment.	<ol style="list-style-type: none"> Sawdust under table. 	<ul style="list-style-type: none"> -Vacuum or blow out dust. WEAR EYE PROTECTION
Power-head wobbles.	<ol style="list-style-type: none"> Loose pivot points. 	-See "Alignment" section.
Power-head won't fully rise or blade guard won't fully close.	<ol style="list-style-type: none"> Part failure. Pivot spring not replaced properly after service. Sawdust build-up 	<ul style="list-style-type: none"> -Get authorized Sears Service. -Get authorized Sears Service. -Clean and lubricate moving parts.
Blade binds, jams, burns wood.	<ol style="list-style-type: none"> Improper operation. Dull blade. Improper blade Warped blade. 	<ul style="list-style-type: none"> -See "Basic Saw Operation" section. -Replace or sharpen blade. -Replace with 10" diameter blade designed for the material being cut. -Replace blade.
Tool vibrates or shakes.	<ol style="list-style-type: none"> Saw blade not round. Saw blade damaged. Saw blade loose.- Other. 	<ul style="list-style-type: none"> -Replace blade. -Replace blade. -Tighten arbor screw. -Get authorized Sears Service.
Power head is difficult to move down from upper stop.	<ol style="list-style-type: none"> Mechanism which pivots lower guard is sticking. Sawdust build-up in guard area. 	<ul style="list-style-type: none"> -Clean and lubricate lower guard mechanism. (See lubrication instructions on page 22) -Clean and lubricate lower guard mechanism (See lubrication instructions on page 22)

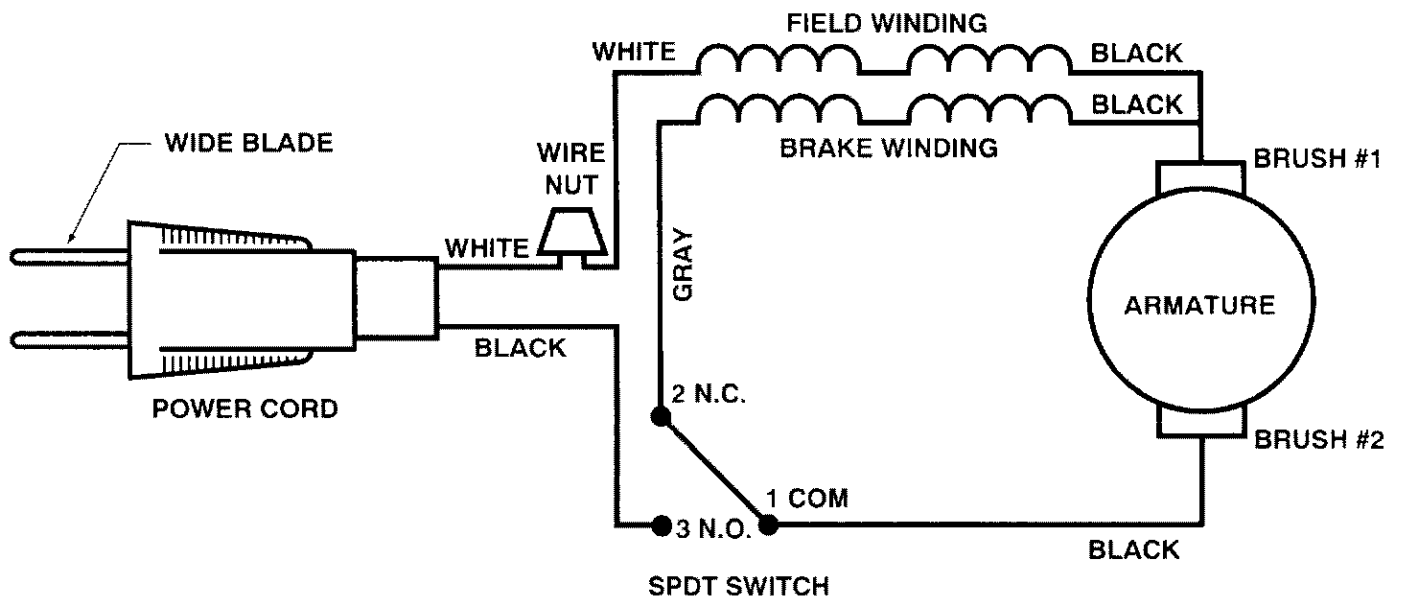

Circuit Diagram

Trouble Shooting of brake by qualified service person only.

1. Check commutation at no load. If there is a heavy sparking which follows the curvature of the commutator: replace the armature.
2. To continue trouble shooting, now unplug the power cord.
3. Install new brushes, especially if delayed come-in of brake has been noticed before failure.
4. Check brake circuit for continuity: remove motor cap and brushes. Use ohmmeter to check continuity from brush terminal to brush terminal. If open, locate exact place using ohmmeter. As indicated by test, tighten connection or replace field assembly or replace switch.
5. After repair, check direction of blade rotation vs. guard arrow.

Repair Parts

PARTS LIST FOR CRAFTSMAN 10" MITER SAWS MODEL NO. 113.235200 AND 113.235100

FIGURE 1

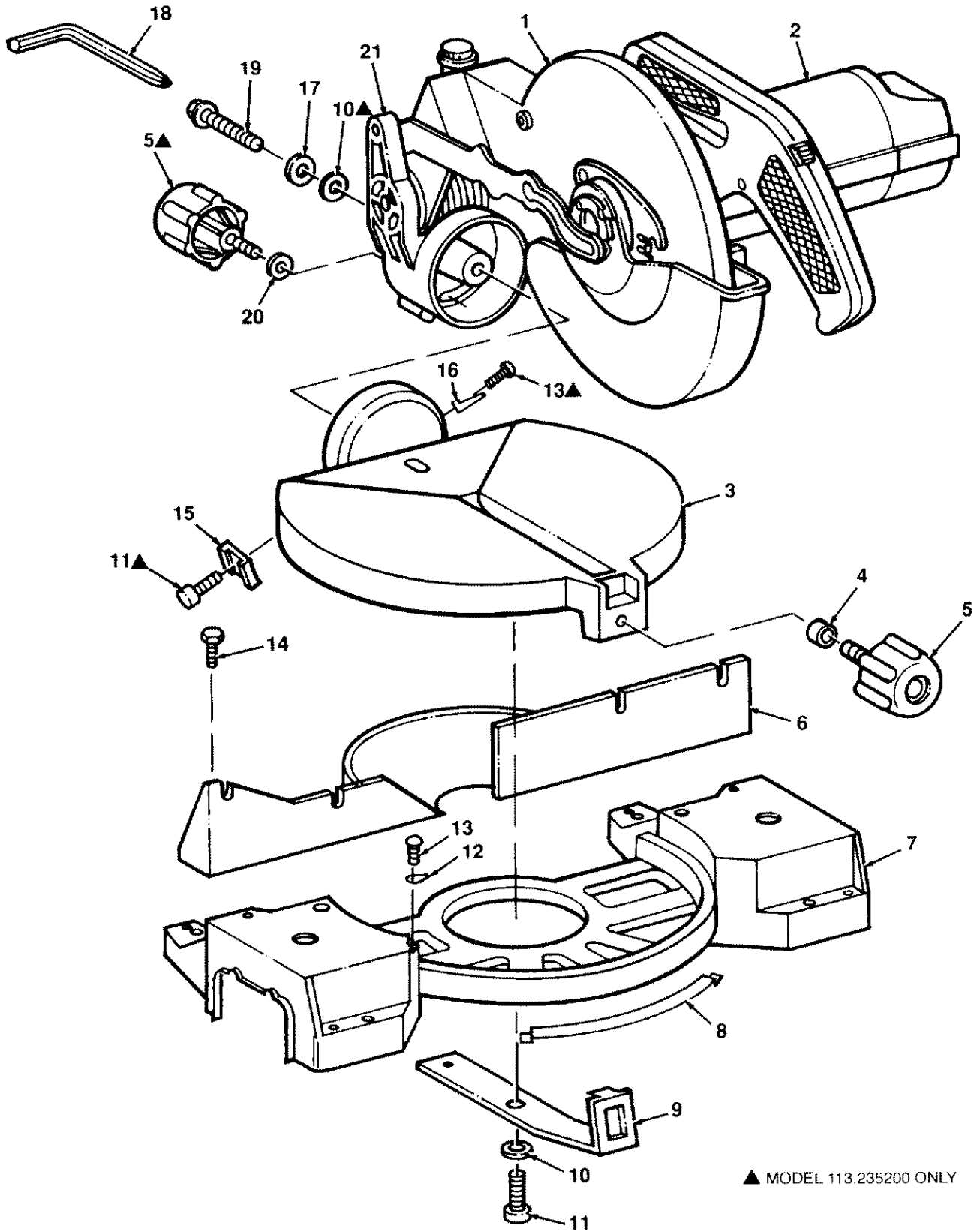

▲ MODEL 113.235200 ONLY



Repair Parts

PARTS LIST FOR CRAFTSMAN 10" MITER SAWS MODEL NO. 113.235200 AND 113.235100

FIGURE 1

Always order by Part Number — Not by Key Number

Key No.	Part No.	Description
1	See Fig 4	Blade Guard Asm.
2	See Fig 2	Motor Asm.
3	823234	▲ Table
	823230	■ Table (not shown)
4	823296	Foot Locking
5	823313	▲ Knob
6	823236	▲ Fence
	823232	■ Fence (not shown)
7	823228	Base
8	823295	Shim Table
9	823297	Spring Index
10	805553-4	▲ Washer 21/64 x 9/16 x 3/64
11	9421621	▲ Scr Soc Cap 5/16 - 18 x 5/8
12	38724	Pointer

Key No.	Part No.	Description
13	436594	Screw Pan Hd Type "T" 8-32 x 5/16
14	9416630	Screw Hex Type "T" 5/16-18 x 1
15	823326	▲ Stop Bevel
16	823327	▲ Indicator Bevel
17	821421-6	▲ O-Ring
18	823314	Wrench Combination
19	9416187	▲ Screw Hex Type "T" 5/16-18 x 3/4
20	60039	▲ Washer .380 x 47/64 x 1/16
21	See Fig 3	Pivot Asm.
—	SP5763	Owners Manual (not illustrated)

* Standard Hardware Item — May Be Purchased Locally.

▲ Model 113.235200 Only

■ Model 113.235100 Only

▲ WARNING: These items are important to the safety of this tool. Do not substitute common parts.

Repair Parts

PARTS LIST FOR CRAFTSMAN 10" MITER SAWS MODEL NO. 113.235200 AND 113.235100

FIGURE 2—ARM AND MOTOR ASSEMBLY

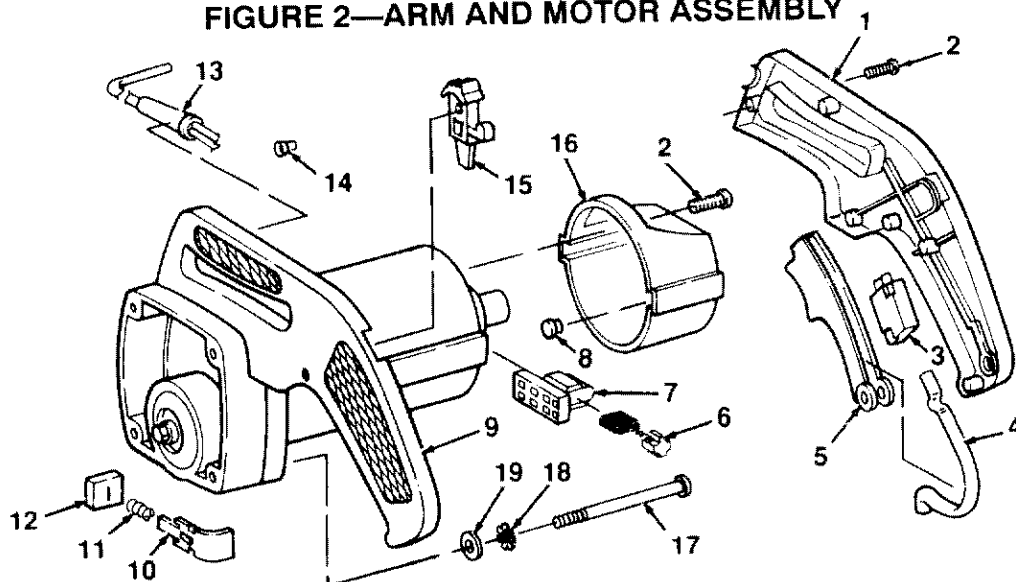

WARNING: For your safety, this miter saw is specially insulated. To avoid electrical shock, fire or injury, use only parts identical to those identified in the parts list. Reassemble exactly as originally assembled.

Always order by Part Number — Not by Key Number

Key No.	Part No.	Description
1	823290	Handle Right Half
2	808380-5	Screw Pan Cr #8 Plastite
3	823286	▲ Switch SPDT
4	823289	Spring Trigger
5	823287	Trigger
6	823281	▲ Brush
7	823277	▲ Holder Brush
8	354653	Bumper
9	823955	▲ Motor/Gear Box
9	823841	■ Motor/Gear Box
10	823323	▲ Lock Arbor
11	823322	▲ Spring Arbor Lock Seal
12	823417	Seal
13	823284	▲ Cord W/Plug
13	823284-1	■ Cord W/Plug
14	803709-1	Connector Wire
15	823288	▲ Button Lock
16	823283	Cap Motor Housing
17	808277-11	Screw Pn. Hd. 10-32 x 2-1/4
18	STD551210	* Lockwasher Ext #10
19	STD551010	• Washer 13/64 x 3/8 x 1/32

▲ Model 113.235200 Only ■ Model 113.235100 Only

▲ **WARNING:** These items are important to the safety of this tool. Do not substitute common parts.

‡ **CAUTION:** See Mechanical Assembly Caution below.

• **WARNING:** Any attempt to repair or replace electrical parts on this unit may create a Hazard unless repair is done by a qualified service technician. Repair service is available at your nearest Sears store.

PARTS LIST FOR CRAFTSMAN 10" MITER SAWS MODEL NO. 113.235200 AND 113.235100

FIGURE 3—PIVOT ASSEMBLY

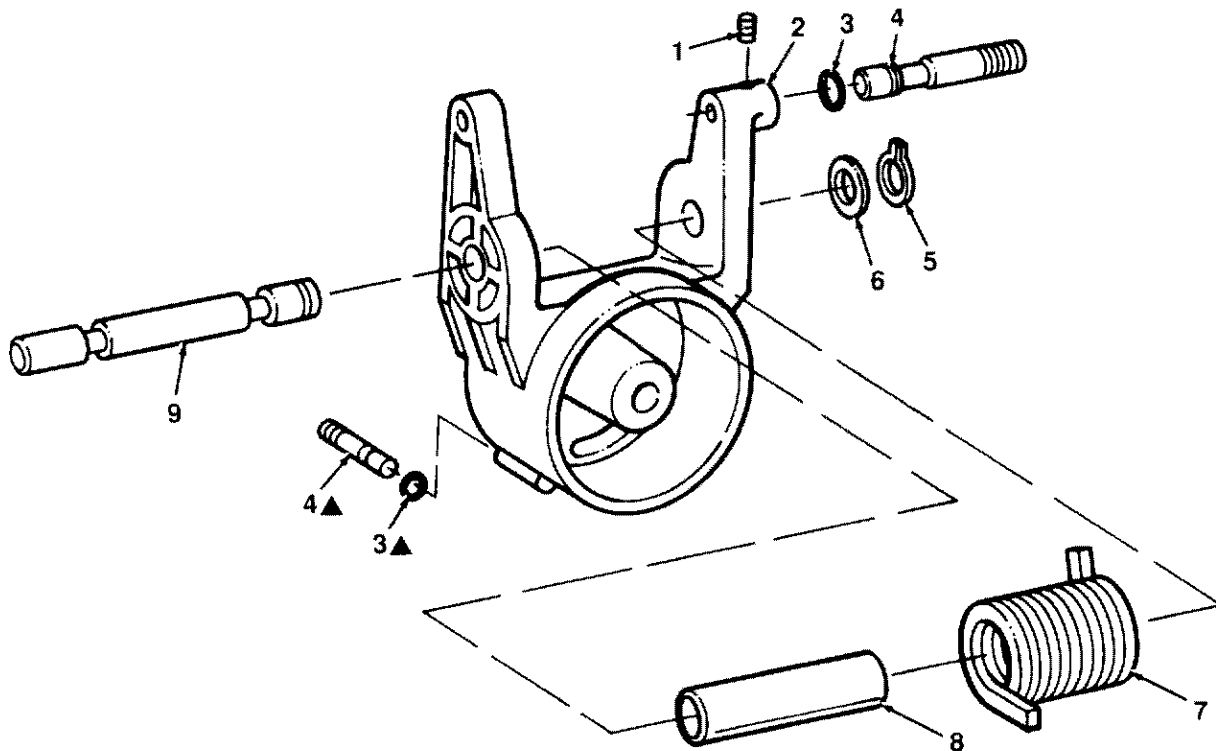

Always order by Part Number — Not by Key Number

Key No.	Part No.	Description
1	803309-2	Screw Set Hex Soc. Locking 10-32 x 3/8
2	823324	▲ Pivot
3	821421-2	O-Ring
4	823302	Shaft Stop
5	805606	Ring Retaining
6	803899-5	Washer Thrust
7	823328	▲ • ‡ Spring Torsion
8	823298	Spacer Spring
9	823301	Shaft Pivot

*Standard Hardware Item — May Be Purchased Locally.

▲ Model 113.235200 Only

■ Model 113.235100 Only

‡ CAUTION: See Mechanical Assembly Caution on page 31.

• WARNING: Uncontrolled spring release or misinstallation of these parts may create a Hazard unless repair is done by a qualified service technician. Repair service is available at your nearest Sears store.

▲ WARNING: These items are important to the safety of this tool. Do not substitute common parts.

PARTS LIST FOR CRAFTSMAN 10" MITER SAWS
MODEL NO. 113.235200 AND 113.235100

FIGURE 4

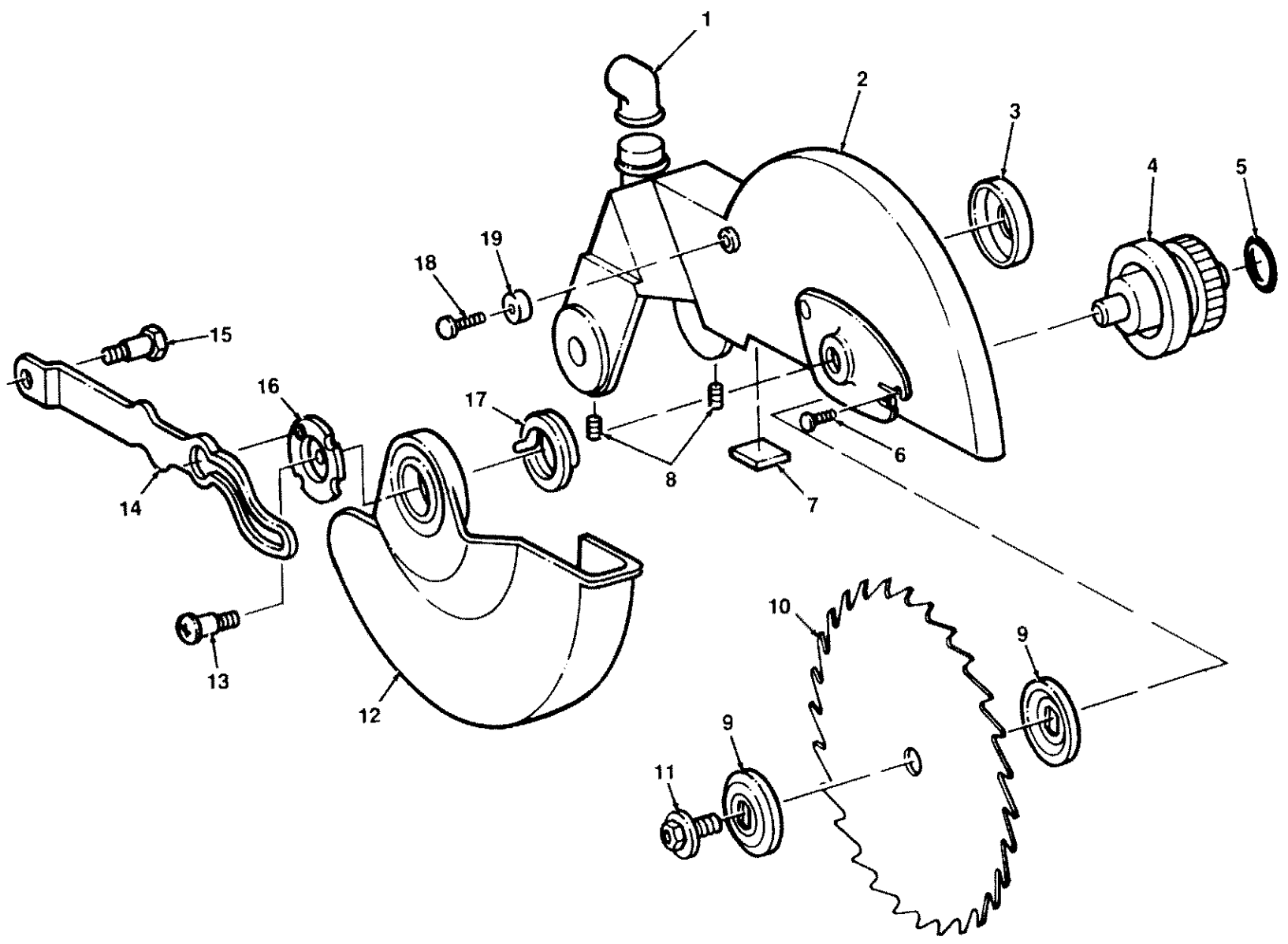

30



**PARTS LIST FOR CRAFTSMAN 10" MITER SAWS
MODEL NO. 113.235200 AND 113.235100**

FIGURE 4

Key No.	Part No.	Description
1	820536	Dust Elbow
2	823956	Arm/Guard
3	823300	Washer Cup
4	823251	Arbor
5	821421-3	Ring "O"
6	STD601105	* Screw Pan Cr Ty "T" 10-32 x 1/2
7	823307	Bumper Guard
8	60288	Screw Lock Set 1/4-20 x 3/8
9	823303	▲▲ Collar Blade
10	9-32126	▲† Blade Saw
10	9-32138	▲▲ ■† Blade Saw
11	823304	Screw Blade
12	823291	▲▲ ‡ Guard Lower
13	821521-2	Screw Shoulder
14	823305	Link Actuator
15	821521-1	Screw Shoulder
16	823840	▲▲ Retainer Guard
17	823292	• ‡ Spring Guard
18	821521	Screw Shoulder
19	823306	Bearing Cam

† Stock Item - May be secured through the hardware department of most Sears retail stores.

▲ Model 113.235200 Only

■ Model 113.235100 Only

▲▲ **WARNING:** These items are important to the safety of this tool. Do not substitute common parts.

‡ **CAUTION:** See Mechanical Assembly Caution below.

• **WARNING:** Uncontrolled spring release or misinstallation of these parts may create a Hazard unless repair is done by a qualified service technician. Repair service is available at your nearest Sears store.

CAUTION: Mechanical Assembly, to qualified service technician.

1. Wear approved eye protection when working with coil spring including spring, arbor lock 823322.
2. Incorrect re-assembly of torsion spring 823328 can cause an unsafe condition because cutting head fails to rise fully to stop, or because spring fails through over-stress.
3. Improper reassembly of mechanisms controlling movement of lower guard 823292 can cause an unsafe condition because guard fails to operate freely as cutting head is moved up and down.



SEARS

owner's manual

SERVICE

MODEL NO. 113.235200

COMPOUND MITER SAW

113.235100

NON-COMPOUND MITER
SAW

**IF YOU NEED REPAIR
SERVICE OR PARTS:**

For repair service, call this toll
free number:

**1-800-4-REPAIR
(1-800-473-7247)**

For replacement parts
information and ordering, call
this toll free number:

10 INCH MITER SAW

Now that you have purchased your 10 inch Miter Saw, should a need ever exist for repair parts or service simply contact any Sears Service Center and most Sears, Roebuck and Co. stores. Be sure to provide all pertinent facts when you call or visit.

The model number of your 10 inch Miter Saw will be found on a plate attached to your saw.

WHEN ORDERING REPAIR PARTS, ALWAYS GIVE THE FOLLOWING INFORMATION:

PART NUMBER	PART DESCRIPTION
MODEL NUMBER	NAME OF ITEM
113.235200	10" COMPOUND MITER SAW
113.235100	10" NON-COMPOUND MITER SAW

All parts listed may be ordered from any Sears Service Center and most Sears stores. If the parts you need are not stocked locally, your order will be electronically transmitted to a Sears Repair Parts Distribution Center for handling.

Sears, Roebuck and Co., Hoffman Estates, IL 60179 U.S.A.