



**MODELS**

CHI643BA, CHI743BA, SHI643BA

INDUCTION COOKTOPS

User and Installation Manual



## CONGRATULATIONS

Congratulations and thank you for choosing our Induction Cooktop. We are sure you will find your new appliance a pleasure to use and a great asset to your cooking. Before you use the appliance, we recommend that you read through the whole user manual which provides a description of the product and its functions.

To avoid the risks that are always present when you use a cooking appliance, it is important that the appliance is installed correctly and that you read the safety instructions carefully to avoid misuse and hazards. For future reference, please store this booklet in a safe place.

## CONDITIONS OF USE

This appliance is intended to be used in household and similar applications such as:

- Staff kitchen areas in shops, offices and other working environments
- Farm houses
- By clients in hotels, motels and other residential type environments
- Bed and breakfast type environments

### Record model and serial number here:

Model: .....

Serial number: .....

The symbols you will see in this booklet have these meanings:



### warning

Indicates information concerning your personal safety



### caution

Indicates information on how to avoid damaging the appliance



### tips & information

Indicates tips and information about use of the appliance



### environmental tips

Indicates tips and information about economical and ecological use of the appliance



### tips & information

#### Important – check for any damage or marks

If you find the appliance is damaged or marked, you must report it within 7 days if you wish to claim for damage/marks under the manufacturer's warranty. This does not affect your statutory rights.



### environmental tips

#### Information on disposal for users

- Most of the packing materials are recyclable. Please dispose of those materials by contacting your local authorities and ask for the correct method of disposal.

## CONTENTS

<b>General safety</b> .....	<b>3</b>
<b>Installation instructions</b> .....	<b>4</b>
<b>Assembly</b> .....	<b>5</b>
<b>Product description</b> .....	<b>7</b>
<b>Operating instructions</b> .....	<b>8</b>
<b>Helpful hints and tips</b> .....	<b>9</b>
<b>Care and cleaning</b> .....	<b>10</b>
<b>Environment concerns</b> .....	<b>11</b>
<b>Warranty</b> .....	<b>12</b>

**Subject to change without notice.**

# general safety

## Safety information

For your safety and correct operation of the appliance, read this manual carefully before the installation and use. Always keep these instructions with the appliance if you move or sell it. The users must fully know the operation and safety functions of the appliance.

## Children and vulnerable people safety

### warning

Do not let persons, children included, with reduced physical sensory, reduced mental functions or lack of experience and knowledge to use the appliance. They must have supervision or instruction for the operation of the appliance by a person who is responsible for their safety.

- Keep all packaging away from children. There is the risk of suffocation or injury.
- Keep the children away from the appliance during and after the operation, until the appliance is cold.

## Safety during operation

- Remove all packaging, stickers and layers from the appliance before the first use.
- Set the cooking zones to "off" after each use.
- The risk of burns! Do not put objects made of metal, for example cutlery or saucepan lids, on the surface that you cook. They can become hot.
- The users with an implanted pacemaker must keep their upper body minimum 30cm from induction cooking zones that are activated.

### warning

Fire risk! Fats and oils can become hot very quickly with ignition.

## Correct operation

- The appliance is only for domestic use.
- Do not use the appliance as a work or a storage surface.
- Do not put or keep flammable liquids and materials, easy fusible objects (made of plastic or aluminium) on or near the appliance.
- Be careful when you connect the appliance to the near sockets. Other than the connection point in the terminal block, do not let the electrical supply cord touch the appliance or hot cookware. Ensure electrical supply cord is not tangled.

## How to prevent damage to the appliance.

- If objects or cookware fall on the glass, the surface can be damaged.
- Cookware made of cast iron, cast aluminium or with damaged bottoms can scratch of the glass. Do not move them on the surface.
- Do not let cookware boil dry to prevent the damage to cookware and glass .
- Do not use the cooking zones with empty cookware or without cookware.
- Do not put aluminium foil on the appliance.
- Make sure that the airflow space of 5mm between the worktop and front of the unit below it stays opened.

### warning

If there is a crack on the surface, disconnect power supply to prevent the electrical shock.

# installation instructions

## **i** tips & information

Before the installation, note down the serial number from the rating plate. The rating plate of the appliance is on its lower casing.

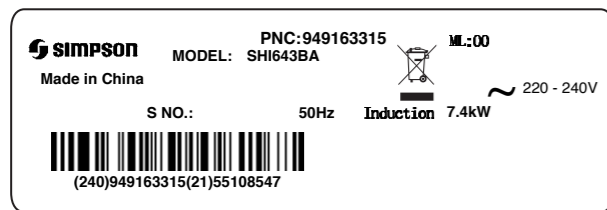
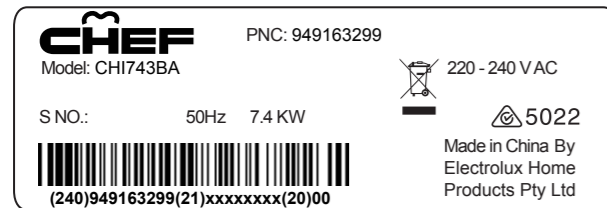
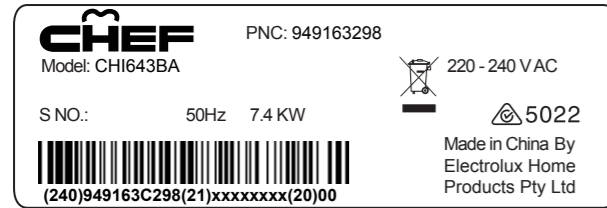

## The Safety Instructions

### **warning**

You must read these!

- Make sure that the appliance has not been damaged in transportation. Do not connect a damaged appliance. If it is necessary, speak to the supplier.
- Only an authorized servicing technician can install, connect or repair this appliance. Use only original spare parts.
- Only use the built-in appliances after you assemble the appliance into correct built-in units and work surfaces that align to the standards.
- Do not change the specification of this appliance. Due to a risk of injury and damage.
- Fully obey the laws, ordinances, directives and standards in the country where you use the appliance (safety regulations, recycling regulations, electrical safety rules etc).
- Keep the minimum distances to other appliances and units.
- Make sure that the ventilation space of 5mm, under the benchtop and directly in front of the appliance is free. The warranty does not cover damages caused by lack of adequate ventilation.
- Install shock protection, for example install the drawers only with a protective floor directly below the appliance.
- Do not use an external timer or a separate remote-control system to operate the appliance.

- Set the cooking zone to “off” after each use. Do not rely on the pan detector.
- Keep the cut surfaces of the worktop safe from moisture with a correct sealant.
- Seal the appliance to the worktop with no space between with a correct sealant.
- Keep the bottom of the appliance safe from steam and moisture, e.g. from a dishwasher or oven.
- Do not install the appliance adjacent to doors and below windows, due to risk of cookware being pushed off hot appliance.

### **warning**

Risk of injury from electrical current. Carefully obey the instructions for electrical connections.

- Make electrical mains terminal free of voltage.
- Install correctly to give shock protection.
- Loose and incorrect plug and socket connections can make the terminal become too hot.
- A qualified electrician must install the connections in the clamps correctly.
- Use a strain relief clamp on cable.
- Use the correct mains cable of type H05BB-F Tmax 90°C (or higher) for a single phase or two phase connection.
- Replace the damaged mains cable with a special cable (type H05BB-F Tmax 90°C; or higher). Speak to our Customer Care team.

The appliance must have the electrical installation which lets you disconnect the appliance from the mains at all poles with a contact opening width of minimum 3mm. You must have correct devices to isolate: line protecting cut-outs, fuses (screw type fuses removed from the holder), earth leakage trips and contactors.

# assembly

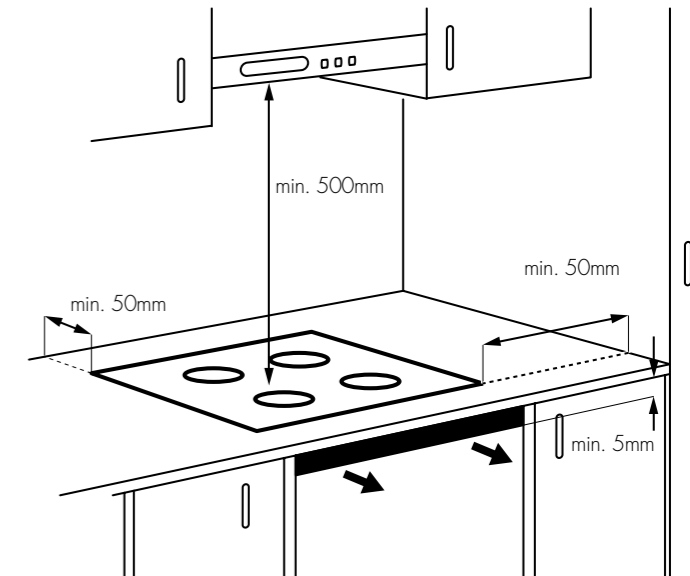
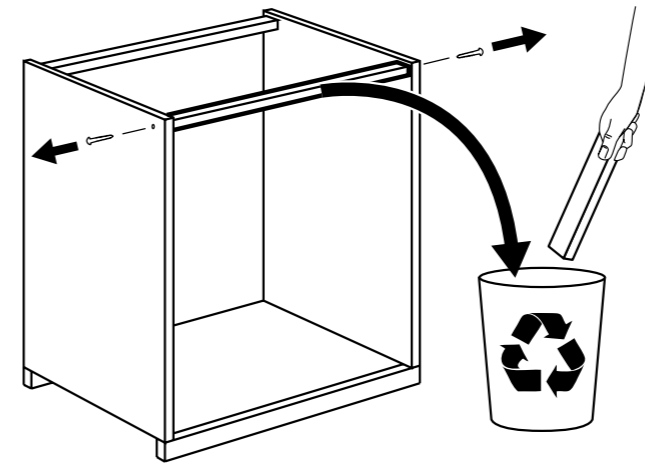

Make sure that a ventilation space of 5mm directly below the benchtop is included in the installation and kept free during use of the appliance. The warranty does not cover functional failures caused by the lack of an adequate ventilation space.

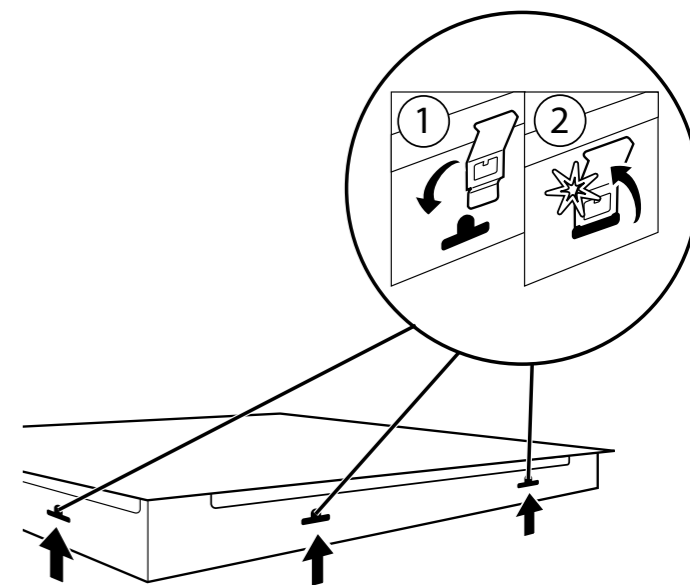
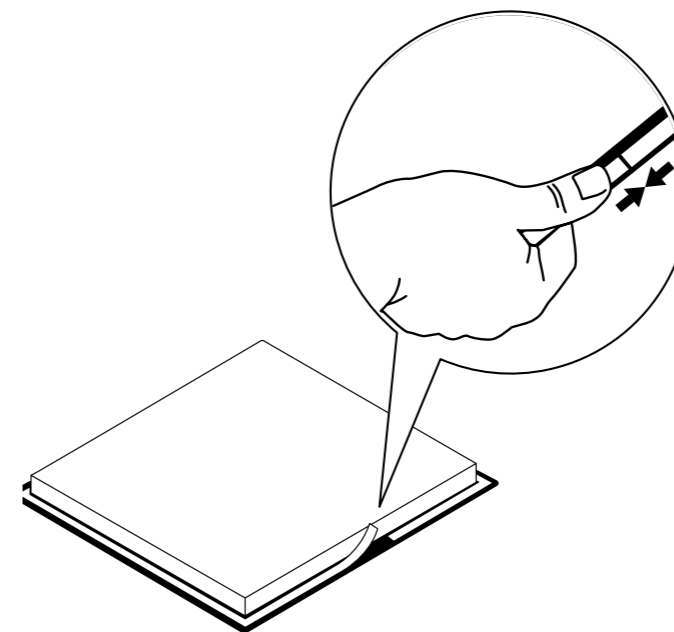

# assembly

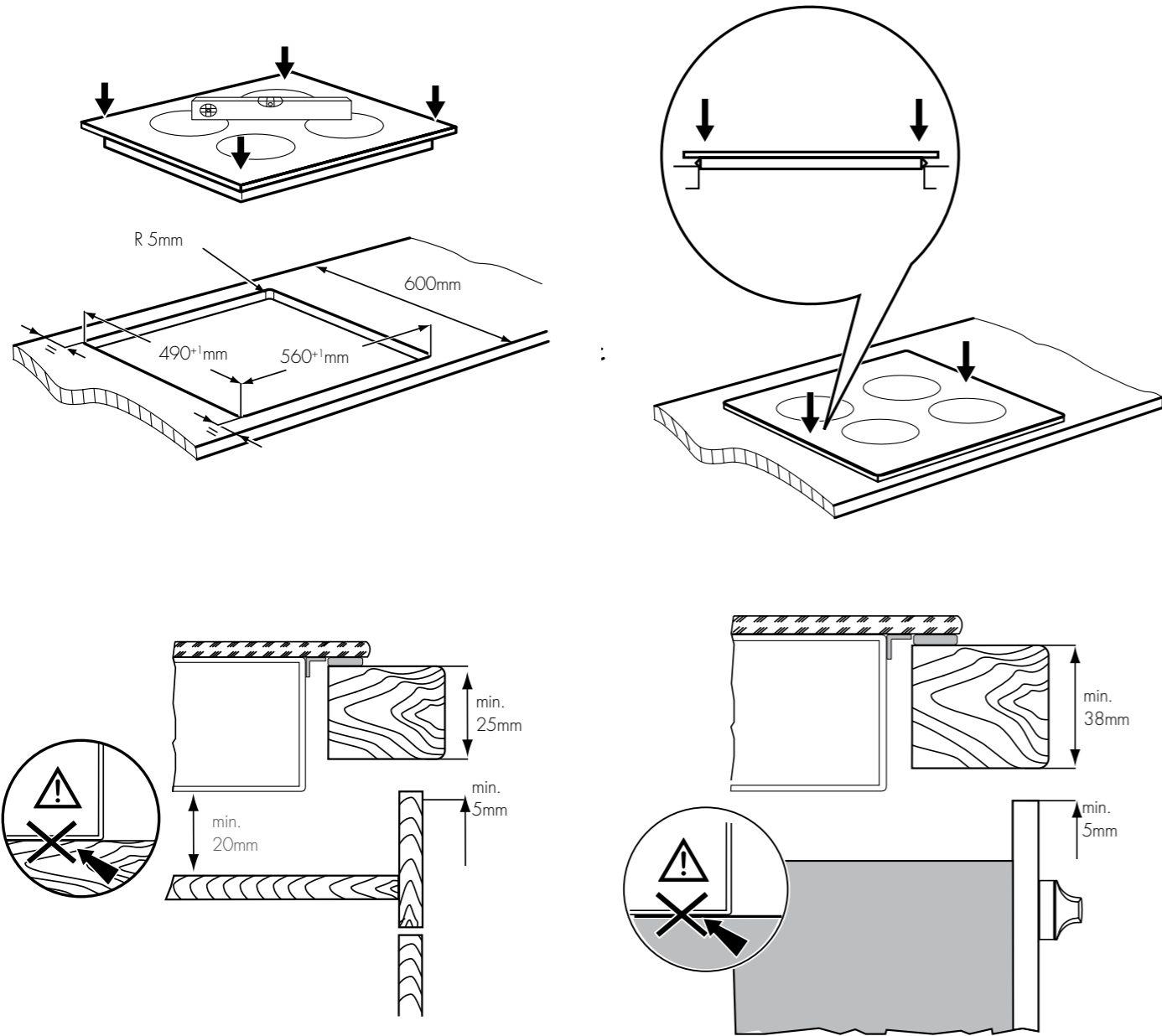

Make sure that a ventilation space of 5mm directly below the benchtop is included in the installation and kept free during use of the appliance. The warranty does not cover functional failures caused by the lack of an adequate ventilation space.

# product description

## General overview

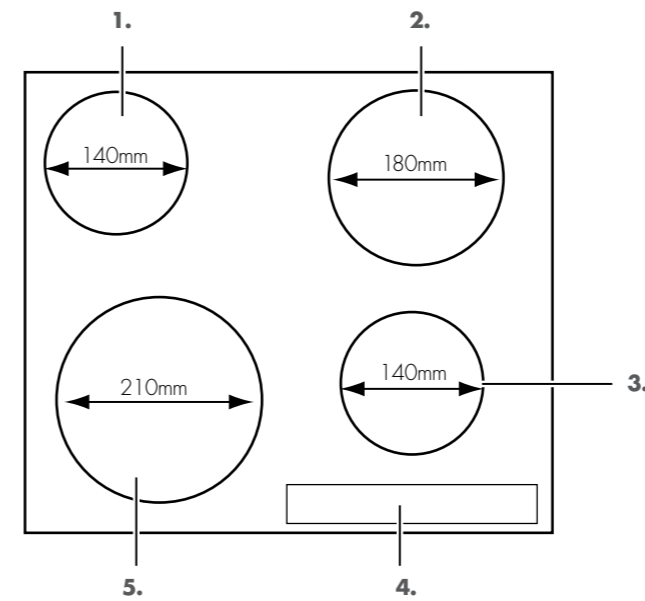

1. Induction cooking zone 1400W, with Power function 2500W (minimum cookware diameter=125mm)
2. Induction cooking zone 1800W, with Power function 2800W (minimum cookware diameter=145mm)
3. Induction cooking zone 1400W, with Power function 2500W (minimum cookware diameter=125mm)
4. Induction cooking zone 2300W, with Power function 3200W (minimum cookware diameter=180mm)

## Control panel layout

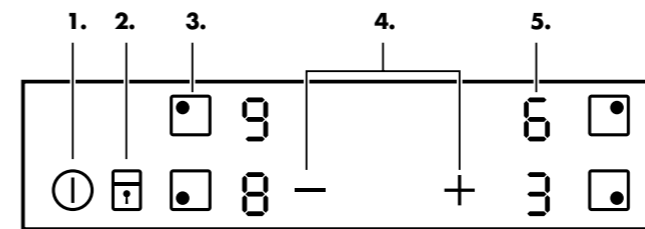

## Operating the sensor field

	Sensor field	Function
1.	ⓘ	Activates and deactivates the appliance
2.	🔒	Locks/unlocks the control panel
3.	●	Activates the cooking zone
4.	- / +	Increases and decreases the heat settings
5.	Heat setting display	Shows the heat setting

## Heat setting displays

Display	Description
0	The cooking zone is deactivated
1 - 9	The cooking zone is in operation
F	The cookware is incorrect or too small, or there is no cookware on the cooking zone
L	The lock/the child safety device is in operation
P	The power function is in operation
E	There is a malfunction
H	A cooking zone is still hot (residual heat)
-	The automatic switch off is in operation

## Residual heat indicator

**⚠ warning**

**H** The risk of burns from residual heat!

The induction cooking zones make the heat necessary for cooking directly to the bottom of the cookware. The ceramic glass conducts the heat into the cookware.

# operating instructions

## Activation and deactivation

Touch **1** for 1 second to activate or deactivate the appliance.

## Automatic switch off

The function deactivates the appliance automatically if:

- All cooking zones are deactivated **0**.
- You do not set the heat setting after you activate the appliance.

- You spill something or put something on the control panel for more than 10 seconds, (a pan, a cloth etc.) Remove the object or clean the control panel.
- The appliance becomes too hot (e.g. when, a saucepan boils dry). Before you use the appliance again, the cooking zone must be cool.
- If you use incorrect cookware. The symbol **F** comes on and the cooking zone deactivates automatically after 2 minutes.
- If you do not deactivate a cooking zone or change a heat setting. After some time, **□** comes on and the appliance deactivates. Refer to table.

## The times of Automatic Switch Off

The heat setting	<b>1</b> – <b>2</b>	<b>3</b> – <b>4</b>	<b>5</b>	<b>6</b> – <b>9</b>
The cooking zone deactivates after	6 hours	5 hours	4 hours	1.5 hours

## The cooking zone selection

To set the cooking zone touch the sensor field **□** related with the cooking zone. The display shows the selection by the dot adjacent to the heat setting indication (**0**).

## The heat setting

Set the cooking zone. Press **+** to increase the heat setting. Press **-** to decrease the heat setting. The display shows the heat setting. Touch **+** and **-** at the same time to deactivate the cooking zone.

## Power function

The power function increases power to the induction cooking zones. You can activate the Power function for a maximum of 10 minutes. After that the induction cooking zone automatically sets back to highest setting.

To activate the function:

1. Set the cooking zone.
2. Set the zone for the maximum heat setting.
3. Press **+** and **P** comes on. To deactivate the function press **-**.

## Power management

The power management divides the power between two cooking zones in a pair (Refer to the illustration). The power function increases the power to the maximum level for one cooking zone in the pair. Automatically decreases the power in the second cooking zone to a power level. The display for the reduced zone change between two levels.

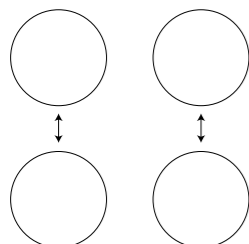

## Lock

When the cooking zones operate you can lock the control panel, but not **1**. It prevents an accidental change of the heat setting. First set the heat setting. To start this function touch **L**. The **L** symbol comes on for 4 seconds.

To stop this function touch **L**. The heat setting that you set before comes on. When you switch off the cooktop, you also stop this function.

## The child safety device

This function prevents an accidental operation of the appliance.

To activate the child safety device:

- Activate the appliance with **1**. Do not set the heat settings.
- Touch **L** for 4 seconds. The symbol **L** comes on.
- Deactivate the appliance with **1**.

To deactivate the child safety device:

- Activate the appliance with **1**. Do not set the heat settings. Touch **L** for 4 seconds. The symbol **L** comes on.
- Deactivate the appliance with **1**.

To override the child safety device for only one cooking time:

- Activate the appliance with **1**. The symbol **L** comes on.
- Touch **L** for 4 seconds. Set the heat setting for 10 seconds. You can operate the appliance.
- When you deactivate the appliance with **1**, the child safety device operates again.

# helpful hints and tips

## **i** tips & information

Use the correct cookware induction cooktop.

## Cookware for induction cooking zones

**Important!** For induction cooking zones a strong electro-magnetic field creates the heat in the cookware very quickly.

## Cookware material

- Correct: cast iron, steel, enamelled steel, stainless steel, the bottom made of multilayer (with correct mark from a manufacturer).
- Incorrect: aluminium, copper, brass, glass, ceramic, porcelain.

## Cookware is correct for an induction hob if:

- Water boils very quickly on a zone set to the highest heat setting.
- A magnet pulls to the bottom of the cookware.

The bottom of the cookware must be as thick and flat as possible. Cookware dimensions: induction cooking zones adapt to the dimension of the bottom of the cookware automatically to some limit.

## The noises during operation

If you can hear:

- A cracking noise: cookware is made of different materials.
- Whistle sound: one or more cooking zones with high power levels and the cookware is made of different materials.
- Humming: high power levels in use.
- Clicking: electric switching occurs.
- Hissing, buzzing: the fan is in operation.

The noises are normal and do not refer to appliance malfunction. If unfamiliar with induction units please first compare the operating sounds of a demonstration model at your retailer before calling service. If a service call is placed and the sounds are normal you will be charged for the visit.

## environmental tips

### Energy saving

- If it is possible, always put the lids on the cookware.
- Put cookware on a cooking zone before you start it.

## The Examples of cooking applications

The data in the table is for guidance only.

Heat setting	Use	Time	Hint
1	Keep food warm	As required	Keep cookware covered
1–2	Hollandaise sauce, melt: butter, chocolate and gelatine	5–25mins	Stir from time to time
1–2	Solidify: fluffy omelettes and baked eggs	10–40mins	Keep cookware covered
2–3	Simmer rice and milk based dishes and heating up ready-cooked meals	25–50min	Don't allow to dry out
3–4	Steam vegetables, fish and meat	20–45min	Add a tablespoon of water
4–5	Steam potatoes	20–60min	Use no more than 1/4 cup of water and 750g of potatoes
4–5	Cook larger quantities of food, stews and soups	60–150mins	Use up to 3 cups of water
6–7	Gentle fry: escalope, veal cordon bleu, cutlets, rissoles, sausages, liver, roux, eggs, pancakes and donuts	As required	Turn half way through cook
7–8	Heavy fry, hash browns, loin steaks, steaks	5–15mins	Turn half way through cook
9	Boil large quantities of water, cook pasta, sear meat (goulash, pot roast), deep-fry chips	–	–

# care and cleaning

Clean the appliance after each use. Always use cookware with clean bottom.









## warning

Sharp objects and abrasive cleaning agents can cause damage to the appliance. For your safety, do not clean the appliance with steam cleaners or high-pressure cleaners.

## tips & information

Scratches or dark stains on the glass ceramic cause no effect on how the appliance operates.

### How to resolve problems with your cooktop

Problem	Possible cause and remedy
You can't activate the cooktop or operate it.	<ul style="list-style-type: none"> <li>• Activate the appliance again and set the heat setting in 10 seconds.</li> <li>• You touched 2 or more sensor fields at the same time. Only touch one sensor field.</li> <li>• There is water or fat stains on the control panel. Clean the control panel.</li> </ul>
The cooktop deactivates.	An object has been placed on the  button. Remove the object from the sensor field.
The residual heat indicator does not come on.	The cooking zone is not hot because it operated only for a short time. If the cooking zone is hot, contact our Customer Care team.
The sensor fields become hot.	The cookware is too large or you put it too near to the controls. Put large cookware on the rear cooking zones if it is necessary.
 comes on	The Automatic Switch Off is in operation. Deactivate the appliance and activate it again.
 comes on	<ul style="list-style-type: none"> <li>• No cookware on the cooking zone. Put cookware on the cooking zone.</li> <li>• Not correct cookware. Use the correct cookware.</li> <li>• The diameter of the bottom of the cookware is too small for the cooking zone. Move cookware to a smaller cooking zone.</li> </ul>
 and number comes on	There is an error in the appliance. Disconnect the appliance from the electrical supply for some time. Disconnect the fuse from the electrical system of the house. Connect again. If  comes on again, contact our Customer Care team.
 comes on	The Automatic Switch Off operates when the cookware on the appliance boils dry. Deactivate the appliance. Remove the hot cookware. After approximately 30 seconds, activate the cooking zone again.  will disappear from the display but the residual heat indicator will be shown until the cookware and appliance has sufficiently cooled down. Refer to the Cookware section for correct cooking temperatures.
Red rings, limescale or water rings, shiny metallic or other discolouration, scratches/shadows, bubbles or other miscellaneous marks or stains on ceramic glass cooktop surface.	Cooktop surface has not been cleaned correctly. Cleaning/maintenance of the cooktop surface is not covered under warranty. If a service call is placed to clean the cooktop you will be charged for the visit. Use a ceramic glass cleaner such as Cerapol.
Pitting of ceramic glass surface.	Spills of liquid with high sugar content. These types of spills must be removed immediately with a special scraper for the glass. If not permanent damage to the cooktop glass can occur which is not covered under warranty.
The heat setting changes between two levels.	The power management is activated. Refer to 'Power management'
 comes on	The Child Safety Lock device or the Lock function operates. Refer to chapter 'Operating instructions'.

If you tried the above solutions and cannot repair the problem, speak to your dealer or our Customer Care team. Give the data from the rating plate, three digit letter code for the ceramic glass (it is in the corner of the glass surface) and an error message that comes on. Make sure, you operated the

### To remove the dirt:

1. • Remove immediately: melted plastic, plastic foil, and food with sugar. If not, the dirt can cause damage to the appliance. Use a special scraper for the glass. Put the scraper on the glass surface at an acute angle and move the blade on the surface.
  - Remove after the appliance is sufficiently cool: limescale rings, water rings, fat stains, shiny metallic discolourations. Use a special cleaning agent for glass ceramic or stainless steel.
2. Clean the appliance with a moist cloth and some detergent.
3. At the end rub the appliance dry with a clean cloth.

appliance correctly. If not the servicing by a customer service technician or dealer will not be free of charge, also during the warranty period. The instructions about the customer service and conditions of guarantee are in the guarantee booklet.

# environmental concerns

The symbol  on the product or on its packaging indicates that this product may not be treated as household waste. Instead it should be taken to the appropriate collection point for the recycling of electrical and electronic equipment.

By ensuring this product is disposed of correctly, you will help prevent potential negative consequences for the environment and human health, which could otherwise be caused by inappropriate waste handling of this product.

For more detailed information about recycling of this product, please contact your local council, your household waste disposal service or the shop where you purchased the product.

## environmental tips

### Packaging material

The packaging materials are friendly to the environment and can be recycled. The plastic components are identified by marking: >PE<, >PS<, etc. Discard the packaging materials as household waste at the waste disposal.



**Electrolux Warranty**  
 FOR SALES IN AUSTRALIA AND NEW ZEALAND  
 APPLIANCE: BUILT-IN OVEN, COOKTOP  
 AND FREESTANDING COOKERS

**This document sets out the terms and conditions of the product warranties for Electrolux Appliances. It is an important document. Please keep it with your proof of purchase documents in a safe place for future reference should you require service for your Appliance.**

1. In this warranty:
  - (a) 'acceptable quality' as referred to in clause 10 of this warranty has the same meaning referred to in the ACL;
  - (b) 'ACL' means Schedule 2 to the Competition and Consumer Act 2010;
  - (c) 'Appliance' means any Electrolux product purchased by you and accompanied by this document;
  - (d) 'ASC' means Electrolux authorised service centres;
  - (e) 'Electrolux' means Electrolux Home Products Pty Ltd of 163 O'Riordan Street, Mascot NSW 2020, ABN 51 004 762 341 in respect of Appliances purchased in Australia and Electrolux (NZ) Limited (collectively 'Electrolux') of 3-5 Niall Burgess Road, Mount Wellington, in respect of Appliances purchased in New Zealand;
  - (f) 'major failure' as referred to in clause 10 of this warranty has the same meaning referred to in the ACL and includes a situation when an Appliance cannot be repaired or it is uneconomic for Electrolux, at its discretion, to repair an Appliance during the Warranty Period;
  - (g) 'Warranty Period' means the Appliance is warranted against manufacturing defects in Australia for 24 months and in New Zealand for 24 months, following the date of original purchase of the Appliance;
  - (h) 'you' means the purchaser of the Appliance not having purchased the Appliance for re-sale, and 'your' has a corresponding meaning.
2. This warranty only applies to Appliances purchased and used in Australia or New Zealand and used in normal domestic applications and is in addition to (and does not exclude, restrict, or modify in any way) any non-excludable statutory warranties in Australia or New Zealand.
3. During the Warranty Period Electrolux or its ASC will, at no extra charge if your Appliance is readily accessible for service, without special equipment and subject to these terms and conditions, repair or replace any parts which it considers to be defective. Electrolux or its ASC may use remanufactured parts to repair your Appliance. You agree that any replaced Appliances or parts become the property of Electrolux. This warranty does not apply to light globes, batteries, filters or similar perishable parts.
4. Parts and Appliances not supplied by Electrolux are not covered by this warranty.
5. To the extent permitted by law, you will bear the cost of transportation, travel and delivery of the Appliance to and from Electrolux or its ASC. If you reside outside of the service area, you will bear the cost of:
  - (a) travel of an authorised representative;
  - (b) transportation and delivery of the Appliance to and from Electrolux or its ASC.

In all instances, unless the Appliance is transported by Electrolux or an Electrolux authorised representative, the Appliance is transported at the owner's cost and risk while in transit to and from Electrolux or its ASC.
6. Proof of purchase is required before you can make a claim under this warranty.

7. You may not make a claim under this warranty unless the defect claimed is due to faulty or defective parts or workmanship. Electrolux is not liable in the following situations (which are not exhaustive):
  - (a) the Appliance is damaged by:
    - (i) accident
    - (ii) misuse or abuse, including failure to properly maintain or service
    - (iii) normal wear and tear
    - (iv) power surges, electrical storm damage or incorrect power supply
    - (v) incomplete or improper installation
    - (vi) incorrect, improper or inappropriate operation
    - (vii) insect or vermin infestation
    - (viii) failure to comply with any additional instructions supplied with the Appliance;
  - (b) the Appliance is modified without authority from Electrolux in writing;
  - (c) the Appliance's serial number or warranty seal has been removed or defaced;
  - (d) the Appliance was serviced or repaired by anyone other than Electrolux, an authorised repairer or ASC.
8. This warranty, the contract to which it relates and the relationship between you and Electrolux are governed by the law applicable where the Appliance was purchased. Where the Appliance was purchased in New Zealand for commercial purposes the Consumer Guarantee Act does not apply.
9. To the extent permitted by law and subject to your non-excludable statutory rights and warranties, Electrolux excludes all warranties and liabilities (other than as contained in this document) including liability for any loss or damage whether direct or indirect arising from your purchase, use or non use of the Appliance.
10. For Appliances and services provided by Electrolux in Australia, the Appliances come with a guarantee by Electrolux that cannot be excluded under the ACL. You are entitled to a replacement or refund for a major failure and for compensation for any other reasonably foreseeable loss or damage. You are also entitled to have the Appliance repaired or replaced if the Appliance fails to be of acceptable quality and the failure does not amount to a major failure. The benefits to you given by this warranty are in addition to your other rights and remedies under a law in relation to the Appliances or services to which the warranty relates.
11. At all times during the Warranty Period, Electrolux shall, at its discretion, determine whether repair, replacement or refund will apply if an Appliance has a valid warranty claim applicable to it.
12. For Appliances and services provided by Electrolux in New Zealand, the Appliances come with a guarantee by Electrolux pursuant to the provisions of the Consumer Guarantees Act, the Sale of Goods Act and the Fair Trading Act.
13. To enquire about claiming under this warranty, please follow these steps:
  - (a) carefully check the operating instructions, user manual and the terms of this warranty;
  - (b) have the model and serial number of the Appliance available;
  - (c) have the proof of purchase (e.g. an invoice) available;
  - (d) telephone the numbers shown below.
14. You accept that if you make a warranty claim, Electrolux and its ASC may exchange information in relation to you to enable Electrolux to meet its obligations under this warranty.

**Important Notice**

Before calling for service, please ensure that the steps listed in clause 13 above have been followed.

<b>FOR SERVICE</b> or to find the address of your nearest state service centre in Australia <b>PLEASE CALL 13 13 49</b> <small>For the cost of a local call (Australia only)</small>	<b>SERVICE AUSTRALIA</b> ELECTROLUX HOME PRODUCTS electrolux.com.au	<b>FOR SPARE PARTS</b> or to find the address of your nearest state spare parts centre in Australia <b>PLEASE CALL 13 13 50</b> <small>For the cost of a local call (Australia only)</small>
<b>FOR SERVICE</b> or to find the address of your nearest authorised service centre in New Zealand <b>FREE CALL 0800 10 66 10</b> <small>(New Zealand only)</small>	<b>SERVICE NEW ZEALAND</b> ELECTROLUX (NZ) Limited electrolux.co.nz	<b>FOR SPARE PARTS</b> or to find the address of your nearest state spare parts centre in New Zealand <b>FREE CALL 0800 10 66 20</b> <small>(New Zealand only)</small>

# like to know more?

For further information on all appliances, or to obtain detailed dimension and installation information, call into your Retailer, phone or email our Customer Care team or visit our website:

## **Australia**

phone: ..... 1300 363 640  
fax: ..... 1800 350 067  
email: ..... [customercare@electrolux.com.au](mailto:customercare@electrolux.com.au)  
website ..... [chef.com.au](http://chef.com.au) (Chef models)  
..... [westinghouse.com.au](http://westinghouse.com.au) (Westinghouse models)

## **New Zealand**

phone: ..... 0800 234 234  
fax: ..... 0800 363 600  
email: ..... [customercare@electrolux.co.nz](mailto:customercare@electrolux.co.nz)  
website ..... [simpson.co.nz](http://simpson.co.nz) (Simpson models)  
..... [westinghouse.co.nz](http://westinghouse.co.nz) (Westinghouse models)

## **Top service**

Top Service encompasses the after sales service provided by The Electrolux Group to consumers including delivery, home service and spare parts.

**Chef. We are part of the Electrolux Family.**  
**To add a touch of professional inspiration to your home,**  
**visit [electrolux.com.au](http://electrolux.com.au)**

© 2016 Electrolux Home Products Pty Ltd.  
ABN 51 004 762 341  
ANC A05333001  
CMAN\_InductionCooktop\_Feb16

