

10026906 10026907

Olav

Kinderschaukel

Kids Swing

Columpio infantil

Balançoire pour enfants

Altalena per bambini

Sehr geehrter Kunde,

wir gratulieren Ihnen zum Erwerb Ihres Gerätes. Lesen Sie die folgenden Hinweise sorgfältig durch und befolgen Sie diese, um möglichen Schäden vorzubeugen. Für Schäden, die durch Missachtung der Hinweise und unsachgemäßen Gebrauch entstehen, übernehmen wir keine Haftung. Scannen Sie den folgenden QR-Code, um Zugriff auf die aktuellste Bedienungsanleitung und weitere Informationen rund um das Produkt zu erhalten.

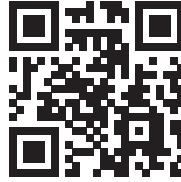

INHALTSVERZEICHNIS

Sicherheitshinweise 4
 Benötigte Werkzeuge 6
 Lieferumfang 6
 Montage 9
 Verankerung 19
 Hersteller & Importeur (UK) 21

English 23
Italiano 43
Español 63
Français 83

TECHNISCHE DATEN

Artikelnummer	10026906, 10026907
Maximal zulässiges Gesamtkörpergewicht	Bis zu 45 kg

SICHERHEITSHINWEISE

Hinweise zur Alters- und Gewichtsbeschränkung



Die Schaukel eignet sich für Kinder im Alter von 3-8 Jahren. Die Schaukel ist nicht für Kinder unter 3 Jahren geeignet, da sie sich an Kleinteilen oder den langen Seilen verletzen könnten. Die Schaukel eignet sich nicht für Erwachsene oder Kinder mit einem Gewicht von mehr als 45 kg.

Allgemeine Hinweise

- Es darf immer nur ein Kind gleichzeitig auf der Schaukel sitzen.
- Die Schaukel ist für den Außenbereich konzipiert.
- Überprüfen Sie vor jeder Benutzung alle Muttern, Schrauben und Anschlusssteile auf festen Sitz und ziehen Sie sie nach, wenn nötig.
- Überprüfen Sie vor jeder Benutzung alle Abdeckungen für Schrauben und scharfe Kanten und ersetzen Sie sie, falls nötig.
- Ölen Sie regelmäßig alle beweglichen Metallteile.
- Überprüfen Sie regelmäßig den Schaukelsitz, die Seile und alle anderen Teile auf Verschleiß. Falls nötig, ersetzen Sie die Teile nach Anweisung des Herstellers.
- Überprüfen Sie die Schaukel in regelmäßigen Abständen vorsorglich auf Anzeichen für Verschleiß und Schäden.

Hinweise zu Standort

- Stellen Sie die Schaukel auf einen flachen, ebenen Untergrund und halten Sie um die Schaukel mindestens 2 Meter Abstand zu Zäunen, Garagen, Häusern, Mauern, herunterhängenden Ästen oder elektrischen Kabeln.
- Aus Sicherheitsgründen muss die Schaukel im Boden verankert werden. Verankern Sie die Schaukel bündig am oder im Boden, damit Keiner über die Verankerung stolpert.
- Achten Sie darauf, dass ihr Kind nicht der Sonne zugewandt schaukelt, um Augenschäden durch direktes Sonnenlicht zu vermeiden.
- Um sich den Aufbau zu erleichtern, ziehen Sie alle Zubehörteile zunächst nur handfest an. Ziehen Sie die Teile erst fest, wenn Sie den Aufbau beendet haben.
- Stellen Sie die Schaukel nicht auf einen betonierten, asphaltierten oder harten Untergrund.





Hinweise zur Benutzung

- Achten Sie darauf, dass Kinder nicht im Stehen schaukeln.
- Achten Sie darauf, dass Kinder nicht von der Schaukel steigen, solange sie sich noch bewegt.
- Verdrehen Sie die Schwingseile nicht und wickeln Sie sie nicht um die obere Stange.
- Achten Sie darauf, dass Kinder beim Schaukeln keine weite, offene Kleidung oder Kapuzenshirts anhaben, damit sie sich mit der Kleidung nicht in der Schaukel verfangen.
- Achten Sie darauf, dass Kinder nicht auf der Schaukel herumklettern.
- Achten Sie darauf, dass andere Kinder nicht in der Nähe der Schaukel spielen, solange sie benutzt wird.

Hinweise zu Aufbau und Wartung



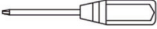

- Um Verletzungen zu vermeiden, halten Sie sich genau an die hier beschriebenen Hinweise zum Aufbau und zur Wartung.
- Verpackungsmaterialien sind kein Spielzeug. Entsorgen Sie alle Verpackungsmaterialien umgehend und achten Sie darauf, dass Sie nicht in die Hände von Kindern gelangen.
- Die Schaukel darf nur von Erwachsenen zusammengebaut werden.
- Unter Aufsicht eines Erwachsenen darf die Wartung auch von Kindern durchgeführt werden.
- Das Gerät ist nur für private Haushalte ausgelegt.
- Sobald die Schaukel komplett zusammengebaut ist überprüfen Sie sie vor der Benutzung noch einmal sorgfältig. Falls Sie problematische Stellen oder Schäden entdecken, achten Sie darauf, dass niemand die Schaukel benutzt, bis sie wieder einsatzfähig ist.

BENÖTIGTE WERKZEUGE







			
Hammer	Messband	Inbusschlüssel (enthalten)	Schlüssel (enthalten)
			
Schraubenzieher			

LIEFERUMFANG







Diese Teile benötigen Sie für den Rahmen (PCS = Stück):

A1		Oberrohr links	1 PCS
A2		Langes Oberrohr	1 PCS
A3		Beinoberteil	4 PCS
A5		Beinunterteil	4 PCS
A6		Querstrebe	2 PCS







Diese Zubehörteile benötigen zum Zusammenbau des Rahmens (PCS = Stück):

B1		Schraube 5/16" * 63 mm	14 PCS
B2		Schraube 5/16" * 63 mm	4 PCS
B3		Mutter 5/16"	18 PCS
B4		Plastikkappe	18 PCS
B5		Unterlegscheibe	32 PCS
B6		Unterlegscheibe	4 PCS









Diese Teile benötigen Sie für die Wippe (PCS = Stück):

L1		Bügel	2PCS
L2		Sitzaufhängung	2 PCS
M1		Kappe (montiert)	2 PCS
M2		Kleines Lager (montiert)	2 PCS
M3		Großes Lager (montiert)	4 PCS
M4		Sitz	2 PCS
M5		Fußstütze	2 PCS





Diese Klammern benötigen Sie zum Zusammenbau der Wippe (PCS = Stück):

L4		Klemme	1 PCS
L5		Bügelschelle	1 PCS
L6		Unterlegscheibe	4 PCS
N3		Schraube 5/16" * 25 mm	2 PCS
N8		Mutter 5/16"	2 PCS
N14		Plastikkappe	2 PCS



**Diese Zubehörteile benötigen Sie zum Zusammenbau der Wippe
(PCS = Stück):**

N1		Bolzen 1/4" * 35 mm	4 PCS
N2		Bolzen 1/4" * 45 mm	2 PCS
N5		Schraube V6 Ø 5*15	4 PCS
N6		Hakenschraube	2 PCS
N7		Federscheibe	4 PCS
N9		Unterlegscheibe	12 PCS
N11		Mutter 1/4"	4 PCS
N12		Mutter	4 PCS

Diese Teile benötigen Sie für den Schaukelsitz (PCS = Stück):

J1		Ummantelte Kette	4 PCS
J3		Augenschraube & Zubehör	4 PCS
J4		Augenschraube (montiert)	4 PCS
K1		Schaukelsitz	2 PCS

**Diese Zubehörteile benötigen Sie zum Zusammenbau des Schaukelsitzes
(PCS = Stück):**

J6		Mutter 5/16"	8 PCS
J8		Unterlegscheibe	8 PCS
J9		Plastikkappe	8 PCS

MONTAGE

Wichtige Hinweise zur Montage

- Bauen Sie die Schaukel auf einem geraden, ebenen Untergrund auf und halten Sie um die Schaukel herum einen Abstand von 2 Metern zu Zäunen, herunterhängenden Ästen, Stromkabeln, Häusern oder anderen Objekten.
- Stellen Sie die Schaukel nicht auf Beton, Asphalt oder anderen harten Untergründen auf, damit sich die Kinder beim Herunterfallen nicht verletzen.
- Ziehen Sie die Muttern und Schrauben während der Montage nicht zu fest an. So vereinfachen Sie sich den Aufbau und können Anpassungen schneller vornehmen.
- Sobald Sie mit der Montage fertig sind, ziehen Sie erst alle Schrauben und Muttern fest, bevor Sie das Gerät zum ersten Mal benutzen.

So bauen Sie die Schaukel zusammen

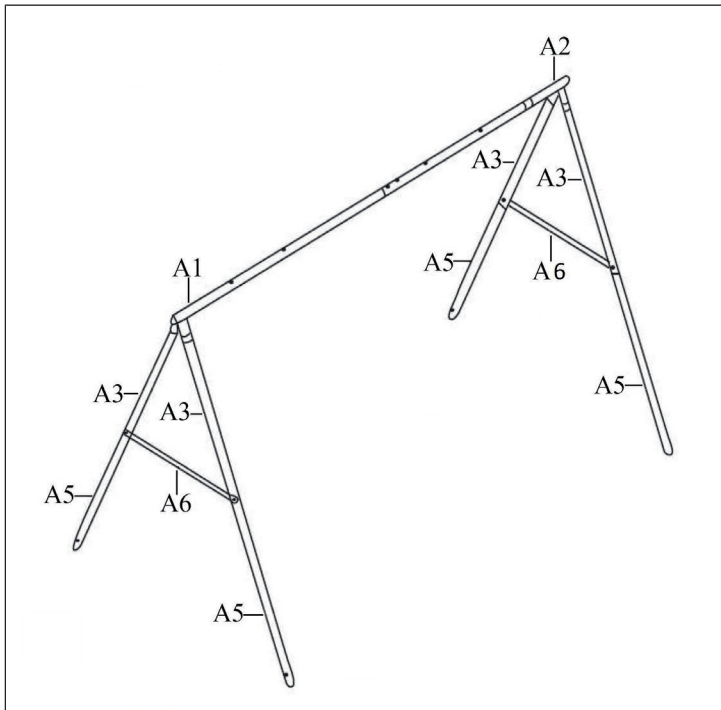

- A1: Oberrohr links
 A2: Langes Oberrohr
 A3: Beinoberteil
 A5: Beinunterteil
 A6: Querstrebe

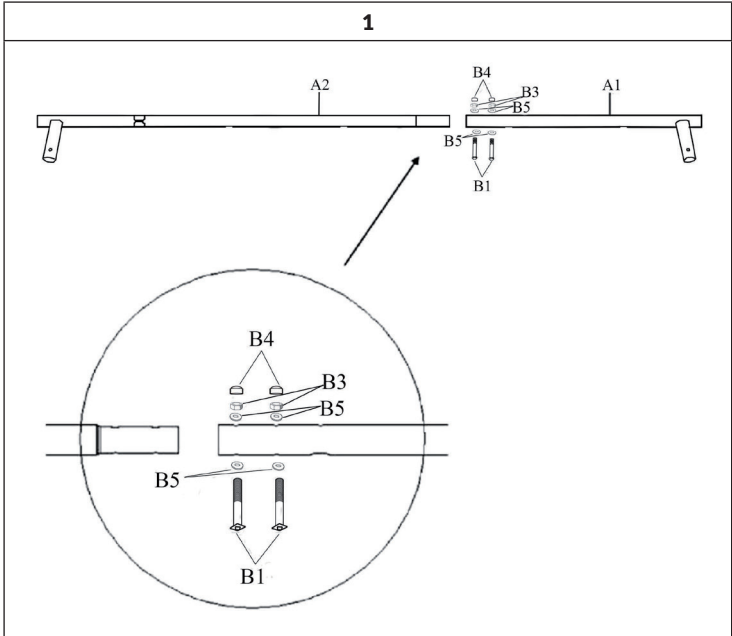

Schieben Sie A1 (Oberrohr links) auf A2 (Langes Oberrohr) und befestigen Sie die Rohre mit den Teilen B1 (Bolzen), B5 (Unterlegscheiben), B3 (Muttern) und B4 (Plastikkappen)

Hinweis: Versichern Sie sich, dass das konkave Loch nach unten zeigt.

2

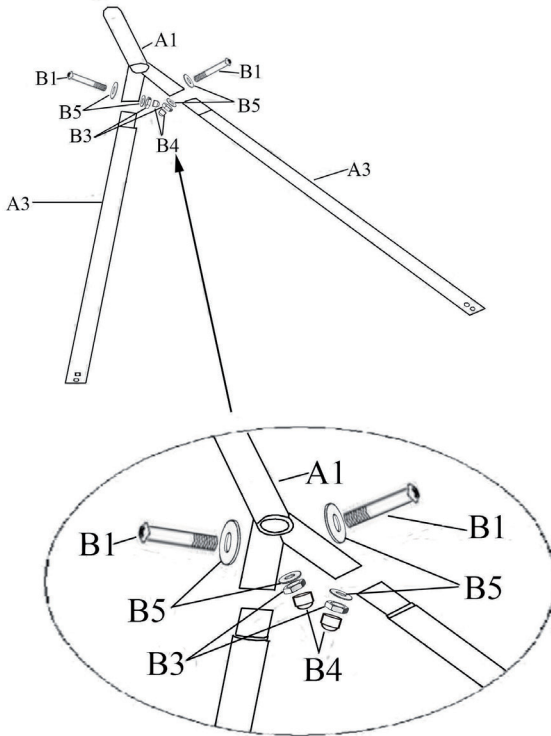

Stecken Sie das kurze Ende von A3 (Beinoberteil) in den Sockel am Ende von A1 (Oberrohr links) und richten Sie die Löcher aneinander aus.

Benutzen Sie zur Befestigung die Teile B1 (Bolzen), B5 (Unterlegscheiben), B3 (Muttern) und B4 (Plastikkappen).

Befestigen Sie die anderen zwei Beinoberteile auf die gleiche Weise am Sockel auf der anderen Seite von A2 (Langes Oberrohr).

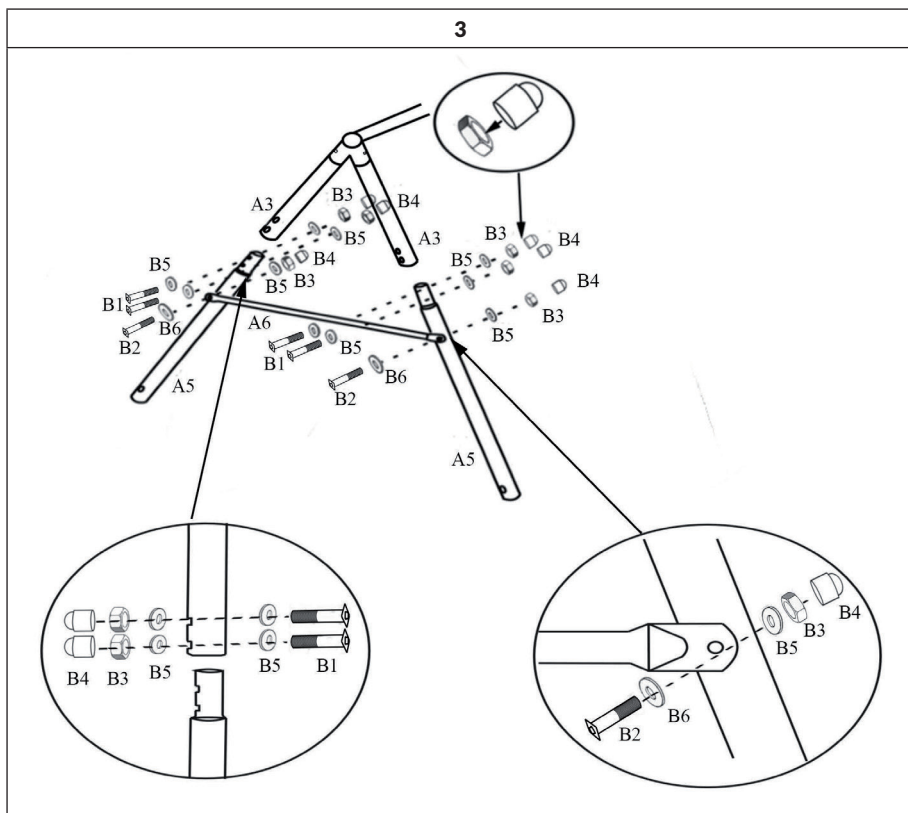

Stecken Sie das Ende von A3 (Beinoberteil) in den Sockel von A5 (Beinunterteil) und richten Sie die Löcher aneinander aus.

Benutzen Sie zur Befestigung die Teile B1 (Bolzen), B5 (Unterlegscheiben), B3 (Muttern) und B4 (Plastikkappen).

Schieben Sie A6 (Querstrebe) auf A5 (Beinunterteil) und befestigen Sie die Querstrebe mit den Teilen B2 (Bolzen), B6 (Federscheiben), B5 (Unterlegscheiben), B3 (Muttern) und B4 (Plastikkappen).

Wiederholen Sie die Schritte, um A3 (Beinoberteil), A5 (Beinunterteil) und A6 (Querstrebe) auf der anderen Seite von A2 (Langes Oberrohr) zu befestigen.

4

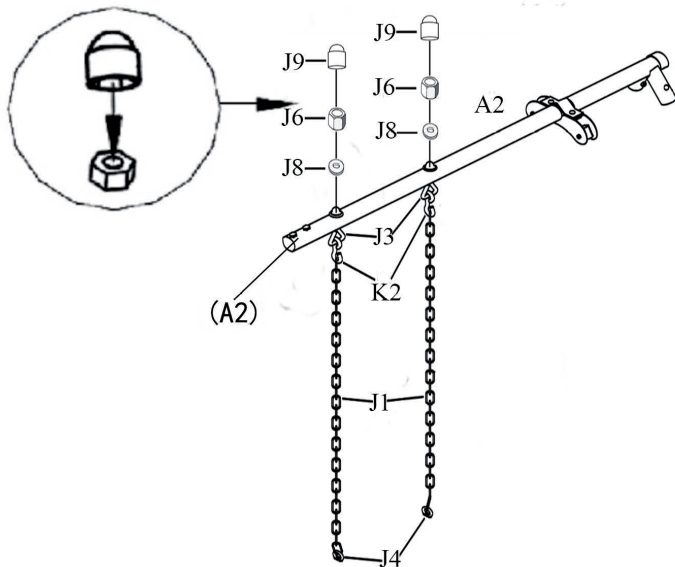

Schieben Sie J3 (Augenschraube & Zubehör) durch die Löcher von A1 (Oberrohr links) auf A2 (Langes Oberrohr).

Sichern Sie die Augenschrauben mit den Teilen J8 (Unterlegscheiben), J9 (Plastikkappen) und J6 (Muttern).

5

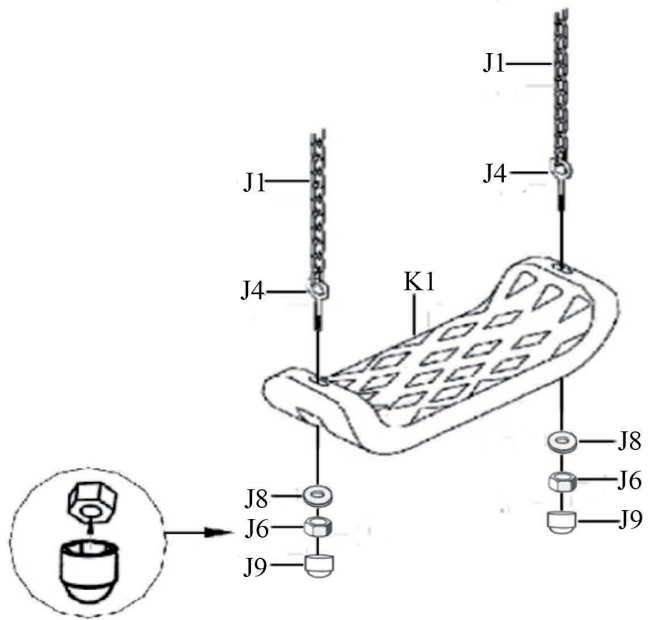

J4 (Augenschraube) und K1 (Schaukelsitz) sind bereits montiert.

Falls die beiden Teile nicht vormontiert wurden, befestigen Sie J4 und K1, wie auf der Abbildung dargestellt. Benutzen Sie zur Befestigung die Teile J8 (Unterlegscheiben), J9 (Plastikkappen) und J6 (Muttern).

6

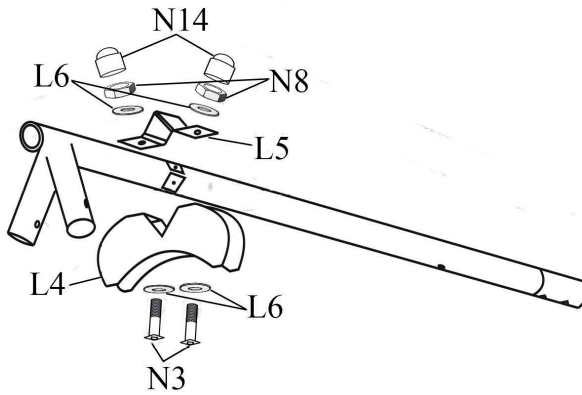

Befestigen Sie L5 (Bügelschelle), L4 (Klemme) und L6 (Unterlegscheiben) an A2 (Langes Oberrohr), wie auf der Abbildung dargestellt.

Ziehen Sie dann N3 (Schrauben) und N8 (Muttern) mit einem Schlüssel und Schraubenzieher fest.

7

Verbinden Sie M5 (Fußstütze) und L1 (Bügel). Benutzen Sie zur Befestigung die Teile N5 (Schrauben) und N9 (Unterlegscheiben).

M1 (Kappe), M2 (Kleines Lager) und L1 (Bügel) sind bereits montiert. Falls die Teile nicht vormontiert wurden, befestigen Sie M1 oben auf L1 und richten Sie die Löcher aneinander aus. Schieben Sie dann M2 durch die Löcher von M1 und L1.

8

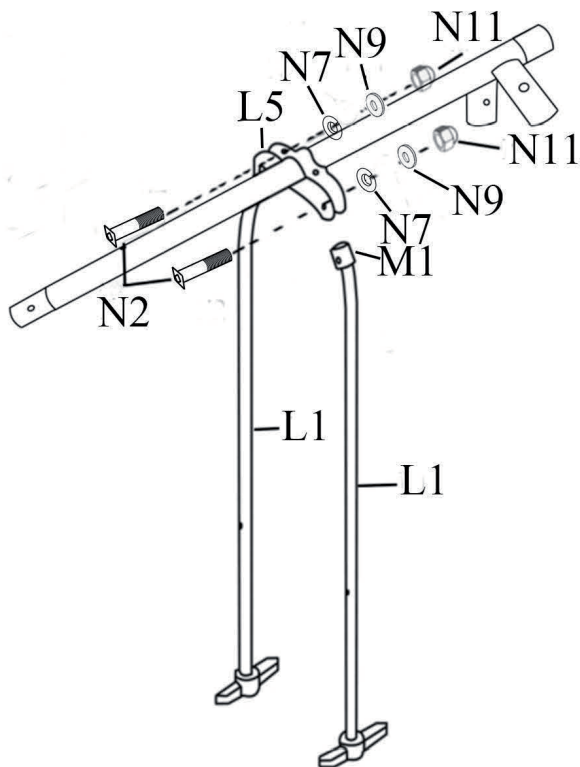

Befestigen Sie L1 (Bügel) an L5 (Bügelschelle). Benutzen Sie zur Befestigung die Teile N2 (Bolzen), N7 (Federscheibe), N9 (Unterlegscheibe) und N11 (Mutter).

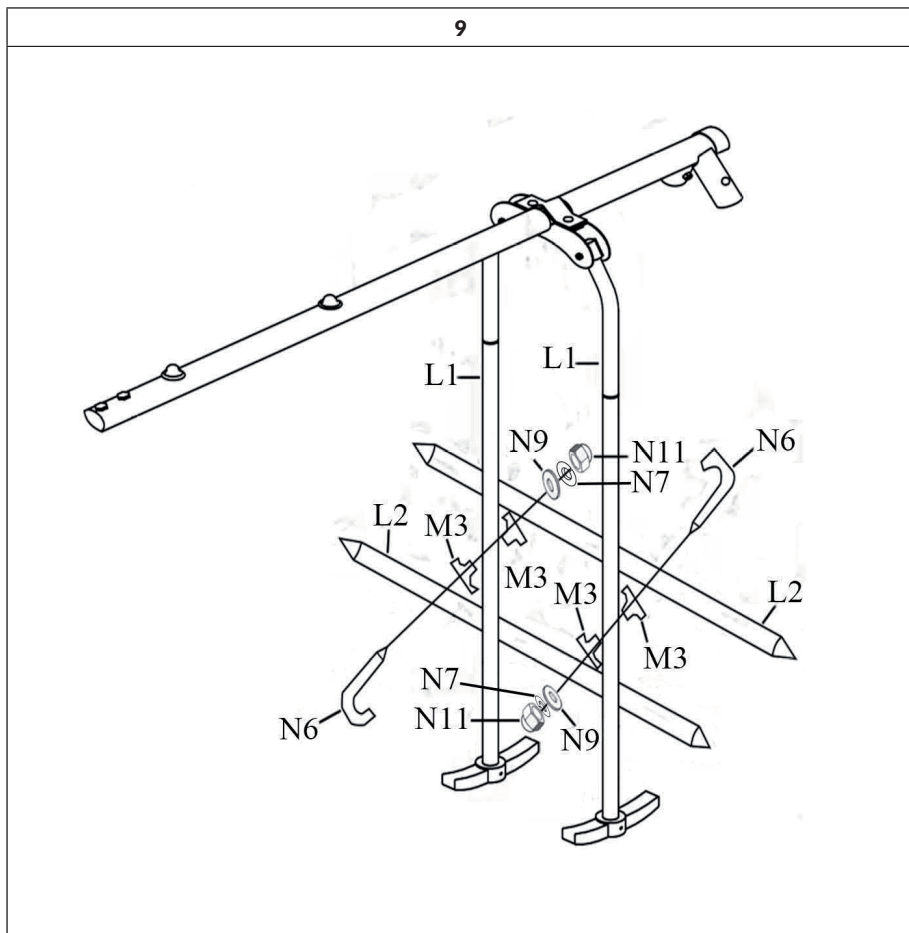

Stecken Sie 2x M3 (Großes Lager) in L1 (Bügel). Befestigen Sie dann L2 (Sitzaufhängung) an L1 (Bügel). Benutzen Sie zur Befestigung die Teile N6 (Hakenschraube), N9 (Unterlegscheiben), N7 (Federscheiben) und N11 (Muttern). Ziehen Sie die Teile aber noch nicht komplett fest!

Befestigen Sie die andere Sitzaufhängung auf gleiche Art am Bügel. Ziehen Sie erst dann alle Teile fest an.

10

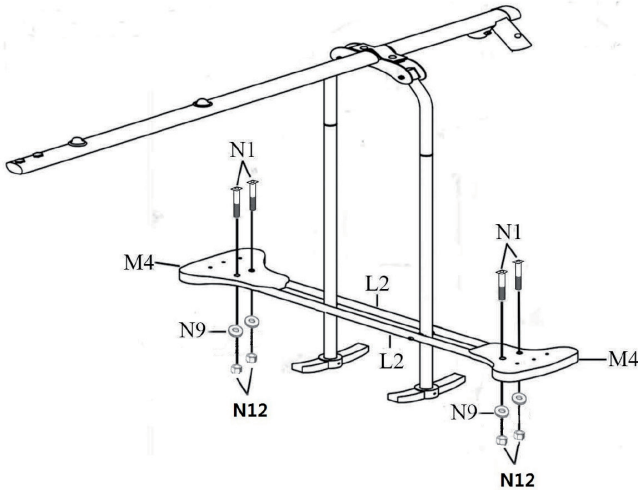

Befestigen Sie M4 (Sitz) mit N1 (Bolzen) an N2 (Sitzaufhängung).

Sichern Sie den Sitz mit den Teilen N1 (Bolzen), N9 (Unterlegscheiben) und N12 (Muttern).

VERANKERUNG

Optional können Sie die Schaukel mit Bodenankern (nicht im Lieferumfang enthalten) sichern. Der Vorteil einer Verankerung mit Bodenankern besteht darin, dass Sie das Spielgerät jederzeit verschieben oder an einem anderen Ort aufstellen können. Diese Art der Verankerung eignet sich besonders für harte Erdböden.

- Falls Sie die Schaukel in weichen Böden, z. B. Sand, verankern wollen, benutzen Sie dazu einen Spiralanker (nicht im Lieferumfang enthalten).
- Falls Sie die Schaukel dauerhaft sichern wollen, Verankern Sie sie in Beton. Stellen Sie in jeden Fall sicher, dass die Schaukel fest verankert ist, bevor Sie sie benutzen.

Hinweis: Die Beine sollten sich nach der Verankerung nicht tiefer als 76 mm unter der Erde befinden, damit noch genug Platz zum Schwingen bleibt. Vergraben Sie die Anker und den Beton aber in jeden Fall, damit niemand darüber stolpert.

So verankern Sie die Schaukel mit Spirallankern

- Achten Sie darauf, dass die Schaukel auf einem ebenen Untergrund steht.
- Drehen Sie den Spirallanker in den Untergrund, bis sich das gebogene Ende dicht über der Öffnung unten am Bein befindet.
- Führen Sie das gebogene Ende in die Öffnung ein und sichern Sie das Bein, indem Sie den Anker mit einem Hammer fest in den Boden schlagen.



So verankern Sie die Schaukel in Beton

Um die Sicherheit zu erhöhen empfehlen wir Ihnen die Schaukel, wenn möglich, in Beton zu verankern. Falls Sie die Schaukel auf losem Untergrund aufstellen, verankern Sie den Rahmen in jedem Fall in Beton (nicht im Lieferumfang enthalten). Befolgen Sie dazu die folgenden Schritte:

- Achten Sie darauf, dass Sie die Schaukel auf einem ebenen Untergrund aufstellen.
- Graben Sie an den Stellen, an denen Sie die Beine verankern wollen zylinderförmige Löcher in den Boden. Die Löcher sollten etwa 60 mm tief und 32 mm breit sein. Benutzen Sie eine Schaufel, um den unteren Teil des Loches zu erweitern, so dass der Bodendurchmesser des Lochs größer ist, als die obere Öffnung (siehe Abbildung). Bereiten Sie in der Mitte des Lochs ein 51 mm hohes Kies- oder Steinbett für die Beine der Schaukel (siehe Abbildung).
- Setzen Sie nun die Schaukelbeine in die Löcher und füllen Sie die Löcher mit etwa 20,5 kg Beton.

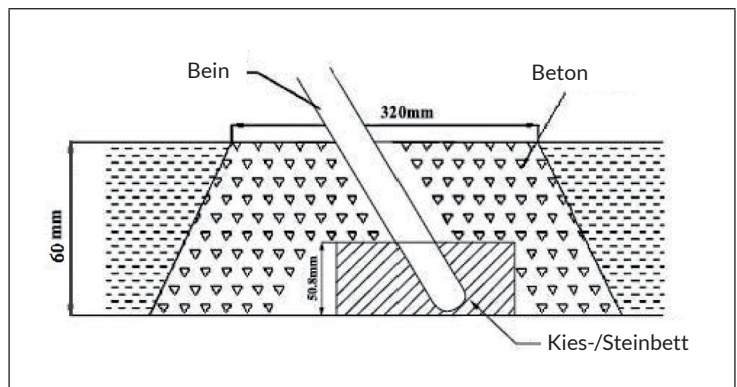

- Bedecken Sie den Beton mit Erde, damit sich später niemand daran verletzt.
- Lassen Sie den Beton 6-7 Tage lang gut durchtrocknen, bevor Sie die Schaukel benutzen.
- Der Abstand vom Schaukelsitz zum Boden sollte mindestens 350 mm betragen.

HERSTELLER & IMPORTEUR (UK)

Hersteller:

Chal-Tec GmbH, Wallstraße 16, 10179 Berlin, Deutschland.

Importeur für Großbritannien:

Berlin Brands Group UK Limited

PO Box 42

272 Kensington High Street

London, W8 6ND

United Kingdom

Dear Customer,

Congratulations on purchasing this device. Please read the following instructions carefully and follow them to prevent possible damages. We assume no liability for damage caused by disregard of the instructions and improper use. Scan the QR code to get access to the latest user manual and more product information.



CONTENTS

Safety Instructions	24
Required Tools	26
Scope of Delivery	26
Mounting	29
Anchoring	39
Manufacturer & Importer (UK)	41

TECHNICAL DATA

Item number	10026906, 10026907
Maximum permissible body weight	Up to 45 kg

SAFETY INSTRUCTIONS

Hints on age and weight



The swing is suitable for children aged 3-8 years. The swing is not suitable for children under 3 years of age, as they could be injured by small parts or the long ropes. The swing is not suitable for adults or children weighing more than 45 kg.

General Hints

- Only one child per seat at any one time.
- For outdoor use.
- Check all nuts, bolts and fittings for tightness and tighten if required.
- Check all coverings for bolts and sharp edges and replace when required
- Oil all metallic moving parts.
- Check swing seats, ropes and other means of attachments for evidence of deterioration. Replace when required in accordance with the manufacturer's instructions.
- Please take note: As an extra precaution, check this toy regularly for signs of wear and damage.

Hints on Placement

- Place the product on a level surface at least 2 metres from any obstructions such as a fence, garage, house, wall, overhanging branches, laundry line or electrical wires.
- For safety reasons, this swing must be anchored into the ground.
- Anchors shall be placed level with or under the ground in order to reduce tripping hazards.
- Ensure the child is not facing the sun when on the swing.
- Leave all fittings finger tight until assembly is complete, for ease of construction. Then tighten firmly.
- Do not install the product on concrete, asphalt or hard surfaces.





Hints on Use

- Do not allow children to stand on the swing or glider seats.
- Do not allow children to get off the swings or glider while they are still moving.
- Do not twist swing ropes or wrap them over the top bar.
- Do not allow loose, hooded or baggy clothes to be worn since children can get trapped and may be unable to free themselves.
- Do not allow children to climb on this equipment.
- Do not allow children to wander into the play area when the equipment is in use.
- Gliders and swings must not exceed an angle of 60 degrees from the ground.

Hints on mounting and maintenance





- Failure to assemble and maintain this item as per these instructions may cause injury to the user.
- Packaging materials are not toys. Please remove all packaging and packing tags / wires before giving this toy to your child.
- Adult assembly required.
- For use under adult supervision.
- Maintenance to be carried out under the direct supervision of a responsible adult.
- For family domestic use only.
- Once assembly is complete, carefully check the equipment before use. If you find any problems, do not allow children to use the equipment until it is fit for use.

REQUIRED TOOLS







			
Hammer	Measuring tape	Allen wrench (included)	Wrench (included)
			
Screwdriver			

SCOPE OF DELIVERY







The parts displayed below are for the main frame assembly:

A1		Top tube left	1 PCS
A2		Long top tube	1 PCS
A3		Upper leg section	4 PCS
A5		Lower leg section	4 PCS
A6		Cross brace	2 PCS







The hardware displayed below is for the main frame assembly:

B1		Screw 5/16" * 63 mm	14 PCS
B2		Screw 5/16" * 63 mm	4 PCS
B3		Nut 5/16"	18 PCS
B4		Plastic cap	18 PCS
B5		Washer	32 PCS
B6		Washer	4 PCS









The parts displayed below are for the glide ride assembly:

L1		Bracket	2PCS
L2		Seat suspension	2 PCS
M1		Cap (mounted)	2 PCS
M2		Small bearing (mounted)	2 PCS
M3		Large bearing (mounted)	4 PCS
M4		Seat	2 PCS
M5		Footrest	2 PCS





The brackets displayed below are used for the glide ride assembly:

L4		Terminal	1 PCS
L5		U-bolt clamp	1 PCS
L6		Washer	4 PCS
N3		Screw 5/16" * 25 mm	2 PCS
N8		Nut 5/16"	2 PCS
N14		Plastic cap	2 PCS



The hardware displayed below is used for the glide ride assembly:

N1		Bolt 1/4" * 35 mm	4 PCS
N2		Bolt 1/4" * 45 mm	2 PCS
N5		Screw V6 Ø 5*15	4 PCS
N6		Hook bolt	2 PCS
N7		Spring washer	4 PCS
N9		Washer	12 PCS
N11		Nut 1/4"	4 PCS
N12		Mother	4 PCS

The parts displayed below are used for the swing seat assembly:

J1		Sheathed chain	4 PCS
J3		Eyebolt & Accessories	4 PCS
J4		Eye bolt (mounted)	4 PCS
K1		Swing seat	2 PCS

The hardware displayed below is used for the swing seats:

J6		Nut 5/16"	8 PCS
J8		Washer	8 PCS
J9		Plastic cap	8 PCS

MOUNTING

Assembly Instructions

- Please the playground equipment on level ground, not less than 6ft (1.8m) from any structure or obstruction such as a fence, garage, house, overhanging branches, laundry lines or electrical wires.
- Do not install the playground equipment over concrete, asphalt, packed earth or any other hard surface. A fall onto a hard surface can result in serious injury to the user.
- Do not over-tighten the nuts and bolts when you are assembling your playground equipment. This will allow for some possible adjustments and ease of installation.
- Once you have finished the assembly of the playground equipment go back over all of the nuts and bolts and properly tighten all of them before using the playground equipment

Mounting Instructions

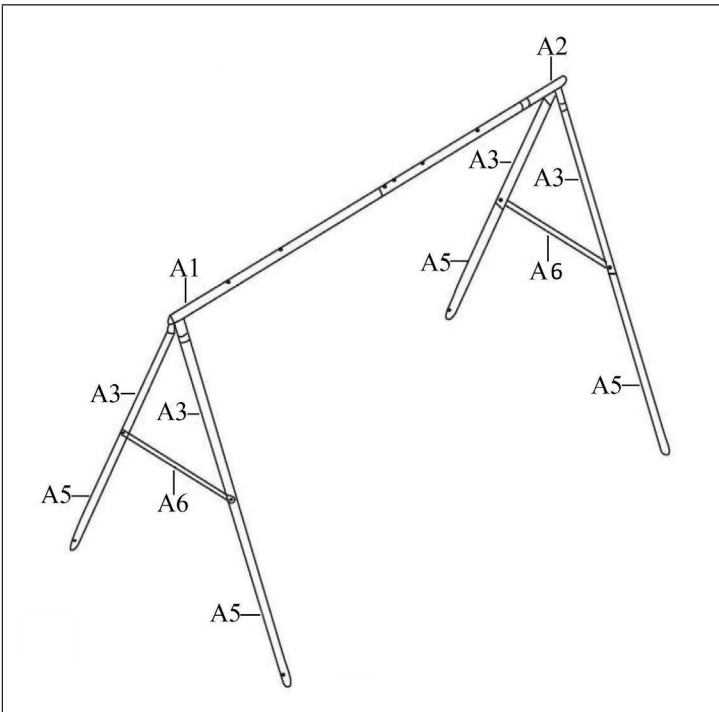

- A1: Top tube left
- A2: Long top tube
- A3: Upper leg section
- A5: Lower leg section
- A6: Cross brace

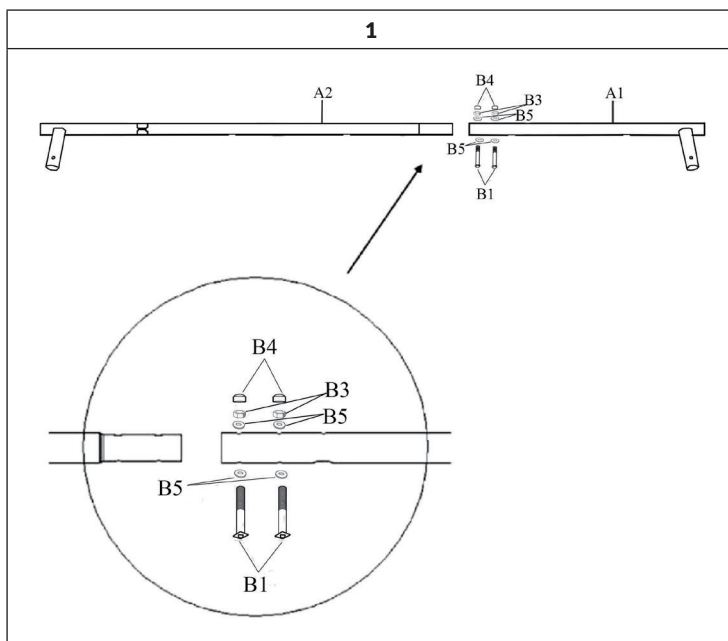

Slide A1 (left top tube) onto A2 (long top tube) and secure the tubes with parts B1 (bolts), B5 (washers), B3 (nuts) and B4 (plastic caps)

Note: Ensure that the concave hole is facing down.

2

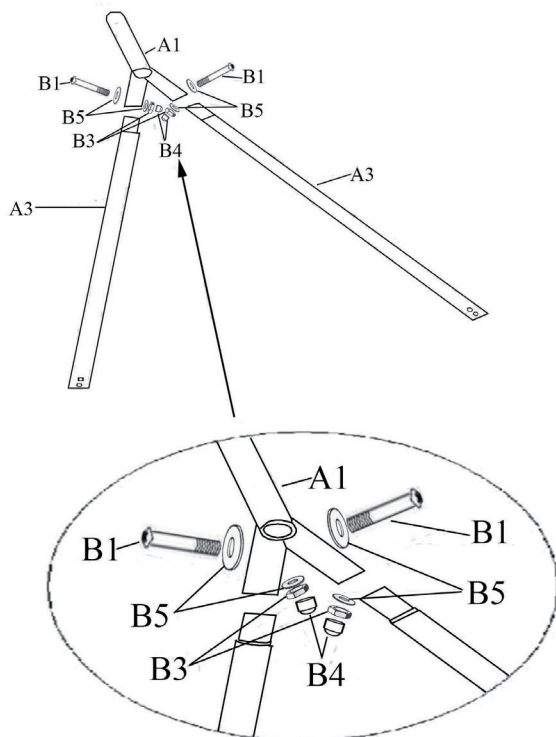

Insert the short end of A3 (leg top) into the socket at the end of A1 (top tube left) and align the holes.

Use parts B1 (bolts), B5 (washers), B3 (nuts) and B4 (plastic caps) to secure.

Attach the other two leg tops in the same way to the base on the other side of A2 (long top tube).

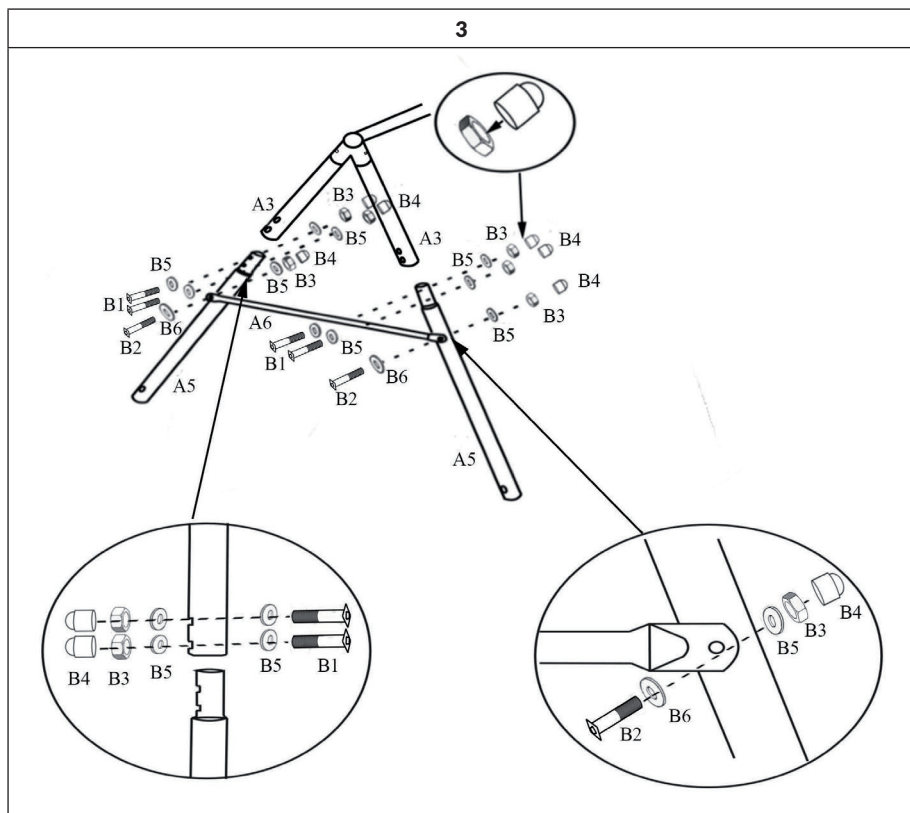

Insert the end of A3 (leg top) into the socket of A5 (lower leg section) and align the holes with each other.

Use parts B1 (bolts) for fastening, B5 (washers), B3 (nuts) and B4 (plastic caps).

Slide A6 (cross brace) onto A5 (lower leg section) and secure the cross brace with parts B2 (bolts), B6 (spring washers),

B5 (washers), B3 (nuts) and B4 (plastic caps).

Repeat the steps to attach A3 (leg top), A5 (leg bottom) and A6 (cross brace) on the other side of A2 (long top tube).

4

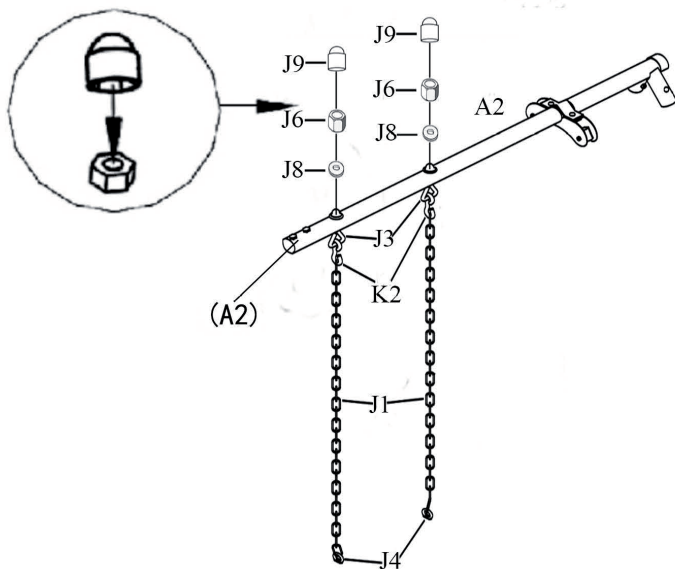

Slide J3 (eye bolt & accessories) through the holes from A1 (top tube left) to A2 (long top tube).

Secure the eye bolts with parts J8 (washers), J9 (plastic caps) and J6 (nuts).

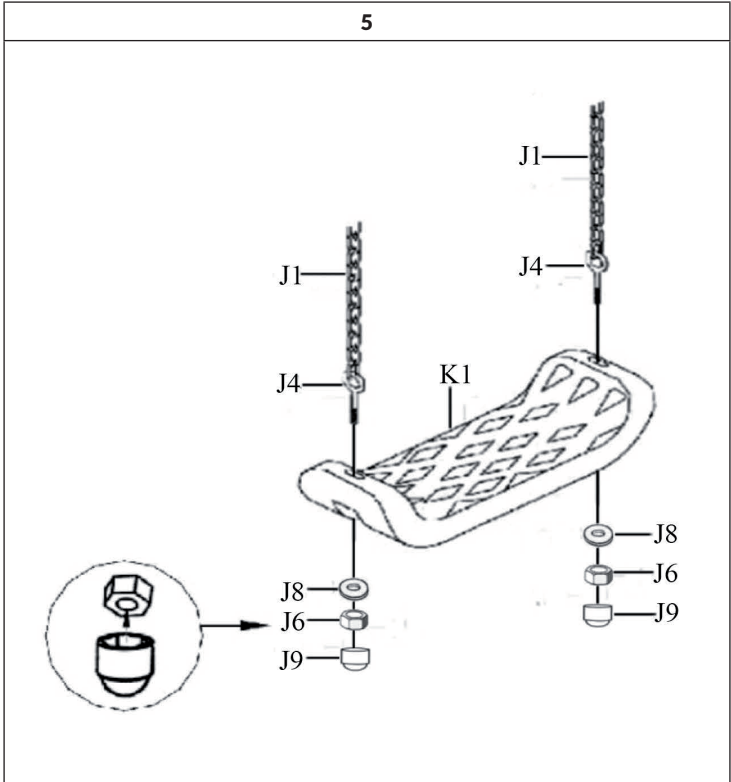

J4 (eye bolt) and K1 (swing seat) are already mounted.

If the two parts are not pre-assembled, fasten J4 and K1 as shown in the figure. Use parts J8 (washers), J9 (plastic caps) and J6 (nuts) for fastening.

6

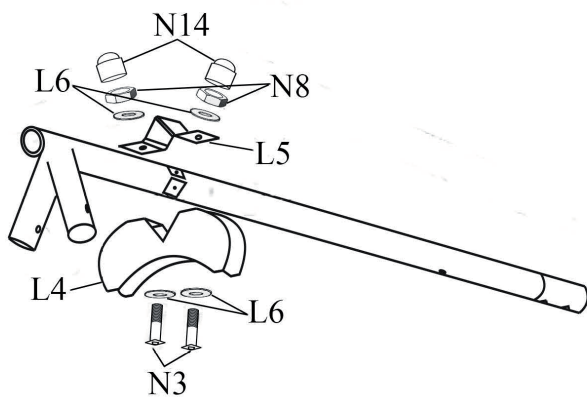

Attach L5 (bracket clip), L4 (clamp) and L6 (washers) to A2 (long top tube) as shown in the illustration.

Then tighten N3 (bolts) and N8 (nuts) with a spanner and screwdriver.

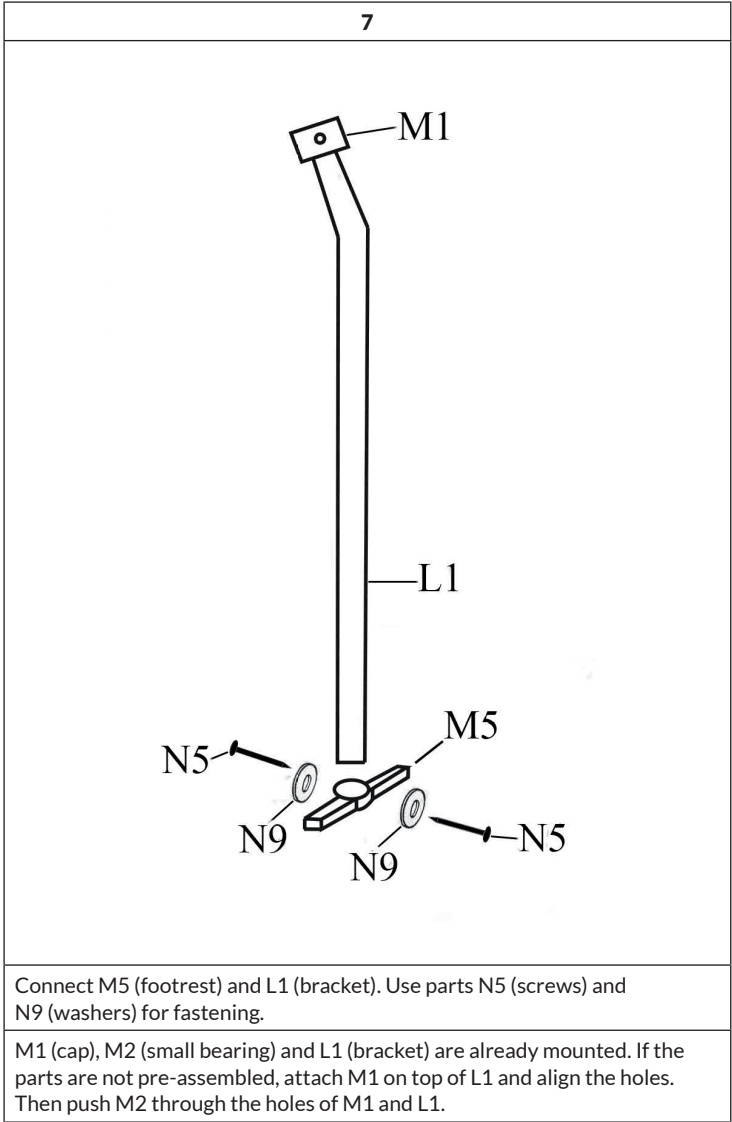

8

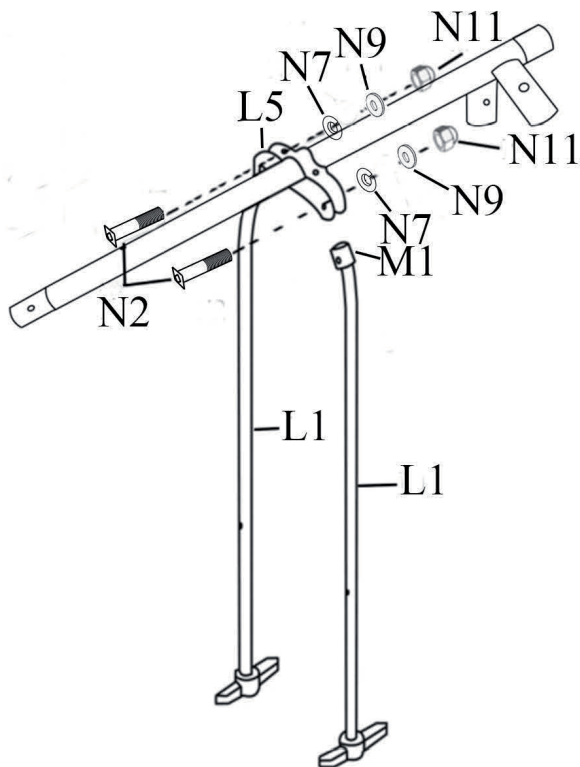

Attach L1 (bracket) to L5 (bracket clip). Use parts N2 (bolt), N7 (spring washer), N9 (washer) and N11 (nuts) for fastening.

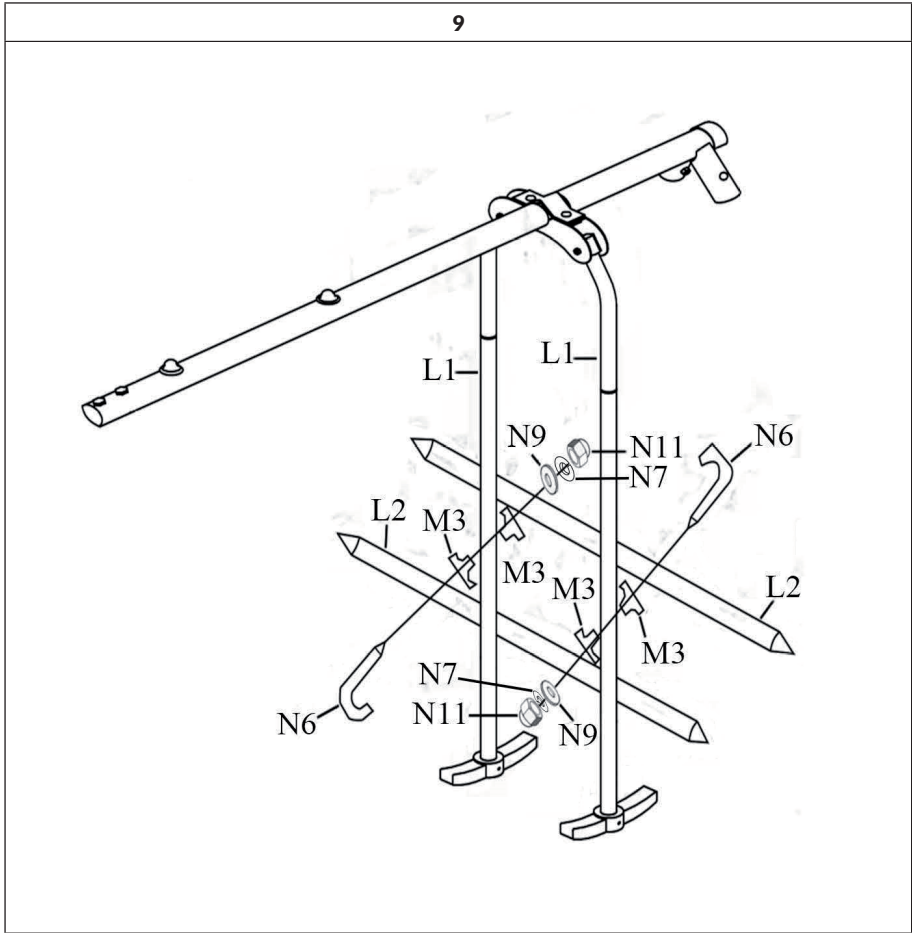

Insert 2x M3 (large bearing) into L1 (bracket). Then attach L2 (seat suspension) to L1 (bracket). Use parts N6 (hook bolt), N9 (washers), N7 (spring washers) and N11 (nuts) for fixing. But do not tighten the parts completely yet!

Fasten the other seat suspension to the bracket in the same way. Only then tighten all parts.

10

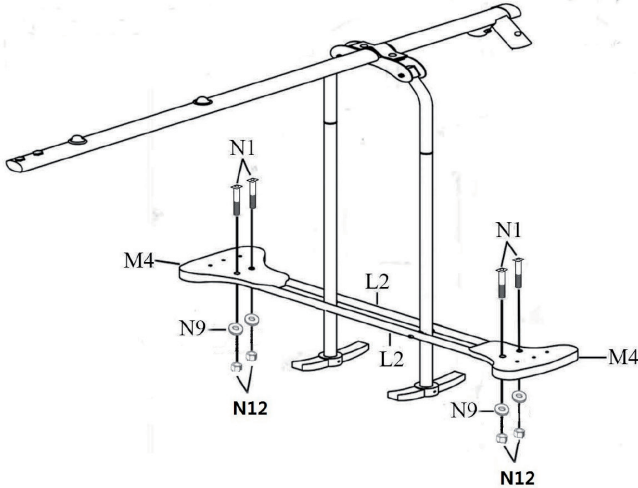

Attach M4 (seat) with N1 (bolt) to N2 (seat suspension).

Secure the seat with parts N1 (bolts), N9 (washers) and N12 (nuts).

ANCHORING

Optionally you can secure the swing with ground anchors (not included). The advantage of anchoring with ground anchors is that you can move the play equipment at any time or move it to another location. This type of anchoring is particularly suitable for hard ground.

- If your soil is soft (sand, etc.), the corkscrew method is recommended.
- If you wish to permanently secure your set, either type of anchor may set in concrete.

Note: Ensure equipment is firmly anchored (cementing is usually recommended). Before equipment is completed, do not bury the legs more than 76 mm below the ground surface. This will ensure sufficient space remains under the swinging plays. Be certain that all anchoring devices (including concrete) are placed below the level of the playing surface or below ground level to prevent tripping.

Corkscrew Anchors

- Be sure the swing set, is located on level ground.
- Turn the corkscrew anchor into the ground until only the hooked end is above the ground next to the leg.
- Insert the hooked end into the bottom opening of the leg. Ensure that the hooked end is secure in the let opening.



Anchoring in Concrete

To increase safety, we recommend that you anchor the swing in concrete if possible. If you place the swing on a loose surface, always anchor the frame in concrete (not included). Follow the steps below to do this:

- Make sure that you place the swing on a level surface.
- Dig cylindrical holes in the ground where you want to anchor the legs. The holes should be about 60 mm deep and 32 mm wide. Use a shovel to widen the lower part of the hole so that the bottom diameter of the hole is larger than the top opening (see illustration). In the middle of the hole, prepare a 51 mm high gravel or stone bed for the legs of the swing (see illustration).
- Now place the rocking legs in the holes and fill the holes with about 20.5 kg of concrete.

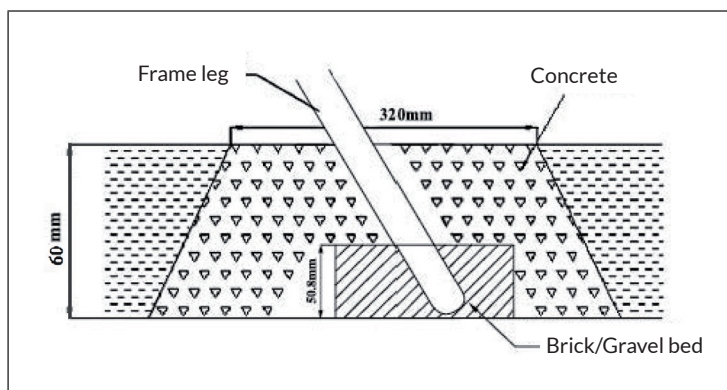

- Cover concrete with dirt and protective surface material.
- Allow about 6-7 days for concrete to dry properly.
- You must maintain a minimum of 350 mm ground clearance.

MANUFACTURER & IMPORTER (UK)

Manufacturer:

Chal-Tec GmbH, Wallstrasse 16, 10179 Berlin, Germany.

Importer for Great Britain:

Berlin Brands Group UK Limited

PO Box 42

272 Kensington High Street

London, W8 6ND

United Kingdom

Gentile cliente,

La ringraziamo per aver acquistato il dispositivo. La preghiamo di leggere attentamente le seguenti istruzioni per l'uso e di seguirle per evitare possibili danni. Non ci assumiamo alcuna responsabilità per danni scaturiti da una mancata osservazione delle avvertenze di sicurezza e da un uso improprio del dispositivo. Scansionare il codice QR seguente, per accedere al manuale d'uso più attuale e per ricevere informazioni sul prodotto.



INDICE

Avvertenze di sicurezza	44
Utensili da utilizzare	46
Volume della consegna	46
Montaggio	49
Anclaje	59
Produttore e importatore (UK)	61

DATI TECNICI

Numero articolo	10026906, 10026907
Peso corporeo massimo consentito	Fino a 45 kg

AVVERTENZE DI SICUREZZA

Avvertenze sulle limitazioni relative a età e peso

	<p>L'altalena è adatta a bambini da 3 a 8 anni. L'altalena non è adatta a bambini sotto i 3 anni, dato che potrebbero subire lesioni a causa di piccoli componenti o delle lunghe funi. L'altalena non è adatta a persone adulte e bambini che superano i 45 kg di peso.</p>
---	--

Avvertenze generiche

- Sull'altalena può essere seduto solo un bambino alla volta.
- L'altalena è progettata per spazi all'aperto.
- Prima di ogni utilizzo, controllare che tutti i bulloni, le viti e i connettori siano fissati saldamente e stringerli, se necessario.
- Prima di ogni utilizzo, controllare tutte le coperture per viti sporgenti o bordi taglienti e sostituirli, se necessario.
- Oliare regolarmente tutti i componenti mobili in metallo.
- Controllare regolarmente se la seduta dell'altalena, le funi e tutti gli altri componenti presentano usura. Se necessario, sostituire i componenti in base alle indicazioni del produttore.
- Controllare l'altalena a intervalli regolari, in modo da prevenire usura e danni.

Avvertenze sul luogo di posizionamento

- Posizionare l'altalena su un fondo piano e tenerla ad almeno 2 metri di distanza da recinti, garage, case, mura, rami pendenti o cavi elettrici.
- Per motivi di sicurezza, l'altalena deve essere ancorata al suolo. Ancorarla a livello con il suolo, in modo da non inciampare nell'ancoraggio.
- Assicurarsi che i bambini non si dondolino diretti verso il sole, in modo da evitare danni agli occhi dovuti alla luce del sole diretta.
- Per facilitare il montaggio, stringere tutti i componenti solo a mano in un primo momento. Stringere saldamente solo ad assemblaggio concluso.
- Non posizionare l'altalena su un fondo in calcestruzzo, asfalto o altri materiali duri.





Avvertenze sull'utilizzo

- Assicurarsi che i bambini non si dondolino stando in piedi.
- Assicurarsi che i bambini non scendano dall'altalena mentre è ancora in movimento.
- Non arrotolare le funi dell'altalena e non avvolgerle intorno all'asta superiore.
- Assicurarsi che i bambini non indossino abiti ampi o felpe col cappuccio quando si trovano sull'altalena, in modo che non si impiglino.
- Assicurarsi che i bambini non si arrampichino sull'altalena.
- Assicurarsi che non ci siano bambini che giocano vicino all'altalena mentre viene utilizzata.

Avvertenze su montaggio e manutenzione





- Per evitare lesioni, rispettare con attenzione tutte le avvertenze su montaggio e manutenzione.
- I materiali di imballaggio non sono giocattoli. Smaltire tutti materiali di imballaggio immediatamente e assicurarsi che non finiscano nelle mani di bambini.
- L'altalena deve essere montata da persone adulte.
- La manutenzione può essere realizzata da bambini solo con l'attenta supervisione di un adulto.
- Il dispositivo è adatto solo a contesti privati.
- Non appena l'altalena è completamente montata, controllarla con cura un'altra volta prima dell'utilizzo. Se si scoprono parti problematiche o danni, assicurarsi che nessuno la utilizzi fino a quando è di nuovo pronta all'uso.

UTENSILI DA UTILIZZARE







			
Martello	Metro	Brugola (inclusa)	Chiave (inclusa)
			
Cacciavite			

VOLUME DELLA CONSEGNA







Per il telaio servono i seguenti pezzi (PCS = pezzi):

A1		Tubo superiore sinistro	1 PCS
A2		Tubo superiore lungo	1 PCS
A3		Gamba di supporto superiore	4 PCS
A5		Gamba di supporto inferiore	4 PCS
A6		Traversa	2 PCS







Per il montaggio del telaio servono i seguenti utensili (PCS = pezzi):

B1		Vite 5/16" * 63 mm	14 PCS
B2		Vite 5/16" * 63 mm	4 PCS
B3		Dado 5/16"	18 PCS
B4		Tappo di plastica	18 PCS
B5		Rondella	32 PCS
B6		Rondella	4 PCS









Per l'altalena basculante servono i seguenti pezzi (PCS = pezzi):

L1		Staffa	2PCS
L2		Sospensione del sedile	2 PCS
M1		Tappo (montato)	2 PCS
M2		Cuscinetto piccolo (montato)	2 PCS
M3		Cuscinetto grande (montato)	4 PCS
M4		Sedile	2 PCS
M5		Poggiapiedi	2 PCS





Per montare l'altalena basculante servono i seguenti morsetti (PCS = pezzi):

L4		Morsetto	1 PCS
L5		Staffa di montaggio	1 PCS
L6		Rondella	4 PCS
N3		Vite 5/16" * 25 mm	2 PCS
N8		Dado 5/16"	2 PCS
N14		Tappo di plastica	2 PCS



**Per montare l'altalena basculante seguono i seguenti utensili
(PCS = pezzi):**

N1		Bullone 1/4" * 35 mm	4 PCS
N2		Bullone 1/4" * 45 mm	2 PCS
N5		Vite V6 ø 5*15	4 PCS
N6		Gancio a vite	2 PCS
N7		Rondella elastica	4 PCS
N9		Rondella	12 PCS
N11		Dado 1/4"	4 PCS
N12		Dado	4 PCS

Per il sedile dell'altalena servono i seguenti pezzi (PCS = pezzi):

J1		Ummantelte Kette	4 PCS
J3		Augenschraube & Zubehör	4 PCS
J4		Augenschraube (montiert)	4 PCS
K1		Schaukelsitz	2 PCS

**Per montare il sedile dell'altalena servono i seguenti utensili
(PCS = pezzi):**

J6		Dado 5/16"	8 PCS
J8		Rondella	8 PCS
J9		Tappo di plastica	8 PCS

MONTAGGIO

Avvertenze importanti per il montaggio

- Montare l'altalena su un suolo piano e dritto, assicurandosi di tenere una distanza di 2 m da recinti, rami penzolanti, cavi della corrente, case o altri oggetti.
- Non collocare l'altalena sul cemento, asfalto o altri terreni duri, per evitare che i bambini si facciano male cadendo.
- Non stringere troppo i dadi e le viti per facilitare il montaggio ed eseguire più rapidamente le correzioni.
- Dopo aver terminato di montare l'altalena, stringere bene tutti i dadi e le viti prima di utilizzare il dispositivo per la prima volta.

Montare l'altalena nel modo seguente:

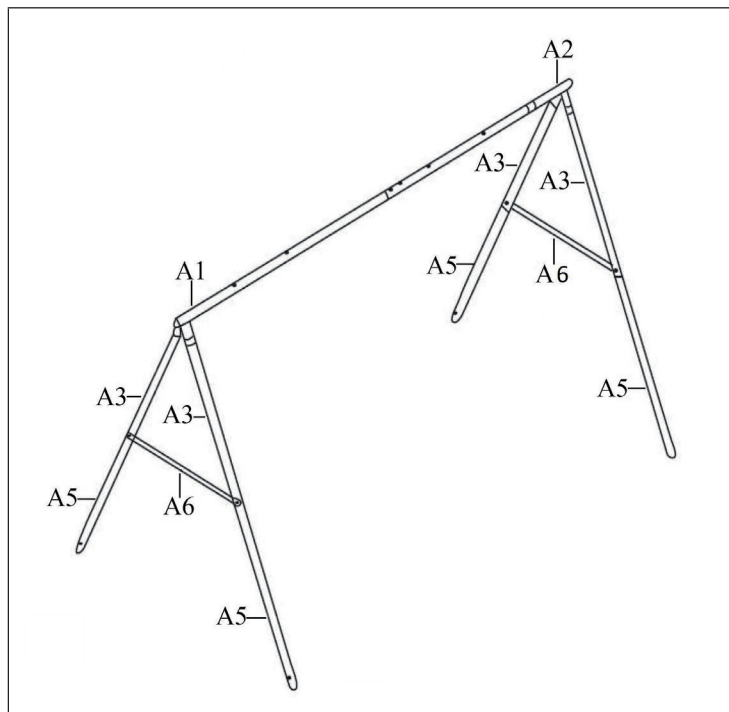

- A1: Tubo superiore sinistro
 A2: Tubo superiore lungo
 A3: Gamba di supporto superiore
 A4: Gamba di supporto inferiore
 A5: Gamba di supporto inferiore
 A6: Traversa

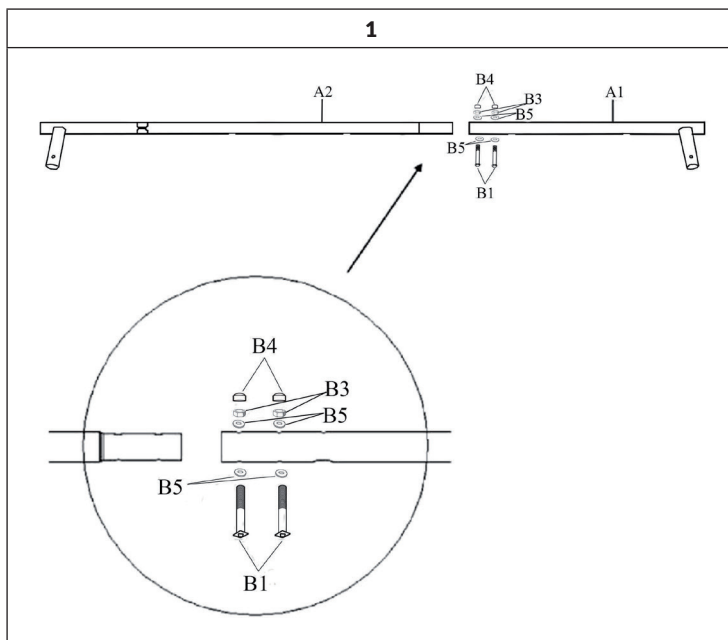

Inserire A2 (tubo superiore lungo) in A1 (tubo superiore sinistro) e stringerli con i pezzi B1 (bulloni), B5 (rondelle), B3 (dadi) e B4 (tappi di plastica).

Nota: Assicurarsi che il foro concavo sia rivolto verso il basso.

2

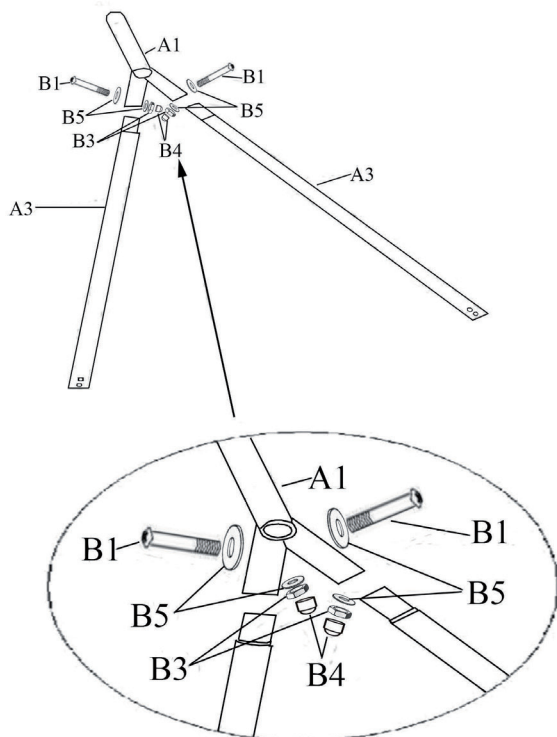

Inserire l'estremità corta di A3 (gamba di supporto superiore) nello zoccolo all'estremità di A1 (tubo superiore sinistro) e allineare i fori.

Utilizzare i pezzi B1 (bulloni), B5 (rondelle), B3 (dadi) e B4 (tappi di plastica) per fissare il tutto.

Inserire allo stesso modo le altre due gambe di supporto superiore nello zoccolo sull'altro lato di A2 (tubo superiore lungo).

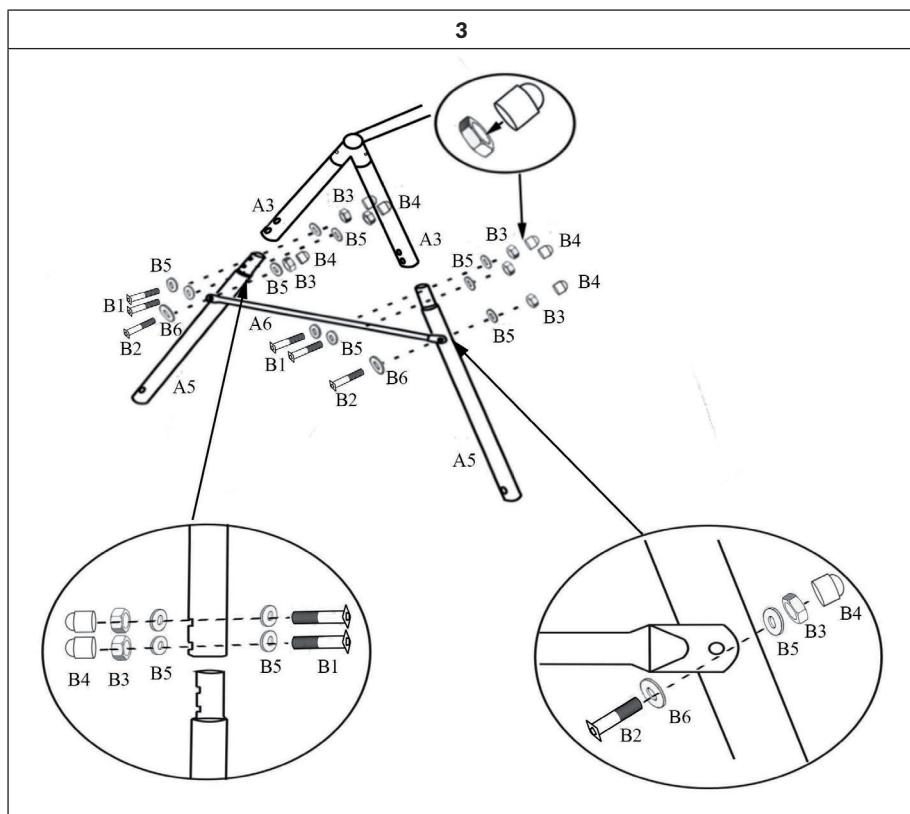

Inserire lo zoccolo di A5 (gamba di supporto inferiore) nell'estremità di A3 (gamba di supporto superiore) e allineare i fori.

Utilizzare i pezzi B1 (bulloni), B5 (rondelle), B3 (dadi) e B4 (tappi di plastica) per fissare il tutto.

Spostare A6 (traversa) su A5 (gamba di supporto inferiore) fissandola con i pezzi B2 (bulloni), B6 (rondelle elastiche), B5 (rondelle), B3 (dadi) e B4 (tappi di plastica).

Ripetere i passaggi per fissare A3 (gamba di supporto superiore), A5 (gamba di supporto inferiore) e A6 (traversa) sull'altro lato di A2 (tubo superiore lungo).

4

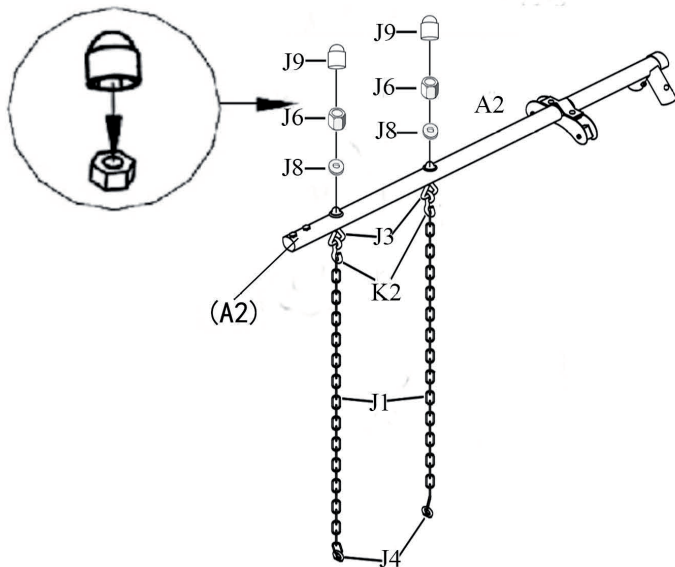

Far passare J3 (tirante a occhio & accessori) attraverso i fori da A1 (tubo superiore sinistro) ad A2 (tubo superiore lungo).

Fissare i tiranti a occhio con i pezzi J8 (rondelle), J9 (tappi di plastica) e J6 (dadi).

5

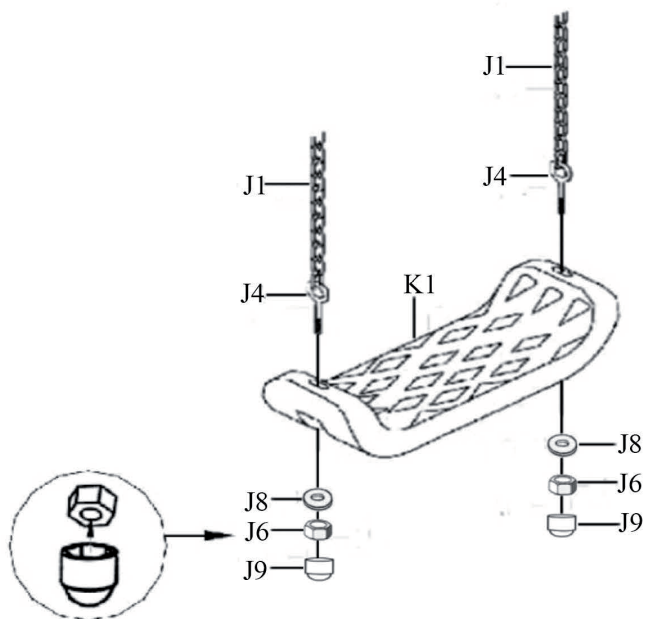

J4 (tiranti a occhio) e K1 (sedile) sono già montati.

Nel caso in cui i due pezzi non dovessero essere montati, fissare J4 e K1 come rappresentato in figura. Utilizzare i pezzi J8 (rondelle), J9 (tappi di plastica) e J6 (dadi) per fissare il tutto.

6

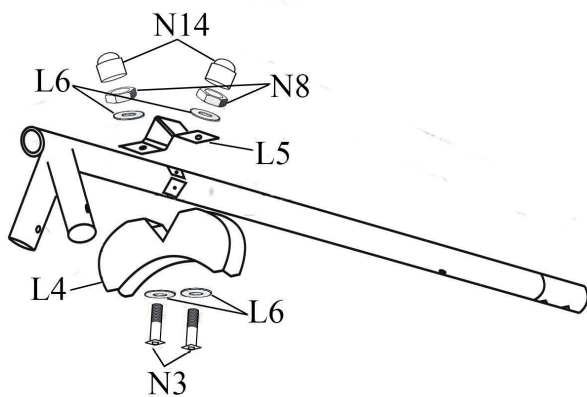

Stringere L5 (staffa di montaggio), L4 (morsetto) e L6 (rondelle) ad A2 (tubo superiore lungo) come rappresentato in figura.

Stringere poi N3 (viti) e N8 (dadi) con una chiave e il cacciavite.

7

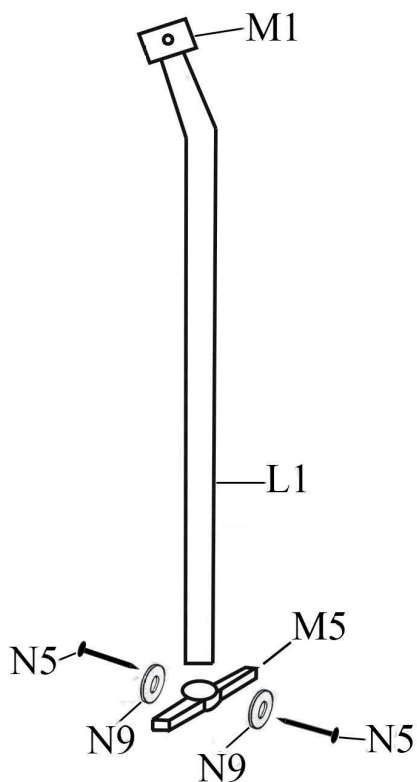

Collegare M5 (poggiapiedi) con L1 (stemma). Stringere con i pezzi N5 (viti) e N9 (rondelle).

M1 (tappo), M2 (cuscinetto piccolo) e L1 (stemma) sono già montati. In caso contrario fissare M1 su L1 e allineare i fori. Dopodiché inserire M2 nei fori di M1 e L1.

8

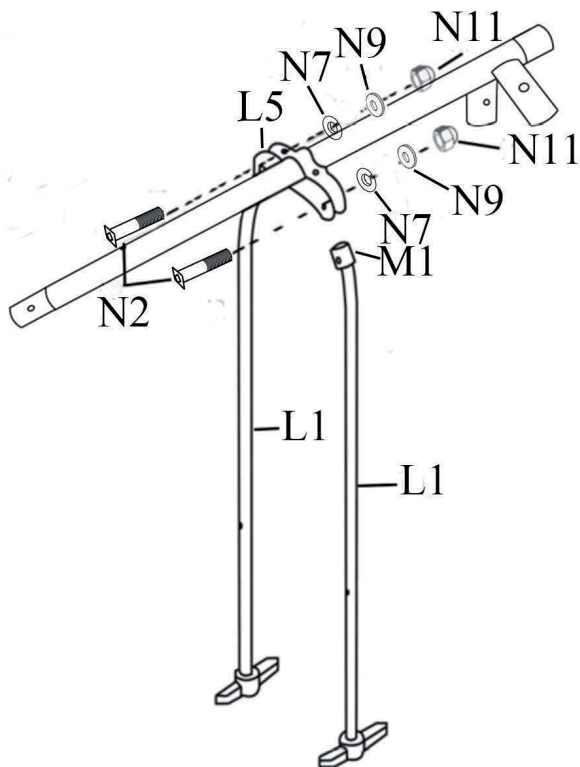

Fissare L1 (staffa) a L5 (staffa di montaggio). Stringere con i pezzi N2 (bulloni), N7 (rondelle elastiche), N9 (rondelle) N11 (dadi).

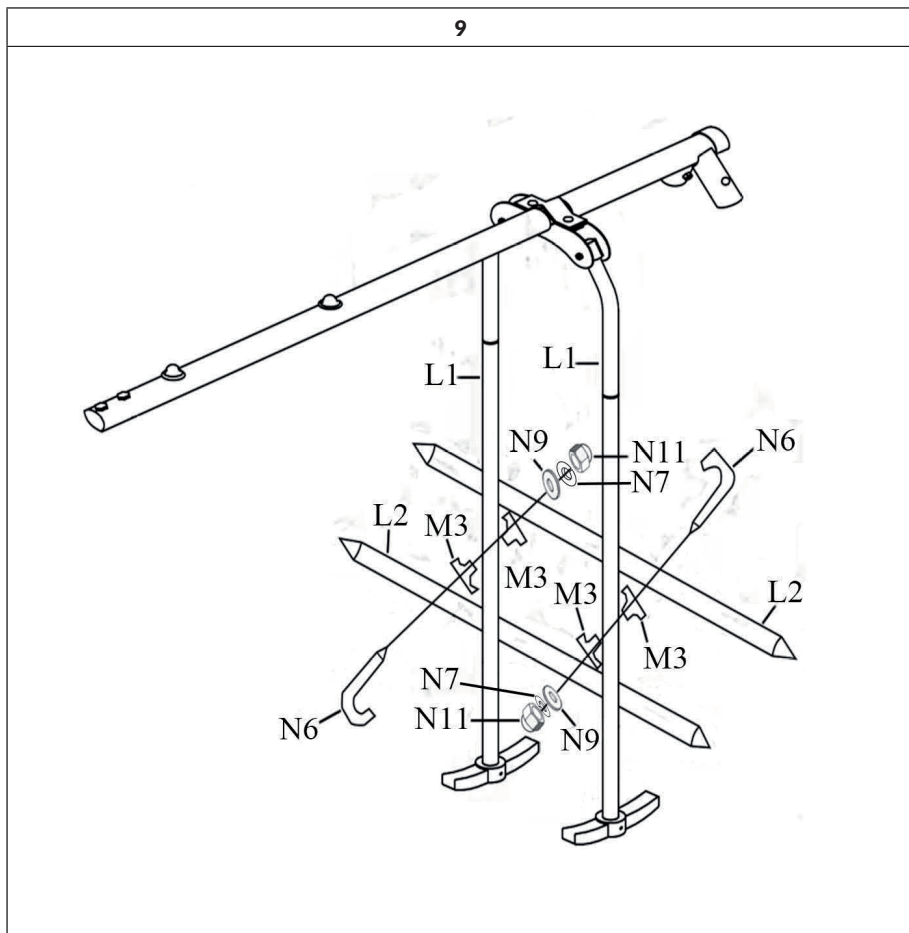

Inserire 2x M3 (cuscinetto grande) in L1 (staffa). Fissare poi L2 (sospensione del sedile) in L1 (staffa). Stringere con i pezzi N6 (ganci a vite), N9 (rondelle), N7 (rondelle elastiche) e N11 (dadi). Aspettare a stringere completamente i pezzi!

Fissare alla staffa l'altra sospensione del sedile nello stesso modo. Dopodiché stringere finalmente tutti i pezzi.

10

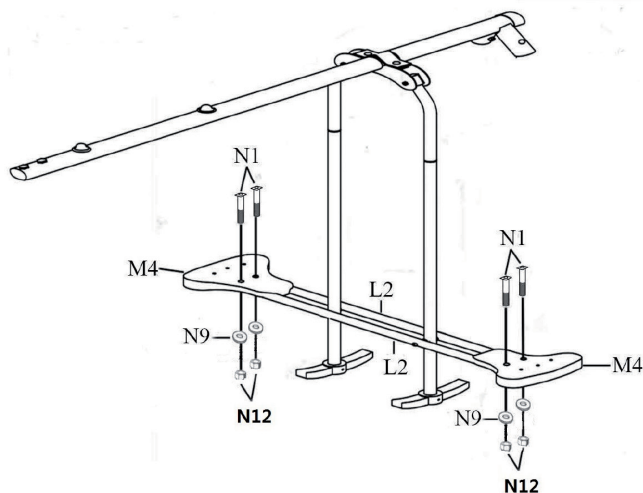

Collegare M4 (sedile) con N1 (bulloni) a N2 (sospensione del sedile).

Stringere il sedile con i pezzi N1 (bulloni), N9 (rondelle) e N12 (dadi).

ANCLAJE

Opcionalmente, puede asegurarse el columpio con anclajes de tierra (no incluidos). La ventaja de anclar con anclaje de tierra es que puede mover el columpio en cualquier momento o colocarlo en un lugar diferente. Este tipo de anclaje es especialmente adecuado para superficies duras.

- Si desea anclar el columpio en un terreno blando, por ejemplo en la arena, utilice un anclaje en espiral (no incluido).
- Si desea anclar el columpio de forma permanente, áncelo en el hormigón. En cualquier caso, asegúrese de que el columpio esté firmemente anclado antes de usarlo.

Atención: Los pies no deben estar a más de 76 mm de profundidad después del anclaje, para asegurar suficiente espacio para balancearse. En cualquier caso, oculte el anclaje y el hormigón para que nadie tropiece con ellos.

Come ancorare l'altalena con ancore a spirale

- Assicurarsi che l'altalena sia su un fondo piano.
- Ruotare l'ancora a spirale nel suolo, fino a quando l'estremità curva si trova attaccata all'apertura in basso sulla gamba.
- Inserire l'estremità curva nell'apertura e fissare la gamba martellando saldamente l'ancora nel suolo.



Come ancorare l'altalena nel cemento

Per incrementare la sicurezza, si consiglia, dove possibile, di ancorare l'altalena nel cemento. Se si posiziona l'altalena su fondi morbidi e instabili, ancorarla assolutamente nel cemento (non incluso in consegna). Seguire questi passaggi:

- Assicurarsi che l'altalena sia su un fondo piano.
- Nei punti in cui si desidera ancorare le gambe, realizzare di fori cilindrici nel cemento. I fori devono essere profondi circa 60 mm e larghi 32 mm. Utilizzare una pala per allargare la parte inferiore dei fori, in modo che il diametro del fondo dei fori sia maggiore dell'apertura in alto (v. immagine). Preparare un letto di ghiaia o pietre alto 51 mm al centro del foro per le gambe dell'altalena (v. immagine).
- Inserire ora le gambe dell'altalena nei fori e riempirli con circa 20,5 kg di cemento.

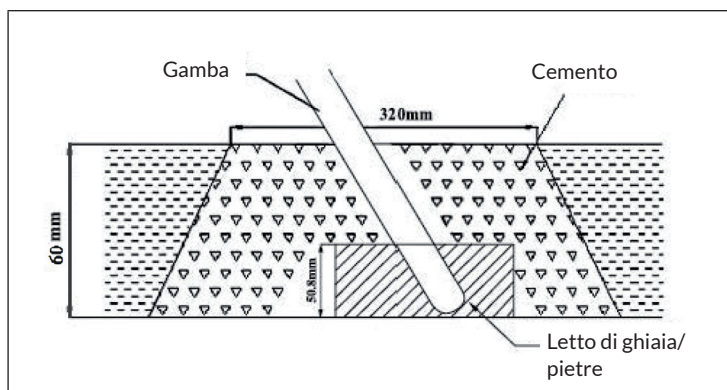

- Coprire il cemento di terra, in modo che nessuno si ferisca.
- Lasciare asciugare per bene il cemento per 6-7 giorni prima di utilizzare l'altalena.
- La distanza tra seduta dell'altalena e suolo deve essere di almeno 350 mm.

PRODUTTORE E IMPORTATORE (UK)

Produttore:

Chal-Tec GmbH, Wallstraße 16, 10179 Berlino, Germania.

Importatore per la Gran Bretagna:

Berlin Brands Group UK Limited

PO Box 42

272 Kensington High Street

London, W8 6ND

United Kingdom

Estimado cliente,

Le felicitamos por la adquisición de este producto. Lea atentamente las siguientes instrucciones y sígalas para evitar posibles daños. No asumimos ninguna responsabilidad por los daños causados por el incumplimiento de las instrucciones y el uso inadecuado. Escanee el siguiente código QR para obtener acceso a la última guía del usuario y más información sobre el producto.



ÍNDICE

Indicaciones de seguridad 64
 Herramientas necesarias 66
 Contenido de la entrega 66
 Montaje 69
 Anclaje 79
 Fabricante e importador (Reino Unido) 81

DATOS TÉCNICOS

Número de artículo	10026906, 10026907
Capacidad de carga máxima	Hasta 45 kg

INDICACIONES DE SEGURIDAD

Indicaciones sobre las restricciones de edad y peso

	<p>El columpio está diseñado para niños de entre 3 y 8 años de edad. El columpio no es adecuado para niños menores de 3 años, ya que podrían lesionarse con piezas pequeñas o cuerdas largas. El columpio no es adecuado para adultos o niños que pesen más de 45 kg.</p>
---	---

Indicaciones generales

- Solamente un niño puede sentarse en el columpio a la vez.
- El columpio está diseñado para uso en el exterior.
- Antes de cada uso, compruebe que todas las tuercas, tornillos y otras piezas estén bien atornilladas; ajústelas más si es necesario.
- Antes de cada uso, revise todas las cubiertas en busca de tornillos y bordes afilados y reemplácelos si es necesario.
- Lubrique regularmente todas las piezas metálicas móviles.
- Revise regularmente el asiento del columpio, las cuerdas y todas las demás partes para ver si están desgastadas. De ser necesario, reemplace las piezas siguiendo las instrucciones del fabricante.
- Revise regularmente el columpio como medida de precaución para detectar signos de desgaste y daños.

Indicaciones sobre el lugar de instalación

- Instale el columpio en una superficie plana y nivelada y conserve una distancia de al menos 2 metros entre el columpio y vallas, garajes, casas, paredes, ramas o cables eléctricos.
- Por motivos de seguridad, ancle el columpio al suelo. Ancle el columpio a ras del suelo o en el suelo para que nadie tropiece con el anclaje.
- Asegúrese de que su hijo no balancee en dirección del sol para evitar que se dañe los ojos por la luz solar directa.
- Para facilitar el montaje, apriete todas las piezas solo a mano al principio. Atornille todas las piezas fuertemente una vez finalizado el montaje.
- No instale el columpio sobre una superficie dura, de hormigón o asfalto.





Indicaciones sobre el uso

- No permita que los niños se columpien de pie.
- Asegúrese de que los niños no se levanten del columpio mientras este esté en movimiento.
- No tuerza las cuerdas ni las envuelva alrededor de la barra superior.
- Asegúrese de que los niños no usen ropa ancha o sudaderas con capucha cuando se columpien, para evitar que se enreden en el columpio con su ropa.
- No permita que los niños trepen por el columpio.
- Asegúrese de que no haya niños jugando cerca del columpio mientras esté este en movimiento.

Indicaciones sobre el montaje y mantenimiento



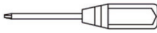

- Para evitar lesiones, siga exactamente las instrucciones de montaje y mantenimiento aquí descritas.
- El material de embalaje no es un juguete. Deseche todo el material de embalaje y asegúrese de que no llegue a las manos de los niños.
- Solamente un adulto debe montar el columpio.
- Los niños podrán llevar a cabo los trabajos de mantenimiento solamente si están bajo la supervisión de un adulto.
- El columpio solo es apto para uso doméstico.
- Una vez que el columpio esté completamente ensamblado, compruébelo cuidadosamente antes de usarlo. Si detecta puntos problemáticos o daños, asegúrese de que nadie use el columpio hasta que estos no se reparen.

HERRAMIENTAS NECESARIAS







			
Martillo	Cinta métrica	Llave Allen (incluida)	LLave (incluida)
			
Destornillador			

CONTENIDO DE LA ENTREGA







Las piezas que se muestra a continuación sirven para el ensamblaje del soporte principal (PCS = pieza):

A1		A1 Tubo superior izquierdo	1 PCS
A2		A2 Tubo superior largo	1 PCS
A3		A3 Sección superior de la pata	4 PCS
A5		A5 Sección inferior de la pata	4 PCS
A6		A6 Soporte transversal	2 PCS

El herraje que se muestra a continuación sirve para el ensamblaje del soporte principal (PCS = pieza):

B1		B1 Tornillo 5/16" * 63 mm	14 PCS
B2		B2 Tornillo 5/16" * 63 mm	4 PCS
B3		B3 Tuerca 5/16"	18 PCS
B4		B4 Tapa de plástico	18 PCS
B5		B5 Arandela	32 PCS
B6		B6 Arandela	4 PCS









Las piezas que se muestra a continuación sirven para el ensamblaje del balancín (PCS = pieza):

L1		L1 Soporte	2PCS
L2		L2 suspensión del asiento	2 PCS
M1		M1 Tapa (montada)	2 PCS
M2		M2 Rodamiento pequeño	2 PCS
M3		M3 Rodamiento grande	4 PCS
M4		M4 Asiento	2 PCS
M5		M5 Reposapiés	2 PCS





El herraje que se muestra a continuación sirve para el ensamblaje del balancín (PCS = pieza):

L4		L4 Terminal	1 PCS
L5		L5 Clip de soporte	1 PCS
L6		L6 Arandela	4 PCS
N3		N3 Tornillo 5/16" * 25 mm	2 PCS
N8		N8 Tuerca 5/16"	2 PCS
N14		N14 Tapa de plástico	2 PCS



El herraje que se muestra a continuación sirve para el ensamblaje del balancín (PCS = pieza):

N1		N1 Perno 1/4" * 35 mm	4 PCS
N2		N2 perno 1/4" * 45 mm	2 PCS
N5		N5 tornillo V6 Ø 5*15	4 PCS
N6		N6 Perno de gancho	2 PCS
N7		N7 Arandela de resorte	4 PCS
N9		N9 Arandela	12 PCS
N11		N11 Tuerca 1/4"	4 PCS
N12		N12 Tuerca	4 PCS

Las piezas que se muestran a continuación sirven para el ensamblaje del asiento (PCS = pieza):

J1		J1 Cadena envainada	4 PCS
J3		J3 Perno de ojo y accesorios	4 PCS
J4		J4 Perno de ojo (montado)	4 PCS
K1		K1 Asiento del columpio	2 PCS

El herraje que se muestra a continuación sirve para el ensamblaje del asiento (PCS = pieza):

J6		J6 Tuerca 5/16"	8 PCS
J8		J8 Arandela	8 PCS
J9		J9 Tapa de plástico	8 PCS

MONTAJE

Notas importantes sobre la instalación

- Coloca el columpio en una superficie recta y nivelada y mantén una distancia de 2 metros alrededor del columpio hasta vallas, ramas colgantes, cables eléctricos, casas u otros objetos.
- No coloque el columpio sobre hormigón, asfalto u otras superficies duras para evitar que los niños se lesionen si se caen.
- No apriete demasiado las tuercas y los tornillos durante la instalación. Esto simplificará el montaje y permitirá que los ajustes se hagan más rápidamente.
- Una vez que haya terminado de montar la unidad, apriete todos los tornillos y tuercas antes de usarla por primera vez.

Montar el columpio

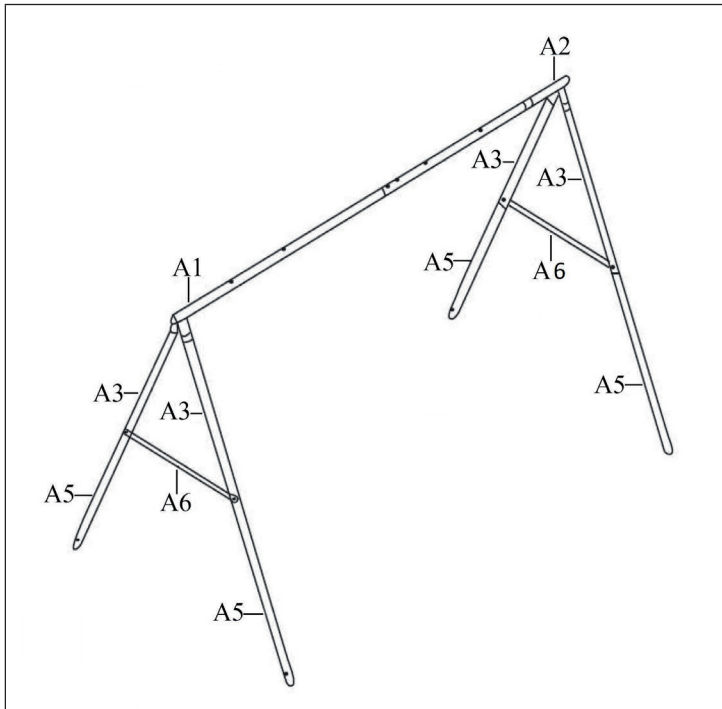

- A1: Tubo superior izquierdo
- A2: Tubo superior largo
- A3: Sección superior de la pata
- A5: Sección inferior de la pata
- A6: Soporte de la cruceta

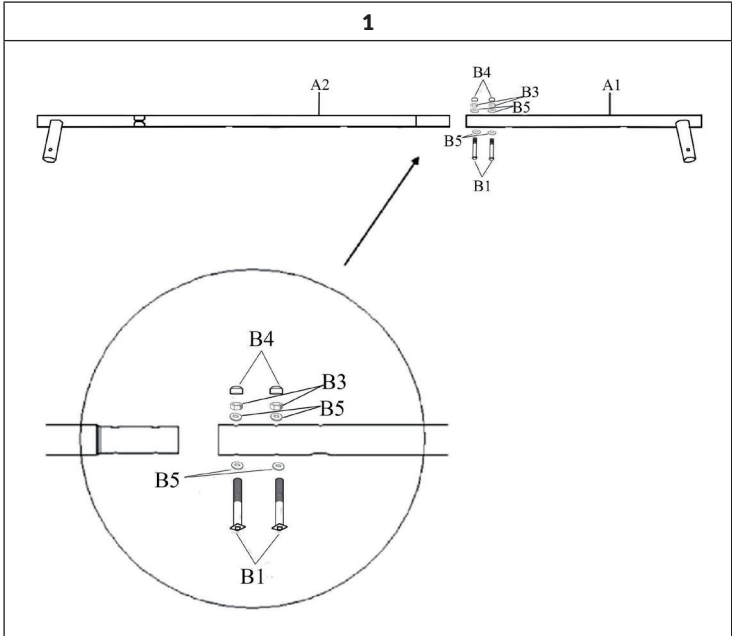

Desliza el A1 (tubo superior izquierdo) sobre el A2 (tubo superior largo) y asegura los tubos con las piezas B1 (pernos), B5 (arandelas), B3 (tuercas) y B4 (tapas de plástico)

Nota: Asegúrese de que el agujero cóncavo esté boca abajo.

2

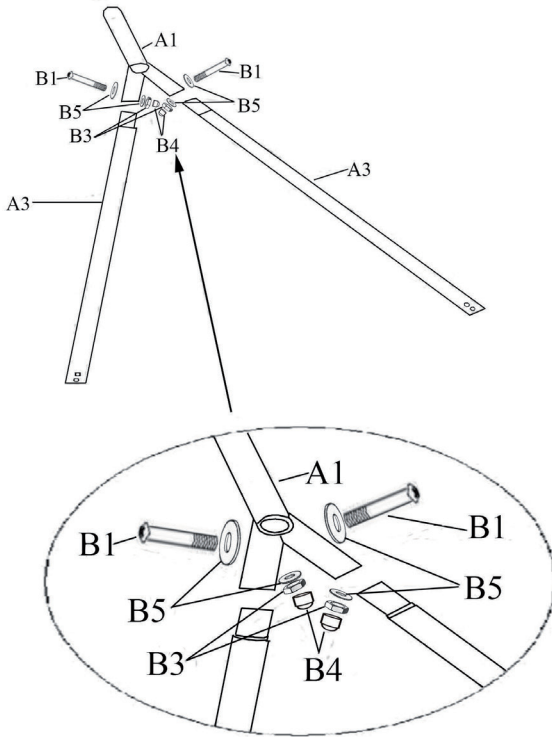

Inserte el extremo corto de A3 (parte superior de la pata) en el hueco del extremo de A1 (parte superior del tubo izquierdo) y alinee los agujeros.

Use la parte B1 (perno) para asegurar, B5 (arandelas), B3 (tuercas) y B4 (tapas de plástico).

Ensamble las otras dos patas superiores de la misma manera a la base del otro lado de A2 (Tubo superior largo).

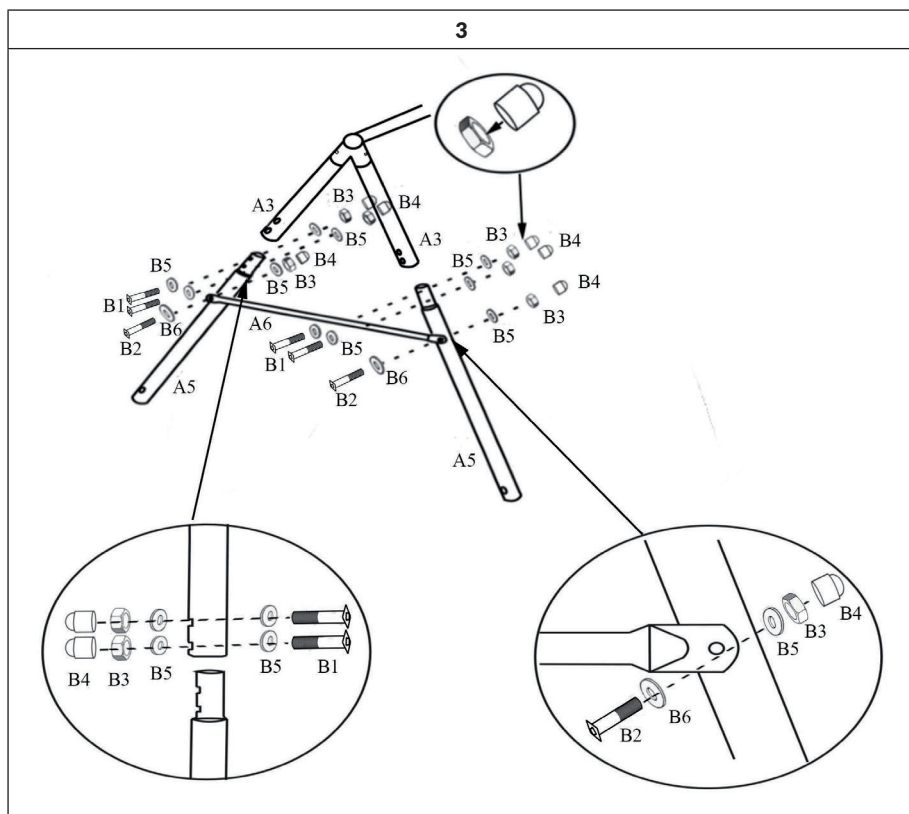

Inserte el extremo de A3 (pata superior) en el hueco de A5 (pata inferior) y alinee los agujeros.

Use la pieza B1 (perno) para asegurarla, B5 (arandelas), B3 (tuercas) y B4 (tapas de plástico).

Deslice A6 (cruceta) en A5 (sección inferior de la pata) y fije la cruceta con las piezas B2 (pernos), B6 (arandelas de resorte), B5 (arandelas), B3 (tuercas) y B4 (tapas de plástico).

Repita los pasos para unir A3 (pata superior), A5 (pata inferior) y A6 (cruceta) al otro lado de A2 (tubo superior largo).

4

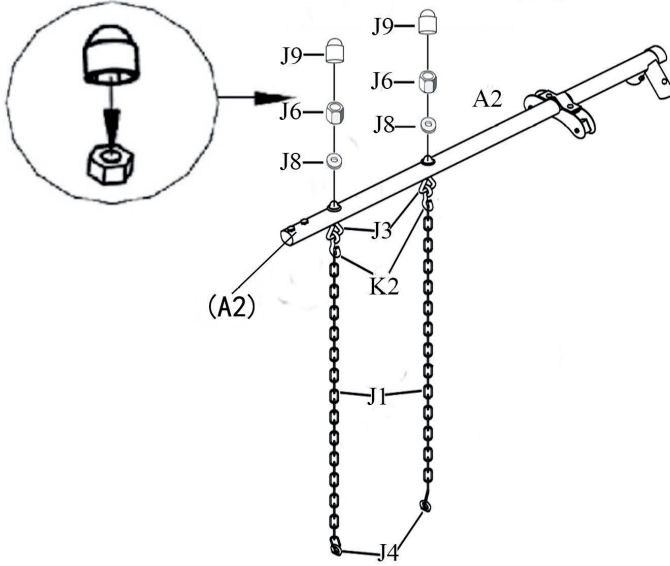

Deslice el J3 (perno y accesorios) a través de los agujeros desde A1 (tubo superior izquierdo) hasta A2 (tubo superior largo).

Asegure los tornillos de ojo con las piezas J8 (arandelas), J9 (tapas plásticas) y J6 (tuercas).

5

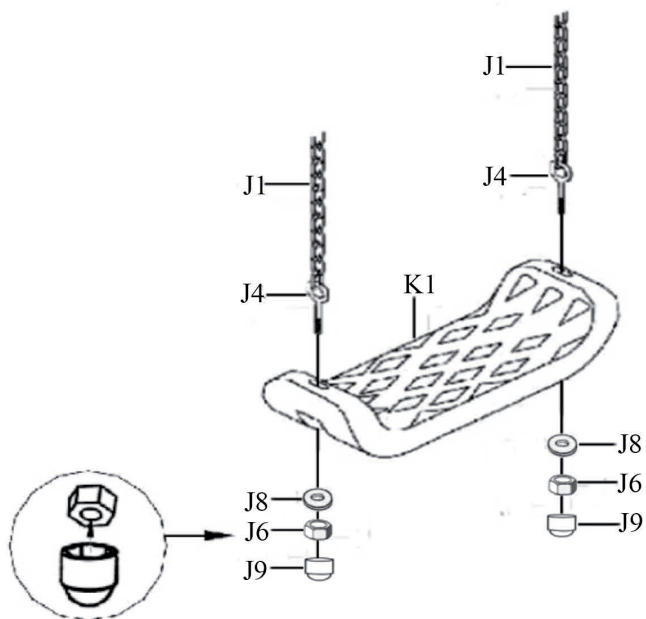

J4 (perno de ojo) y K1 (asiento oscilante) ya están montados.

Si las dos partes no están preensambladas, adjunte J4 y K1 como se muestra en la figura. Utilice las piezas J8 (arandelas), J9 (tapas de plástico) y J6 (tuercas) para asegurarlas.

6

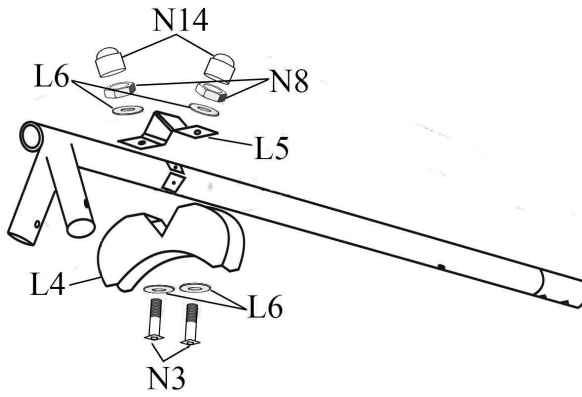

Coloque L5 (clip de soporte), L4 (abrazadera) y L6 (arandelas) en A2 (tubo superior largo) como se muestra en la ilustración.

Luego aprieta N3 (tornillos) y N8 (tuercas) con una llave y un destornillador.

7

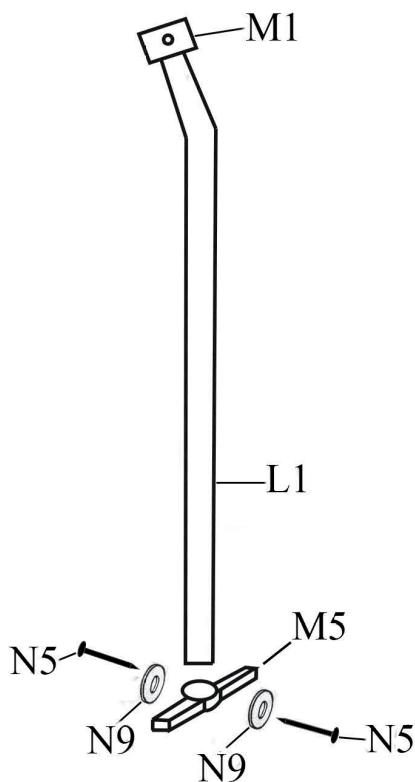

Conecte M5 (reposapiés) y L1 (soporte). Utilice las piezas N5 (tornillos) y N9 (arandelas) para la fijación.

M1 (tapa), M2 (cojinete pequeño) y L1 (soporte) ya están montados. Si las piezas no están preensambladas, coloque M1 sobre L1 y alinee los agujeros. Entonces empuje M2 a través de los agujeros de M1 y L1.

8

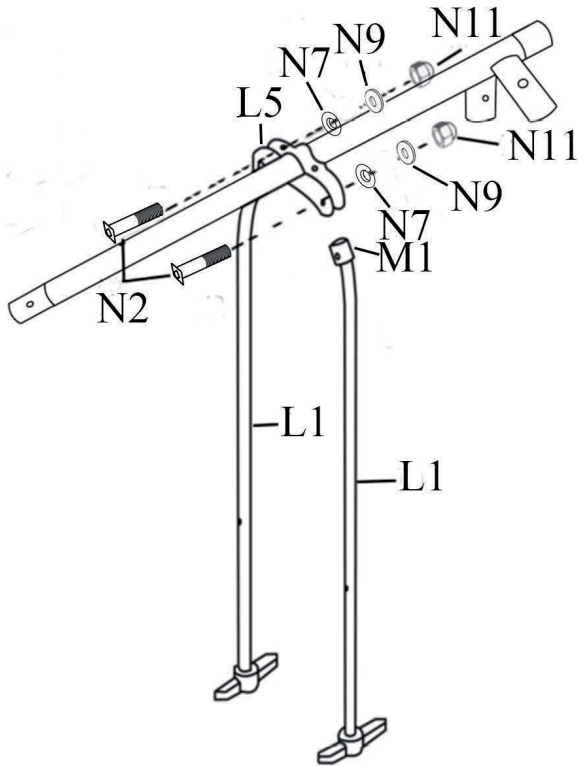

Fije L1 (soporte) en L5 (clip de soporte). Use las piezas N2 (perno), N7 (arandela de resorte), N9 (arandela) y N11 (tuerca).

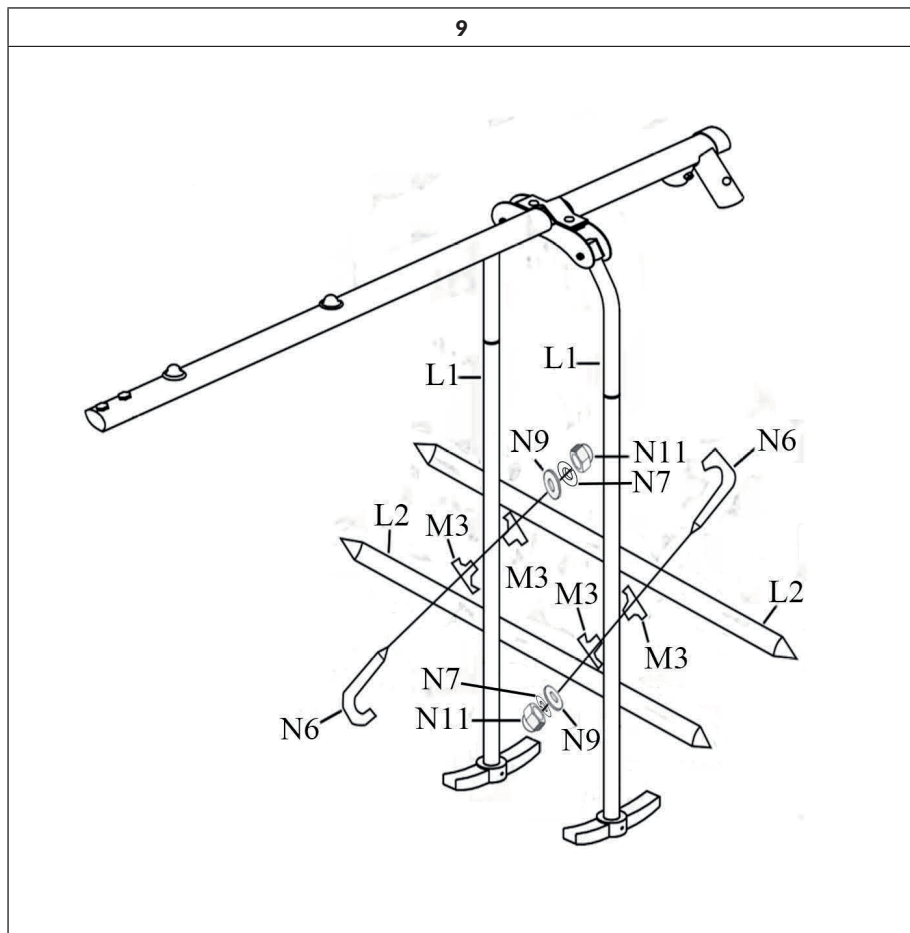

Inserte 2x M3 (rodamiento grande) en L1 (soporte). Entonces ensamble L2 (suspensión del asiento) en L1 (soporte). Utilice las piezas N6 (perno de gancho), N9 (arandelas), N7 (arandelas de resorte) y N11 (tuercas) para la fijación. ¡No apriete las partes completamente todavía!

Abroche la otra suspensión del asiento al soporte de la misma manera. Sólo entonces aprieta todas las partes.

10

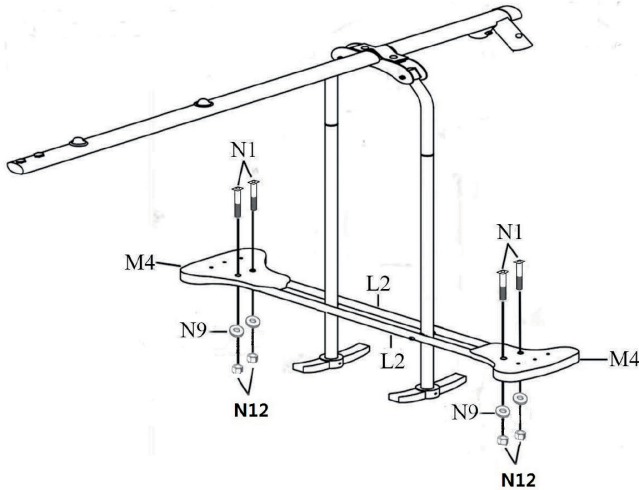

Fije M4 (asiento) con N1 (perno) a N2 (suspensión del asiento).

Asegure el asiento con las piezas N1 (tornillos), N9 (arandelas) y N12 (tuercas).

ANCLAJE

Opcionalmente, puede asegurar el columpio con anclajes de tierra (no incluidos). La ventaja de anclar con anclaje de tierra es que puede mover el columpio en cualquier momento o colocarlo en un lugar diferente. Este tipo de anclaje es especialmente adecuado para superficies duras.

- Si desea anclar el columpio en un terreno blando, por ejemplo en la arena, utilice un anclaje en espiral (no incluido).
- Si desea anclar el columpio de forma permanente, áncelo en el hormigón. En cualquier caso, asegúrese de que el columpio esté firmemente anclado antes de usarlo.

Atención: Los pies no deben estar a más de 76 mm de profundidad después del anclaje, para asegurar suficiente espacio para balancearse. En cualquier caso, oculte el anclaje y el hormigón para que nadie tropiece con ellos.

Anclar el columpio con anclaje en espiral

- Asegúrese de que el columpio está sobre una superficie plana.
- Gire el anclaje en espiral en el suelo hasta que el extremo curvado esté justo encima de la abertura en la parte inferior del pie.
- Inserte el extremo curvado en la abertura y asegure el pie golpeando el ancla firmemente en el suelo con un martillo.



Anclar el columpio con anclaje en el hormigón

Para mayor seguridad, recomendamos anclar el columpio en hormigón si es posible. Si coloca el columpio en un terreno suelto, ancle el marco en hormigón (no incluido). Para ello, siga estos pasos:

- Asegúrese de que el columpio está sobre una superficie plana.
- Cave orificios redondos en el suelo en los lugares donde desea anclar las patas. Los orificios deben ser de 60 mm de profundidad y 32 mm de ancho. Utilice una pala para ampliar la parte inferior del orificio de manera que el diámetro inferior del orificio sea más grande que la abertura superior (véase la ilustración). Coloque una capa de grava o piedra de 51 mm de altura en el centro del agujero para las patas del columpio (ver foto).
- Ahora coloque las patas en los orificios y llénelos con 20,5 kg de hormigón.

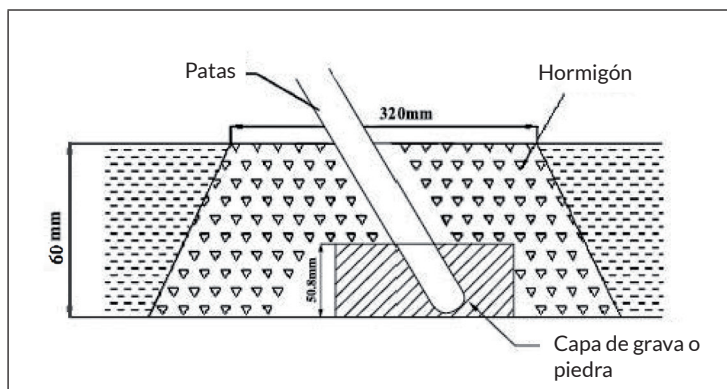

- Cubra el hormigón con tierra, para que nadie se lesione después.
- Deje que el hormigón se seque unos 6-7 días antes de utilizar el columpio.
- La distancia entre la silla y el suelo debe ser de al menos 350 mm.

FABRICANTE E IMPORTADOR (REINO UNIDO)

Fabricante:

Chal-Tec GmbH, Wallstraße 16, 10179 Berlín, Alemania.

Importador para Gran Bretaña:

Berlin Brands Group UK Limited

PO Box 42

272 Kensington High Street

London, W8 6ND

United Kingdom

Chère cliente, cher client,

Toutes nos félicitations pour l'acquisition de ce nouvel appareil. Veuillez lire attentivement et respecter les instructions de ce mode d'emploi afin d'éviter d'éventuels dommages. Nous ne saurions être tenus pour responsables des dommages dus au non-respect des consignes et à la mauvaise utilisation de l'appareil. Scannez le QR-Code pour obtenir la dernière version du mode d'emploi et des informations supplémentaires concernant le produit.



SOMMAIRE

Consignes de sécurité 84
 Outils nécessaires 86
 Contenu de l'emballage 86
 Montage 89
 Ancrage 99
 Fabricant et importateur (UK) 101

FICHE TECHNIQUE

Numéro d'article	10026906, 10026907
Poids total utilisateur maximal autorisé	Jusqu'à 45 kg

CONSIGNES DE SÉCURITÉ

Remarques sur les restrictions d'âge et de poids

	<p>La balançoire est adaptée pour des enfants âgés entre 3-8 ans. La balançoire ne convient pas à des enfants de moins de 3 ans, car ils pourraient se blesser avec les petits éléments ou les longues cordes. La balançoire ne convient pas aux adultes ou aux enfants dont le poids dépasse 45 kg.</p>
---	--

Consignes générales

- Il doit toujours se trouver un seul enfant à la fois sur la balançoire.
- La balançoire est conçue pour une utilisation en extérieur.
- Avant utilisation, vérifiez que tous les écrous, les vis et les assemblages sont bien fixés et resserrez-les si besoin.
- Avant utilisation, vérifiez tous les caches des vis et autres bords coupants et remplacez-les si besoin.
- Lubrifiez régulièrement toutes les parties métalliques mobiles.
- Contrôlez régulièrement le niveau d'usure du siège de la balançoire, de la corde et de toutes les autres pièces. Si nécessaire, remplacez les pièces selon les instructions du fabricant.
- Vérifiez à intervalles réguliers les signes éventuels d'usure ou les dommages de la balançoire.

Consignes sur l'emplacement

- Placez la balançoire sur une surface plane et de niveau à au moins 2 mètres des clôtures, garages, maisons, murs, branches suspendues ou câbles électriques.
- Pour des raisons de sécurité, la balançoire doit être ancrée au sol. Les fixations de la balançoire doivent affleurer ou être dans le sol afin que personne ne trébuche dessus.
- Assurez-vous que votre enfant ne se balance pas face au soleil pour éviter les dommages oculaires causés par la lumière directe du soleil.
- Pour faciliter l'assemblage, serrez d'abord tous les accessoires à la main. Ne serrez pas les pièces avant d'avoir terminé l'assemblage.
- Ne placez pas la balançoire sur du béton, de l'asphalte ou une surface dure.





Consignes d'utilisation

- Assurez-vous que les enfants ne se balancent pas en position debout.
- Assurez-vous que les enfants ne descendent pas de la balançoire en mouvement.
- Ne tordez pas les câbles pivotants et ne les enroulez pas autour de la barre supérieure.
- Assurez-vous que les enfants ne portent pas de vêtements amples, ouverts ou à capuche lorsqu'ils se balancent, afin que les vêtements ne se prennent pas dans la balançoire.
- Assurez-vous que les enfants ne grimpent pas sur la balançoire.
- Assurez-vous que les autres enfants ne jouent pas près de la balançoire pendant son utilisation.

Consignes de montage et d'entretien



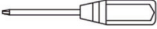

- Afin d'éviter les blessures, suivez précisément les instructions d'installation et d'entretien décrites ici.
- Les matériaux d'emballage ne sont pas des jouets. Jetez immédiatement tous les matériaux et assurez-vous qu'ils ne tombent pas entre les mains des enfants.
- La balançoire ne peut être assemblée que par des adultes.
- L'entretien peut éventuellement être effectué par des enfants sous la surveillance d'un adulte.
- L'appareil est uniquement conçu pour un usage privé.
- Une fois la balançoire entièrement assemblée, vérifiez-la à nouveau soigneusement avant utilisation. Si vous découvrez des problèmes ou des dommages, assurez-vous que personne n'utilise la balançoire jusqu'à ce qu'elle soit à nouveau en état.

OUTILS NÉCESSAIRES







			
Marteau	Mètre à ruban	Clé Allen (fournie)	clé (fournie)
			
Tournevis cruciforme			

CONTENU DE L'EMBALLAGE







Ces pièces sont nécessaires pour le cadre (PCS = pièces) :

A1		tube supérieur gauche	1 PCS
A2		tube supérieur long	1 PCS
A3		partie supérieure du pied	4 PCS
A5		partie inférieure du pied	4 PCS
A6		Barre transversale	2 PCS







Ces accessoires sont nécessaires pour l'assemblage du cadre (PCS = pièces) :

B1		Vis	14 PCS
B2		Vis	4 PCS
B3		Erou	18 PCS
B4		Capuchon en plastique	18 PCS
B5		Rondelle	32 PCS
B6		Rondelle	4 PCS









Les pièces suivantes sont nécessaires pour la balançoire (PCS = pièces) :

L1		Support	2PCS
L2		Suspension de siège	2 PCS
M1		Capuchon (assemblé)	2 PCS
M2		Petit roulement (assemblé)	2 PCS
M3		Grand roulement (assemblé)	4 PCS
M4		Siège	2 PCS
M5		Repose-pieds	2 PCS





Il vous faut les fixations suivantes pour la balançoire (PCS = pièces) :

L4		Fixation	1 PCS
L5		Collier de serrage	1 PCS
L6		Rondelle	4 PCS
N3		Vis	2 PCS
N8		Ecrou	2 PCS
N14		Capuchon en plastique	2 PCS



**Les pièces suivantes sont nécessaires pour la balançoire
(PCS = pièces) :**

N1		Boulon	4 PCS
N2		Vis	2 PCS
N5		Crochet à visser	4 PCS
N6		Rondelle ondulée	2 PCS
N7		Rondelle	4 PCS
N9		Rondelle	12 PCS
N11		Ecrou	4 PCS
N12		Ecrou	4 PCS

Les pièces suivantes sont nécessaires pour l'assemblage du siège de balançoire (PCS = pièces) :

J1		Chaîne gainée	4 PCS
J3		Boulon à œil et accessoires	4 PCS
J4		Boulon à œil (assemblé)	4 PCS
K1		Siège de balançoire	2 PCS

**Diese Zubehörteile benötigen Sie zum Zusammenbau des Schaukelsitzes
(PCS = Stück):**

J6		Ecrou	8 PCS
J8		Rondelle	8 PCS
J9		Capuchon en plastique	8 PCS

MONTAGE

Remarques importantes concernant le montage

- Installez la balançoire sur une surface plane et de niveau et gardez une distance de 2 mètres autour de la balançoire par rapport aux clôtures, aux branches suspendues, aux câbles électriques, aux maisons ou à d'autres objets.
- Ne placez pas la balançoire sur du béton, de l'asphalte ou d'autres surfaces dures, afin que les enfants ne se blessent pas en tombant.
- Ne serrez pas trop les écrous et les boulons pendant le montage. De cette façon, vous simplifiez le montage et pouvez effectuer des réglages plus rapidement.
- Une fois le montage terminé, serrez bien toutes les vis et écrous avant d'utiliser l'appareil pour la première fois.

Assemblage de la balançoire

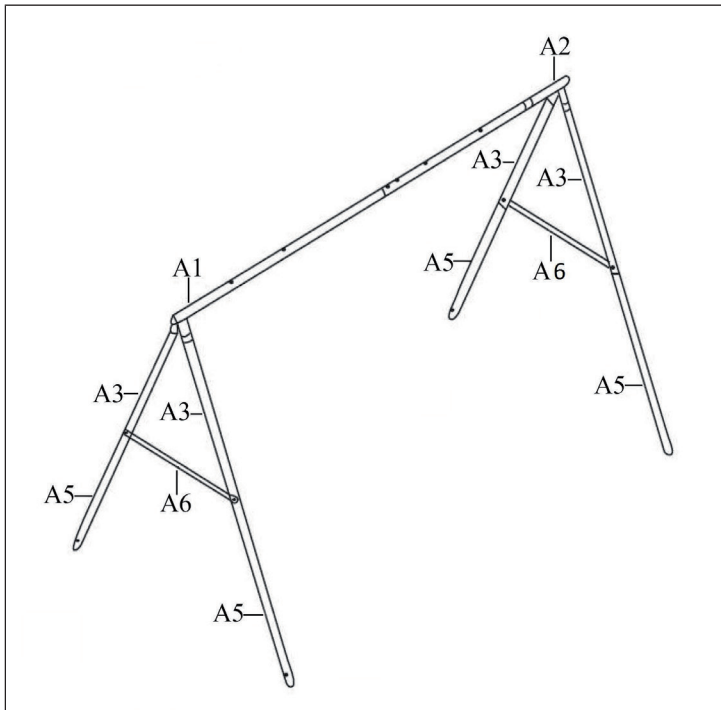

- A1: tube supérieur gauche
 A2: tube supérieur long
 A3: partie supérieure du pied
 A5: partie inférieure du pied
 A6: barre transversale

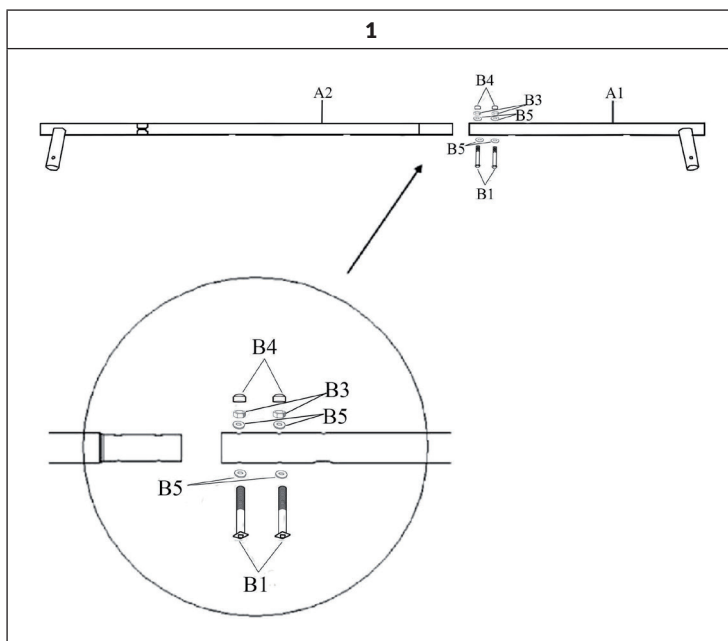

Faites glisser A1 (tube supérieur gauche) sur A2 (tube supérieur long) et fixez les tubes avec les pièces B1 (boulons), B5 (rondelles), B3 (écrous) et B4 (capuchons en plastique)

Remarque : Assurez-vous que le trou concave est orienté vers le bas.

2

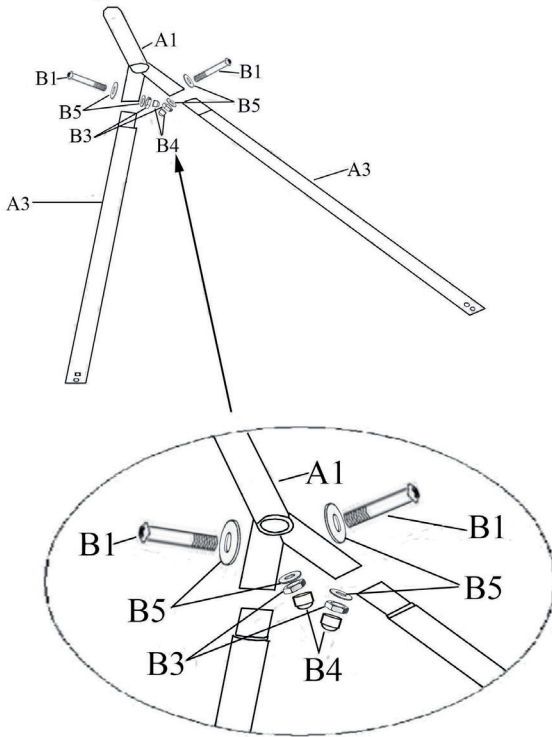

Insérez l'extrémité courte de A3 (partie supérieure du pied) dans la base à l'extrémité de A1 (tube supérieur gauche) et alignez les trous les uns avec les autres.

Utilisez les pièces B1 (boulons), B5 (rondelles), B3 (écrous) et B4 (capuchons en plastique) pour l'assemblage.

Fixez les deux autres parties supérieures de pieds de la même manière à la base de l'autre côté de A2 (tube supérieur long).

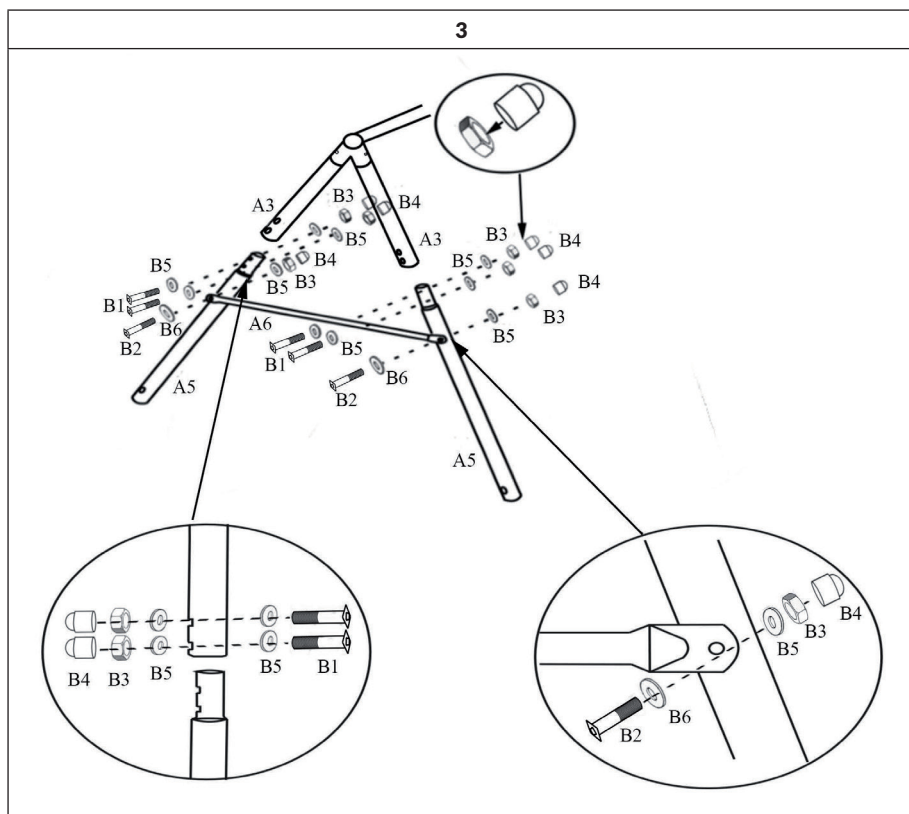

Insérez l'extrémité de A3 (partie supérieure du pied) dans la base de A5 (partie inférieure du pied) et alignez les trous les uns avec les autres.

Utilisez les pièces B1 (boulons), B5 (rondelles), B3 (écrous) et B4 (capuchons en plastique) pour l'assemblage.

Faites glisser A6 (barre transversale) sur A5 (partie inférieure du pied) et fixez la barre transversale avec les pièces B2 (boulons), B6 (rondelles ondulées), B5 (rondelles), B3 (écrous) et B4 (capuchons en plastique).

Répétez les étapes pour fixer A3 (partie supérieure du pied), A5 (partie inférieure du pied) et A6 (barre transversale) de l'autre côté de A2 (tube supérieur long).

4

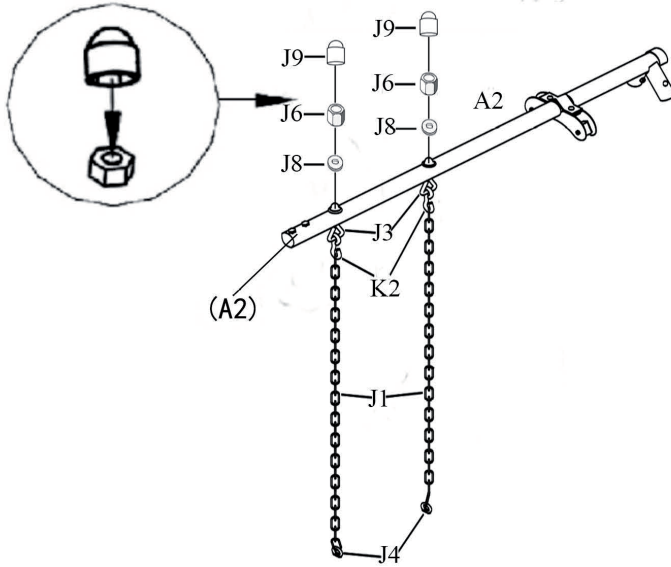

Poussez J3 (boulon à œil et accessoires) à travers les trous de A1 (tube supérieur gauche) à A2 (tube supérieur long).

Fixez les boulons à œil avec les pièces J8 (rondelles), J9 (capuchons en plastique) et J6 (écrous).

5

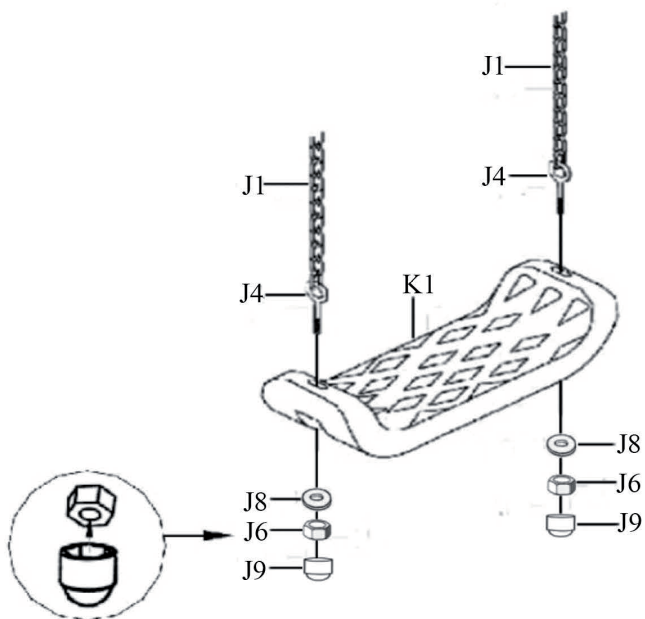

J4 (boulon à œil) et K1 (siège de balançoire) sont déjà montés.

Si les deux pièces ne sont pas pré montées, fixez J4 et K1 comme indiqué sur l'illustration. Utilisez les pièces J8 (rondelles), J9 (capuchons en plastique) et J6 (écrous) pour la fixation.

6

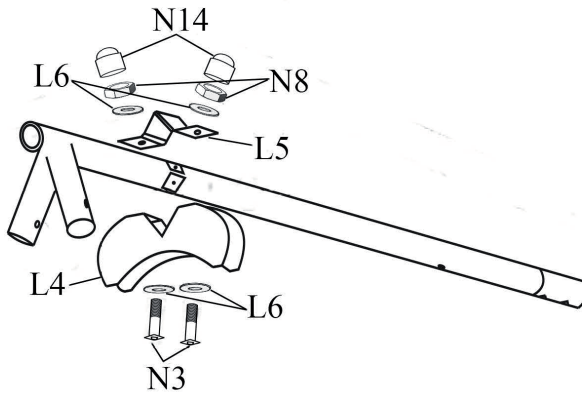

Fixez L5 (collier de serrage), L4 (fixation) et L6 (rondelles) à A2 (tube supérieur long) comme indiqué sur l'illustration.

Serrez ensuite N3 (vis) et N8 (écrous) avec une clé et un tournevis.

7

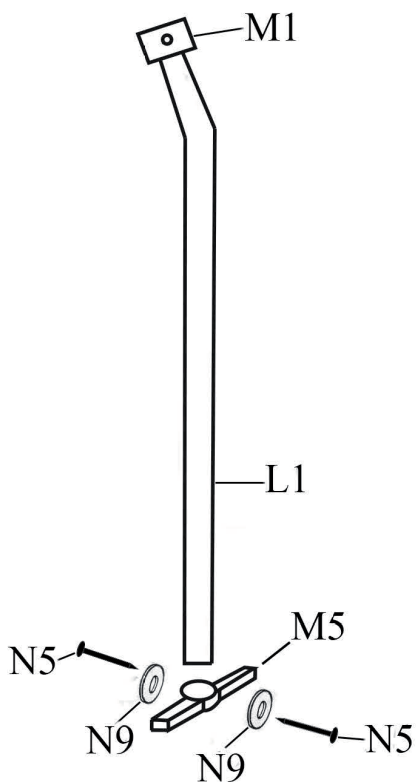

Reliez M5 (repose-pieds) et L1 (support). Utilisez les pièces N5 (vis) et N9 (rondelles) pour la fixation.

M1 (capuchon), M2 (petit roulement) et L1 (support) sont déjà installés. Si les pièces n'ont pas été préassemblées, fixez M1 en haut de L1 et alignez les trous. Faites ensuite glisser M2 à travers les trous de M1 et L1.

8

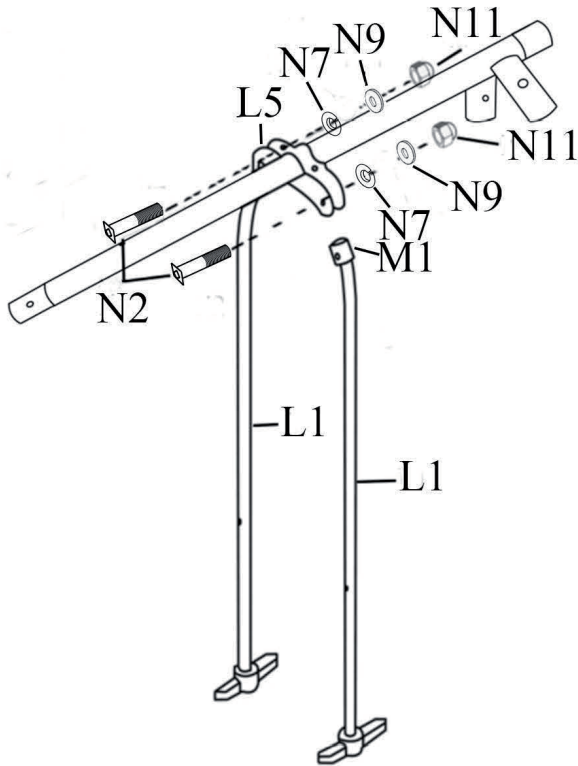

Fixez L1 (support) à L5 (collier de serrage). Utiliser les pièces N2 (boulon), N7 (rondelle ondulée), N9 (rondelle) et N11 (écrous) pour la fixation.

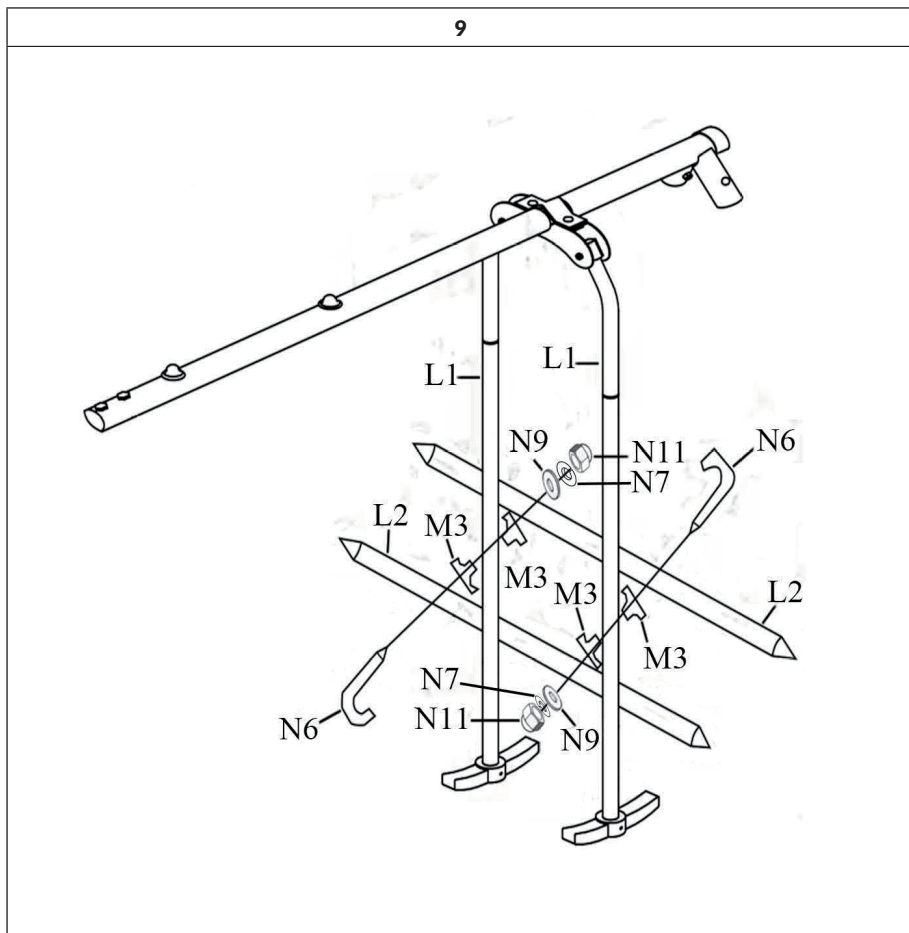

Insérez 2x M3 (grand roulement) dans L1 (support). Fixez ensuite L2 (suspension du siège) à L1 (support). Utilisez les pièces N6 (crochet à visser), N9 (rondelles), N7 (rondelles ondulées) et N11 (écrous) pour la fixation. Mais ne serrez pas encore complètement les pièces !

Fixez l'autre suspension du siège au support de la même manière. Ensuite, serrez toutes les pièces.

10

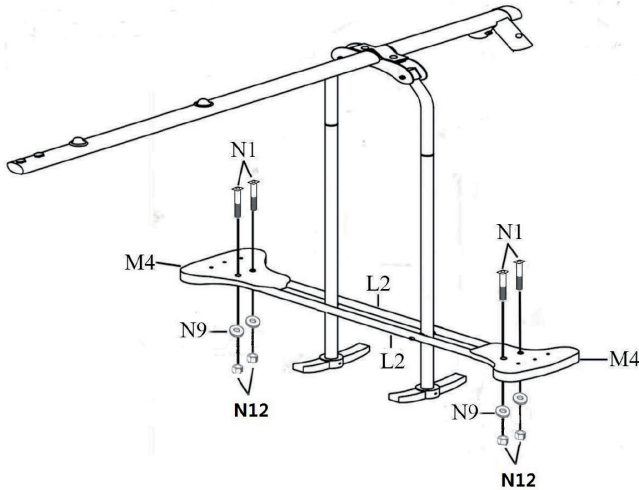

Fixez M4 (siège) à N2 (suspension du siège) à l'aide de N1 (boulon).

Fixez le siège avec les pièces N1 (boulons), N9 (rondelles) et N12 (écrous).

ANCRAGE

En option, vous pouvez sécuriser la balançoire avec des ancrages au sol (non inclus). L'avantage de l'ancrage au sol est que vous pouvez déplacer le jeu à tout moment ou le changer d'emplacement. Ce type d'ancrage est particulièrement adapté aux sols durs.

- Si vous ancrez la balançoire sur un sol mou, par ex. dans du sable, utilisez une ancre en spirale (non incluse).
- Si vous souhaitez sécuriser la balançoire de façon permanente, ancrez-la dans du béton. Dans tous les cas, assurez-vous que la balançoire est fermement ancrée avant de l'utiliser.

Remarque : Après l'ancrage, les pieds ne doivent pas être enfouis à plus de 76 mm dans le sol pour qu'il y ait encore suffisamment d'espace pour se balancer. En tout cas, enfouissez les ancrages et le béton pour que personne ne trébuche dessus.

Comment ancrer la balançoire avec des ancres en spirale

- Assurez-vous que la balançoire est sur une surface plane.
- Tournez l'ancre en spirale dans le sol jusqu'à ce que l'extrémité coudée soit juste au-dessus de l'ouverture au bas des pieds.
- Insérez l'extrémité incurvée dans l'ouverture et fixez le pied en enfonçant bien l'ancre dans le sol avec un marteau.



Comment ancrer la balançoire dans du béton

Pour augmenter la sécurité, nous vous recommandons d'ancrer la balançoire dans du béton si possible. Si vous installez la balançoire sur une surface meuble, ancrez toujours le cadre dans du béton (non inclus dans la livraison). Pour ce faire, suivez les étapes ci-dessous :

- Assurez-vous que vous placez la balançoire sur une surface plane.
- Creusez des trous cylindriques dans le sol où vous souhaitez ancrer les pieds. Les trous doivent avoir une profondeur d'environ 60 mm et une largeur de 32 mm. Utilisez une pelle pour agrandir la partie inférieure du trou de sorte que le diamètre inférieur du trou soit plus grand que l'ouverture supérieure (voir l'image). Au milieu du trou, préparez un lit de gravier ou de pierre de 51 mm de haut pour les pieds de la balançoire (voir l'illustration).
- Maintenant, mettez les pieds de la balançoire dans les trous et remplissez les trous avec environ 20,5 kg de béton.

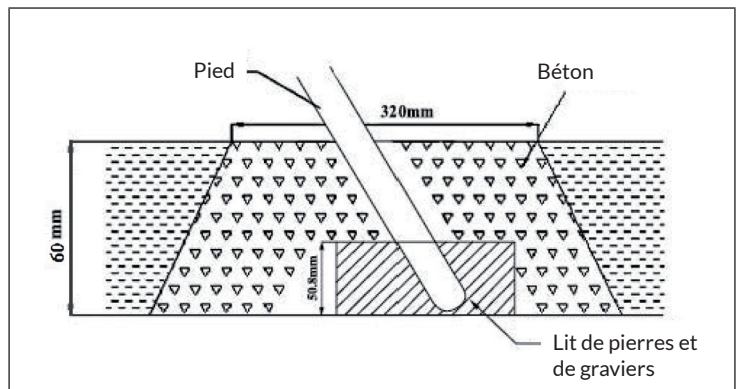

- Couvrez le béton de terre pour que personne ne se blesse plus tard.
- Laissez bien sécher le béton pendant 6-7 jours avant d'utiliser la balançoire.
- La distance du siège de balançoire au sol doit être d'au moins 350 mm.

FABRICANT ET IMPORTATEUR (UK)

Fabricant :

Chal-Tec GmbH, Wallstraße 16, 10179 Berlin, Allemagne.

Importateur pour la Grande Bretagne :

Berlin Brands Group UK Limited

PO Box 42

272 Kensington High Street

London, W8 6ND

United Kingdom

