



GARAGE DOOR OPENER EXTENSION KIT

MODEL: 425-1600

www.gdohelp.com

1-877-GDO-4402

1-877-436-4402

2301 Traffic St. NE
Minneapolis, MN 55413

WARNING

To prevent **SERIOUS INJURY** or **DEATH**:

- DO NOT connect power until instructed.
- CLOSE the door before installation.



Kit Inventory

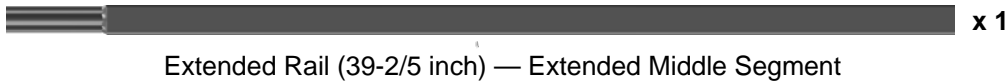

Master Link Set
(Including 1x spare set)

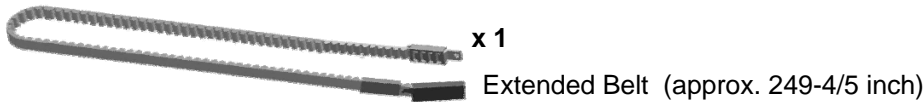

Components Required from Opener Inventory



Trolley Shaft



Rail — Middle Segments x2



Rail — End Segment with Trolley Stop Bolt



Discard 1 Middle Segment (25-3/5 inch)

STEP 1. To Assemble Rail with “Extended Middle Segment”

Please refer to “Rail and Trolley Assembly” in Owner’s Manual.

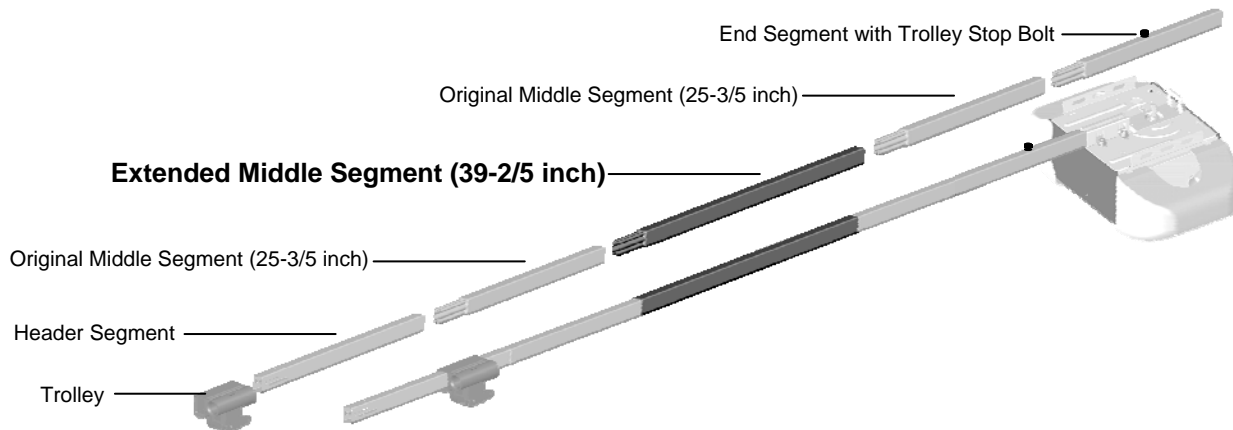

Replace ONE of the original rail Middle Segment with the “Extended Rail Segment” in the middle of rail assembly.

WARNING

- Discard ONLY ONE of the original MIDDLE rail segment.
- ONLY 5 pieces of rail segment should be applied. NEVER connect extra rail segments.
- The opener only services door to max. of 8 FT. height. Door with other size please call service before installation.

Step 2. Installing the Belt

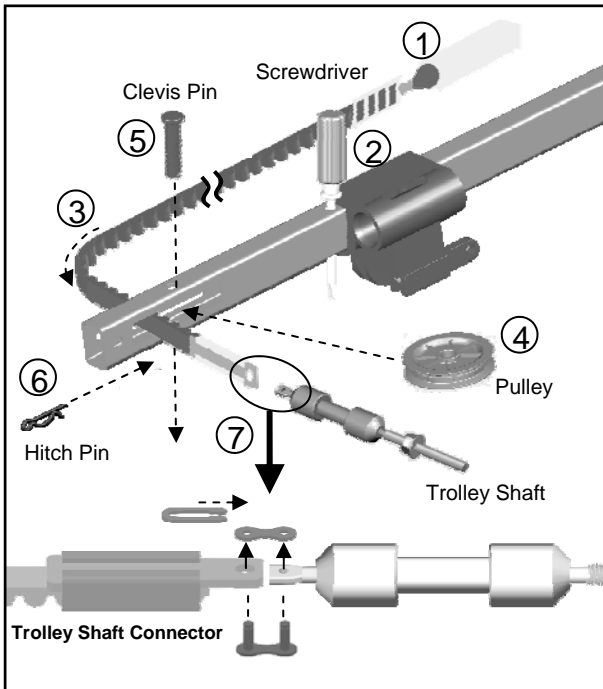

1. Place the belt beside the rail as shown
2. Temporary insert a screwdriver to the hole on the rail apart from the slot, slide the trolley to the screw driver and keep the position.
3. Grasp the end with Trolley-Shaft Connector and pass through the slot on the Header Segment of the rail.
4. Insert the Pulley into the slot while the belt is hanging.
5. Secure the Pulley by inserting the 3/8" x 1-3/4" Clevis Pin through the top of the rail.
6. Lock the Clevis Pin with a Hitch Pin. Rotate the Pulley to ensure it spins smoothly.
7. Connect the Trolley Shaft to the Trolley Shaft Connector on the belt, using the Master Link Set.

Step 3. Proceeding with Installation of Opener

The Rail Assembly Extension with has now been finished.

Please proceed installation of opener starting with **"Installing the Belt"** in Owner's Manual.