

USER GUIDE

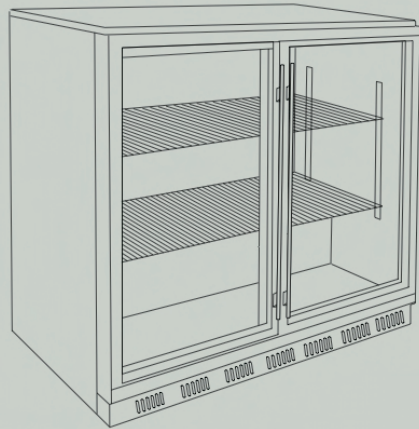
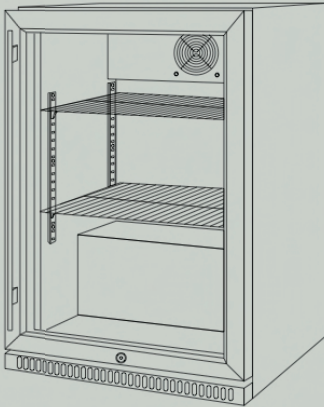

AOF1SM5

AOF2SM5

AOF1BM5

AOF2BM5

Welcome to the world of simple handling and no worries

Thank you for buying this backbar cooler. It has been designed and manufactured for many years of trouble-free service.

Operation is very simple, but please take a few minutes to read this booklet.

WARNING: Keep clear of obstruction all ventilation openings in the appliance enclosure or in the structure for building-in or stationary.

Safety



Attention!

RISK OF ELECTRICAL SHOCK HAZARD

This unit must be earthed.

If the power cable is damaged, it must be replaced by the manufacturer, its service agent or similarly qualified persons in order to avoid hazard. Ensure that the appliance is properly earthed. Stop using the appliance immediately if electric shock is felt when touching the chiller.

DISPOSAL OF OLD APPLIANCES

BE SURE TO MAKE ANY LOCKS UNUSABLE, REMOVE ANY DOOR(S) AND DISCARD SEPARATELY.

WARNING-CHEMICAL HAZARD: DO NOT ALLOW CHILDREN TO PLAY WITH THE OLD APPLIANCE. CONTACT YOUR LOCAL AUTHORITY FOR DISPOSAL PROCEDURES.

Before disposing of an old appliance, please make sure it is switched off and safe.

This appliance is not intended for use by persons (including children) with reduced physical, sensory or mental capabilities, or lack of experience and knowledge, unless they have been given supervision or instruction concerning use of the appliance by a person responsible for their safety.

Children should be supervised to ensure that they do not play with the appliance

Please note: the refrigeration system contains gas and refrigerants which require specialist waste disposal. The valuable materials in a backbar cooler can be recycled. Contact your local waste disposal depot for proper disposal of an old appliance and contact your local authority or dealer if you have any questions.

Please ensure the pipework of your backbar cooler is not damaged prior to disposal. You can contribute to environmental awareness by insisting on an appropriate non-polluting method of disposal.

- Do not obstruct or cover the ventilation aperture.
- Do not position this appliance with its rear panel directly against a wall. Maintain a gap of at least 50mm between the appliance and any adjacent wall.
- Position the chiller away from heat sources, where the unit is well-ventilated and protected from moisture, or extremes of heat or cold. The backbar cooler may not function properly if the temperature rises above +30°C (standard model)
- Do not allow children to play with the appliance, or to sit on it or to hang onto the doors.
- Make sure there is a suitable power Outlet with proper grounding to power the backbar cooler.
- Do not store explosive substances such as aerosol cans with a flammable propellant in this appliance.
- **WARNING:** Ensure all vents are clear of obstruction particularly if the unit is built-in or stationary.
- **WARNING:** Do not damage the refrigerant circuit.
- **WARNING:** Do not use electrical appliances inside the food storage compartments of the appliance, unless they are of the type recommended by the manufacturer.

BEFORE USING FOR THE FIRST TIME

Do not position this appliance with its rear panel directly against a wall. For good circulation and operating efficiency, the ventilation grilles must never be blocked. Remove all packaging and place the chiller on a stable, secure flat surface. Position the chiller away from heat sources, where the unit is well-ventilated and protected from moisture, or extremes of heat or cold.

NEVER USE AN EXTENSION LEAD. If the mains cable will not reach the nearest socket, either rearrange your store layout or ask a qualified electrician to fit a new socket.

If power is cut off, wait for at least 5 minutes before plugging the unit in again to avoid damaging the compressor. **IMPORTANT:** allow the backbar cooler to stand upright for 8 hours before plugging in. Do not place combustible, explosive or volatile articles, corrosive acid or alkali, or liquid in glass containers into the chiller. Always exercise caution if adjusting the temperature.



IMPORTANT: allow the backbar cooler to stand upright for 8 hours before plugging in.



Shelf maximum load is 27KG

OPERATION

Place the shelves firmly on their supports. Check that the backbar cooler is functioning properly before installing and filling it. An optional light switch is inside the unit. Never put warm or hot foods directly into the chiller.

IMPORTANT

- The fridge will go through a normal periodical defrosting cycle, and a manual defrosting operation is only required in most extreme cases. It is better to avoid if not necessary.
- While in the 'defrost' mode, the fridge cooling power is reduced, as the compressor is not working. The automatic cycles ensure the defrosting is done in the most efficient manner, and when required. It is not recommended to leave the fridge in the manually set defrost mode for prolonged periods of time.



NOTE: Do not recommend to operate the fridge on setting that run below 4°C/MAX, as such setting will cause content at the rear of the fridge close to evaporator to freeze, and will result in unnecessary strain on the cooling systems, and undue high energy consumption.



NOTE: In normal operation the controller turns the compressor off at the set temperature, and back on after the temperature had risen by around 5°C.







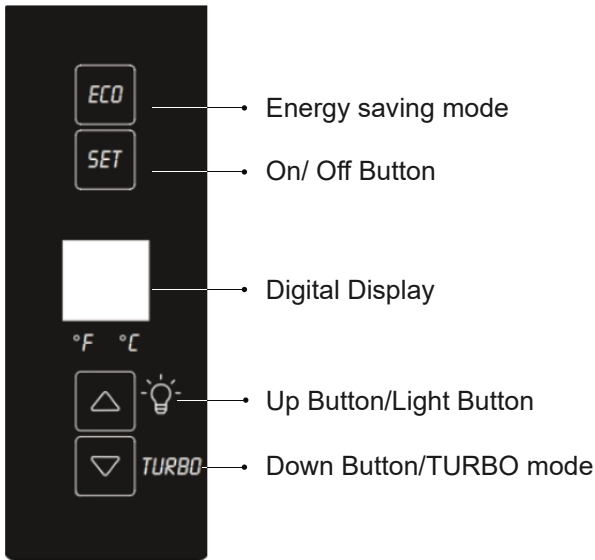

As such, the reading in the electronic controller is almost always a few degrees above set-point, and that is perfectly OK.

Maintenance



Note: The fridge is built to automatically defrost and prevent any ice forming on the Evaporator. When in a 'Defrost' cycle, the indicator light will illuminate under the 'Defrost' symbol:



1.  --Press the “ECO” key to enter or exit energy saving mode.
2.  --Press the “SET” key enter or exit temperature set mode,display screen flash show the set temperature,then press “” or “” could increase or decrease temperature;if no else operation is performed, screen will display the set temperature after 6 seconds.
3.  Up Button/Light Button--Press the  key,control the light on or off.
4.  Down Button/TURBO--Press  key 3 seconds,enter or exit TURBO

WARNING: Do not use mechanical devices or other means to accelerate the defrosting process, other than those recommended by the manufacturer.

LOOKING AFTER THE PRODUCT-DEFROSTING:

Ice may build up on the evaporator if the unit put to work constantly for a period of time.

When ice begins to build up to approx 10mm or 1/5 inch thick, defrost is required.

Empty the cabinet of the products that must stay at cold condition. Switch the thermostat to 'OFF' position.

The ice will start to melt. When the ice has melted and drained away, dry off any residual moisture with a soft cloth.

Switch on the power again via thermostats.

Please note it will take around 12 hours for the cabinet to get back down to temperature with the products.

CLEANING

1. UNPLUG your chiller and remove any stock to a suitable back-up chiller.
2. Wash the inner compartment with warm water and neutral detergent. DO NOT allow the control panel, cables or plug to get wet.
NEVER use corrosive detergents, wire brushes, or abrasive to clean your chiller.
NEVER use metal or sharp implements to remove debris.
3. Dry all surface thoroughly.
4. To ensure trouble-free operation the condenser should be cleaned every three months where appropriate using a vacuum hose. The condenser is located behind lower grill of the cabinet. In exceptionally dusty locations the condenser should be cleaned more often.
5. Use mild soapy water to clean the gasket and seals.

CLIMATIC CLASS MEANING AS BELOW

Test room climate class	Dry bulb temperature °C	Relative humidity %	Dew point °C	Water vapour mass in dry air g/kg
0	20	50	9.3	7.3
1	16	80	12.6	9.1
2	22	65	15.2	10.8
3	25	60	16.7	12.0
4	30	55	20.0	14.8
5	40	40	23.9	18.8
6	27	70	21.1	15.8
7	35	75	30	27.3
8	24	55	14.4	10.2



Built-In or Freestanding Installation: Your backbar cooler can be used as a freestanding or a built in unit. The clearances shown in the drawing below should be followed for both types of installation.

- In particular, the depth dimension must be observed.

IMPORTANT: The vent at the base of the appliance is for ventilation. Nothing should be placed in front of this vent; otherwise your backbar cooler may not operate properly.

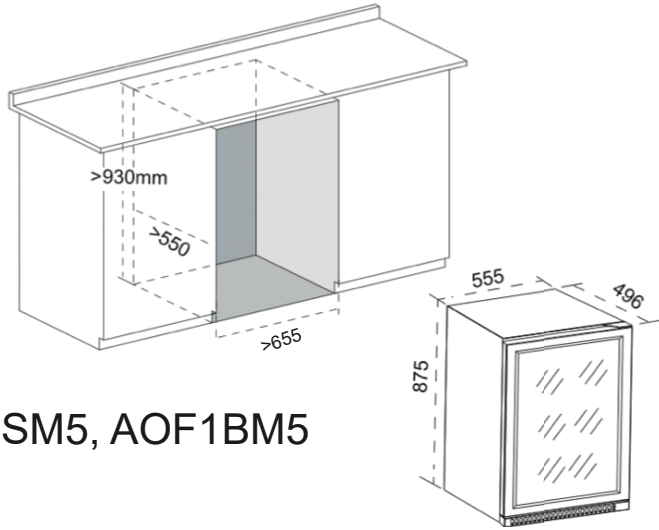

AOF1SM5, AOF1BM5

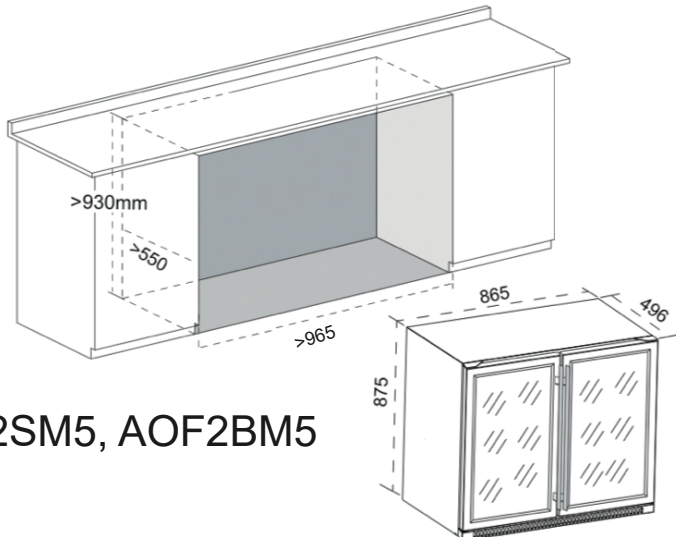

AOF2SM5, AOF2BM5

- The power plug should be placed in a visual position to facilitate operation



Symbol-ISO-7010-W021-Warning; Risk of fire / flammable materials

WARNING: When positioning the appliance, ensure the supply cord is not trapped or damaged.

WARNING: Do not locate multiple portable socket-outlets or portable power supplies at the rear of the appliance.

Warranty Card

artusi.com.au

Worldwide Appliances Pty Limited

A.B.N. 45868077422

Distributed by Eurolinx Pty Ltd

Office:

48-50 Moore Street, Leichhardt N.S.W 2040

Post:

Locked Bag 3000, Annandale, N.S.W 2038

P: 1300 694 583

WARRANTY REGISTRATION

Your ongoing satisfaction with your artusi product is important to us. We ask that you complete the enclosed Warranty Registration Card and return it to us so that we have a record of the artusi product purchased by you.

PRIVACY

Worldwide Appliances respects your privacy and is committed to handling your personal information in accordance with the National Privacy Principles and the Privacy Act 1988 (Cth). A copy of the Worldwide Appliances Privacy Policy is available at www.artusi.com.au. Worldwide Appliances will not disclose any personal information set out in the Warranty Registration Card ("Personal Information") without your consent unless required by:

1. law;
2. any Worldwide Appliances related company;
3. any service provider which provide services to artusi or assist artusi in providing services (including repair and warranty services) to customers. Our purpose in collecting the Personal Information is

to keep a record of the artusi product purchased by you, in order to provide a better warranty service to you in the unlikely event that there is a problem with your artusi product. Worldwide Appliances may contact you at any one or more of the address, email address or telephone numbers set out in the Warranty Registration Card. Please contact artusi on 1300 694 583 should you not wish to be contacted by Worldwide Appliances.

WARRANTY

1. Warranty

Worldwide Appliances warrants that each artusi product will remain, for a period of either 12 months or 24 months of warranty. All Warranties are valid from the original date of purchase, And warranty claims must be accompanied by the proof of purchase.

24 months warranty products:

All Built-in Appliances – Limited to Ovens, Gas, Induction and Electric Cooktops, and All Ranges. Freestanding Cookers - Gas and Electric Models (900mm Width).

Dishwashers - Freestanding, Fully Integrated, Semi Integrated and built-in. All Wine coolers. All Dryers. Freestanding Cookers - Gas and Electric Models in 50cm, 54cm and 60cm Widths

Portable Appliances* – Benchtop Models and Portable Gas Models

2. What is not Covered by the Warranty.

The Warranty does not apply if an artusi product is defective by a factor other than a defect arising in the manufacture of the artusi product, including but not limited to:

- (a) damage through misuse (including failure to maintain, service or use with proper care), neglect, accident or ordinary wear and tear (including deterioration of parts and accessories and glass breakage);
- (b) use for purpose for which the artusi product was not sold or designed;
- (c) use or installation which is not in accordance with any specified instructions for use or installation;
- (d) use or operation after a defect has occurred or been discovered;
- (e) damage through freight, transportation or handling in transit (other than when Worldwide Appliances is responsible);
- (f) damage through exposure to chemicals, dusts, residues, excessive voltage, heat, atmospheric conditions or other forces or environmental factors outside the control of Worldwide Appliances;
- (g) repair, modification or tampering by the purchaser or any person other than Worldwide Appliances, an employee of Worldwide Appliances or an authorised artusi service contractor*;
- (h) use of parts, components or accessories which have not been supplied or specifically approved by artusi.
- (i) damage to surface coatings caused by cleaning or maintenance using products not recommended in the artusi product handbook provided to the purchaser upon purchase of the artusi product;
- (j) damage to the base of an electric oven due to items having been placed on the base of the oven cavity or covering the base, such as aluminium foil (this impedes the transfer of heat from the element to the oven cavity and can result in irreparable damage); or
- (k) damages, dents or other cosmetic imperfections not affecting the performance of the artusi in respect of an artusi product purchased as a "factory second" or from display

The Warranty does not extend to light globes used in artusi products.

3. Domestic Use

Each artusi product is made for domestic use. This Warranty may not extend to artusi products used for commercial purposes.

Continued over...

4. Time for Claim under the Warranty

You must make any claim under this Warranty within twenty eight (28) days after the occurrence of an event which gives rise to a claim pursuant to the Warranty, by booking a service call on the telephone number below.

5. Proof of Purchase

Customers must retain proof of purchase in order to be eligible to make a warranty claim in respect of an artusi product.

6. Claiming under the Warranty

Customers will bear the cost of claiming under this Warranty unless Worldwide Appliances determines the expenses are reasonable, in which case the customer must claim those expenses by providing written evidence of each expense to Worldwide Appliances at the address on the Warranty Registration Card.

7. Statutory Rights

(a) These terms and conditions do not affect your statutory rights.

(b) The limitations on the Warranty set out in this document do not exclude or limit the application of the consumer guarantees set out in the Act or any other equivalent or corresponding legislation in the relevant jurisdiction where to do so would:

(i) contravene the law of the relevant jurisdiction; or

(ii) cause any part of the Warranty to be void.

(c) Worldwide Appliances excludes indirect or consequential loss of any kind (including, without limitation, loss of use of the artusi product) and (other than expressly provided for in these terms and conditions) subject to all terms, conditions and warranties implied by custom, the general law, the Act or other statute.

(d) The liability of Worldwide Appliances to you

for a breach of any express or non-excludable implied term, condition or warranty is limited at the option of Worldwide Appliances to:

(i) replacing or repairing the defective part of the artusi product;

(ii) paying the cost of replacing or repairing the defective part of the artusi product;

(iii) replacing the artusi product; or

(iv) paying the cost of replacing the artusi product.

(e) Our goods come with guarantees that cannot be excluded under the Australian Consumer Law. You are entitled to a replacement or refund for a major failure and for compensation for any other reasonably foreseeable loss or damage. You are also entitled to have the goods repaired or replaced if the goods fail to be of acceptable quality and the failure does not amount to a major failure.

8. Defects

Any part of an artusi product deemed to be defective and replaced by Worldwide Appliances is the property of Worldwide Appliances.

Worldwide Appliances reserves the right to inspect and test artusi products in order to determine the extent of any defect and the validity of a claim under the Warranty.

All warranty service calls must be booked via the customer care department. The team can be contacted on 1 300 85 64 11 option 1 or customercare@eurolinx.com.au

01082016

**DON'T FORGET TO REGISTER
YOUR WARRANTY ONLINE
NOW AT www.eurolinx.support**



**TO REGISTER
YOUR WARRANTY**



FOLLOW US ON:



[/artusi_kitchen_laundry_outdoor](https://www.instagram.com/artusi_kitchen_laundry_outdoor)



[/au.linkedin.com/company/euroilnx-ptyltd](https://www.linkedin.com/company/euroilnx-ptyltd)

[artusi.com.au](https://www.artusi.com.au)

Australia National Telephone Number 1300 694 583

Our showrooms opening hours in each state are available on our website

NSW & ACT (Head Office)

48-50 Moore Street
Leichhardt

Victoria

27/131 Church Street
Hawthorn

QLD

Contact
head office

WA & NT

Contact
head office

DISCLAIMER

Worldwide Appliances PTY LTD, trading as ARTUSI, is continually seeking ways to improve the design specifications, aesthetics and production techniques of its products. As a result alterations to our products and designs take place continually. Whilst every effort is made to produce information and literature that is up to date, this brochure should not be regarded as an infallible guide to the current specifications, nor does it constitute an offer for the sale of any particular product. Product dimensions indicated in our literature is indicative only. Actual product only should be used to define dimension cutouts. Distributors, and retailers are not agents of ARTUSI and are not authorised to bind ARTUSI by any express or implied undertaking or representation.