

SERVER

• E S S E N T I A L S •

ConserveWell®

DROP-IN UNIT

MODEL: CW-DI

UNIT 87760

120V USA

UNIT 87770

120V USA

Programmable Timer



Thank You

for purchasing our ConserveWell® Drop-In Heated Utensil Holder. This unit holds serving utensils above 140°F, keeping them safe while saving water, energy and money.

SAVE WATER. SAVE MONEY.

SETUP

YOU WILL NEED:
Phillips-head Screwdriver



YOU MAY NEED:
Appropriate personnel and
tools to cut countertop hole(s)



PRACTICE SAFETY. WASH PAN & PAN LINER PROPERLY BEFORE USE. See pages 8 & 9.

1 SELECT COUNTERTOP HOLE

for unit to drop into.
Consider best placement for ease of use.
6" of clearance needed below countertop.
Ensure cord can reach power source.

EXISTING HOLE

Unit fits within countertop hole cutout diameters 5.5"–6.5"

TIP: Unit is factory assembled to fit 6" diameter hole. Skip steps 2 & 3 if countertop hole is 6" wide.

NEW HOLE

Use appropriate personnel and tools to cut a 6" diameter hole.

See below and refer to cutout template for details on an additional optional anti-rotational hole.

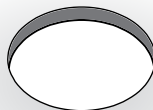

OPTIONAL

ADD ANTI-ROTATIONAL FOOT
to prevent unit pivoting within countertop hole.

- A** REMOVE OUTER SCREW from cord guard.
- B** INSERT ANTI-ROTATIONAL FOOT in place of removed screw.

C DRILL FOOT HOLE IN COUNTERTOP

Refer to cutout template for details.
Drill 3/4" diameter hole in countertop.

5.75"–6.5" diameter countertop holes:

Locate foot hole center 3.75" from large countertop hole center.

5.5" up to 5.75" diameter countertop hole:

Locate foot hole center 3.5" from large countertop hole center.

UNIT & ANTI-ROTATIONAL FOOT WILL FIT INTO CORRESPONDING COUNTERTOP HOLES.

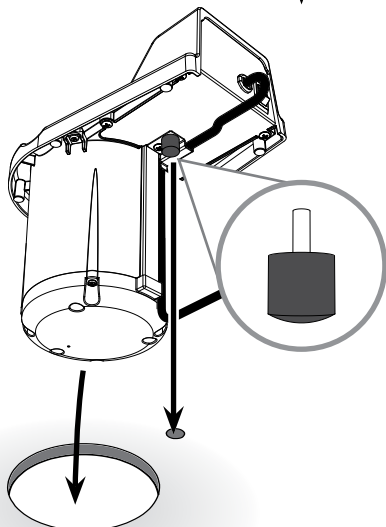
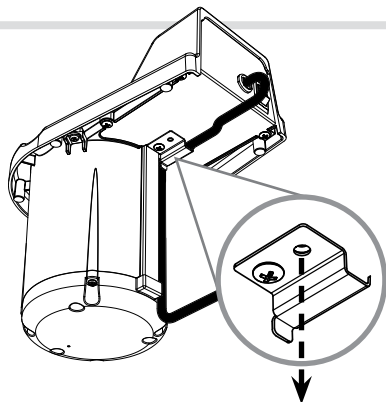

2 SELECT LOCATION BLOCK HARDWARE

to create proper fit within countertop hole.
 Hole diameter determines which 3 location blocks to use.
 If size is between two listed dimensions, refer to smaller diameter.

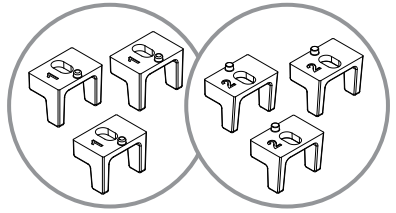

COUNTERTOP HOLE DIAMETER LOCATION BLOCKS

5.5"	No location blocks needed
5.75"	BLUE, embossed with "1"
6"	BLUE, embossed with "1"
6.25"	RED, embossed with "2"
6.5"	RED, embossed with "2"

3 ATTACH 3 LOCATION BLOCKS

to underside of rim.
 Place each location block peg into slot in underside of rim.

Slide location blocks either away from or towards base.
 Refer to chart below.

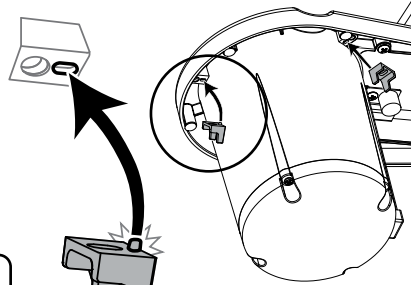

COUNTERTOP HOLE DIAMETER LOCATION BLOCK FITTING

5.5"	Remove all location blocks
5.75"	BLUE, slide towards base
6"	BLUE, slide away from base
6.25"	RED, slide towards base
6.5"	RED, slide away from base

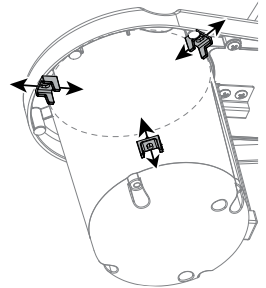

Screw in each location block using 1 screw and Phillips-head screwdriver.

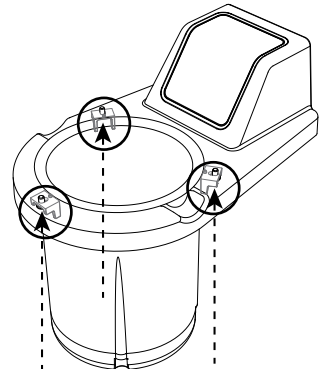

4

INSERT UNIT
and cord into countertop hole.

Refer to **CORD GUARD**
instructions below.
Secure excess cord to prevent
accidental damage.

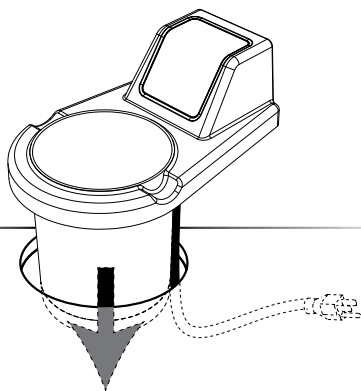

CORD GUARD



CAUTION-
PREVENT CORD DAMAGE
Secure cord within cord guard
when plug is used below counter.

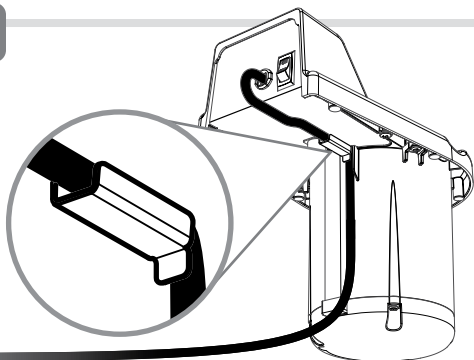

**USE CORD GUARD WHEN CORD IS
PLUGGED IN BELOW COUNTERTOP**

Affix cord guard using 2 screws
and Phillips-head screwdriver.

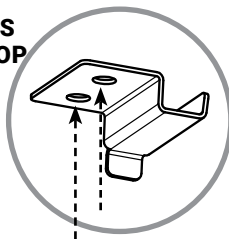

**DO NOT USE CORD GUARD
WHEN CORD IS PLUGGED IN
ABOVE COUNTERTOP**

A

DETACH CORD GUARD

Use Phillips-head screwdriver to remove both
screws.

B

RELEASE CORD

C

REATTACH CORD GUARD

with both screws.

Secure onto unit in case of future need.

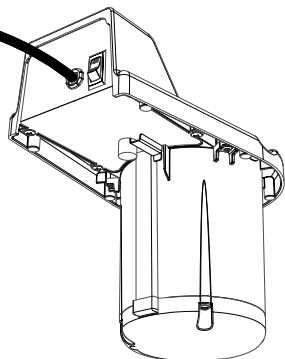

5 INSERT WATER PAN

- Insert green pan liner into bottom of pan.
- Fill 28 oz. of HOT water up to fill-line in pan.
Refer to water temperature charts below.
- Insert pan of water into basin.

Pour water into pan only.

DO NOT OVERFILL

Water above fill-line in pan may cause unsafe handling temperatures.

BE AWARE OF THE WATER TEMPERATURE

Help prevent bacteria growth. The FDA warns that bacteria grow most rapidly in the range of temperatures between 40°F–140°F. (4°C–60°C.)

WATER HEATING TIMES (When unit is *not* pre-heated)

INITIAL WATER TEMP.	TARGET TEMPERATURE	
	140°F	145°F
70°F	45 min.	50 min.
110°F	30 min.	40 min.
120°F	20 min.	30 min.
130°F	20 min.	25 min.

WATER HEATING TIMES (In pre-heated unit)

INITIAL WATER TEMP.	TARGET TEMPERATURE	
	140°F	145°F
70°F	35 min.	40 min.
110°F	20 min.	25 min.
120°F	10 min.	15 min.
130°F	5 min.	10 min.

YES →
Proper water level in PAN

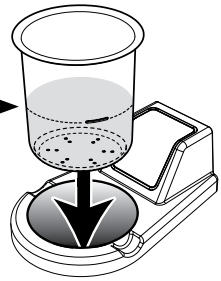

NO
Never pour water directly into BASIN



6 PLUG CORD INTO POWER SOURCE

7 TURN UNIT ON

Press switch at back of unit.

8 PRESS RESET TO START

countdown cycle.

Timer is programmed for 4 hour cycles.

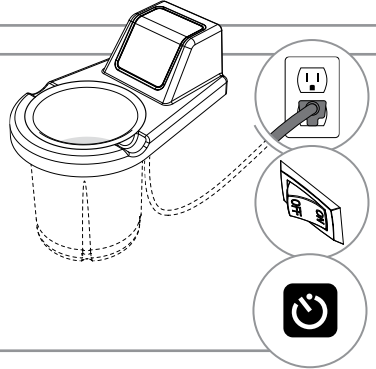

ONLY USE WITH UTENSILS SAFE IN HIGH TEMPERATURES



CAUTION- BURNS MAY RESULT

Do not use liquid or gel-filled utensils.
Handles become extremely hot.

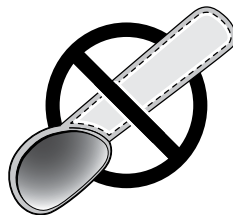

WATER CHANGE-OUT

1 REMOVE & EMPTY PAN OF WATER



CAUTION- HOT
Unit, pan and water will be hot.

Take proper care while removing pan.
Carefully pour water down a drain.
Keep the pan liner inside pan.

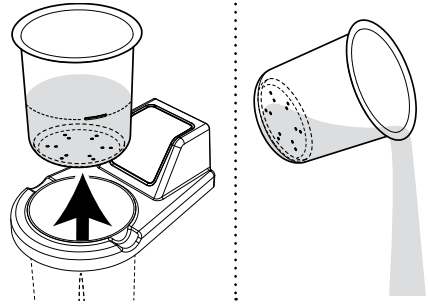

2 REFILL & RETURN WATER PAN TO BASIN

Fill 28 oz. of new **HOT** water up to
fill-line in pan.
Insert pan of water into basin.

**Never pour water
directly into basin of unit.
Pour water into pan only.**

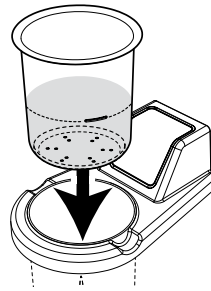

USING THE COUNTDOWN TIMER

Instructions for units with programmable timers.

1 PRESS RESET TO START COUNTDOWN CYCLE

Timer is factory programmed for 4 hour cycles.

When countdown timer ends:
Alarm will beep.
Display will indicate "END"



2 PRESS RESET TO STOP ALARM



3 CHANGE OUT WATER

Complete "WATER CHANGE-OUT" steps listed above.

4 PRESS RESET BUTTON

to restart the countdown cycle.



**To replace water *BEFORE* countdown
cycle ends,
follow steps 2–4.**

PROGRAMMING TIMER



Instructions for units with programmable timers.

SET COUNTDOWN CYCLE TIME

ENTER TIME PROGRAM MODE:

Simultaneously press and hold the **UP** and **RESET** buttons for 10 seconds.



Red light indicates unit is in timer program mode.

SELECT DESIRED COUNTDOWN TIME:

Press the **UP** or **DOWN** buttons.

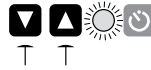

LOCK IN TIME SETTING AND EXIT PROGRAM MODE:

Press and hold the **RESET** button for 3 seconds.



SET ALARM VOLUME

ENTER ALARM PROGRAM MODE:

Simultaneously press and hold the **DOWN** and **RESET** buttons for 10 seconds.



Beeping indicates unit is in alarm program mode.

SELECT ALARM VOLUME:

Press the **UP** or **DOWN** buttons. A beep accompanies each level to indicate the volume setting. Volume level is shown in display. Adjust number to desired volume level.



VOLUME LEVELS

- 3- Highest volume
- 2- Average volume
- 1- Lowest volume
- 0- Silent (No audible alarm)

LOCK IN VOLUME SETTING AND EXIT PROGRAM MODE:

Press and hold the **RESET** button for 3 seconds.



UNIT TAKE-DOWN



CAUTION- HOT

Allow unit to cool first
or take proper care with hot surfaces.

- 1 PRESS SWITCH TO OFF
- 2 UNPLUG CORD
- 3 REMOVE PAN FROM BASIN
Pour water down a drain.
Clean pan and pan liner (See page 9.)

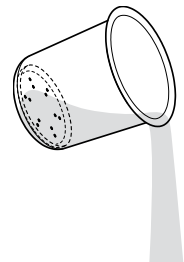
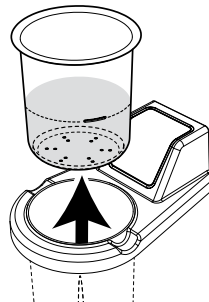

SAFETY



WARNING-
ELECTRICAL SHOCK COULD OCCUR

This unit must be earthed or grounded.

This requires all three prongs (terminals) on cord plug to be plugged into power source.

IMPORTANT TO KNOW

Certain ice cream scoops and spades contain heat-conductive fluid inside handles.



CAUTION-
BURNS MAY RESULT

Do not use liquid or gel-filled utensils. Handles become extremely hot.

Only use ConserveWell™ with utensils safe at high temperatures.

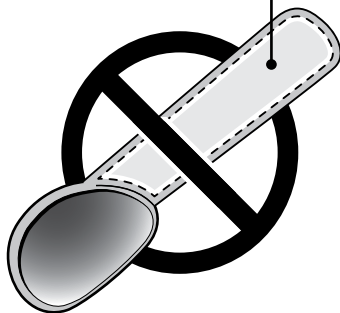

BE AWARE OF THE WATER TEMPERATURE

Help prevent bacteria growth. The FDA warns that bacteria grow most rapidly in the range of temperatures between 40°F–140°F. (4°C–60°C.)



NSF International listed.
This unit is not to be used for serving food.



UL US LISTED

CLEANING



WARNING- **ELECTRICAL SHOCK COULD OCCUR**

- Electrical components of unit could be damaged from water exposure or any liquid.
- Never immerse unit into water or any liquid.
- Never use any water jet or pressure sprayer on unit.
- Ensure unit is "OFF" and unplugged.



CAUTION- HOT **Allow unit to cool before cleaning.**

YES!

Use dishwashing soap and hot water



Pan & Pan Liner are dishwasher safe.

CLEAN THE PAN & PAN LINER

- 1 CLEAN**
Wash water pan and pan liner with soap and hot water.
- 2 RINSE**
fully with clear water.
- 3 SANITIZE**
all parts according to local sanitization requirements. All parts in contact with food must be sanitized.
- 4 DRY**
pan fully with a clean soft cloth.
Air dry pan liner fully.

CLEAN EXTERNAL SURFACES

- Wipe daily with a clean damp cloth.
- Dry with a clean soft cloth.
- Glass and surface cleaners approved for use in food contact areas may be used.

CARE OF STAINLESS STEEL

The water pan is constructed of stainless steel.

If you notice corrosion beginning on any stainless steel surface, you may need to change the cleansing agent, sanitizing agent, or the cleaning procedures you are using.

- A mildly abrasive nylon or brass brush may be used to remove any stubborn deposits on interior surfaces of unit.
- Fully rinsing and drying all parts can help prevent corrosion. Elements and minerals in tap water can accumulate on stainless steel parts and create corrosion.
- Do not use abrasive, caustic or ammonia based cleansers.
- Do not use products containing acids, alkalines, chlorine, or salt. These agents can corrode stainless steel.
- Do not use metal scrapers or cleaning pads that could scratch surfaces.

WIRING DIAGRAM

87760

120V USA

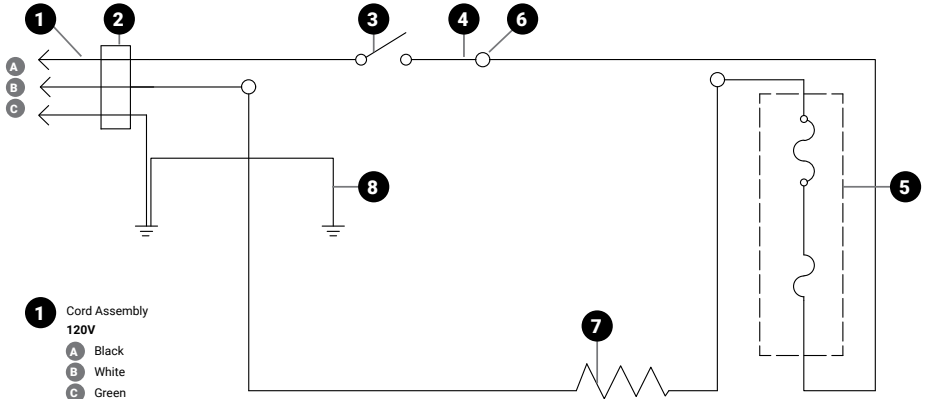

- 1** Cord Assembly
120V
A Black
B White
C Green

- 2** Bushing/Strain Relief

- 3** Rocker Switch

- 4** Wire Assembly, 18GA, Black, 4"

- 5** Thermal Assembly, Cut-out

- 6** Wire Nut

- 7** 100W Silicone Element

- 8** Wire Assembly, 18GA, Green, 14"

87770

120V USA

Programmable Timer

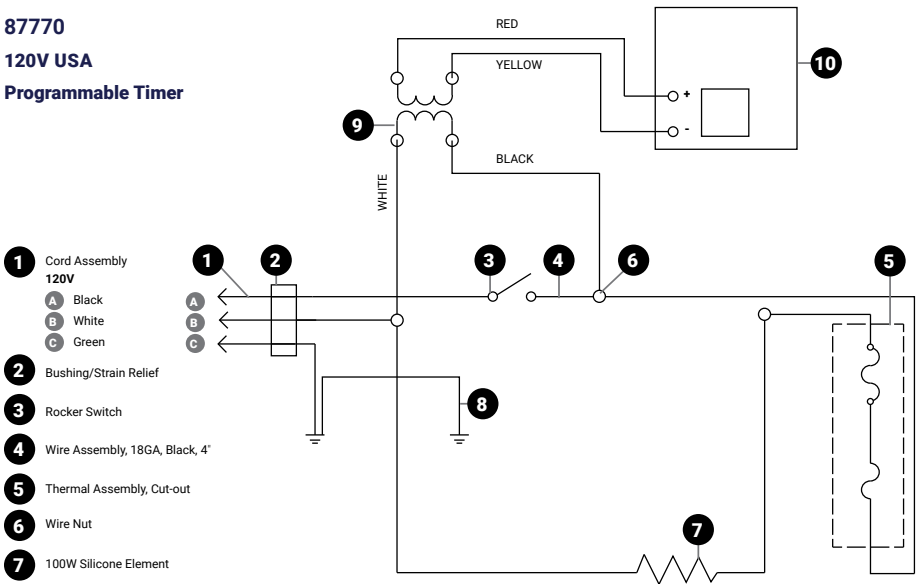

- 1** Cord Assembly
120V
A Black
B White
C Green

- 2** Bushing/Strain Relief

- 3** Rocker Switch

- 4** Wire Assembly, 18GA, Black, 4"

- 5** Thermal Assembly, Cut-out

- 6** Wire Nut

- 7** 100W Silicone Element

- 8** Wire Assembly, 18GA, Green, 14"

- 9** Transformer Assembly

- 10** Timer Board

TROUBLESHOOTING

UNIT DOES NOT HEAT?

- Ensure cord is securely plugged in.
- Ensure power is available from source.
- Ensure unit is on.

UNIT OVERHEATING?

- Ensure water has not spilled or leaked from pan into the basin.

CAUTION:

WATER IN BASIN MAY STEAM & BURN.

- Allow unit to cool. Pour out any water and dry basin.

UTENSILS OR TOP OF PAN GETTING TOO HOT?

- *Do not use liquid or gel-filled utensils.*

Handles become extremely hot. Only use utensils safe at high temperatures.

- Limit water volume to the fill-line. (Do not exceed 28 oz. of water.)

DO NOT OVERFILL

Water above fill-line in pan may cause unsafe handling temperatures.

Overfilling pan with water may conduct excessive heat to utensil handles or top of pan.

WATER NOT REACHING 140° F?

- Make sure to use HOT water in pan. Refer to temperature charts on page 5.
- Damaged pan may not heat properly. Inspect and replace pan if needed. Use pan liner to protect pan bottom from damage.



SERVER PRODUCTS LIMITED WARRANTY

2 YEAR
WARRANTY

This Server product is backed by a two-year limited warranty against defects in materials and workmanship. See Server-Products.com for details.

GENERAL SERVICE, REPAIR OR RETURNS

Before sending any item to Server Products for service, repair, or return, contact Server Products customer service to request a **Return Authorization Number**. Merchandise must be sent to Server Products with this number. Service is extremely prompt. Typically, units are repaired and ship out within 48 hours of receipt.

Merchandise being returned for credit must be in new and unused condition and not more than 90 days old and will be subject to a 20% restocking charge. Electrical parts (thermostats, heating elements, etc.) are not returnable.

Servicing Cord: Specific tools are required for safe and proper power supply cord removal and installation. If cord must be replaced, only a representative of the OEM (original equipment manufacturer) or a qualified technician may replace cord. Cord must meet code designation H05 RN-F requirements.

CONSERVEWELL™ DROP-IN

MODEL: CW-DI

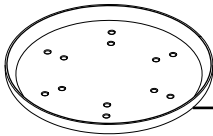

PAN LINER
87774

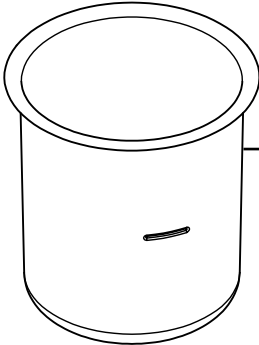

PAN
87771

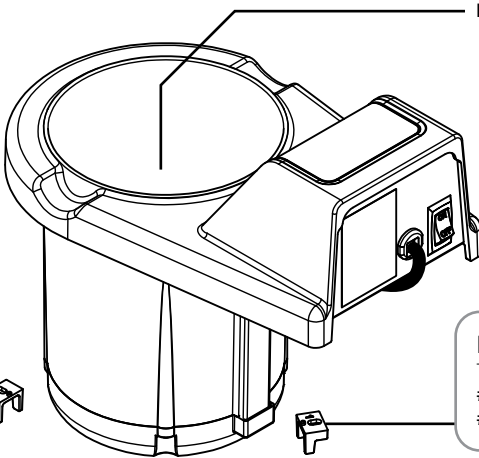

BASIN

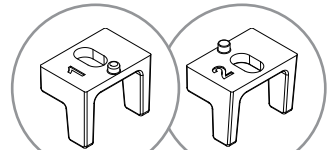

LOCATOR BLOCK HARDWARE

Two Sets Supplied:

#1 BLUE LOCATOR BLOCKS (QTY 3) 87785

#2 RED LOCATOR BLOCKS (QTY 3) 87786



CORD GUARD
87795



ANTI-ROTATIONAL FOOT
81058

NEED HELP?

Server Products Inc.

3601 Pleasant Hill Road
Richfield, WI 53076 USA

Chat with us!

spsales@server-products.com

262.628.5600 | 800.558.8722

Please be prepared with your **Model, P/N** and **Series** located on the lid or base of the unit.

Example:



COUNTERTOP CUTOUT TEMPLATE

READ MANUAL FOR COMPLETE INSTRUCTIONS

(FRONT OF UNIT)

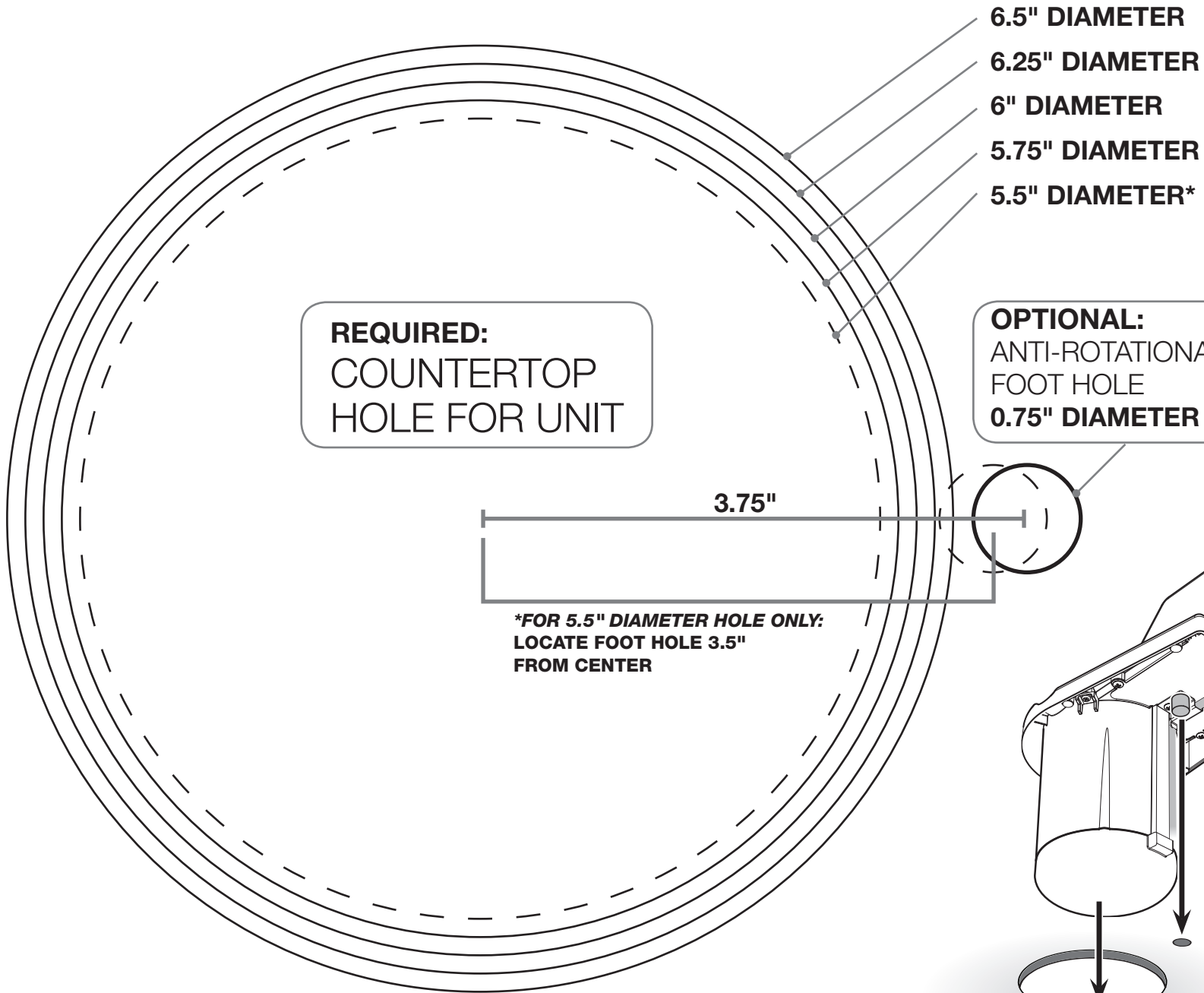

(BACK OF UNIT)

