

**WINDOW TYPE ROOM AIR CONDITIONER**

---

# User's Manual



EWM05B

EWR06BE

EWR08BE

EWR10BE

EWR12BE

EWR14B



**IMPORTANT NOTE:**

- Before using your air conditioner, please read this manual carefully and keep it for future reference.

# Table of Contents





<b>Important Safety Instructions .....</b>	<b>03</b>
<b>Installation Instructions.....</b>	<b>13</b>
<b>Normal Sounds.....</b>	<b>27</b>
<b>Air Conditioner Features.....</b>	<b>28</b>
<b>Care and Cleaning.....</b>	<b>33</b>
<b>Troubleshooting Tips.....</b>	<b>34</b>

# Important Safety Instructions

## READ THIS MANUAL

Inside you will find many helpful hints on how to use and maintain your air conditioner properly. Just a little preventive care on your part can save you a great deal of time and money over the life of your air conditioner. You'll find many answers to common problems in the chart of troubleshooting tips. If you review our chart of Troubleshooting Tips first, you may not need to call for service at all.

To prevent injury to the user or other people and property damage, the following instructions must be followed. Incorrect operation due to ignoring of instructions may cause harm or damage. The seriousness is classified by the following indications.

 <b>WARNING</b>	This symbol indicates the possibility of death or serious injury .		
 <b>CAUTION</b>	This symbol indicates the possibility of injury or damage to property.		
	<b>Never do this.</b>		<b>Always do this.</b>

## **WARNING**

- Plug in power plug properly. Otherwise, it may cause electric shock or fire due to excess heat generation. Do not operate or stop the unit by inserting or pulling out the power plug. It may cause electric shock or fire due to heat generation. Do not damage or use an unspecified power cord. It may cause electric shock or fire. If the power cord is damaged, it must be replaced by the manufacturer or an authorised service centre or a similarly qualified person in order to avoid a hazard.
- Always install circuit breaker and a dedicated power circuit. Incorrect installation may cause fire and electric shock. Do not operate with wet hands or in damp environment. It may cause electric shock . Do not direct airflow at room occupants only. This could damage your health.
- Always ensure effective grounding. Incorrect grounding may cause electric shock. Do not allow water to run into electric parts. It may cause failure of machine or electric shock. Do not modify power cord length or share the outlet with other appliances. It may cause electric shock or fire due to heat generation.
- Unplug the unit if strange sounds, smell, or smoke comes from it. It may cause fire and electric shock. Do not use the socket if it is loose or damaged. It may cause fire and electric shock. Do not open the unit during operation. It may cause electric shock.
- Keep firearms away. It may cause fire. Do not use the power cord close to heating appliances. It may cause fire and electric shock. Do not use the power cord near flammable gas or combustibles, such as gasoline, benzene, thinner, etc. It may cause an explosion or fire.
- Ventilate room before operating air conditioner if there is a gas leakage from another appliance. It may cause explosion, fire and, burns. Do not disassemble or modify unit. It may cause failure and electric shock.

**⚠ CAUTION**

- When the air filter is to be removed, do not touch the metal parts of the unit. It may cause an injury. Do not put a pet or house plant where it will be exposed to direct air flow. This could injure the pet or plant. Ventilate the room well when used together with a stove, etc. An oxygen shortage may occur.
- Do not use strong detergent such as wax or thinner but use a soft cloth. Appearance may be deteriorated due to change of product color or scratching of its surface. Do not clean the air conditioner with water. Water may enter the unit and degrade the insulation. It may cause an electric shock. Do not use for special purposes. Do not use this air conditioner to preserve precision devices, food, pets, plants, and art objects. It may cause deterioration of quality, etc.
- Stop operation and close the window in storm or hurricane. Operation with windows opened may cause wetting of indoor and soaking of household furniture. When the unit is to be cleaned, switch off, and turn off the circuit breaker. Do not clean unit when power is on as it may cause fire and electric shock, it may cause an injury. Ensure that the installation bracket of the outdoor appliance is not damaged due to prolonged exposure.
- If bracket is damaged, there is concern of damage due to falling of unit. Always insert the filters securely. Clean filter once every two weeks. Operation without filters may cause failure. Hold the plug by the head of the power plug when taking it out. It may cause electric shock and damage. Turn off the main power switch when not using the unit for a long time. It may cause failure of product or fire.
- Do not place obstacles around air-inlets or inside of air-outlet. It may cause failure of appliance or accident. Do not place heavy object on the power cord and ensure that the cord is not compressed. There is danger of fire or electric shock. Do not drink water drained from air conditioner. It contains contaminants and could make you sick.
- Use caution when unpacking and installing. Sharp edges could cause injury.
- If water enters the unit, turn the unit off at the power outlet and switch off the circuit breaker. Isolate supply by taking the power-plug out and contact a qualified service technician.

**⚠ CAUTION**

- This appliance is not intended for use by persons (including children) with reduced physical, sensory or mental capabilities or lack of experience and knowledge, unless they have been given supervision or instruction concerning use of the appliance by a person responsible for their safety.
- Children should be supervised to ensure that they do not play with the appliance.
- If the supply cord is damaged, it must be replaced by the manufacturer, its service agent or similarly qualified persons in order to avoid a hazard.
- The appliance shall be installed in accordance with national wiring regulations.
- Do not operate your air conditioner in a wet room such as a bathroom or laundry room.
- The appliance with electric heater shall have at least 1 meter space to the combustible materials.
- Contact the authorised service technician for repair or maintenance of this unit.
- Contact the authorised installer for installation of this unit.
- Do not operate the louvers with your hands, it may cause an injury.

**NOTE:**

The power supply cord with this air conditioner contains a current detection device designed to reduce the risk of fire. Please refer to the section Operation of Current Device for details. In the event that the power supply cord is damaged, it cannot be repaired—it must be replaced with a cord from the Product Manufacturer.

**WARNING**

Avoid fire hazard or electric shock. Do not use an extension cord or an adaptor plug. Do not remove any prong from the power cord.

Grounding type wall receptacle

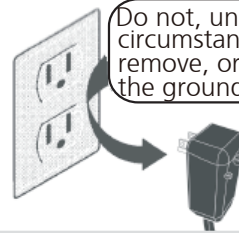

Power supply cord with 3-prong grounding plug and current detection device.

**WARNING****For Your Safety**

Do not store or use gasoline or other flammable vapors and liquids in the vicinity of this or any other appliance.

**Prevent Accidents**

To reduce the risk of fire, electrical shock, or injury to persons when using your air conditioner, follow basic precautions, including the following:

- Be sure the electrical service is adequate for the model you have chosen. This information can be found on the serial plate, which is located on the side of the cabinet and behind the grille.
- If the air conditioner is to be installed in a window, you will probably want to clean both sides of the glass first. If the window is a triple-track type it has a screen panel included, remove the screen completely before installation.
- Be sure the air conditioner has been secured and correctly installed according to the installation instructions in this manual. Save this manual for possible future use in removing or installing this unit. When handling the air conditioner, be careful to avoid cuts from sharp metal fins on front and rear coils.

**Electrical Information**

The complete electrical rating of your new room air conditioner is stated on the serial plate. Refer to the rating when checking the electrical requirements.

- Be sure the air conditioner is properly grounded. To minimize shock and fire hazards, proper grounding is important. The power cord is equipped with a three-prong grounding plug for protection against shock hazards.
- Your air conditioner must be used in a properly grounded wall receptacle. If the wall receptacle you intend to use is not adequately grounded or protected by a time delay fuse or circuit breaker, have a qualified electrician install the proper receptacle. Ensure the receptacle is accessible after the unit installation.
- Do not run air conditioner without side protective cover in place. This could result in mechanical damage within the air conditioner.
- Do not use an extension cord or an adapter plug.

## Operation of Current Device (Applicable to the unit adopts current detection device only )

The power supply cord contains a current device that senses damage to the power cord. To test your power supply cord do the following:

1. Plug in the Air Conditioner.
2. The power supply cord will have TWO buttons on the plug head. Press the TEST button, you will notice a click as the RESET button pops out.
3. Press the RESET button, again you will notice a click as the button engages.
4. The power supply cord is now supplying electricity to the unit. (On some products this it also indicated by a light on the plug head.)



### NOTE:

- Do not use this device to turn the unit on or off.
- Always make sure the RESET button is pushed in for correct operation.
- The power supply must be replaced if it fails reset when either the TEST button is pushed, or it cannot be reset. A new one can be obtained from the product manufacturer.
- If power supply cord is damaged, it cannot be repaired. It MUST be replaced by one obtained from the product manufacturer.

NOTE: This air conditioner is designed to be operated under condition as follows:

Cooling operation	Outdoor temp:	64-109°F/18-43°C (64-125°F/18-52°C for special tropical models)
	Indoor temp:	62-90°F/17-32°C
Heating operation	Outdoor temp:	23-76°F/-5-24°C
	Indoor temp:	32-80°F/0-27°C

**Note: Performance may be reduced outside of these operating temperatures.**

### WARNING: (for using R290/R32 refrigerant only)

- Do not use means to accelerate the defrosting process or to clean, other than those recommended by the manufacturer.
- The appliance shall be stored in a room without continuously operating ignition sources (for example: open flames, an operating gas appliance) and ignition sources (for example: an operating electric heater) close to the appliance. The appliance shall be stored in a room without continuously operating ignition sources (for example: open flames, an operating gas appliance or an operating electric heater).
- Do not pierce or burn.
- Be aware that the refrigerants may not contain an odour.
- Compliance with national gas regulations shall be observed.
- Keep ventilation openings clear of obstruction.
- The appliance shall be stored so as to prevent mechanical damage from occurring.
- A warning that the appliance shall be stored in a well-ventilated area where the room size corresponds to the room area as specified for operation.
- Any person who is involved with working on or breaking into a refrigerant circuit should hold a current valid certificate from an industry-accredited assessment authority, which authorises their competence to handle refrigerants safely in accordance with an industry recognised assessment specification.

- Servicing shall only be performed as recommended by the equipment manufacturer. Maintenance and repair requiring the assistance of other skilled personnel shall be carried out under the supervision of the person competent in the use of flammable refrigerants.
- DO NOT modify the length of the power cord or use an extension cord to power the unit. DO NOT share a single outlet with other electrical appliances. Improper power supply can cause fire or electrical shock.
- Please follow the instruction carefully to handle, install, clear, service the air conditioner to avoid any damage or hazard. Flammable Refrigerant R32 is used within air conditioner. When maintaining or disposing the air conditioner, the refrigerant (R32 or R290) shall be recovered properly, shall not discharge to air directly.
- No any open fire or device like switch which may generate spark/arcing shall be around air conditioner to avoid causing ignition of the flammable refrigerant used. Please follow the instruction carefully to store or maintain the air conditioner to prevent mechanical damage from occurring.
- Flammable refrigerant -R32 is used in air conditioner. Please follow the instruction carefully to avoid any hazard.

**AVERTISSEMENT**

Ne pas utiliser de produits permettant d accélérer le dégel ou de produits de nettoyage autres que ceux recommandés par le fabricant.  
 L'appareil doit être entreposé dans un endroit sans source d allumage fonctionnant en continu (par exemple : flamme nue, appareil au gaz en marche ou radiateur électrique en marche).  
 Ne pas percer ni brûler.  
 Attention : les frigorigènes peuvent être inodores.





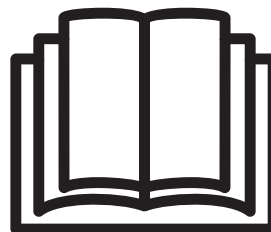

Caution: Risk of fire/  
 flammable materials  
 (Required for R32/R290 units only)



**IMPORTANT NOTE:**Read this manual carefully before installing or operating your new air conditioning unit. Make sure to save this manual for future reference.

**Explanation of symbols displayed on the unit(For the unit adopts R32/R290 Refrigerant only):**

	<b>WARNING</b>	This symbol shows that this appliance used a flammable refrigerant. If the refrigerant is leaked and exposed to an external ignition source, there is a risk of fire.
	<b>CAUTION</b>	This symbol shows that the operation manual should be read carefully.
	<b>CAUTION</b>	This symbol shows that a service personnel should be handling this equipment with reference to the installation manual.
	<b>CAUTION</b>	This symbol shows that information is available such as the operating manual or installation manual.

**⚠ WARNINGS (for using R290/R32 refrigerant only)****1. Transport of equipment containing flammable refrigerants**

See transport regulations

**2. Marking of equipment using signs**

See local regulations

**3. Disposal of equipment using flammable refrigerants**

See national regulations.

**4. Storage of equipment/appliances**

The storage of equipment should be in accordance with the manufacturer's instructions.

**5. Storage of packed (unsold) equipment**

Storage package protection should be constructed such that mechanical damage to the equipment inside the package will not cause a leak of the refrigerant charge.

The maximum number of pieces of equipment permitted to be stored together will be determined by local regulations.

**6. Information on servicing****1) Checks to the area**

Prior to beginning work on systems containing flammable refrigerants, safety checks are necessary to ensure that the risk of ignition is minimised. For repair to the refrigerating system, the following precautions shall be complied with prior to conducting work on the system.

**2) Work procedure**

Work shall be undertaken under a controlled procedure so as to minimise the risk of a flammable gas or vapour being present while the work is being performed.

**3) General work area**

All maintenance staff and others working in the local area shall be instructed on the nature of work being carried out. Work in confined spaces shall be avoided. The area around the workspace shall be sectioned off. Ensure that the conditions within the area have been made safe by control of flammable material.

**4) Checking for presence of refrigerant**

The area shall be checked with an appropriate refrigerant detector prior to and during work, to ensure the technician is aware of potentially flammable atmospheres. Ensure that the leak detection equipment being used is suitable for use with flammable refrigerants, i.e. non-sparking, adequately sealed or intrinsically safe.

**5) Presence of fire extinguisher**

If any hot work is to be conducted on the refrigeration equipment or any associated parts, appropriate fire extinguishing equipment shall be available to hand. Have a dry powder or CO<sub>2</sub> fire extinguisher adjacent to the charging area.

**6) No ignition sources**

No person carrying out work in relation to a refrigeration system which involves exposing any pipe work that contains or has contained flammable refrigerant shall use any sources of ignition in such a manner that it may lead to the risk of fire or explosion. All possible ignition sources, including cigarette smoking, should be kept sufficiently far away from the site of installation, repairing, removing and disposal, during which flammable refrigerant can possibly be released to the surrounding space. Prior to work taking place, the area around the equipment is to be surveyed to make sure that there are no flammable hazards or ignition risks. No Smoking signs shall be displayed.

## **WARNINGS (for using R290/R32 refrigerant only)**

### 7)ventilated area

Ensure that the area is in the open or that it is adequately ventilated before breaking into the system or conducting any hot work. A degree of ventilation shall continue during the period that the work is carried out. The ventilation should safely disperse any released refrigerant and preferably expel it externally into the atmosphere.

### 8)Checks to the refrigeration equipment

Where electrical components are being changed, they shall be fit for the purpose and to the correct specification. At all times the manufacturer's maintenance and service guidelines shall be followed. If in doubt consult the manufacturer's technical department for assistance. The following checks shall be applied to installations using flammable refrigerants:

The charge size is in accordance with the room size within which the refrigerant containing parts are installed;

The ventilation machinery and outlets are operating adequately and are not obstructed;

If an indirect refrigerating circuit is being used, the secondary circuit shall be checked for the presence of refrigerant;

Marking to the equipment continues to be visible and legible. Markings and signs that are illegible shall be corrected;

Refrigeration pipe or components are installed in a position where they are unlikely to be exposed to any substance which may corrode refrigerant containing components, unless the components are constructed of materials which are inherently resistant to being corroded or are suitably protected against being so corroded.

### 9)Checks to electrical devices

Repair and maintenance to electrical components shall include initial safety checks and component inspection procedures. If a fault exists that could compromise safety, then no electrical supply shall be connected to the circuit until it is satisfactorily dealt with. If the fault cannot be corrected immediately but it is necessary to continue operation, an adequate temporary solution shall be used. This shall be reported to the owner of the equipment so all parties are advised.

Initial safety checks shall include:

That capacitors are discharged: this shall be done in a safe manner to avoid possibility of sparking;

That there no live electrical components and wiring are exposed while charging, recovering or purging the system;

That there is continuity of earth bonding.

## **7.Repairs to sealed components**

1)During repairs to sealed components, all electrical supplies shall be disconnected from the equipment being worked upon prior to any removal of sealed covers, etc. If it is absolutely necessary to have an electrical supply to equipment during servicing, then a permanently operating form of leak detection shall be located at the most critical point to warn of a potentially hazardous situation.

2)Particular attention shall be paid to the following to ensure that by working on electrical components, the casing is not altered in such a way that the level of protection is affected. This shall include damage to cables, excessive number of connections, terminals not made to original specification, damage to seals, incorrect fitting of glands, etc.

Ensure that apparatus is mounted securely.

**⚠ WARNINGS (for using R290/R32 refrigerant only)**

Ensure that seals or sealing materials have not degraded such that they no longer serve the purpose of preventing the ingress of flammable atmospheres. Replacement parts shall be in accordance with the manufacturer's specifications.

NOTE: The use of silicon sealant may inhibit the effectiveness of some types of leak detection equipment. Intrinsically safe components do not have to be isolated prior to working on them.

**8.Repair to intrinsically safe components**

Do not apply any permanent inductive or capacitance loads to the circuit without ensuring that this will not exceed the permissible voltage and current permitted for the equipment in use. Intrinsically safe components are the only types that can be worked on while live in the presence of a flammable atmosphere. The test apparatus shall be at the correct rating. Replace components only with parts specified by the manufacturer. Other parts may result in the ignition of refrigerant in the atmosphere from a leak.

**9.Cabling**

Check that cabling will not be subject to wear, corrosion, excessive pressure, vibration, sharp edges or any other adverse environmental effects. The check shall also take into account the effects of aging or continual vibration from sources such as compressors or fans.

**10.Detection of flammable refrigerants**

Under no circumstances shall potential sources of ignition be used in the searching for or detection of refrigerant leaks. A halide torch (or any other detector using a naked flame) shall not be used.

**11.Leak detection methods**

The following leak detection methods are deemed acceptable for systems containing flammable refrigerants. Electronic leak detectors shall be used to detect flammable refrigerants, but the sensitivity may not be adequate, or may need re-calibration. (Detection equipment shall be calibrated in a refrigerant-free area.) Ensure that the detector is not a potential source of ignition and is suitable for the refrigerant used. Leak detection equipment shall be set at a percentage of the LFL of the refrigerant and shall be calibrated to the refrigerant employed and the appropriate percentage of gas (25 % maximum) is confirmed. Leak detection fluids are suitable for use with most refrigerants but the use of detergents containing chlorine shall be avoided as the chlorine may react with the refrigerant and corrode the copper pipe-work. If a leak is suspected, all naked flames shall be removed/ extinguished. If a leakage of refrigerant is found which requires brazing, all of the refrigerant shall be recovered from the system, or isolated (by means of shut off valves) in a part of the system remote from the leak. Oxygen free nitrogen (OFN) shall then be purged through the system both before and during the brazing process.

**12.Removal and evacuation**

When breaking into the refrigerant circuit to make repairs or for any other purpose conventional procedures shall be used. However, it is important that best practice is followed since flammability is a consideration. Opening of the refrigeration systems shall not be done by brazing. The following procedure shall be adhered to:

- Remove refrigerant;
- Purge the circuit with inert gas;
- Evacuate;
- Purge again with inert gas;

**⚠ WARNINGS (for using R290/R32 refrigerant only)**

Open the circuit by cutting or brazing.

The refrigerant charge shall be recovered into the correct recovery cylinders. The system shall be flushed with OFN to render the unit safe. This process may need to be repeated several times. Compressed air or oxygen shall not be used for this task.

Flushing shall be achieved by breaking the vacuum in the system with OFN and continuing to fill until the working pressure is achieved, then venting to atmosphere, and finally pulling down to a vacuum. This process shall be repeated until no refrigerant is within the system. When the final OFN charge is used, the system shall be vented down to atmospheric pressure to enable work to take place. This operation is absolutely vital if brazing operations on the pipe-work are to take place.

Ensure that the outlet for the vacuum pump is not close to any ignition sources and there is ventilation available.

**13.Charging procedures**

In addition to conventional charging procedures, the following requirements shall be followed. Ensure that contamination of different refrigerants does not occur when using charging equipment. Hoses or lines shall be as short as possible to minimise the amount of refrigerant contained in them.

Cylinders shall be kept upright.

Ensure that the refrigeration system is earthed prior to charging the system with refrigerant. Label the system when charging is complete (if not already).

Extreme care shall be taken not to overfill the refrigeration system.

Prior to recharging the system it shall be pressure tested with OFN. The system shall be leak tested on completion of charging but prior to commissioning. A follow up leak test shall be carried out prior to leaving the site.

**14.Decommissioning**

Before carrying out this procedure, it is essential that the technician is completely familiar with the equipment and all its detail. It is recommended good practice that all refrigerants are recovered safely. Prior to the task being carried out, an oil and refrigerant sample shall be taken in case analysis is required prior to re-use of reclaimed refrigerant. It is essential that electrical power is available before the task is commenced.

a) Become familiar with the equipment and its operation.

b) Isolate system electrically.

c) Before attempting the procedure ensure that:

Mechanical handling equipment is available, if required, for handling refrigerant cylinders;

All personal protective equipment is available and being used correctly;

The recovery process is supervised at all times by a competent person;

Recovery equipment and cylinders conform to the appropriate standards.

d) Pump down refrigerant system, if possible.

e) If a vacuum is not possible, make a manifold so that refrigerant can be removed from various parts of the system.

f) Make sure that cylinder is situated on the scales before recovery takes place.

g) Start the recovery machine and operate in accordance with manufacturer's instructions.

h) Do not overfill cylinders. (No more than 80 % volume liquid charge).

i) Do not exceed the maximum working pressure of the cylinder, even temporarily.

**⚠ WARNINGS (for using R290/R32 refrigerant only)**

j)When the cylinders have been filled correctly and the process completed, make sure that the cylinders and the equipment are removed from site promptly and all isolation valves on the equipment are closed off.

k)Recovered refrigerant shall not be charged into another refrigeration system unless it has been cleaned and checked.

**15.Labelling**

Equipment shall be labelled stating that it has been de-commissioned and emptied of refrigerant. The label shall be dated and signed. Ensure that there are labels on the equipment stating the equipment contains flammable refrigerant.

**16.Recovery**

When removing refrigerant from a system, either for servicing or decommissioning, it is recommended good practice that all refrigerants are removed safely.

When transferring refrigerant into cylinders, ensure that only appropriate refrigerant recovery cylinders are employed. Ensure that the correct number of cylinders for holding the total system charge is available. All cylinders to be used are designated for the recovered refrigerant and labelled for that refrigerant (i.e. special cylinders for the recovery of refrigerant). Cylinders shall be complete with pressure relief valve and associated shut-off valves in good working order. Empty recovery cylinders are evacuated and, if possible, cooled before recovery occurs.

The recovery equipment shall be in good working order with a set of instructions concerning the equipment that is at hand and shall be suitable for the recovery of flammable refrigerants. In addition, a set of calibrated weighing scales shall be available and in good working order. Hoses shall be complete with leak-free disconnect couplings and in good condition. Before using the recovery machine, check that it is in satisfactory working order, has been properly maintained and that any associated electrical components are sealed to prevent ignition in the event of a refrigerant release. Consult manufacturer if in doubt.

The recovered refrigerant shall be returned to the refrigerant supplier in the correct recovery cylinder, and the relevant Waste Transfer Note arranged. Do not mix refrigerants in recovery units and especially not in cylinders. If compressors or compressor oils are to be removed, ensure that they have been evacuated to an acceptable level to make certain that flammable refrigerant does not remain within the lubricant. The evacuation process shall be carried out prior to returning the compressor to the suppliers. Only electric heating to the compressor body shall be employed to accelerate this process. When oil is drained from a system, it shall be carried out safely.

# Installation Instructions

**NOTE:** The unit you purchased may be look like one of the followings:

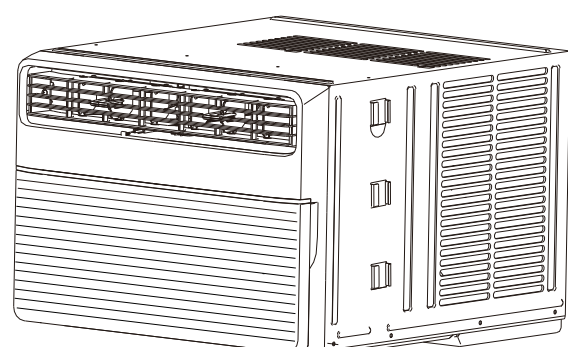
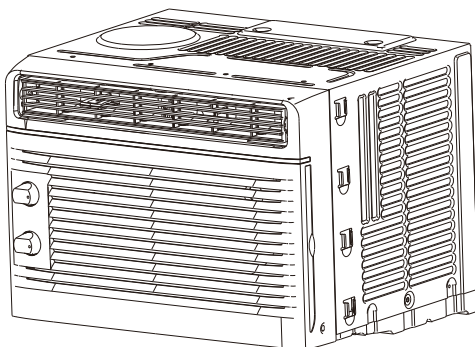
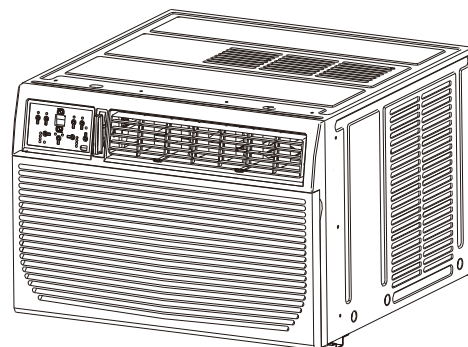
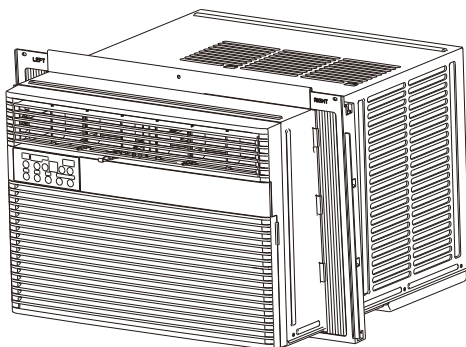
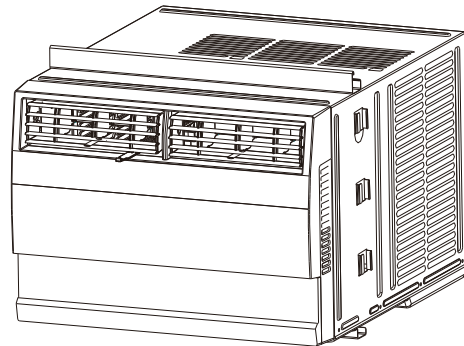
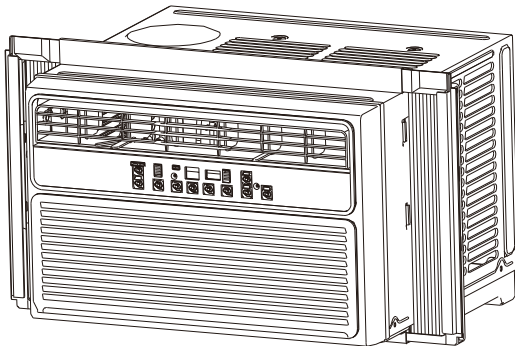
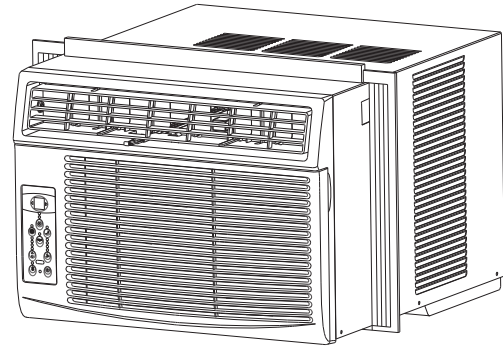
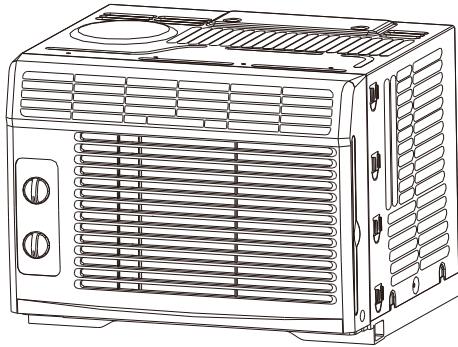

 **NOTE:**

All the illustrations in this manual are for explanation purpose only. The air conditioner you have may be slightly different. The actual shape shall prevail.

## Installation Instructions (for 5000 to 14500Btu/h)



### BEFORE YOU BEGIN

Read these instructions completely and carefully.  
**IMPORTANT**-Save these instructions for local inspector's use.  
**IMPORTANT**-Observe all governing codes and ordinances.  
 Note to Installer- Be sure to leave these instructions with the Consumer.  
 Note to Consumer- Keep these instructions for future reference.  
 Skill level- Installation of this appliance requires basic mechanical skills.  
 Completion time- Approximately 1 hour.  
 We recommend that two people install this product.  
 Proper installation is the responsibility of the installer.  
 Product failure due to improper installation is not covered under the Warranty.  
 You **MUST** use all supplied parts and use proper installation procedures as described in these instructions when installing this air conditioner.

### ! WINDOW REQUIREMENTS

Your air conditioner is designed to install in standard double hung windows with opening widths of 23 to 36 inches (584mm to 914mm).

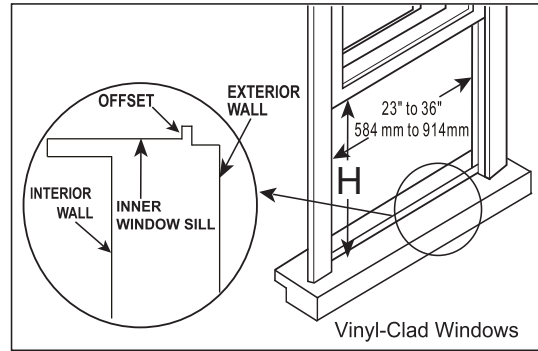
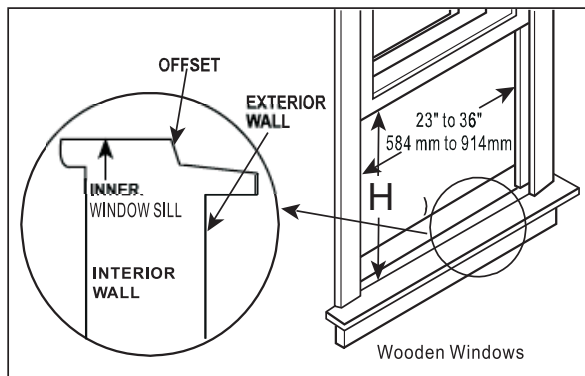

Model	5000~6000Btu/h	6000~8000Btu/h	10000~14500Btu/h
H	13"(330mm)	14"(356mm)	15-1/2"(394mm)

Table 1

### ! CAUTION

Do not, under any circumstances, cut or remove the third (ground) prong from the power cord.  
 Do not change the plug on the power cord of the air conditioner.  
 Aluminum house wiring may present special problems- consult a qualified electrician. When handling unit, be careful to avoid cuts from sharp metal edges and aluminum fins on front and rear coils.

### TOOLS YOU WILL NEED



Screwdriver



Level

### TOOLS YOU MAY USE

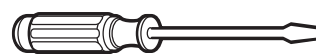

Screwdriver



Pencil

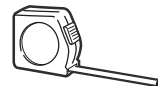

Ruler or tape measure



Scissors or knife

### ! NOTE:

Save Carton and these Installation Instructions for future reference. The carton is the best way to store unit during winter, or when not in use.

## 1 PREPARE THE WINDOW

Lower sash must open sufficiently to allow a clear vertical opening. The window opening height shall be based on the different Models:  
 13inches/330mm(5k~6k units), 14inches/356mm (6k~8k units), 15-1/2inches/394mm(10k~12k units).  
 Side louvers and the rear of the AC must have clear air space to allow enough airflow through the condenser, for heat removal. The rear of the unit must be outdoors, not inside a building or garage.

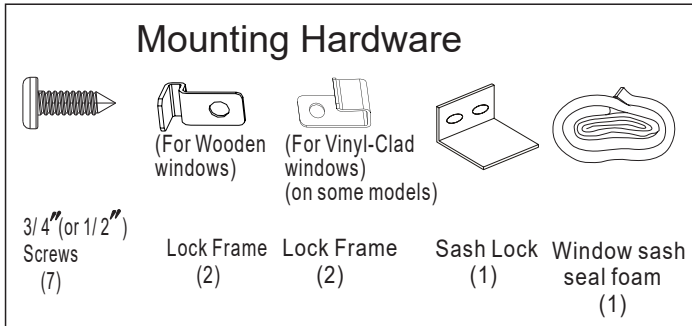

## 2 PREPARE AIR CONDITIONER

- A: Remove the air conditioner from the carton and place on a flat surface.
- B: Remove top rail and R1 hardware and weather stripping from the packaging material as shown in Fig. A(R1 hardware and weather stripping are only available for □15000Btu / h Energy star models).

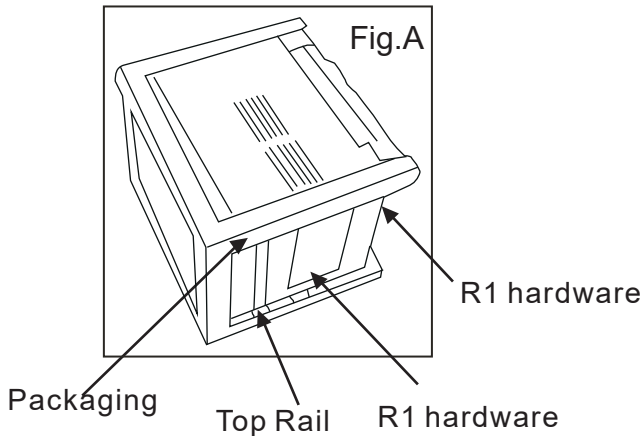
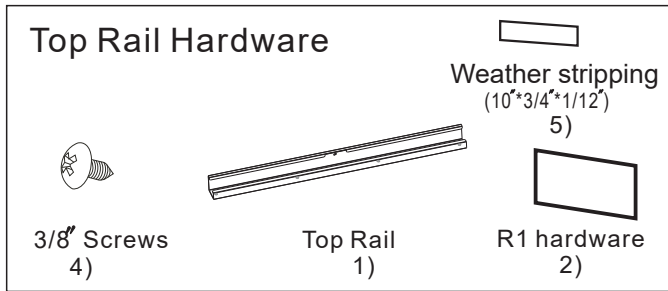

C: Align the hole in the top rail with those in the top of the unit as shown in Fig.B

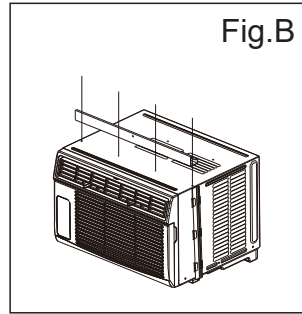

D: Secure the top rail to the unit with the 3/8" Screws as shown in Fig.C.

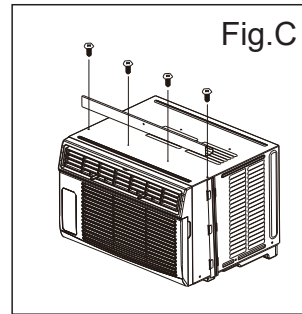

**NOTE:** For safety reasons, all four(4) screws MUST be securely fastened.

**NOTE:** The top rail hardware and the Fig.A, Fig.B and Fig.C are not applicable to the units more than 10000Btu/h. Before installing unit, the top rail must be assembled on the unit (For <10000Btu/h models only).

## 3 INSTALL THE ACCORDION PANELS

**NOTE:** Top rail and Sliding Panels at each side are offset to provide the proper pitch to the rear of (5/16 "). This is necessary for proper condensed water utilization and drainage. If you are not using the Side Panels for any reason, this pitch to the rear must be maintained.

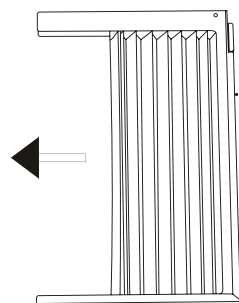

A. Place unit on floor, a bench or a table. Hold the Accordion Panel in one hand and gently pull back the center to free the open end. See Fig.1

B. Slide the free end "I" section of the panel directly into the cabinet as shown in Fig. 2. Slide the panel down. Be sure to leave enough space to slip the top and bottom of the frame into the rails on the cabinet.

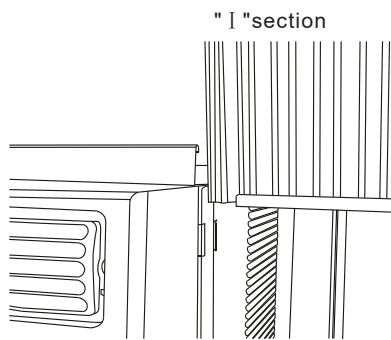

Fig.2

C. Once the panel has been installed on the side of the cabinet, make sure it sits securely inside the frame channel by making slight adjustments. Slide the top and bottom ends of the frame into the top and bottom rails of the cabinet. Fig .3.

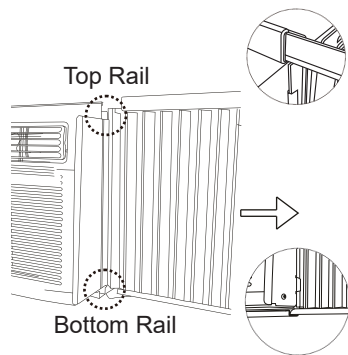

Fig.3

D. Slide the panel all the way in and repeat on the other side.

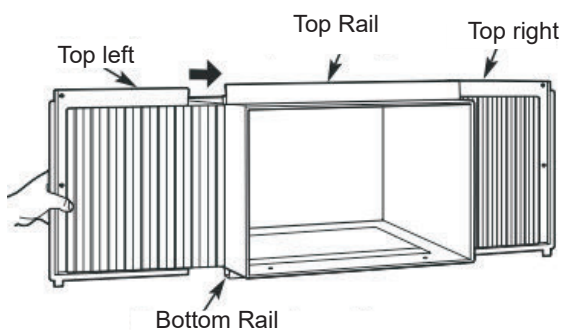

Fig.4

**NOTE:** If storm window blocks AC, see Fig. 11.

#### 4 SECURE THE ACCORDION PANELS

A. Keep a firm grip on the air conditioner, carefully place the unit into the window opening so the bottom of the air conditioner frame is against the window sill (Fig.5A and Fig.5B). Carefully close the window behind the top rail of the unit.

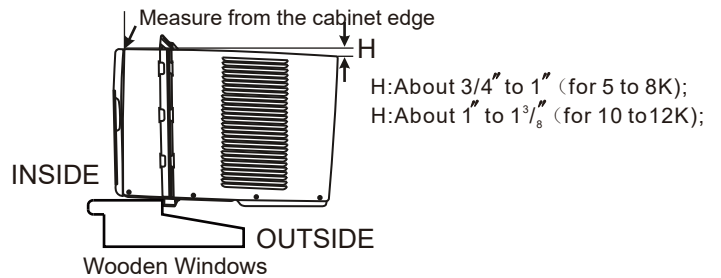

Fig.5A

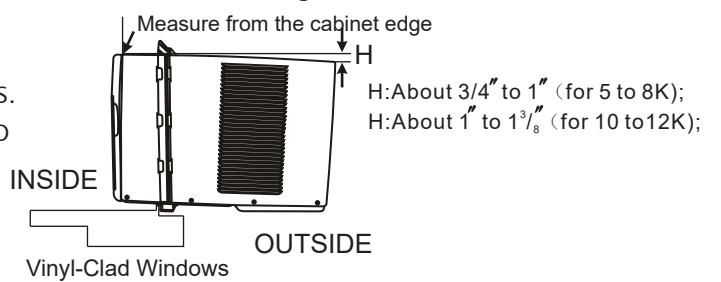

Fig.5B

**NOTE:** Check that air conditioner is tilted back about H (Fig.5A and Fig.5B) (tilted about 3° to 4° downward to the outside). After proper installation, condensate should not drain from the overflow drain hole during normal use, correct the slope otherwise.

B. Extend the side panels out against the window frame (Fig.6).

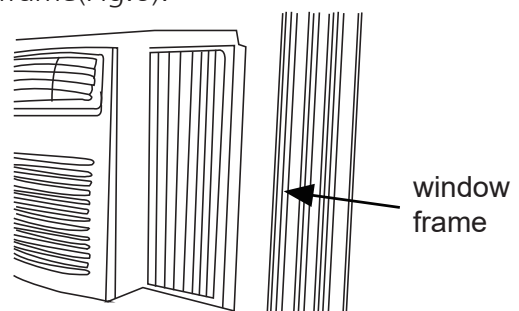

Fig.6

#### 5 INSTALL SUPPORT BRACKET

A. Place the frame lock between the frame extensions and the window sill as shown (Fig.7A for Wooden windows), (Fig.7B for Vinyl-Clad windows).

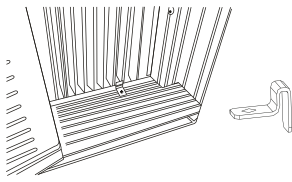

Fig.7A

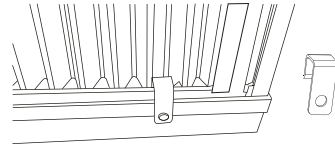

Fig.7B

## 6 DRIVE LOCKING SCREWS

A: For wooden windows:

Drive 1/2" (12.7 mm) locking screws through the frame lock and into the sill (Fig.8A).

NOTE: To prevent window sill from splitting, drill 1/8" (3mm) pilot holes before driving screws. Drive 1/2" (12.7mm) locking screws through frame holes into window sash (Fig.8B).

B: For Vinyl-Clad windows:

Drive 1/2" (12.7 mm) locking screws through the frame lock and into the window sash (Fig.8B).

NOTE: Before driving the screws, use a drill to drill 5 holes through the holes in the frame lock and frame extensions into the windows sash as shown (Fig. 8B).

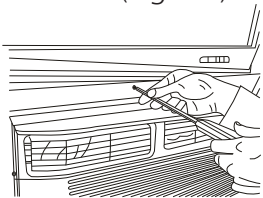

Fig.8A

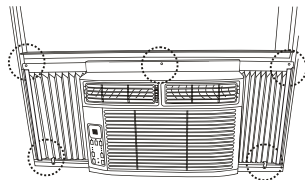

Fig.8B

C. To secure lower sash in place, attach right angle sash lock with 3/4" (19mm) or 1/2" (12.7mm) screw as shown(Fig.9).



Fig.9

D. Cut window sash seal foam and insert it in the space between the upper and lower sashes (Fig. 10).

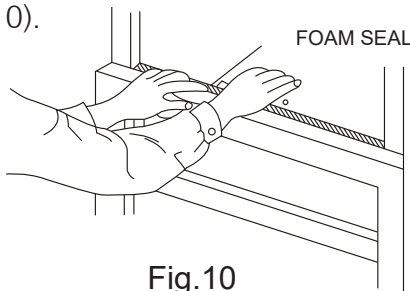

Fig.10

## 7 INSTALL R1 HARDWARE (only applicable to ≥15000Btu/h Energy star models )

In order to minimize air leaks and ensure optimal insulation, it is necessary to install the included R1 hardware to the side curtain. Follow the instructions below.

Step 1. After the unit is installed to the window, measure the inner width of the side curtain as shown (Fig.11).

Step 2. Remark a line on the provide R1 insulation panel according to a length 1/8" (3mm) less than the measured width in step 1, then cut the R1 insulation panel along the line (Fig .12).

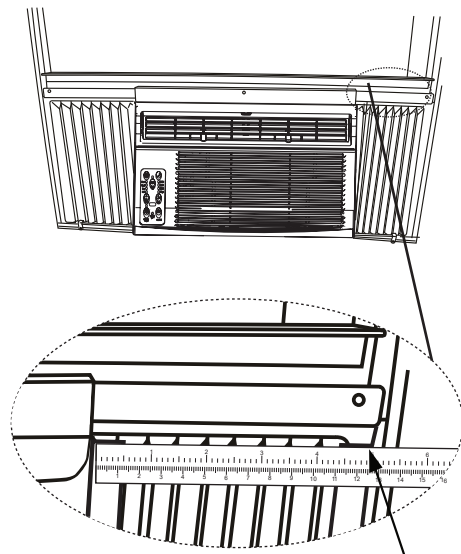

Measure the inner width of the side curtain

Fig.11

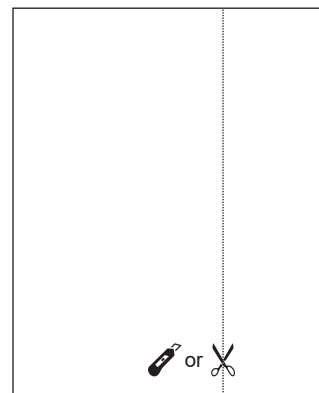

Fig.12

Step 3. Slide the R1 insulation panel into the side curtain, the side with pattern should facing the indoor side.(Fig.13)

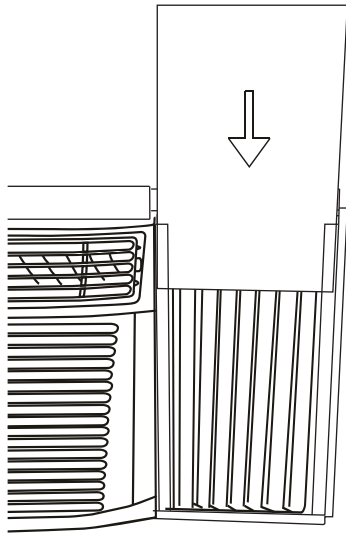

Fig.13

Step 4. Repeat on the other side.

**8 INSTALL WEATHER STRIPPING (only be applicable to Energy star models )**

In order to minimize air leaks between the room air conditioner and the window opening, trim the weather stripping with a proper length, peel off the protective backing and plug any gaps if needed (Fig .14).

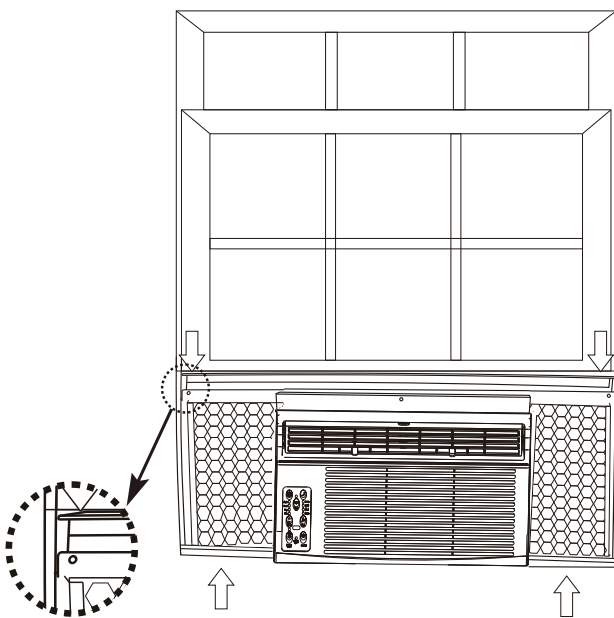

Fig.14

**If AC is Blocked by Storm Window**

Add wood as shown in Fig.15, or remove storm window before air conditioner is installed.

If Storm Window Frame must remain, be sure the drain holes or slots are not caulked or painted shut. Accumulated Rain Water or Condensation must be allowed to drain out.

**Removing AC From Window**

Turn AC off, and disconnect power cord. Remove sash seal from between windows, and unscrew safety sash lock.

Remove screws installed through frame and frame- lock.

Remove the R1 Panel and close (slide) side panels into frame.

Keeping a firm grip on air conditioner, raise sash and carefully remove.

Be carefully not to spill any remaining water while lifting unit from window. Store parts WITH air conditioner.

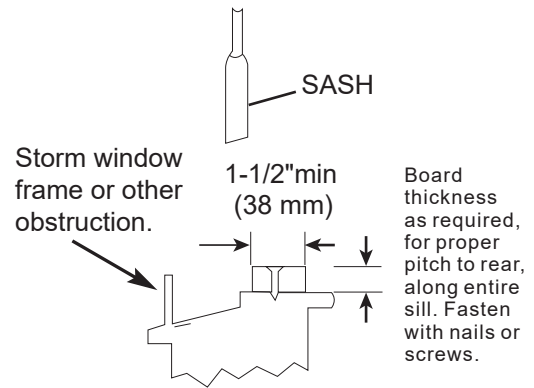

Fig.15



# Installation Instructions (for 15000 to 28500Btu/h)



## BEFORE YOU BEGIN

Read these instructions completely and carefully.  
**IMPORTANT**-Save these instructions for local inspector's use.  
**IMPORTANT**-Observe all governing codes and ordinances.  
 Note to Installer- Be sure to leave these instructions with the Consumer.  
 Note to Consumer- Keep these instructions for future reference.  
 Skill level- Installation of this appliance requires basic mechanical skills.  
 Completion time- Approximately 1 hour.  
 We recommend that two people install this product.  
 Proper installation is the responsibility of the installer.  
 Product failure due to improper installation is not covered under the Warranty.  
 You **MUST** use all supplied parts and use proper installation procedures as described in these instructions when installing this air conditioner.

## CAUTION

Do not, under any circumstances, cut or remove the third (ground) prong from the power cord. Do not change the plug on the power cord of the air conditioner. Aluminum house wiring may present special problems- consult a qualified electrician. When handling unit, be careful to avoid cuts from sharp metal edges and aluminum fins on front and rear coils.

## NOTE:

Save Carton and these Installation Instructions for future reference. The carton is the best way to store unit during winter, or when not in use.

## Preliminary Instructions

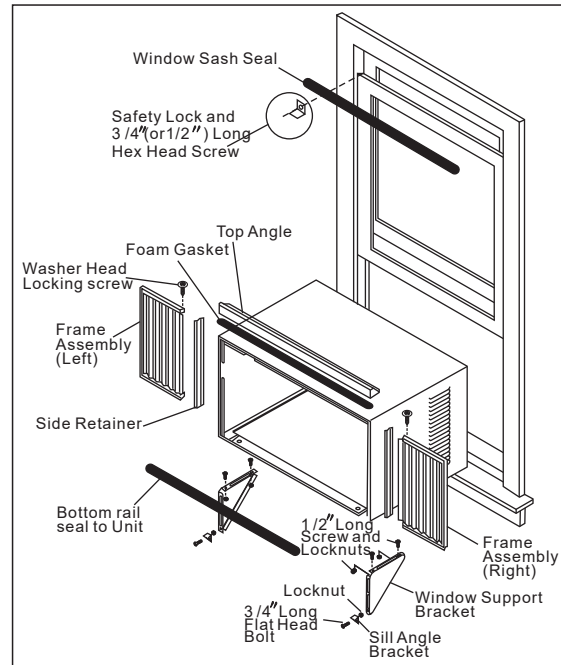

Do the following before starting to install unit. See illustrations below.

Check dimensions of your unit to determine model type:

Unit Height:	18 5/8 "	17 5/8 "
Unit Width:	26 1/2 "	23 5/8 "
Min. Window Opening:	19 1/2 "	18 1/2 "
Min. Window Width:	31 "	28 "
Max. Window Width:	42 "	40 1/2 "

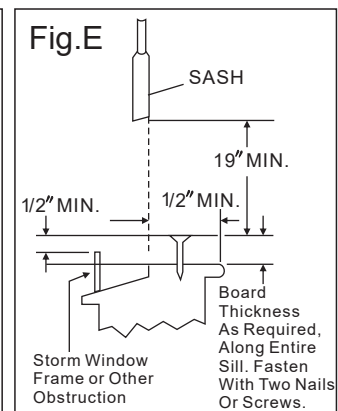
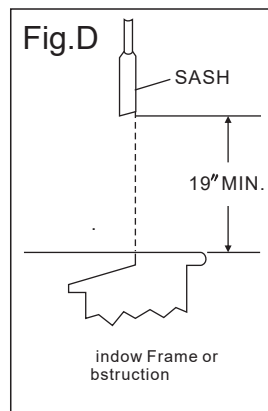

1. **Check window opening size**-- the mounting parts furnished with this air conditioner are made to install in a wooden sill double-hung window. The standard parts are for window dimensions listed above. Open sash to a minimum of 19 inches (483mm). See Fig.D.

2. **Check condition of window**-- all wood parts of window must be in good shape and able to firmly hold the needed screws. If not, make repairs before installing unit.

















3. **Check your storm windows**-- if your storm window frame does not allow the clearance required, correct by adding a piece of wood as shown in Fig.E, or by removing storm window while room air conditioner is being installed.

4. **Check for anything that could block airflow**- check area outside of window for things such as shrubs, trees, or awnings. Inside, be sure furniture, drapes, or blinds will not stop proper airflow.

5. **Check the available electrical service**- Power supply must be the same as that shown on the unit serial nameplate. Power cord is 48 inches long. Be sure you have an outlet near.

6. **Carefully unpack air conditioner**- Remove all packing material. Protect floor or carpet from damage. Two people should be used to move and install unit.

### Hardware(Packed with the unit)

	7/16 inch Locking screw and Flat washer for window panels	2 ea.
	3 / 4 (or 1/2)inch Long Hex-head Screw	7
	Safety Lock	1
	1 / 2 inch Long screw and Locknut	4ea.
	3 / 4 inch Long Flat Head Bolt and Locknut	2ea.
	Sill Angle Bracket	2
	Lock Frame(For Wooden windows)(on some models)	2
	3 / 4 inch Long Screw(on some models)	2
	Long hex-head locking screw for top angle, side retainer 5 / 16 inch Long	10
	Foam insert	2
	Window sash seal foam	1
	Safety Lock (for Vinyl-Clad window)(on some models)	2
	Locking screw # 10X 1 / 4 panhead Phillips screws (for Vinyl-Clad window)(on some models)	2
	R1 hardware	2
	Weather stripping (10*3/4*1/12')	5
	Sill angle bracket (on some models)	2
NOET:R1 hardware and Weather stripping is only for Energy star models(for ≥ 15000Btu/h models only).		

### Tools Required

A large flat blade screwdriver; Tape measure; Adjustable wrench or pliers; Pencil; Level Socket wrenches; Phillips Screwdriver.

## A. Window Mounting

### 1 Remove Air Conditioner from Cabinet

**NOTE:** Remove any packaging material from cabinet exterior.

1. Pull down front grille and remove filter. (See Fig.1).
2. Lift front grille upwards and place to one side.
3. Locate the four front screws and remove. These screws will be needed to re-install the front panel (see Fig.2).

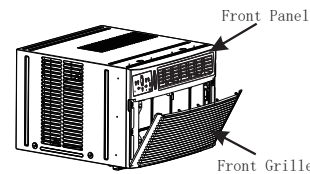

Fig.1

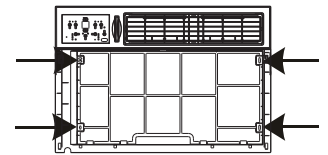

Fig.2

4. Push metal cabinet side to release plastic tabs on each side of front panel (see Fig.3).
5. Gently lift front panel off unit(see Fig.3A).
6. Disconnect the connector plug of the display panel from the unit and place front panel to one side(see Fig.4).

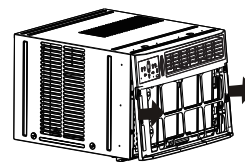

Fig.3

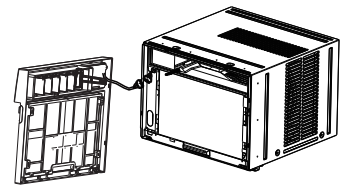

Fig.4

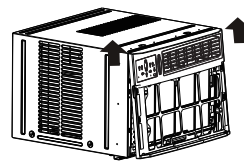

Fig.3A

7. Remove shipping screws from top of unit and also on the side by the base if installed(see Fig.5).
8. Hold the cabinet while pulling on the base pan handle, and carefully remove the unit.
9. Add two foam inserts to holes in top of cabinet where shipping screws were removed from (see Fig. 6)

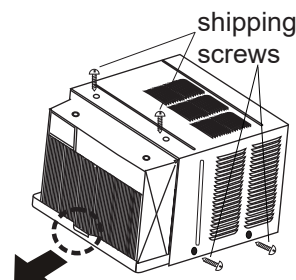

Fig.5

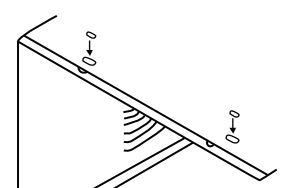

Fig.6

10. Your unit may come with internal packaging. This packaging must be removed prior to installing the air conditioner back into the cabinet.(see Fig .7).

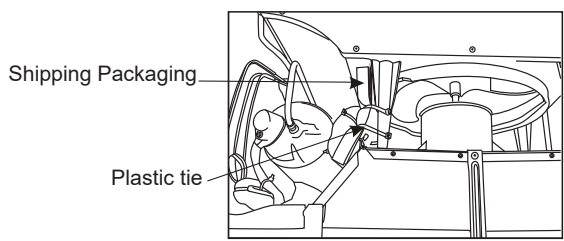

Fig.7

**2 Install top angle and side Bracket**

1. Attach foam gasket to top angle above holes as shown in Fig.6.
2. Install top angle and side retainers to cabinet as shown in Fig.8(10 screws).

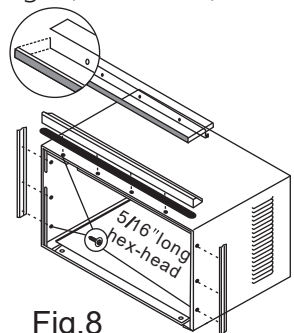

Fig.8

**3 Assemble Window Filler Panels**

1. Place cabinet on floor, a bench, or a table.
2. Slide "I" section of window filler panel into side retainer on the side of the cabinet (see Fig.9 & Fig.10). Do both sides.

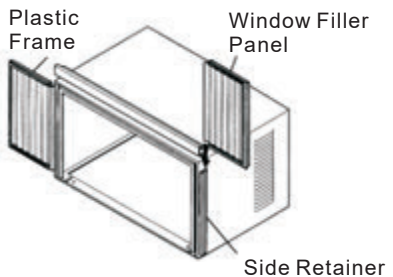

Fig.9

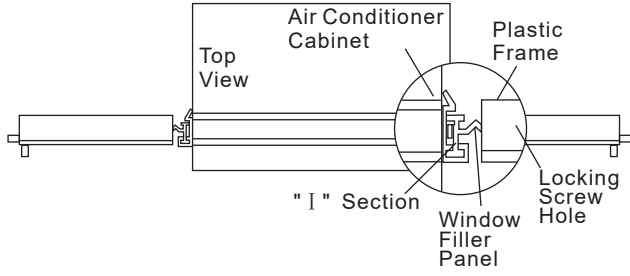

Fig.10

3. Insert top and bottom legs of window filler panel frame into channel in the top angle and bottom rail. Do both sides.
4. Insert washer head locking 7/16" screws (2) into holes in top leg of filler panel frame (see step 6). Do not totally tighten. Allow leg to slide freely. Screws will be tightened after section 6.

**4 Place Cabinet in window**

1. Open window and mark center of window inner sill as shown(Fig.11).
2. Place cabinet in window with bottom sill angle firmly seated over window sill as shown. Bring window down temporarily behind top angle to hold cabinet in place(Fig.12).

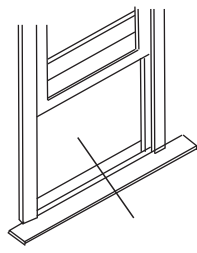

Fig.11

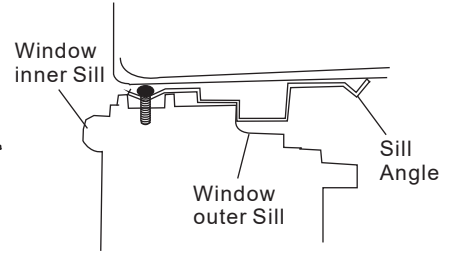

Fig.12

3. Shift cabinet left or right as needed to line up center of cabinet on center line marked on inner sill.
4. For wooden window: Fasten cabinet to window inner sill with two screws into holes (Fig.13) (You may wish to pre-drill pilot holes). For Vinyl-Clad window: Place two safety locks into the holes located in the bottom of the cabinet and drive two #10X1/4" pan-head Phillips locking screws through the safety locks into the cabinet as shown (Fig.13B).
5. Remove protective strip from adhesive side of Bottom Rail Foam Seal. Apply Seal over screws fastening bottom rail to window inner sill.



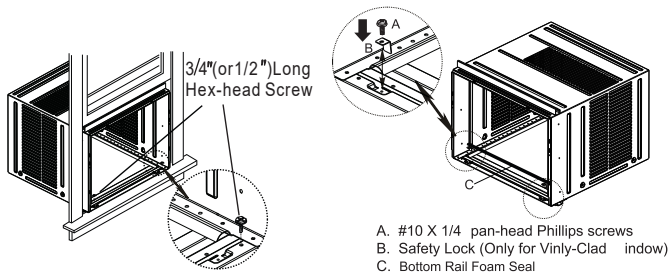

Fig.13

Fig.13B

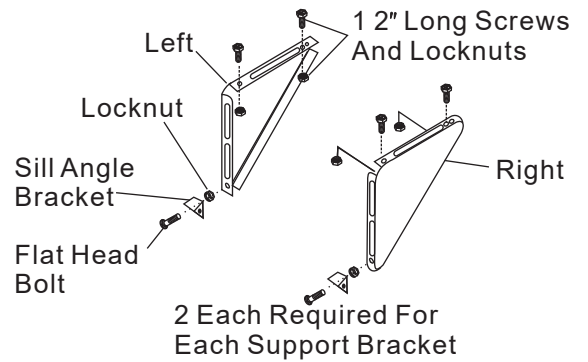

Fig.15B

## 5 Install Support Bracket

1. Hold each support bracket flush against outside of sill, and tight to bottom of cabinet as shown in Fig.15A. Mark brackets at top level of sill and remove.

2. Assemble sill angle bracket to support brackets at the marked position(Fig.15B).

Hand tighten, but allow for any changes later.

**NOTE:** Check that air conditioner is tilted back about  $1\frac{1}{4}$ " to  $1\frac{5}{8}$ " (tilted about  $3^\circ$  to  $4^\circ$  downward to the outside). After proper installation, condensate should not drain from the overflow drain hole during normal use,correct the slope otherwise (Fig. 14).

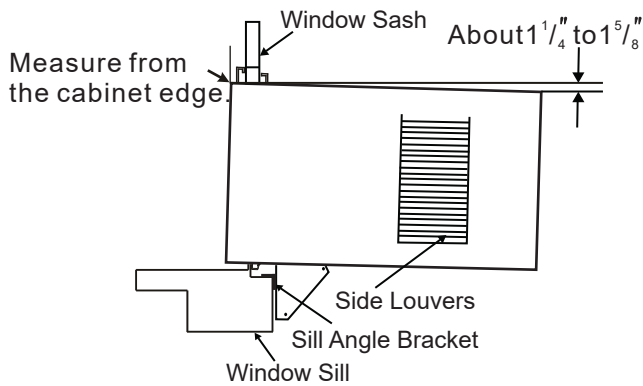

Fig.14

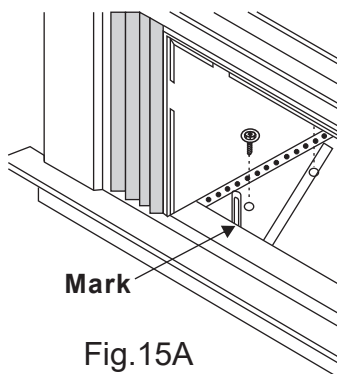

Fig.15A

3. Install support brackets(with sill angle brackets attached) to correct hole in bottom of cabinet as shown in Fig.16.

4. Tighten all 6 bolts securely.

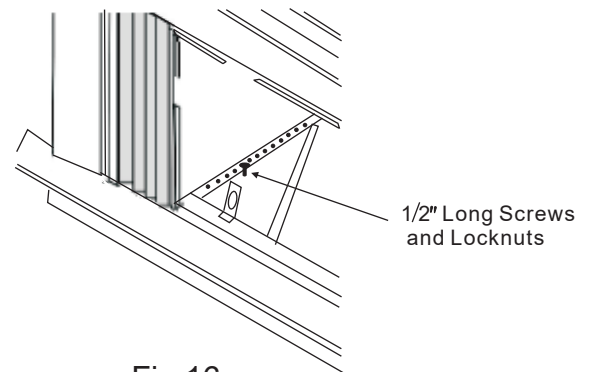

Fig.16

## 6 Extend Window Filler Panels

1. Carefully raise window to expose filler panel locking screws. Loosen screws so filler panels slide easily.

2. Extend panels to fill window opening completely. Tighten locking screws on top (Fig.17).

3. Close window behind top angle.

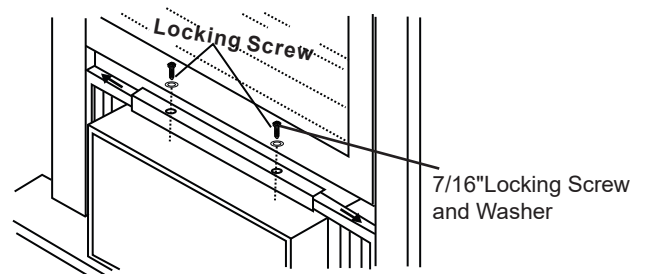

Fig.17

4. Attach the top angle to window frame: Use a 3/32" drill bit to drill one hole through the hole in the middle of top angle into the window frame, and drive one 3/4" (or 1/2") HEX-HEAD locking screw through hole in the middle of top angle into the window frame as shown (Fig.17A)

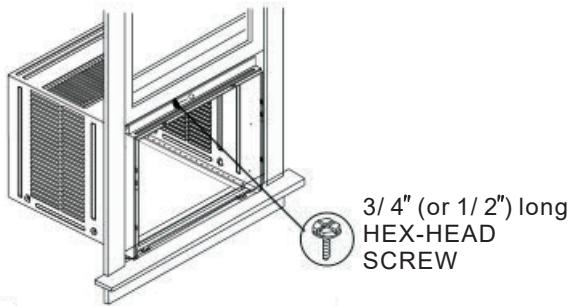
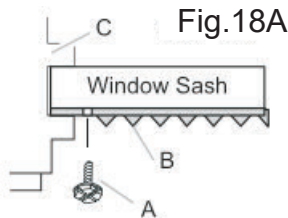

Fig.17A

### 7 Attach Window Filler Panels to Window Frame

1. Extend the window filler panels out against the window frame.
2. Use a 1/8" drill bit to drill a starter hole through the hole in the top leg of each window filler panel and into the window sash (Fig. 18A and Fig. 18B). Connect with one 3/4" (or 1/2") long hex head screw.



- A. 3/4" (or 1/2") long hex head screw
- B. Left-hand Window Filler Panel Top Leg
- C. Window channel

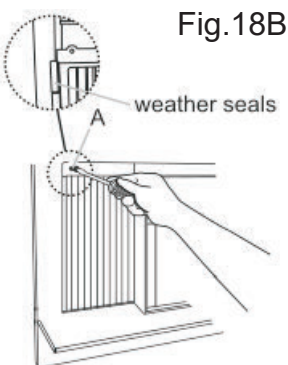

A. 3/4" (or 1/2") long hex head screw

3. Attach the Lock Frames to the window sill using two 3/4" (19mm) screws (Fig.18C) (on some models)

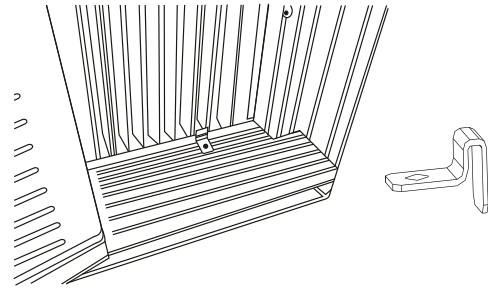

Fig.18C

### 8 Install Window Sash Seal and Safety Lock

1. Trim sash seal to fit window width. Insert into space between upper and lower sashes (Fig.18).



Fig.18

2. Attach right angle safety lock (Fig. 19).

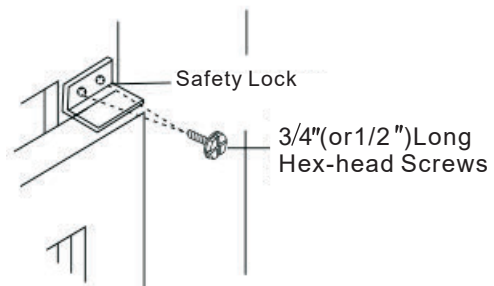

Fig.19

## 9 Install Chassis into Cabinet and Install Front to Unit

1. Lift air conditioner and carefully slide into cabinet leaving 6 inches protruding.
2. DO NOT push on controls or finned coils.
3. Be sure chassis is firmly seated towards rear of cabinet.
4. Installation of front is the reverse of removal outlined in Section 1.

## 10 INSTALL R1 HARDWARE (only applicable to $\geq 15000$ Btu/h Energy star models)

In order to minimize air leaks and ensure optimal insulation, it is necessary to install the included R1 hardware to the side curtain. Follow the instructions below.

Step 1. After the unit is installed to the window, measure the inner width of the side curtain as shown (Fig.20).

Step 2. Remark a line on the provided R1 insulation panel according to a length  $1/8$  " (3mm) less than the measured width in step 1, then cut the R1 insulation panel along the line (Fig. 12).

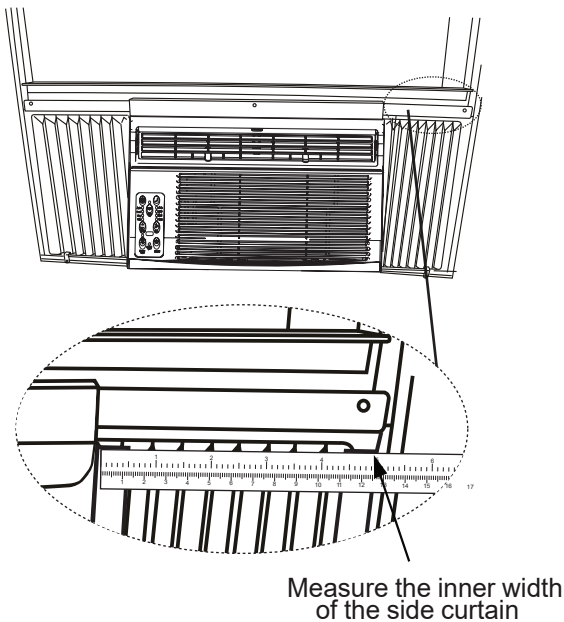

Fig.20

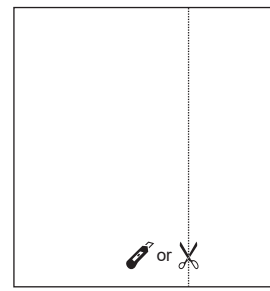

Fig.21

Step 3. Slide the R1 insulation panel into the side curtain, the side with pattern should facing the indoor (Fig. 22).

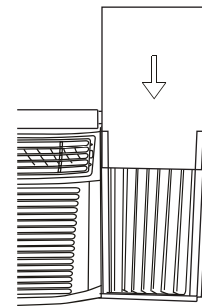

Fig.22

Step 4. Repeat on the other side.

## 11 INSTALL WEATHER STRIPPING (only applicable to Energy star models)

In order to minimize air leaks between the room air conditioner and the window opening, trim the weather stripping with a proper length, peel off the protective backing and plug any gaps if needed (Fig.23).

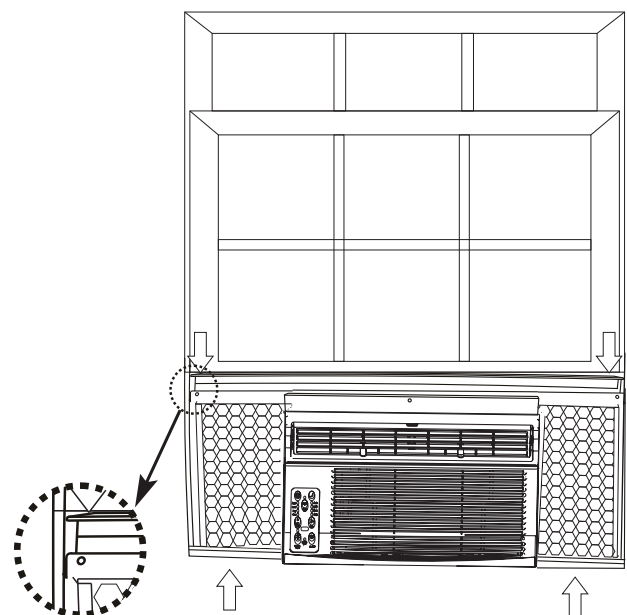

Fig.23

## B. Thru-The-Wall Installation

**NOTE:** Consult local building codes prior to installation or a qualified carpenter.

### 1 Select Wall Location

The air conditioner has a slide-out chassis, so that it can be installed through an outside wall as specified below:

Max. Wall thickness: 12" or 10"

**IMPORTANT:** Side louvers must never be blocked.

**NOTE:** All parts needed for Thru-The-Wall Installation are provided, except a wood frame, shims, and 10 wood screws(#10-1" long minimum).

Select a wall surface that:

1. does not support major structural loads such as the frame construction at ends of windows, and under truss-bearing points, etc.
2. does not have plumbing or wiring inside.
3. is near existing electrical outlets or where another outlet can be installed.
4. is not blocked to the area to be cooled.
5. allows unblocked airflow from rear sides and end(outside) of installed air conditioner.

### 2 Prepare Wall

1. Prepare wall in frame construction (including brick and stucco veneer). Working from inside the room, find wall stud nearest the center of area where air conditioner will be installed (by sounding wall or by magnetically finding nails).
2. Cut or knock out a hole on each side of center stud.
3. Measure between inside edges of every other stud as shown in Fig.1.

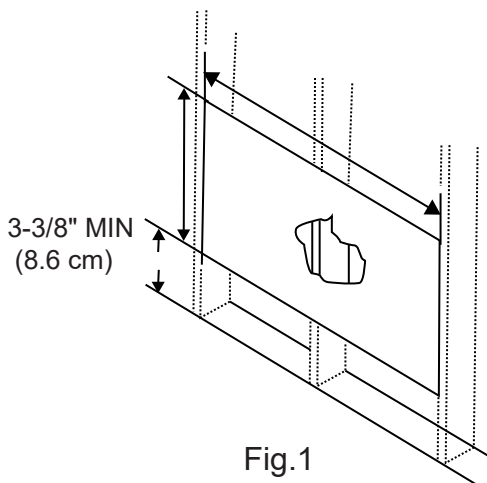

Fig.1

Carefully measure and cut an opening with the following dimensions depending on your model. See Fig.1 and Fig.2.

WIDTH " X " = inside model width plus twice the thickness of framing material used.  
 HEIGHT " Y " = inside model height plus twice the thickness of framing material used.

Inside Frame Height: 18-7/8"(47.9cm) or 18" (45.7cm)  
 Inside Frame Width: 26-3/4"(67.9cm) or 23-7/8"(60.6cm)

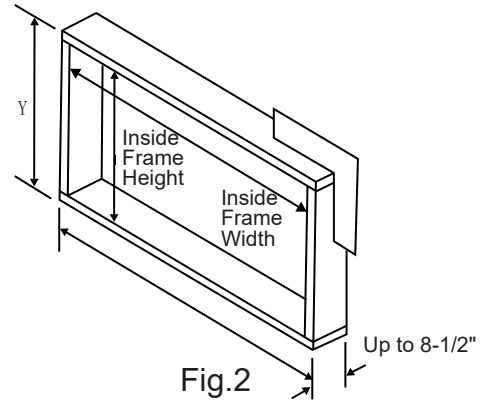

Fig.2

4. Build a wooden frame with the INSIDE dimensions of your model listed above. (Remember to measure twice). Frame depth should be the same as wall thickness. Fill in the space from the opening to the studs with wood spacers, as shown.

5. Nail frame to spacers to spacers with front flush with drywall.

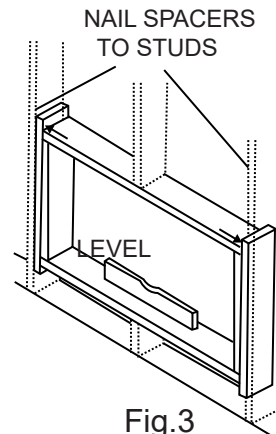

Fig.3

**NOTE:** If wall thickness is 8-1/2" or more, add aluminum flashing over bottom of frame opening to assure no water can enter area between inner and outer wall.

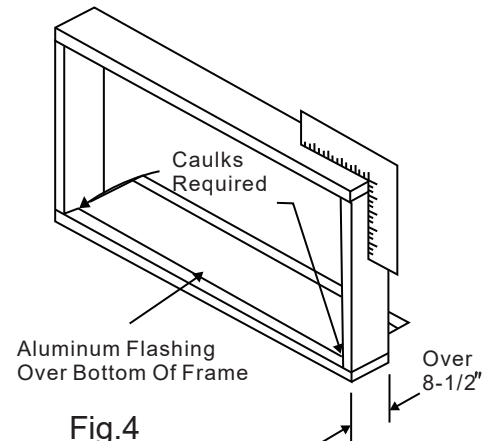

Fig.4

### 3 Prepare and Install Cabinet

1. Slide chass is from cabinet. Refer back to Step one of Window Mounting.
2. Place cabinet into opening with bottom rail resting firmly on bottom board of wooden frame.
3. Position cabinet to achieve proper slope for water removal.(See Fig.5 below.)
4. Secure bottom rail to wood frame with two large wood screws 1 "(2.5cm) long using the two holes in the bottom of the channel resting on frame.(See Fig.6 ).

**NOTE:** Check that air conditioner is tilted back about 1 1/4" to 1 5/8" (tilted about 3° to 4° downward to the outside). After proper installation, condensate should not drain from the overflow drain hole during normal use, correct the slope otherwise (Fig.14).

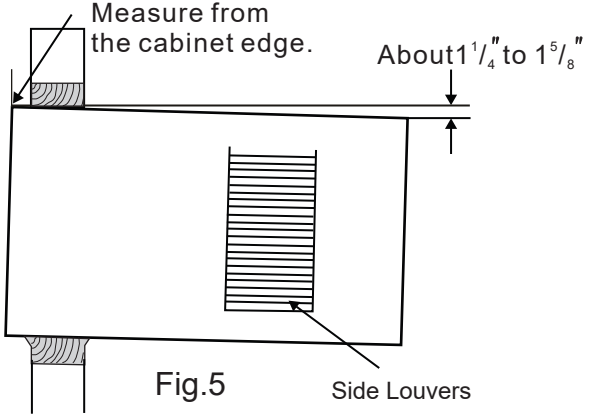

Fig.5

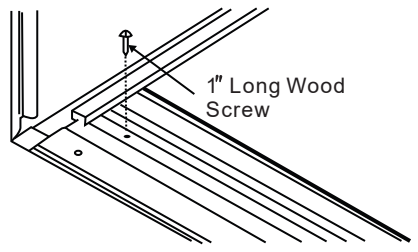

Fig.6

Refer to Step 5 of Window Mounting for assembly of support brackets. A wooden strip nailed to the outside wall should be used in conjunction with sill support angle brackets.

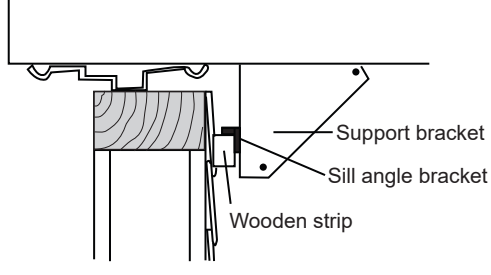

Fig.7

5. Screw or nail cabinet wooden frame using shims if frame is oversized to eliminate distortion. See Fig.8. Remember to maintain proper slope as described in Step 3.

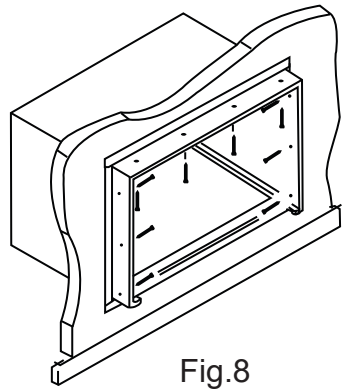

Fig.8

6. Install chassis into cabinet by following all steps in Steps 8 of Window Mounting.
  - OPTIONAL:** Caulking and installation of trim on interior wall may be done. You can buy wood from your local lumber or hardware supply. On the outside, caulk openings around top and sides of cabinet, and all sides of wood sleeve to the opening.
  - NOTE:** See Step 5, Item 3 of Window Mounting Instructions for bottom rail seal location.

### C. Masonry Construction

1. Cut or build a wall opening in the masonry wall similar to the frame construction (refer to Step 2 of Thru-the-wall Installation for a wall thickness greater than 8-1/2 " ).
2. Secure cabinet in place using masonry nails, or the right masonry anchor screws. (Another way to secure cabinet is to build a frame in the masonry wall such as the one shown in Fig. 3 of Step 2 Prepare Wall. Securely anchor frame to masonry wall. This way gives very good louver clearance on either side of cabinet.)
3. Install a lintel to support masonry wall above cabinet. Existing holes in cabinet can be used and/or additions holes can be drilled to fasten cabinet at various positions. Be sure that side louver clearance is in accordance with Step 1 Select Wall Location.
4. Install exterior cabinet support brackets as shown in Step 2 of Thru-the-wall installation. Caulk or flash if needed, to provide a weather-tight seal around top and sides of cabinet.
5. To complete installation, apply wood trim molding around room side projection of cabinet.



# Normal Sounds

## High Pitched Chatter

High efficiency compressors may have a high pitched chatter during the cooling cycle.

## Sound of Rushing Air

At the front of the unit, you may hear the sound of rushing air being moved by the fan.

## Gurgle/Hiss

"Gurgling or hissing" noise may be heard due to refrigerant passing through evaporator during normal operation.

## Vibration

Unit may vibrate and make noise because of poor wall or window "construction or incorrect" installation.

## Pinging or Switching

Droplets of water hitting condenser during normal operation may cause "pinging or switching" sounds. This noise can be reduce by removing the water plug at the bottom of unit's rear as shown below. Removing this plug will lower the Energy Efficiency of your unit.

Note: Don't try to drill any holes on the base pan to eliminate the normal sounds, otherwise it will void the warranty.

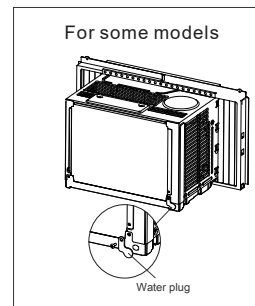
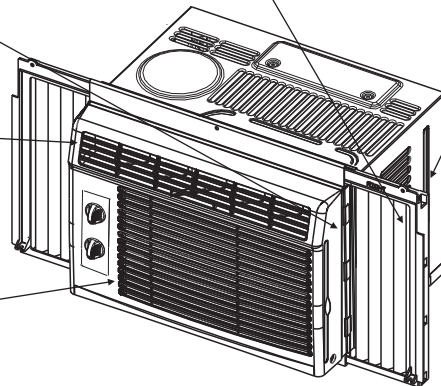

Normal Sounds

## High Pitched Chatter

High efficiency compressors may have a high pitched chatter during the cooling cycle.

## Sound of Rushing Air

At the front of the unit, you may hear the sound of rushing air being moved by the fan

## Gurgle/Hiss

"Gurgling or hissing" noise may be heard due to refrigerant passing through evaporator during normal operation.

## Vibration

Unit may vibrate and make noise because of poor wall or window construction or incorrect installation.

## Pinging or Switching

Droplets of water hitting condenser during normal operation may cause "pinging or switching" sounds. This noise can be reduce by removing the water plug at the bottom of unit's rear as shown below. Removing this plug will lower the Energy Efficiency of your unit.

Note: Don't try to drill any holes on the base pan to eliminate the normal sounds, otherwise it will void the warranty.

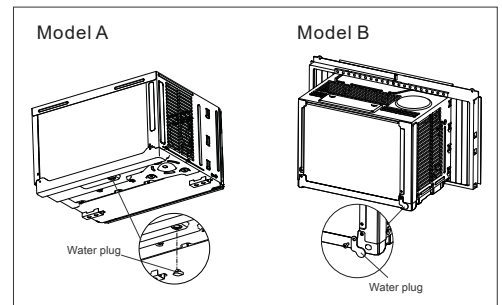
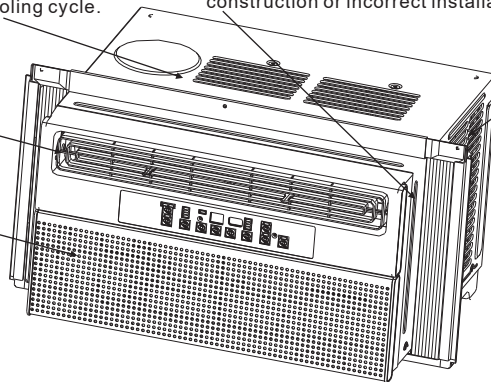

## High Pitched Chatter

High efficiency compressors may have a high pitched chatter during the cooling cycle.

## Sound of Rushing Air

At the front of the unit, you may hear the sound of rushing air being moved by the fan

## Gurgle/Hiss

"Gurgling or hissing" noise may be heard due to refrigerant passing through evaporator during normal operation.

## Vibration

Unit may vibrate and make noise because of poor wall or window installation.

## Pinging or Switching

Droplets of water hitting condenser during normal operation may cause pinging or switching sounds.

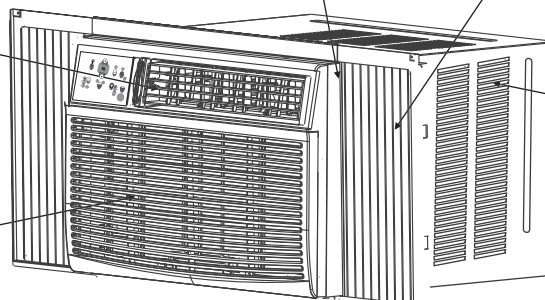

## NOTE:

All the illustrations in this manual are for explanation purpose only. The air conditioner you have may be slightly different. The actual shape shall prevail.

# Air Conditioner Features

## ⚠ WARNING

To reduce the risk of fire, electric shock, or injury to persons, read the IMPORTANT SAFETY INSTRUCTIONS before operating this appliance.

## ⚠ CAUTION

Please always wait 3 minutes when turning unit off then on again, and when changing from cool to fan and back to cool. This prevents compressor from overheating & possible circuit breaker tripping.

**To begin operating the air conditioner, follow these steps:**

1. Set the thermostat to the highest number (coldest or cooler setting).
2. Set the selector control to the highest COOL setting.
3. Adjust the louver for comfortable air flow (see Air Directional Louvers).
4. Once the room has cooled, adjust the thermostat to the setting you find most comfortable.
5. Make sure that the air flow inside and outside are not obstructed by anything.

## Air Directional Louvers

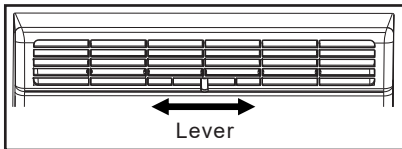

**Air Direction  
for 05K, 06K**

The louvers will allow you to direct the air flow Left or Right throughout the room as needed. Move the Levers from side to side until the desired Left/Right direction is obtained.

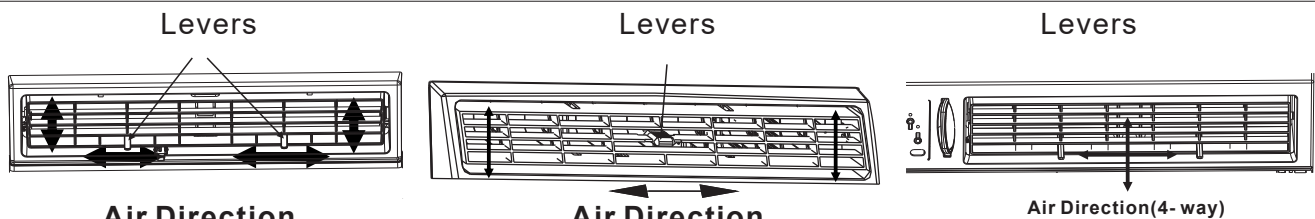

for 06K, 08K, 10K, 12K, 14.5K, 15K, 18K, 25K, 28.5K

The louvers will allow you to direct the air flow Up or Down (on some models) and Left or Right throughout the room as needed. Pivot horizontal louvers until the desired Up/Down direction is obtained. Move the Lever(s) from side to side until the desired Left/Right direction is obtained.

## Fresh Air Vent Control (for 10-14.5K MODELS)

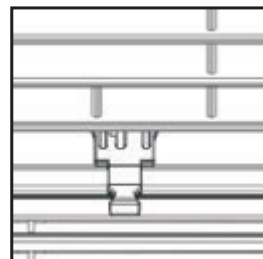
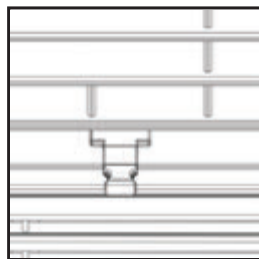
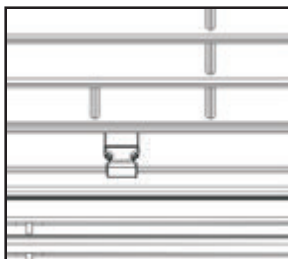

**Fig. A (VENT CLOSED) Fig. B (VENT OPEN) Fig. C (VENT & EXHAUST OPEN)**

The Fresh Air Vent allows the air conditioner to:

1. Recirculate inside air - Vent Closed (See Fig.A)
2. Draw fresh air into the room- Vent Open (see Fig.B)
3. Exchange air from the room and draws fresh air into the room - Vent and Exhaust Open (see Fig.C)

## Fresh Air Vent Control (on 15~28.5K models):

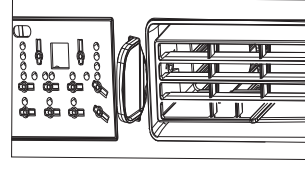
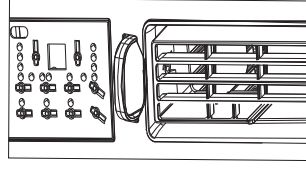
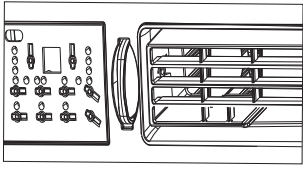
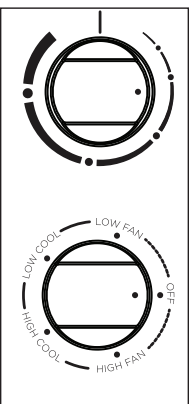
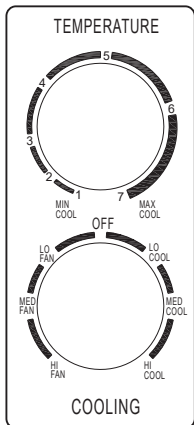
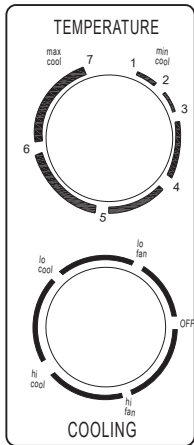

Fig. A (VENT CLOSED) Fig. B (VENT OPEN)

Fig. C (VENT & EXHAUST OPEN)

### The Fresh Air Vent allows the air conditioner to:

1. Recirculate inside air - Vent Closed (See Fig.A)
2. Draw fresh air into the room- Vent Open (see Fig.B)
3. Exchange air from the room and draws fresh air into the room - Vent and Exhaust Open (see Fig.C)



## MECHANICAL CONTROL OPERATING INSTRUCTIONS

### NOTE:

The controls featured in this manual are representative of many available models. Your model may offer slightly different features.

### Cool Mode

The desired cool setting is selected by rotating the knob to the right to the appropriate location.

**HI COOL(HIGH COOL)** has maximum cooling effect and airflow.

**LO COOL(LOW COOL)** has minimum cooling effect and airflow.

**MED COOL** has the intermediate cooling effect and airflow(on some models).

OFF will completely shut off the unit.

**NOTE:** If your unit is equipped with a vent handle, keep it closed for maximum efficiency.

### Fan Mode

Rotate the knob to the left to select your choice of fan speeds for air circulation.

**NOTE:** When selecting a fan speed, the compressor will not run. On models with a vent control, this mode can be used to remove stale air from the room, or to draw fresh air into the room. Check the section " Fresh Air Vent Control".

### Thermostat

The thermostat is used to set the desired room temperature when the unit is being operated in the **COOL MODE**.

To set the desired room temperature, rotate the thermostat switch to the desired setting. After the set temperature is achieved the thermostat will automatically start and stop the compressor in order to maintain the desired set temperature.

Rotate the thermostat selector clockwise for higher cool settings. Higher cool settings will provide lower room temperature. Rotate the thermostat selector counter clockwise for lower cool settings. Lower cool settings will provide higher room temperature.

## ELECTRONIC CONTROL OPERATING INSTRUCTIONS

**NOTE:** Different models have different control buttons and indicator lights. Not all the control buttons and indicator lights describing below are available for the unit you purchased. Please check the control panel of the unit you purchased. The unit can be controlled by the unit control alone or with the remote.

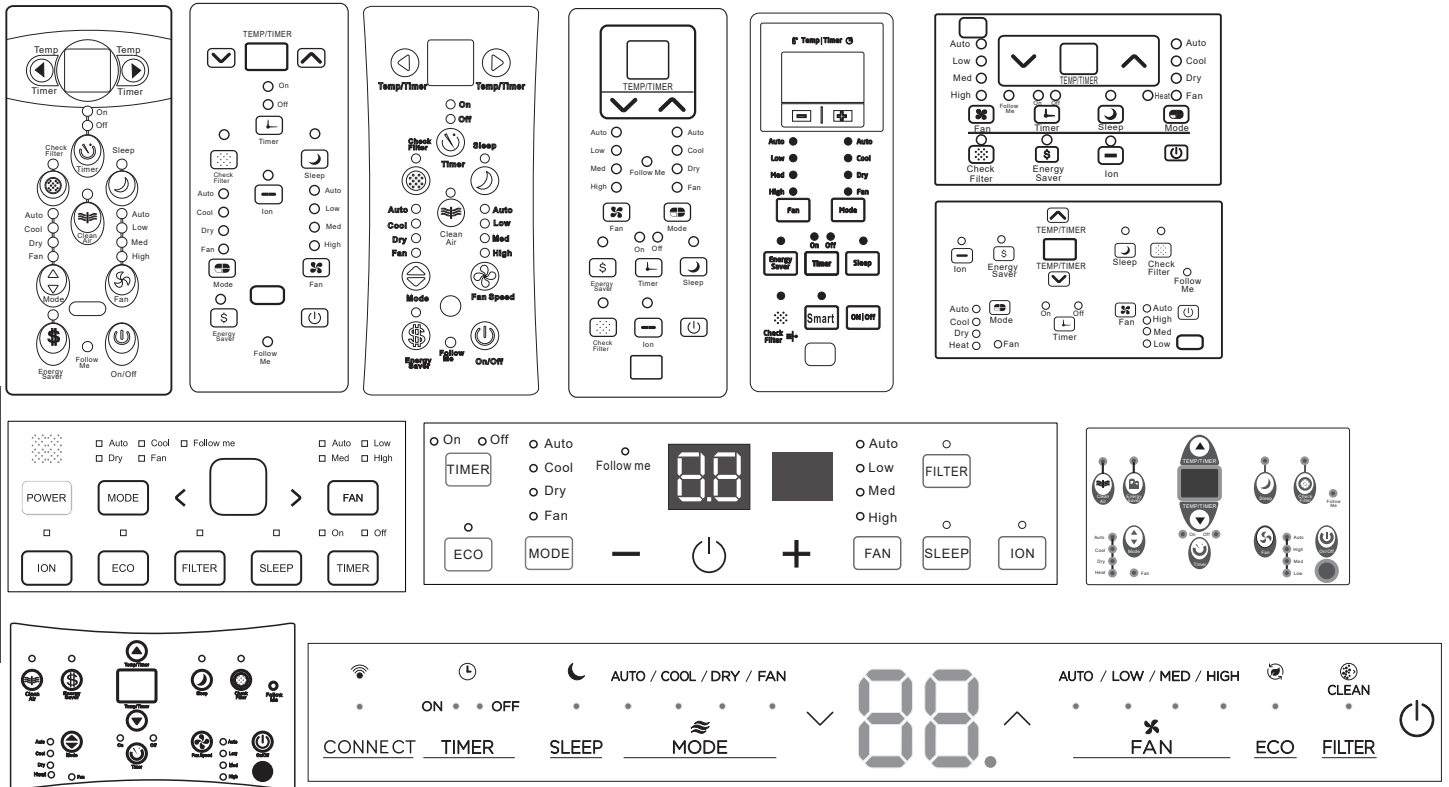

Air Conditioner Features

**NOTE:** Ion or clear air may be instead of SMART or WIRELESS or CONNECT for some models. Heat, clean air, ion, smart, Wireless, Connect and follow me features are optional. Ion, clean air is not applicable for R32/R290 units. Ion, clean air, smart, wireless and connect features may not be applicable for some models.

**NOTE:** The outline of the operation panel is based on typical model, the function is the same with your air conditioner while some difference may exist in appearance.

### TO TURN UNIT ON OR OFF:

Press POWER button to turn unit on or off.

**NOTE:** The unit will initiate automatically the Energy Saver function under Cool, Dry and Auto modes.

### CLEAN AIR (ION)/SMART (WIRELESS or CONNECT) FEATURE: (on some models)

Press Clean Air (ION) button, the ion generator is energized and will help to remove pollen and impurities from the air, and trap them in the filter. Press SMART (WIRELESS or connect) button for 3 seconds to turn off the unit and initiate SMART (WIRELESS or connect) connection mode.

### TO CHANGE TEMPERATURE SETTING:

Press UP/DOWN button to change temperature setting.

**NOTE:** Press or hold either UP or DOWN button until the desired temperature is shown on the display.

This temperature will be automatically maintained anywhere between 62°F (17°C) and 86°F (30°C).

If you want the display to read the actual room temperature, see "To Operate on Fan Only" section.

**SLEEP FEATURE:**

Press Sleep button to initiate the sleep mode. In this mode the selected temperature will increase (cooling) or decrease (heating) by 2°F/1 (or 2)°C 30 minutes after the mode is selected. The temperature will then increase (cooling) or decrease (heating) by another 2°F/1 (or 2)°C after an additional 30 minutes. This new temperature will be maintained for 6 or 7 hours before it returns to the originally selected temperature. This ends the Sleep mode and the unit will continue to operate as originally programmed. The Sleep mode program can be cancelled at any time during operation by pressing the Sleep button again.

**TO ADJUST FAN SPEEDS:**

Press Fan button to select the Fan Speed in four steps-Auto, Low, Med or High. Each time the button is pressed, the fan speed mode is shifted. For some models, the fan speed can not be adjusted.

**CHECK FILTER FEATURE:**

Press Check filter button to initiate this feature. This feature is a reminder to clean the Air Filter for more efficient operation. The LED(light) will illuminate after 250 hours of operation. To reset after cleaning the filter, press the Check Filter button and the light will go off.

**ENERGY SAVER FEATURE:**

Press Energy saver button to initiate this function. This function is available on COOL, DRY, AUTO (only AUTO-COOLING and AUTO-FAN) modes. The fan will continue to run for 3 minutes after the compressor shuts off. The fan then cycles on for 2 minutes at 10 minute intervals until the room temperature is above the set temperature, at which time the compressor turns back on and Cooling Starts.

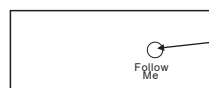
**FOLLOW ME FEATURE:(on some models)**

Light flashes or illuminates

This feature can be activated from the remote control ONLY. The remote control serves as a remote thermostat allowing for the precise temperature control at its location.

To activate the Follow Me feature, point the remote control towards the unit and press the Follow Me button. The remote display is actual temperature at its location. The remote control will send this signal to the air conditioner every 3 minutes interval until press the Follow Me button again. If the unit does not receive the Follow Me signal during any 7 minutes interval, the unit will beep to indicate the Follow Me mode has ended.

**TO SELECT THE OPERATING MODE:**

To choose operating mode, press Mode button. Each time you press the button, a mode is selected in a sequence that goes from Auto, Cool, Dry, heat (cooling only models without) and Fan. The indicator light beside will be illuminated and remained on once the mode is selected. The unit will initiate automatically the Energy Saver function under Cool, Dry, Auto (only Auto-Cooling and Auto-Fan) modes.

To operate on COOL mode:

- Choose Cool Mode to set the cooling function. Use the Up and Down buttons to choose the desired temperature. When Cool Mode is selected, the fan speed can be adjusted by pressing the fan button.

To operate on HEAT mode (cooling only models without):

- Choose Heat Mode to set the heating function. Use the Up and Down buttons to choose the desired temperature. When heat Mode is selected, the fan speed can be adjusted by pressing the fan button.

**NOTE:** For some models, the fan speed can not be adjusted under HEAT mode.

To operate on Auto feature:

- When you set the air conditioner in AUTO mode, it will automatically select cooling, heating(cooling only models without), or fan only operation depending on what temperature you have selected and the room temperature.
- The air conditioner will control room temperature automatically round the temperature point set by you.
- In this mode, the fan speed cannot be adjusted, it starts automatically at a speed according to the room temperature.

To operate on Fan Only:

- Use this function only when cooling is not desired, such as for room air circulation or to exhaust stale air(on some models). (Remember to open the vent during this function, but keep it closed during cooling for maximum cooling efficiency.) You can choose any fan speed you prefer.
- During this function, the display will show the actual room temperature, not the set temperature as in the cooling mode.
- In Fan only mode, the temperature is not adjusted.

To operate on Dry mode:

- In this mode, the air conditioner will generally operate in the form of a dehumidifier. Since the conditioned space is a closed or sealed area, some degree of cooling will continue. On Dry mode, the fan speed is controlled at Low automatically.

### TIMER: AUTO START/STOP FEATURE:

- Press Timer button, the TIMER ON or TIMER OFF indicator light illuminates. It indicates the Auto Start or Auto Stop program is initiated. For some units, keep pressing the Timer button will cancel the timer settings.
- Press or hold the UP or DOWN button to change the Auto time by 0.5 hour increments, up to 10 hours, then at 1 hour increments up to 24 hours. The control will count down the time remaining until start.
- The selected time will register in 5 seconds, and the system will automatically revert back to display the previous temperature setting or room temperature when the unit is on.(when the unit is off, there is no display.)

- Turning the unit ON or OFF at any time or adjusting the timer setting to 0.0 will cancel the Auto Start/Stop timed program.

### DISPLAYS:

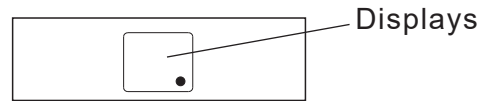

Shows the set temperature in " °C " or " °F " and the Auto-timer settings. While on Fan only mode, it shows the room temperature. If the room temperature is too high or low, it will display " HI " or " LO " .

Error codes:

AS - Room temperature sensor error

ES -Evaporator temperature sensor error

**NOTE:** " • " is displayed as shown in the above picture.

HS -Electric heating sensor error(on some models);

CS -Condenser temperature sensor error (on some models);

OS -Outside temperature sensor error (on some models);

E7 -Unit malfunction(on some models).

**NOTE:**When error occurs,unplug the unit and plug it back in.If error repeats, call for service.

### NOTE:

If the unit breaks off unexpectedly due to the power cut, it will restart with the previous function setting automatically when the power resumes.

### ADDITIONAL THINGS YOU SHOULD KNOW

Now that you have mastered the operating procedure, here are more features in your control that you should become familiar with.

- The Cool circuit has an automatic 3 minutes time delayed start if the unit is turned off and on quickly.

This prevents overheating of the compressor and possible circuit breaker tripping.The fan will continue to run during this time.

- The control is capable of displaying temperature in degrees Fahrenheit or degrees Celsius. To convert from one to the other, press and hold the Up and Down buttons at the same time for 3 seconds.

# Care and Cleaning

## ⚠ CAUTION

Clean your air conditioner occasionally to keep it looking new. **Be sure to unplug the unit before cleaning to prevent shock or fire hazards.**

### Air Filter Cleaning

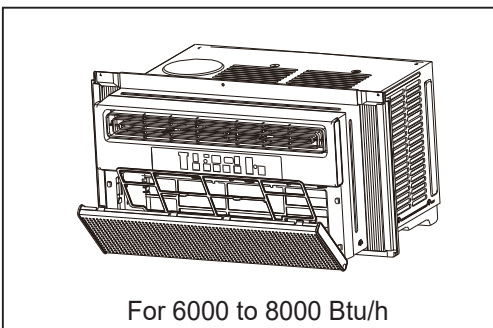
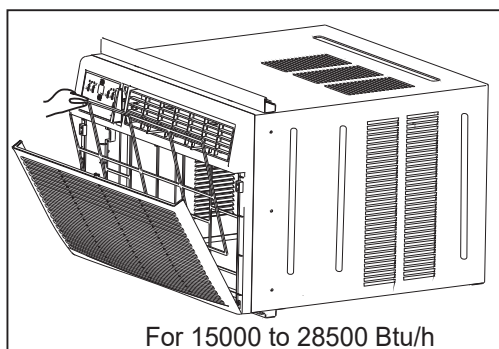
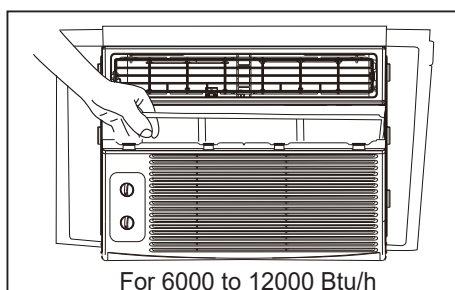
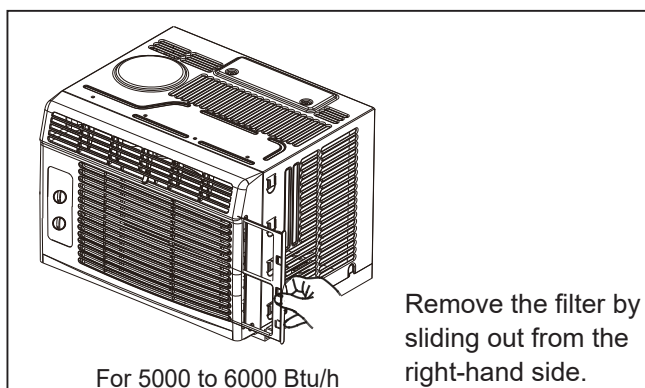

The air filter should be checked at least once a month to see if cleaning is necessary. Trapped particles in the filter can build up and cause an accumulation of frost on the cooling coils.

- Push the vent handle to the Vent Closed position (where applicable). Open the front panel.
- Take the filter by the center and pull up and out.
- Wash the filter using liquid dishwashing detergent and warm water. Rinse filter thoroughly. Gently shake excess water from the filter. Be sure the filter is thoroughly dry before replacing. Instead of washing, you may vacuum the filter clean.

**Note:** Never use hot water over 40°C(104°F) to clean the air filter. Never attempt to operate the unit without the air filter.

### Cabinet Cleaning

- Be sure to unplug the air conditioner to prevent shock or fire hazard. The cabinet and front may be dusted with an oil-free cloth or washed with a cloth dampened in a solution of warm water and mild liquid dishwashing detergent. Rinse thoroughly and wipe dry.
- Never use harsh cleaners, wax or polish on the cabinet front.
- Be sure to wring excess water from the cloth before wiping around the controls. Excess water in or around the controls may cause damage to the air conditioner.
- Plug in air conditioner.

### Winter Storage

If you plan to store the air conditioner during the winter, remove it carefully from the window according to the installation instructions. Cover it with plastic or return it to the original carton.

# TROUBLESHOOTING TIPS

Before calling for service, review this list. It may save your time and expense. This list includes common occurrences that are not the result of defective workman-ship or materials in this appliance.

Problem	Solution
<b>Air conditioner does not start</b>	Wall plug disconnected. Push plug firmly into wall outlet.
	House fuse blown or circuit breaker tripped. Replace fuse with time delay type or reset circuit breaker.
	Plug Current Device Tripped. Press the RESET button.
	Power is OFF. Turn power ON.
<b>Air from unit does not feel cold enough</b>	Room temperature below 62°F(17°C). Cooling may not occur until room temperature rises above 62°F(17°C).
	Temperature sensing behind air filter element touching cold coil. Keep it from the cold coil.
	Set to a Lower temperature.
	Compressor stopped when changing modes. Wait for 3 minutes after set to the COOL mode.
<b>Air conditioner cooling, but room is too warm- ice forming on cooling coil behind decorative front.</b>	Outdoor temperature below 64°F(18°C). To defrost the coil, set FAN ONLY mode.
	Air filter may be dirty. Clean filter. Refer to Care and Cleaning section. To defrost, set to FAN ONLY mode.
	Thermostat set too cold for night-time cooling. To defrost the coil, set to FAN ONLY mode. Then, set temperature to a Higher setting.
<b>Air conditioner cooling, but room is too warm- NO ice forming on cooling coil behind decorative front.</b>	Dirty air filter- air restricted. Clean air filter. Refer to Care and Cleaning section.
	Temperature is set too High, set temperature to a Lower setting.
	Air directional louvers positioned improperly. Position louvers for better air distribution.
	Front of units is blocked by drapes, blinds, furniture, etc. - restricts air distribution. Clear blockage in front of unit.
	An open doors, windows, or register may allow cold air to escape. Close any doors, windows, or registers.
	The room may be too warm. Allow additional time to remove "Stored heat" from walls, ceiling, floor and furniture.
<b>Air conditioner turns on and off rapidly</b>	Dirty air filter- air restricted. Clean air filter.
	Outside temperature extremely hot. Set FAN speed to a Higher setting to bring air past cooling coils more frequently.
<b>Noise when unit is cooling</b>	Air movement sound. This is normal . If too loud, set to a slower FAN setting.
	Window vibration - poor installation. Refer to installation instructions or check with installer.

Problem	Solution
<b>Water dripping INSIDE when unit is cooling.</b>	Improper installation. Tilt air conditioner slightly to the outside to allow water drainage. Refer to installation instructions - check with installer.
<b>Water dripping OUTSIDE when unit is cooling.</b>	Unit removing large quantity of moisture from humid room. This is normal during excessively humid days.
<b>Remote Sensing Deactivating Prematurely (some models)</b>	Remote control not located within range. Place remote control within 20 feet and pointed in the general direction of the air conditioner unit.
	Remote control signal obstructed. Remove obstruction.
<b>Room too cold</b>	Set temperature too low. Increase set temperature.

## Element Appliance Limited Warranty

(the “Products” or “Product” when referencing a singular product herein)

This Product (including any accessories included in the original packaging) as supplied and distributed in new condition, is warranted by Element Appliance Company, LLC (“Element”) to the original customer who purchases the Product from an authorized Element retailer (the “Original Customer” or “you”) against defects in material and workmanship under proper use, maintenance, and care according to the owner’s manual, warnings, and instructions accompanying the Product (“Warranty”) as follows:

\* **PLEASE NOTE** – Proof of purchase evidencing the date of purchase by the Original Purchaser from an authorized Element retailer (“Valid Proof of Purchase”) is **required** for all Warranty service. The express Warranty set forth herein is subject to all terms and conditions set forth below.

### 1. **WARRANTY SERVICE:**

**A. ONE-YEAR WARRANTY:** Except as provided in subpart 1.B below, for a period of **one (1) year** from the date of purchase by the Original Customer (the “Warranty Period”), if the parts or components covered by this Warranty are determined by Element or Element’s authorized service provider to be defective in material or workmanship, Element will, at its sole and absolute discretion and option: (i) repair the defective part or component at no charge to the Original Customer, (ii) replace the defective Product with a new Product of similar or better quality, at no charge to the Original Customer, or (iii) refund the documented purchase price paid by the Original Customer (excluding tax) to the Original Customer upon return of the defective Product as directed by Element. After the Warranty Period expires, the Original Customer must pay for all parts, components, shipping and handling, labor, and replacement costs associated with the Product or any part or component thereof, regardless of any defects in the Product or any part or component thereof.

**B. LIMITED EXTENDED WARRANTY THROUGH PRODUCT REGISTRATION:** If and only if the Original Customer registers the Product at [www.elementelectronics.com](http://www.elementelectronics.com) within **ninety (90)** days of the date of purchase by the Original Customer, then the Warranty Period discussed in subpart 1.A. above shall be extended an additional one (1) year to a new Warranty Period equaling **two (2) years** from the date of purchase by the Original Customer. If the Product is not registered as provided for in this subpart 1.B, then the standard one-year Warranty Period set forth in subpart 1.A shall apply.

**C. TIMING AND PROCEDURE:** Before Warranty service can commence, the Original Customer must contact either (i) the retailer from whom the Original Customer purchased the Product, or (ii) Element directly, in either case for problem determination and service procedures. Valid Proof of Purchase evidencing that the Product is within the Warranty Period **MUST** be presented by Original Customer in order to obtain the requested Warranty service. Please have your model and serial number available, along with your date of purchase of the Product. To remain eligible for Warranty service, Original Customer may not return the Product or any part or component thereof to the retailer or Element without Element’s prior written consent.

### 2. **EXCLUSIONS AND LIMITATIONS TO WARRANTY SERVICE**

The Warranty covers manufacturing defects in materials and workmanship of the Product encountered in the normal, non-commercial use of the Product, and **does not cover** (a) damages or malfunctions resulting from improper or unreasonable use or maintenance, abuse, negligence, failure to follow instructions contained in any written materials that accompany the Product, deterioration by reason of excess moisture, corrosive atmosphere, lightning, power surges, connections to improper voltage supply, unauthorized alteration, or other external causes such as extremes in temperature or humidity, modifications, scratches or discoloration; (b) improper or incorrectly performed repairs by service providers not authorized by Element; (c) transportation, shipping, delivery, pickup, insurance, installation, or set-up costs; (d) ordinary wear and tear, cosmetic damage, or damage due to acts of nature, including but not limited to,



water, floods, wind, storm, tornado, earthquake, or fire, or due to damage caused by extraordinary impact events, such as dropping, crushing, demolition or other extraordinary damage; (e) commercial use of the Product, or use of the Product for anything other than single-family household or residential use; or (f) modification of the Product or any part of the Product.

This Warranty is made to the Original Customer only and does not cover Products sold AS IS or WITH ALL FAULTS. The Warranty is invalid if the factory-applied serial number has been altered or removed from the Product. This Warranty is valid only in the United States, and only applies to Product if it was purchased and serviced in the United States. The addition of equipment or features to the Product that are not manufactured or recommended by Element could affect the intended function of the Product, and therefore may void the Warranty. Furthermore, the exposure of the Product to chemicals, heat, cold, humidity, or other elements can affect the Product components, and therefore, the Warranty does not cover discoloration, fading, cosmetic changes, rust, or any damages or failure related to any such items. The Warranty is contingent upon the proper use, maintenance, and care of the Product. The Warranty may be void if the Product has been used in a manner contradictory to, or in violation of, the terms of the user's manual, warnings, or instructions accompanying the Product.

**THIS WARRANTY IS MADE IN LIEU OF AND SUPERSEDES ALL OTHER WARRANTIES OR CONDITIONS OF MERCHANTABILITY OR FITNESS FOR A PARTICULAR PURPOSE OR GENERAL USE, WHETHER EXPRESS, IMPLIED, COLLATERAL, STATUTORY, OR PROVIDED BY COMMON LAW, THE UNIFORM COMMERCIAL CODE, OR OTHERWISE. ELEMENT FURTHER DISCLAIMS ALL WARRANTIES AFTER THE END OF THE WARRANTY TERM DEFINED ABOVE. NO OTHER EXPRESS WARRANTY OR GUARANTY GIVEN BY ANY OTHER PERSON, FIRM, OR ENTITY WITH RESPECT TO THE PRODUCT SHALL BE BINDING ON ELEMENT. REPAIR, REPLACEMENT, OR REFUND OF THE ORIGINAL PURCHASE PRICE, AT ELEMENT'S SOLE DISCRETION, ARE THE EXCLUSIVE REMEDIES OF THE CUSTOMER.**

**ELEMENT SHALL NOT BE LIABLE FOR ANY INCIDENTAL OR CONSEQUENTIAL DAMAGES CAUSED BY THE USE, MISUSE, OR INABILITY TO USE THE PRODUCT. THESE INCLUDE, BUT ARE NOT LIMITED TO, ANY DAMAGES IN THE FORM OF LOST PROFITS, LOSS OF USE, LEGAL FEES, ECONOMIC LOSS, PERSONAL INJURIES, OR ANY OTHER DAMAGES CAUSED BY CIRCUMSTANCES BEYOND THE CONTROL OF ELEMENT. NOTWITHSTANDING THE FOREGOING, ELEMENT'S AGGREGATE LIABILITY TO ANY CUSTOMER SHALL NOT EXCEED THE ORIGINAL PURCHASE PRICE OF THE PRODUCT. THIS WARRANTY SHALL NOT EXTEND TO ANYONE OTHER THAN THE ORIGINAL CUSTOMER WHO PURCHASED THE PRODUCT, AND IS NOT TRANSFERABLE. NO PERSON IS AUTHORIZED TO ALTER, EXTEND, OR WAIVE THIS WARRANTY OR ANY OF ITS TERMS OR CONDITIONS.**

Some states do not allow the exclusion or limitation of incidental or consequential damages, or allow limitations on warranties, so the above limitations or exclusions may not apply to you. This Warranty gives you specific rights, and you may have other rights, which vary from state to state. The exclusions and limitations to the Warranty apply to the maximum extent permitted by law and unless restricted or prohibited by law. Where any term of this Warranty is prohibited by applicable law, it shall be null and void, but the remainder of this Warranty shall remain in effect.

**PLEASE DIRECT ALL CORRESPONDENCE TO:**

Element Appliance Company, LLC  
[customerservice@elementelectronics.com](mailto:customerservice@elementelectronics.com)  
(888) 842-3577  
<https://elementelectronics.com>





Element, the Element Logo, and Bring it home are trademarks of Element Brand Holding, LLC. All other trademarks are the property of their respective owner, who has not sponsored, endorsed, or approved this product. ©2023 Element Appliance Company, LLC. All rights reserved.

Distributed by Element Appliance Company, LLC  
Augusta, GA 30909

For service, support and warranty information:  
Call 888.842.3577, email us at [customerservice@elementelectronics.com](mailto:customerservice@elementelectronics.com) or visit  
[www.elementelectronics.com](http://www.elementelectronics.com)

The design and specifications are subject to change without prior notice for product improvement. Consult with the sales agency or manufacturer for details. Any updates to the manual will be uploaded to the service website, please check for the latest version.

CWS002IU-TYN8(GF) COMP II

# **REMOTE CONTROL**

# **OWNER'S MANUAL**



EWR06BE  
EWR08BE  
EWR10BE  
EWR12BE  
EWR14B  
EWR18BE  
EWR25BE

## **IMPORTANT NOTE:**

Thank you for purchasing our air conditioner. Please read this manual carefully before operating your new air conditioning unit. Make sure to save this manual for future reference.

# Table of Contents

Remote Control Specifications .....	02
Handling the Remote Control .....	03
Buttons and Functions .....	04
Remote Screen Indicators .....	08
How to Use Basic Functions .....	09
How to Use Advanced Functions .....	12

# Remote Control Specifications

<b>Model</b>	RG51G(1)/CEFU1, RG51G(1)/EFU1, RG51G1(1)/EFU1, RG51G4(1)/EU1, RG51G5(1)/EU1, RG51G4(1)/CEU1, RG51G5(1)/CEU1
<b>Rated Voltage</b>	3.0V( Dry batteries R03/LR03×2)
<b>Signal Receiving Range</b>	8m
<b>Environment</b>	23°F~140°F (-5°C~60°C)

## Quick Start Guide

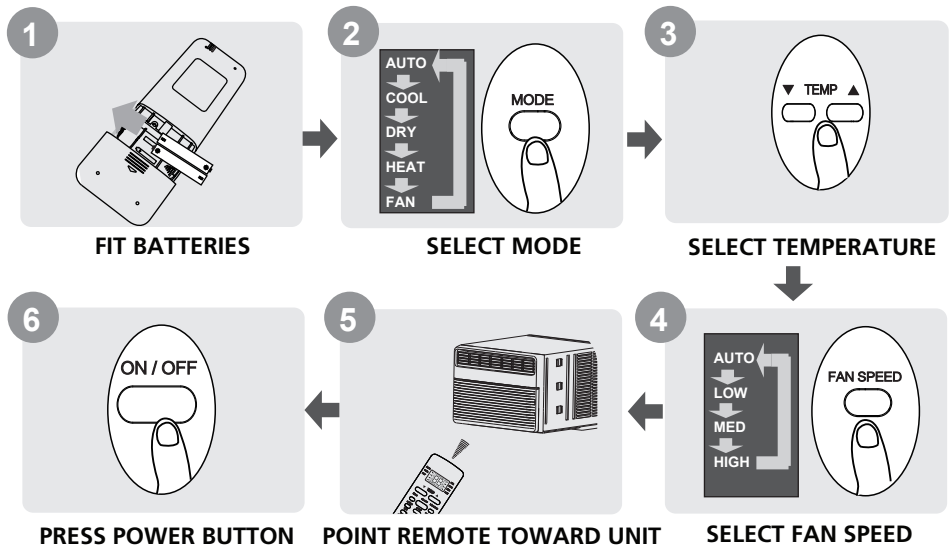

### NOT SURE WHAT A FUNCTION DOES?

Refer to the **How to Use Basic Functions** and **How to Use Advanced Functions** sections of this manual for a detailed description of how to use your air conditioner.

### SPECIAL NOTE

- Button designs on your unit may differ slightly from the example shown.
- If the indoor unit does not have a particular function, pressing that function's button on the remote control will have no effect.
- When there are wide differences between "Remote control Manual" and "USER'S MANUAL" on function description, the description of "USER'S MANUAL" shall prevail.

# Handling the Remote Control

## Inserting and Replacing Batteries

Your air conditioning unit may come with two batteries (some units). Put the batteries in the remote control before use.

1. Slide the back cover from the remote control downward, exposing the battery compartment.
2. Insert the batteries, paying attention to match up the (+) and (-) ends of the batteries with the symbols inside the battery compartment.
3. Slide the battery cover back into place.

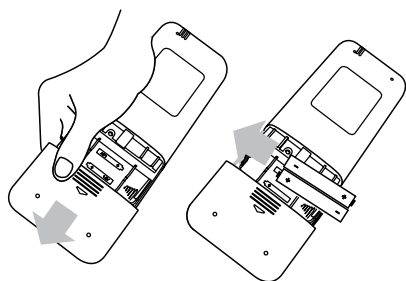

## NOTES FOR USING REMOTE CONTROL

The device could comply with the local national regulations.

- In Canada, it should comply with CAN ICES-3(B)/NMB-3(B).
- In USA, this device complies with part 15 of the FCC Rules. Operation is subject to the following two conditions:
  - (1) This device may not cause harmful interference, and
  - (2) this device must accept any interference received, including interference that may cause undesired operation.

This equipment has been tested and found to comply with the limits for a Class B digital device, pursuant to part 15 of the FCC Rules. These limits are designed to provide reasonable protection against harmful interference in a residential installation. This equipment generates, uses and can radiate radio frequency energy and, if not installed and used in accordance with the instructions, may cause harmful interference to radio communications. However, there is no guarantee that interference will not occur in a particular installation. If this equipment does cause harmful interference to radio or television reception, which can be determined by turning the equipment off and on, the user is encouraged to try to correct the interference by one or more of the following measures:

- Reorient or relocate the receiving antenna. Increase the separation between the equipment and receiver.
- Connect the equipment into an outlet on a circuit different from that to which the receiver is connected.
- Consult the dealer or an experienced radio/TV technician for help.
- Changes or modifications not approved by the party responsible for compliance could void user's authority to operate the equipment.

## ! BATTERY NOTES

For optimum product performance:

- Do not mix old and new batteries, or batteries of different types.
- Do not leave batteries in the remote control if you don't plan on using the device for more than 2 months.



## BATTERY DISPOSAL

Do not dispose of batteries as unsorted municipal waste. Refer to local laws for proper disposal of batteries.

## TIPS FOR USING REMOTE CONTROL

- The remote control must be used within 8 meters of the unit.
- The unit will beep when remote signal is received.
- Curtains, other materials and direct sunlight can interfere with the infrared signal receiver.
- Remove batteries if the remote will not be used more than 2 months.

## Buttons and Functions

Before you begin using your new air conditioner, make sure to familiarize yourself with its remote control. The following is a brief introduction to the remote control itself. For instructions on how to operate your air conditioner, refer to the How to Use Basic Functions section of this manual.

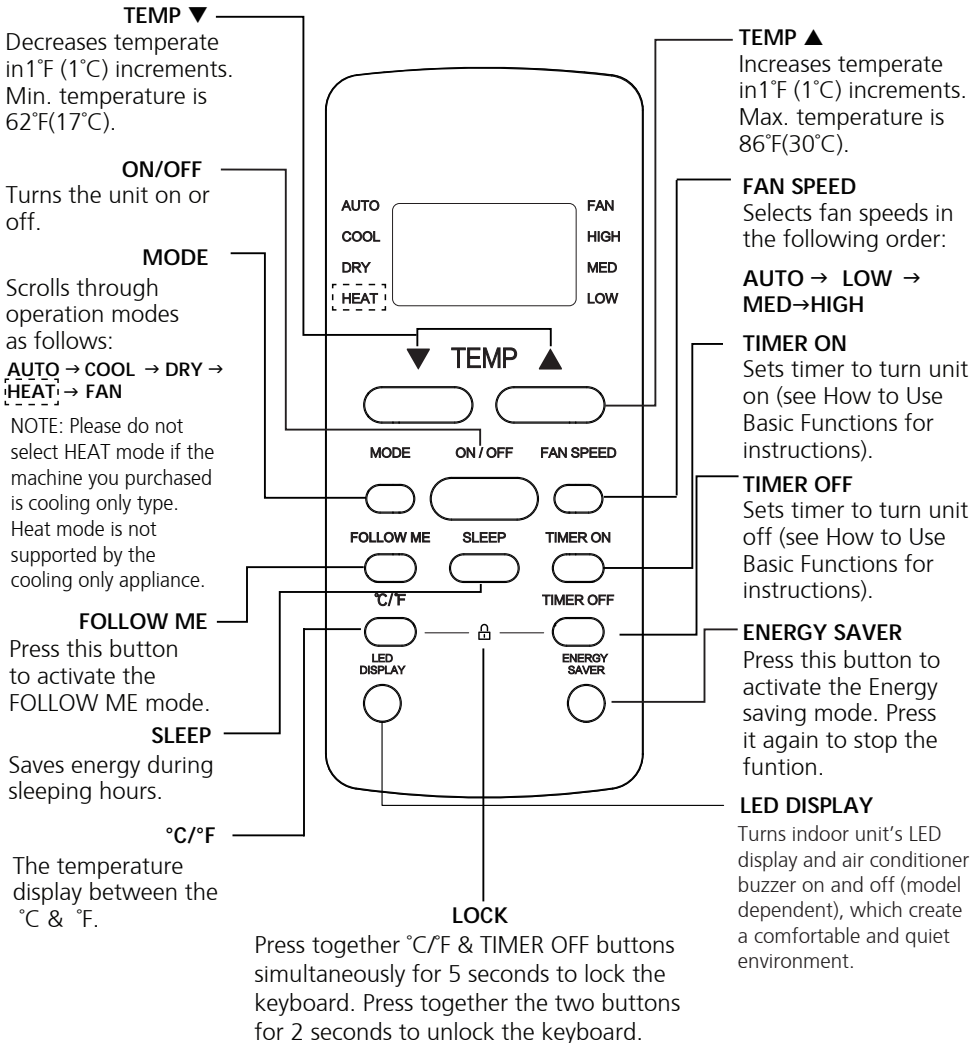

Model: RG51G(1)/CEFU1  
RG51G(1)/EFU1

NOTE: Model RG51G(1)/CEFU1 does not have HEAT feature.

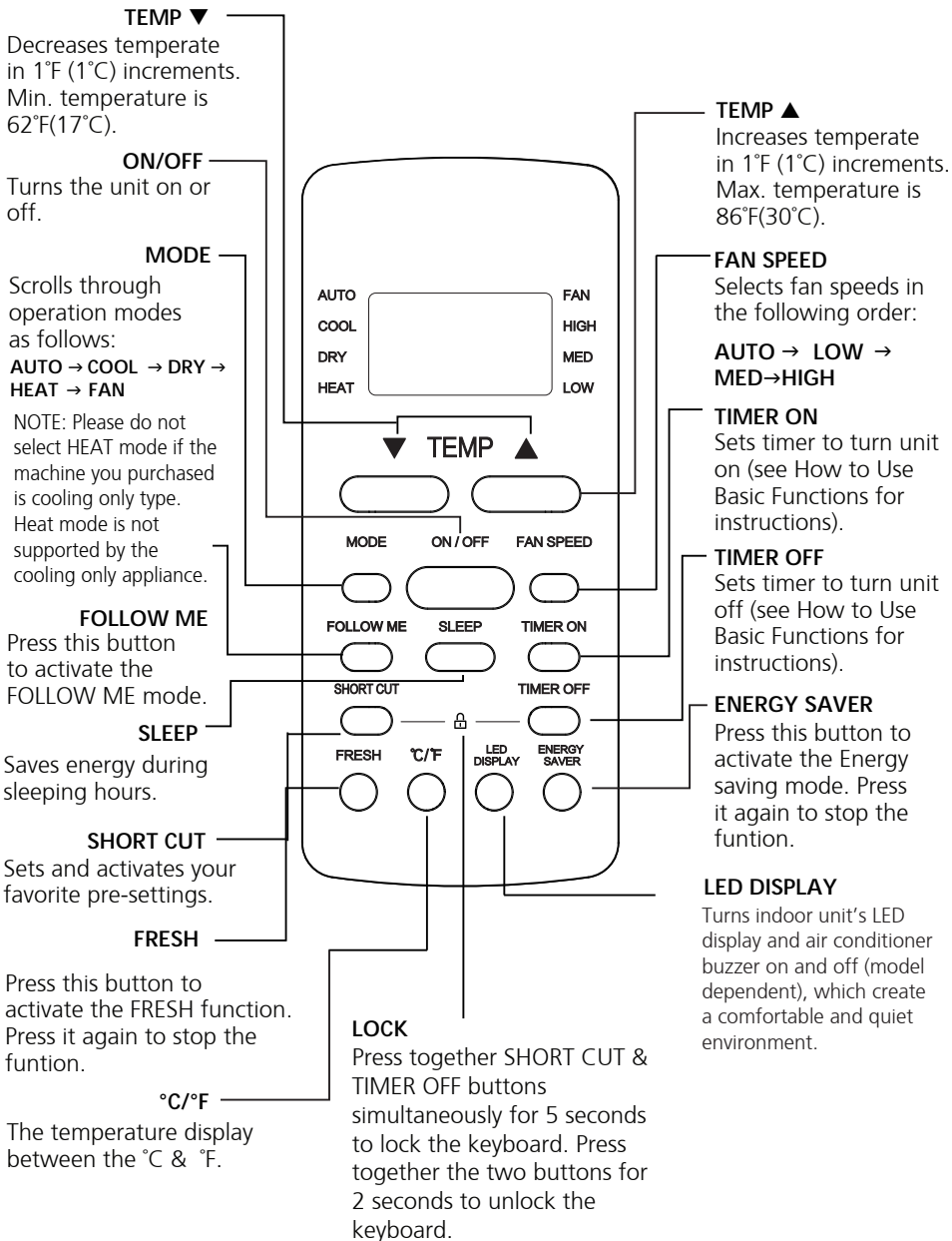

RG51G1(1)/EFU1

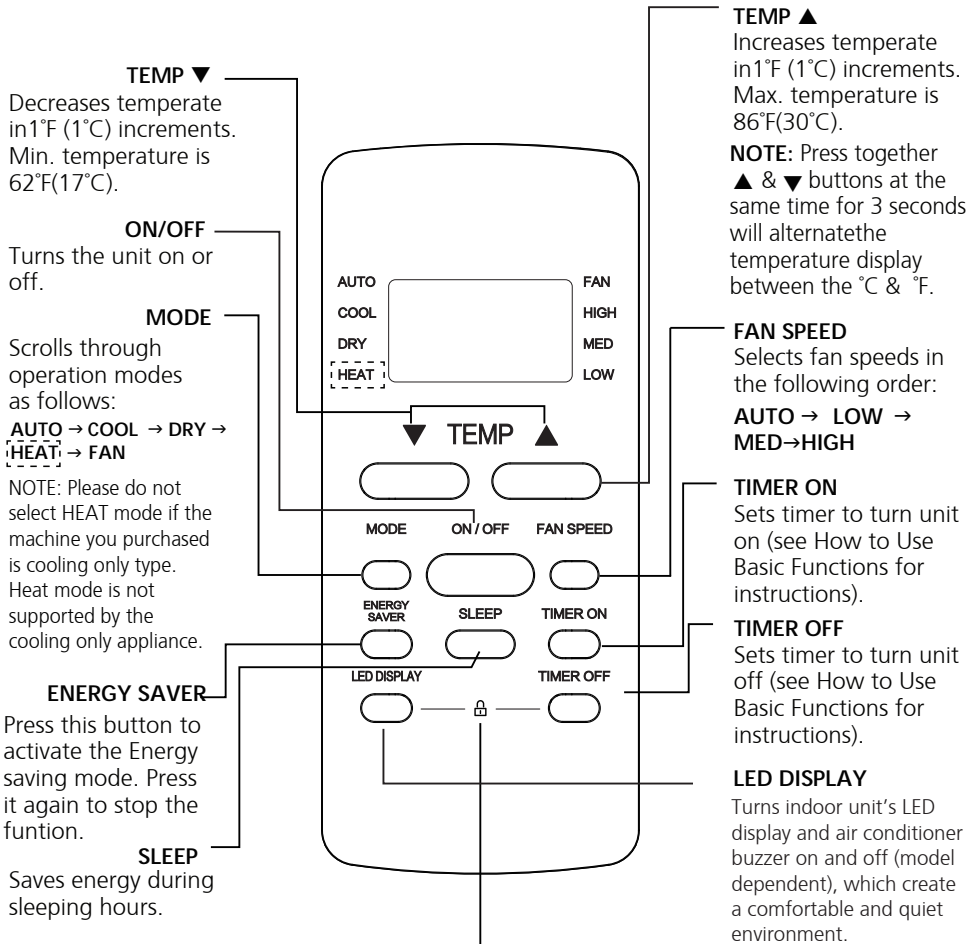

**LOCK**

Press together LED DISPLAY & TIMER OFF buttons simultaneously for 5 seconds to lock the keyboard. Press together the two buttons for 2 seconds to unlock the keyboard.

Model: RG51G4(1)/CEU1  
RG51G4(1)/EU1

**NOTE:** Model RG51G4(1)/CEU1 does not have HEAT feature.



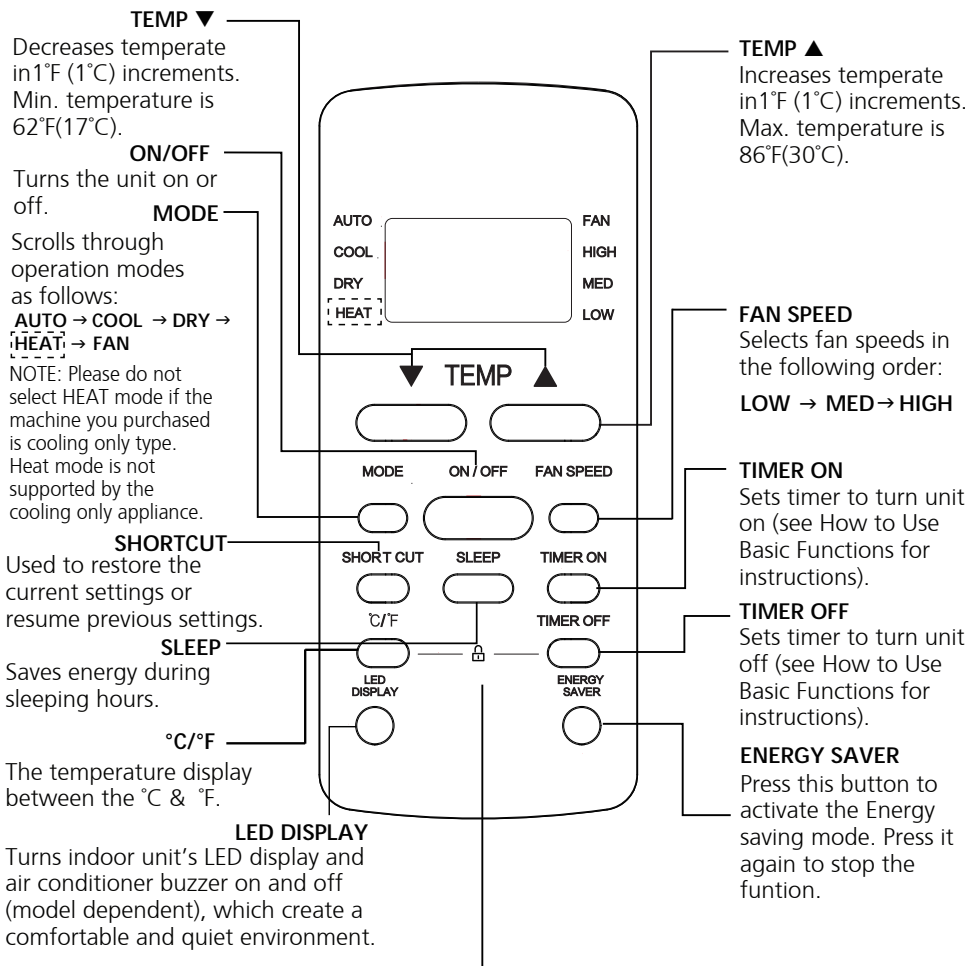

### LOCK

Press together °C/°F & TIMER OFF buttons simultaneously for 5 seconds to lock the keyboard. Press together the two buttons for 2 seconds to unlock the keyboard.

RG51G5(1)/EU1  
RG51G5(1)/CEU1

**NOTE:** Model RG51G5(1)/CEU1 does not have HEAT feature.

## Remote Screen Indicators

Information are displayed when the remote control is power up.

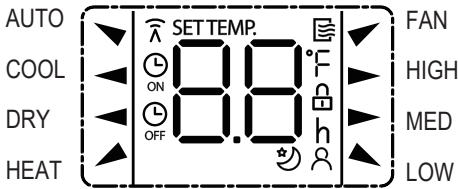

### Mode display

AUTO ▼ COOL ◀ DRY ◀  
HEAT ▲ ▼ FAN

Displayed when data transmitted.  
 Displayed when remote controller is ON.

Displayed when TIMER ON time is set

Displayed when TIMER OFF time is set

Shows set temperature or room temperature, or time under TIMER setting

Indicated all the current settings are locked

Displayed when Follow Me feature is activated(some units)

Displayed when SLEEP feature is activated

### Fan speed indication

▶ HIGH High speed  
▶ MED Medium speed  
▲ LOW Low speed  
NO display Auto fan speed

#### Note:

All indicators shown in the figure are for the purpose of clear presentation. But during the actual operation, only the relative function signs are shown on the display window.

# How to Use Basic Functions

## Basic operation

**ATTENTION!** Before operation, please ensure the unit is plugged in and power is available.

## COOL Mode

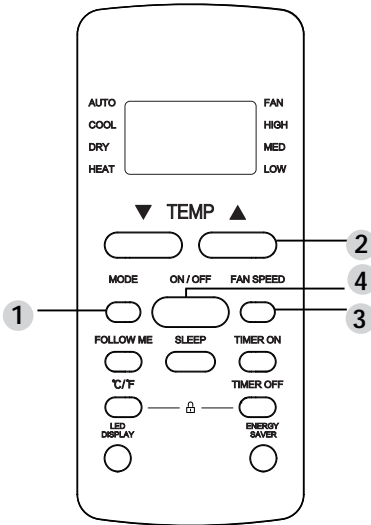

1. Press the **MODE** button to select **COOL** mode.
2. Set your desired temperature using the **TEMP ▲** or **TEMP ▼** button.
3. Press **FAN** button to select the fan speed: AUTO, LOW, MED or HIGH.
4. Press the **ON/OFF** button to start the unit.

## SETTING TEMPERATURE

The operating temperature range for units is 62-86°F(17-30°C ). You can increase or decrease the set temperature 1 °F(1°C) increments.

## AUTO Mode

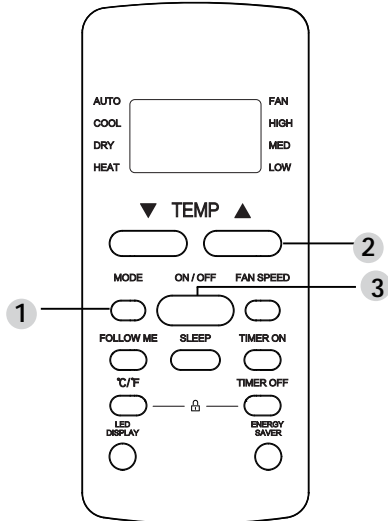

In AUTO mode, the unit will automatically select the COOL, FAN, or HEAT operation based on the set temperature.

1. Press the **MODE** button to select **AUTO**.
2. Set your desired temperature using the **TEMP ▲** or **TEMP ▼** button.
3. Press the **ON/OFF** button to start the unit.

**NOTE:** FAN SPEED can't be set in AUTO mode.

In AUTO mode, the unit will automatically select the COOL, FAN, HEAT or DRY function based on the set temperature.

1. Press the **MODE** button to select **AUTO**.
2. Set your desired temperature using the **TEMP ▲** or **TEMP ▼** button.
3. Press the **ON/OFF** button to start the unit.

**NOTE:** FAN SPEED can't be set in AUTO mode.

## FAN Mode

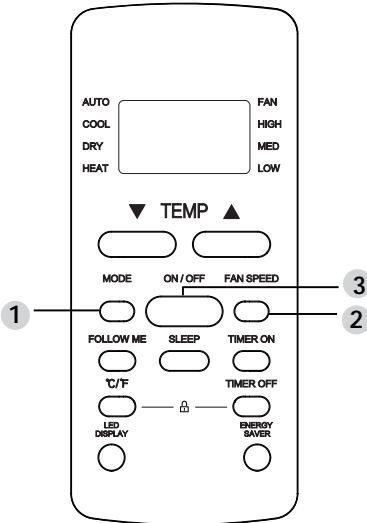

1. Press the **MODE** button to select **FAN** mode.
2. Press **FAN** button to select the fan speed: AUTO, LOW, MED or HIGH.
3. Press the **ON/OFF** button to start the unit.

**NOTE:** You can't set temperature in FAN mode. As a result, your remote control's LCD screen will not display temperature.

1. Press the **MODE** button to select **DRY**.
2. Set your desired temperature using the **TEMP ▲** or **TEMP ▼** button.
3. Press the **ON/OFF** button to start the unit.

**NOTE:** FAN SPEED cannot be changed in DRY mode.

## HEAT Mode (some models)

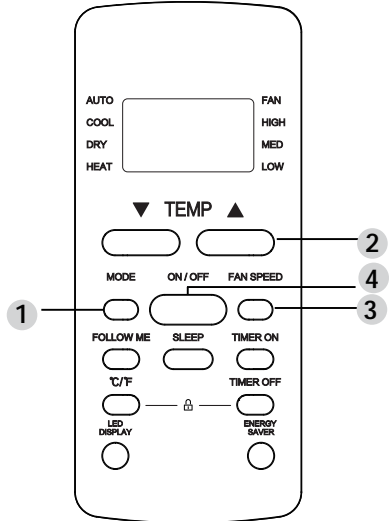

1. Press the **MODE** button to select **HEAT** mode.
2. Set your desired temperature using the **TEMP ▲** or **TEMP ▼** button.
3. Press **FAN** button to select the fan speed: AUTO, LOW, MED or HIGH.
4. Press the **ON/OFF** button to start the unit.

**NOTE:** As outdoor temperature drops, the performance of your unit's HEAT function may be affected. In such instances, we recommend using this air conditioner in conjunction with other heating appliances.

## DRY Mode (dehumidifying)

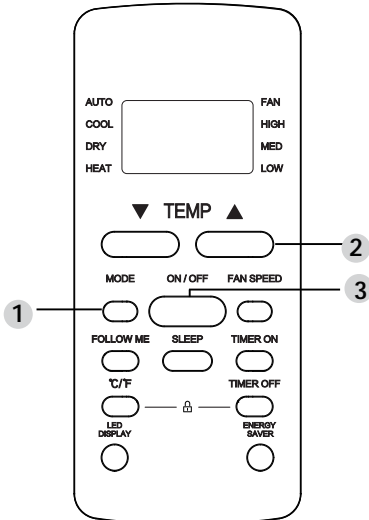

## Setting the TIMER

**TIMER ON/OFF** - Set the amount of time after which the unit will automatically turn on/off.

### TIMER ON setting

Press TIMER ON button to initiate the ON time sequence.

Press Temp. up or down button for multiple times to set the desired time to turn on the unit.

Point remote to unit and wait 1sec, the TIMER ON will be activated.

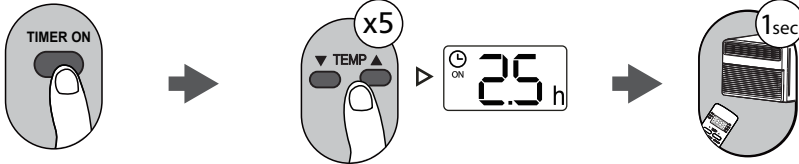

### TIMER OFF setting

Press TIMER OFF button to initiate the OFF time sequence.

Press Temp. up or down button for multiple times to set the desired time to turn off the unit.

Point remote to unit and wait 1sec, the TIMER OFF will be activated.

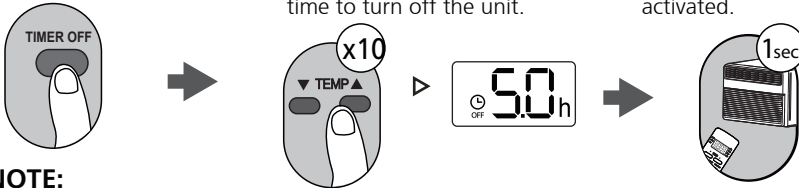

### NOTE:

1. When setting the TIMER ON or TIMER OFF, the time will increase by 30 minutes increments with each press, up to 10 hours. After 10 hours and up to 24, it will increase in 1 hour increments. (For example, press 5 times to get 2.5h, and press 10 times to get 5h,) The timer will revert to 0.0 after 24.
2. Cancel either function by setting its timer to 0.0h.

### TIMER ON & OFF setting(example)

Keep in mind that the time periods you set for both functions refer to hours after the current time.

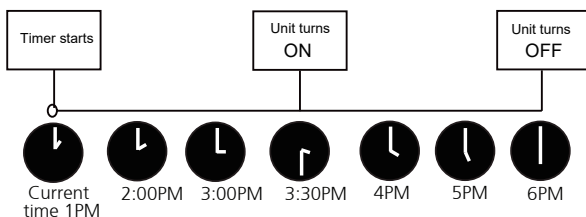
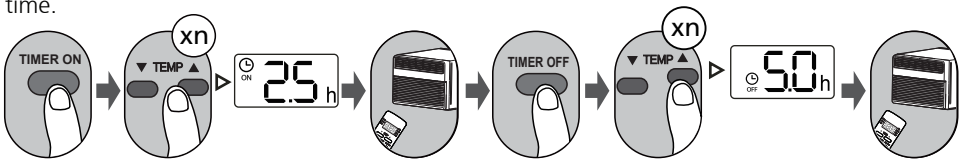

Example: If current timer is 1:00PM, to set the timer as above steps, the unit will turn on 2.5h later (3:30PM) and turn off at 6:00PM.

# How to Use Advanced Functions

## FOLLOW ME (some models)

Press FOLLOW ME button



When the FOLLOW ME function is activated, the remote display is actual temperature at its location. The remote control will send this signal to the air conditioner every 3 minutes interval until press the FOLLOW ME button again.

## ENERGY SAVER function (some models)



Press Energy saver button to initiate this function.

This function is available on COOL, DRY, AUTO (only AUTO-COOLING and AUTO-FAN) modes.

## °C/°F (some models)



Press this button will alternate the temperature display between the °C & °F.

## LED DISPLAY

Press LED button

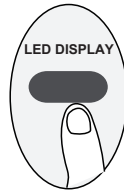

Press this button to turn on and turn off the display on the indoor unit.

## FRESH (some models)



When the FRESH function is initiated, the Ionizer/Plasma Dust Collector (depending on models) is energized and will help to remove pollen and impurities from the air.

## SHORTCUT function(some models)



Used to restore the current settings or resume previous settings.(For some models)

Push this button when remote controller is on, the system will automatically revert back to the previous settings including operating mode, setting temperature, fan speed level and sleep feature(if activated).

If pushing more than 2 seconds, the system will automatically restore the current operation settings including operating mode, setting temperature, fan speed level and sleep feature (if activated ).

## SLEEP function



The SLEEP function is used to decrease energy use while you sleep (and don't need the same temperature settings to stay comfortable). This function can only be activated via remote control.

The sleep function is not available in Fan or Dry mode.Please refer to the OWNER'S MANUAL for more details.

## APPENDIX A

### EXAMPLE OF SUPPLIER'S DECLARATION OF CONFORMITY COMPLIANCE INFORMATION STATEMENT INCLUDED WITH AN END PRODUCT AT THE TIME OF MARKETING OR IMPORTATION<sup>22</sup>

*NOTE: The Commission does not have a required SDoC format. This is an example only and is provided to illustrate the type of information that may be supplied with the product at the time of marketing or importation for meeting the FCC SDoC requirement Section 2.1077 compliance information.*

**Supplier's Declaration of Conformity  
47 CFR § 2.1077 Compliance Information**

**Unique Identifier:** RG51G(1)/CEFU1,RG51G5(1)/CEU1

**Responsible Party – U.S. Contact Information**

Element Appliance Company, LLC

jay.p@elementelectronics.com

**FCC Compliance Statement** (e.g., products subject to Part 15)

This device complies with Part 15 of the FCC Rules. Operation is subject to the following two conditions: (1) This device may not cause harmful interference, and (2) this device must accept any interference received, including interference that may cause undesired operation.

---

<sup>22</sup> See 47 CFR § 2.1077.

The design and specifications are subject to change without prior notice for product improvement. Consult with the sales agency or manufacturer for details.

**CR252-RG51G(1)B**