

Save This Manual
For Future Reference

SEARS

owner's
manual

Model No.

113.226880

113.298090

Saw With Legs And
Two Table Extensions

Serial
Number _____

Model and serial numbers
may be found at the rear of
the base.

You should record both model
and serial number in a safe
place for future use.

FOR YOUR SAFETY

READ ALL
INSTRUCTIONS
CAREFULLY

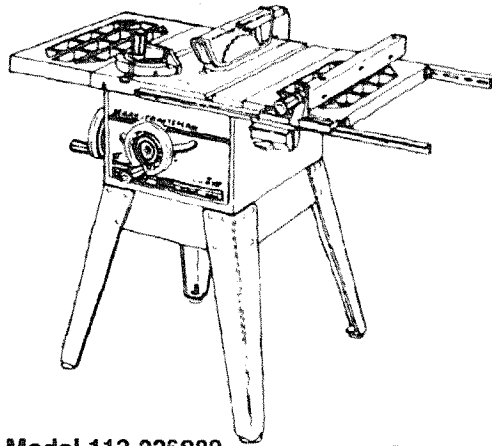

Model 113.226880

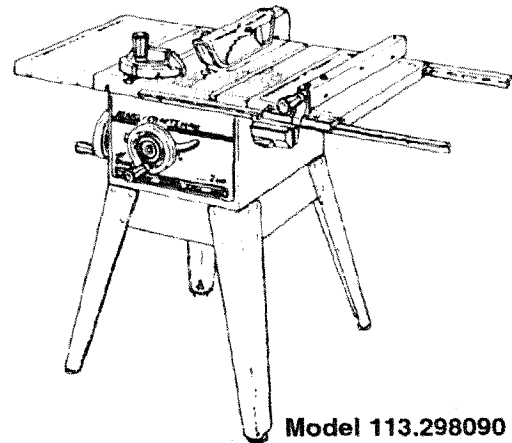

Model 113.298090

SEARS / CRAFTSMAN

10 INCH DIRECT DRIVE TABLE SAW

- assembly
- operating
- repair parts

Sears, Roebuck and Co., Hoffman Estates, IL. 60179 U.S.A.

FULL ONE YEAR WARRANTY ON CRAFTSMAN STATIONARY TOOLS

If, this stationary tool fails due to a defect in material or workmanship within one year from the date of purchase, CONTACT THE NEAREST SEARS SERVICE CENTER IN THE UNITED STATES and Sears will repair it, free of charge. This warranty applies only while this product is in the United States.

If this table saw is used for commercial or rental purposes, this warranty will apply for ninety days from the date of purchase.

This warranty gives you specific legal rights, and you may also have other rights which vary from state to state.

Sears, Roebuck and Co., D817 WA, Hoffman Estates, IL. 60179

SAFETY INSTRUCTIONS FOR TABLE SAW

Safety is a combination of common sense, staying alert and knowing how your table saw works. Read this manual to understand this saw.

BEFORE USING THE SAW

WARNING: To avoid mistakes that could cause serious, permanent injury, do not plug the saw in until the following steps have been satisfactorily completed.

1. Assembly and Alignment. (See pages 12-31)
2. Learn the use and function of the ON-OFF Switch, Guard, Spreader, Anti-Kickback device, Miter Gauge, Fence, Table Insert and Blade Elevation and Bevel Controls. (See pages 32-34)
3. Review and understanding of all safety instructions and operating procedures in this manual.
4. Review of the maintenance methods for this saw. (See page 46)

Read the DANGER label found on the front of the saw, as shown below.

WHEN INSTALLING OR MOVING THE SAW

1. AVOID DANGEROUS EQUIPMENT. Use the saw in a dry place protected from rain. Keep work area well lighted.
2. To avoid injury from unexpected saw movement:
 - A. Put the saw on a firm level surface where there is plenty of room for handling and properly supporting the workpiece.
 - B. Support the saw so that the table is level and the saw does not rock.
 - C. Bolt the saw to the floor if it tends to slip, walk or slide during normal use.
 - D. When using table extensions over 24 inches wide on any side of the saw, bolt the saw to the floor or prop up the outer end of the extension from the floor to keep the saw from tipping.
3. Put the saw where neither operator nor bystanders must stand in line with the saw blade.

4. GROUND THE SAW- This saw has an approved 3-conductor cord and a 3-prong grounding type plug. The plug fits grounding type outlets designed for 120 volt 15 amp circuits. The green conductor in the cord is the NEVER connect the green wire to a live terminal.
5. To avoid injury from electrical shock, make sure your fingers do not touch the plug's metal prongs when plugging in or unplugging the saw.
6. To avoid back injury, get help or use recommended casters when you need to move the saw. Always get help if you need to lift the saw. Hold the saw close to your body. Bend your knees so you can lift with your legs, not your back.
7. NEVER STAND ON TOOL. Serious injury could occur if the tool tips or you accidentally hit the cutting tool. Do not store anything above or near the tool where anyone might stand on the tool to reach them.

BEFORE EACH USE:

1. Inspect your saw

- A. To avoid injury from accidental starting, unplug the saw, turn the switch off and remove the switch key before raising or removing the Guard, changing the cutting tool, changing the setup or adjusting anything.
- B. Check for alignment of moving parts, binding of moving parts, breakage of parts, saw stability, and any other conditions that may affect the way the saw works. If any part is missing, bent or broken in any way, or any electrical part does not work properly, turn the saw off and unplug the saw.
- C. Replace damaged, missing or failed parts before using the saw again.
- D. Use the Sawblade Guard, Spreader and Anti-Kickback Pawls for any thru-sawing (whenever the blade comes through the top of the workpiece). Make sure the Pawls work properly. Make sure the Spreader is in line with sawblade.
- E. REMOVE ADJUSTING KEYS AND WRENCHES. Form habit of checking for and removing keys and adjusting wrenches from tool before turning it on.

▲ DANGER

- | | | | | |
|--|---|--|---|--|
| 1. Read manual before using saw. | 4. Keep blade guard down and in place for through cuts. | 7. When ripping, use push stick when fence is set 2 inches or more from blade. | 9. When ripping, use push block and auxiliary fence when fence is set between 1/2 and 2 inches from blade. Do not make rip cuts narrower than 1/2 inch. | 10. Turn power off and wait for blade to stop before adjusting or servicing. |
| 2. Wear safety goggles that meet ANSI Z87.1 standards. | 5. Do not do freehand cuts. | 8. Know how to reduce the risk of kickback. See instructions for ripping. | | |
| 3. Do not reach around or over saw blades. | 6. Keep hands out of path of saw blade. | | | |

F. To avoid injury from jams, slips or thrown pieces (kickback and throwback):

1. USE ONLY "RECOMMENDED ACCESSORIES" (See page 47). Follow the instructions that come with the accessories. Using other accessories may be dangerous.
2. Choose the right blade or cutting accessory for the material and the type of cutting you plan to do.
3. Never use grinding wheels, abrasive cut-off wheels, friction wheels (metal slitting blades) wire wheels or buffing wheels. They can fly apart explosively.
4. Choose and inspect your cutting tool carefully.
 - a. To avoid cutting tool failure and thrown shrapnel (broken pieces of blade), use only 10" or smaller blades or other cutting tools marked for speeds of 3450 rpm or higher.
 - b. Always use unbroken, balanced blades designed to fit this saw's 5/8 inch arbor.
 - c. When thru-sawing (making cuts where the blade comes through the workpiece top), always use a 10 inch diameter blade. This keeps the spreader in closest to the blade.
 - d. Do not over tighten arbor nut. Use arbor wrenches to "snug" it securely.
 - e. Use only sharp blades with properly set teeth. Consult a professional blade sharpener when in doubt.
 - f. Keep blades clean of gum and resin.
5. Adjust table inserts flush with the table top. NEVER use the saw without the proper insert.
6. Make sure all clamps and locks are tight and no parts have any excessive play.

2. Keep work area clean

- A. Cluttered areas and benches invite accidents. Floor must not be slippery from wax or sawdust.
- B. To avoid burns or other fire damage, never use the saw near flammable liquids, vapors or gases.

3. Plan your work - plan ahead to protect your eyes, hands, face, ears.

WARNING: To avoid injury, don't do layout, assembly, or setup work on the table while the blade is spinning. It could cut or throw anything hitting the blade.

- A. USE THE RIGHT TOOL - Don't force tool or attachment to do a job it was not designed for.
- B. Dress for safety:
 1. Do not wear loose clothing, gloves, neckties or jewelry (rings, wristwatches). They can get caught and draw you into moving parts.
 2. Wear non-slip footwear.
 3. Tie back long hair.

4. Roll long sleeves above the elbow.
5. Noise levels vary widely. To avoid possible hearing damage, wear ear plugs or muffs when using saw for long periods of time.
6. Any power saw can throw foreign objects into the eyes. This can cause permanent eye damage. Wear safety **goggles (not glasses)** that comply with ANSI Z87.1 (shown on package). Everyday eyeglasses have only impact resistant lenses. They are not safety glasses. Safety goggles are available at Sears retail catalog stores. Glasses or goggles not in compliance with ANSI Z87.1 could seriously hurt you when they break.



7. For dusty operations, wear a dust mask along with the safety goggles.
- C. Inspect your workpiece. Make sure there are no nails or foreign objects in the part of the workpiece to be cut.
- D. Plan your cut to avoid **KICKBACKS** and **THROWBACKS** - when a part or all of the workpiece binds on the blade and is thrown violently back toward the front of the saw.
1. **Never cut FREEHAND:** Always use either a Rip Fence, Miter Gauge or fixture to position and guide the work, so it won't twist, bind on the blade and kickback.
 2. Make sure there's no debris between the workpiece and its supports.
 3. When cutting **irregularly shaped workpieces**, plan your work so it will not slip and pinch the blade:
 - a. A piece of molding, for example, must lie flat or be held by a fixture or jig that will not let it twist, rock or slip while being cut. Use jigs or fixtures where needed to prevent workpiece shifting.
 - b. Use a different, better suited type of tool for work that can't be made stable.
 4. Use extra caution with large, very small or awkward workpieces:
 - a. Use extra supports (tables, saw horses, blocks, etc.) for any workpieces large enough to tip when not held down to the table top. **NEVER use another person** as a substitute for a table extension, or as additional support for a workpiece that is longer or wider than the basic saw table, or to help feed, support or pull the workpiece.

safety instructions for table saw

- b. Never confine the piece being cut off, that is, the piece NOT against the fence, miter gauge or fixture. Never hold it, clamp it, touch it, or use length stops against it. It must be free to move. If confined, it could get wedged against the blade and cause a kickback or throwback.
- c. Never cut more than one workpiece at a time.
- d. Never turn your table saw "ON" before clearing everything except the workpiece and related support devices off the table.

4. Plan the way you will push the workpiece through

- A. **NEVER pull the workpiece through.** Start and finish the cut from the front of the table saw.
- B. **NEVER put your fingers or hands in the path of the sawblade or other cutting tool.**
- C. **NEVER reach in back** of the cutting tool with either hand to hold down or support the workpiece, remove wood scraps, or for any other reason.
- D. Avoid hand positions where a sudden slip could cause fingers or hand to move into a sawblade or other cutting tool.
- E. **DON'T OVERREACH.** Always keep good footing and balance.
- F. Push the workpiece against the rotation of the blade. **NEVER** feed material into the cutting tool from the rear of the saw.
- G. Always push the workpiece all the way past the sawblade.
- H. As much as possible, keep your face and body to one side of the sawblade, out of line with a possible kickback or throwback.
- I. **NEVER** turn the saw "ON" before clearing the table of all tools, wood scraps, etc., except the workpiece and related feed or support devices for the cut planned.
- J. **AVOID ACCIDENTAL STARTING** - Make sure switch is "OFF" before plugging saw in.

WHENEVER SAW BLADE IS SPINNING

WARNING: Don't let familiarity (gained from frequent use of your table saw) cause a careless mistake. Always remember that a careless fraction of a second is enough to cause a severe injury.

- 1. Before actually cutting with the saw, watch it while it runs for a short while. If it makes an unfamiliar noise or vibrates a lot, stop immediately. Turn the saw off. Unplug the saw. Do not restart until finding and fixing the problem.
- 2. Make sure the top of the arbor or cutting tool turns toward the front of the saw.
- 3. Set the cutting tool as low as possible for the cut you're planning.

- 4. **KEEP CHILDREN AWAY.** All visitors should be kept a safe distance from work. Make sure bystanders are clear of the saw and workpiece.
- 5. Let the blade reach full speed before cutting.
- 6. **DON'T FORCE TOOL.** It will do the job better and safer at its designed rate. Feed the workpiece into the blade only fast enough to let it cut without bogging down or binding.
- 7. Before freeing any jammed material:
 - A. Turn switch "OFF".
 - B. Unplug the saw.
 - C. Wait for all moving parts to stop.
 - D. Check blade, Spreader and Fence for proper alignment before starting, again.
- 8. To avoid throwback of cut off pieces;
 - A. Use the Guard assembly.
 - B. To remove loose pieces beneath or trapped inside the guard:
 - 1. Turn saw "OFF".
 - 2. Remove switch key.
 - 3. Wait for blade to stop before lifting the Guard.

ADDITIONAL INSTRUCTIONS FOR RIP TYPE CUTS

- 1. **NEVER** use the Miter Gauge when ripping.
- 2. Use a Push Stick whenever the fence is 2 or more inches from the blade. When thru-sawing, use an Auxiliary Fence and Push Block whenever the Fence must be between 1/2 and 2 inches of the blade. Never thru-saw rip cuts narrower than 1/2 inch. (See "BASIC SAW OPERATION - USING THE RIP FENCE" section.)
- 3. Never rip anything shorter than 10" long.
- 4. When using a Push Stick or Push Block, the trailing end of the board must be square. A Push Stick or Block against an uneven end could slip off or push the work away from the Fence.
- 5. A **FEATHERBOARD** can help guide the workpiece. (See "BASIC SAW OPERATION - USING THE RIP FENCE.") **Always** use Featherboards for any non thru rip type cuts.

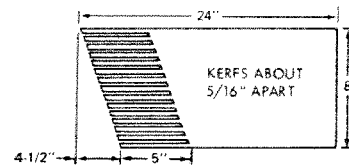

BEFORE STARTING

- 1. To avoid kickbacks and slips into the blade, make sure the Rip Fence is parallel to the sawblade.

2. Before thru-sawing, check the Anti-Kickback Pawls. (See "BASIC SAW OPERATION - USING THE RIP FENCE.") The Pawls must stop a kickback once it has started. Replace or sharpen Anti-Kickback Pawls when points become dull.
3. Plastic and composition (like hardboard) materials may be cut on your saw. However, since these are usually quite hard and slippery, the Anti-Kickback Pawls may not stop a kickback. Therefore, be especially careful in your set-up and cutting procedures.

WHILE CUTTING

1. To avoid kickbacks and slips into the blade, always push forward on the section of the workpiece between the saw blade and the Rip Fence. Never push forward on the piece being cut off.

ADDITIONAL INSTRUCTIONS FOR CROSS CUT TYPE CUTS

BEFORE STARTING

1. NEVER use the Rip Fence when crosscutting.
2. An auxiliary wood facing attached to the Miter Gauge can help prevent workpiece twisting and throwbacks.

Attach it to the holes provided. Make the facing long enough and big enough to support your work. Make sure, however, it will not interfere with the Sawblade Guard.

3. Use jigs or fixtures to help hold any piece too small to extend across the full length of the Miter Gauge face during the cut. This lets you properly hold the Miter Gauge and workpiece and helps keep your hands away from the blade. (See page 32.)

WHILE CUTTING

1. To avoid blade contact, always hold the Miter Gauge as shown in "BASIC SAW OPERATIONS - USING THE MITER GAUGE."

BEFORE LEAVING THE SAW

1. Turn the saw off.
2. Wait for blade to stop spinning.
3. Make workshop child-proof. Lock the shop. Disconnect master switches. Remove the yellow Switch Key. Store it away from children and others not qualified to use the tool.
4. Unplug the saw.

glossary of terms for woodworking

Anti-Kickback Pawls (AKP)

Device which, when properly maintained, is designed to stop the workpiece from being kicked back at the operator during ripping operation.

Arbor

The shaft on which a cutting tool is mounted.

Crosscut

A cutting or shaping operation made across the width of the workpiece.

Dado

A non through cut which produces a square sided notch or trough in the workpiece.

Featherboard

A device which can help guide workpieces during rip type operation.

Freehand

Performing a cut without using a Fence, Miter Gauge, fixture, hold down or other proper device to keep the workpiece from twisting during the cut.

Gum

A sticky, sap based residue from wood products.

Heel

Misalignment of the blade.

Kerf

The amount of material removed by the blade in a through cut or the slot produced by the blade in a non through or partial cut.

Kickback

An uncontrolled grabbing and throwing of the workpiece back toward the front of the saw.

Leading End

The end of the workpiece which, during a rip type operation, is pushed into the cutting tool first.

Molding

A non through cut which produces a special shape in the workpiece used for joining or decoration.

Push Stick

A device used to feed the workpiece through the saw during narrow ripping type operations and helps keep the operator's hands well away from the blade.

Push Block

A device used for ripping type operations too narrow to allow use of a Push Stick.

Rabbet

A notch in the edge of a workpiece.

Resin

A sticky, sap base substance that has hardened.

Ripping

A cutting operation along the length of the workpiece.

Revolutions Per Minute (RPM)

The number of turns completed by a spinning object in one minute.

glossary of terms for woodworking

Sawblade Path

The area of the workpiece or table top directly in line with the part of the workpiece which will be, or has been, cut by the blade.

Set

The distance that the tip of the sawblade tooth is bent (or set) outward from the face of the blade.

Throw-Back

Throwing of pieces in a manner similar to a kickback.

Thru-Sawing

Any cutting operation where the blade extends completely through the thickness of the workpiece.

Trailing End

The workpiece end last cut by the blade in a ripping operation.

Workpiece

The item on which the cutting operation is being done. The surfaces of a workpiece are commonly referred to as faces, ends, and edges.

motor specifications and electrical requirements

MOTOR SPECIFICATIONS

The motor used in this saw is a relay start, non-reversible type, with the following specifications:

Voltage	120
Amperes	11.5
Hertz	60
Phase	Single
RPM	3450
Rotation (viewed from sawblade end)	Counterclockwise

CAUTION: The starting relay in this switch housing is a gravity sensitive type. To avoid damaging your motor, never turn power on unless the saw is upright in sawing position.

MOTOR SAFETY PROTECTION

1. Frequent opening of fuses or circuit breakers may result if motor is overloaded, or if the motor circuit is fused with a fuse other than those recommended. Do not use a fuse of greater capacity without consulting the power company.
2. Although the motor is designed for operation on the voltage and frequency specified on motor nameplate, minimal loads will be handled safely at voltages 10% above or below the nameplate voltage. Heavy loads, however, require that voltage at motor terminals be not less than the voltage specified on nameplate.
3. Most motor troubles may be traced to loose or incorrect connections, overloading, reduced input voltage (which results when small size wires are used in the supply circuit) or when the supply circuit is extremely long. Always check connection, load and supply circuit when the motor fails to perform satisfactorily. Check wire sizes and lengths with table at end of this section.

CONNECTING TO POWER SOURCE OUTLET

This saw must be grounded while in use to protect the operator from electrical shock.

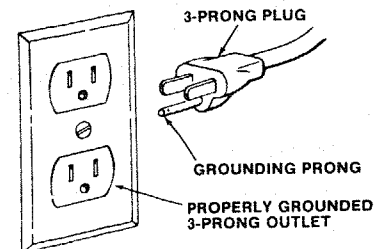

Your saw is wired for 120 volts and it has a plug that looks like the one shown.

Plug power cord into a 110-120V properly grounded type outlet protected by a 15 amp. time delay or Circuit-Saver fuse or circuit breaker.

WARNING: Damaged power cords can cause shock or fires. If the power cord is worn, cut, or damaged in any way, have it replaced immediately.

WARNING: Electric shock can kill. Not all outlets are properly grounded. If you are not sure that your outlet is properly grounded, have it checked by a qualified electrician.

WARNING: To avoid electrical shock, do not permit fingers to touch the terminals of the plug, when installing or removing the plug to or from the outlet.

WARNING: Failure to properly ground this power tool can cause electrocution or serious shock, particularly when used in damp locations, or near metal plumbing. If shocked, your reaction could cause your hands to hit the cutting tool.

This saw is equipped with a 3-conductor cord and grounding type plug which been approved by Underwriters' Laboratories. The ground conductor has a green jacket and is attached to the tool housing at one end and to the ground prong in the attachment plug at the other end.

This plug requires a mating 3-conductor grounding type outlet as shown.

WARNING: Avoid electric shock. If the outlet you are planning to use for this saw is of the two prong type, DO NOT REMOVE OR ALTER THE GROUNDING PRONG IN ANY MANNER. Use an adapter, as shown, and always connect the grounding lug to a known ground.

It is recommended that you have a qualified electrician replace the TWO prong outlet with a properly grounded THREE prong outlet.

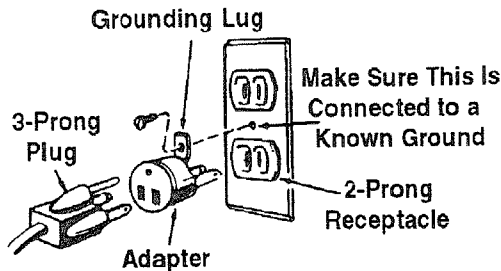

An adapter, as shown, is available for connecting plugs to 2-prong receptacles. The green grounding lug extending from the adapter must be connected to a permanent ground such as to a properly grounded outlet box. The temporary adapter should be used only until a properly grounded outlet can be installed by a qualified electrician.

WARNING: To help avoid electric shock, the green grounding lug extending from the adapter must be connected to a permanent ground such as to a properly grounded outlet box. Not all outlet boxes are properly grounded. If you are not sure the outlet box is properly grounded, have it checked by a qualified electrician.

NOTE: The adapter illustrated is for use only if you already have a properly grounded 2-prong receptacle. **NOTE:** make sure the proper extension cord is used and is in good condition.

The use of any extension cord will cause some loss of power. To keep this to a minimum and to prevent overheating and motor burn-out, use the table below to determine the minimum wire size (A.W.G.) extension cord. Use only 3 wire extension cords which have 3-prong grounding type plugs and 3-pole receptacles which accept the tool plug.

Extension Cord Length	Wire Size A.W.G.
0 - 25 Ft.	16
26 - 50 Ft.	14

contents

Warranty	2
Safety Instructions for Table Saw	2
Additional Instructions for Rip Type Cuts	4
Additional Instructions for Cross Cut Type Cuts	5
Glossary	5
Motor Specifications and Electrical Requirements	6
Motor Specifications	6
Motor Safety Protection	6
Connecting to Power Source Outlet	6
General Information	8
Model Description	8
Unpacking and Checking Contents	8
Tools Needed	8
List of Loose Parts (Model 113.226880)	9
List of Loose Parts (Model 113.298090)	10
Assembly	12
Assembly of Steel Leg Set	12
Mounting Saw to Leg Set (Model 113.226880)	12
Installing Bevel Pointer and Handwheels	13
Checking and Adjusting Table Insert	14
Heeling Adjustment or Parallelism of Sawblade to Miter Gauge Groove	14
Blade Tilt, or Squareness of Blade to Table	15
Blade Elevations	17
Tilt and Elevation Mechanism	18
Attaching and Assembly Table Extensions (Model 113.226880)	18
Installing Rip Fence Guide Bars and Switch Box (Model 113.226880)	19
Attaching and Assembling Table Extensions (Model 113.298090)	22
Installing Rip Fence Guide Bars and Switch Box (Model 113.298090)	23
Mounting Saw to Leg Set (Model 113.298090)	25
Aligning Table Extensions (Model 113.298090)	25
Mounting Saw to Workbench	26
Self-Aligning Spring Adjustment	27
Rip Fence Alignment Adjustment	28
Adjusting Rip Scale Indicator	28

Installing Blade Guard	29
Adjusting Miter Gauge	31
Getting to Know Your Saw	32
On-Off Switch	32
Elevation Handwheel	33
Tilt Handwheel	33
Rip Fence	33
Miter Gauge	33
Blade Guard	33
Table Insert	33
Removing and Installing Sawblade	34
Exact-I-Cut	34
Basic Saw Operation	35
Work Helpers	35
Safety Instructions for Basic Saw Operation	36
Using the Miter Gauge	38
Crosscutting	38
Repetitive Cutting	39
Miter Cutting	39
Bevel Cutting	40
Compound Miter Cutting	40
Using the Rip Fence	40
Ripping	41
Using Featherboards For Thru Sawing	
Resawing	43
Using Featherboards for Non Thru-Sawing	44
Rabbeting	44
Ploughing and Molding	45
Cutting Panels	45
Dadoing	45
Molding Cutting	45
Motor	46
Lubricating and Maintenance	46
Maintenance	46
Lubrication	47
Recommended Accessories	47
Troubleshooting	48
General	48
Motor	49
Repair Parts	50

general information

BOTH MODELS

1. This manual is for the following Models, 113.226880 or 113.298090.

All sections are labeled with the correct model number. Follow ONLY instructions that are meant for your model saw.

2. If you are missing any part(s) while putting your saw together, do not continue assembly. Contact your Sears Service Center or Retail Store and get the missing part(s) before continuing assembly or trying to use the saw.

Complete parts lists are located at the end of this manual. Use these lists to identify the part number of any missing part.

3. Sometimes small parts get lost in packaging materials. Do not throw away any packaging until your saw is put together. If you are missing a part, check the packaging before contacting Sears.

MODEL DESCRIPTION

Model 113. 226880: 10-inch direct drive table saw with a 20 x 20 inch CAST IRON table and two 10 x 20-inch CAST IRON extensions.

Model 113. 298090: 10-inch direct drive table saw with a 20 x 27-inch die cast ALUMINUM table and two 10 x 27-inch STAMPED STEEL extensions.

unpacking and checking contents

TOOLS NEEDED

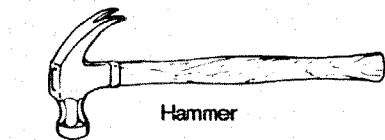

Hammer



Medium Screwdriver
Small Screwdriver



Pliers



#2 Phillips Screwdriver

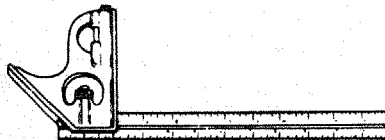

Combination Square



Wrench, Hex "L" 3/16
Wrench, Hex "L" 1/8



Wrenches
3/8 in. 7/16 in.
1/2 in. 9/16 in.

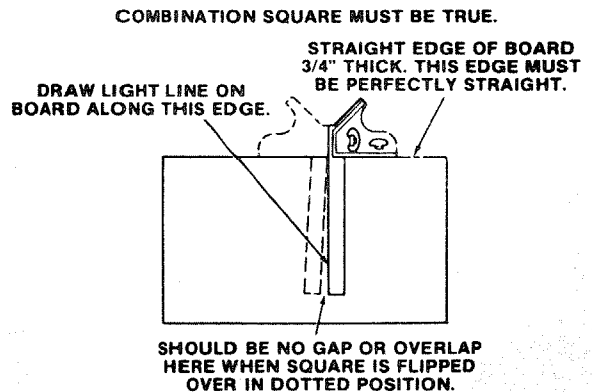

Model 113.226880 or 113.298090 is shipped complete in one carton and includes two table extensions, steel legs and motor.

Separate all parts from packing materials and check each one with the illustration and the list of Loose Parts to make certain all items are accounted for, before discarding any packing material.

WARNING: If any parts are missing, do not attempt to assemble the table saw, plug in the power cord or turn the switch on until the missing parts are obtained and are installed correctly.

Remove the protective oil that is applied to the table top and edges of the table. Use any ordinary household type grease and spot remover.

WARNING: To avoid fire or health hazard, never use gasoline, naphtha or similar highly volatile solvents.

Apply a coat of automobile wax to the table.

Wipe all parts thoroughly with a clean, dry cloth.

WARNING: For your own safety, never connect plug to power source outlet until all assembly steps are complete, and you have read and understand the safety and operation instructions.

MODEL 113.226880

LIST OF LOOSE PARTS

Item	Part Name	Qty.
A	Miter Gauge	1
B	Rip Fence	1
C	Blade Guard and Spreader	1
E	Rip Fence Guide Bar, Rear	1
F	Leg	4
G	Table Extension	2
H	Side Stiffener	2
J	End Stiffener	2
K	Rip Fence Guide Bar with Rip Scale (Front)	1
	Bag of Loose Parts	1
	Containing the following:	
M	Leveling Foot	4
N	Hex Jam Nut, 3/8-16	8
O	Hex Nut, 1/4-20	24
P	Truss Hd. Screw, 1/4-20 x 1/2	24
Q	Lockwasher, #10 External	24
	Bag of Loose Parts	1
	Containing the following:	
P	Truss Hd. Screw, 1/4-20 x 5/8	2
Q	Lockwasher, #10 External	2
U	Spreader Support	1
V	Switch Key	1
W	Pan Hd. Screw, 10-32 x 5/8	2
Q	Lockwasher, 1/4 In. External	2
X	Soc. Set Screw, 1/4-20 x 7/8	2
Y	Wing Nut, 1/4-20	2
Z	Square Nut, 1/4-20	2
	Bag of Loose Parts	1
	Containing the following:	
N	Jam Nut, 5/16-18	6
Q	Lockwasher, 5/16 External	6
S	Spreader Clamp	1
T	Spreader Bracket	1
AA	Hex Screw, 5/16-18 x 1	6
BB	Washer, 21/64 x 5/8 x 1/16	6
	Bag of Loose Parts	1
	Containing the following:	
D	Handwheel	2
R	Bracket	2
DD	Wrench	2
EE	Bevel Pointer	1
FF	Wire Tie	1
	Bag of Loose Parts	1
	Containing the following:	
N	Hex Jam Nut, 5/816-18	6
O	Hex Nut, 1/4-20	2
Q	Lockwasher, 5/16 External	8
AA	Hex Hd. Screw, 5/16-18 x 1	5
AA	Hex Hd. Screw, 5/16-18 x 1-1/2	3
BB	Washer, 17/64 x 9/16 x 3/64	4
BB	Washer, 21/64 x 5/8 x 1/16	8
CC	Fence Guide Bar Spacer	3

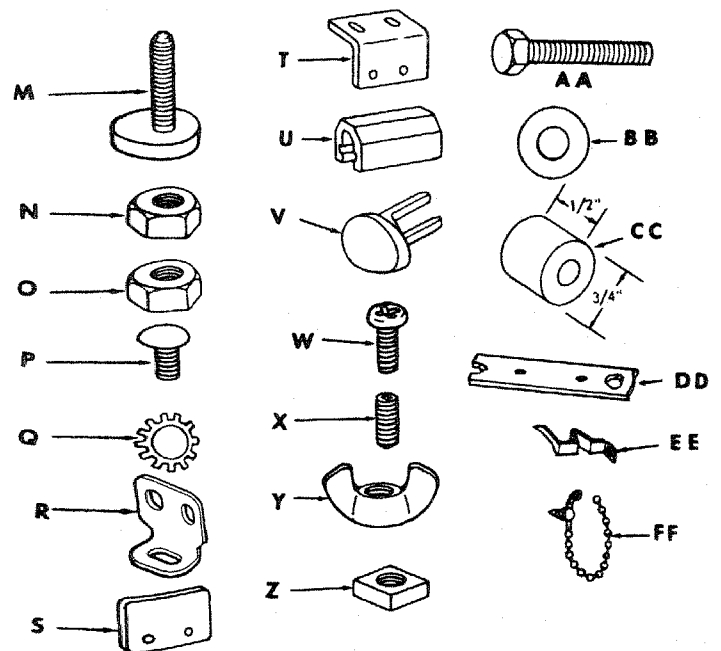
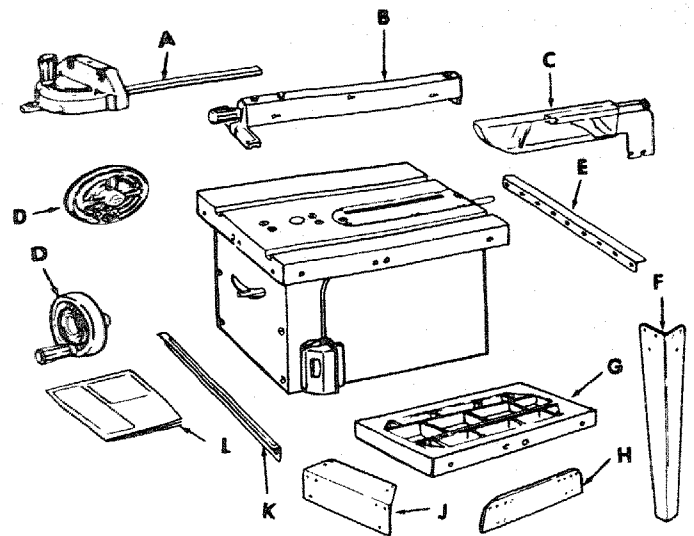

	Bag of Loose Parts	1
	Containing the following:	
O	Hex Jam Nut, 5/16-18	6
Q	Lockwasher, 1/4 External	2
Q	Lockwasher, 5/16 External	8
W	Pan Head Screw, 8-32 x 3/8 Type "T"	1
AA	Hex Hd. Screw, 5/16-18 x 3/4	2
AA	Hex Hd. Screw, 5/16-18 x 1-1/4	4
BB	Washer, 11/32 x 11/16 x 1/16	8

unpacking and checking contents

MODEL 113.298090

LIST OF LOOSE PARTS

Item	Part Name	Qty.
A	Miter Gauge	1
B	Rip Fence	1
C	Blade Guard and Spreader	1
E	Rip Fence Guide Bar, Rear	1
F	Rip Fence Guide Bar with Rip Scale (Front)	1
H	Leg	4
J	Side Stiffener	2
K	End Stiffener	2
L	Table Extension	2
	Bag of Loose Parts	1
	Containing the following:	
D	Handwheel	2
G	Wrench	2

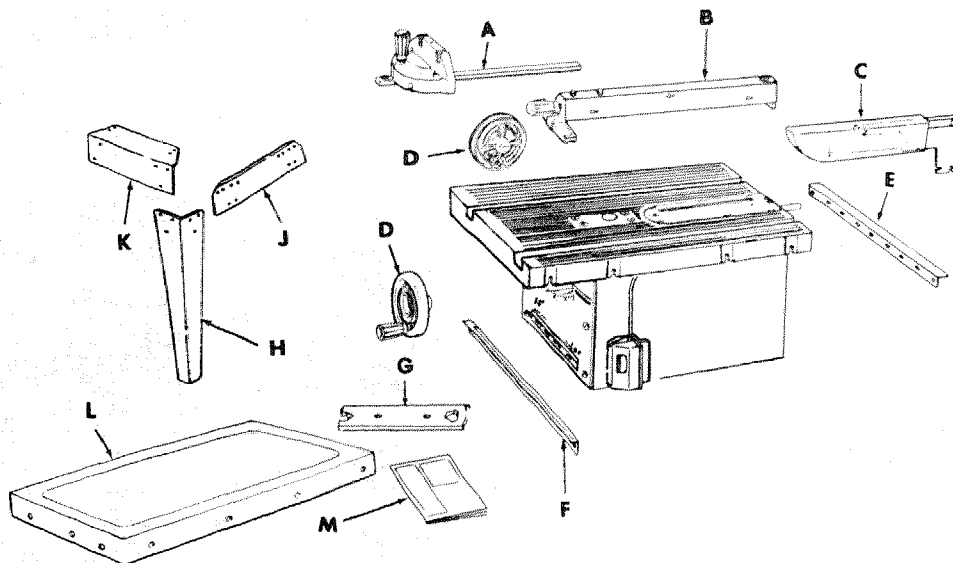

Bag of Loose Parts	1
Containing the following:	
N Spreader Support	1
O Spreader Clamp	1
P Spreader Bracket	1
Bag of Loose Parts	1
Containing the following:	
Q Switch Key	1
U Soc. Hd. Setscrew 1/4-20x7/8	2
T Square Nut, 1/4-20	2
X Lockwasher, #10 External Type	2
X Lockwasher, 1/4 External Type	2
Y Wing Nut, 1/4-20	2
AA Pan Hd. Screw, 10-32x5/8	2
BB Truss Head Screw, 1/4-20x5/8	2
Bag of Loose Parts	1
Containing the following:	
R Flat Washer 17/64x9/16x3/64	4
R Flat Washer 21/64x5/8x1/16	4
V Guide Bar Spacer	3
W Hex Nut, 1/4-20	2
W Hex Jam Nut, 5/16-18	10
X Lockwasher, 1/4 in. External Type	2
X Lockwasher, 5/16 in. External Type	10
Z Hex Hd. Screw, 5/16-18x1	3
Z Hex Hd. Screw, 5/16-18x1-1/2	3
Z Hex Hd. Screw, 5/16-18x1-1/4	4

Bag of Loose Parts	1
Containing the following:	
W Hex Nut, 1/4-20	24
W Hex Jam Nut, 3/8-16	8
X Lockwasher, 1/4 External Type	24
BB Truss Head Screw, 1/4-20x1/2	24
CC Leveling Foot	4
Bag of Loose Parts	2
Containing the following:	
R Flat Washer 17/64x3/4x1/16	4
R Flat Washer 11/32x1 1/16x1/16	8
R Flat Washer 21/64x5/8x1/16	8
W Hex Nut, 1/4-20	16
W Hex Jam Nut, 5/16-18	8
X Lockwasher, 1/4 External Type	16
X Lockwasher, 5/16 External Type	8
Z Hex Head Screw, 5/16-18x1-1/4	8
BB Truss Head Screw, 1/4-20x1	16
Bag of Loose Parts	1
Containing the following:	
DD Corner Stiffener Bracket	4
EE Corner Support Bracket	4
Bag of Loose Parts	1
Containing the following:	
W Hex Jam Nut, 5/16-18	2
X Lockwasher, External 5/16	4
Z Hex Hd. Screw, 5/16-18x3/4	2
AA Pan Cross Screw, Ty "T", 8-32x3/8	1
FF Tie Wire	1
GG Bracket	2
HH Bevel Pointer	1

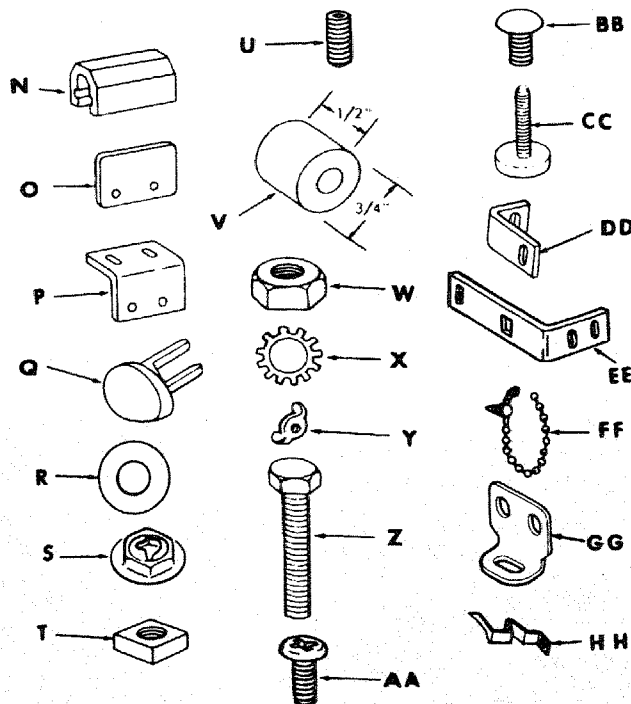

assembly

BOTH MODELS

ASSEMBLY OF STEEL LEG SET

Assembly is best done in the location where the saw will be used.

- From among the loose parts, find the following hardware:
 - 4 Leveling Feet
 - *8 Hex Nuts, 3/8-16
 - *24 Truss Head Screws, 1/4-20 x 1/2
 - *24 Hex Nuts, 1/4-20
 - *24 1/4 External Lockwashers

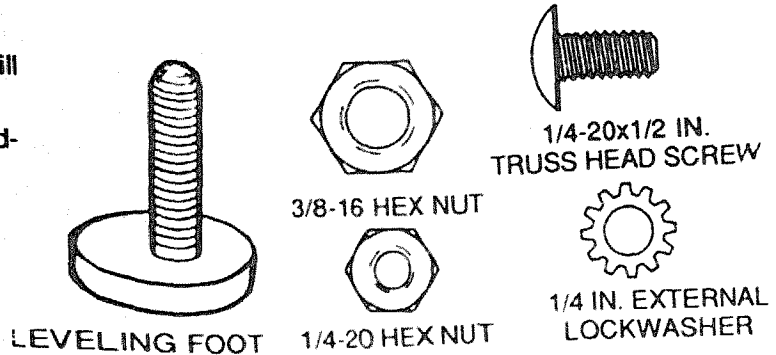

Items marked with an asterisk (*) are shown actual size.

- Insert three truss head screws through the three holes near the top of one Leg. Place the Side Stiffener up to the Leg, as shown, so that the three screws line up with the holes in the Side Stiffeners marked with an "X" in the illustration.
- Place a lockwasher and hex nut on each screw and finger tighten the hex nut.
- Following the same procedure as above, continue to fasten together the remaining Legs and Stiffeners as illustrated.
- Install one 3/8-16 hex nut on each of the Leveling Feet.
- Insert a Leveling Foot through the hole in the bottom of each Leg so the Leveling Foot pad rests on the floor.
- Install another 3/8-16 hex nut on each of the Leveling Feet.
- Set leg set upright on floor and securely tighten all nuts.
- After complete assembly, you may level the saw by moving the lower nut up or down along the threaded stud of each Leveling Foot. The upper nut is used to lock the Leveling Foot into position when the saw is level.

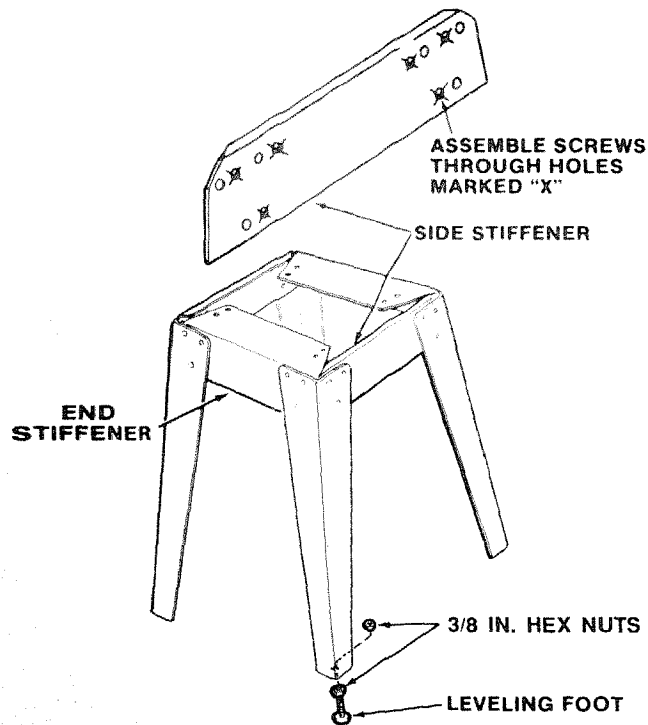

MODEL 113.226880 ONLY

MOUNTING YOUR SAW TO THE LEG SET (Model 113.298090 will be mounted later)

- From among the loose parts, find the following hardware:
 - *4 Hex Head Screws, 5/16-18 x 1-1/4
 - *4 Hex Nuts, 5/16-18
 - *4 Lockwashers, 5/16 In. External
 - *8 Flat Washers, 11/32 x 11/16 x 1/16

Items marked with an asterisk (*) are shown actual size.

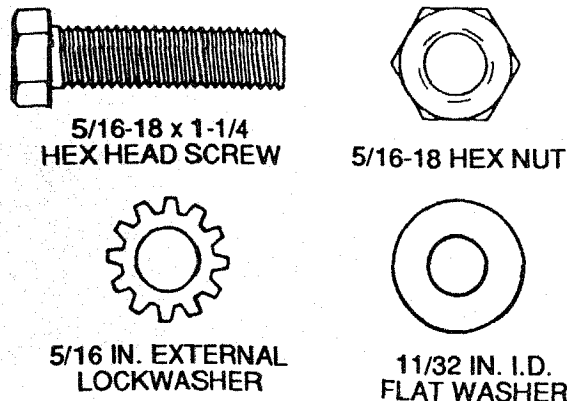

2. Place the saw on top of the leg set so that the base of the saw lines up approximately even with the outline of the top of the leg set.
3. From beneath the saw you will be able to locate and line up the four mounting holes of the saw base with the proper mounting holes of the saw base with the proper mounting holes in the leg set assembly.
4. Place one flat washer onto each of the four hex head screws and insert them into each of the mounting holes. Be sure the screws go through the saw base holes and the leg set mounting holes.

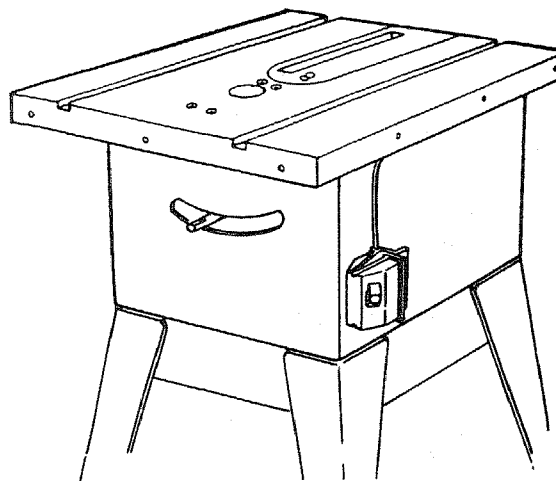

5. Install a flat washer, lockwasher, and a hex nut on each of the four screws and tighten securely.
6. Level the saw to your requirements by adjusting the leveling feet. Lock leveling feet into position.
7. Securely tighten all leg set screws and nuts.

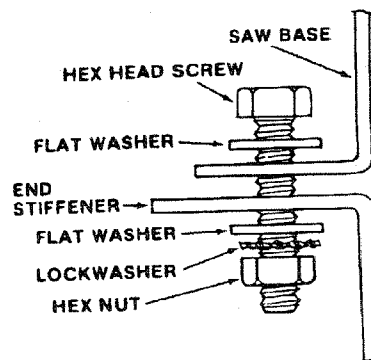

BOTH MODELS INSTALLING BEVEL POINTER AND HANDWHEELS

1. From among the loose parts, find the following hardware:

- 1 Bevel Pointer
- *1 Screw, 8-32 x 3/8
- 2 Handwheels
- 2 Screw, Phillips 10-32 x 5/8
- *2 Lockwasher, External 3/16

Items marked with an asterisk (*) are shown actual size.

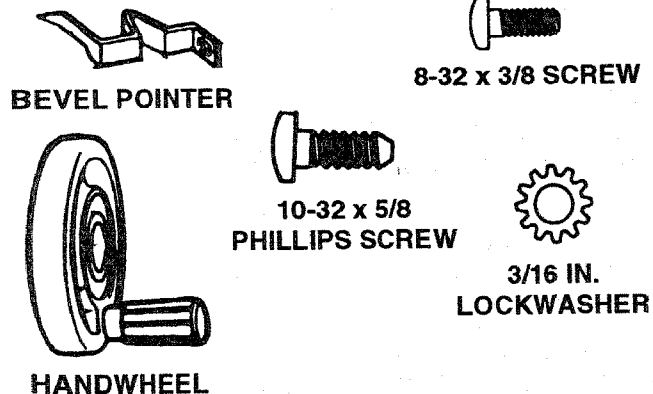

2. Fasten bevel pointer to cradle assembly with 8-32 x 3/8 screw, as shown. Adjustment of the pointer may be necessary later.
3. Push handwheels onto shafts, as shown, and fasten each with a 10-32 x 5/8 phillips screw and lockwasher.

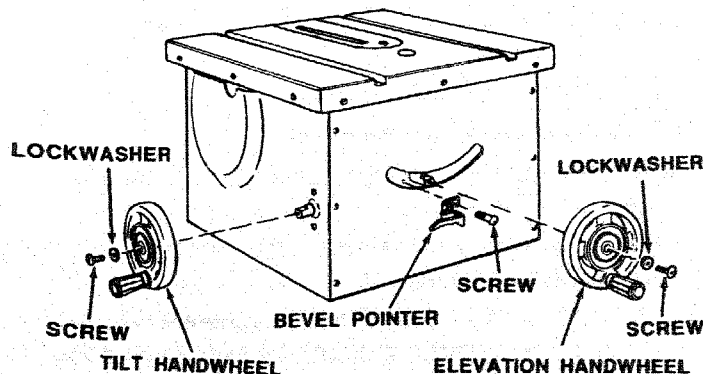

assembly

CHECKING AND ADJUSTING THE TABLE INSERT

The table insert must be flush with the surface of the saw table to keep the workpiece from hanging up or binding with the sawblade as the workpiece is cut by the sawblade.

1. Lower sawblade beneath the table insert and check to be sure the screw fastening the insert in place is snug.
2. Use a straight edge to check near each of the eight leveling tab positions to determine if the insert is flush with the surface of the saw table at all eight leveling tab positions.
3. If insert is not flush with table surface, loosen insert fastening screw and pull insert forward to lift from saw table.

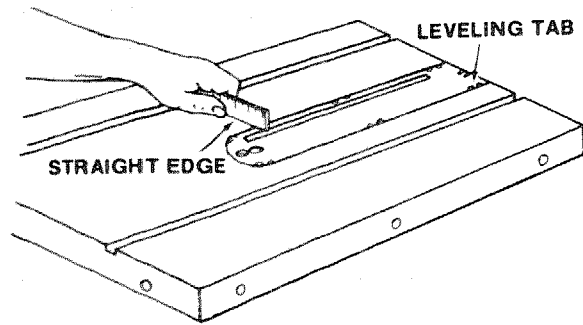

4. Bend with pliers or tap with a hammer, as required, to make the insert flush with the table top.

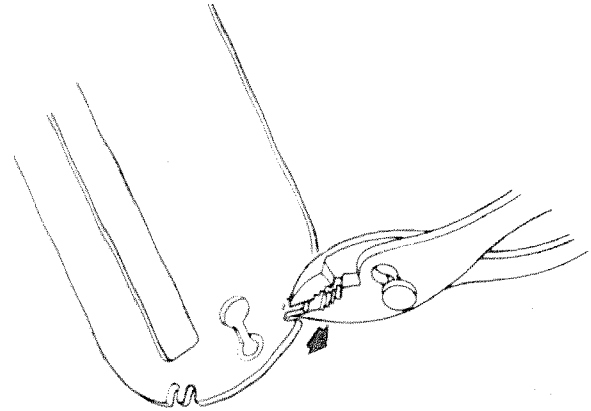
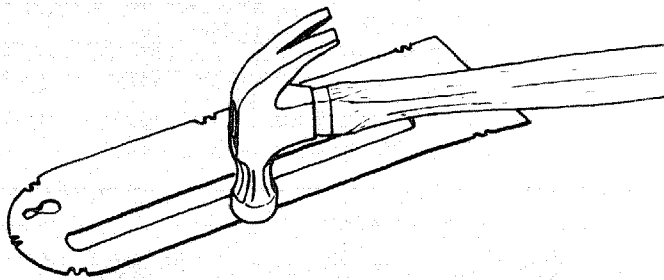

HEELING ADJUSTMENT OR PARALLELISM OF THE SAWBLADE TO THE MITER GAUGE GROOVE

While cutting, the material must move in a straight line PARALLEL to the SAWBLADE, therefore, both the Miter Gauge GROOVE and the RIP FENCE must be PARALLEL to the SAWBLADE.

WARNING: If the sawblade is NOT parallel with the Miter Gauge Groove, it is said to have 'HEEL'. This condition can cause the workpiece to bind or move away from the Rip Fence at the end of a rip cut, possibly causing a kickback.

WARNING: To avoid injury from accidental start, make sure switch is "OFF" and plug is not connected to power source outlet.

1. Raise blade to highest elevation.
2. Lift Blade Guard, if already installed, to highest position.
3. Mark an "X" on one of the teeth of the sawblade which is naturally bent to the left.
4. Place the head of a combination square in the left Miter Gauge Groove and adjust the ruler blade of the square so that the end of the blade just touches the

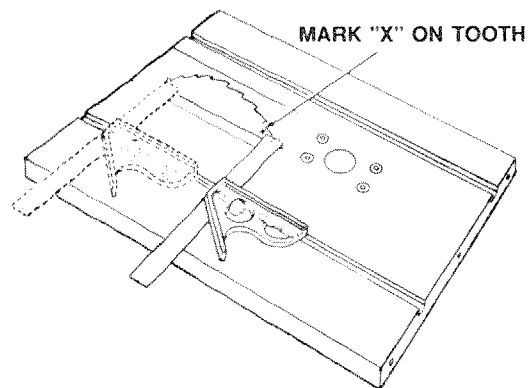

5. Rotate the sawblade so that the "X" on the tooth is now visible at the rear of the saw.
6. Move the combination square to the rear of the saw and the end of the square blade should just touch the marked tooth the same as it did at the front of the sawblade.

7. If sawblade is not parallel with the Miter Gauge Groove, you must adjust the position of the sawblade. Use a 3/16 in. hex "L" wrench to loosen the four adjustment locking screws about 1/2 turn.
8. Loosen two pan head screws on the rear skirt of the table about 1/2 turn.
9. The mechanism under the table can now be moved sideways from above by covering the sawblade with a piece of cardboard and shifting the blade to the right or left as required.
10. After shifting the sawblade mechanism slightly, re-check the position of the marked tooth of the sawblade at both front and rear.
11. The tooth marked on the sawblade should be parallel to the Miter Gauge Groove after adjustment is made.
12. Tighten all screws carefully so as not to move sawblade out of alignment.
13. Re-check parallelism of marked sawblade tooth to the Miter Gauge Groove. Repeat the steps for heeling adjustment if necessary.

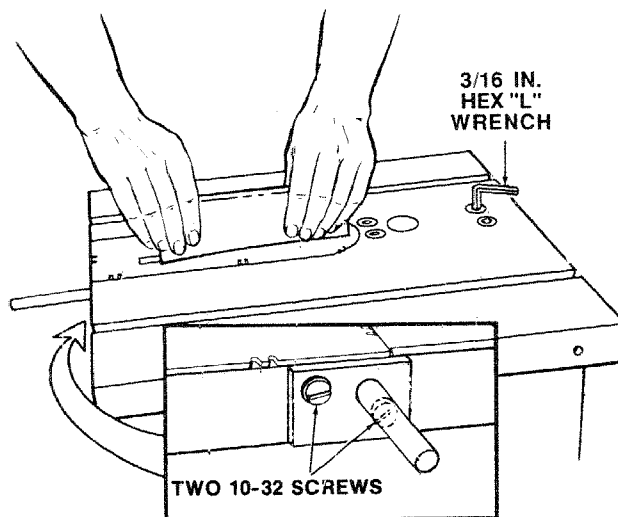

113.226880 SHOWN
113.298090 IS SIMILAR

BLADE TILT, OR SQUARENESS OF BLADE TO TABLE

When the Bevel Pointer is pointing directly to the "0" mark on the Bevel Scale, the sawblade should make a SQUARE cut 90° to the table.

90° Position

To check for SQUARENESS:

WARNING: To avoid injury from accidental start, turn switch "OFF" and remove plug from power source outlet before adjusting bevel stop.

1. Raise blade all the way UP, raise Blade Guard.
2. TILT blade a few degrees to the LEFT. Now, tilt blade back to the RIGHT as far as it will go.
3. Place the square against blade. Make sure square is not touching the TIP of one of the saw TEETH.

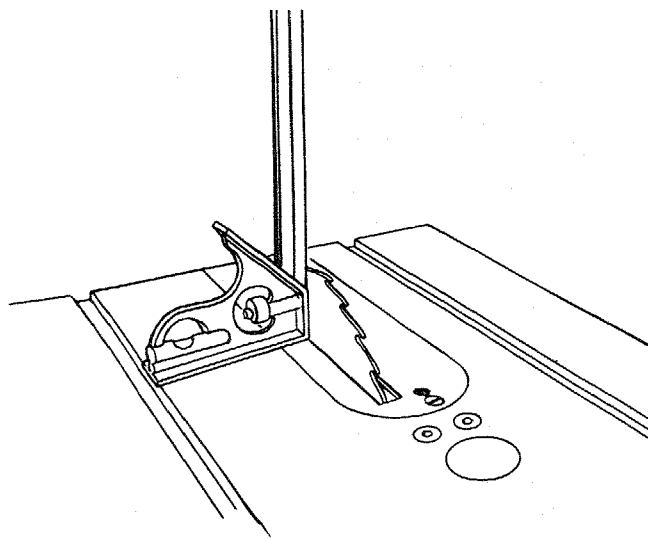

assembly

4. If blade is SQUARE to table; check pointer.
 - A. If Pointer DOES NOT point to "0" mark on the Bevel Scale, bend pointer to read "0".

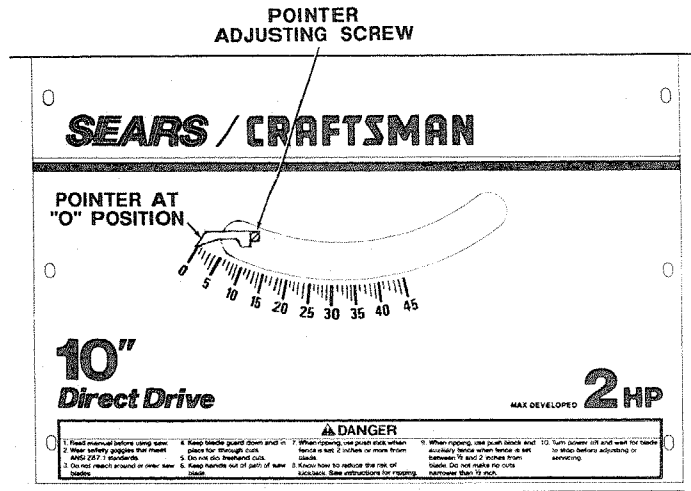

5. If blade is NOT SQUARE to table, the 90° Limit Stop must be adjusted.

CAUTION: Cover blade with piece of cardboard to protect your hand.

- A. Using a small size screwdriver, reach underneath saw and loosen BOTH setscrews in 90° Stop Collar.

NOTE: If you can't reach the setscrews turn the Tilt Handwheel slightly.
- B. Rotate the Stop Collar moving it away from pivot nut.
- C. Tilt blade RIGHT or LEFT, checking with your square until blade is square to table.
- D. Rotate Stop Collar toward Pivot Nut until it TOUCHES the Pivot Nut. Tighten the setscrews.
- E. Check Pointer, if it DOES NOT point to the "0" mark on the bevel scale, bend Pointer to read "0".

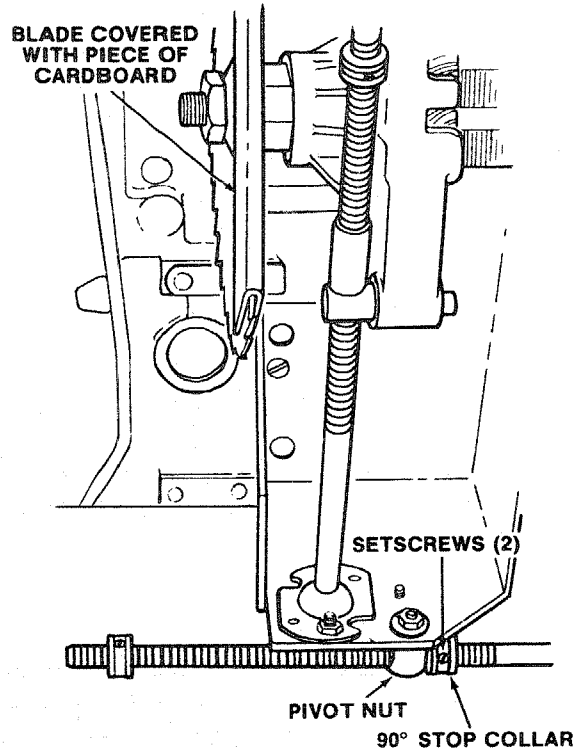

6. Tilt blade to LEFT as far as it will go. It will stop when the Pivot Nut is against the 45° Stop Collar.
7. Place an ACCURATE square against blade. Make sure square is not touching the TIP of one of the saw teeth.

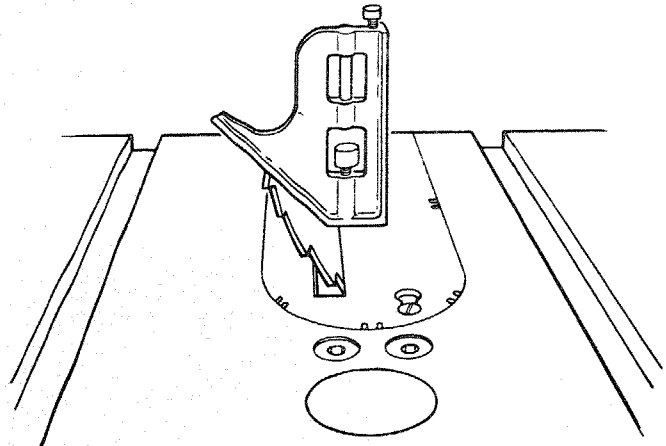

8. If blade is NOT 45° to table, the 45° Stop Collar must be adjusted.

A. Remove Elevation Handwheel.

B. Using a small size screwdriver, reach thru curved slot in front trim panel and loosen BOTH setscrews in 45° Stop Collar.

NOTE: If you can't reach the setscrews, turn the Tilt Handwheel slightly.

C. Rotate the Stop Collar moving it IN or OUT and tilt blade RIGHT or LEFT, checking with your square, until blade is 45° to table.

D. Tighten the setscrews.

NOTE: If you can't reach the setscrews, turn Tilt Handwheel slightly.

E. Install Elevation Handwheel.

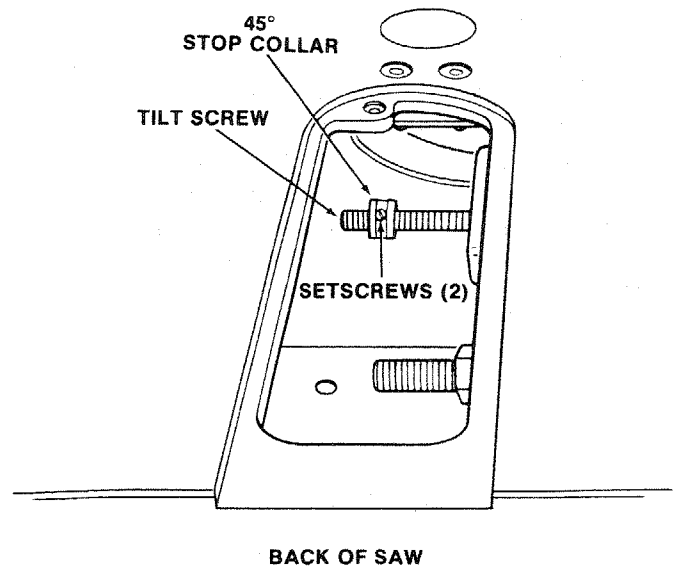

BLADE ELEVATION

When the Elevation Handwheel is turned CLOCKWISE, until it stops, the blade must not be more than 2-5/8 inches above the table. If the blade extends more than 2-5/8 inches, the motor could interfere with the underside of the table causing misalignment.

With the blade extending 2-5/8 inches above the table, the Stop Collar and Spacer must be against the Elevation Screw Pivot Nut. If the blade extends more than 2-5/8 inches, loosen two screws in Stop Collar, and readjust it.

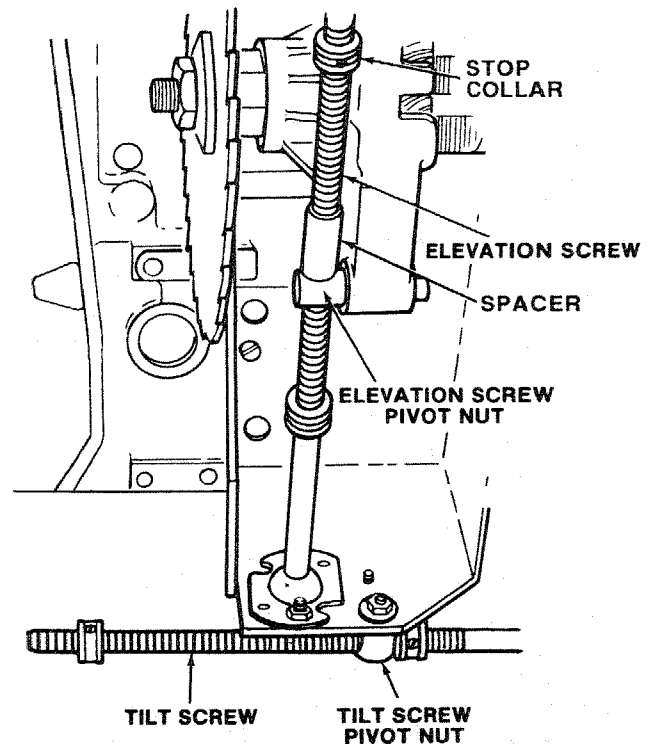

assembly

TILT AND ELEVATION MECHANISM

The Handwheels should turn freely without binding. The turning action can be adjusted by tightening or loosening the screws in the Bearing Retainer. Both Handwheels must be removed to reach the adjusting screws.

NOTE: When adjusting the screws on the Tilt Bearing Retainer, hold the nut inside using a 3/8 inch wrench. The screws for the Elevation Bearing Retainer can be reached with a small screwdriver through the curved slot on the front of the saw.

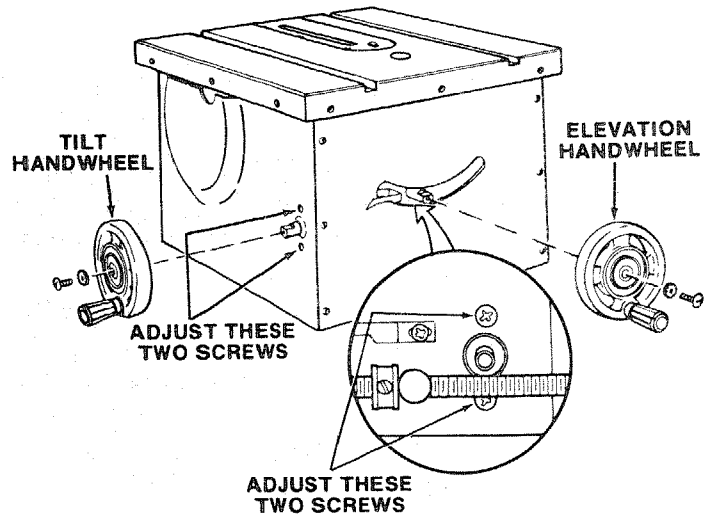

MODEL 113.226880 ONLY

ATTACHING AND ASSEMBLING TABLE EXTENSIONS

1. From among the loose parts, find the following hardware: (Quantity indicated is for 2 extensions.)

- *8 Hex Hd. Screw 5/16-18 x 1
- *8 Flat Washer, 21/64 x 5/8 x 1/16
- *8 Lockwasher, External 5/16
- *8 Hex Jam Nut, 5/16-18
- 2 Brackets

Items marked with an asterisk (*) are shown actual size.



5/16-18 x 1
HEX HD. SCREW

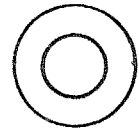

11/32 IN. I.D.
FLAT WASHER

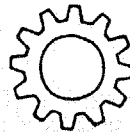

5/16 IN. EXTERNAL
LOCKWASHER

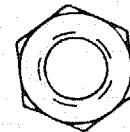

5/16 IN.
HEX NUT

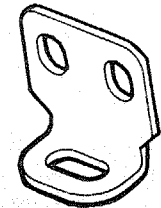

BRACKET

2. Insert three (3) 5/16-18 x 1 inch long screws through holes in table.
3. Position Extension against table so screws extend through holes in Extension.
4. Install flat washer, lockwashers, and nuts on the screws. **HAND TIGHTEN ONLY.**
5. Install other extension in the same way on other side of table.

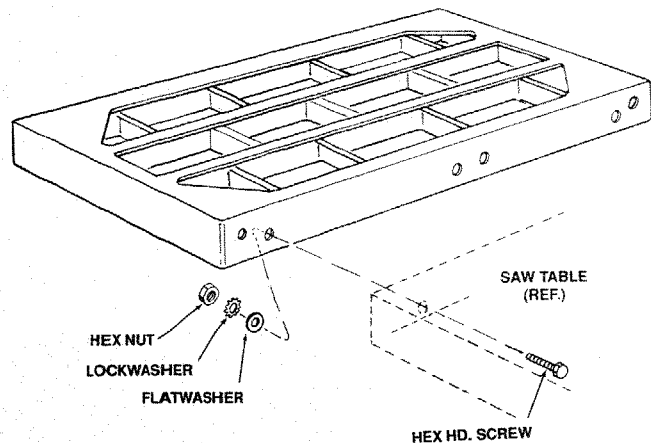

- Line up front and top surface of the Extension with the front and top of the table at the spots marked "X" in the drawing. Use a combination square to line up these edges. Tighten bolts and nuts securely.

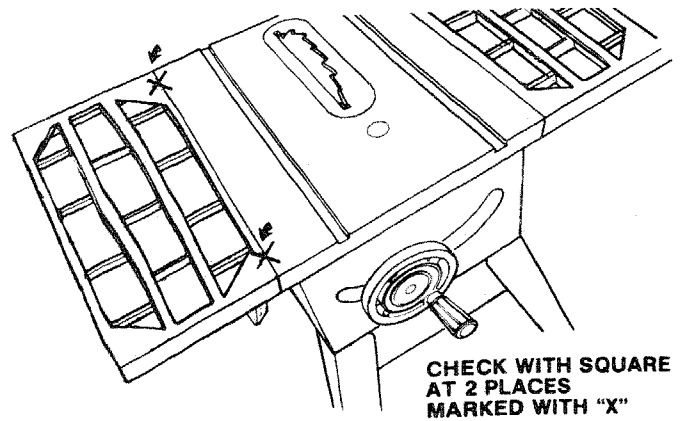

- Put one of the brackets against the right edge of the right extension so the bracket is lined up with the FIRST hole near the front of the extension. Insert a 1 inch long screw through a flat washer, through top hole in the bracket, and through the FIRST hole in the extension. Install a lockwasher and nut on the screw. Hand tighten the nut.
- Put one of the brackets against the right rear edge of the right extension so the bracket is lined up with the SIXTH hole at the rear of the extension (see illustration).
- Insert one of the 1 inch long screws through a flat washer, through the bracket, and through the SIXTH hole into the extension. Install a lockwasher and nut on the screw. Hand tighten the nut.

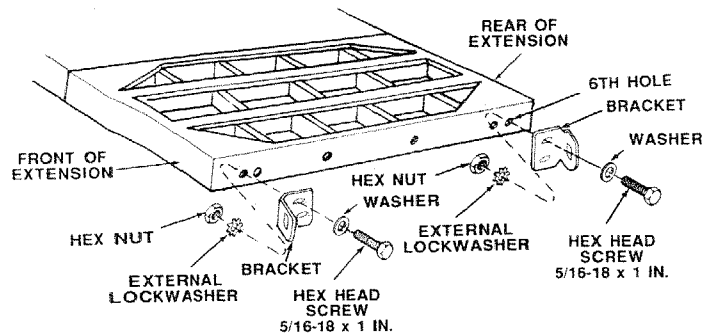

MODEL 113.226880 ONLY
INSTALLING RIP FENCE GUIDE BARS
AND SWITCH BOX

- From among the loose parts, find the following hardware:
 - *3 Hex Head Screws, 5/16-18 x 1-1/2
 - *3 Hex Head Screws, 5/16-18 x 1
 - *2 Hex Head Screws, 5/16-18 x 3/4
 - *10 Lockwashers, 5/16 External
 - *6 Hex Jam Nuts, 5/16-18
 - *6 Flat Washers, 21/64 x 5/8 x 1/16
 - *3 Spacers, 3/4 diameter x 1/2 long

Items marked with an asterisk (*) are shown actual size.

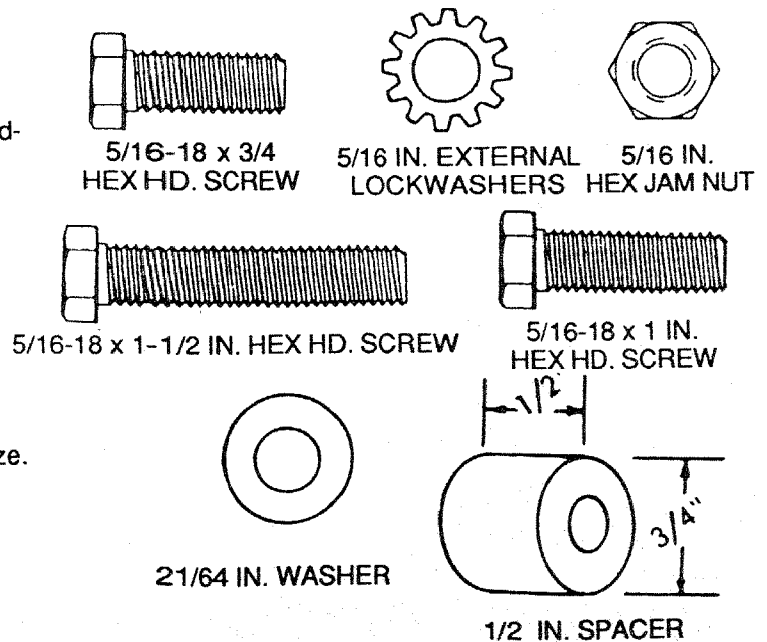

assembly

2. Insert a 5/16-18 x 1-1/2 inch long hex head screw, external lockwasher and flat washer through the SECOND slot in the front fence bar.
3. Place 1/2 inch long Spacer over screw threads and thread hex head screw into first hole on the right side of the cast iron table skirt until finger tight. Guide Bar should be in a vertical position.

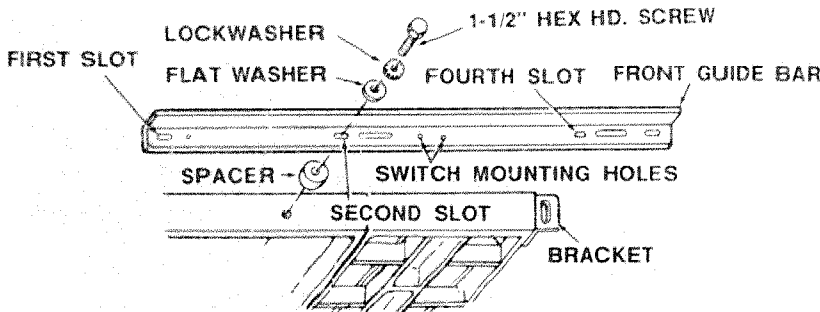
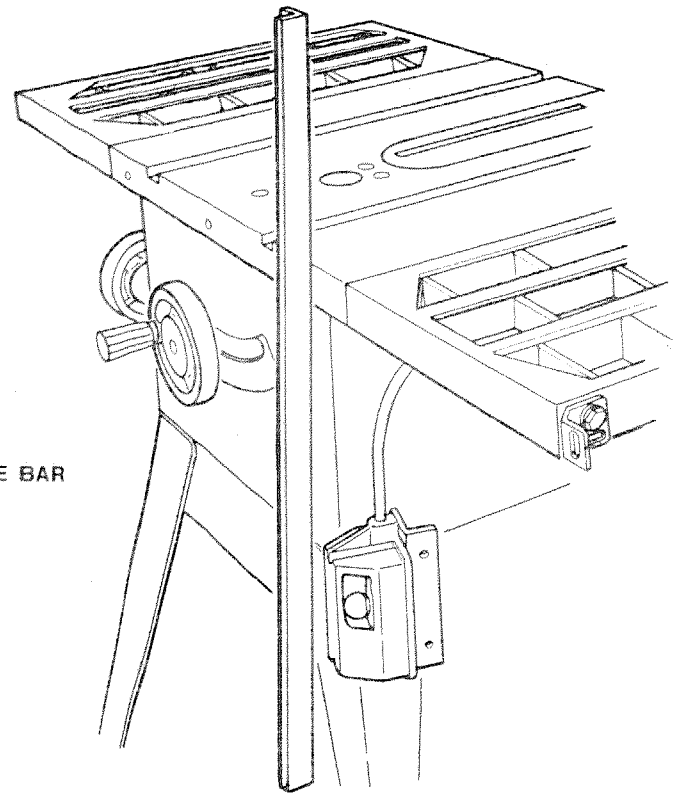

4. Mount Switch to Guide Bar with (2) two 5/16-18 x 3/4 hex head screws, lockwashers, and nuts. Securely tighten both bolts.
5. Insert 1-1/2 inch long screw through external lockwasher, flat washer and through the first slot in the Guide Bar. Place 1/2 inch long Spacer over screw threads. Swing Guide Bar to horizontal position and thread the hex head screw into the hole of the table skirt. Finger tighten.
6. Insert 1-1/2 inch long screw through flat washer and the FOURTH slot in the Guide Bar. Place 1/2 inch long spacer over screw threads. Insert screw into slot in bracket and attach a lockwasher and nut. Finger tighten.

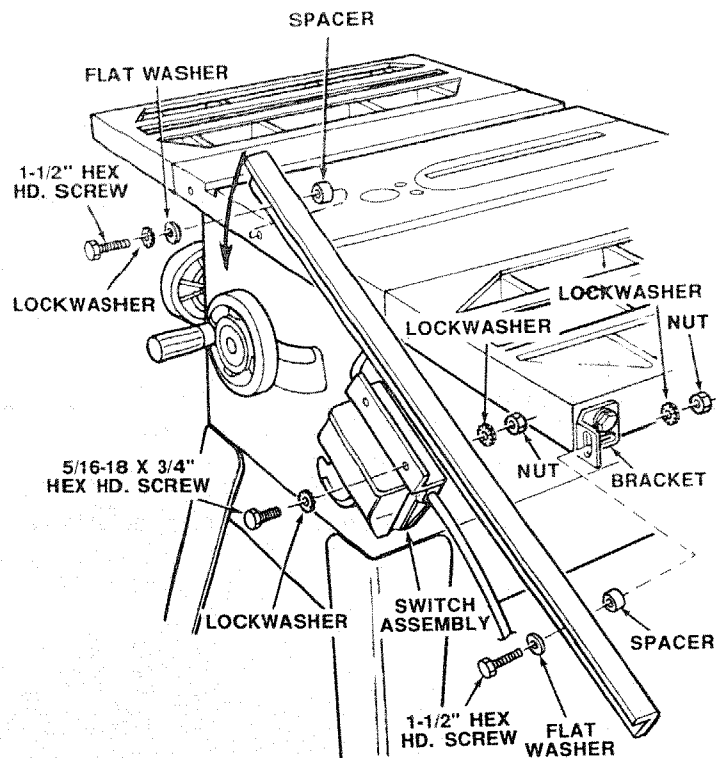

7. Insert one inch long screw and flat washer in FIRST, THIRD and EIGHTH slot of the rear Guide Bar and attach to table and mounting bracket using lockwashers and hex nuts as illustrated. Hand tighten at this time.

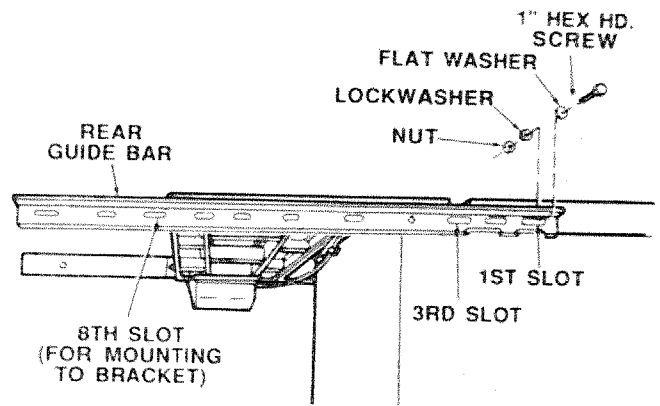

8. Slide the Front Guide Bar as far as it will go to the right and the Rear Guide Bar as far as it will go to the left.
9. Position Rip Fence at left end of Front Guide Bar, holding up the rear end while engaging front end with Front Guide Bar. Lower fence onto table.

NOTE: It may be necessary to loosen Fence Knob to allow Fence to be installed on Rear Guide Bar.

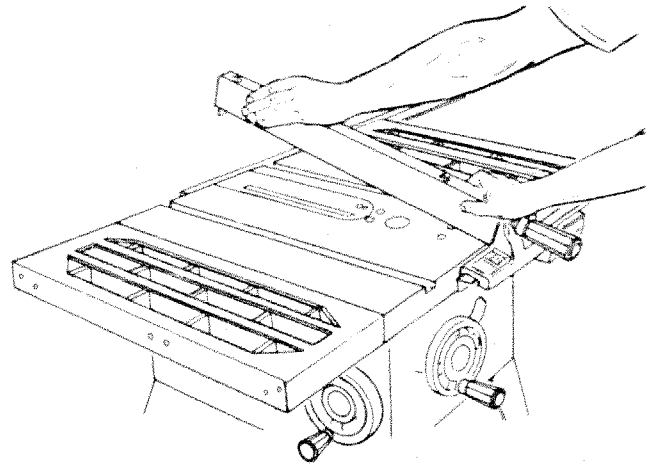

10. Move Front Guide Bar upwards until fence is approximately 1/32 inch above table. Tighten screw at left end of Bar.

NOTE: Fold a piece of newspaper making 8 thicknesses and place between Rip Fence and table to act as a spacer. This will hold the Fence off of the table approximately 1/32 inch.

Adjust Rear Guide Bar so that the Fence is approximately 1/32 inch above table. Tighten screw at end of Bar.

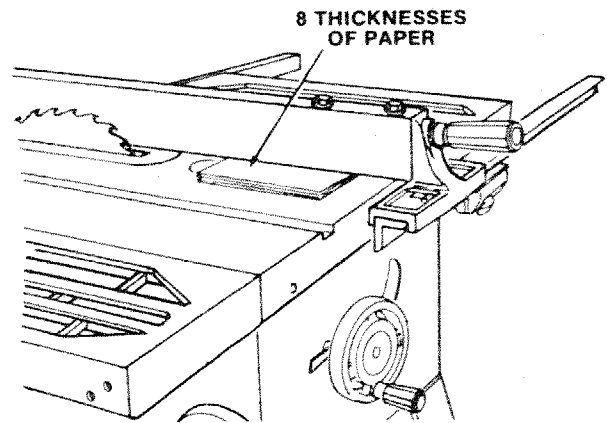

11. Move fence to right edge of table. Make sure it is approximately 1/32 inch above table at front and rear and tighten four remaining screws.

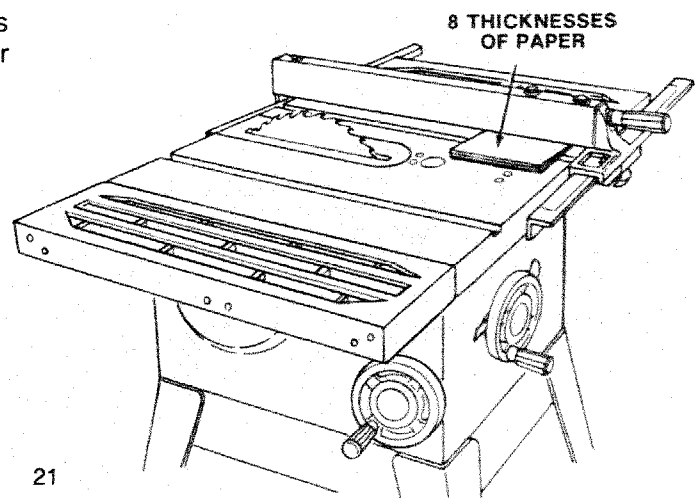

assembly

MODEL 113.298090 ONLY ATTACHING AND ASSEMBLING TABLE EXTENSIONS

1. From among the loose parts, find the following hardware: (Quantity indicated is for 2 extensions.)

- *8 Hex Hd. Screws, 5/16-18 x 1-1/4
- *8 Flat Washers, 21/64 x 5/8 x 1/16
- *8 Lockwashers, External 5/16
- *8 Hex Jam Nut, 5/16-18
- *16 Truss Head Screws, 1/4-20 x 1
- *16 Hex Nut, 1/4-20
- *16 Lockwashers, External 1/4
- *4 Flat Washers, 17/64 x 3/4 x 1/16
- 4 Corner Support Brackets
- 4 Corner Stiffener Brackets
- 2 Brackets

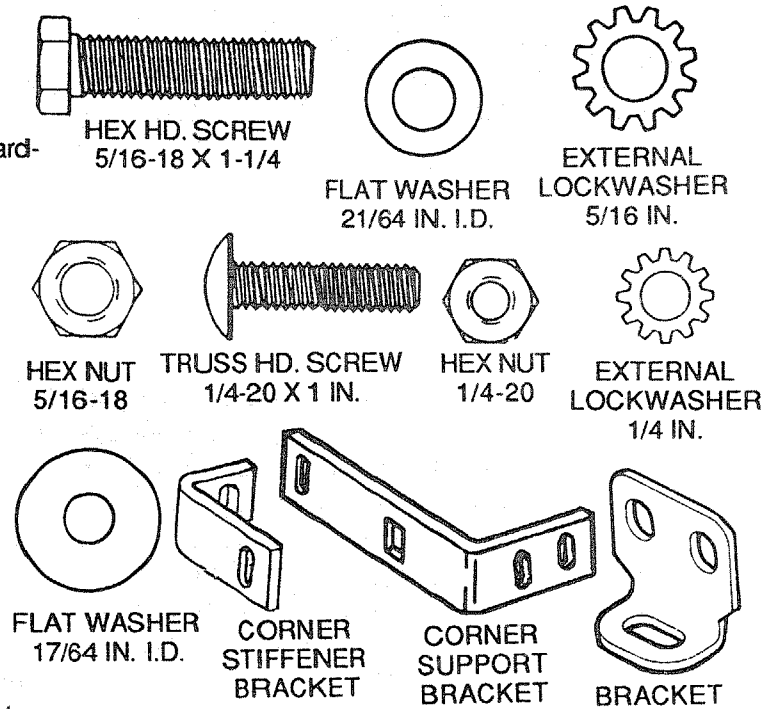

Items marked with an asterisk (*) are shown actual size.

2. Position saw upside down on floor.

NOTE: To protect the finished surfaces of the saw and extensions, lay a piece of heavy paper or cardboard on the floor.

3. Install Corner Support Brackets, Corner Stiffener Brackets, 1/4-20 x 1 inch truss head screws, 17/64 inch flat washers, 1/4 inch external lockwashers, and 1/4-20 hex nuts as shown. Hand tighten only.

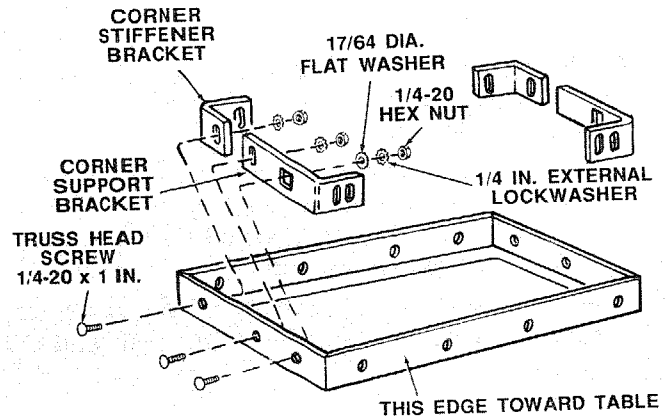

4. Insert four (4) 5/16-18 x 1-1/4 inch hex head screws into holes on inside edge of one extension.
5. Install 11/32 I.D. flat washer, 5/16 external lockwasher, and 5/16-18 hex nut on the end of each screw. Just start nut on end of screw.
6. Slide the extension with hardware into four slots in side of table. LINE UP FRONT EDGE OF EXTENSION WITH FRONT EDGE OF TABLE and tighten all screws and nuts.
7. Repeat for other extension.

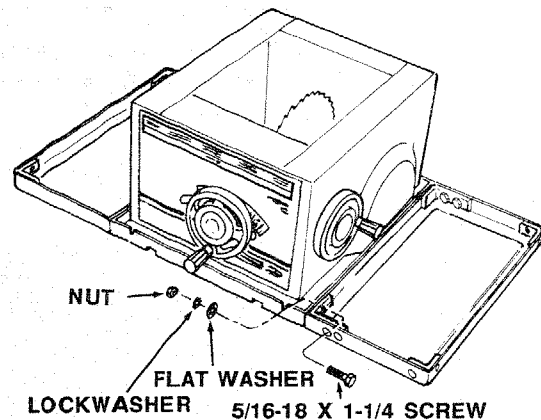

8. Insert a 1/4-20 x 1 truss head screw through bottom hole in the bracket, and through the FIRST hole in the right hand extension. Install a lockwasher and nut on the screw. Hand tighten the nut.
9. Insert a 1/4-20 x 1 truss head screw through bottom hole in the other bracket and the FOURTH hole of the extension. Install a lockwasher and nut on the screw. Hand tighten the nut.
10. Insert the 1/4-20 x 1 truss head screws through the FIRST and FOURTH holes in the left extension without brackets. Install a lockwasher and nut on each screw and hand tighten.

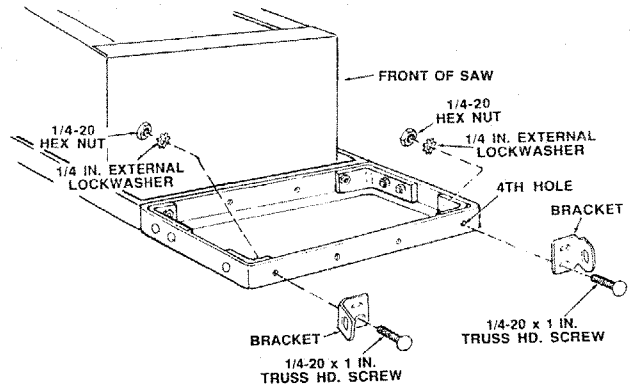

MODEL 113.298090 INSTALLING RIP FENCE GUIDE BARS AND SWITCH BOX

1. From among the loose parts, find the following hardware:
 - *3 Hex Head Screws, 5/16-18 x 1-1/2
 - *3 Hex Head Screws, 5/16-18 x 1
 - *2 Hex Head Screws, 5/16-18 x 3/4
 - *8 Hex Jam Nuts, 5/16-18
 - *4 Flat Washers, 21/64 x 5/8 x 1/16
 - *3 Spacers, 3/4 dia. x 1/2 long
 - *10 Lockwashers, 5/16 External

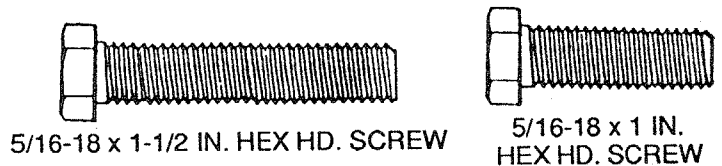

Items marked with an asterisk (*) are shown actual size.

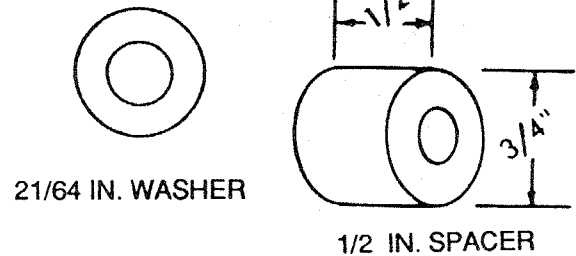

2. Position guide bars on floor and install hardware as shown. Just start the nuts on the end of the screws, DO NOT screw nuts on all the way.

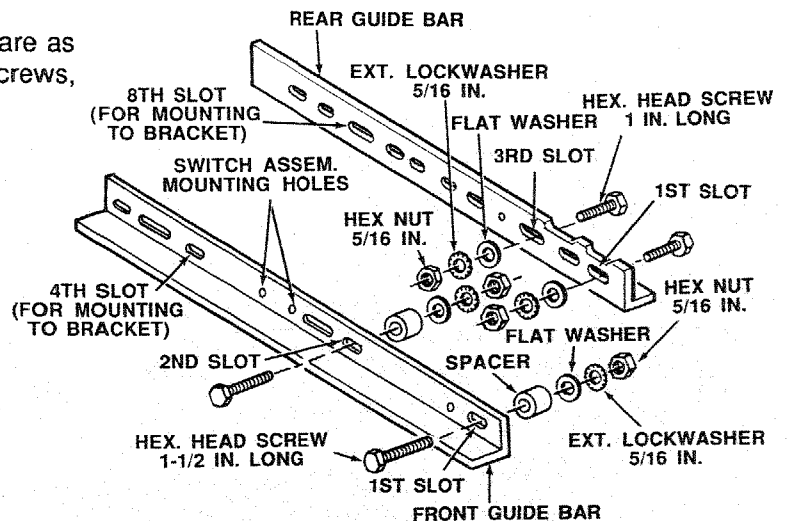

assembly

3. Mount Switch to Guide Bar with two 5/16-18 x 3/4 hex head screws, lockwashers, and nuts. Securely tighten both nuts.

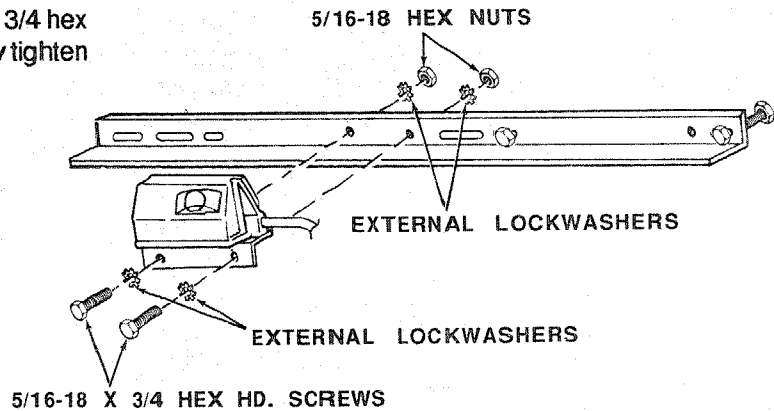

4. Place Front Guide Bar against saw table and drop it in place engaging the screws in the slots. Make sure the spacers are between the rail and the table.
5. End of Front Guide Bar must be 7-5/16 in. from side of saw table. This is important so that Rip Fence Indicator can be aligned.
6. With the blade of your combination square set to 1/4 inch, gauge and adjust guide rail so the edge of the rail is 1/4 inch ABOVE the edge of the table. Securely tighten nuts.
7. Install 5/16-18 x 1-1/2 hex head screw through the FOURTH slot in Front Guide Bar (that lines up with bracket), through the 1/2 inch spacer and the Bracket. Install a 5/16 in. external lockwasher and 5/16-18 hex jam nut.

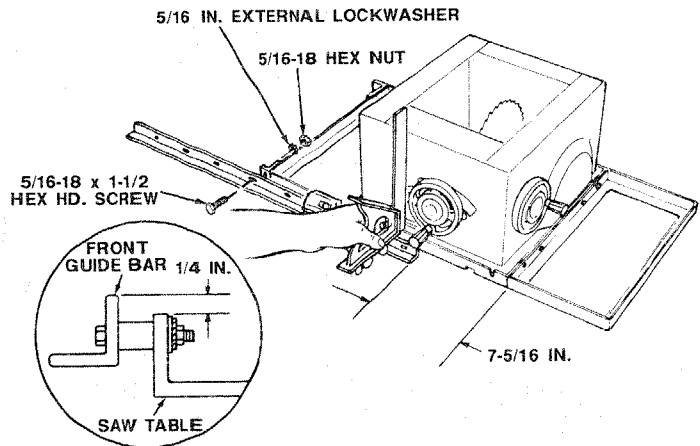

8. Remove the three screws from rear of right table extension.
9. Attach the Rear Guide Bar in a similar manner to the Front Guide Bar. Make sure that the end of the bar is 11 inches from the side of the saw table.
10. Reinstall three truss head screws, lockwashers and hex nuts removed in step 8. Check that all hardware is tight.
11. Insert 5/16-18 x 1 hex head screw through the EIGHTH slot and bracket. Install 5/16 external lockwasher and 5/16 hex jam nut. Tighten securely.

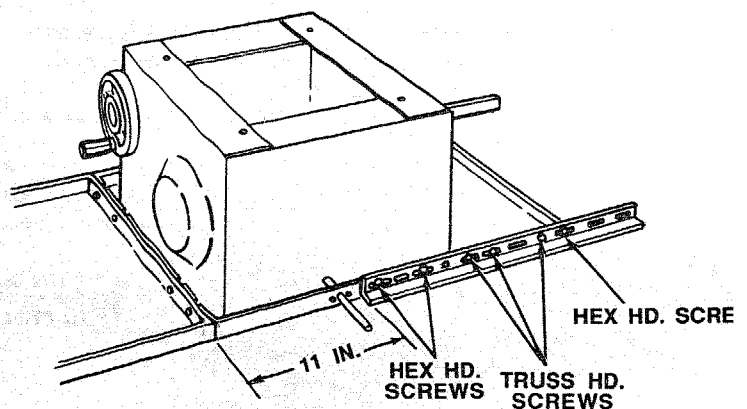

MODEL 113.298090 ONLY
MOUNTING YOUR SAW TO THE LEG SET

1. From among the loose parts, find the following hardware.

- *4 Hex Head Screws, 5/16-18 x 1-1/4
- *4 Hex Nuts, 5/16-18
- *4 Lockwashers, 5/16 In. External
- *8 Flat Washers, 11/32 x 11/16 x 1/16

Items marked with an asterisk (*) are shown actual size.



5/16-18 x 1-1/4
 HEX HEAD SCREW

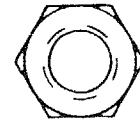

5/16-18 HEX NUT

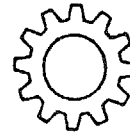

5/16 IN. EXTERNAL
 LOCKWASHER

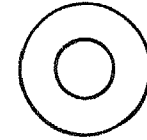

11/32 IN. I.D.
 FLAT WASHER

2. Place the saw on top of the Leg Set so that the base of the saw lines up approximately even with the outline of the top of the Leg Set.
3. From beneath the saw you will be able to locate and line up the four mounting holes of the saw base with the proper mounting holes in the Leg Set assembly.
4. Place one flat washer onto each of the four hex head screws and insert them into each of the mounting holes. Be sure the screws go through the saw base holes and the Leg set mounting holes.

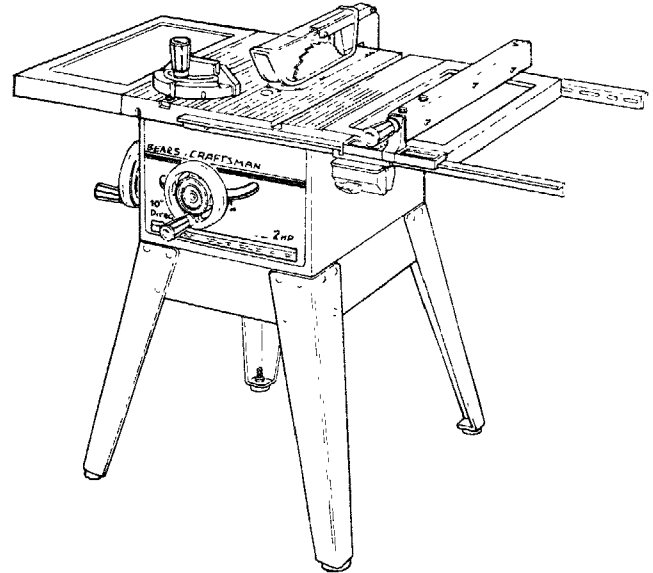

5. Install a flat washer, lockwasher, and a hex nut on each of the four screws and tighten securely.
6. Level the saw to your requirements by adjusting the Leveling Feet. Lock Leveling Feet into position.
7. Securely tighten all Leg Set screws and nuts.

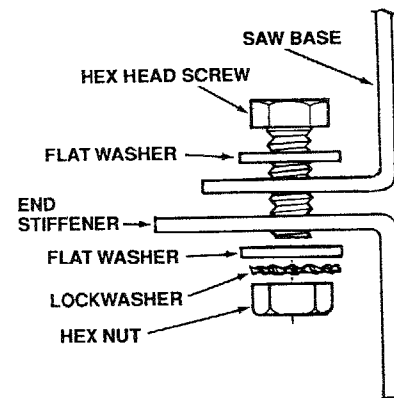

MODEL 113.298090 ONLY
ALIGNING TABLE EXTENSIONS

1. "Tap" extensions upwards or downwards, using a block of wood and a hammer until they are even with the top of the saw table. Be sure end of extensions are even with front edge of saw.

NOTE: If necessary slightly loosen the screws and nuts that connect the extensions to the table.

3. Tighten screws.

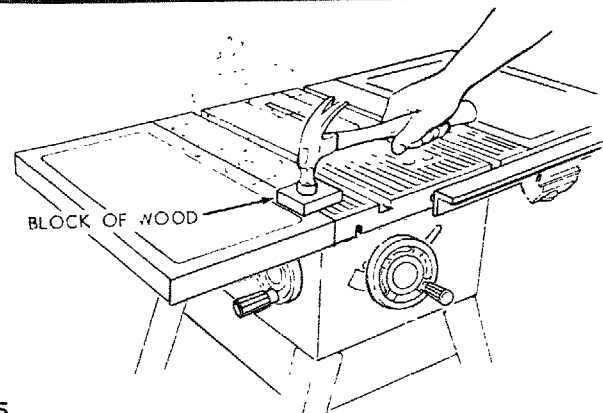

assembly

4. Lay a straight piece of wood or a framing square on table to act as a straightedge. If outer edge of extension is higher or lower than the table surface:
 - A. Slightly loosen nuts holding bracket to extension using $7/16$ in. wrench.
 - B. Move end of extension up or down until outer edge is even with table surface. Check with Guide Bar. Tighten nuts.
 - C. Re-check INNER edge of extension to make sure it has not moved. Readjust, if necessary.

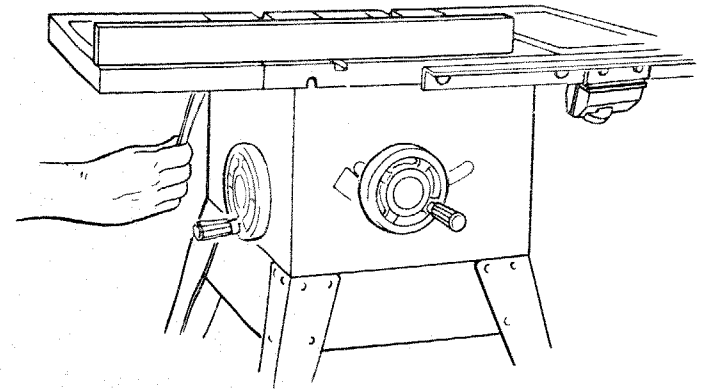

BOTH MODELS

1. From among loose parts, find:
 - 1 Wire Tie

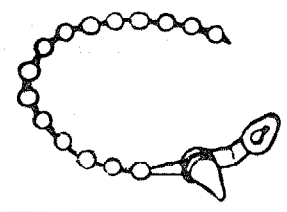

2. Snap wire tie into $1/4$ inch hole in right side of cabinet. Route motor cord from inside cabinet through the wire tie. Secure cord in wire tie. Keep any extra cord on outside of cabinet. Do not push extra cord inside cabinet.

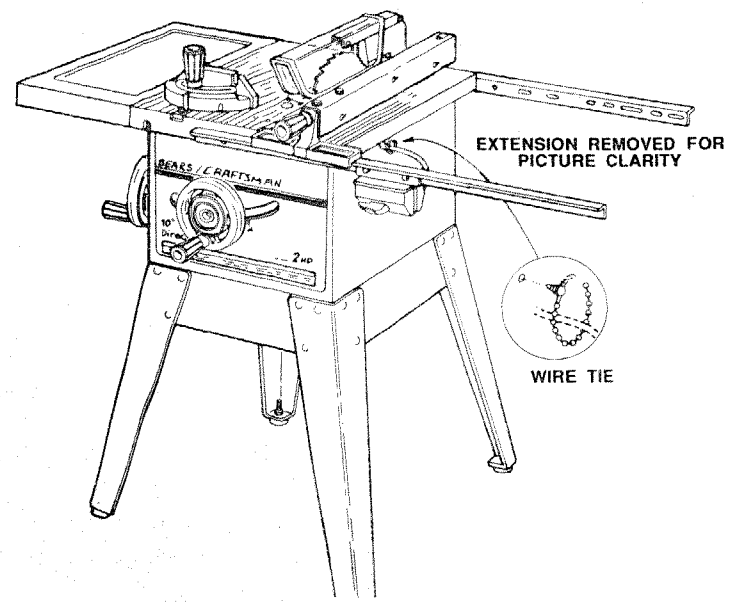

BOTH MODELS MOUNTING YOUR SAW TO A WORKBENCH

To mount the saw on workbench, make sure that there is an opening in the top of the bench the same size as the opening in the bottom of the saw so that the sawdust can drop through. Recommended working height is 33 to 37 inches from the top of the saw table to the floor.

NOTE: All dimensions in inches.

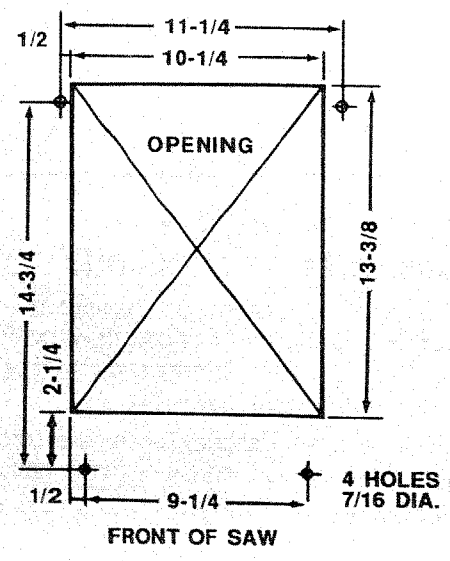

BOTH MODELS

The Fence should slide easily along the Guide Bars and always remain in alignment (parallel to sawblade and Miter Gauge Grooves).

The alignment is maintained by a spring underneath the Fence which bears against the Front Guide Bar.

To move the Fence, loosen the Lock Handle and grasp the Fence with one hand at the front.

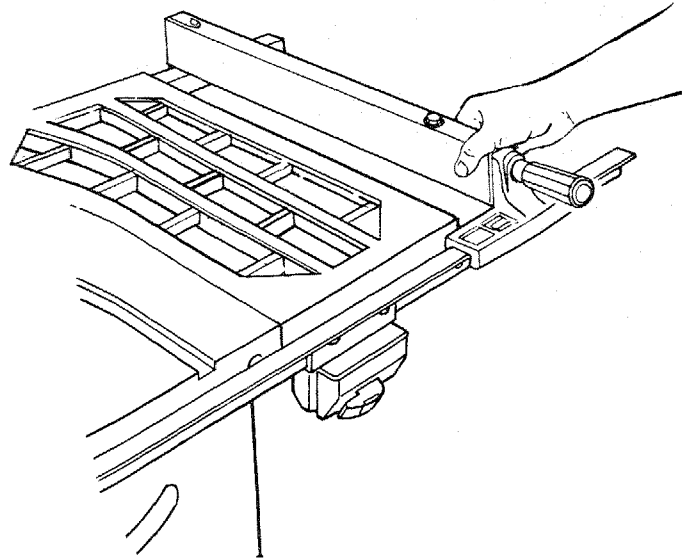

For very close adjustments, grasp the Guide Bar with both hands and move the Fence with your thumbs.

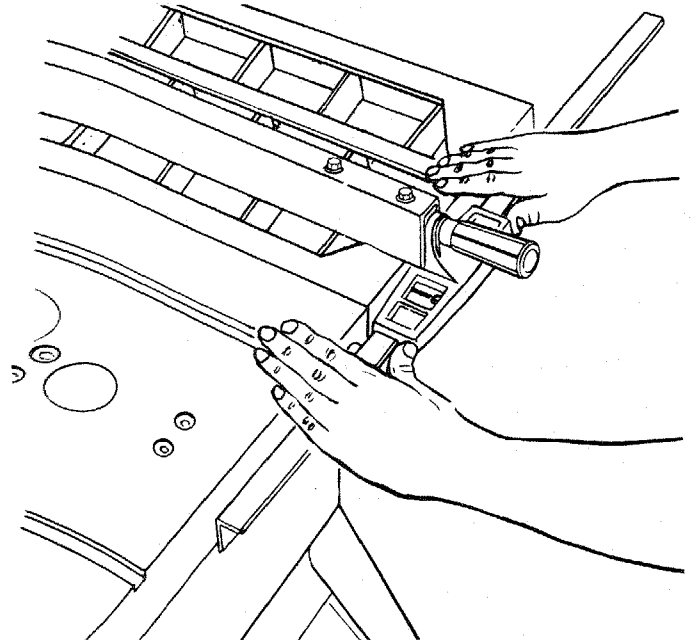

BOTH MODELS SELF-ALIGNING SPRING ADJUSTMENT

Place Fence on saw but DO NOT LOCK IT.

Move the REAR END of the Fence slightly to the right of left. When you release it, the Fence should "spring" back to its original position.

If it does not, the spring pressure must be INCREASED.

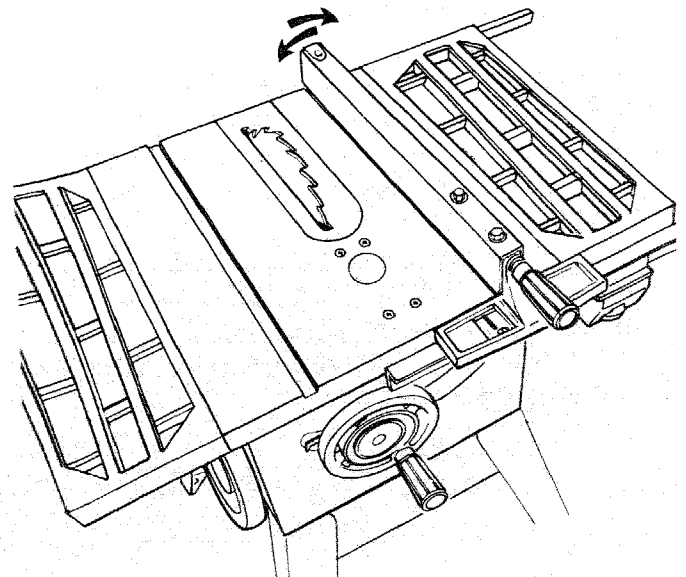

assembly

1. Loosen the screws.
2. Move spring slightly toward front of Fence. Tighten screws.

If the Fence does not slide easily along the Bars, the pressure of the spring can be REDUCED.

1. Loosen the screws.
2. Move spring slightly toward rear of Fence. Tighten screws.

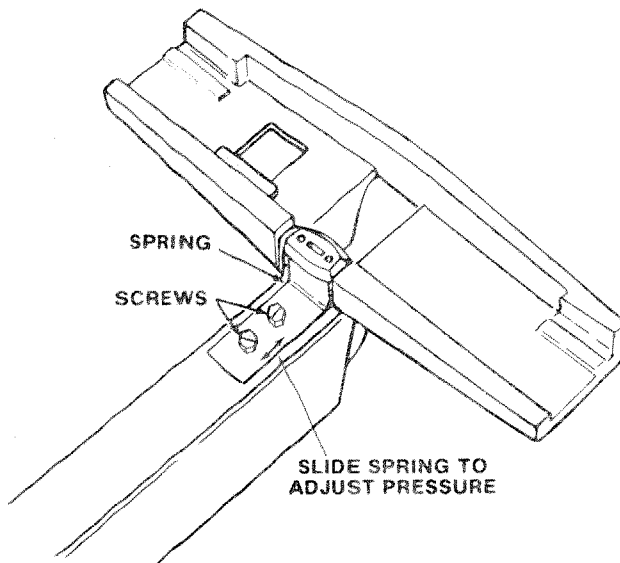

RIP FENCE ALIGNMENT ADJUSTMENT

WARNING: A misaligned Rip Fence can cause kickbacks and jams. To avoid injury, follow these instructions until the fence is properly aligned.

The Rip Fence must be PARALLEL with the sawblade and Miter Gauge Grooves. Move Fence until it is along side of Groove. DO NOT LOCK IT. It should be parallel to Groove. If it is not:

1. Loosen the Hex Head screws.
2. Hold Fence head tightly against Bar. Move end of Fence so that it is parallel with Groove.
3. Alternately tighten the screws.
4. Re-check alignment.
5. Repeat steps, as needed.

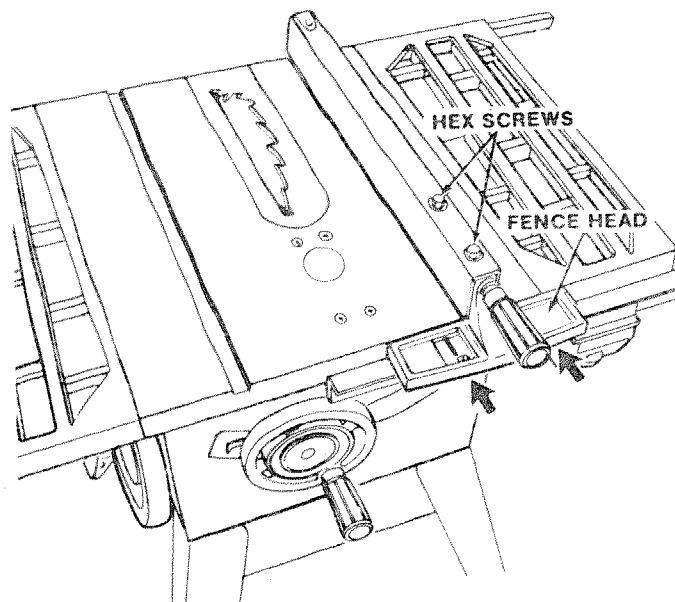

ADJUSTING RIP SCALE INDICATOR

1. Turn Elevation Handwheel clockwise until blade is up as high as it will go.

IMPORTANT: BLADE must be SQUARE (90°) to TABLE, in order to ALIGN Rip Fence.

2. Using a rule, position Fence on right side of sawblade 2 inches from the side of the teeth, tighten Lock Handle.
3. Loosen screw holding the Indicator, adjust so that it points to "2" on the Rip Scale, tighten screw.

NOTE: If you cannot adjust Indicator so that it points to "2," loosen the screws holding the Front Guide Bar and move the Guide Bar.

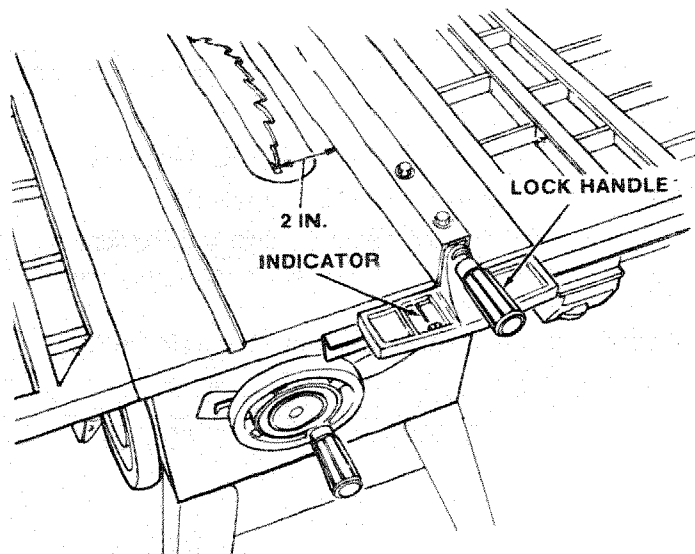

BOTH MODELS INSTALLING BLADE GUARD

1. From among the loose parts, find the following hardware:

- *2 Truss Head Screws, 1/4-20 x 5/8
- *2 Socket Head Setscrew, 1/4-20 x 7/8
- *4 Flat Washer, 17/64 x 9/16 x 3/64
- *2 Hex Nuts, 1/4-20
- *4 Lockwashers, 1/4 External
- *2 Wing Nuts, 1/4-20
- *2 Square Nuts, 1/4-20
- 1 Spreader Support
- 1 Spreader Bracket
- 1 Spreader Clamp

Items marked with an asterisk (*) are shown actual size.

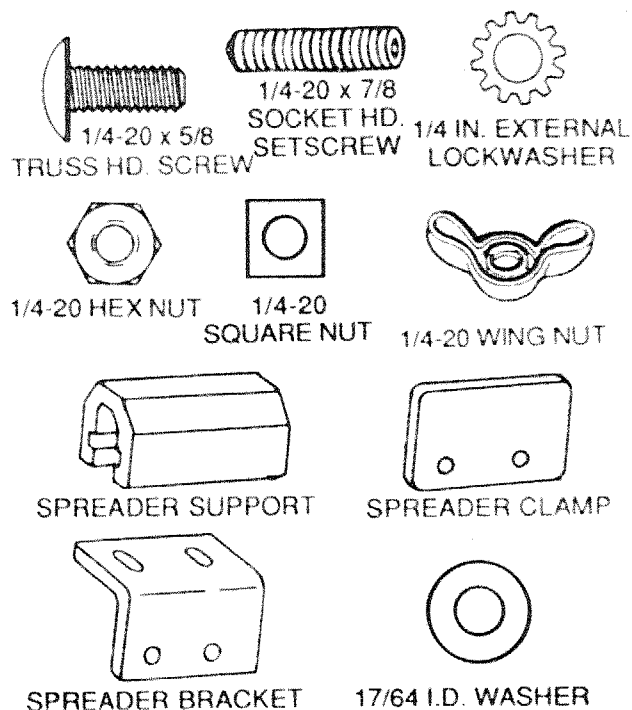

2. Make sure blade is all the way up and square with table.
3. Position Spreader Support on Rod until it is even with the end of the Rod.

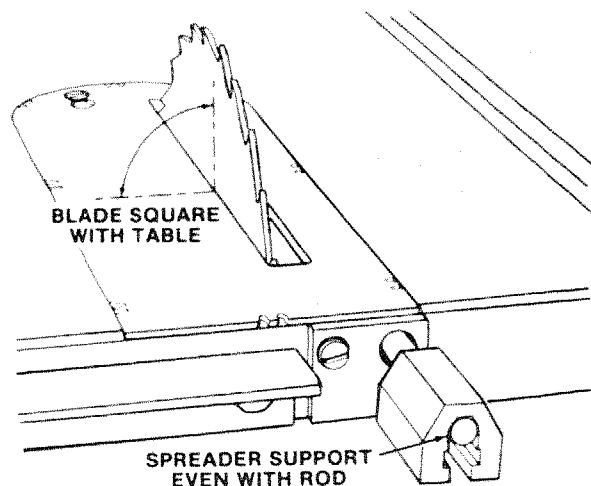

4. Assemble the 7/8 inch long setscrews, nuts, lockwashers and washers to the Spreader Support Bracket and slip the nuts into the slot in the Spreader Support.

5. Finger tighten only the hex nuts.

NOTE: Be sure to put the socket head setscrew through the slot shaped holes in the Spreader Bracket (see illustration). This allows the Guard and Spreader to be lined up with the blade. Be sure the socket end of the setscrew is at the hex nut end of the assembly.

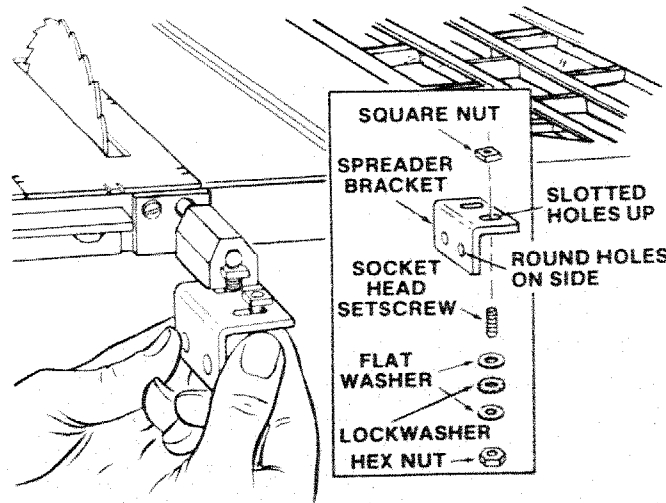

assembly

6. Lay a piece of flat straight wood and a square on saw table and rotate the Spreader Support until the Bracket is aligned with square.
7. Make sure end of Support, Bracket and Rod are even. Using a 1/8 inch hex "L" wrench, tighten the setscrews only. Check that the Spreader Support cannot be rotated on the Spreader Rod.

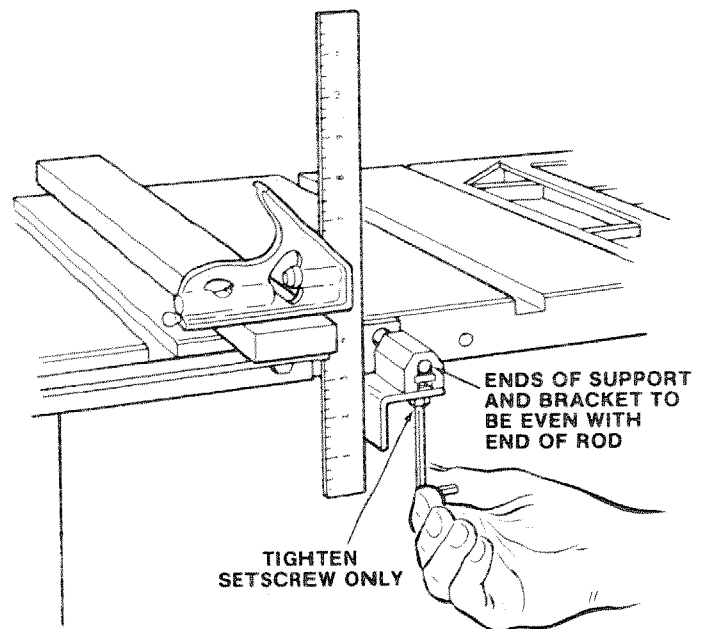

IMPORTANT: To work properly, the spreader must always be parallel to the sawblade and adjusted so the cut workpiece will pass on either side of the Spreader without binding or skewing to the side.

NOTE: The Spreader is thinner than the width of the KERF by approximately six thicknesses of paper.

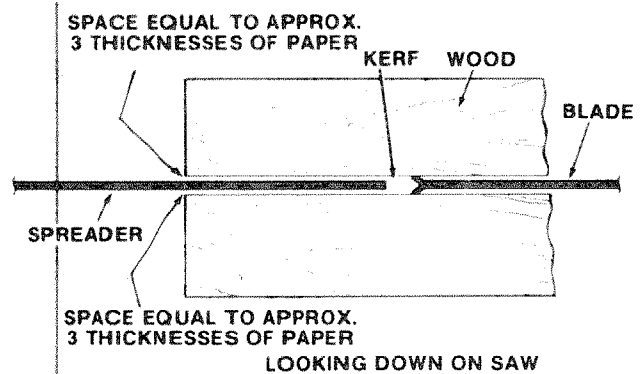

8. Make two folds in a small piece (6 x 6 in.) of ordinary newspaper making three thicknesses. The folded paper will be used as a "spacing gauge".

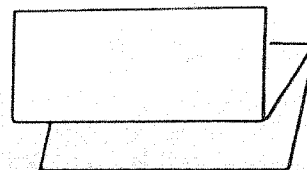

9. Raise blade to maximum height and make sure blade is square to the saw table.
10. Install the Spreader Clamp using 1/4-20 x 5/8 truss head screws, lockwashers, and wing nuts. Place Spreader between Spreader Clamp and Bracket. Move Spreader forward until all three are in line. Tighten Wing screws.
11. Lift up both Anti-Kickback Pawls. Insert setscrew wrench or a pencil into notches to hold the Pawls out of the way.
12. Lay a piece of straight flat wood against the saw blade. Insert folded paper between Spreader and strip of wood.
13. MAKE SURE THE HEX NUTS UNDERNEATH ARE LOOSE.
14. Hold the Spreader tightly against the wood and make sure the wood is against the saw blade. Tighten the hex nuts.
This will align the Spreader in the middle of the cut (KERF) made by sawblade.

NOTE: To remove the Guard for non-through cuts, loosen the Wing Nuts and slide the Guard back and upward off the Spreader Bracket. DO NOT DISTURB THE SETTING OF THE SPREADER BRACKET.

When replacing the Guard, slide the Spreader down and forward between the Spreader Clamp and Spreader Bracket until it rests as shown. Make sure Wing Nuts are tightened securely. this lets you remove and replace the Guard without disturbing the Spreader alignment.

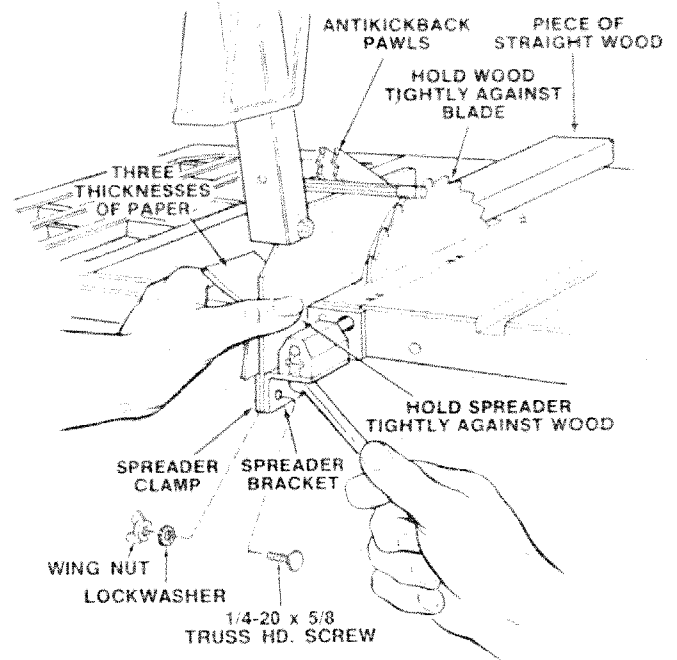

BOTH MODELS

ADJUSTING MITER GAUGE

MITER GAUGE

NOTE: The graduations are manufactured to very close tolerances which provide suitable accuracy for average woodworking. In some cases where extreme accuracy is required, make a trial cut and then re-check it with an accurate square or protractor. If necessary, the Miter Gauge head can then be swiveled slightly to compensate and then locked.

The HEAD should be SQUARE (90°) with the bar when the pointer points to "0".

To check for squareness, place an accurate square on the Miter Gauge. If the head is NOT SQUARE with the bar:

1. Loosen the Lock Knob.
2. Position the head square with the bar. Tighten the Lock Knob.
3. Loosen the screw and adjust the pointer, so it points to zero.

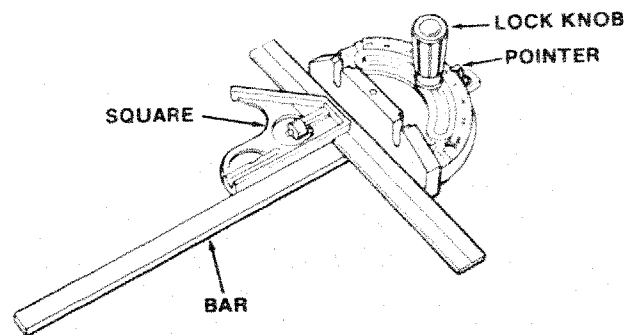

The swiveling movement of the head can be adjusted by tightening or loosening the set screw located inside of the head using a 1/8 in. hex "L" wrench.

getting to know your saw

BOTH MODELS

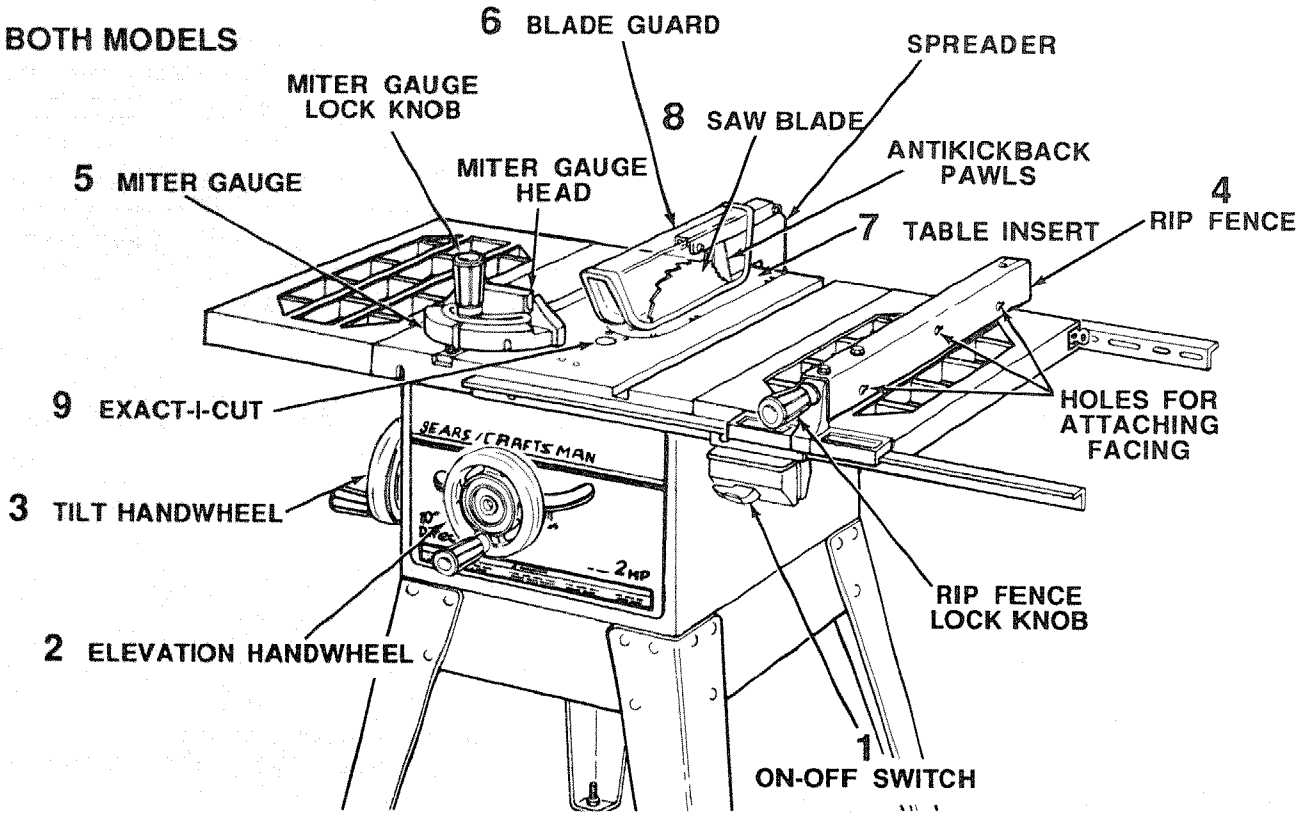

1 ON-OFF SWITCH

CAUTION: Before turning switch "ON", make sure the blade guard is correctly installed and operating properly.

The On-Off Switch has a locking feature. THIS FEATURE IS INTENDED TO PREVENT UN-AUTHORIZED AND POSSIBLE HAZARDOUS USE BY CHILDREN AND OTHERS.

A. Insert key into switch.

B. To turn saw ON, stand to either side of the blade, never in line with it, insert finger under switch lever and pull END of lever out.

After turning switch ON, always allow the blade to come up to full speed before cutting.

Do not cycle the Motor Switch on and off rapidly, as this may cause the sawblade to loosen. In the event this should ever occur, allow the sawblade to come to a complete stop and re-tighten the arbor nut normally, not excessively. Never leave the saw while the power is "ON".

C. To turn saw OFF, PUSH lever in. Never leave the saw until the cutting tool has come to a complete stop.

D. To lock switch in OFF position, hold switch IN with one hand, REMOVE key with other hand.

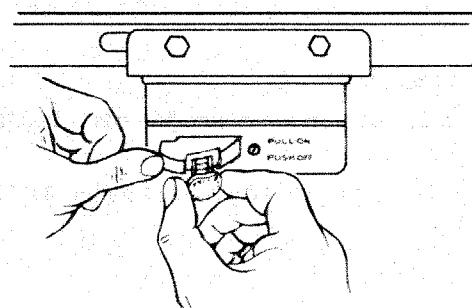
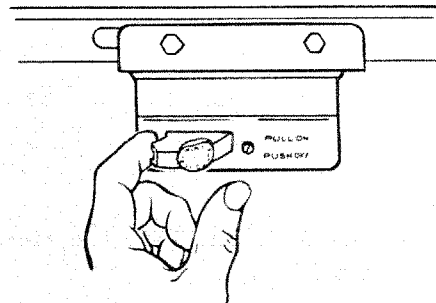
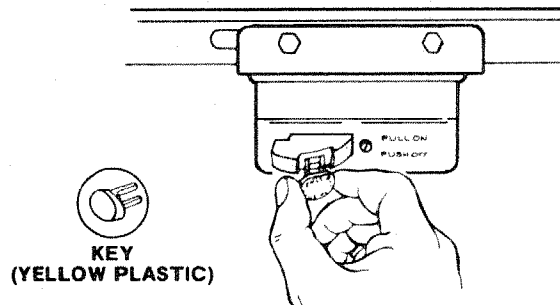

WARNING: For your own safety, lower blade or other cutting tool below table surface. (If blade is tilted, return it to vertical, 90°, position). Always lock the switch "OFF". When saw is not in use, remove key and keep it in a safe place. Also, in the event of a power failure (all of your lights go out) turn switch off, lock it by removing the key. This will prevent the saw from starting up again when the power comes back on.

2 ELEVATION HANDWHEEL . . . elevates or lowers the blade. Turn clockwise to elevate, counterclockwise to lower.

3 TILT HANDWHEEL . . . tilts the blade for bevel cutting. Turn clockwise to tilt toward left, counterclockwise to tilt toward right.

When the blade is tilted to the LEFT as far as it will go, it should be at 45° to the table and the bevel indicator should point to 45°.

NOTE: There are LIMIT STOPS inside the saw which prevent the blade from tilting beyond 45° to the LEFT and 90° to the RIGHT. (See "ADJUSTMENTS AND ALIGNMENTS" section "BLADE TILT, OR SQUARENESS OF BLADE TO TABLE").

4 RIP FENCE . . . is locked in place by tightening the Lock Knob. To move the Fence, loosen the Knob and grasp the Fence with one hand at the front.

Holes are provided in the Rip Fence for attaching a wood facing when using the Dado Head, or Molding Head.

Select a piece of smooth straight wood approximately 3/4 inch thick, at least as long as the Rip Fence, and at least 7-1/2 inches wide (high) to permit clamping of Featherboards.

Attach it to the Fence with three Round Head #10 Wood Screws, 2 inches long. To remove the facing, loosen the screws, slide the facing forward and pull the screws through the round holes.

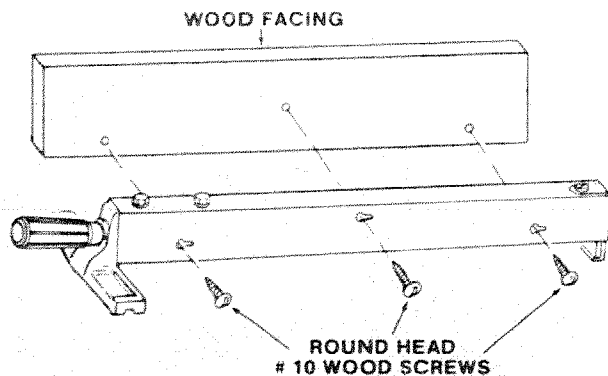

MODEL 113.298090

If you are making a rip type cut in material thinner than 3/16 inch while the Fence is positioned over the depressed area of Table Extension, the facing should be attached to the Fence so that the bottom edge

touches the top surface of the Extension. In this case, the facing must be shorter than the Fence. This will prevent thin material from sliding under the Rip Fence.

5 MITER GAUGE . . . head is locked in position for crosscutting or mitering by tightening the Lock Knob. ALWAYS LOCK IT SECURELY WHEN IN USE.

Slots are provided in the Miter Gauge for attaching an Auxiliary Facing to make it easier to cut long pieces. Be positive Facing does not interfere with the proper operation of the Sawblade Guard.

Select a suitable piece of smooth straight wood, drill two holes through it and attach it with screws.

NOTE: When bevel crosscutting, attach Facing so that it extends to the right of the Miter Gauge and use the Miter Gauge in the groove to the right of the blade.

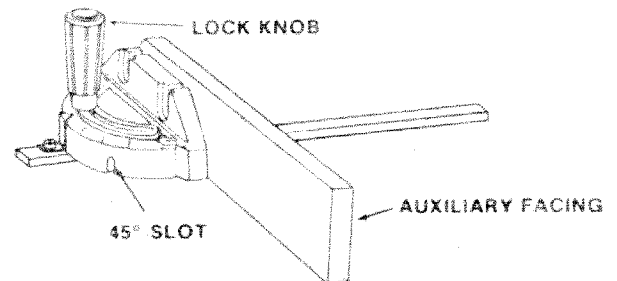

6 BLADEGUARD . . . must always be in place and working properly for all thru-sawing cuts. That is, all cuts whereby the blade cuts completely through the workpiece.

To remove the Guard for special operations, loosen the Wing Nuts and slide the Guard back and upward off the Spreader Bracket. DO NOT DISTURB THE SETTING OF THE SPREADER BRACKET.

When replacing the Guard, slide the Spreader down and forward between the Spreader Clamp and Spreader Bracket until the bottom and rear edges of all three are even. Make sure both Wing Nuts are hand tightened securely.

7 TABLE INSERT . . . is removable for removing or installing blades or other cutting tools.

WARNING: To avoid injury due to accidental start, turn switch "OFF" and remove plug from power source outlet before removing insert.

- A. Lower the blade below the table surface.
- B. Raise Blade Guard.
- C. Loosen screw.
- D. Lift insert from front end, and pull toward front of saw.

NEVER OPERATE THE SAW WITHOUT THE PROPER INSERT IN PLACE. Use the saw blade insert when using a saw blade. Use the combination Dado/Molding insert when using a Dado or Molding head.



basic saw operations

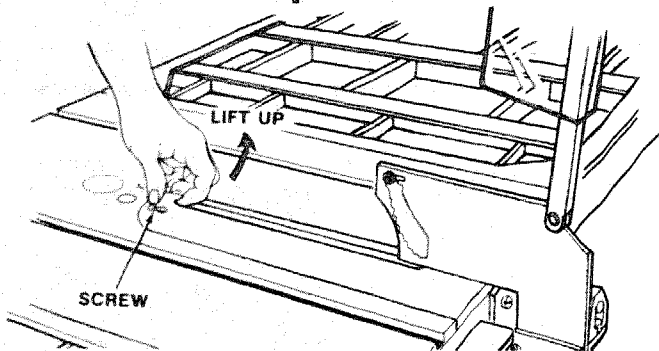

8 REMOVING AND INSTALLING SAWBLADE

WARNING: To avoid injury due to accidental start, push switch "OFF" and remove plug from power source outlet before removing or installing sawblade.

- Remove Insert.
- Place open end Arbor Wrench on flat surfaces of saw arbor and closed end Arbor Wrench on nut. Position wrenches as shown, holding your hands well above blade.
- With Arbor Wrench against table, PULL wrench on arbor nut forward to LOOSEN nut.
- To TIGHTEN nut, hold Arbor Wrench against rear of table, push arbor nut wrench toward rear.

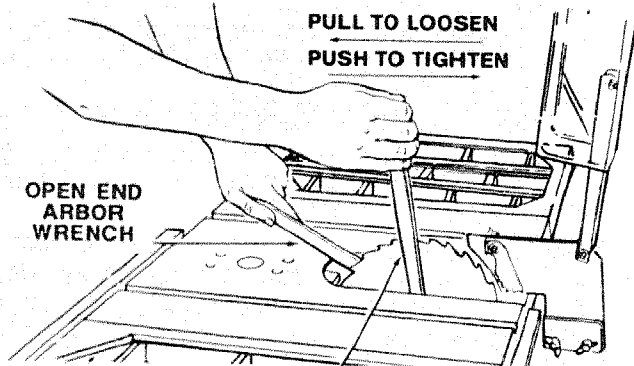

CLOSED END ARBOR NUT WRENCH

NOTE: When installing the blade, make sure the teeth are pointing toward the front of the saw and that the blade and collars are clean, and free from any burrs.

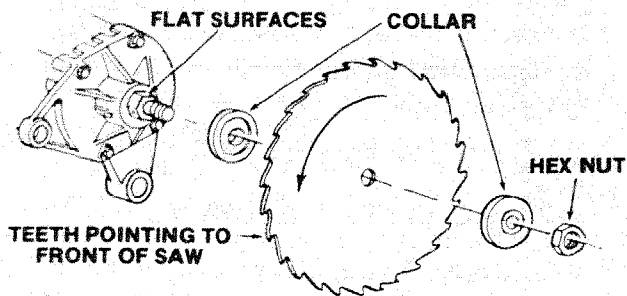

The HOLLOW side of the collar must be against the blade.

- To replace insert. Place insert into opening in table and push toward rear of saw to engage Spring Clip and until key slot in insert will drop over screw. Tighten screw.

Do not tighten screw to the point where it will deflect the insert.

9 EXACT-I-CUT

The "yellow" Plastic Disc imbedded in the table in front of the sawblade, is provided for marking the location of the "sawcut" on the workpiece.

- Check Disc. If it is above table surface, place a piece of hardwood on top of it and tap it down.
- With blade 90° (square to table) cut off a piece of wood.
- Pull Miter Gauge back until wood is over Disc. Using very sharp pencil, mark a line on Disc.
- With Miter Gauge in right hand groove, follow same procedure and mark another line on Disc.
- These lines indicate the "path" of the cut (kerf) made by the sawblade.
- When cutting the workpiece, line up mark on workpiece with line on Disc.

Use the Hold-Down Clamp (optional accessory) on the Miter Gauge for greater accuracy.

SHOWN WITH HOLD-DOWN CLAMP (OPTIONAL ACCESSORY)

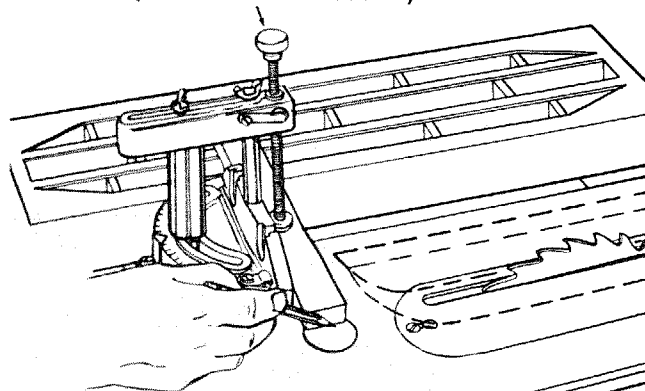

BLADE GUARD SHOWN IN "PHANTOM" FOR PICTURE CLARITY

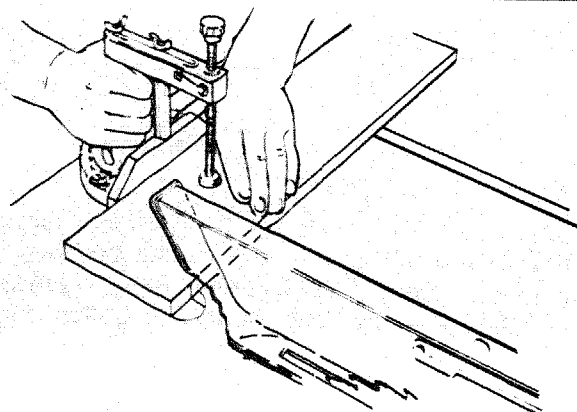

**BOTH MODELS
WORK HELPERS**

Before cutting any wood on your saw, study all of the "Basic Saw Operations."

Notice that in order to make some of the cuts, it is necessary to use certain devices, "Work Helpers", like the Push Stick, the Push Block and the Auxiliary Fence/Work Support, which you can make yourself.

After you have made a few practice cuts, make up these "helpers" before starting any projects. Make the "Push Stick" first.

PUSH STICK AND PUSH BLOCK

Make the Push Stick using a piece of 1 x 2.

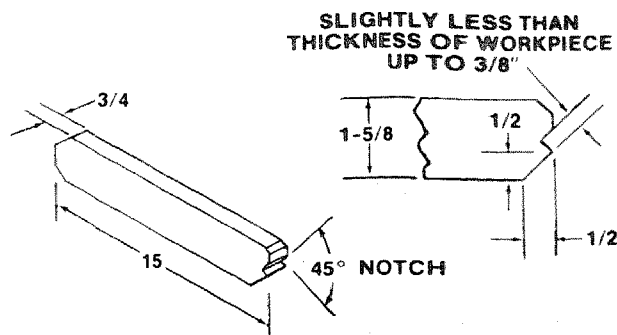

NOTE: All dimensions in inches

PUSH STICK

Make the Push Block using a piece of 3/8 in. and 3/4 in. plywood.

The small piece of wood 3/8 x 3/8 x 2-1/2 inches should be GLUED to the plywood. DO NOT USE NAILS. This is to prevent dulling the sawblade in the event you mistakenly cut into the Push Block.

Position the handle in the center of the plywood and fasten together with glue and wood screw.

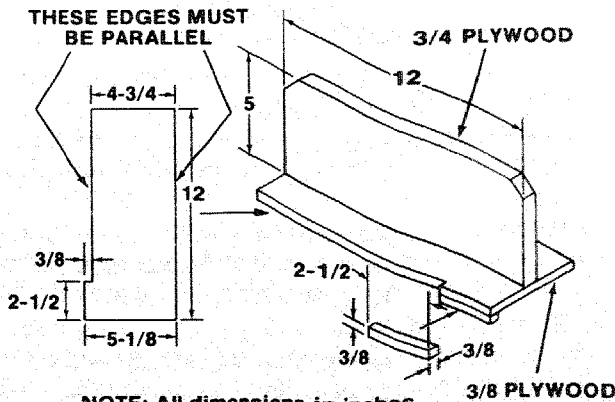

NOTE: All dimensions in inches

PUSH BLOCK

AUXILIARY FENCE/WORK SUPPORT

Make one using a piece of 3/8 inch and 3/4 inch plywood. Fasten together with glue and wood screws.

NOTE: Since the Push Block is used with the Auxiliary Fence, the 4-3/4 inches dimensions must be held identical on both the pieces.

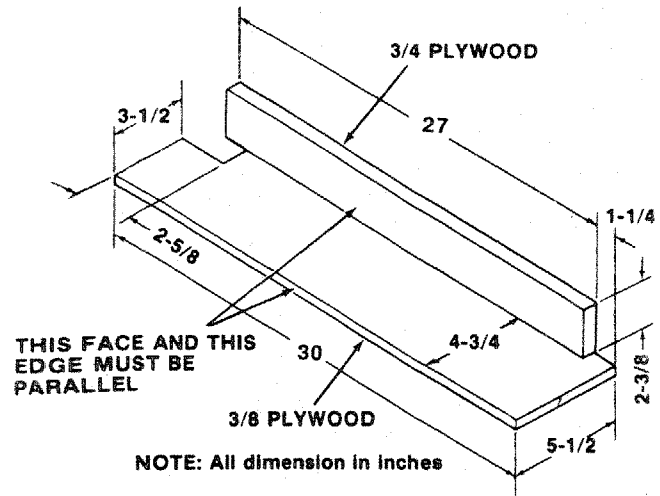

NOTE: All dimension in inches

**MODEL 113.298060
AUXILIARY FENCE/WORK SUPPORT**

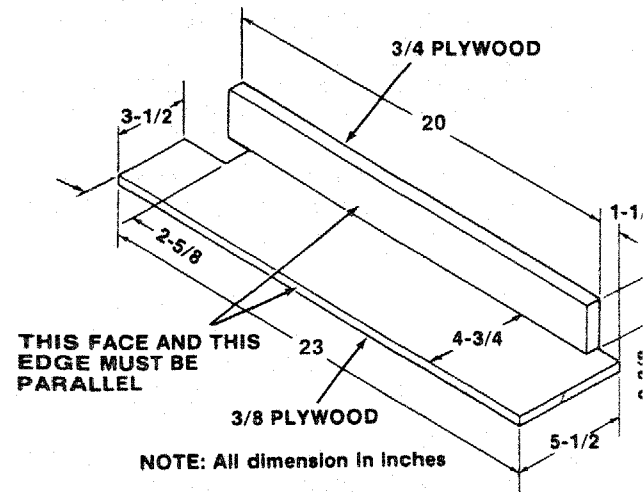

NOTE: All dimension in inches

**MODEL 113.226880
AUXILIARY FENCE/WORK SUPPORT**



safety instructions for basic saw operations

BOTH MODELS

BEFORE EACH USE:

1. Inspect your saw

- A. To avoid injury from accidental starting, unplug the saw, turn the switch off and remove the Switch Key before raising or removing the Guard, changing the cutting tool, changing the setup or adjusting anything.
- B. Check for alignment of moving parts, binding of moving parts, breakage of parts, saw stability, and any other conditions that may affect the way the saw works. If any part is missing, bent, or broken in any way, or any electrical part does not work properly, turn the saw off and unplug the saw.
- C. Replace damaged, missing, or failed parts before using the saw again.
- D. Use the Sawblade Guard, Spreader, and Anti-Kickback Pawls for any thru-sawing (whenever the blade comes through the top of the workpiece). Make sure the Pawls work properly. Make sure the Spreader is in line with the sawblade.
- E. REMOVE ADJUSTING KEYS AND WRENCHES. Form habit of checking for and removing keys and adjusting wrenches from tool before turning it on.
- F. To avoid injury from jams, slips or thrown pieces (kickback and throwback):
 1. USE ONLY RECOMMENDED ACCESSORIES (See page 47). Follow the instructions that come with the accessories. Using other accessories may be dangerous.
 2. Choose the right blade or cutting accessory for the material and the type of cutting you plan to do.
 3. Never use grinding wheels, abrasive cut-off wheels, friction wheels (metal slitting blades) wire wheels or buffing wheels. They can fly apart explosively.
 4. Choose and inspect your cutting tool carefully.
 - a. To avoid cutting tool failure and thrown shrapnel (broken pieces of blade), use only 10" or smaller blades or other cutting tools marked for speeds of 3450 rpm or higher.
 - b. Always use unbroken, balanced blades designed to fit this saw's 5/8 inch arbor.
 - c. When thru-sawing (making cuts where the blade comes through the workpiece top), always use a 10 inch diameter blade. This keeps the Spreader in closest to the blade.
 - d. Do not over tighten arbor nut. Use arbor wrenches to "snug" it securely.
 - e. Use only sharp blades with properly set teeth. Consult a professional blade sharpener when in doubt.
 - f. Keep blades clean of gum and resin.
5. Adjust table inserts flush with the table top. NEVER use the saw without the proper insert.
6. Make sure all clamps and locks are tight and no parts have any excessive play.

2. Keep work area clean

- A. Cluttered areas and benches invite accidents. Floor must not be slippery from wax or sawdust.
- B. To avoid burns or other fire damage, never use the saw near flammable liquids, vapors or gases

3. Plan your work - plan ahead to protect your eyes, hands, face, ears.

WARNING: To avoid injury, don't do layout, assembly, or setup work on the table while the blade is spinning. It could cut or throw anything hitting the blade.

- A. USE THE RIGHT TOOL - Don't force tool or attachment to do a job it was not designed for.

B. Dress for safety:

1. **Do not wear** loose clothing, gloves, neckties or jewelry (rings, wristwatches). They can get caught and draw you into moving parts.
2. Wear non-slip footwear.
3. Tie back long hair.
4. Roll long sleeves above the elbow.
5. Noise levels vary widely. To avoid possible hearing damage, wear ear plugs or muffs when using saw for long periods of time.
6. Any power saw can throw foreign objects into the eyes. This can cause permanent eye damage. Wear safety goggles (not glasses) that comply with ANSI Z87.1 (shown on package). Everyday eyeglasses have only impact resistant lenses. They are not safety glasses. Safety goggles are available at Sears retail catalog stores. Glasses or goggles not in compliance with ANSI Z87.1 could seriously hurt you when they break.



7. For dusty operations, wear a dust mask along with the safety goggles.
- C. Inspect your workpiece. Make sure there are no nails or foreign objects in the part of the workpiece to be cut.
 - D. Plan your cut to avoid **KICKBACKS** and **THROWBACKS** - when a part or all of the workpiece binds on the blade and is thrown violently back toward the front of the saw.
 1. Inspect your workpiece. Make sure there are no nails or foreign objects in the part of the workpiece to be cut.
 2. **Never cut FREEHAND:** Always use either a Rip Fence, Miter Gauge or fixture to position and guide the work, so it won't twist, bind on the blade and kickback.

3. Make sure there's no debris between the workpiece and its supports.
4. When cutting **irregularly shaped workpieces**, plan your work so it will not slip and pinch the blade:

- a. A piece of molding, for example, must lie flat or be held by a fixture or jig that will not let it twist, rock or slip while being cut. Use jigs or fixtures where needed to prevent workpiece shifting.
- b. Use a different, better suited type of tool for work that can't be made stable.

5. Use extra caution with large, very small or awkward workpieces:

- a. Use extra supports (tables, saw horses, blocks, etc.) for any workpieces large enough to tip when not held down to the table top. **NEVER use another person** as a substitute for a Table Extension, or as additional support for a workpiece that is longer or wider than the basic saw table, or to help feed, support or pull the workpiece.
- b. Never confine the piece being cut off. That is, the piece NOT against the Fence, Miter Gauge or fixture. Never hold it, clamp it, touch it, or use length stops against it. It must be free to move. If confined, it could get wedged against the blade and cause a kickback or throwback.
- c. Never cut more than one workpiece at a time.
- d. **NEVER** turn the saw "ON" before clearing the table or all tools, wood scraps, etc., except the workpiece and related feed or support devices for the cut planned.

4. Plan the way you will push the workpiece through

- A. **NEVER** pull the workpiece through. Start and finish the cut from the front of the table saw.
- B. **NEVER** put your fingers or hands in the path of the sawblade or other cutting tool.
- C. **NEVER** reach in back of the cutting tool with either hand to hold-down or support the workpiece, remove wood scraps, or for any other reason.
- D. Avoid awkward operations and hand positions where a sudden slip could cause fingers or hand to move into a sawblade or other cutting tool.
- E. **DON'T OVERREACH.** Always keep good footing and balance.
- F. Push the workpiece against the rotation of the blade. **NEVER** feed material into the cutting tool from the rear of the saw.
- G. Always push the workpiece all the way past the sawblade.
- H. As much as possible, keep your face and body to one side of the sawblade, out of line with a possible kickback or throwback.

- I. **NEVER** turn the saw "ON" before clearing the table of all tools, wood scraps, etc., except the workpiece and related feed or support devices for the cut planned.

- J. **AVOID ACCIDENTAL STARTING** - Make sure switch is "OFF" before plugging saw in.

WHENEVER SAW BLADE IS SPINNING

WARNING: Don't let familiarity (gained from frequent use of your table saw) cause a careless mistake. Always remember that a careless fraction of a second is enough to cause a severe injury.

1. Before actually cutting with the saw, watch it while runs for a short while. If it makes an unfamiliar noise or vibrates a lot, stop immediately. Turn the saw off. Unplug the saw. Do not restart until finding and fixing the problem.
2. Make sure the top of the arbor or cutting tool turr toward the front of the saw.
3. Set the cutting tool as low as possible for the cut you're planning.
4. **KEEP CHILDREN AWAY.** All visitors should be kept a safe distance from work. Make sure bystanders are clear of the saw and workpiece.
5. Let the blade reach full speed before cutting.
6. **DON'T FORCE TOOL.** It will do the job better and safer at its designed rate. Feed the workpiece into the blade only fast enough to let it cut without bogging down or binding.
7. Before freeing any jammed material:
 - A. Turn switch "OFF".
 - B. Unplug the saw.
 - C. Wait for all moving parts to stop.
 - D. Check blade, Spreader and Fence for proper alignment before starting, again.
8. To avoid throwback of cut off pieces;
 - A. Use the Guard Assembly.
 - B. To remove loose pieces beneath or trapped inside the Guard:
 1. Turn saw "OFF".
 2. Remove Switch Key.
 3. Wait for blade to stop before lifting the Guard.

BEFORE LEAVING THE SAW

1. Turn the saw off.
2. Wait for blade to stop spinning.
3. Make workshop child-proof. Lock the shop. Disconnect master switches. Remove the yellow Switch Key. Store it away from children and others not qualified to use the tool.
4. Unplug the saw.

basic saw operation – using the miter gauge

The MITER GAUGE IS USED when CROSSCUTTING, MITER CUTTING, BEVEL CUTTING, COMPOUND MITER CUTTING, DADOING and when RABBETING AND MOLDING across the end of a narrow workpiece.

WARNING: For your own safety, always observe the following safety precautions in addition to the safety instructions on pages 2, 3, 4, 5, 36, & 37.

ADDITIONAL SAFETY INSTRUCTIONS FOR CROSS CUT TYPE CUTS.

Before starting:

1. Never use the Rip Fence when crosscutting.
2. An auxiliary wood facing attached to the Miter Gauge

CROSSCUTTING

Crosscut is known as a cutting or shaping operation made across the width of a workpiece.

The graduations on the Miter Gauge provide accuracy for average woodworking. In some cases where extreme accuracy is required, when making angle cuts, for example, make a trial cut and then re-check it with an accurate square, or protractor.

If necessary, the Miter Gauge head can be swiveled slightly to compensate for any inaccuracy.

NOTE: The space between the Miter Gauge Bar and the groove in the table is held to a minimum during manufacturing.

For maximum accuracy when using the Miter Gauge, always "favor" one side of the groove in the table. In other words, don't move the Miter Gauge from side to side while cutting, but keep one side of the bar riding against one side of the groove.

NOTE: Glue a piece of sandpaper to the face of the Miter Gauge head. This will help prevent the workpiece from "creeping" while it is being cut.

The Hold-Down Clamp (optional accessory) should be used on the Miter Gauge for greater accuracy.

The Miter Gauge may be used in either of the grooves in the table. Make sure it is locked.

WARNING: To avoid blade contact or kickback, hold Miter Gauge properly.

When cutting long workpieces, invert Auxiliary Fence/Work Support and position it on top of the Guide Bars to support the workpiece as near to the end as possible. If this does not adequately support the workpiece, you can make a simple support by clamping a piece of plywood to a sawhorse. See illustration above.

Use the Hold-Down Clamp (optional accessory) on the Miter Gauge for greater accuracy.

can help prevent workpiece twisting and throwbacks. Attach it to the holes provided. Make the facing long enough and big enough to support your work. Make sure, however, it will not interfere with the sawblade guard.

3. Use jigs or fixtures to help hold any piece too small to extend across the full length of the Miter Gauge face during the cut. This lets you properly hold the Miter Gauge and workpiece and helps keep your hands away from the blade.

While cutting:

1. To avoid blade contact, always hold the Miter Gauge as shown in this section.

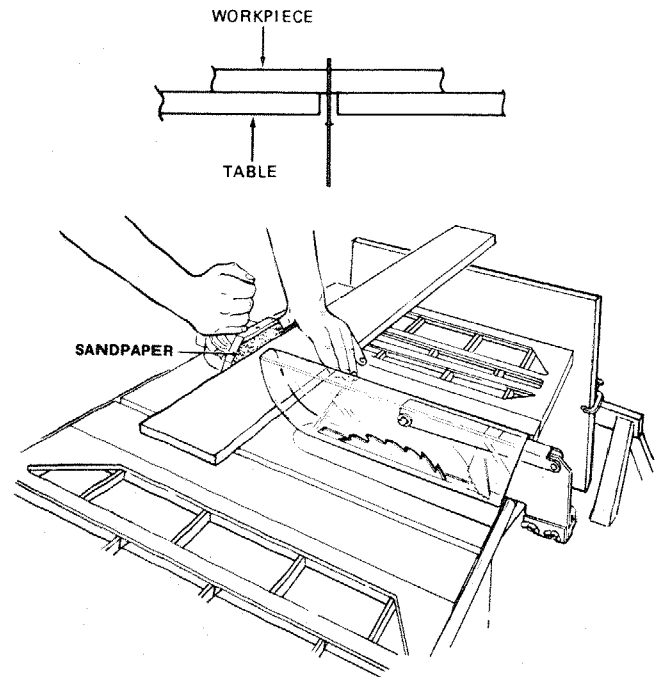

When using the Miter Gauge in the LEFT hand groove, hold the workpiece firmly against the Miter Gauge head with your left hand, and grip the lock handle with your right.

When using the RIGHT hand groove, hold the workpiece with your right hand and the Lock Handle with your left hand.

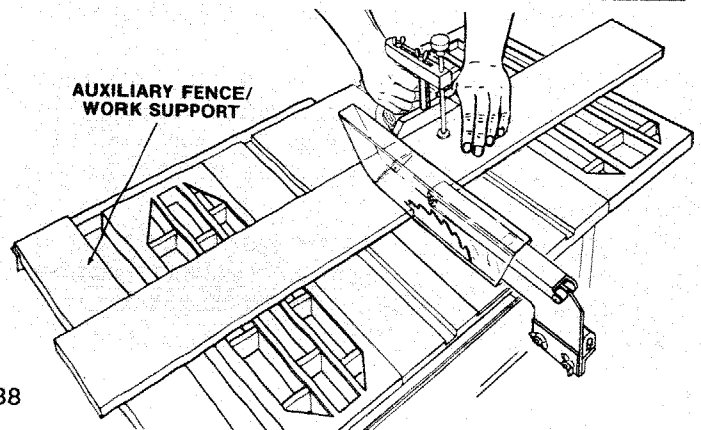

REPETITIVE CUTTING

REPETITIVE CUTTING is known as cutting a quantity of pieces the same length without having to mark each piece.

1. Use the Stop Rods (optional accessory) only for cutting duplicate pieces 6 inches long and longer.
2. When making repetitive cuts from a long workpiece, make sure it is adequately supported.

Use the Hold-Down Clamp (optional accessory) on the Miter Gauge for greater accuracy.

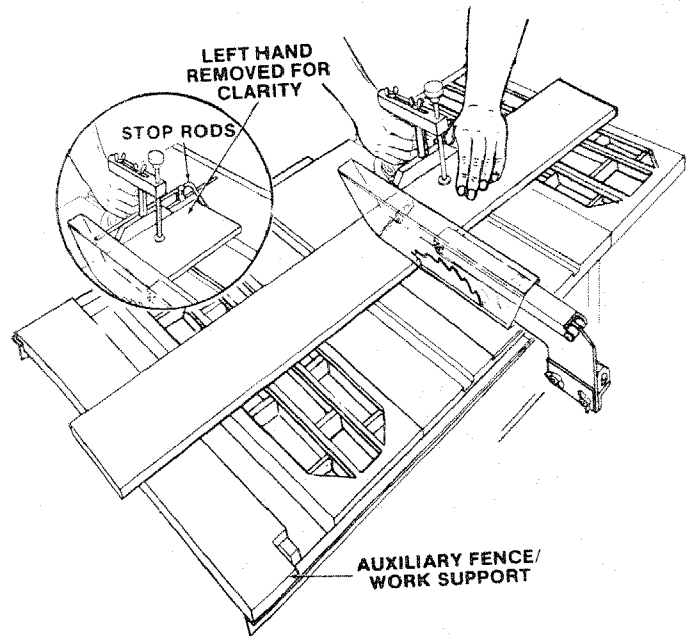

3. NEVER USE THE RIP FENCE AS A LENGTH STOP BECAUSE THE CUT-OFF PIECE COULD BIND BETWEEN THE FENCE AND THE BLADE CAUSING A KICKBACK.
4. When making repetitive cuts shorter than 6 inches, clamp a block of wood 2 inches long to the table to act as a length stop. Do not clamp directly to the bottom edge of the table because the "swivel" of the clamp will not grip properly. Place a small block of wood between the bottom edge of the table and the "C" clamp.

CAUTION: Avoid kickback from twisting the workpiece. When clamping the block, make sure that the end of the block is well in front of the sawblade. Be sure it is clamped securely.

5. Slide the workpiece along the Miter Gauge until it touches the block, hold it securely. Use Hold-Down Clamp (optional accessory) for greater accuracy.
6. Make the cut, pull the workpiece back, turn saw off, wait for blade to stop and remove cut off piece before continuing.

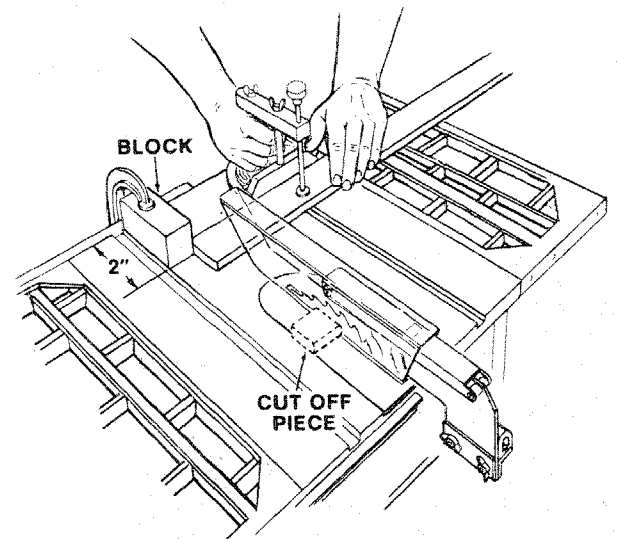

MITER CUTTING

MITER CUTTING is known as cutting wood at an angle other than 90° with the edge of the wood. Follow the same procedure as you would for crosscutting.

Adjust the Miter Gauge to the desired angle, and lock it. The Miter Gauge may be used in either of the grooves in the table.

When using the Miter Gauge in the LEFT hand groove, hold the workpiece firmly against the Miter Gauge head with your left hand, and grip the Lock Knob with your right.

When using the RIGHT hand groove, hold the workpiece with your right hand and the Knob with your left hand.

Use the Hold-Down Clamp (optional accessory) on the Miter Gauge for greater accuracy.

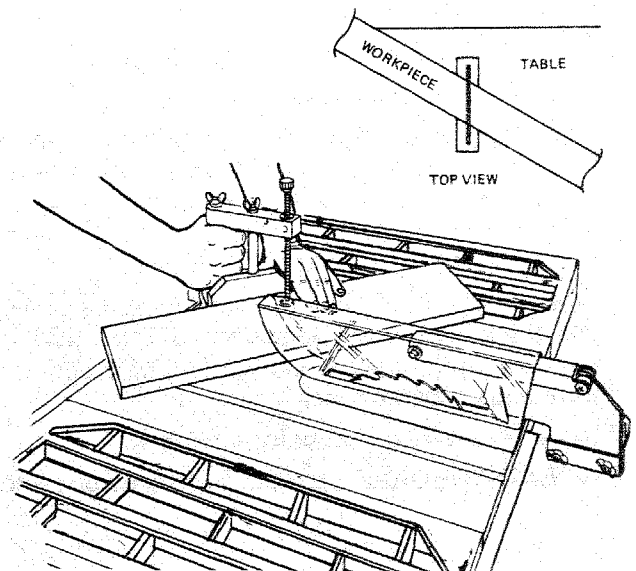

basic saw operations

BEVEL CROSSCUTTING

BEVEL CROSSCUTTING is the same as crosscutting except that the wood is also cut at an angle, other than 90° with the flat side of the wood.

Lower blade to about 2 inches above the table top before tilting blade. Failure to do this may result in damage to your saw.

Adjust the blade to the desired angle.

Use the Miter Gauge in the groove to the RIGHT of the blade. It cannot be used in the groove to the LEFT because the Blade Guard will interfere. Hold the workpiece with your right hand and the Lock Handle with your left hand.

Use the Auxiliary Fence/Work Support for additional support of the workpiece.

Lay it across the Guide Bars to support the workpiece as near to the end as possible.

Use the Hold-Down Clamp (optional accessory) on the Miter Gauge for greater accuracy.

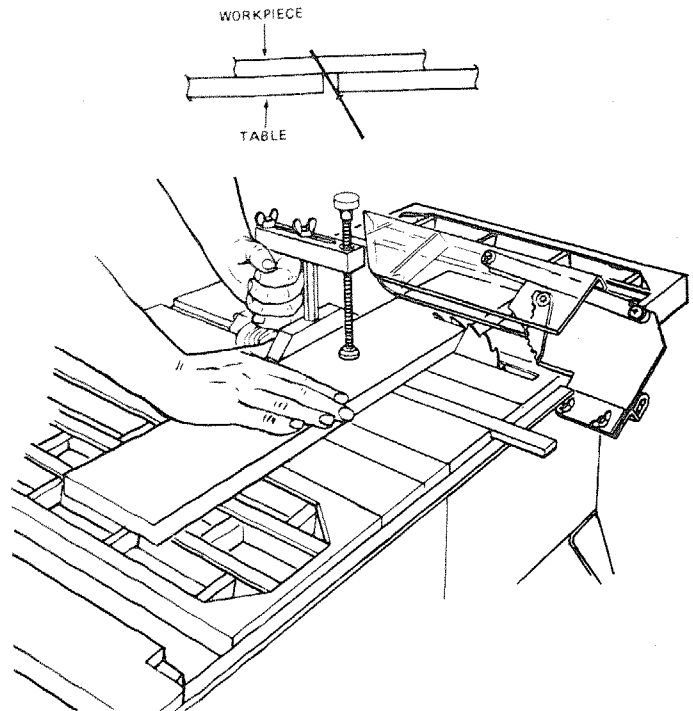

COMPOUND MITER CUTTING

COMPOUND MITER CUTTING is a combination of miter cutting and bevel crosscutting. The cut is made at an angle other than 90° to both the edge and the flat side of the wood.

Adjust the Miter Gauge and the blade to the desired angle. Make sure Miter Gauge is locked.

using the rip fence

RIPPING, BEVEL RIPPING, PLOUGHING, MOLDING, RESAWING AND RABBETING are performed using the RIP FENCE together with the AUXILIARY FENCE/WORK SUPPORT, PUSH STICK OR PUSH BLOCK.

WARNING: For your own safety, always observe the following safety precautions in addition to the safety instructions on pages 2, 3, 4, 5, 36, & 37.

ADDITIONAL SAFETY INSTRUCTIONS

1. NEVER use the Miter Gauge when ripping.
2. Use a Push Stick whenever the fence is 2 or more inches from the blade. When thru-sawing, use an auxiliary fence and push block whenever the fence must be between 1/2 and 2 inches of the blade. Never thru-saw rip cuts less than 1/2 inch wide.
3. When using a Push Stick or Push Block, the trailing end of the board must be square. A Push Stick or Block against an uneven end could slip off or push the work away from the fence.
4. Never rip anything shorter than 10" long.
5. A FEATHERBOARD can help guide the workpiece.

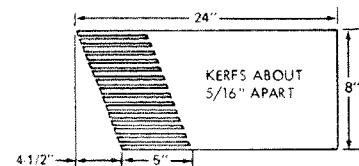

Before starting:

1. To avoid kickbacks and slips into the blade, make sure the Rip Fence is parallel to the sawblade.
2. Check the Anti-Kickback Pawls. (See BASIC SAW OPERATION - USING THE RIP FENCE.) The Pawls must stop a kickback once it has started. Replace or sharpen Anti-Kickback Pawls when points become dull.
3. Plastic and composition (like hardboard) materials may be cut on your saw. However, since these are usually quite hard and slippery, the Anti-Kickback Pawls may not stop a kickback. Therefore, be especially careful in your set-up and cutting procedures.

While cutting:

1. To avoid kickbacks and slips into the blade, always push forward on the section of the workpiece between the saw blade and the Rip Fence. Never push forward on the piece being cut off.

RIPPING

Ripping is known as a cutting operation along the length of the workpiece.

Position the Fence to the desired WIDTH OF RIP and lock in place.

Before starting to rip, be sure:

1. Rip Fence is parallel to sawblade.
2. Spreader is properly aligned with sawblade.
3. Anti-Kickback Pawls are functioning properly.

When ripping LONG BOARDS or LARGE PANELS, always use a work support.

A simple one can be made by clamping a piece of plywood to a sawhorse.

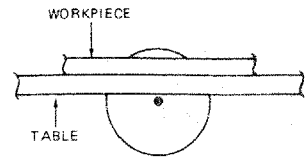

ALWAYS SUPPORT LONG OR WIDE WORKPIECES!

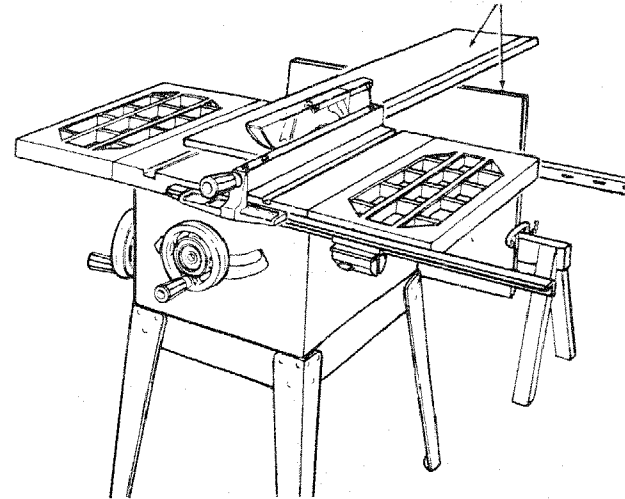

Keep your hands out of the blade path.

WARNING: To avoid kickback, use LEFT hand ONLY to guide the workpiece. Do not FEED the workpiece with your left hand.

Stop your left thumb at the front edge of the table. Finish the cut with the appropriate pusher.

Feed the workpiece by pushing forward only on the part of the workpiece that will pass between the blade and the fence.

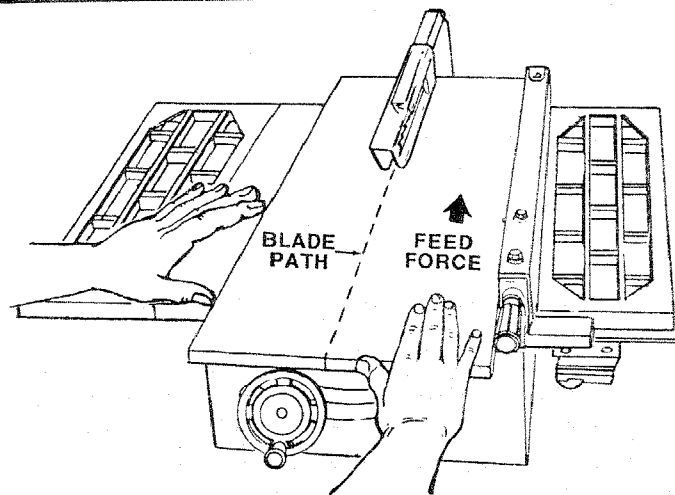

Once the trailing end is on the table:

When "WIDTH OF RIP" is 2 inches or wider, use the Push Stick to finish pushing the work all the way past the blade.

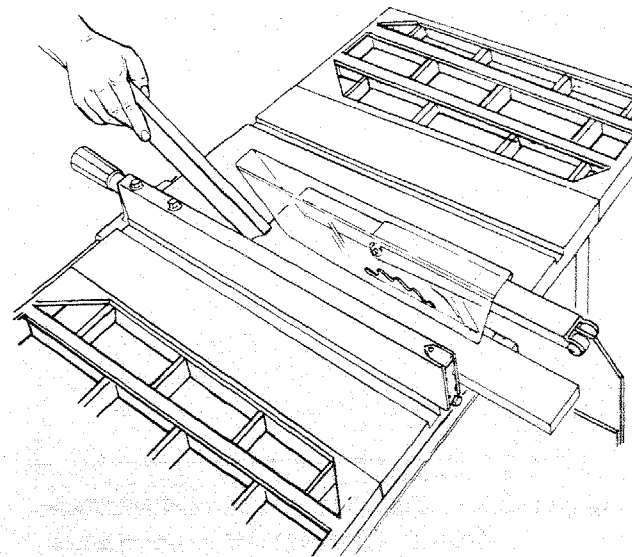

basic saw operations

When WIDTH OF RIP is 1/2 inch to 2 inches, the Push Stick CANNOT be used because the Guard will interfere. USE the Auxiliary Fence/Work Support and Push Block.

Attach Auxiliary Fence/Work Support to Rip Fence with two "C" clamps.

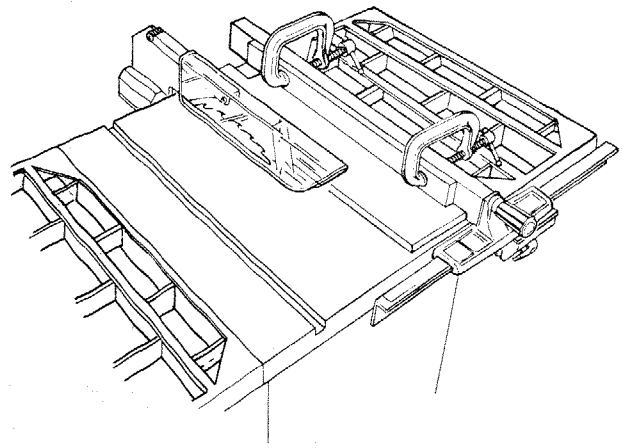

Feed the workpiece by hand along the Auxiliary Fence until the end is approximately 1 inch past the front edge of the table. Continue to feed using the Push Block.

Hold the workpiece in position and install the Push Block by sliding it on top of the Auxiliary Fence/Work Support (this may raise Guard).

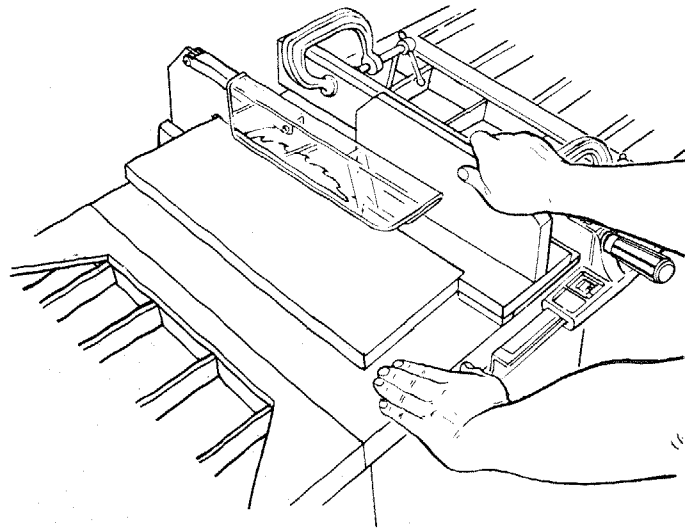

WARNING: To avoid injury from blade contact, never thru-saw cuts narrower than 1/2 inch wide.

Narrow strips thicker than the Auxiliary Fence/Work Support may enter the Guard and strike the Baffle. CAREFULLY raise Guard only enough to clear the workpiece. Use Push Block to complete cut.

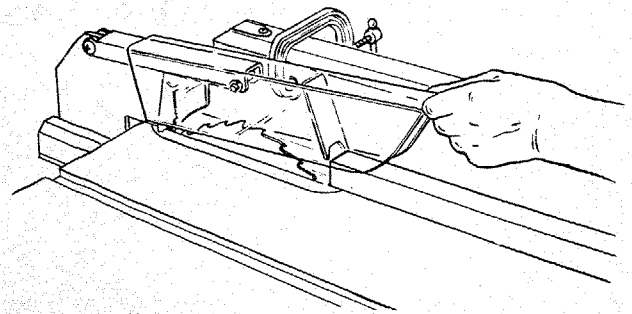
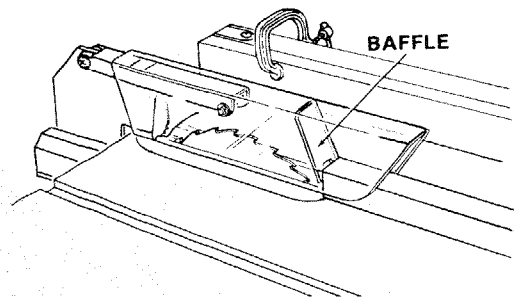

USING FEATHERBOARDS FOR THRU SAWING

Featherboards are NOT employed for thru-sawing operations when using the Miter Gauge.

Featherboards are used to keep the work in contact with the Fence and table as shown, and to help stop kickbacks.

Add 7-1/2 inch high flat facing board to the Fence, the full length of the Fence.

Mount Featherboards to Fence and table as shown, so that leading edges of Featherboards will support workpiece.

WARNING: Make sure the Featherboard against the edge presses only on the uncut position (in front of the blade). It might otherwise pinch the blade in the kerf and cause a kickback.

Before starting the operation (switch "OFF" and cutter below table surface):

1. Install Featherboards so they exert pressure on the workpiece; be positive they are secure, and
2. Make sure by trial that the Featherboards will stop a kickback if one should occur.

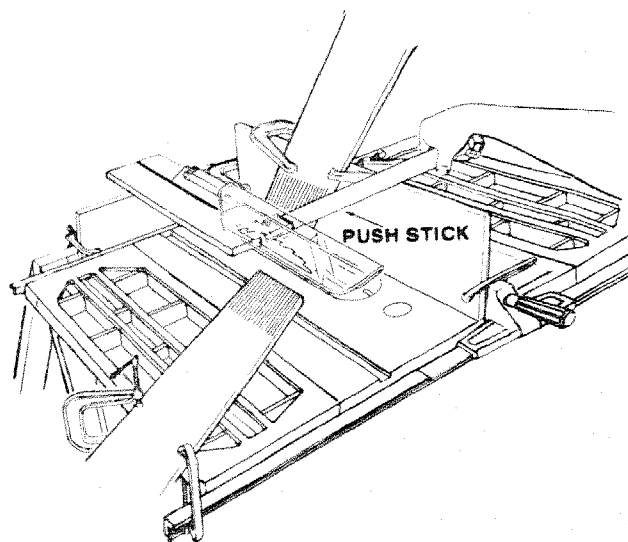
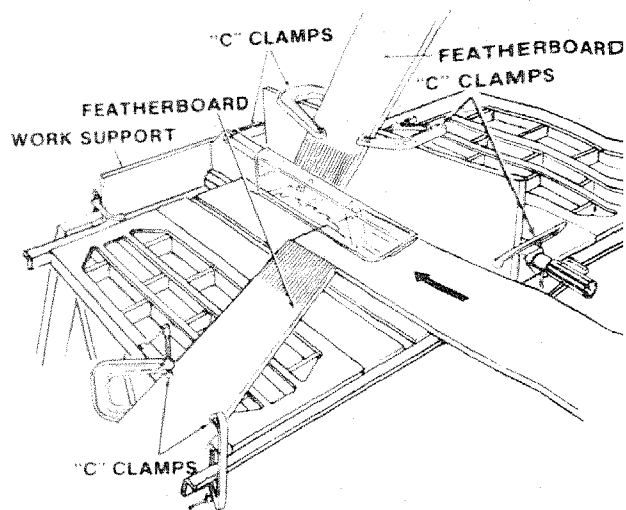

RESAWING

RESAWING is a thru-sawing cut made by ripping a piece of wood through its thickness. Do not attempt to resaw BOWED or WARPED material.

NOTE: To RESAW a piece of wood wider than 3-3/8 inches, it will be necessary to remove the blade guard and use the Auxiliary Fence/Work Support. (See "WORK HELPERS").

Clamp it to the table so that the workpiece will SLIDE EASILY but not TILT or MOVE SIDEWAYS without BINDING between the two Fences.

Do not clamp directly to the bottom edge of the table because the "swivel" of the clamp will not grip properly. Place a small block of wood between the bottom edge of the table and the "C" clamp.

WARNING: For your own safety

1. Do not "Back up" (reverse feeding) while resawing because this could cause a kickback.
2. Make first pass to a depth slightly more than one-half the width of the board; keep same face of board against Fence for second pass.

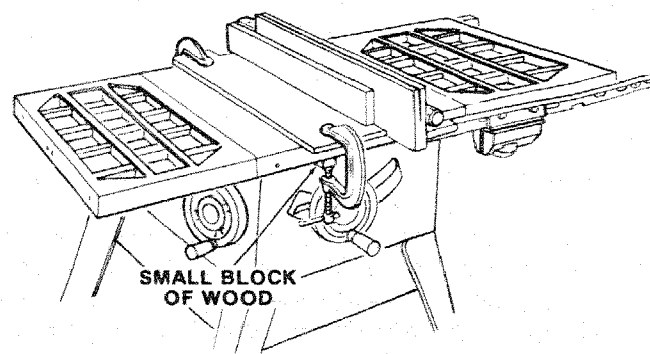

WARNING: Install Blade Guard immediately upon completion of the resawing operation.

basic saw operations

USING FEATHERBOARDS FOR NON-THRU SAWING

Featherboards are NOT employed during non thru-sawing operations when using the Miter Gauge.

USE FEATHERBOARDS FOR ALL OTHER NONTHRU-SAWING OPERATIONS (when Sawblade Guard must be removed). Featherboards are used to keep the work in contact with the Fence and table as shown, and to stop kickbacks.

Add 7-1/2 inch high flat facing board to the Fence, the full length of the Fence.

Mount Featherboards to Fence and table as shown, so that leading edges of Featherboards will support workpiece until cut is complete, and the workpiece has been pushed completely past the cutter (sawblade, Dado Head, Molding Head, etc.) with a Push Stick, as in ripping.

Before starting the operation (switch "OFF" and cutter below table surface):

1. Install Featherboards so they exert pressure on the workpiece; be positive they are secure, and
2. Make sure by trial that the Featherboards will stop a kickback if one should occur.

WARNING: For your own safety, replace the Sawblade Guard as soon as the non thru-sawing operation is complete.

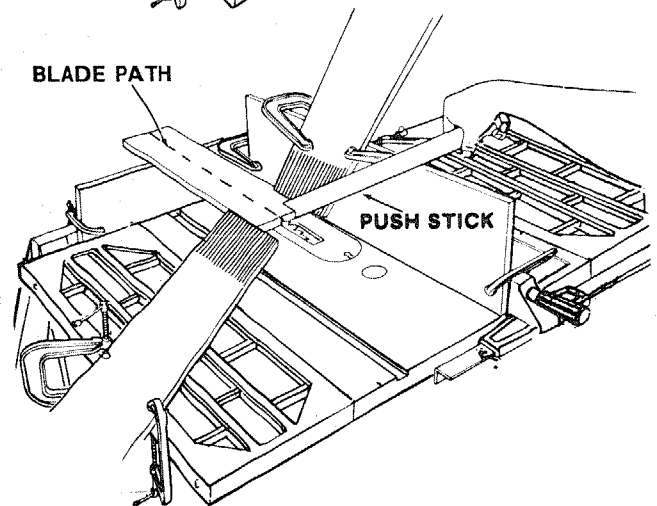
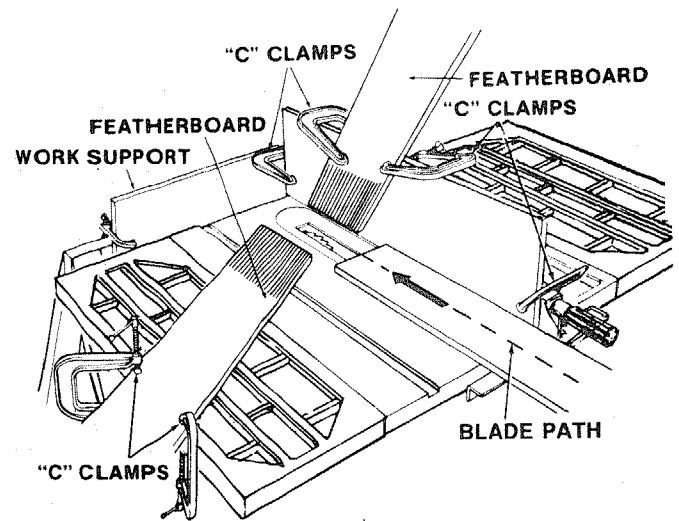

RABBETING

RABBETING is known as cutting out a section of the corner of a piece of material, across an end or along an edge.

To make a RABBET requires cuts which do not go all the way through the material. Therefore, the Blade Guard must be removed.

1. Remove Blade Guard.
2. For rabbeting along an edge (long way of workpiece) as shown, add facing to Rip Fence approximately as high as the workpiece is wide. Adjust Rip Fence and blade to required dimensions; then make first cut with board flat on table as any rip (type) cut; make second cut with workpiece on edge. Follow all precautions, safety instructions, and operational instructions as for ripping, or rip type operations, including Featherboards and Push Stick, etc.
3. For rabbeting across an end, for workpiece 10-1/2 inches and narrower, make the rabbet cut with the board flat on the table. Using the Miter Gauge fitted with a Facing, follow the same procedures and instructions for cross cutting making successive cuts across the width of the workpiece to obtain the desired width of cut. DO NOT use the Rip Fence for rabbeting across the end.

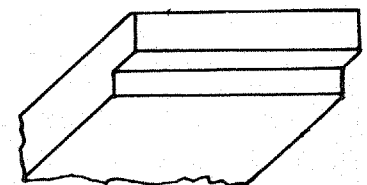
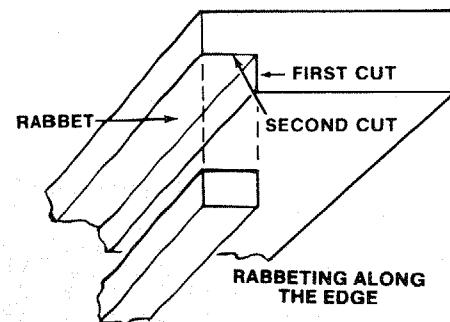

WARNING: For your own safety, install blade guard immediately upon completion of rabbeting operation.

Some rabbet cuts can also be made in one pass of the workpiece over the cutter using the Dado Head or Molding Head.

PLOUGHING AND MOLDING

PLOUGHING is grooving with the grain the long way of the workpiece, using the Fence. USE proper hold-downs and feed devices.

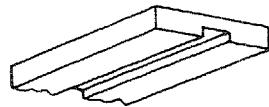

PLOUGHING

MOLDING is shaping the workpiece with the grain the long way of the workpiece, using the Fence. Use proper hold-downs and feed devices.

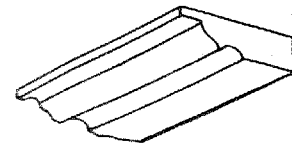

MOLDING

CUTTING PANELS

When cutting panels (whenever fence is positioned outside of table surface), ALWAYS use the Auxiliary Fence/Work Support.

1. Unlock Fence and raise rear end.
2. Position Auxiliary Fence/Work Support as shown and attach it with two "C" clamps.

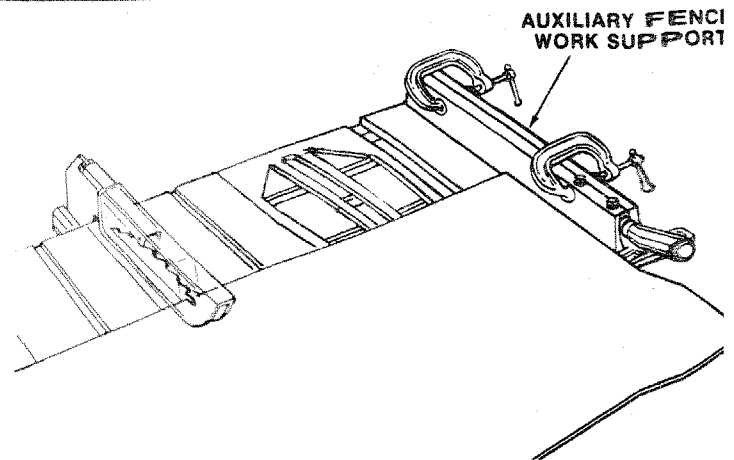

DADOING

Instructions for operating the Dado Head are contained in booklet furnished with the Dado Head.

The arbor on the saw, is only long enough so that the widest cut that can be made is 13/16 inch wide.

It is not necessary to install the outside loose collar before screwing on the arbor nut. Make sure the arbor nut is tight.

ALWAYS USE DADO INSERT LISTED UNDER "RECOMMENDED ACCESSORIES."

When using the Dado Head it will be necessary to remove the Blade Guard and Spreader. USE CAUTION. USE MITER GAUGE, FENCE, FEATHERBOARDS AND PUSH STICKS AS REQUIRED.

WARNING: For your own safety, always replace the blade, Guard and Spreader when you are finished Dadoing.

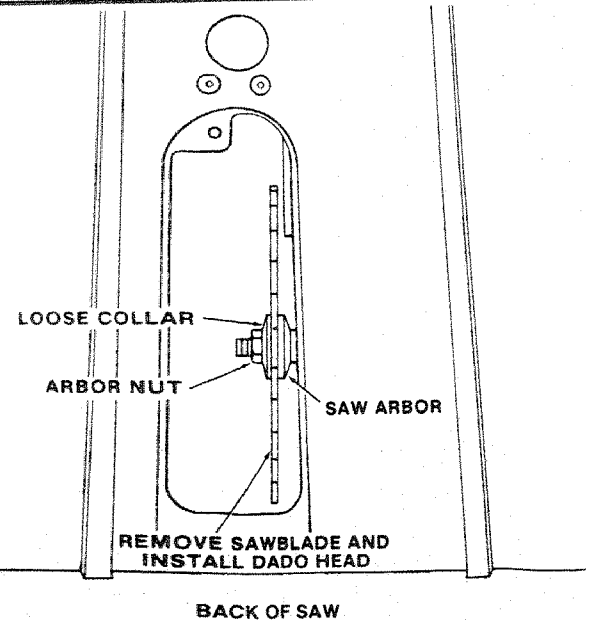

MOLDING CUTTING

Instructions for operating the Molding Head are contained in a booklet furnished with the Molding Head.

Always use Molding Insert listed under "RECOMMENDED ACCESSORIES".

When using the Molding Head, it will be necessary to remove the Blade Guard and Spreader. USE CAUTION.

USE MITER GAUGE, FENCE, FEATHERBOARDS AND PUSH STICKS, ETC. AS REQUIRED

WARNING: For your own safety, always replace the blade, Guard and Spreader when you are finished Molding.

motor

LUBRICATION AND MAINTENANCE

1. The bearings, in both end shields of the motor, have been lubricated at the factory with correct lubricant. No other part of the motor requires lubrication.
2. If disassembly of the motor is necessary, it should be returned to your nearest Sears retail or main-order store in order to prevent voiding the guarantee.

NOTE: The speed of this motor cannot be regulated or changed.

3. Every effort should be made to prevent foreign material from entering the motor. When operated under

conditions likely to permit accumulations of dust, dirt, or waste within the motor, a visual inspection should be made at frequent intervals. Accumulations of dry dust can usually be blown out successfully.

NOTE: Motors used on wood-working tools are particularly susceptible to the accumulation of sawdust and wood chips and should be blown out or "vacuumed" frequently to prevent interference with normal motor ventilation.

maintenance

WARNING: To avoid injury from accidental start, turn switch "OFF" and remove plug from power source outlet before maintaining or lubricating your saw.

Do not allow sawdust to accumulate inside the saw.

Frequently blow out any dust that may accumulate inside the saw cabinet and the motor.

Frequently clean your cutting tools with Craftsman Gum and Pitch Remover.

A coat of automobile-type wax applied to the table will help to keep the surface clean and allow workpieces to slide more freely.

If the power cord is worn or cut, or damaged in any way, have it replaced immediately.

Make sure the teeth of the Anti-Kickback Pawls are always sharp. To sharpen:

1. Remove Blade Guard.
2. Rotate Pawl toward rear of Spreader so that teeth are above top of Spreader.
3. Hold Spreader with left hand and place Pawl over corner of workbench.
4. Using a small round file (smooth cut) sharpen the teeth.

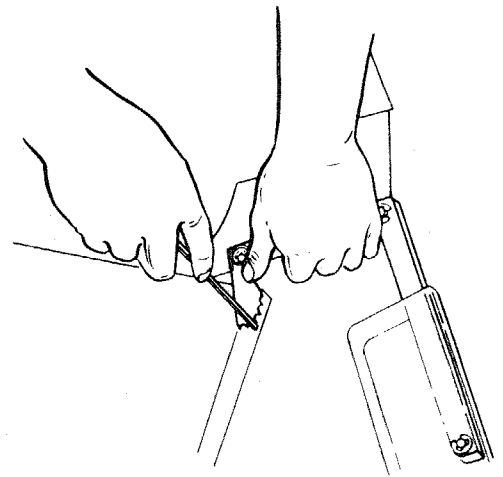

Lubrication

The saw motor bearings have been packed at the factory with proper lubricant and require no additional lubrication. The following parts should be oiled occasionally with SAE no. 20 or no. 30 engine oil.

1. Tilt screw threads and pivot nut. (First clean with Craftsman Gum and Pitch Remover.)

2. Elevation screw threads and pivot nut. (First clean with Craftsman Gum and Pitch Remover).
3. Cradle bearing points.
4. Bearing points in Guard Assembly, Miter Gauge and Rip Fence.

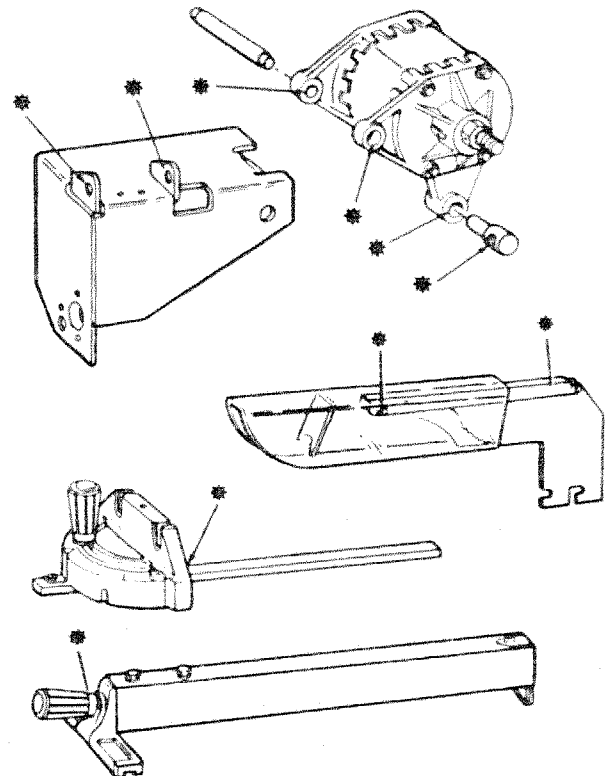
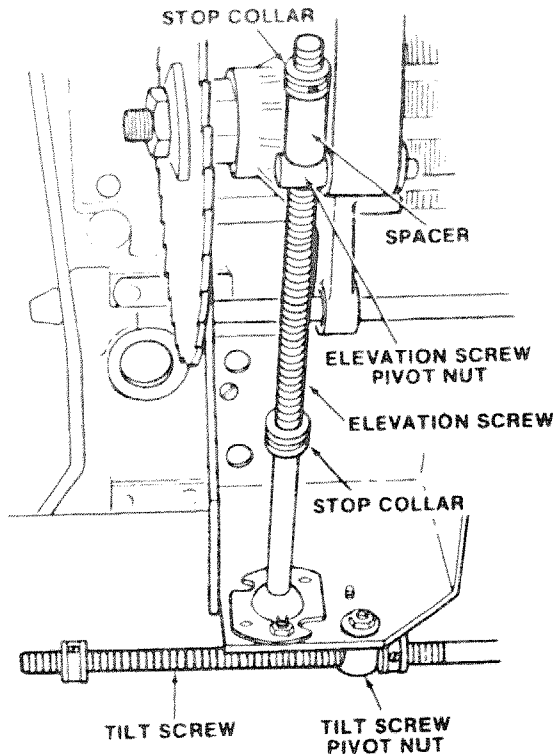

sears recommends the following accessories

ITEM	CAT. NO.	ITEM	CAT. NO.
Caster Sets.....	9-22222 or 9-22221	7 In. Dia. Dado Head.....	See Catalog
*7 In. Molding Head Set.....	See Catalog	Sanding Wheel.....	See Catalog
*7 In. Molding head.....	See Catalog	Miter Gauge Stop Rods.....	9-29924
Molding/Dado Insert for 7 In. Dia. Molding or Dado Head.....	9-29933	Miter Gauge Hold-Down Clamp.....	9-29928
Work Light.....	See Catalog	Taper Jig.....	See Catalog
Sawdust Collection System.....	9-29962	Universal Jig.....	See Catalog
7 In. Dia. Adjustable Dado Head.....	See Catalog	"Power Tool Know How Handbook".....	9-29117

* Smaller diameter Molding Heads cannot be used because they do not provide adequate depth of cut.

The above recommended accessories are current and were available at the time this manual was printed.



troubleshooting

WARNING: For your own safety, turn switch "OFF" and always remove plug from power source outlet before trouble shooting.

TROUBLE SHOOTING - GENERAL

TROUBLE	PROBABLE CAUSE	REMEDY
Excessive vibration.	1. Blade out of balance.	1. Discard Blade and use a different blade.
Cannot make square cut when crosscutting.	1. Miter gauge not adjusted properly.	1. See "Adjustments" section "Miter Gauge."
Cut binds, burns or stalls motor when ripping.	1. Dull blade or improper tooth set. 2. Blade is Heeling. 3. Warped board. 4. Rip fence not parallel to blade. 5. Spreader out of alignment.	1. Sharpen or replace blade. 2. See "Adjustments" section, "Heeling Adjustment .." 3. Make sure concave or hollow side is facing "down," feed slowly. 4. See "Assembly" section, "Aligning Rip Fence." 5. See "Assembly" section, "Installing Blade Guard."
Cut not true at 90° or 45° positions.	1. Stop screw not properly adjusted.	1. See "Adjustments" section, "Blade Tilt, or Squareness of Blade to Table."
Tilt and elevating handwheel turn hard.	1. Sawdust on threads of tilt screw or elevating screw. 2. Bearing retainers too tight.	1. See "Maintenance" and "Lubrication" section. 2. See "Maintenance" section, "Tilt and Elevation Mechanism"

TROUBLESHOOTING - MOTOR

NOTE: Motors used on wood working tools are particularly susceptible to the accumulation of sawdust and wood chips and should be blown out or "vacuumed" frequently to prevent interference with normal motor ventilation.

TROUBLE	PROBABLE CAUSE	REMEDY
Excessive noise.	1. Motor	1. Have motor checked by qualified service technician. Repair service is available at your nearest Sears store.
Motor fails to develop full power. NOTE: Low Voltage: (Power output of motor decreases rapidly with decrease in voltage at motor terminals. For example, a reduction of 10% in voltage causes a reduction of 19% in maximum power output of which the motor is capable, and a reduction of 20% in voltage causes a reduction of 36% in maximum power output.)	1. Circuit overloaded with lights, appliances and other motors. 2. Undersize wires or circuit too long. 3. General overloading of power company facilities. (In some sections of the country, demand for electrical power may exceed the capacity of existing generating and distribution systems.) 4. Incorrect fuses or circuit breakers in power line.	1. Do not use other appliances or motors on same circuit when using the saw. 2. Increase wire sizes, or reduce length of wiring. See "Motor Specifications and Electrical Requirements" section. 3. Request a voltage check from the power company. 4. Install correct fuses or circuit breakers.

TROUBLESHOOTING - MOTOR (CONT'D)

TROUBLE	PROBABLE CAUSE	REMEDY
Motor starts slowly or fails to come up to full speed.	<ol style="list-style-type: none"> 1. Low voltage will not trip relay. 2. Windings burned out or open. 3. Starting relay not operating. 	<ol style="list-style-type: none"> 1. Request voltage check from the power company. 2. Have motor repaired or replaced. 3. Have relay replaced.
Motor overheats.	<ol style="list-style-type: none"> 1. Motor overloaded 2. Improper cooling. (Air circulation restricted through motor due to sawdust, accumulating inside of saw.) 	<ol style="list-style-type: none"> 1. Feed work slower into blade. 2. Clean out sawdust to provide normal air circulation through motor. See "Maintenance" and "Lubrication" section.
Relay will not operate.	<ol style="list-style-type: none"> 1. Burned contacts (due to extended hold-in periods caused by low line voltage, etc.) 2. Saw not in upright position. 3. Loose or broken connectors 	<ol style="list-style-type: none"> 1. Have relay replaced and request a voltage check from the power company. 2. Place saw in upright position. 3. Have wiring checked and repaired.
Motor stalls (resulting in blown fuses or tripped circuit breakers.	<ol style="list-style-type: none"> 1. Started relay not operating. 2. Voltage too low to permit motor to reach operating speed. 3. Fuses or circuit breakers do not have sufficient capacity. 	<ol style="list-style-type: none"> 1. Have relay replaced. 2. Request voltage check from the power company. 3. Install proper size fuses or circuit breakers.
Frequent opening of fuses or circuit breakers.	<ol style="list-style-type: none"> 1. Motor overloaded 2. Fuses or circuit breakers do not have sufficient capacity. 3. Relay not operating (motor does not reach speed.) 	<ol style="list-style-type: none"> 1. Feed work slower into blade. 2. Install proper size fuses or circuit breakers. 3. Have relay replaced.

repair parts

PARTS LIST FOR CRAFTSMAN 10 INCH DIRECT DRIVE SAW MODEL NO. 113.226880 & 113.298090

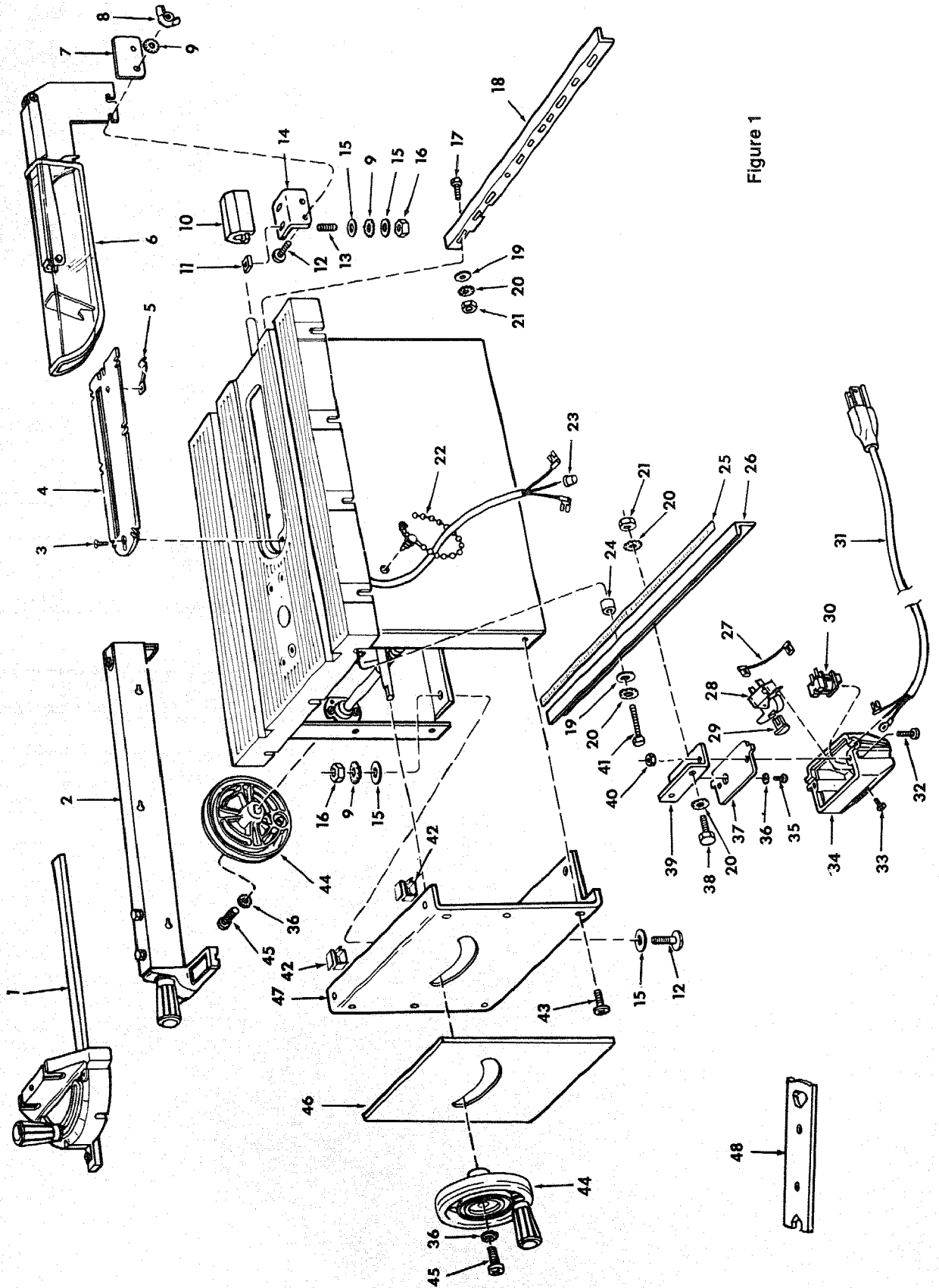

Figure 1



PARTS LIST FOR CRAFTSMAN 10 INCH DIRECT DRIVE SAW

MODEL NO. 113.226880 & 113.298090

Always Order by Part Number - Not by Key Number
FIGURE 1 PARTS LIST

Key No.	Part No.	Description
1	9-29929	+ Gauge Assembly, Miter (See Figure 8)
2	—	Fence Assembly, Rip (See Figure 4)
3	447441	Screw, Flat Hd. Type "T" 10-32 x 7/8
4	62514	Insert Assembly (Includes Key No. 5)
5	62545	Clip, Retaining
6	—	Guard Assembly (See Figure 3)
7	62643	Clamp, Spreader
8	STD541625	* Nut, Wing 1/4-20
9	STD551225	* Lockwasher, External Tooth 1/4
10	62642	Support, Spreader
11	62636	Nut, Square 1/4-20
12	60314	Screw, Truss 1/4-20 x 1/2
13	60074	Screw, Set Hex Cup 1/4-20 x 7/8
14	62809	Bracket
15	STD551025	* Washer, 17/64 x 9/16 x 1/16
16	STD541025	* Nut, Hex 1/4-20
17	STD523110	Screw, Hex Hd. 5/16-18 x 1
18	820425	Bar, Fence Rear
19	STD551031	* Washer, 21/64 x 5/8 x 1/16
20	STD551231	* Lockwasher, External Tooth 5/16
21	STD541231	* Nut, Hex 5/16-18
22	71165	Tie, Wire
23	STD375006	* Connector, Wire
24	62539	Spacer, Fence Guide Bar
25	62710	Tape, Fence

* Standard Hardware Item - May be purchased locally.

+ Stock Item - May be secured through the Hardware Department of most Sears Retail Stores.

Key No.	Part No.	Description
26	820617	Bar Assembly, Fence Guide (Includes Key No. 25)
27	818511	Lead Assembly
28	62442	Switch, Locking
29	9-22255	+ Key Switch
30	62975	Relay
31	805920	Cord with Plug
32	STD511105	* Screw, Pan Cross 10-32 x 5/8
33	STD600603	* Screw, Pan Cross Type "T" 10-32 x 3/8
34	62970	Housing, Switch
35	STD601103	* Screw, Pan Rec. Type "T" 10-32 x 3/8
36	STD551210	* Lockwasher, External No. 10
37	62924	Plate, Switch
38	STD523107	* Screw, Hex Hd. 5/16-18 x 3/4
39	62968	Bracket, Switch
40	STD541411	* Nut, Lock 10-32
41	STD523115	* Screw, Hex 5/16-18 x 1-1/2
42	62204	Clip, Cord
43	STD611105	* Screw, Pan Hd., Type "AB" No. 10 x 1/2
44	818526	Handwheel Assembly
45	STD511107	* Screw, Pan Hd. 10-32 x 5/8
46	820474	Panel, Trim
47	820435	Panel, Front
48	3540	Wrench, Arbor
—	SP5509	Owners Manual (Not illustrated)

▲ Model 113.226880 Only

■ Model 113.298090 Only

repair parts

PARTS LIST FOR CRAFTSMAN 10 INCH DIRECT DRIVE SAW MODEL NO. 113.226880 & 113.298090

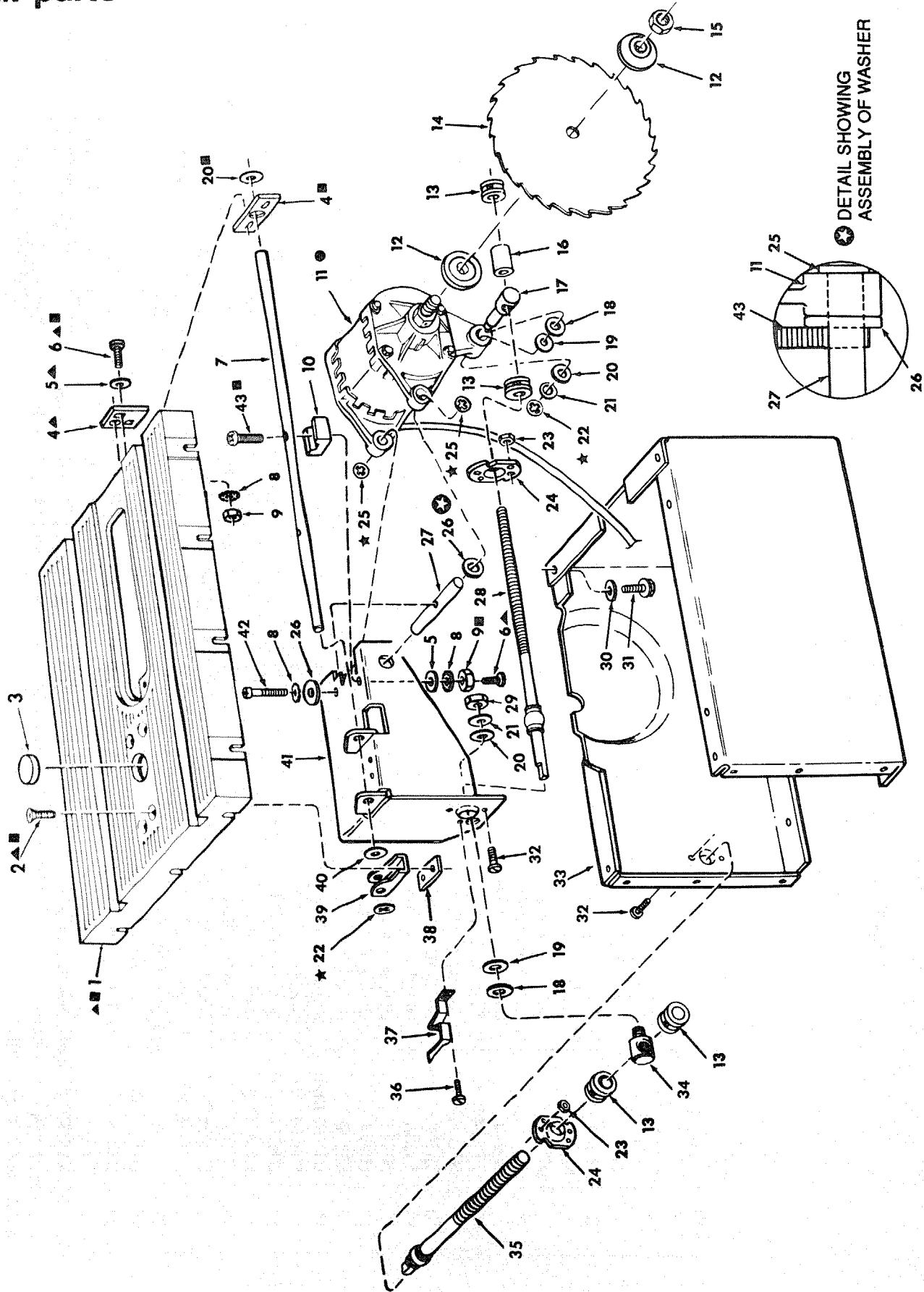

DETAIL SHOWING ASSEMBLY OF WASHER



**PARTS LIST FOR CRAFTSMAN 10 INCH DIRECT DRIVE TABLE SAW
MODEL NO. 113.226880 & 113.298090**

Always order by Part Number - not by Key Number
FIGURE 2 - PARTS LIST

Key No.	Part No.	Description
1	62977	▲ Table Saw
	62791	■ Table Saw
2	805297-8	▲ Screw, Flat Hd. 5/16-18 x 1-1/2
	805297-1	■ Screw, Flat Hd. 5/16-18 x 1-1/4
3	62493	Insert, Exact-I-Cut
4	62976	▲ Support, Rod
	62629	■ Support, Rod
5	STD551012	*▲ Washer, 7/32 x 7/16 x 1/16
6	STD511110	*▲ Screw, Pan Hd. 10-32 x 1
	STD511107	*■ Screw, Pan Hd. 10-32 x 3/4
7	62624	Rod, Cradle
8	STD551210	* Lockwasher, External Tooth No. 10
9	STD541110	* Nut, Hex No. 10-32
10	62792	Spacer, Cradle Rod
11	62962	• Motor
12	62498	Collar, Blade
13	62683	Collar, Stop L.H.
14	9-32668	† Blade, Saw 10Inch
15	6362	Nut, Arbor
16	60303	Spacer
17	62681	Nut, Elevation Pivot
18	60328	Washer, Nylon
19	806200-2	Washer, Rubber
20	62648	Washer, Rubber

Key No.	Part No.	Description
21	STD551037	* Washer, 17/64 x 47/64 x 1/16
22	60301	★ Ring, Retaining 3/8
23	STD541411	* Nut, Lock 10-32
24	62437	Retainer Bearing
25	60436	★ Ring, Retaining 7/16
26	STD551050	* Washer, .505 x 1-1/8 x 1/16
27	62796	Rod, Motor (Includes Key #25)
28	62682	Screw Assembly, Elevation
29	STD541425	* Nut, Lock 1/4-20
30	STD551231	* Lockwasher, 5/16
31	60078	Screw, Hex Hd. Hd. 5/16-18 x 1/2
32	STD511103	* Screw, Pan Hd. 10-32 x 3/8
33	62967	Base, Saw
34	62685	Nut, Bevel Pivot
35	62684	Screw Assembly, Tilt
36	STD600803	* Screw, Type 'T' Pan 8-32 x 3/8
37	62686	Indicator, Bevel
38	62436	Nut, Twin
39	62625	Hanger
40	62435	Washer, Thrust 3/8 x 5/8 x 1/16
41	62623	Cradle Assembly
42	436594	Screw, Pan Hd. 10-32 x 1-1/2
43	436593	■ Screw, Pan Hd., 10-32 x 1-3/8

* Standard Hardware Item - May be purchased locally.
 + Stock Item - May be secured through the Hardware Department of most Sears Retail Stores.
 ★ If this part is removed, discard and replace with a new retaining ring.

• Any attempt to repair this motor may create a HAZARD unless repair is done by a qualified service technician. Repair service is available at your nearest Service Center/Department.

▲ Model 113.226880 Only

■ Model 113.298090 Only

repair parts

PARTS LIST FOR CRAFTSMAN 10 INCH TABLE SAW MODEL NO. 113.226880 & 113.298090

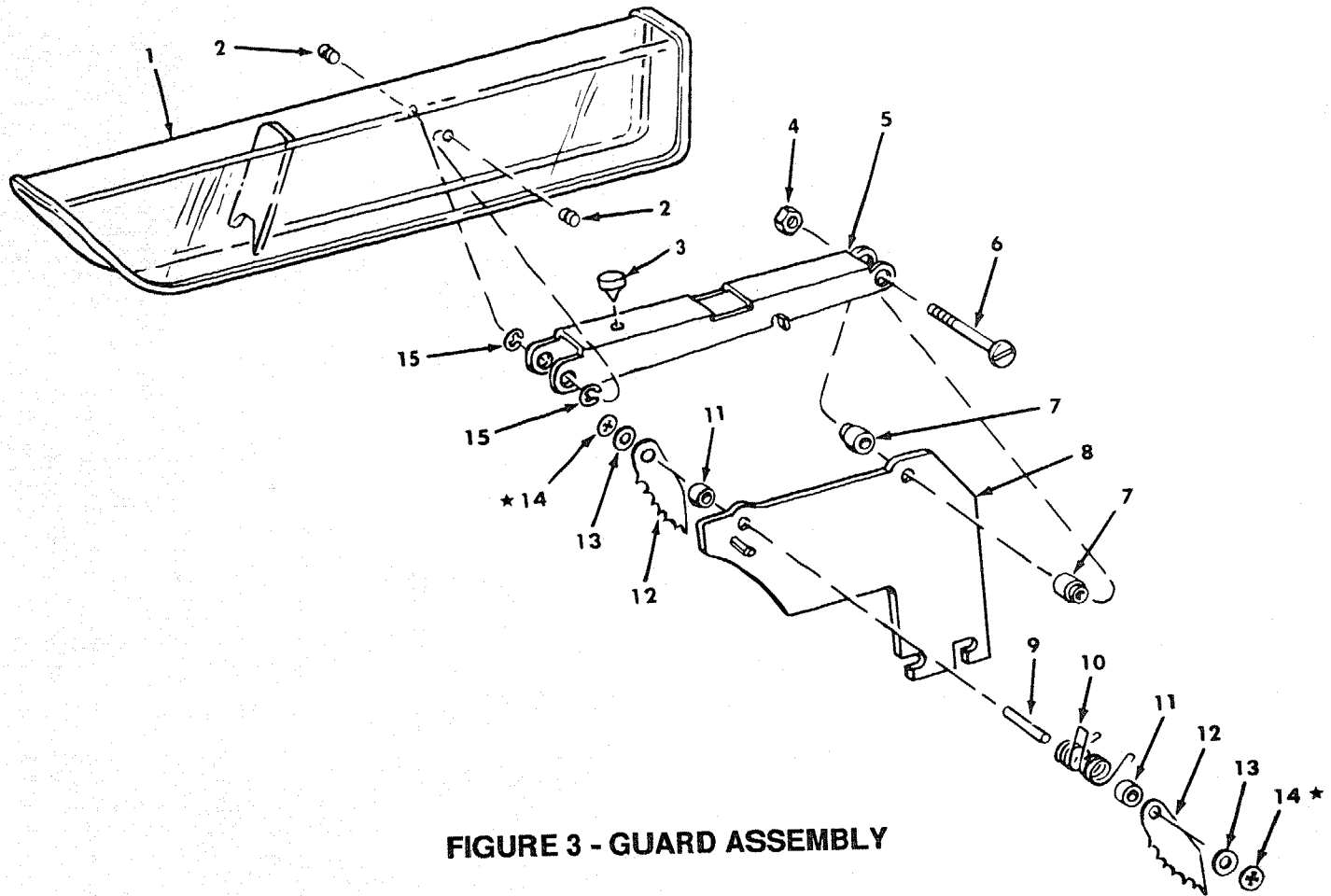

FIGURE 3 - GUARD ASSEMBLY

KEY NO.	PART NO.	DESCRIPTION
1	62415	Guard, Saw
2	62516	Pin
3	62650	Bumper, Snap In
4	STD541425	* Nut, Lock 1/4-20
5	62517	Link, Guard
6	STD512515	* Screw, Pan Hd., 1/4-20 x 1-1/2
7	62522	Spacer, Link
8	62810	Blade, Spreader
9	62410	Pin, 1/4 x 1-3/64
10	62519	Spring, Pawl
11	62520	Spacer, Pawl
12	62974	Pawl
13	STD551025	* Washer, 17/64 x 1/2 x 1/32
14	60208	* Nut, Push
15	STD581025	* Ring, Retaining 1/4

- * Standard Hardware Item - May be purchased locally
- ★ If this part is removed, discard and replace with a new push nut.

**PARTS LIST FOR CRAFTSMAN 10 INCH TABLE SAW
MODEL NO. 113.226880 & 113.298090**

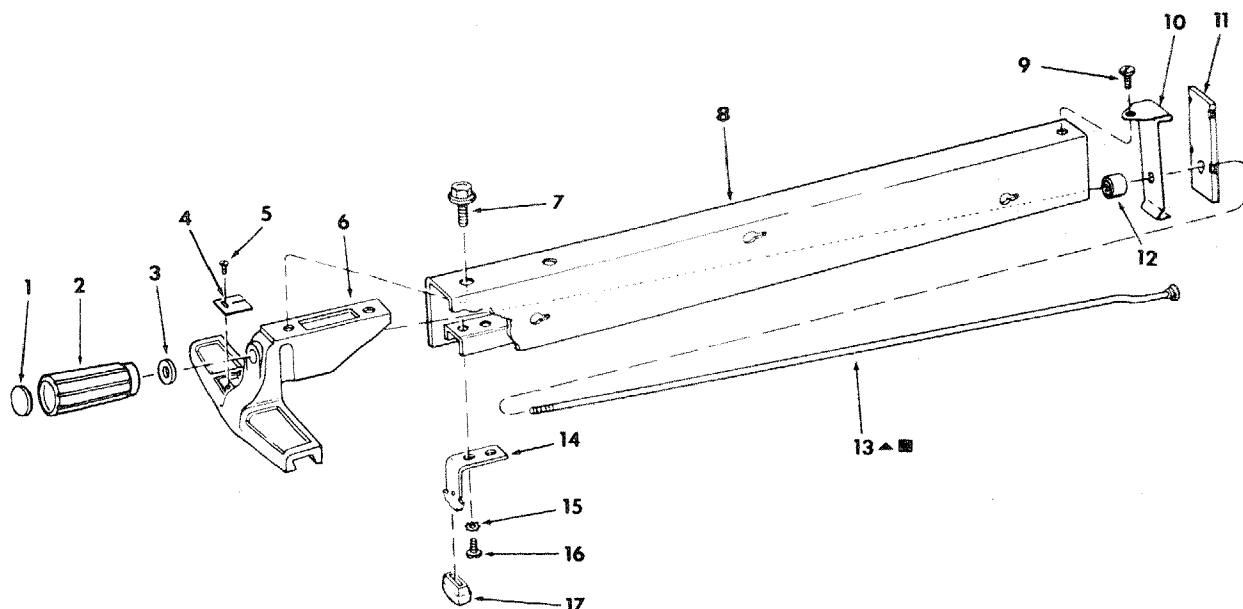

FIGURE 4 - FENCE ASSEMBLY

KEY NO.	PART NO.	DESCRIPTION
1	62693	Plug, Button
2	62692	Knob (Includes Key No. 1)
3	STD551031	* Washer, 21/64 x 1/2 x 1/32
4	62775	Indicator, Fence
5	9404336	* Screw, Pan Hd. Type "T" 4-40 x 1/4
6	62941	Head, Fence (Includes Key No. 4)
7	423567	Screw, Sems 3/8-16 x 1/2
8	62526	▲ Channel, Fence
	62582	■ Channel, Fence
9	STD600805	* Screw, Pan Hd. Type "T" 8-32 x 1/2
10	62528	Spring, Fence Lock
11	62529	Lock, Rear Fence
12	62531	Roller, Rear Fence
13	62530	▲ Rod, Fence Lock
	62944	■ Rod, Fence Lock
14	508112	Spring, Head Alignment (Includes Key No. 17)
15	STD551210	* Lockwasher, External No. 10
16	STD611005	* Screw, Type "A", Hex Hd. No. 10 x 1/2
17	62532	Pad, Alignment

* Standard Hardware Item - May be purchased locally.

▲ Model 113.226880

■ Model 113.298090



repair parts

PARTS LIST FOR CRAFTSMAN 10 INCH TABLE SAW MODEL NO. 113.226880

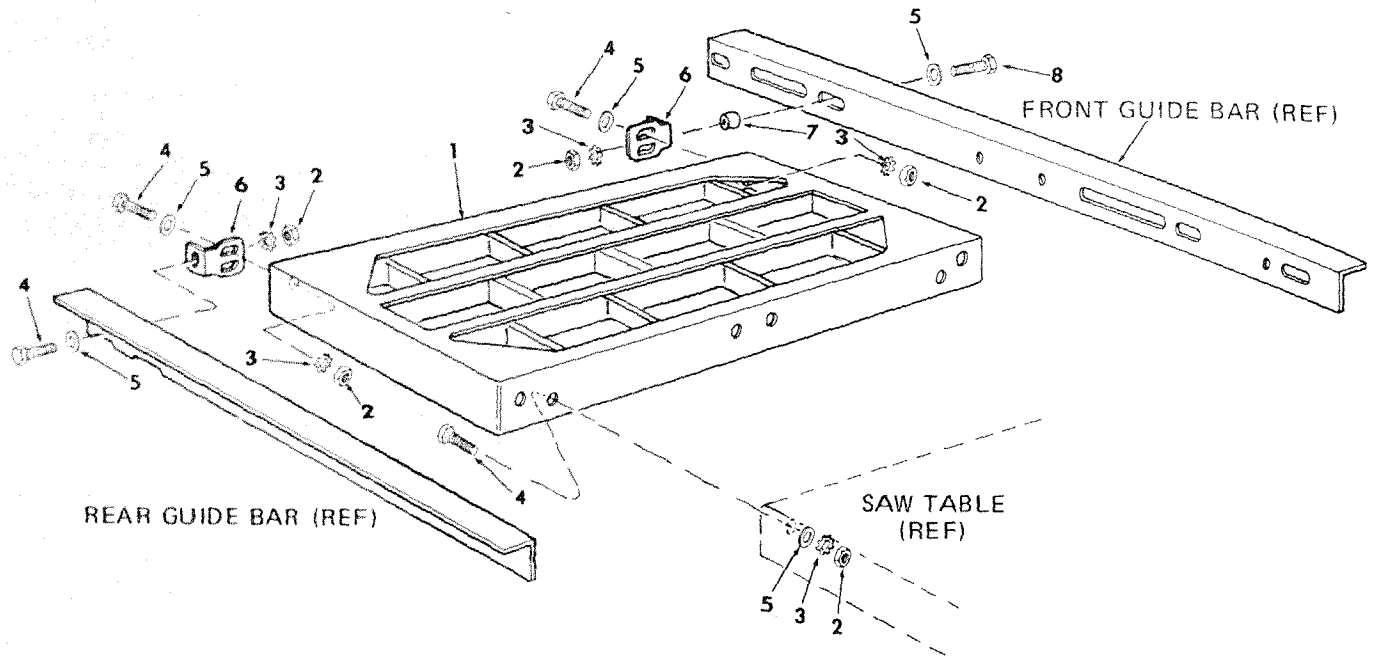

FIGURE 5 - TABLE EXTENSIONS

KEY NO.	PART NO.	DESCRIPTION
1	817745	Extension, Table 10 x 20
2	STD541231	* Nut, Hex 5/16-18
3	STD551231	* Lockwasher, External 5/16
4	STD523110	* Screw, Hex Head 5/16-18 x 1
5	STD551031	* Washer, 11/32 x 11/16 x 1/16
6	818308	Bracket
7	62539	Spacer, Fence Guide Bar
8	STD523115	* Screw, Hex Hd. 5/16-18 x 1-1/2

* Standard Hardware Item - May be purchased locally

**PARTS LIST FOR CRAFTSMAN 10 INCH TABLE SAW
MODEL NO. 113.298090**

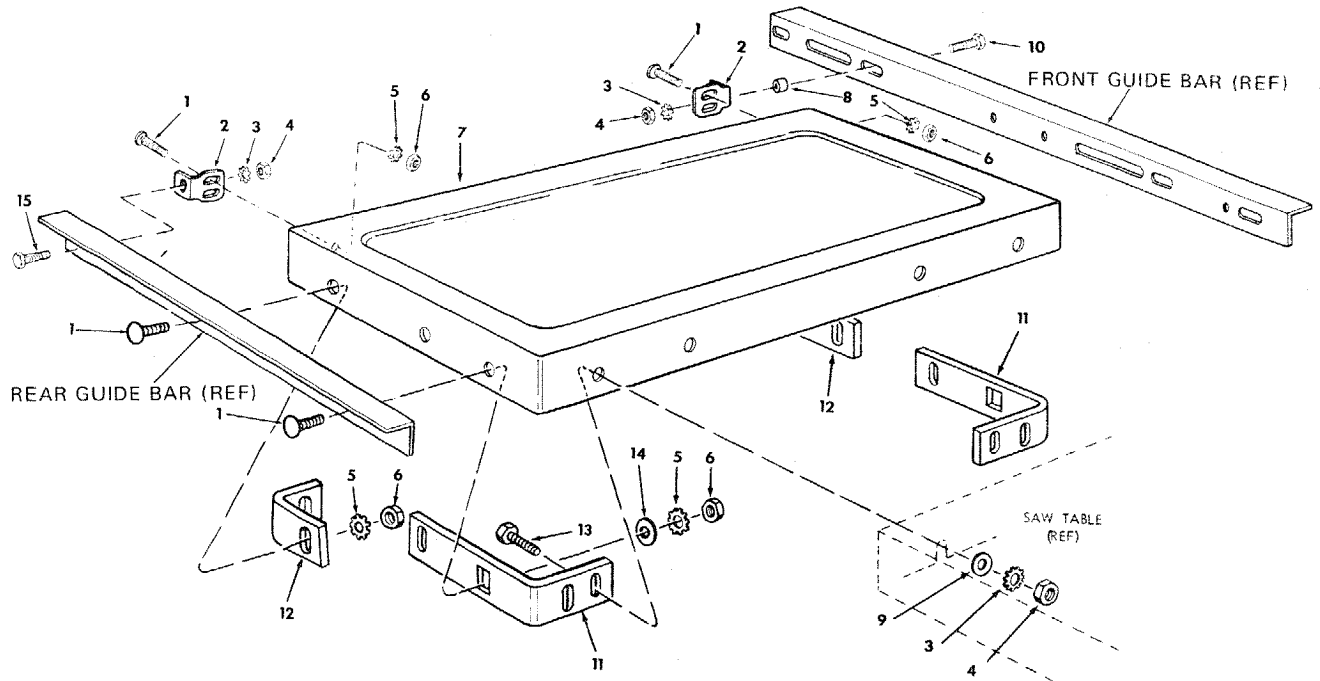

FIGURE 6 - TABLE EXTENSIONS

KEY NO.	PART NO.	DESCRIPTION
-	9-29957	† Extension Assembly, Complete
1	60323	Screw, Serrated Truss Hd., 1/4-20 x 1
2	818308	Bracket
3	STD551231	* Lockwasher, External 5/16
4	STD541031	* Nut, Hex 5/16-18
5	STD551225	* Lockwasher, External 1/4
6	STD541025	* Nut, Hex 1/4-20
7	62590	Extension, 10 x 27
8	62539	Spacer, Fence Guide Bar
9	STD551031	* Washer, 21/64 x 11/16 x 1/16
10	STD523115	* Screw, Hex Hd. 5/16-18 x 1-1/2
11	62549	Bracket, Corner Support No.2
12	62550	Bracket, Corner Stiffener
13	STD523112	* Screw, Hex Hd. 5/16-18 x 1-1/4
14	STD551025	* Washer, 17/64 x 3/4 x 1/16
15	STD523110	* Screw, Hex Hd. 5/16-18 x 1

* Standard Hardware Item - May be purchased locally

† Stock Item - May be secured through the Hardware Department of most Sears Retail Stores.



repair parts

PARTS LIST FOR CRAFTSMAN 10 INCH TABLE SAW MODEL NO. 113.226880 & 113.298090

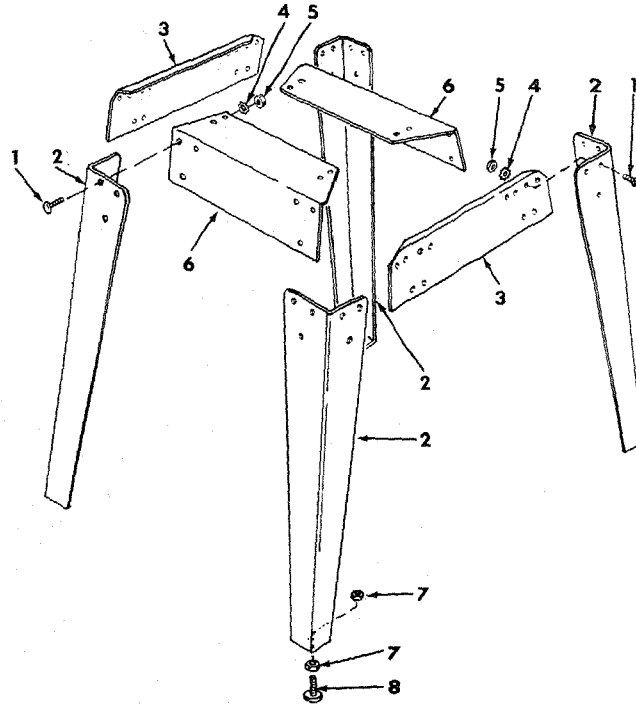

FIGURE 7 - LEG SET

KEY NO.	PART NO.	DESCRIPTION
1	60314	Screw, Serrated Truss Hd. 1/4-20 x 1/2
2	819441	Leg
3	62554	Stiffener, Side
4	STD551225	* Lockwasher, Ext. 1/4
5	STD541025	* Nut, Hex 1/4-20
6	62553	Stiffener, End
7	STD541237	* Nut, Hex 3/8-16
8	803835-1	Foot, Leveling, 3/8

* Standard Hardware Item - May be purchased locally.

**PARTS LIST FOR CRAFTSMAN 10 INCH TABLE SAW
MODEL NO. 113.226880 & 113.298090**

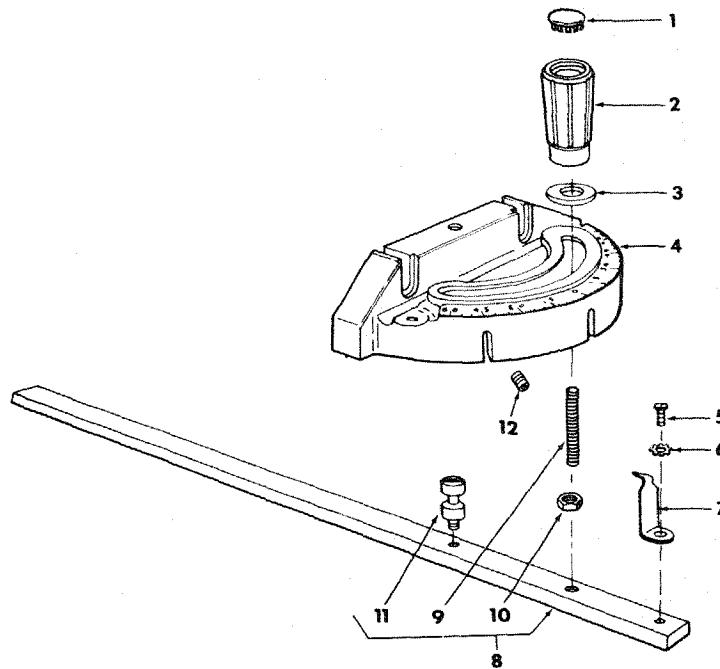

FIGURE 8 - MITER GAUGE ASSEMBLY

KEY NO.	PART NO.	DESCRIPTION
-	9-29929	+ Gauge Assembly, Miter
1	62693	Plug, Button
2	62692	Knob (Includes Key No. 1)
3	STD551031	* Washer, Plain, 21/64 x 1 x 1/16
4	37893	Gauge, Miter
5	STD510803	* Screw Pan Hd. 8-32 x 5/16
6	STD551208	* Lockwasher, External No. 8
7	62042	Indicator
8	62252	Rod Assembly, Miter Gauge, (Includes Key No. 9,10,11)
9	62225	Stud, Clamp
10	STD541231	* Nut, Hex. Jam, 5/16-18
11	62383	Stud, Pivot
12	60288	Screw, Locking Set, 1/4-20 x 3/8

* Standard Hardware Item - May be purchased locally.

+ Stock Item - May be secured through the Hardware Department of most Sears Retail Stores.



SEARS

owner's
manual

Model No.
113.226880
113.298090

Saw with Legs and Two
Table Extensions

The Model Number Of Your
Table Saw Is Found At The Rear
Of The Base.

When requesting service or
ordering parts, always provide
the following information:

- Product Type
- Model Number
- Part Number
- Part Description

10 INCH DIRECT DRIVE TABLE SAW

For the repair or replacement parts you need
Call 7 am - 7 pm, 7 days a week
1-800-366-PART
(1-800-366-7278)

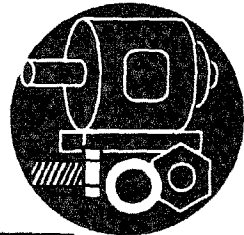

For in-home major brand repair service
Call 24 hours a day, 7 days a week
1-800-4-REPAIR
(1-800-473-7247)



For the location of a
Sears Repair Service Center in your area
Call 24 hours a day, 7 days a week
1-800-488-1222



For information on purchasing a Sears
Maintenance Agreement or to inquire
about an existing Agreement
Call 9 am - 5 pm, Monday-Saturday
1-800-827-6655



SEARS
REPAIR SERVICES
America's Repair Specialists

Sears, Roebuck and Co., Hoffman Estates, IL. 60179 U.S.A.