

# CDX EV Controller

## User Manual

Version: 1.1  
Publish date: 24/03/2026

### *Copyright*

Information in this document is subject to change without notice. Trademarks, trade names, service marks or service names owned or registered by any other company and used in this document are property of the respective companies.

### *Disclaimer*

Information contained in this document is confidential, privileged and only for the information of the intended recipient and may not be used, published, or redistributed without the prior written consent of CDX Technology Europe B.V.

### *Safety*

This product is designed to assist in improving safety on a go-karting track. While it may help reduce certain risks when used correctly, it does not eliminate hazards associated with go-karting activities and **cannot replace proper track safe operating procedures, trained personnel, or compliance with applicable safety regulations.**

While every effort has been made to ensure the accuracy of the information contained in this manual, the manufacturer cannot be held responsible for errors, omissions, or inaccuracies in this publication.

Copyright © 2026 CDX Technology Europe B.V.

FCC ID: 2BUQO-CDX-EVRC2301

### *Contact details*

Address:

Meander 551  
6825 MD Arnhem  
The Netherlands

General inquiries:

<https://www.cdx-technology.com>

Main office:

+31 85 2006 480

Technical support:

+31 6 1417 0924

Technical support email:

[support@cdx-technology.com](mailto:support@cdx-technology.com)

### *FCC statement*

Product name: CDX EV Controller

Responsible party: CDX Technology Europe B.V.

Address: Meander 551, 6825 MD Arnhem, the Netherlands

Website: <https://www.cdx-technology.com>

Tel: +31 85 2006 480

E-mail: [support@cdx-technology.com](mailto:support@cdx-technology.com)

This device complies with part 15 of the FCC Rules. Operation is subject to the following two conditions:

1. This device may not cause harmful interference, and
2. This device must accept any interference received, including interference that may cause undesired operation. Any Changes or modifications not expressly approved by the party responsible for compliance could void the user's authority to operate the equipment.

Note: This equipment has been tested and found to comply with the limits for a Class A digital device, pursuant to part 15 of the FCC Rules. These limits are designed to provide reasonable protection against harmful interference when the equipment is operated in a commercial environment. This equipment generates, uses, and can radiate radio frequency energy and, if not installed and used in accordance with the instruction manual, may cause harmful interference to radio communications. Operation of this equipment in a residential area is likely to cause harmful interference in which case the user will be required to correct the interference at his own expense.

## DOCUMENT REVISIONS

Version	Details	Date	Author
0.1	Initial user manual CDX EV Controller.	10-12-2025	WH
0.2	Added pinout.	15-12-25	WH
0.3	Update of document.	16-12-2025	TF/WH
0.4	Changed layout and added text.	17-12-2025	JFL/KKS
0.5	Update of document.	12-01-2026	CM/HV
0.6	Small changes, and correcting the technical data.	13-01-2026	WH
1.0	First version release.	15-01-2026	JFL/KKS
1.1	Processed feedback Applus.	24-03-2026	KKS

## TABLE OF CONTENTS

1	INTRODUCTION .....	5
1.1	Package contents .....	5
1.2	Compatible expansion components .....	5
1.3	Overview of product features.....	6
2	INSTALLATION GUIDE.....	7
2.1	Mounting instructions .....	8
2.2	Connector overview .....	8
2.3	Digital outputs.....	9
3	OPERATING INSTRUCTIONS.....	10
3.1	Speed restriction .....	10
3.2	7-segment display .....	10
3.3	Segment Slowdown.....	10
4	SYSTEM CONFIGURATION .....	11
4.1	Configuration terminal .....	11
4.2	Switch table.....	11
5	TECHNICAL DATA.....	12
5.1	Mounting points.....	13

# 1 Introduction

The CDX EV Controller is an electronic device, functioning exclusively as a radio receptor, designed to limit the maximum speed of an electric go-kart. See Chapter 5 (Technical data) for frequency and antenna details. The device can be controlled via a dedicated remote control or through external third-party software integration. The CDX EV Controller is designed to support operational safety on and around the go-karting tracks. This product is intended as a supplementary safety enhancement device and does not replace driver supervision and track control procedures.

## 1.1 Package contents

The CDX EV Controller is the only item that is supplied in the box which is shown in Figure 1.



Figure 1: CDX EV Controller

## 1.2 Compatible expansion components

- CDX Timing Sensor
  - o The CDX EV Controller can be combined with the CDX Timing Sensor for additional timing and segment speed limiting.
- CDX Phone Transceiver
  - o To request speed presets on the CDX EV Controller from a handheld device.
- CDX Tablet Transceiver
  - o To request speed presets on the CDX EV Controller from a fixed device.
- CDX Mini Remote
  - o To request speed presets on the CDX EV Controller from a handheld device.



### 1.3 Overview of product features

Figure 2 shows an overview of the product and its main features.

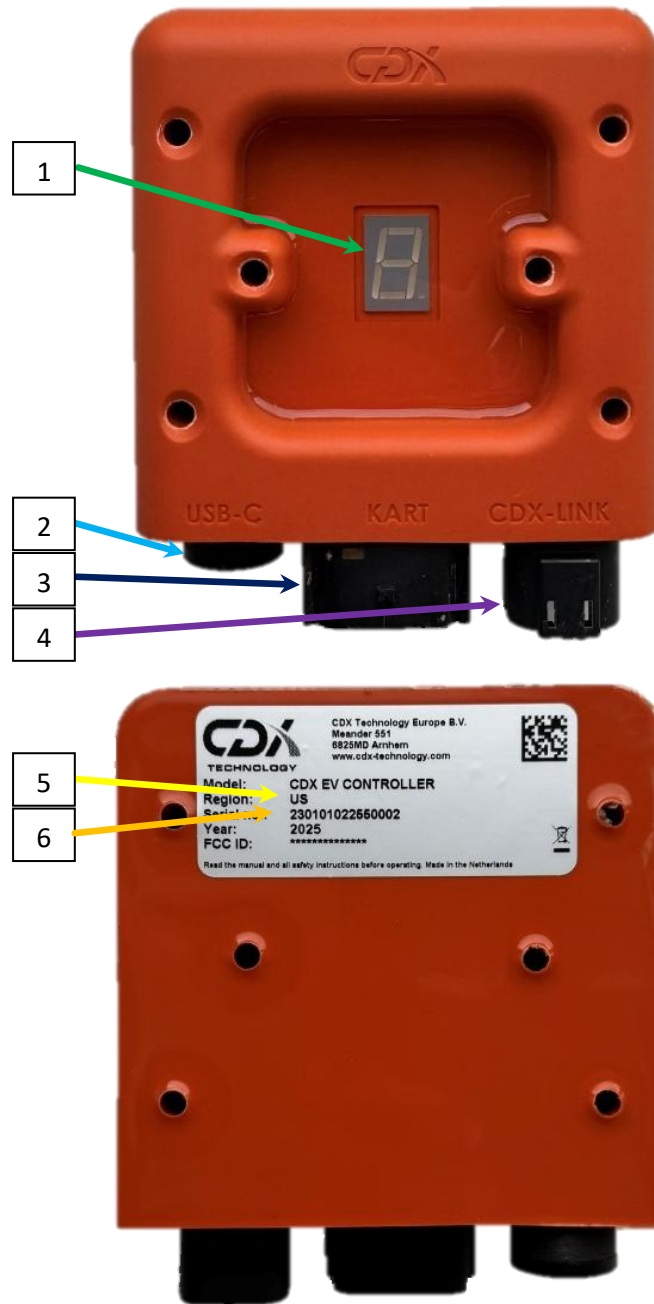

Figure 2: CDX EV Controller with important parts highlighted

NUMBER	DESCRIPTION
1.	Speed setting display
2.	USB connector
3.	Kart connector
4.	CDX-Link connector
5.	Region
6.	Serial number

## 2 Installation Guide

In this chapter the installation of the EV controller is detailed. How to mount the EV controller properly, while maintaining the optimal radio reception. Additionally, the connector functions and pinout are shown, as well as the digital outputs used to control the speed of the kart.

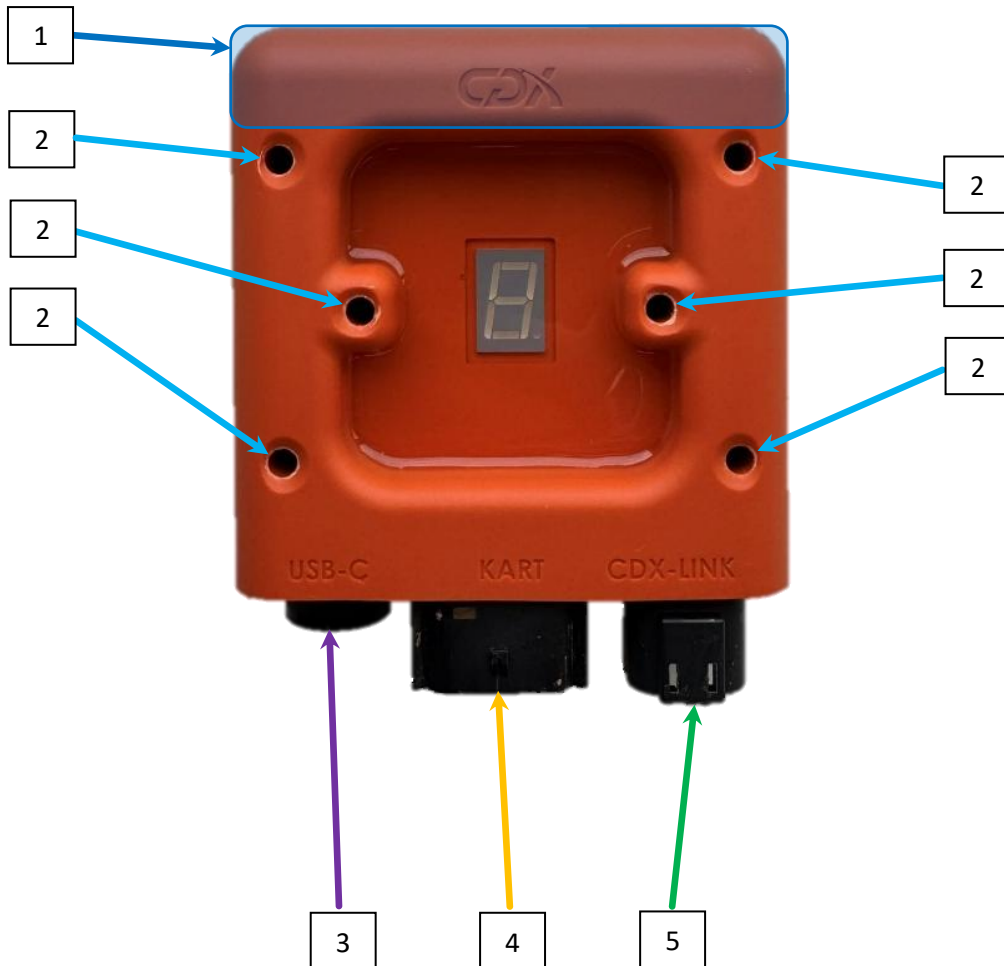

Figure 3: CDX EV Controller with main components highlighted

NUMBER	DESCRIPTION
1.	PCB antenna location
2.	M5 mounting holes
3.	USB-C connector
4.	Kart connector
5.	CDX-Link connector

## 2.1 Mounting instructions

The EV controller has a total of 6 M5 mounting holes, shown in Figure 3, used for mounting the device on a flat surface. The 6 mounting holes can be used to mount the device with M5-sized bolts and nuts. Additionally, if preferred, the device can be mounted with tie wraps. Do not overtighten the mounting of the device, as this may deform it and prevent proper functioning.

To achieve the optimal radio reception performance from the EV controller, it should be placed as high as possible on the kart. The region of the antenna, which is shown in Figure 3, should not be blocked by metal and other RF interfering obstacles such as cables.

## 2.2 Connector overview

The EV controller contains 3 connectors, shown in Figure 3. a USB-C connector, a Kart connector and a CDX-Link connector. The Kart connector is required to limit the speed of the kart. The other connectors are for optional extra functionality and not necessary for limiting the speed of the kart.

### 2.2.1 Kart connector

The Kart connector is an MX120G automotive connector, type 36783-1201 shown in Figure 6. The visual pinout of the Kart Connector is shown in Figure 5. The counterpart connector (female) is the 36792-1201, which is shown in Figure 4.

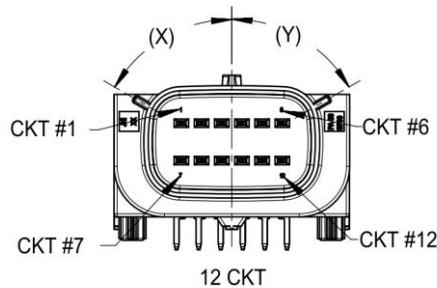

Figure 6: 3D model 36783-1201

Figure 5: Schematic view 36783-1201

Figure 4: 3D model 36792-1201

PIN	FUNCTION
1.	Battery +
2.	Kart output 3 (digital)
3.	Kart output 2 (digital)
4.	Input 2 (digital)
5.	Kart output 4 (digital)
6.	GND for digital signals
7.	Battery -
8.	Kart output 1 (digital)
9.	Input 1 (digital)
10.	Unbrick - for service use
11.	CAN low - optional
12.	CAN High - optional

### 2.2.2 CDX Link connector

A 4 pin automotive connector, DTF13-4P (Figure 9), is used for the CDX link connector. Figure 8 visually shows the pinout of the CDX link connector. The counterpart connector (female) is the DT06-4S (Figure 7).

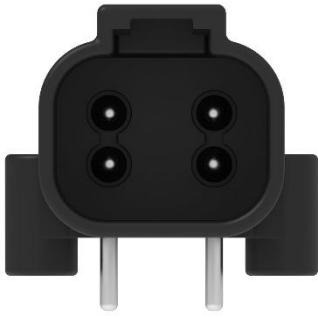

Figure 9: 3D model DTF13-4P

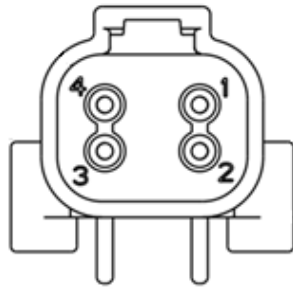

Figure 8: Schematic view DTF13-4P



Figure 7: 3D model DT06-4S

PIN	FUNCTION
1.	GND
2.	RS232 TX
3.	RS232 RX
4.	Vout

See Chapter 5 (Technical data) for more details.

### 2.2.3 USB-C

The USB-C connector can be used to configure the EV controller, which is explained in Chapter 4 (System Configuration). The counterpart connector (male) needs to be a USB 2.0 data cable, USB A to USB C cable. Any other cable that is used for USB-C connection is not recommended and proper working is not guaranteed. The EV controller comes with a sealing screw on the USB-C connector. To prevent contamination in the connector, the screw should remain in place during normal use, otherwise normal operation is not guaranteed.

### 2.3 Digital outputs

The EV controller has 4 digital outputs, each digital output can be configured to work in tri-state. Tri-state can assume a high output (logical 1), a low output (logical 0) or high impedance (floating). This configuration can be done by user, the process of which is described in Section 4.1 (Configuration terminal). See Chapter 5 (Technical data) for technical details.



### 3 Operating instructions

This chapter describes how the EV controller operates. Figure 10 visually shows the typical configuration. The safety radio message is received from an user that transmits speed control messages by a CDX Remote. See the corresponding user manual for further information.

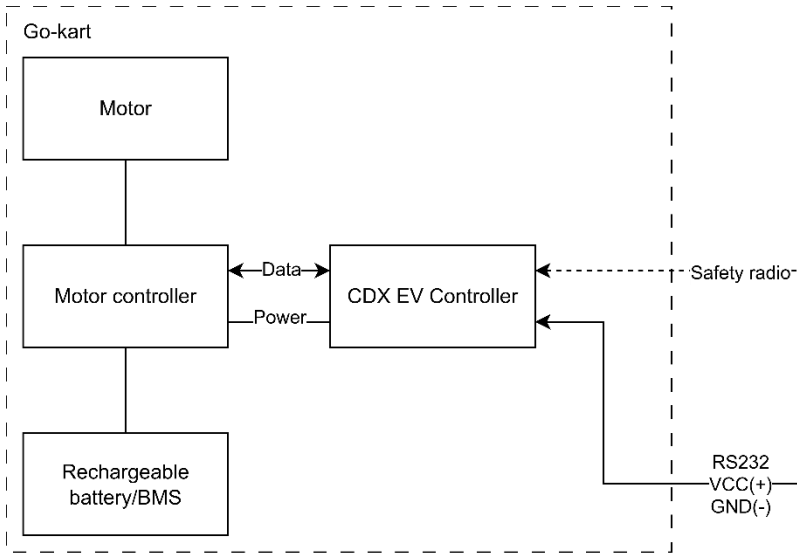

Figure 10: Typical configuration EV controller

#### 3.1 Speed restriction

The EV controller communicates speed presets to the motor controller using 4 digital outputs. The value of each individual digital output is determined based on the speed-preset currently active on the CDX EV Controller defined by the user-configurable switch table.

#### 3.2 7-segment display

The 7-segment display is used to display the current speed setting active on the CDX EV Controller. The speed setting can range from speed 0 (stop) to 8. The display is also used to indicate that the radio is functioning properly. This is done by toggling the dot in the 7-segment display when a valid radio message is received.

#### 3.3 Segment Slowdown

Segment slowdown is a feature of the CDX EV Controller that allows slowdown in certain sections of the track. There are additional CDX devices required to use segment slowdown. The CDX Loop is required to create track segments and the CDX Sensor is required to detect the track segments. This enables the EV Controller to automatically slow down when driving over the start of a segment, and to return to its previous speed setting on the end of a segment.

When the CDX EV Controller receives two different speed commands—one from the CDX Sensor and one from the CDX Phone/Tablet transceiver—the lowest speed is applied. This ensures that slowdown segments cannot be overridden by a remote command requesting a higher speed, and vice versa.

## 4 System Configuration

The CDX EV Controller has various features, some of which are enabled when using CDX products and some that interface with the CDX-Link port. In this paragraph the information about segment slowdown, Track ID and Track PIN are noted.

### 4.1 Configuration terminal

When the USB is connected, the CDX EV Controller can be configured using a serial terminal program. The terminal program can be used to alter the switch table. Additionally, it can also be used to alter the Kart ID and Track IDs of the CDX EV Controller.

#### 4.1.1 Track ID and Track PIN

The Track ID and Track PIN feature allows the logical segmentation of multiple CDX EV controllers into separate control groups.

By default, the Track-ID is set to '0000' and Track-PIN is set to '0000'. In this default configuration, the CDX EV controller accepts speeds commands from all compatible control interfaces, regardless of the Track ID and Track Pin settings of the remote. This default behavior allows unrestricted communication during initial setup and commissioning.

The use of a Track ID and Track-PIN is recommended to be used when two separate groups of karts (for example, track 1 and track 2) are operating simultaneously within the same go-kart facility and separate control of each group is required.

The Track ID and Track Pin can also be used to limit control access to a defined group of controllers by updating these parameters when required.

The Track-ID and Track-PIN must be configured in the configuration tool and stored within the CDX EV controller. After configuration, the corresponding Track ID and Track PIN must also be configured in the control interface application to control the associated CDX EV Controllers.

#### 4.1.2 Segment Slowdown

The speed limits per track segment are configured in the CDX Sensor and CDX Loop. See the corresponding user manual for further information.

### 4.2 Switch table

The switch table is the configuration of what outputs of the EV controller are set to High, Low or Floating at every speed. This switch table is configured using the configuration terminal. See the corresponding user interface manual for further information. For more details see Chapter 5 (Technical data).

For example, if the switch table is configured as shown in Table 1. When the EV controller is set to speed 1, output 2 to output 4 will be set to Low and output 1 will be set to High. If the connected motor controller has the corresponding switch table, speed 1 is detected.

	Output1	Output2	Output3	Output4
<b>Speed 0</b>	L	L	L	L
<b>Speed 1</b>	H	L	L	L
<b>Speed 2</b>	L	H	L	L
<b>Speed 3</b>	L	L	H	L
<b>Speed 4</b>	L	L	L	H

Table 1: Switch table example

## 5 Technical data

This chapter presents the technical data in tables by category.

Electrical characteristic	Min	Typ.	Max	Unit
Operational voltage	8	24	60	V (DC)
Power consumption		500		mW
Current draw (48V)		10		mA
Digital output High		14		V (DC)
Digital output Low		0		V (DC)
CDX-Link Vout		14		V (DC)
CDX-Link RS232 TX High (logical 0)	5	5.4		V (DC)
CDX-Link RS232 TX Low (logical 1)		-5.4	-5	V (DC)
CDX-Link RS232 RX High (logical 0)	3		15	V (DC)
CDX-Link RS232 RX Low (logical 1)	-15		-3	V (DC)
KART interface digital outputs			±10	mA

Environmental characteristic	Min	Typ.	Max	Unit
Operational temperature <sup>1</sup>	0		65	°C
Storage temperature	-20		80	°C

Radio characteristic	Unit	
Receiving radio frequency	869 (Europe), 908 (North America)	MHz
Radio modulation	Direct sequence spread spectrum (DSSS)	
Radio antenna	PCB antenna	
Radio antenna gain	4.85	dBi

Physical characteristic	Unit	
Dimensions (Length × Width × Height)	117 × 100 × 35	mm
Mounting hole diameter	5	mm
Housing material	Polyurethane (PUR)	

<sup>1</sup> Upon request, wider temperature ranges are available.

### 5.1 Mounting points

To mount the CDX EV Controller, 6 M5 holes are present. The location and dimensions can be seen in Figure 11.

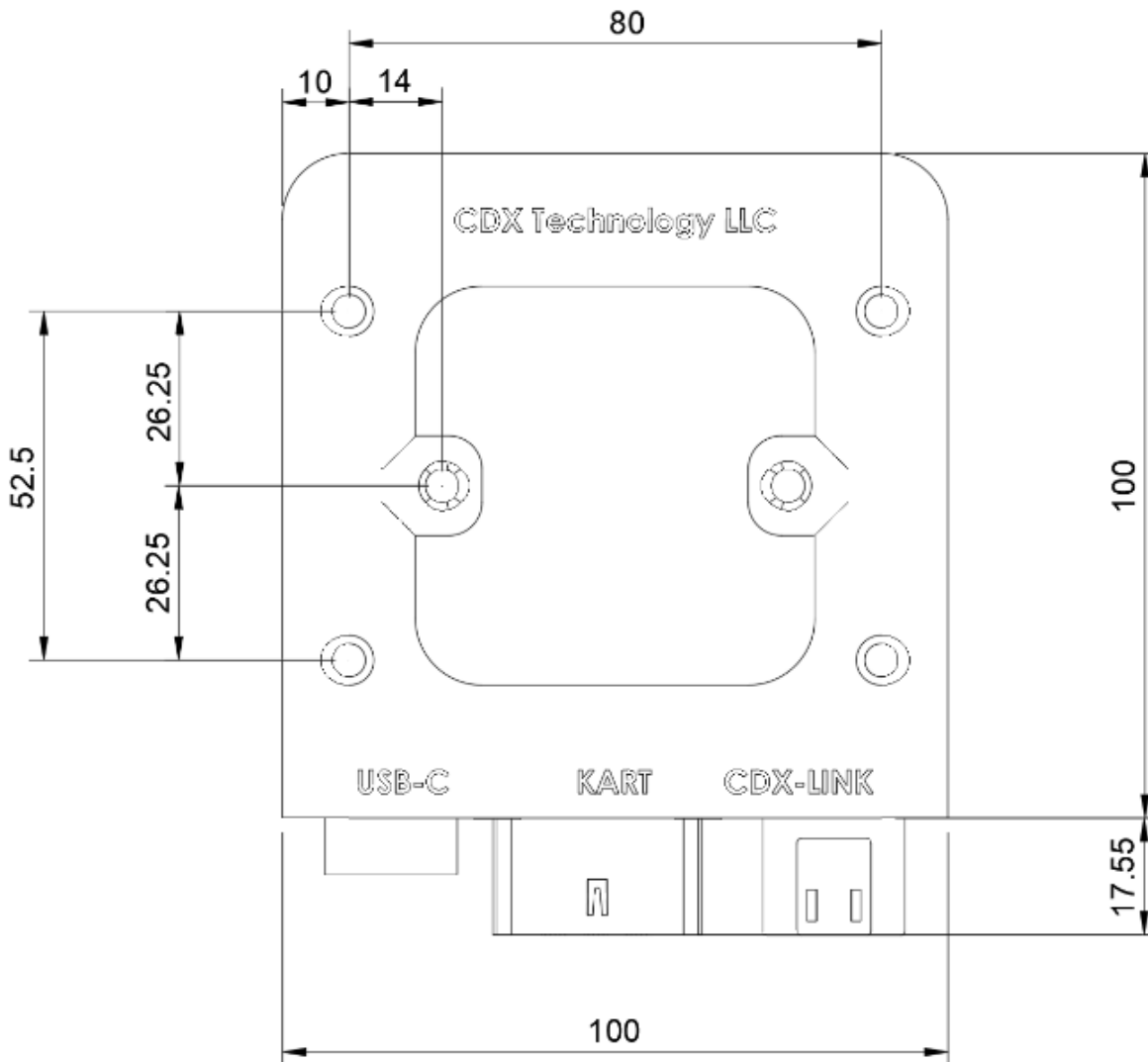

Figure 11 CDX EV Controller size schematic

The device is provided with six mounting holes suitable for use with M5 bolts and nuts. It is recommended to use a minimum of three mounting holes to securely attach the device.

As an alternative, the device may be mounted using tie wraps, provided that the mounting method securely retains the device during operation.

Do not overtighten the mounting hardware, as excessive force may deform the enclosure and affect device operation.

The CDX EV Controller should not be mounted in close proximity to the motor or other high-current components, as this may adversely affect radio communication. Further installation information can be found in Chapter 2, Section 2.1 (Mounting instructions).

