

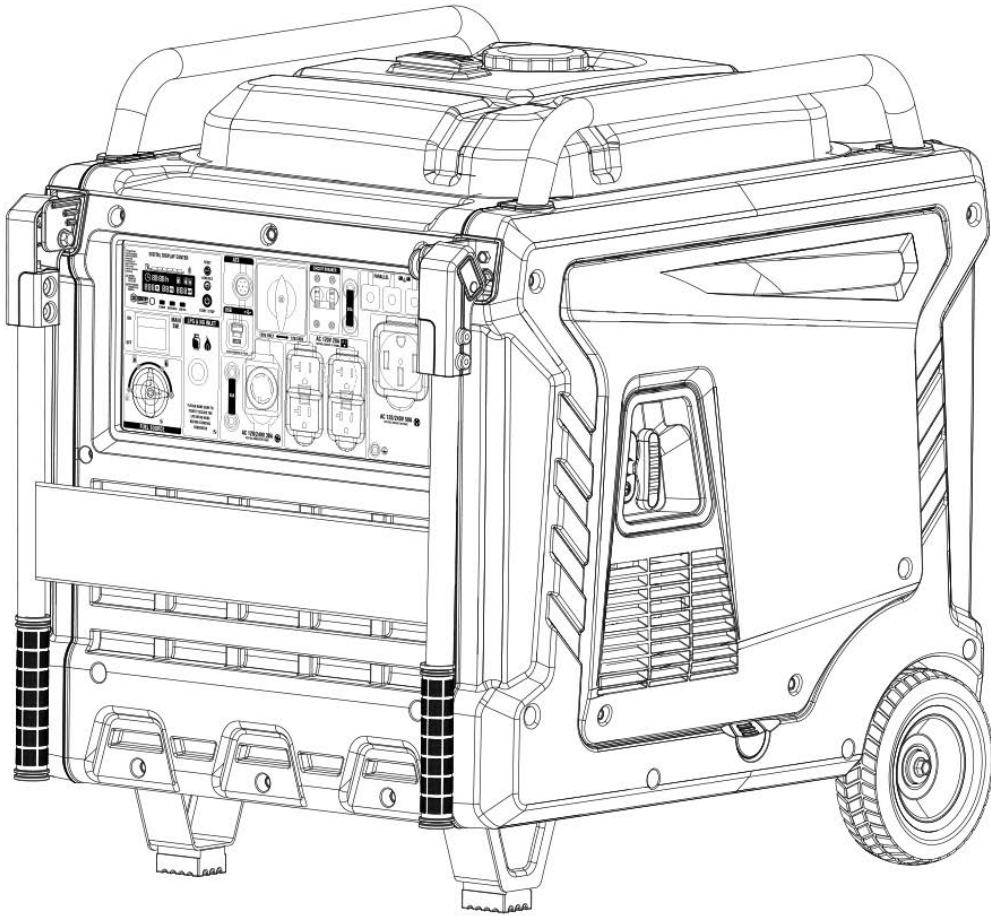

Model: PGD125TiSRCO

# 12500 Watt Tri-Fuel Inverter Generator

## OPERATOR'S MANUAL



### Caution:

- Before using your generator, please read this manual carefully to understand proper use.
- Keep this manual with the generator.



**WARNING:** This product contains chemicals, including lead, known to the State of California to cause cancer, birth defects or other reproductive harm. Wash hands after handling. For more information, visit [www.P65warnings.ca.gov](http://www.P65warnings.ca.gov).



**DO NOT RETURN TO STORE!**

**HAVE QUESTIONS OR NEED SERVICE?**



866-591-8921



[support@pulsar-products.com](mailto:support@pulsar-products.com)

# Table of Contents

Table of Contents .....	1	Preparation.....	6
Introduction .....	1	Operation.....	11
Safety Warnings and Notices .....	1	Maintenance .....	15
Safety Instructions .....	2	Specifications .....	19
Components.....	4	Troubleshooting .....	20
Control Panel .....	5	Electrical Schematic.....	23

## Introduction

Thank you for choosing **Pulsar Products!**

This manual provides instructions on how to safely and correctly operate your generator. Please read and fully understand this manual before using your generator. If you have any questions, contact us at **866.591.8921 (Monday–Friday)** or at **support@pulsar-products.com** before using your generator.

All details and images in this manual are believed to be accurate at the time of publication. Pulsar Products reserves the right to make updates to this manual at any time. For the latest updates, please contact Pulsar Support at **866.591.8921** or **support@pulsar-products.com**.

This manual is a permanent part of the generator. If the generator is resold, please include this manual with it.

## Safety Warnings and Notices

### WARNING: Save This Manual for Future Reference

This manual contains important information regarding the safety, operation, maintenance, and storage of this product. Before use, you must read and fully understand all cautions, warnings, instructions, and product labels. Failure to do so could result in serious personal injury and/or property damage.

## Safety Definitions

 This safety alert symbol appears with most safety statements. It means to pay attention and be alert, your safety is involved! Please read and abide by the message that follows the safety alerts symbol.

### DANGER

**DANGER** indicates an imminently hazardous situation which, if not avoided, will result in death or serious injury.

### WARNING

**WARNING** indicates a potentially hazardous situation which, if not avoided, could result in death or serious injury.

### CAUTION

**CAUTION** indicates a potentially hazardous situation which, if not avoided, may result in minor or moderate injury. It may also be used to alert against unsafe practices.

### NOTICE











**Failure to follow the instruction may result in the damage to your generator and other property.**

# Safety Instructions

## Safety Symbols

Follow all safety information provided in this manual and on the generator.

Before operating the generator, you must read and understand this manual fully and familiarize yourself with safe operating practices.

SYMBOL	DESCRIPTION
	Safety Alert Symbol
	Electrocution Hazard
	Asphyxiation Hazard
	Burn Hazard. DO NOT touch hot surfaces.
	Electrical Shock Hazard
	Fire Hazard
	Maintain Safe Distance
	Lifting Hazard
	Read Manufacturer's Instructions
	DO NOT Operate in Wet Conditions
	Grounding. Consult a qualified electrician to determine the necessary grounding requirements before operating this product.

## Safety Precautions



Operate this product **ONLY** outdoors, far away from windows, doors, and vents, to reduce the risk of carbon monoxide gas buildup, which could accumulate and be drawn into occupied spaces.

**DO NOT** operate this product under the influence of alcohol, while exhausted or sleep-deprived, when drowsy from medications, or under any condition that could impair your judgment or prevent safe operation.

**Avoid operating this product under the following circumstances:**

1. When the ground is slippery or when other conditions exist which might make it not possible to maintain a steady posture.
2. At night, at times of heavy fog, or at any other times when your field of vision might be limited, it would be difficult to gain a clear view of the area.
3. During rainstorms, during lightning storms, at times of strong or gale-force winds, or at any other times when weather conditions might make it unsafe to use this product.

**POISONOUS GAS HAZARD:** Engine exhaust contains carbon monoxide, a poisonous gas that could kill you in minutes. You **CAN NOT** smell it, see it, or taste it. Even if you do not smell exhaust fumes, you could still be exposed to carbon monoxide gas.



# Safety Instructions

- **Never** operate this product in enclosed or partially enclosed spaces, including homes, garages, sheds, basements, or crawlspaces, even if using fans or open windows and doors for ventilation. Carbon monoxide can build up quickly and linger for hours, even after the engine is off.
- **Install battery-operated or plug-in carbon monoxide alarms with battery backup** as per the manufacturer's instructions. **Most smoke alarms do not detect carbon monoxide.**
- **Position the exhaust downwind** and direct the exhaust away from occupied spaces. If you experience symptoms like dizziness, weakness, or nausea, immediately turn off the engine, move to fresh air, and seek medical attention, these may indicate carbon monoxide poisoning.

## WARNING

**Never store fuel cans or refill the fuel tank in areas with boilers, stoves, wood fires, electrical sparks, welding sparks, or any other sources of heat or fire that could ignite the fuel.**

**Smoking while operating the generator or refilling its fuel tank is extremely dangerous. Never smoke or vape while working with your generator.**

**When refilling the fuel tank, always turn off the engine first. Carefully inspect the area to ensure there are no sparks or open flames nearby before refueling. If any fuel spills occur during refueling, use a dry rag to clean up the spills before restarting the engine.**

**After refueling, securely screw the fuel cap back onto the tank and move the generator at least 3 meters (10 feet) away from the refueling area before restarting the engine.**

**Additionally, be aware that starter cord kickback (rapid retraction) can pull your hand and arm toward the engine faster than you can release it, potentially causing broken bones, fractures, bruises, sprains, or other serious injuries. To prevent this, always pull the recoil handle until resistance is felt, (compression stroke), let it retract, and then pull it again swiftly and fully.**

## WARNING



**Fuel and its vapors are extremely flammable and explosive which could cause burns, fire, or explosion resulting in death or serious injury and/or property damage.**

## When Adding or Draining Gasoline

**Turn the generator engine OFF and let it cool for at least 2 minutes before removing the fuel cap. Loosen the cap slowly to relieve any pressure in the tank.**

- Fill or drain fuel tank outdoors.
- DO NOT overfill the tank. Allow space for fuel expansion.
- If fuel spills, wipe it up and let the area dry before starting the engine.
- Keep fuel away from sparks, open flames, heat, and other ignition sources.
- Check fuel lines, tank, cap, and fittings frequently for cracks or leaks; replace them if necessary.
- DO NOT smoke or vape anything.

## Before Starting the Generator

**Before starting your generator, you must read and understand this manual and familiarize yourself with safe operating practices. Improper treatment of the generator could damage it and shorten its lifespan.**

Keep the handles dry, clean, and free of oil or fuel residue.

## ⚠ WARNING

Never touch the muffler, spark plug, or other metal parts of the inverter generator while it is running or immediately after stopping. Doing so could result in serious burns or electrical shock.

## When Starting the Generator

Ensure the spark plug, muffler, fuel cap, and air cleaner are properly in place.

**DO NOT** crank the engine with the spark plug removed.

## NOTICE

- Use the generator only for its intended applications.
- Operate the generator only on solid, level surfaces.
- **DO NOT** insert any objects through the cooling slots.
- **DO NOT** expose the generator to excessive moisture, dust, dirt, or corrosive vapors.
- If connected devices overheat, turn them off and disconnect them from the generator immediately.

### Shut off the generator if:

- Electrical output is lost.
- Equipment sparks, smokes, or emits flames.
- The unit vibrates excessively.

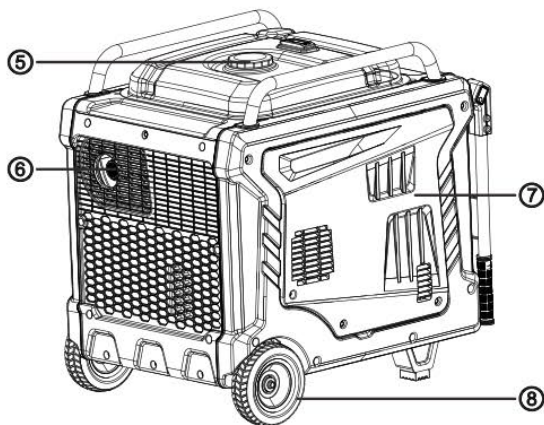
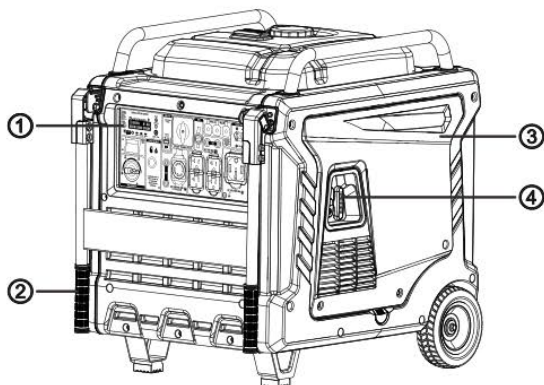

- ① **Control Panel:** Contains the electrical outlets and operational controls for the generator.
- ② **Transport Handle:** Facilitates easy transport of the generator.
- ③ **Right Side Cover**
- ④ **Recoil Start:** Pull to start.
- ⑤ **Fuel Tank Cap:** Remove this cap to add gasoline to the generator.
- ⑥ **Muffler and Spark Arrestor:** The spark arrestor prevents sparks from exiting the muffler, enhancing safety.
- ⑦ **Left Side Cover**
- ⑧ **Wheel(2):** Allows transportation of the generator.

# Control Panel

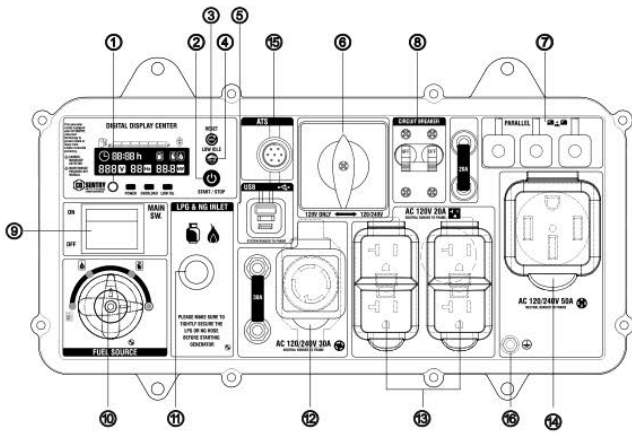

⑭ **120V/240V AC 50A 14-50R Outlet**

⑮ **ATS Outlet:** Allows you to connect a ST Switch (sold separately) to the generator.

## THE ILLUSTRATION OF ATS PORT

### PIN 1 — Battery + Connection

Connects to the positive terminal of the generator battery.

Function:

1. Supplies DC control power to the ATS.
2. When utility AC power is present, the ATS charges the generator battery through this pin.

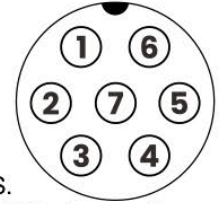

### PIN 2 — Ground (GND)

Connects to the generator chassis or the negative battery terminal, serving as the common reference ground for all signal circuits.

### PIN 3 — Start/Stop Signal

Connects to the start/stop signal wire (typically blue) of the generator's push-button switch.

Control logic:

- **To Start:** When the generator is off, the ATS connects Pin 3 and Pin 2 for 0.5 to 5 seconds, then disconnects.
- **To Stop:** When the generator is running, the ATS again connects Pin 3 and Pin 2 for 0.5 to 5 seconds, then disconnects.
- **Important Note:** The signal takes effect at the moment when the connection between Pin 3 and Pin 2 is broken, not during the connection period. This momentary signal is used to toggle the generator's state based on its current status.

### PIN 4 — Emergency Stop (Flameout Control)

Connects to the flameout wire (usually black/red) of the generator's ignition circuit.

Function:

- When the emergency stop is triggered, the ATS connects Pin 4 and Pin 2, immediately cutting off ignition.
- The generator shuts down instantly and cannot be started again if the emergency stop switch is not restored.

### PIN 5 — Not in Use

### PIN 6 — Generator Running Status Feedback

Connects to a DC 12V+ signal (e.g., a USB port, cigarette lighter socket, or internal 12V logic output) that becomes energized when the generator is running.

Purpose:

- The ATS uses this voltage signal to determine whether the generator is running or stopped.

### PIN 7 — Not in Use

⑯ **Ground Terminal:** The ground terminal is used to externally ground the inverter.

- ① **CO Alarm:** Flashing red light: dangerous levels of carbon monoxide gas have built up leave immediately until the area has aired out. Move the generator to a well-ventilated area before operation. Flashing yellow light: carbon monoxide sensor malfunction. Sensor needs service.
- ② **One-Push Start Button:** Press the button to start and stop the engine.
- ③ **Reset:** If the inverter is overloaded, the reset breaker will trip. The engine will continue to run, but there will be no output from the inverter. Unplug all devices then press the button to reset it.
- ④ **Low Idle:** When pressed to the ON position, the engine will sense the load needed and run at a slower RPM to save fuel.
- ⑤ **USB Duplex:** 5V DC, Type-A and Type-C connectors.
- ⑥ **Voltage Selector:** Switch between 120V and 240V voltage as required.
- ⑦ **Parallel Connectors:** To increase AC power output, the connector sockets are used to connect the two same generators with special paralleling cords. The connector sockets are only used for communication between the inverters, they cannot be used for AC power output.
- ⑧ **Circuit Breaker:** AC circuit breakers control the output of all AC sockets to protect against overload or short circuit of the generator.
- ⑨ **Main Switch:** Manage battery power and shutdown. Tip: If you do not intend to use the generator for more than 7 days (168 hours), press the main switch to the "OFF" position, to prevent battery drain.
- ⑩ **Fuel Source Selector**
- ⑪ **LPG/NG Inlet**
- ⑫ **120V/240V AC 30A L14-30R Outlet**
- ⑬ **120V AC 20A 5-20R Outlet**

# Preparation

## Add Engine Oil

### NOTICE

Failure to follow this instruction may damage your generator.

If you are operating the generator in extreme temperatures, refer to the following chart for the recommended oil type.

Recommended Engine Oil Type	
10W-30	→
5W-30	←
10W-40	→
5W-30 Synthetic	→
°F	-20 0 20 40 60 80 100 120
°C	-28.9 -17.8 -6.7 4.4 15.6 26.7 37.8 48.9
Ambient temperature	

The generator is shipped without engine oil. Do not start the engine without ensuring it has sufficient oil.

1. Place the generator on a solid, flat, level surface.
2. On the left side of the generator, loosen the screws and remove the maintenance cover.

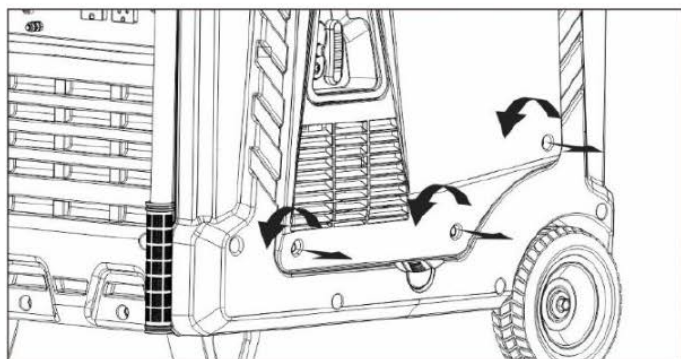

3. Remove the oil fill cap/dipstick to check or add oil. Reattach the cover and tighten the screws securely.

4. Using a funnel, as needed, add the appropriate type of oil until the oil level is at the proper level. SAE 10W-30 is recommended for general use. DO NOT OVERFILL. Replace the oil fill cap/dipstick and secure the maintenance cover.

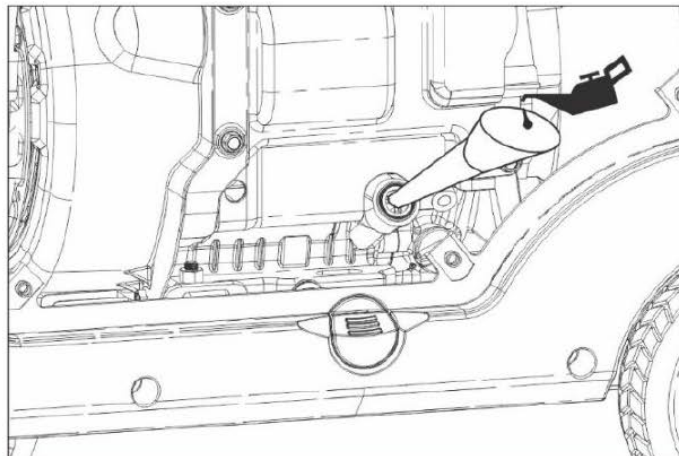

5. Check engine oil level daily and add as needed.

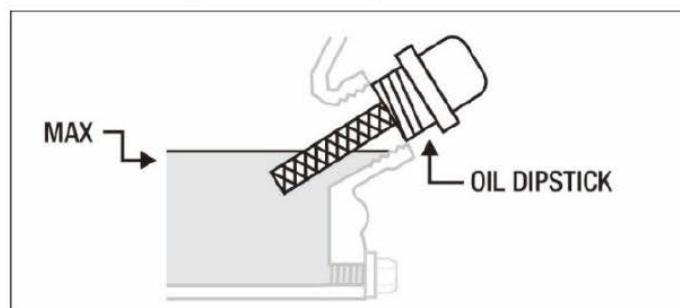

### NOTICE

#### Recommended Engine Oil:

- Type: SAE 10W-30
- Oil Grade: API Service SE type or higher
- Engine Oil Capacity: 1.1 L (37 fl. oz)

Residual oil from the factory may remain in the engine. Add oil slowly to prevent overfilling. Once oil has been added, the oil level should be 1-2 threads below the fill hole. DO NOT screw in the dipstick while checking the oil level.

### NOTICE

Check the oil level frequently during the break-in period. Refer to the Maintenance section for recommended service intervals.

### CAUTION

This engine is equipped with a low oil shut-off and will stop when the oil level in the crankcase falls below a critical level.

# Preparation

## NOTICE

The first 5 hours of run time are the break-in period for the engine. During the break-in period stay at or below 50% of the running watt rating and vary the load occasionally to allow stator windings to heat and cool. Adjusting the load will also cause engine speed to vary slightly and help seat piston rings. After the 5-hour break-in period, let the engine cool, then change the oil.

## NOTICE

Synthetic oil may be used after the 5-hour initial break-in period. Using synthetic oil does not increase the recommended oil change interval. Full synthetic 5W-30 oil will aid in starting in cold ambient < 41°F (5°C) temperatures.

## Add Gasoline

### ⚠ WARNING



**TO PREVENT SERIOUS INJURY FROM FIRE:**  
Fill the gasoline tank in a well-ventilated area away from ignition sources. If the engine is hot from use, shut the engine off and wait for it to cool before adding gasoline. Do not smoke.

1. Make sure the generator is on a solid, flat, level surface.
2. Unscrew the fuel cap and set it aside.
3. Slowly add gasoline to the fuel tank. Be careful not to over fill. The fuel gauge on the top of the fuel tank indicates how much gasoline is in the generator fuel tank.

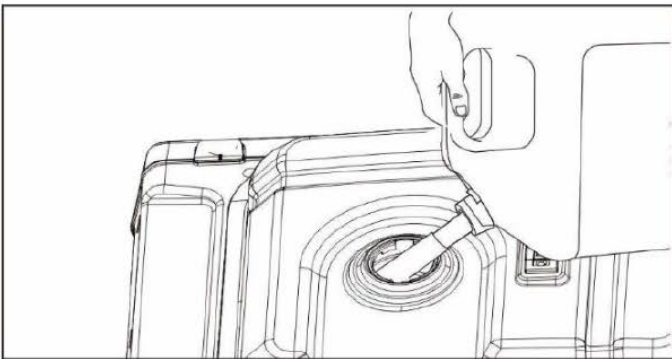

4. Replace the fuel cap and wipe up any spilled gasoline with a dry cloth then remove the cloth from the area.

### ⚠ DANGER

Do not overfill the gasoline tank. Overfilling can result in a fire, explosion, or death.

### ⚠ WARNING

Gasoline can expand. Do not fill the gasoline tank to the top. Leave a minimum of 1.5 inches open space. Gasoline vapor is highly flammable. Do not fill the tank near an open flame. Always check for gasoline spills.

- To ensure that the generator runs smoothly use only FRESH 87 octane gasoline.
- Never use an oil/gasoline mixture.
- Never use old gasoline.
- Avoid getting dirt or water in the gasoline tank.
- Gasoline can age in the tank and make it hard to start the generator in the future.
- Never store the generator for extended periods of time with gasoline in the tank.

## Connecting an LPG Tank

### NOTICE

- Propane tanks that use a liquid withdrawal system, cannot be used on these models.
- Confirm that the re-qualification date on the tank has not passed.
- DO NOT use the included LPG hose for any other appliances.

# Preparation

## NOTICE

- All new propane tanks must be purged of air and moisture prior to filling. Used propane tanks that have not been plugged or kept closed must also be purged. The purging process should be done by a propane tank supplier (propane tanks from an exchange supplier should have been purged and filled properly).
- ALWAYS position the propane tank so the connection between the valve and the gas inlet will not cause sharp bends or kinks in the hose.

## WARNING

Explosion hazard. DO NOT start generator if you smell propane ALWAYS fully close the propane tank valve and disconnect the LPG hose from the generator when not in use.

1. Turn the generator OFF and place on a flat surface in a well-ventilated area.
2. Verify that the propane tank valve is in the fully closed position.

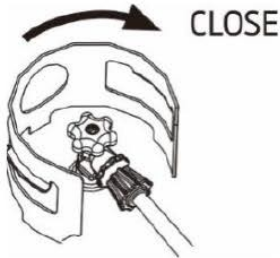

3. Remove the cap or cover on the generator LPG/NG gas inlet.
4. Tighten the black coupler onto the tank valve, and hand-tighten it (clockwise).

**IMPORTANT:** DO NOT use thread seal tape or any sealant to seal the LPG hose to tank connection.

5. Push back the quick connector collet of the LPG hose, insert it onto the generator LPG/NG inlet, release the quick connector collet, and check for a secure connection.

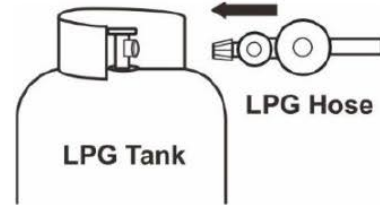

6. Turn the LPG tank valve to the fully open position. Check all connections for leaks by wetting the fittings with soapy water. Bubbles that appear or bubbles that grow indicate that a leak exists. If a leak exists at a fitting, turn the LPG tank valve to the fully closed position and tighten the fitting. Open the LPG tank valve and recheck the fitting with the soapy water solution.

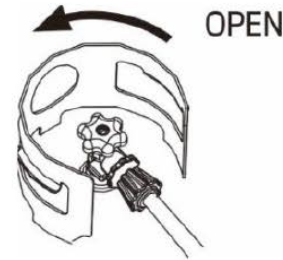

## Connect the Natural Gas (NG) Supply Line

### DANGER

Fire and explosion hazard. Never connect or disconnect the natural gas hose while the engine is running. Do not smoke or create sparks while handling natural gas. Always turn the engine off and allow the generator to cool for at least five minutes before connecting to natural gas.

### WARNING

Never use a natural gas supply line, natural gas hose, or any other fuel item that appears to be damaged.

### WARNING

- To reduce the risk of injury, perform a leak test whenever the natural gas hose is reconnected.
- Explosion hazard. If you smell natural gas, do not start the generator. Always completely close the natural gas supply line valve and disconnect the natural gas (NG) hose from the generator when not in use.

# Preparation

1. Turn the generator off and allow the engine to cool for at least five minutes.
2. Verify that the gas is turned off at the natural gas supply line.

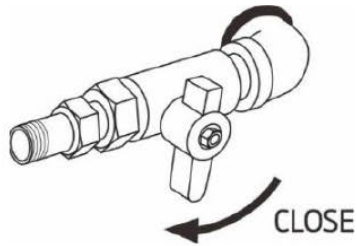

3. Completely unwrap and straighten the natural gas hose to prevent kinks.
4. Contact your local gas company for guidance on accessory connection to a natural gas line. Your qualified contractor must minimally ensure the pipe supply line threads are clean and in good condition. Pipe connections must be made using a gas-rated 'dope' or PTFE tape.

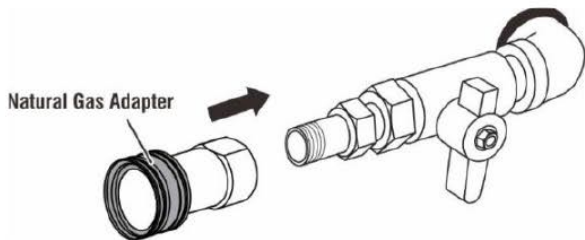

5. Pull the quick connect collet rearward, insert the natural gas hose nipple, then release the collet; ensure a solid connection is made.

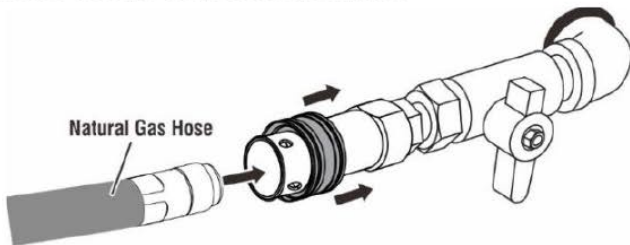

6. Push back the quick connect collet of the natural gas hose, insert it onto the generator LPG/NG inlet, release the quick connect collet, and check for a secure connection.

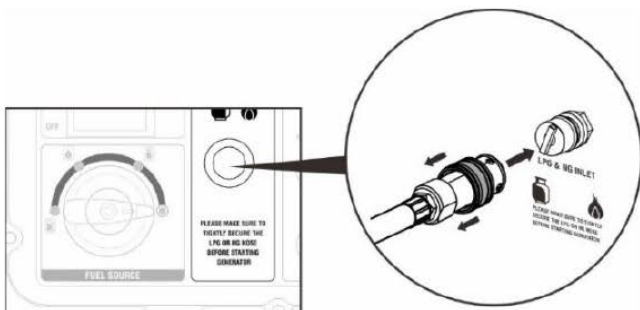

7. Turn the natural gas (NG) supply line valve to the fully open position. Check all connections for leaks by wetting the fittings with soapy water. Bubbles that appear or bubbles that grow indicate that a leak exists. If a leak exists at a fitting, turn the natural gas (NG) supply line valve to the fully closed position and tighten the fitting. Open the natural gas (NG) supply line valve and recheck the fitting with the soapy water solution. If the leak continues or if the leak is not at a fitting then **DO NOT** use the generator and contact an authorized Pulsar service center.

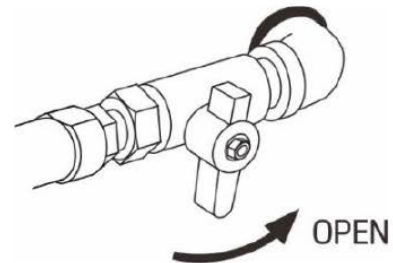

## Connecting the Battery

1. On the left side of the generator, loosen the screws and remove the cover.

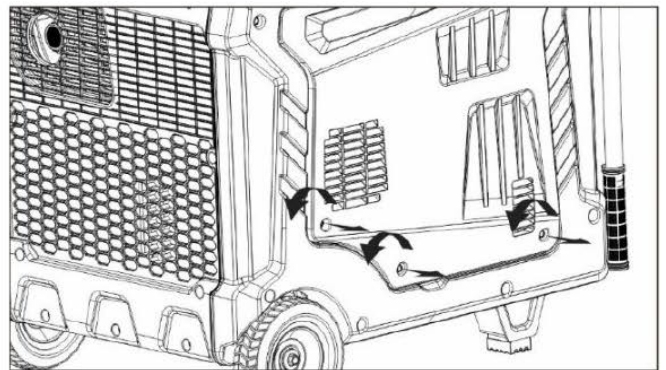

2. Verify that the rubber battery strap is firmly securing the battery in place. If loose, pull on the strap and hook it onto the mounting base.  
**Note:** If the strap is loose behind the battery, remove the battery, reconnect the strap, replace the battery, then thread the strap under the battery quick-connect cables.

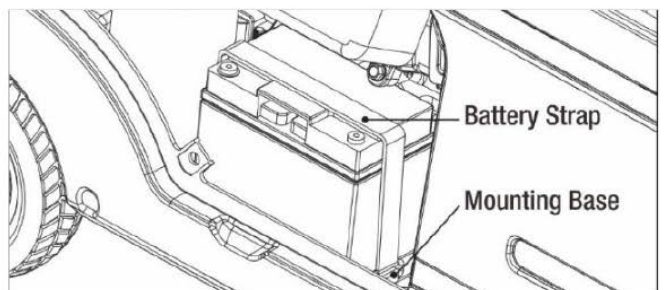

# Preparation

3. A quick-connect battery plug is pre-installed on the battery.

Remove the cable tie securing the plugs, align colors, then push firmly to connect them.

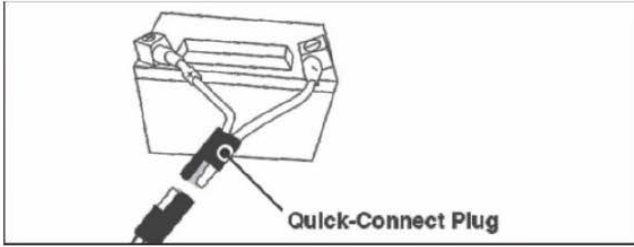

4. Align the tabs on the bottom of the battery access cover with the generator case then push to reinstall the cover.

**Note:** The generator is equipped with a battery charging feature. Once the engine is running, a small current will slowly recharge the battery.

## Grounding the Generator

Attach grounding wire (if required by code)

- Ground the generator by tightening the grounding nut against a grounding wire.
- Connect the other end to a suitable copper grounding rod that is driven into the earth at the correct depth, per local code.

A generally acceptable grounding wire is a No. 12 AWG (American Wire Gauge) stranded copper wire.

Grounding codes can vary by location. Please contact a local electrician to check the grounding regulations for your area.

### **⚠ WARNING**

Failure to properly ground the generator can result in electrocution.

## Low Oil Indicator

### ⚠ WARNING

NEVER operate the generator inside any building, garage, basement, crawlspace, shed, or enclosure, including the generator compartment of a recreational vehicle.

NEVER operate or start the generator in the back of an SUV, camper, trailer, truck bed (regular sides, flat or other configuration), under staircases, stairwells, next to walls or buildings, or any other location that could limit airflow or trap exhaust.

DO NOT operate or store the generator in wet weather conditions such as rain or snow. Using a generator in wet conditions could result in serious injury or death due to electrocution.

Generators must have a minimum of 5 feet (1.5 m) of clearance from all combustible material.

Generators must also have a minimum of 5 feet (1.5 m) of airflow clearance on all sides to allow for adequate cooling, maintenance, and service. Always place the generator in a well-ventilated area. NEVER place the generator near air intake vents or where exhaust fumes could be drawn into occupied or confined spaces.

Always carefully consider wind and air currents when positioning the generator.

Always allow generators to properly cool before transport or for storage purposes.

Failure to follow proper safety precautions may result in personal injury, damage to the generator, and void your warranty.

### ⚠ WARNING

During operation, the muffler and exhaust fumes will become hot. If there is inadequate cooling space or if the generator is blocked or enclosed, temperatures can rise quickly and may lead to a fire.

## Starting the Generator

1. Make sure the generator is on a solid, flat, level surface.
2. Disconnect all electrical loads from the generator. Never start or stop the generator with electrical loads connected.
3. Turn the Fuel Switch to the desired fuel source. When the Fuel Switch is in the Gasoline position, the generator is ready to start with Gasoline. When the Fuel Switch is in the Propane position, the generator is ready to start with propane. When the Fuel Switch is in the Natural Gas position, the generator is ready to start with Natural Gas.

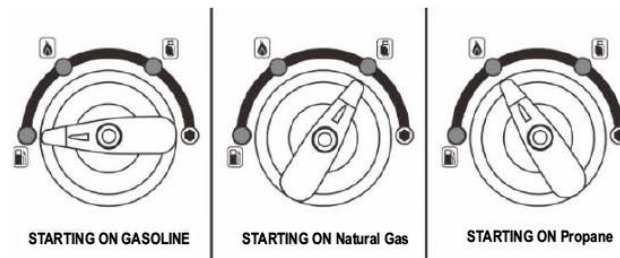

4. Main Switch ON  
Press the Main Switch to the ON position to enable the START Button.

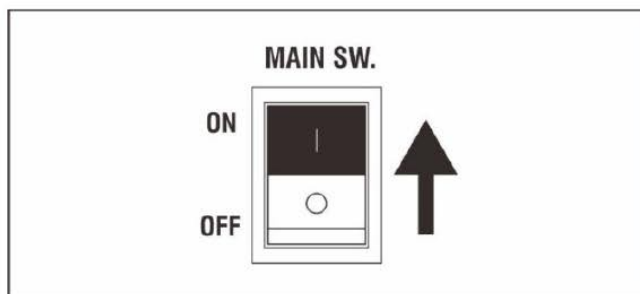

5. Choose the starting method  
Recoil Start: Firmly grasp and pull the recoil handle slowly until you feel resistance, let it retract then pull it swiftly and fully.

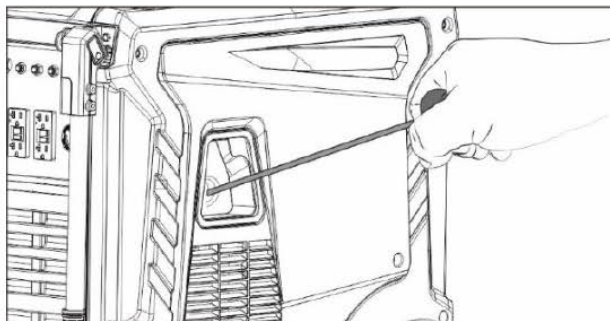

# Operation

**One-Push Start:** Press and hold the start button for 0.5-5 seconds, then release to start the generator.

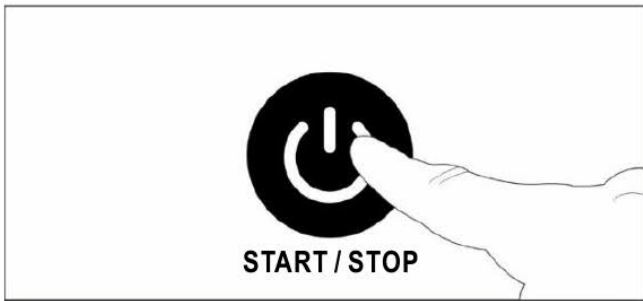

**Remote Start:** Press the START button on the remote FOB for 1 second, then release, to start the generator.

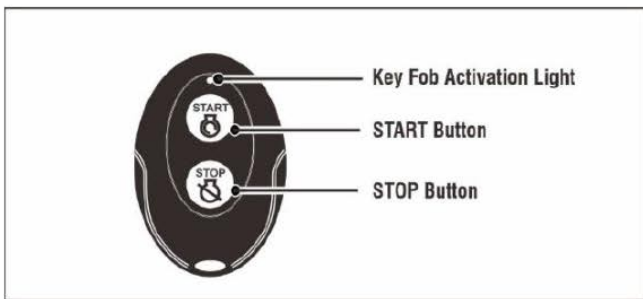

**NOTE:** If the generator does not successfully start using the one-push start or remote start, the generator battery may need to be charged. Use recoil start to start the generator. The generator battery will be charged during generator operation.

If you store the generator for more than 30 days, it is recommended to attach a floating charger delivering 1 amp or less to the battery overnight to maintain its charge level.

6. Press the Low Idle button to activate Low Idle mode. The green indicator light will illuminate when the mode is enabled.

Use Low Idle mode based on load conditions.

If the generator load exceeds 50%, it is recommended to turn off Low Idle for optimal performance.

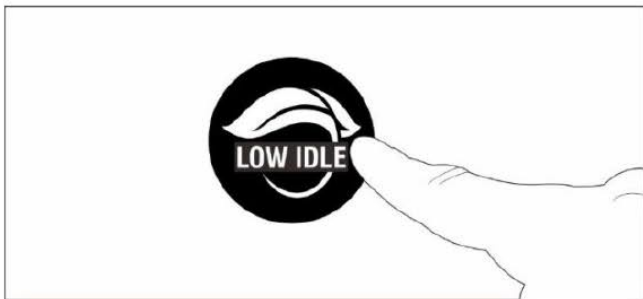

7. Place the Circuit Breaker Switch in the "ON" position.

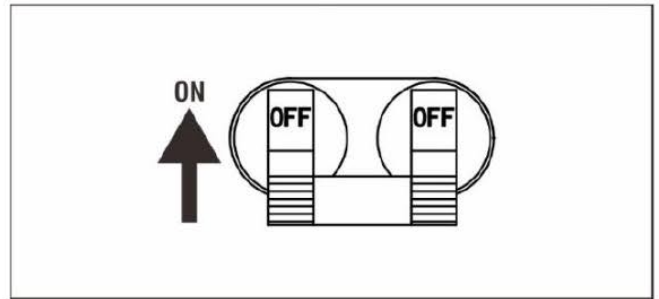

8. Plug in devices.

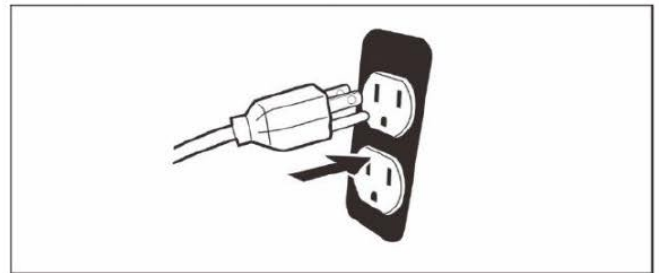

## **! DANGER**

Fire and explosion hazard. Always turn the propane tank valve to the fully closed position when not running the generator on propane.

## **! WARNING**

When using the generator with propane, make sure there is no possible ignition source close to the generator.

## **SPECIAL NOTE**

To prevent battery drain, your Pulsar model PGD125TiSCO remote control feature will enter 'sleep mode' after 168 hours of inactivity. To reset the remote feature, simply cycle the power switch off and then on again.

## **Gasoline to LPG or NG**

**IMPORTANT:** Load capacity is reduced when running on LPG/NG. Ensure the generator can supply enough (running) and surge (starting) watts for the items you are powering before switching to LPG or NG.

1. Turn the LPG tank valve (natural gas supply line valve) to the fully open position.
2. Turn the fuel selector switch to LPG or NG operation.

## LPG or NG to Gasoline

1. Turn the fuel selector switch to gasoline operation.
2. Turn the LPG tank valve (natural gas supply line valve) to the fully closed position.

**NOTE:** When switching to LPG or NG operation the engine may run rough for a few seconds while it purges gasoline from the carburetor.

If the engine stops when switching fuel sources, disconnect all loads then restart the engine on the fuel source of choice.

## Parallel Operation

The parallel connection ports allow you to connect two generators to increase the total available electrical power. Follow the instructions included with your parallel connection kit for proper installation and operation.

## Overload Indicator

**Note:** The OVERLOAD light may turn on for a few seconds as a large device starts. This is normal for loads approaching the capacity of this generator.

1. The total combined load through the outlets on the generator must not exceed the running power of the generator.

2. If the OVERLOAD light turns on and the generator stops producing power, it has been overloaded.

3. Turn off and disconnect all electrical devices and stop the engine. Compare device requirements to generator rating and reduce the total wattage of connected devices if necessary. Move anything that may be limiting generator ventilation away.

4. Check if any circuit breakers have tripped and make sure that ALL circuit breakers are reset before starting the generator again.

5. Restart the engine and reconnect devices while being careful to not overload the generator.

6. Any generator will produce less power at high altitudes and/or in hot weather. Please contact Pulsar Support at 866.591.8921 for details.

## Low Oil Indicator

1. If the engine oil level is too low, the LOW OIL light turns on and the engine will automatically shut off.
2. The engine cannot be restarted until the proper amount of oil has been added. Add the appropriate type of oil until the oil level is at the proper level. SAE 10w-30 oil is recommended for general use.

### NOTICE

Do not run the engine with too little oil. The engine will shut off if the engine oil level is too low.

## Voltage Selector

The Voltage Selector allows more current to be available at 120V outlets if 240V output is not required:

- Switch to 120V only: 120V sockets and 120V/2400V dual voltage sockets can be used, but 120V/240V dual voltage sockets can only output 120V.
- Switch to 120V/240V: Both 120V and 240V outlets can be used.

**NOTE:** Do not change the switch while under load. For parallel function, switch position must be at 120/240V.

## Stop The Engine

1. Turn off the LPG tank valve (or natural gas supply line) Never start or stop the generator with electrical devices plugged in.

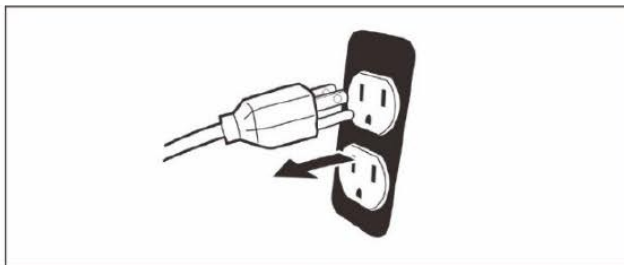

2. Select a Stopping Method

### a. One-Push Stop

Press the START/STOP button on the generator control panel 0.5-5 seconds to shut down the generator.



### b. Remote Stop

Press and hold the STOP button on the remote key fob for 1 second, then release to stop the generator.

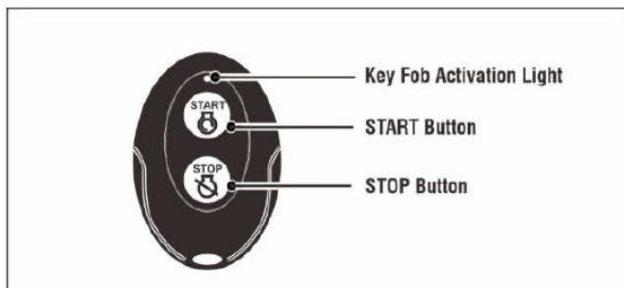

### 3. Main Switch down to OFF position.

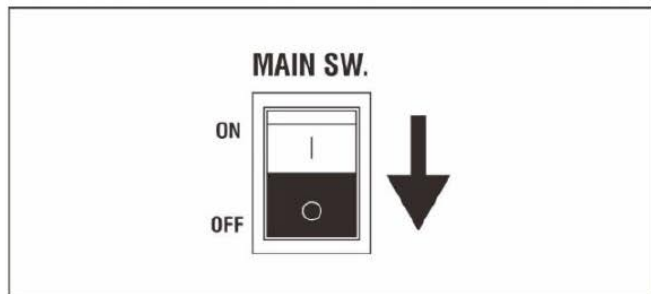

### 4. Turn the fuel selector knob to the off position.



## Generator Capacity

### NOTICE

Do not overload the generator's capacity. Exceeding your generator's wattage capacity can damage the generator and/or electrical devices connected to it.

Ensure the generator can supply enough continuous (running) and surge (starting) watts for the items you will power at once.

The total power requirements (Volts x Amps = Watts) of all appliances connected must be considered. Appliance and power tool manufacturers usually list rating information near the model or serial number. To determine power requirements:

1. Select the items you will power at the same time.
2. Total the continuous (running) watts of these items. This is the amount of power the generator must produce to keep the items running. See the wattage reference chart on the next page.
3. Estimate how much surge (starting) watts you will need. Surge wattage is the short burst of power necessary to start electric motor-driven tools or appliances such as a circular saw or refrigerator. Not all motors start at the same time, total surge watts can be estimated by adding only the item(s) with the highest additional surge watts to the total rated watts from step 2.

Example:

Tool or Appliance	Running Watts*	Starting Watts*
RV Air Conditioner (13,000 BTU)	1100	1100
TV (Flat Screen)	150	150
RV Refrigerator	180	180
Radio	50	50
Light (75 Watts)	75	75
Coffee Maker	600	600
	2155 Total	3275
	Running Watts*	Highest Starting Watts*

\*Wattages listed are approximate. Verify actual wattage.

## ⚠ WARNING

**ACCIDENTAL STARTING:** Turn the fuel selector to the "OFF" position, wait for the engine to cool, and disconnect the spark plug cable before performing any inspection, maintenance, or cleaning procedures.

**EQUIPMENT FAILURE:** Do not use damaged equipment. If abnormal noise, vibration, or excess smoking occurs, correct the problem before further use.

Many maintenance procedures, including any not detailed in this manual, will need to be performed by a qualified technician for safety. If you have any doubts about your ability to safely service the equipment or engine, have a qualified technician service the equipment instead.

### Cleaning, Maintenance, and Lubrication Schedule

**Note:** This maintenance schedule is intended solely as a general guide. If performance decreases or if equipment operates unusually, check systems immediately. The maintenance needs of each generator will differ depending on factors such as duty cycle, temperature, air quality, fuel quality, and other factors.

**Note:** The following procedures are in addition to the regular checks and maintenance explained as part of the regular operation of the engine and equipment.

Procedure	Before Each Use	Monthly or every 8 hr. of use	Every 3 mo. or 50 hr. of use	Every 6 mo. or 100 hr. of use	Yearly or every 300 hr. of use	Every 2 Years
1. Brush off outside of engine 2. Check engine oil level 3. Check air filter	√					
Change engine oil				√		
Clean/replace air cleaner			√			
1. Check and clean spark plug 2. Check and clean spark arrestor				√		
1. Check/adjust idle speed 2. Check/adjust valve clearance 3. Clean fuel tank, strainer and carburetor 4. Clean carbon build-up from combustion chamber					√	
Replace fuel line if necessary						√

## Checking and Filling Gasoline

### ⚠ WARNING

**TO PREVENT SERIOUS INJURY FROM FIRE:**  
Fill the fuel tank in a well-ventilated area away from ignition sources. If the engine is hot from use, shut the engine off and wait for it to cool before adding fuel. Do not smoke.

1. Clean the Fuel Cap and the area around it.
2. Unscrew and remove the Fuel Cap.
3. Remove the strainer and remove any dirt and debris. Then replace the strainer.

**Note:** Do not use gasoline containing more than 10% ethanol (E10). Do not use E85 ethanol. Add a fuel stabilizer to the gasoline or the Warranty is VOID.

**Note:** Do not use gasoline that has been stored in a metal fuel container or a dirty fuel container. It can cause particles to enter the carburetor, affecting engine performance and/or causing damage.

4. If needed, fill the Fuel Tank to about 1 inch under the fill neck with 87 octane unleaded gasoline that has been treated with a fuel stabilizer additive. Follow fuel stabilizer manufacturer's recommendations for use.
5. Replace the Fuel Cap.
6. Wipe up any spilled gasoline and allow excess to evaporate before starting the engine. To prevent FIRE, do not start the engine while the smell of fuel hangs in the air.

## Engine Oil Change

### ⚠ CAUTION

Oil is very hot during operation and can cause burns. Wait for the engine to cool before changing the oil.

1. Make sure the engine is stopped and is level.
2. On the right side of the generator, loose the screws and remove the Side Panel.

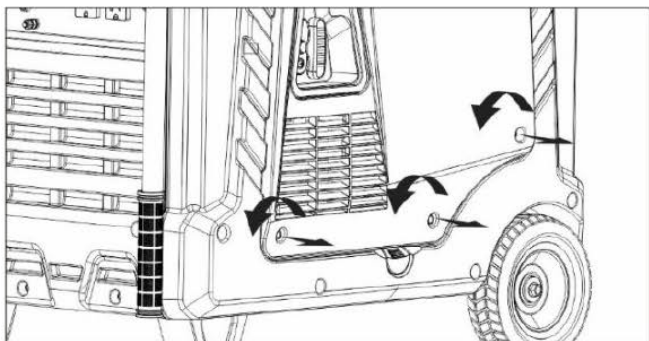

3. Remove the lower Rubber Seal from underneath the generator.

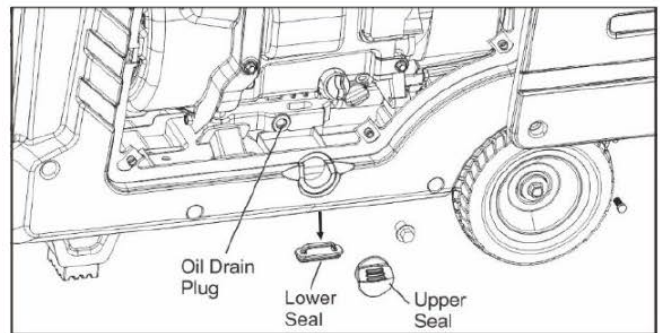

4. Place an oil drain pan under the generator and center it under the Oil Drain Hose opening.
5. Remove the upper Rubber Seal from below the Oil Drain Plug.
6. Use a wrench to remove the Oil Drain Bolt and allow the oil to drain completely.
7. Replace the Oil Drain Bolt. Put the Oil Drain Hose back into the generator.
8. Remove the Cap/Dipstick, turning it counterclockwise.
9. Add the appropriate type of oil until the oil level is at the proper level. SAE 10w-30 oil is recommended for general use.  
**Note:** Ensure the generator is level when adding oil to prevent overfilling which could cause engine damage.
10. Check the oil level. The oil level should be just below the hole edge as shown.

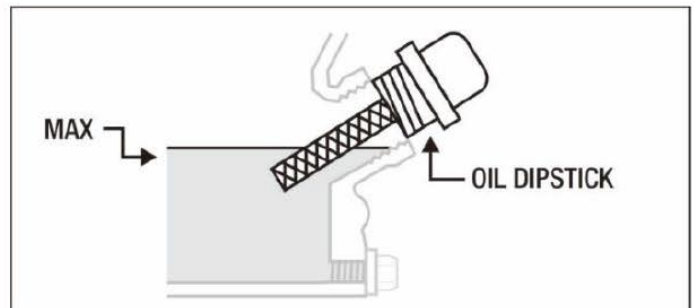

11. Thread the Oil Fill Cap/Dipstick back in clockwise and replace the Side Panel.

## Air Filter Element

1. Loosen screws and remove the Air Filter Side Panel on the left side of the generator.

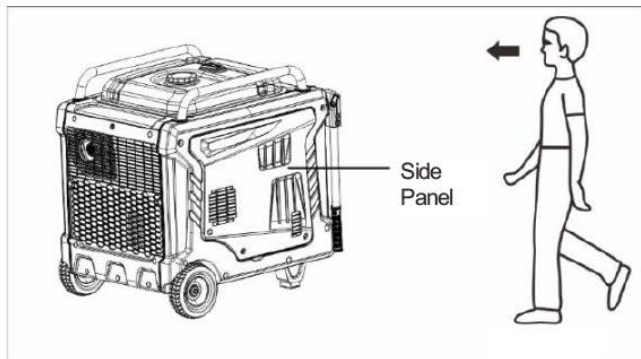

2. Unsnap the Air Filter Cover Clip and remove the Air Filter Cover. See the figure below.
3. Remove the Air Filter.

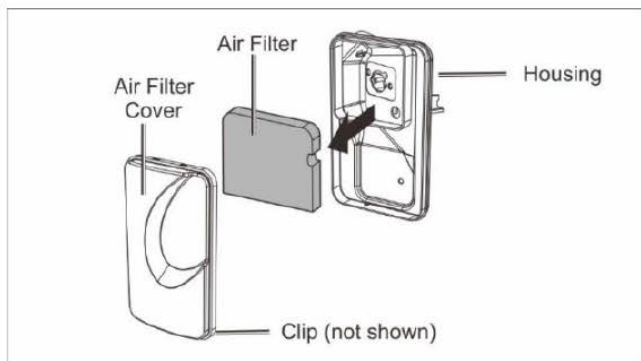

## Spark Arrestor Maintenance

### ⚠ WARNING

**TO PREVENT SERIOUS INJURY AND FIRE:**  
Operate only with proper spark arrestor installed

### ⚠ WARNING

The operation of this equipment may create sparks that can start fires around dry vegetation. A spark arrestor may be required. The operator should contact local fire agencies for laws or regulations relating to fire prevention requirements.

1. Allow the generator to cool completely.
2. Remove the Screws from the back of the generator.
3. Remove the Tail Pipe and Spark Arrestor.
4. Clean the Spark Arrestor using a wire brush. Replace the arrestor if damaged.

### ⚠ WARNING

**TO PREVENT SERIOUS INJURY FROM ACCIDENTAL BRUSH FIRE,** secure the Spark Arrestor back in place immediately after cleaning and before further operation.

## Spark Plug Maintenance

1. Loosen two screws and remove the Side Panel on the left of the generator.

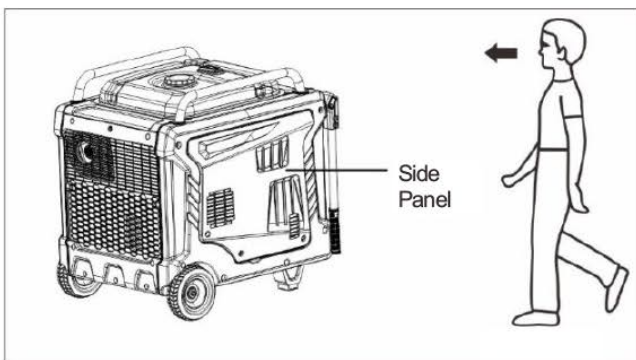

2. Disconnect the Spark Plug Cap. Blow or vacuum debris from around the Spark Plug.

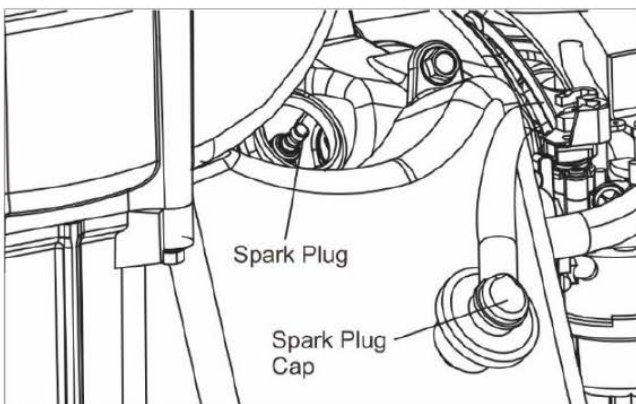

3. Using the Spark Plug Wrench, remove the Spark Plug.
4. Inspect the Spark Plug: If the electrode is oily, clean it using a clean, dry rag. If the electrode has deposits on it, clean it with a brass wire brush. If the white insulator is cracked or chipped, replace the spark plug.

## NOTICE

Use only BPR6ES (NGK) spark plugs or equivalent. Using the wrong type may damage the engine.

1. When installing a new spark plug, adjust the gap according to the Specifications Chart.
  - Do not strike the center electrode.
2. Apply a small amount of anti-seize compound to the threads.
  - Hand-tighten until the gasket touches the cylinder head, then tighten with the wrench an additional 3/4 turn.
3. Apply a thin coat of silicone dielectric grease (not included) inside the spark plug boot.
4. Reinstall the Spark Plug Access Cover and Access Panel.

## NOTICE

A loose spark plug may cause overheating. Over-tightening can damage the cylinder head threads.

## Draining the Carburetor

After closing the fuel valve, place a proper container under the carburetor. Locate the clear plastic drain tube and the nearby 8 mm drain screw. Insert the drain tube into a gasoline-safe container. Loosen the drain screw to let gasoline flow out. After fuel is fully drained, retighten the drain screw.

Note: Discard aged or untreated fuel in accordance with local environmental regulations. Never use stale gasoline.

## WARNING

To prevent injury or fire, close the fuel valve before draining the carburetor.

## Lubrication Before Storage

Lubrication Before Storage

1. Change the engine oil.
2. Clean the spark plug area.
  - Remove the spark plug and pour 1 tablespoon of engine oil into the cylinder.
3. Replace the spark plug but leave the cap disconnected.
4. Pull the recoil starter slowly 2–3 times to distribute oil.
  - Stop when resistance increases—this is the compression stroke.

## Storage Instructions

If the generator will not be used for more than 30 days, follow the steps below:

1. Cleaning  
Let the engine cool, then wipe down with a dry cloth.

## NOTICE

Do not wash the generator with water. Moisture may damage internal components.

2. Fuel System – Gasoline Treatment
  - Fill the tank with fresh gasoline + stabilizer.
  - Follow fuel stabilizer manufacturer's instructions.

## WARNING

Fill fuel in a well-ventilated area away from ignition sources. If recently used, allow the engine to cool completely.

3. Long-Term Lubrication Follow the 4-part lubrication steps listed above (change oil, oil the cylinder, etc.).
4. Storage Area Store in a dry, well-ventilated location away from children, heaters, dryers, or other ignition sources.

## NOTICE

During storage, run the engine every 3 months for 15–20 minutes to maintain battery and fuel system health.

5. After Storage
  - Drain fuel if storage exceeds 90 days.
  - Replace with fresh gasoline before starting.
  - Treated fuel may also degrade over time—replace if engine fails to start.

# Specifications

Item	Specification
Product Description	12500W Tri-Fuel Inverter Generator
Engine Type	Single-cylinder, 4-stroke, air-cooled, OHV
Displacement	458 cc
Valve Configuration	OHV (Overhead Valve)
Cooling System	Forced air cooling
Start Type	Recoil Start / Electric Start (One-Push Start) / Remote Start
Fuel Tank Capacity	6.9 US gallons (26 L)
Fuel Type	Gasoline, Propane (LPG), Natural Gas (NG)
Engine Oil Capacity	1.1 L (37 fl.oz)
Engine Oil Type	SAE 10W-30, API classification SE or higher
Noise Level (7m at 50% load)	66 dB
Rated Power	10,000 W (GAS) / 9,000 W (LPG) / 8,000 W (NG)
Peak Power	12,500 W (GAS) / 11,250 W (LPG) / 10,000 W (NG)
Rated Voltage	120/240V
Amperage (120V Rated/Peak)	83.3/104.2A (GAS) 75.0/93.8A (LPG) 66.7/83.3A (NG)
Amperage (240V Rated/Peak)	41.7/52.1A (GAS) 37.5/46.9A (LPG) 33.3/41.7A (NG)
Rated Frequency	60Hz
Power Factor	1.0
Phase	Single-phase
DC Output	USB 5V/3A
Generator Type	Permanent magnet alternator
Inverter Control	Controller-regulated
Dimensions (L×W×H)	31.4"×22.8"×29.4" (785×575×745 mm)
Net Weight	247 lbs (112 kg)
Warranty	3 Years

Problem	Possible Causes	Probable Solutions
<p align="center"><b>THE ENGINE WILL NOT START</b></p>	<p><b>FUEL RELATED:</b></p> <ol style="list-style-type: none"> <li>1. No fuel in the tank or fuel valve closed.</li> <li>2. Gasoline with more than 10% ethanol used. (E15, E20, E85, etc.)</li> <li>3. Low-quality or deteriorated old gasoline.</li> <li>4. Carburetor not primed.</li> <li>5. Dirty fuel passageways.</li> <li>6. Carburetor needle stuck. Fuel can be smelled in the air.</li> <li>7. Too much fuel in the float bowl. This can be caused by the carburetor needle sticking.</li> <li>8. Clogged Fuel Filter.</li> </ol>	<p><b>FUEL RELATED:</b></p> <ol style="list-style-type: none"> <li>1. Fill the fuel tank with fresh 87-octane stabilizer-treated unleaded gasoline and open the fuel valve. Do not use gasoline with more than 10% ethanol (E15, E20, E85, etc.).</li> <li>2. Clean out ethanol-rich gasoline from the fuel system. Replace components damaged by ethanol. Use fresh 87+ octane stabilizer-treated unleaded gasoline only. Do not use gasoline with more than 10% ethanol (E15, E20, E85, etc.).</li> <li>3. Use fresh 87-octane stabilizer-treated unleaded gasoline. Do not use gasoline with more than 10% ethanol (E15, E20, E85, etc.).</li> <li>4. Pull on Starter Handle to prime.</li> <li>5. Clean out passageways using a fuel additive. Heavy deposits may require further cleaning</li> <li>6. Gently tap the side of the carburetor float chamber with a screwdriver handle.</li> <li>7. Shut off the fuel valve, move the generator to a safe, outdoor location, and contact a certified Pulsar Service Center before using the generator again.</li> <li>8. Replace Fuel Filter.</li> </ol>
	<p><b>IGNITION (SPARK) RELATED:</b></p> <ol style="list-style-type: none"> <li>1. Power Switch at OFF position.</li> <li>2. Spark plug cap not connected securely.</li> <li>3. Spark plug electrode wet or dirty.</li> <li>4. Incorrect spark plug gap.</li> <li>5. The spark plug cap is broken.</li> <li>6. Circuit breaker tripped (electric start models only).</li> <li>7. Incorrect spark timing or faulty ignition system.</li> </ol>	<p><b>IGNITION(SPARK)RELATED</b></p> <ol style="list-style-type: none"> <li>1. Turn the Power Switch to ON.</li> <li>2. Connect the spark plug cap properly.</li> <li>3. Clean spark plug.</li> <li>4. Correct spark plug gap.</li> <li>5. Replace the spark plug cap</li> <li>6. Reset the circuit breaker. Check the wiring and starter motor if the breaker continues to trip.</li> <li>7. Have a qualified technician diagnose/ repair the ignition system.</li> </ol>



Problem	Possible Causes	Probable Solutions
<p align="center"><b>THE ENGINE WILL NOT START</b></p>	<p><b>COMPRESSION RELATED:</b></p> <ol style="list-style-type: none"> <li>1. Cylinder not lubricated. Problem after long storage periods.</li> <li>2. Loose or broken spark plug. (A hissing noise will occur when trying to start.)</li> <li>3. Loose cylinder head or damaged head gasket. (A hissing noise will occur when trying to start.)</li> <li>4. Engine valves or tappets are misadjusted or stuck.</li> </ol>	<p><b>COMPRESSION RELATED:</b></p> <ol style="list-style-type: none"> <li>1. Pour a tablespoon of oil into the spark plug hole. Crank the engine a few times and try to start again.</li> <li>2. Tighten spark plug. If that does not work, replace the spark plug. If the problem persists, there might be a head gasket issue.</li> <li>3. Have a qualified technician service the cylinder head.</li> <li>4. Have a qualified technician adjust/repair valves and tappets.</li> </ol>
	<p><b>ENGINE OIL RELATED:</b></p> <ol style="list-style-type: none"> <li>1. Low engine oil.</li> <li>2. The generator may be on a slope, triggering a low oil shutdown.</li> </ol>	<p><b>ENGINE OIL RELATED:</b></p> <ol style="list-style-type: none"> <li>1. Fill engine oil to the proper level. Check engine oil before EVERY use.</li> <li>2. Operate the engine on a level surface. Check engine oil level.</li> </ol>
	<p><b>SPARK ARRESTOR RELATED:</b></p> <ol style="list-style-type: none"> <li>1. Spark Arrestor clogged with soot.</li> </ol>	<p><b>SPARK ARRESTOR RELATED:</b></p> <ol style="list-style-type: none"> <li>1. Clean and replace the Spark Arrestor.</li> </ol>
<p align="center"><b>ENGINE MISFIRES</b></p>	<ol style="list-style-type: none"> <li>1. The spark plug cap is loose.</li> <li>2. Incorrect spark plug gap or damaged spark plug.</li> <li>3. Defective spark plug cap.</li> <li>4. Old or low-quality gasoline.</li> <li>5. Incorrect compression.</li> </ol>	<ol style="list-style-type: none"> <li>1. Check cap and wire connections.</li> <li>2. Re-gap or replace the spark plug.</li> <li>3. Replace the spark plug cap.</li> <li>4. Use only fresh 87 octane stabilizer-treated unleaded gasoline. Do not use gasoline with more than 10% ethanol (E15, E20, E85, etc.).</li> <li>5. Diagnose and repair compression. (Use Engine will not start: COMPRESSION RELATED section.)</li> </ol>
<p align="center"><b>ENGINE STOPS SUDDENLY</b></p>	<ol style="list-style-type: none"> <li>1. Low oil shutdown.</li> </ol>	<ol style="list-style-type: none"> <li>1. Fill engine oil to the proper level. Check engine oil before EVERY use.</li> </ol>



Problem	Possible Causes	Probable Solutions
<b>ENGINE STOPS SUDDENLY</b>	<ol style="list-style-type: none"> <li>1. Fuel tank empty or full of impure or low-quality gasoline.</li> <li>2. A defective fuel tank cap creates a vacuum and prevents proper fuel flow.</li> <li>3. Faulty magneto.</li> <li>4. Disconnected or improperly connected spark plug cap.</li> </ol>	<ol style="list-style-type: none"> <li>1. Fill the fuel tank with fresh 87-octane stabilizer-treated unleaded gasoline. Do not use gasoline with more than 10% ethanol (E15, E20, E85, etc.).</li> <li>2. Test/replace the fuel tank cap.</li> <li>3. Have a qualified technician service the magneto.</li> <li>4. Secure the spark plug cap.</li> </ol>
<b>ENGINE STOPS WHEN UNDER HEAVY LOAD</b>	<ol style="list-style-type: none"> <li>1. Dirty air filter</li> <li>2. Engine running cold.</li> </ol>	<ol style="list-style-type: none"> <li>1. Clean element.</li> <li>2. Allow the engine to warm up before operating equipment.</li> </ol>
<b>ENGINE KNOCKS</b>	<ol style="list-style-type: none"> <li>1. Old or low-quality gasoline.</li> <li>2. Generator overloaded.</li> <li>3. Incorrect spark timing, deposit buildup, worn engine, or other mechanical problems.</li> </ol>	<ol style="list-style-type: none"> <li>1. Fill the fuel tank with fresh 87-octane stabilizer-treated unleaded gasoline. Do not use gasoline with more than 10% ethanol (E15 E20, E85, etc.).</li> <li>2. Do not exceed the generator's load rating.</li> <li>3. Have a qualified technician diagnose and service the engine.</li> </ol>
<b>ENGINE BACKFIRES</b>	<ol style="list-style-type: none"> <li>1. Impure or low-quality gasoline.</li> <li>2. Engine too cold.</li> <li>3. Intake valve stuck or an overheated engine.</li> <li>4. Incorrect timing.</li> </ol>	<ol style="list-style-type: none"> <li>1. Fill fuel tank with fresh 87+ octane stabilizer treated unleaded gasoline Do not use gasoline with more than 10% ethanol (E15, E20, E85, etc.)</li> <li>2. Use cold weather fuel and oil additives to prevent backfiring.</li> <li>3. Have a qualified technician diagnose and service the engine.</li> <li>4. Check engine timing.</li> </ol>
<b>THE ATTACHED DEVICE DOESNT HAVE POWER</b>	<ol style="list-style-type: none"> <li>1. Device not plugged in properly</li> <li>2. Circuit Breaker tripped.</li> <li>3. Generator needs service.</li> </ol>	<ol style="list-style-type: none"> <li>1. Turn off and unplug the device, then plug it back in again and turn it on.</li> <li>2. Turn off and unplug the device, reset the Circuit Breaker, plug in the device and turn on.</li> <li>3. Have the authorized service center repair the generator.</li> </ol>



Follow all safety precautions whenever diagnosing or servicing the generator or engine.

## 120/240V, 60Hz Electrical

