



Assembly and Operating Instructions

1600 SERIES

BUILT IN

BBG1640SA, BBG1640DA
BBG1650SA, BBG1650DA

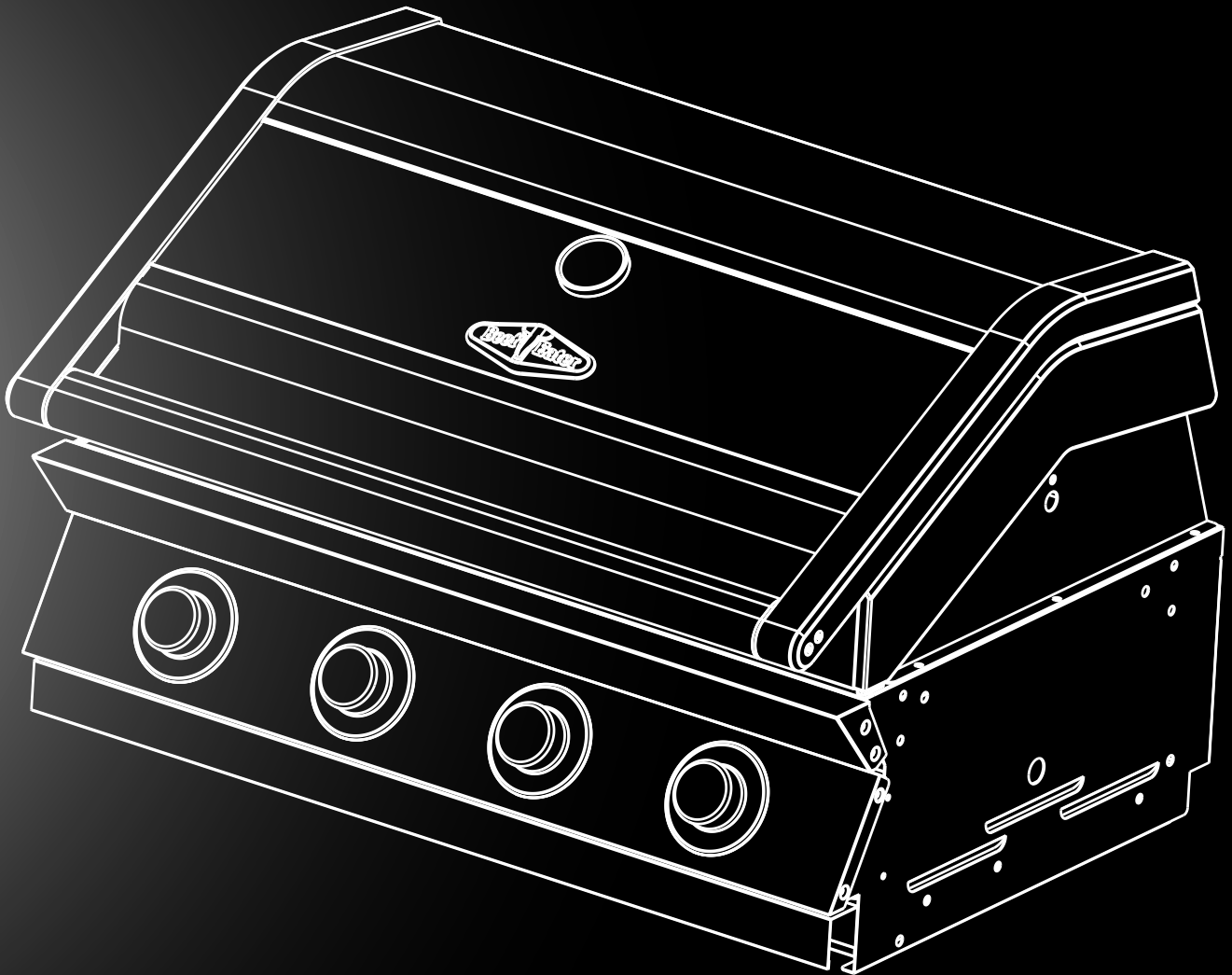

FOR OUTDOOR USE ONLY

AUSTRALIA / NEW ZEALAND



Dear Customer,

Congratulations and thank you for choosing our barbecue. We are sure you will find it a pleasure to use. Before you use the barbecue, we recommend that you read through the relevant sections of this manual, as well as the built-in manual to get a full understanding of your appliance and its functions.

To avoid the risks that are always present when you use an appliance, it is important that the appliance is installed correctly and that you read the safety instructions carefully to avoid misuse and hazards.

We recommend that you keep both instruction booklets for future reference and pass it on to any future owners.

After unpacking the appliance, please check it is not damaged. If in doubt, do not use the appliance but contact your local customer care centre.

This appliance complies with requirements of Australian Standards AS5263.

Conditions of use

These important notes apply to your appliance, failure to adhere to these conditions of use may affect your ability to make a claim under the manufacture's warranty.

- This appliance must be serviced only by a qualified licenced person.
- This product is intended for personal, domestic or household use only, not commercial use.
- This product is intended for outdoor use only.
- This product must be installed, operated and maintained as per the instructions.

Please ensure you read both instruction manuals fully before you call for service, or a full service fee could be applicable.

Record model and serial number here:

Model number:

Serial number:.....

PNC:.....

Important safety instructions.....	3
Product description.....	4
Product dimensions.....	5
Gas specifications.....	6
Natural gas conversion.....	7
Installation warnings.....	8
Mounting enclosure guideline.....	9
Assembling the barbecue.....	10
Burner removal and fitting and leak test procedure.....	18
Operating instructions.....	19
Cooking methods.....	20
Cleaning and care.....	22
Troubleshooting.....	23
Gas consumption.....	24
Gas specifications.....	25
Warranty.....	27

Please read the user manual carefully and store in a handy place for later reference.

The symbols you will see in this booklet have these meanings:



WARNING

This symbol indicates information concerning your personal safety.



CAUTION

This symbol indicates information on how to avoid damaging the appliance.



IMPORTANT

This symbol indicates tips and information about use of the appliance.



ENVIRONMENT

This symbol indicates tips and information about economical and ecological use of the appliance.

IMPORTANT INFORMATION THAT MAY IMPACT YOUR MANUFACTURER'S WARRANTY

Adherence to the directions for use in this manual is extremely important for health and safety. Failure to strictly adhere to the requirements in this manual may result in personal injury, property damage and affect your ability to make a claim under the BeefEater manufacturer's warranty provided with your product. Products must be used, installed and operated in accordance with this manual. You may not be able to claim on the BeefEater manufacturer's warranty in the event that your product fault is due to failure to adhere this manual.

Please read the user manuals carefully and store in a handy place for later reference.



IMPORTANT

Important – check for any damages or marks

If you find the barbecue is damaged or marked, you must report it within 7 days if you wish to claim for damage/marks under the manufacturer's warranty. This does not affect your statutory rights.



ENVIRONMENT

Information on disposal for users

- Most of the packing materials are recyclable. Please dispose of those materials through your local recycling depot or by placing them in appropriate collection containers.
- If you wish to discard this product, please contact your local authorities and ask for the correct method of disposal.



WARNING

This appliance must be serviced only by a qualified licensed person.

Improper installation, adjustment, alteration or maintenance can cause injury or property damage and may affect your ability to claim under the manufacturer's warranty.

Please contact your nearest BeefEater Service Department for additional information or assistance for an approved installer.

Note to the installer

- After the barbecue is removed from the packaging take care to protect the gas hose connection from damage.
- Wear gloves when assembling the barbecue to protect your hands from cuts
- This manual must remain with the owner for future reference.



WARNING

- Do not lean over barbecue when lighting.
- Do not leave the barbecue unattended when alight.
- Do not delay lighting once the gas has been turned on.
- Do not store or use aerosol cans in the vicinity of the barbecue.
- Do not store or use flammable liquids or flammable materials in the vicinity of this barbecue.
- Do not use caustic or abrasive based cleaners on the barbecue.
- Do not attempt to dismantle or adjust the control valves.
- Do not attempt to dismantle or adjust the regulator.

- Do not test for leaks with a naked flame.
- Do not modify the construction of this appliance or modify the injector orifice size.
- Do not place articles on or against this appliance
- Do not obstruct any ventilation of the barbecue.
- Do not allow children to operate or play near the barbecue.

Failure to adhere to the above warnings may cause injury or property damage and affect your ability to make a claim under the manufacturer's warranty.



CAUTION

This appliance is set up for LPG gas and is labelled accordingly. A natural gas conversion kit is available as an accessory if required. Conversion of this unit to natural gas must be carried out by a qualified licensed person and a Certificate of Compliance must be issued to the owner at the completion of the installation and conversion.



IMPORTANT

BeefEater Barbecues are approved for OUTDOOR USE ONLY and must not be used in a building, garage or any other enclosed area.

- BeefEater Barbecues must not be used inside recreational vehicles or boats.
- Read instructions thoroughly before operating this Barbecue.
- Save this manual for future reference.
- Always use the Barbecue on a flat, level surface.
- Some foods produce flammable fats and juices. Regular cleaning is essential.
- Attend an operating barbecue at all times. Damage caused by fat & grease fires is not covered by warranty.
- When not in use keep Barbecue dry and covered.



WARNING

If you smell gas:

1. Shut off gas to the appliance.
2. Extinguish any open flame.
3. Open hood.
4. If odour continues, immediately call your gas supplier or your fire department.

For your safety

1. Do not store or use gasoline or other flammable vapours or liquids in the vicinity of this or any other appliance.
2. An LPG cylinder not connected for use shall not be stored in the vicinity of this or any other appliance.

PRODUCT DESCRIPTION

- ① Warming rack
- ② Cast iron grill
- ③ Cast iron hotplate
- ④ Vaporisers
- ⑤ Burners
- ⑥ Roasting hood
- ⑦ Thermometer
- ⑧ Burner box (4 burner barbecue BBG1640 shown)
- ⑨ Control panel
- ⑩ LPG hose and regulator
- ⑪ Grease tray

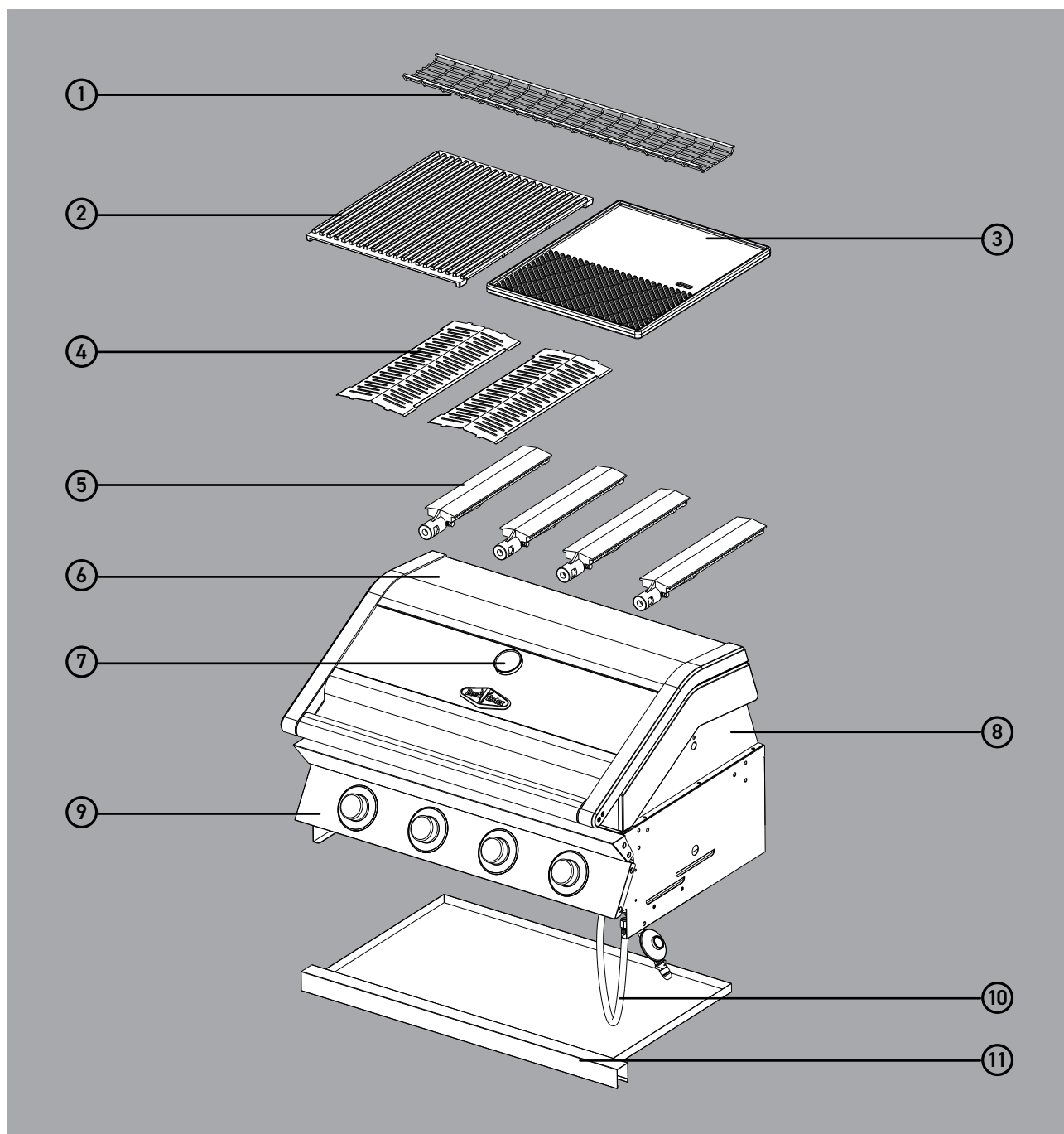

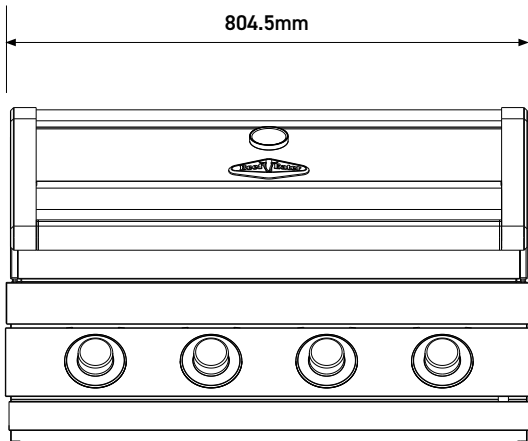

4 burner

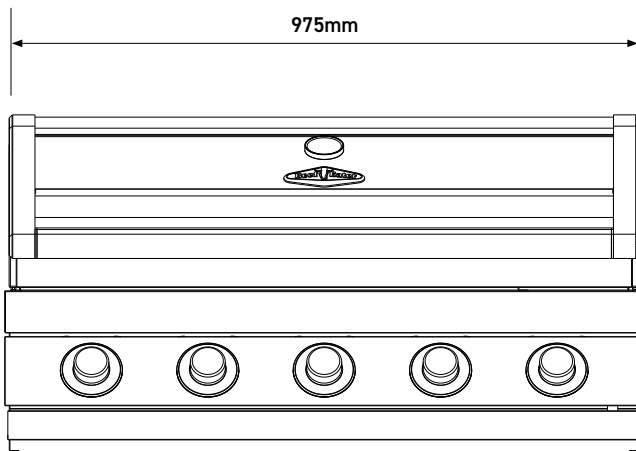
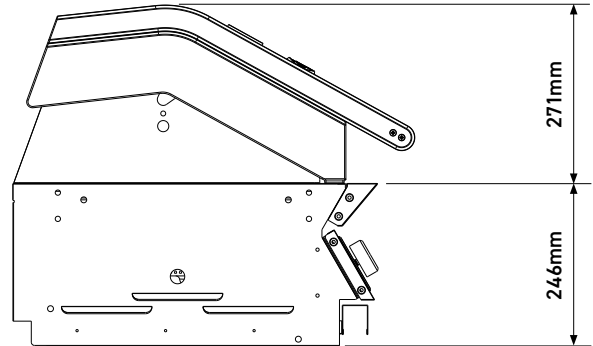

5 burner

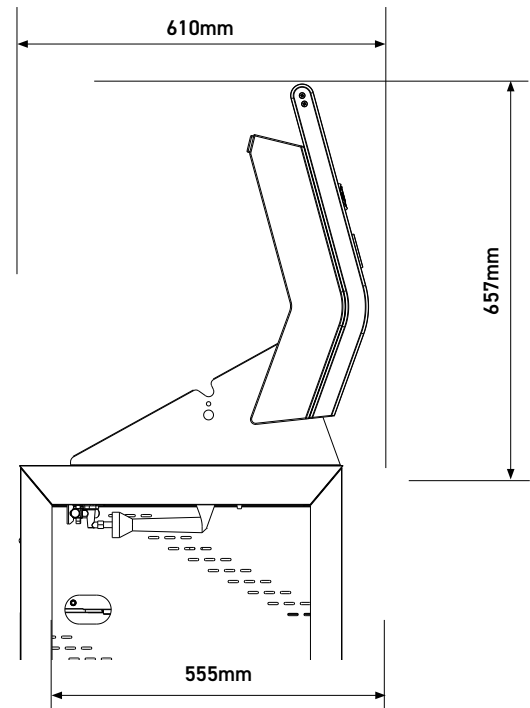

GAS SPECIFICATIONS

MODEL	BBG1640SA	BBG1640DA	BBG1650SA	BBG1650DA
Gas type	Universal LPG	Universal LPG	Universal LPG	Universal LPG
Maximum gas consumption	60 MJ/h	68 MJ/h	75 MJ/h	85 MJ/h
Injector orifice diameter (barbecue burners)	Ø1.10 mm	Ø1.15 mm	Ø1.10 mm	Ø1.15 mm
Number of injectors (barbecue burners)	4	4	5	5
Regulator pressure	2.75 kPa	2.75 kPa	2.75 kPa	2.75 kPa

NOTES:

- This appliance MUST be installed and serviced only by a qualified licensed person.
- This product is intended for outdoor use only.

Connecting the appliance to an LPG gas supply

This barbecue is set up for LPG gas and is labelled accordingly.

The appliance may be supplied LPG from either

- A 9kg portable cylinder, or
- A remote supply via fixed pipe work.

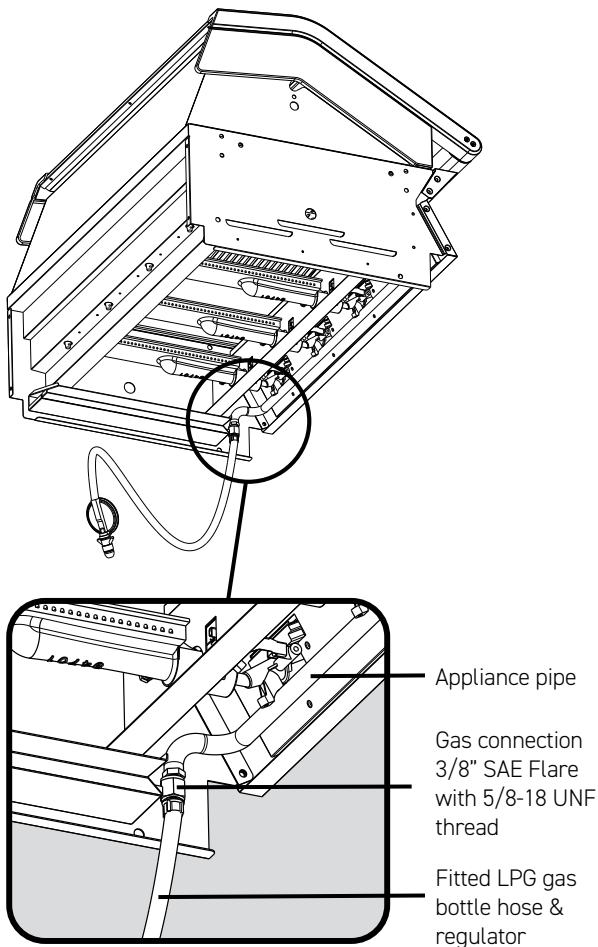

Connecting the appliance to a LPG gas cylinder

- The appliance has a 9kg gas bottle regulator and hose already fitted.
- Connect the POL fitting of the inlet of the regulator to the valve on the LPG cylinder.
- Carry out a leakage check.

Gas bottle safety information

- This appliance, when connected directly to an LPG cylinder, the cylinder capacity shall be 9kg(20lbs).
- The gas cylinder must be made and marked in accordance with specifications for LPG cylinders.
- It is recommended to turn off the cylinder valve when the appliance is not in use.
- Gas cylinders must be stored in an approved housing out of reach of children.
- When disconnecting the gas bottle ensure that all the control valves are in the 'OFF' position.
- Remove the bottle from any housing in which it may be stored before disconnection.
- When reconnecting the hose to the bottle, ensure that all connections are tight before replacing in the storage compartment.
- Carry out a leakage check. (See leak test procedure on page 13).

Connecting to a remote supply of LPG

- The appliance shall be installed in accordance with AS/NZS5601 gas installations and any relevant local gas fitting rules.
- Remove the gas bottle hose from the appliance pipe.
- Connect the consumer supplied fixed LPG pipework and regulator to the appliance pipe.
- Carry out a leakage check on all connections.

WARNING

Conversion of this unit to natural gas must be carried out by a qualified licensed person and a Certificate of Compliance must be issued to the owner on completion of the installation and conversion. Conversion of this barbecue by unlicensed persons may result in improper functioning of the appliance, injury, property damage and may affect your ability to make a claim under the manufacturer's warranty.

Converting the unit to natural gas

This barbecue is set up for LPG gas and is labelled accordingly. A natural gas conversion kit is available (**Part Number BNG1200**) as an accessory if required.

The components in the kit are:

- 6 x brass injectors (natural gas)
- 700mm hose with ½" male pipe thread at one end and 3/8" SAE Flare with 5/8-18 UNF female thread at the other end
- Natural gas regulator with ½" female pipe threads on inlet and outlet
- 1500mm hose with ½" male pipe thread at one end and quick connect at the other end
- 2000mm tether (mobile use only)
- Natural gas sticker

1. Replace 'gas type' sticker

- Locate LPG gas sticker located on the lower face of the control panel and remove it. Put natural gas sticker in its place.

2. Change the injectors

- Remove the burners and grease tray from the appliance to gain access to the injectors.

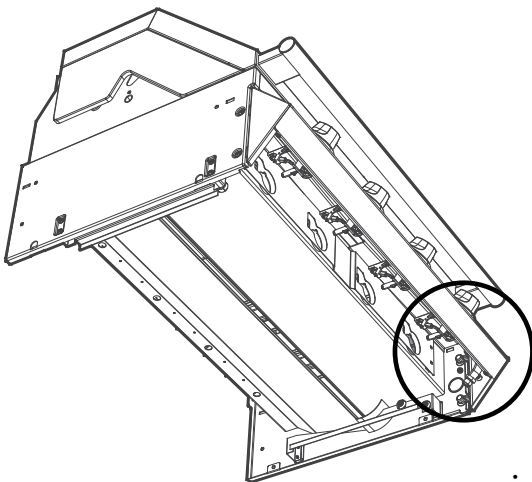

Unscrew the LPG injectors and replace with natural gas injectors on all valves. All injectors are marked with the orifice size.

- Do not overtighten injectors

3. Connecting the appliance to a natural gas supply

- The appliance shall be installed in accordance to AS/NZS5601 gas installations and any relevant local gas fitting rules.
- Remove the fitted LPG gas bottle hose and regulator from the adaptor mounted to the semi-rigid appliance pipe.
- Connect the conversion kit hoses and natural gas regulator. Ensure the flow arrow on the regulator points towards the appliance.
- For Natural Gas check that the supply pressure is at least 1.13 kPa and not more than 5.0 kPa, and adjust if necessary. The operation of the Natural Gas regulator can be confirmed by connecting a manometer to the test point located on the side of the regulator body. With three burners operating at maximum the outlet pressure should measure 1.0 kPa.
- Carry out a leakage check on all connections.

4. Adjust the turndown setting on the valve

NOTE: The final step in the conversion of the barbecue to natural gas is the adjustment of the turndown setting.

- Light each burner and rotate the control knob to the lowest setting, then remove the knob from the valve shaft.
- Using a small flat-blade screwdriver adjust the turndown adjustment screw to achieve a small steady flame on the burner.

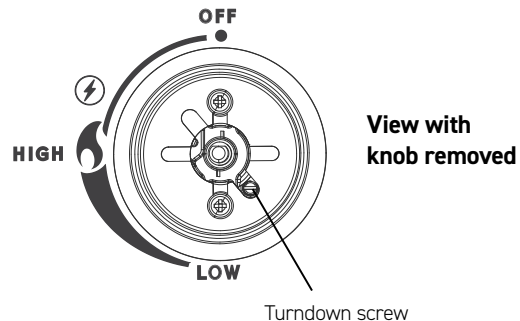

- Replace the knob.
- Recheck the operation of the burner at the maximum and turndown.
- Repeat procedures for all valves.

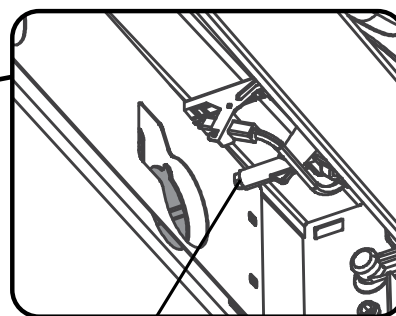

Remove LPG injector and install injector for natural gas.

INSTALLATION WARNINGS



WARNING

- This appliance shall only be used in an above ground, open air situation with natural ventilation without stagnant areas, where gas leakage and products of combustion are rapidly dispersed by wind or natural convection. This barbecue has been designed for outdoor use only. Failure to adhere to these installation instructions may cause injury or property damage and affect your ability to make a claim under the manufacturer's warranty. Refer to diagrams below.
- Never install this barbecue inside any building, garage, shed or breezeway or inside a boat, caravan or recreational vehicle. This is to prevent the possibility of fire or carbon monoxide poisoning or asphyxiation.
- Any enclosure in which this appliance is installed shall comply with one of the following:
 - An enclosure with walls on all sides, but at least one permanent opening at the ground level and no overhead covering
 - Within a partial enclosure that includes an overhead cover and no more than 2 walls
 - Within a partial enclosure that includes an overhead cover and more than 2 walls, the following shall apply:
 - At least 25% of the total wall area is completely open and at least 30% of the remaining wall area is open and unrestricted
- In the case of balconies, at least 20% of the total of the side, back and front wall areas shall be and remain open and unrestricted.

Outdoor area example 1

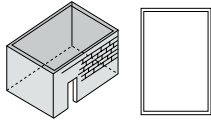

Outdoor area example 2

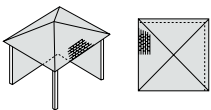

both ends open

Outdoor area example 3

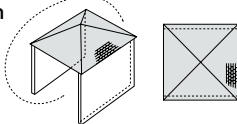

Outdoor area example 4

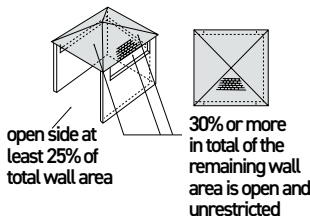

Outdoor area example 5

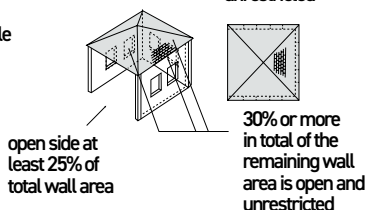

Choosing a location

When planning the location and preparing the installation structure for this appliance note the following:

- This appliance must be installed in accordance with Australian Standard AS 5601 and in accordance with local authority.
- Requirements in these instructions for clearances to combustible materials also apply to combustible materials that have non-combustible materials attached to their surface.
- The minimum clearance from combustible construction materials to all sides of the appliance is 450mm.
- The minimum clearance to a vertical wall above bench level that is made from combustible material is 450mm.
- The vertical clearance above the cooking surface to any combustible materials must be at least 1000mm.
- When using LPG in an enclosure ventilation must be provided. Gas is highly explosive and can cause serious injury and damage to property if allowed to accumulate and then be ignited.
- Avoid windy positions as this will affect cooking performance and burner efficiency. If this situation cannot be avoided some shielding may be necessary.

Natural gas requirements

- The enclosure must be constructed so that access can be gained to the natural gas regulator at all times.

Natural gas conversions



WARNING

Conversion of this unit to natural gas must be carried out by a qualified licensed person and a Certificate of Compliance must be issued to the owner on completion of the installation and conversion. Conversion of this barbecue by unlicensed persons may result in improper functioning of the appliance, injury, property damage and may affect your ability to make a claim under the manufacturer's warranty.

Mounting enclosure dimensions when installed with Beefeater hanging bracket BA70HS

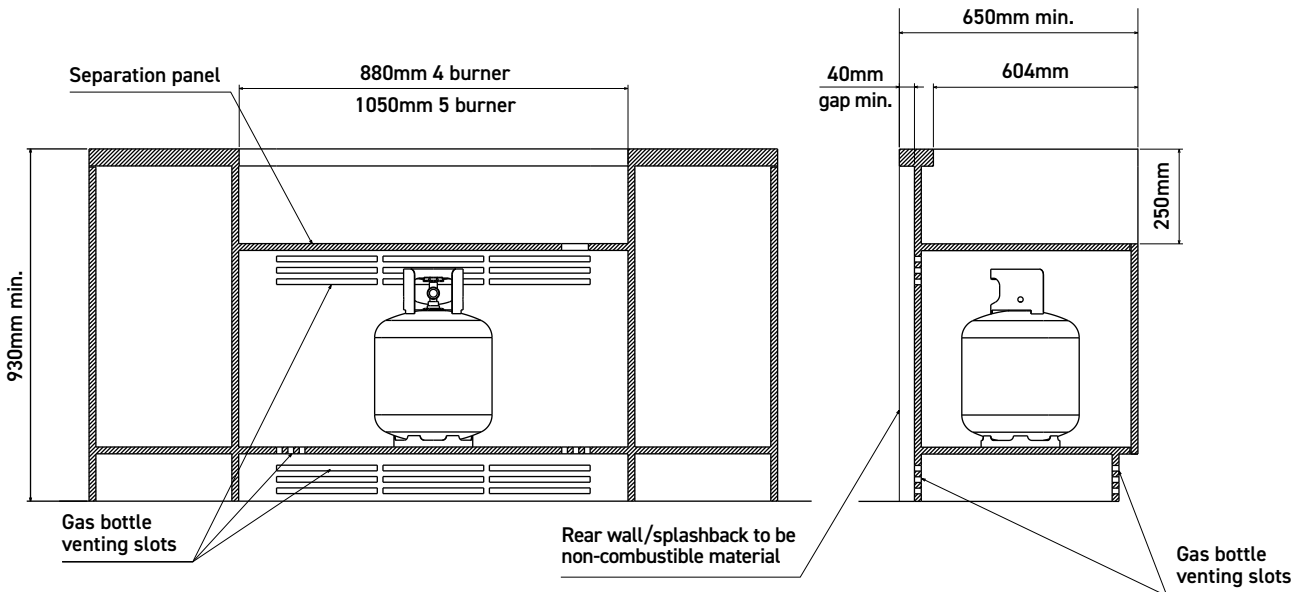

Enclosure construction

- All materials used for the construction of the enclosure and gas bottle compartment must be non-combustible.
- A 40mm min. gap between the enclosure and rear wall is required. This allows for venting of the gas bottle compartment. Vents should also be positioned at the front of the enclosure.
- The cutout size specified above and below allow for a 20mm gap between the back of the barbecue and benchtop. This gap will help maintain air flow around the barbecue.
- The cutout sizes specified above are for use with the Beefeater hanging bracket BA70HS. This bracket is purchased separately as an accessory.
- The cutout sizes specified below are for when the product is installed without hanging brackets. The product rests directly onto its base.

Enclosure ventilation requirements

AS5601 ventilation requirements for 9kg cylinder storage are:

- Where of sheet metal or similar impervious construction there shall be ventilation openings at the top and bottom of the enclosure or recess, each opening providing a free area of at least 200cm² for every cylinder enclosed.
- For LPG installations having enclosed cabinetry below the separation panel that does not contain a gas bottle, low level venting must be installed. This is to allow the gas which is heavier than air to escape from the enclosure in the situation where there may be a leak. A minimum opening of 200cm² is required.

Mounting enclosure dimensions when installed without hanging brackets

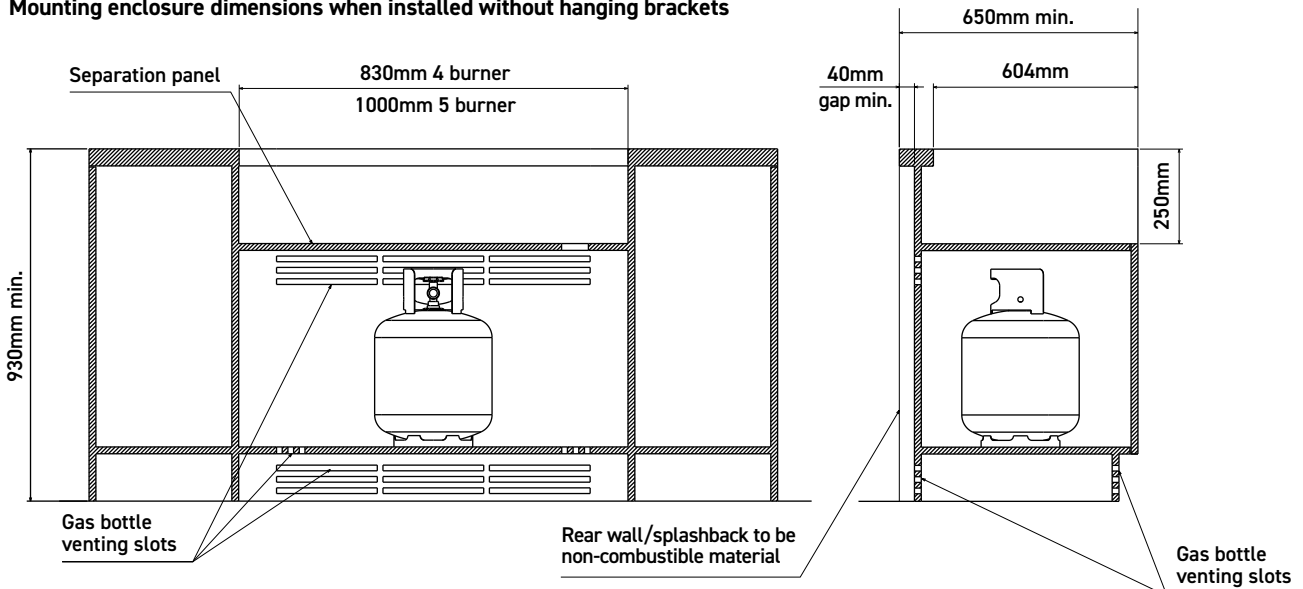

ASSEMBLING THE BARBECUE

Tools required:

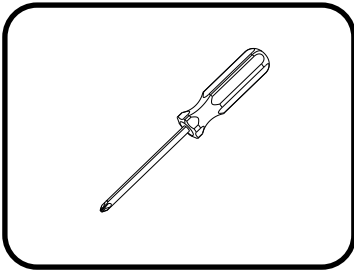

Fasteners supplied (with hanging bracket kit)



The barbecue can be mounted into the enclosure by using the BeefEater hanging bracket kit BA70HS or by resting the barbecue directly on its base. See step 1-4 for mounting of the hanging bracket kit.

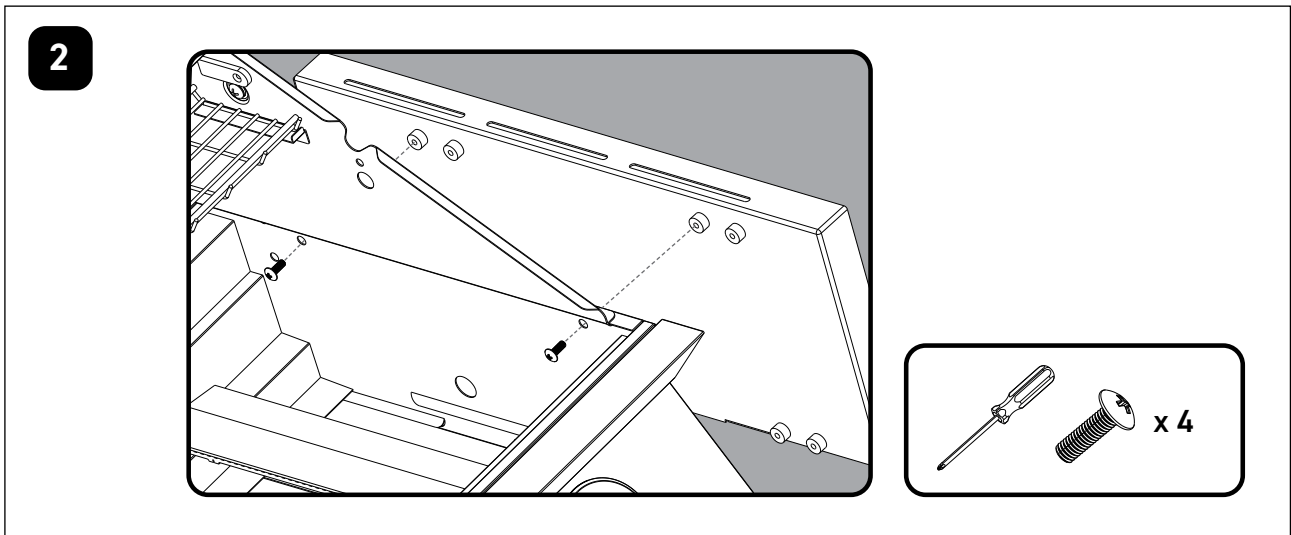
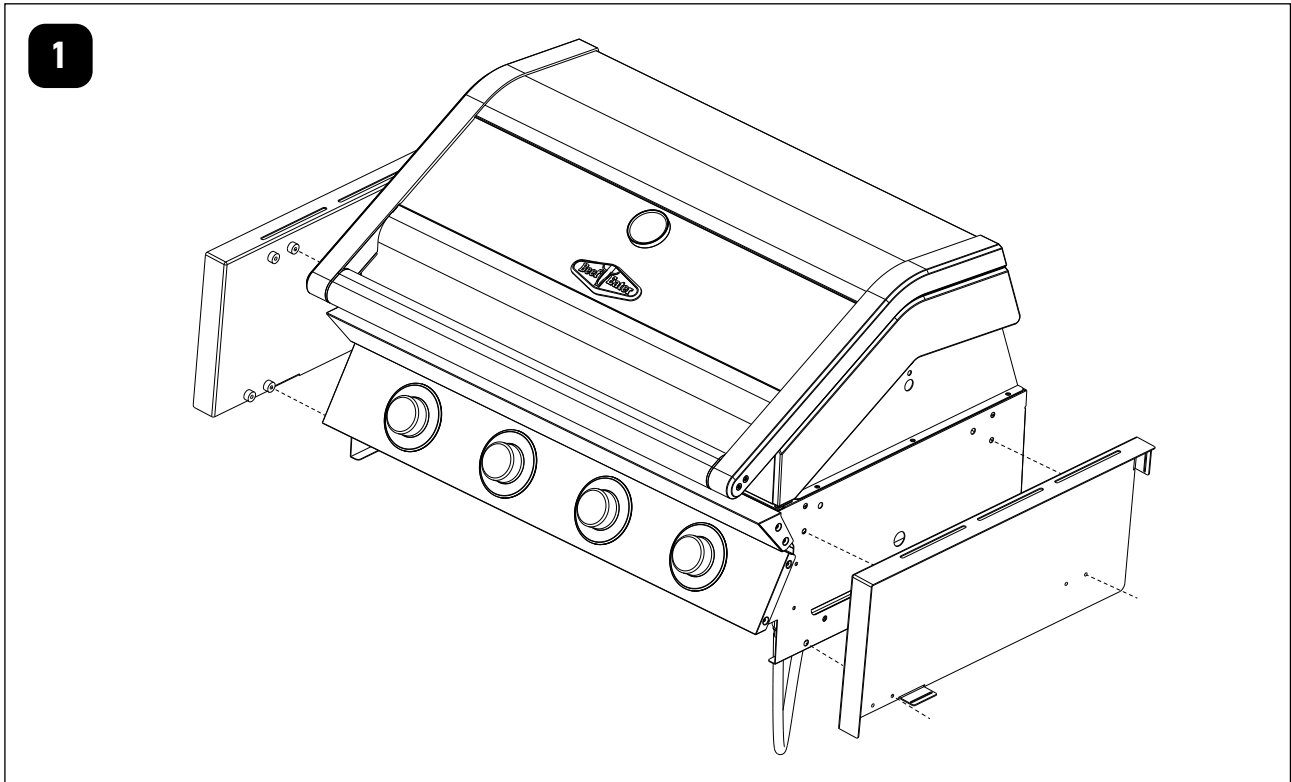

3

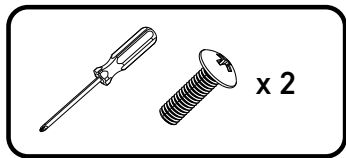
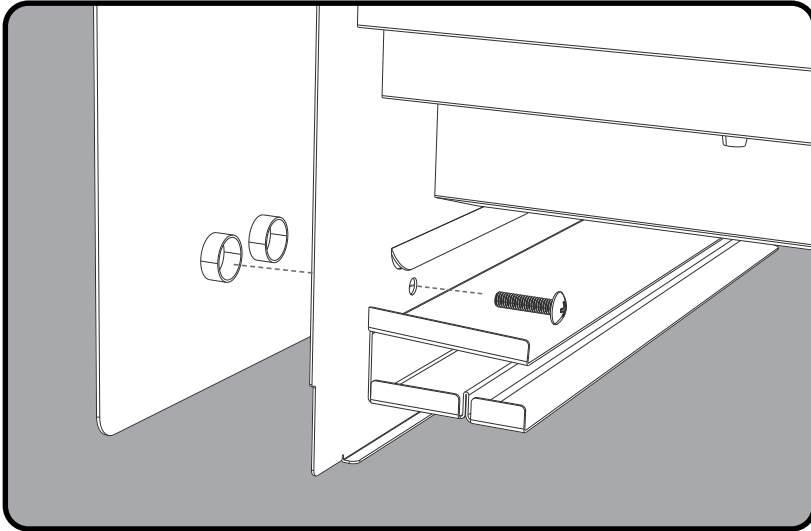

4

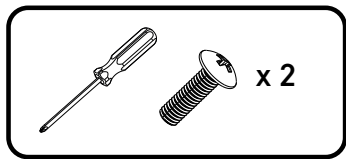
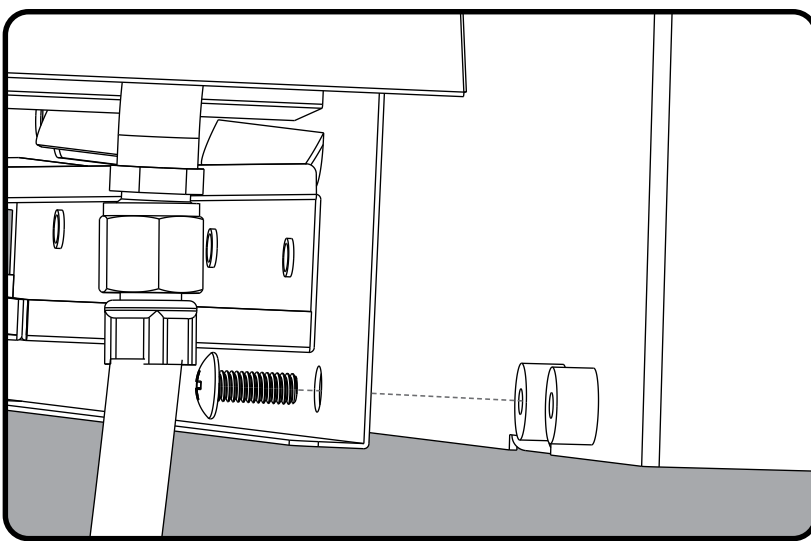

ASSEMBLING THE BARBECUE

5

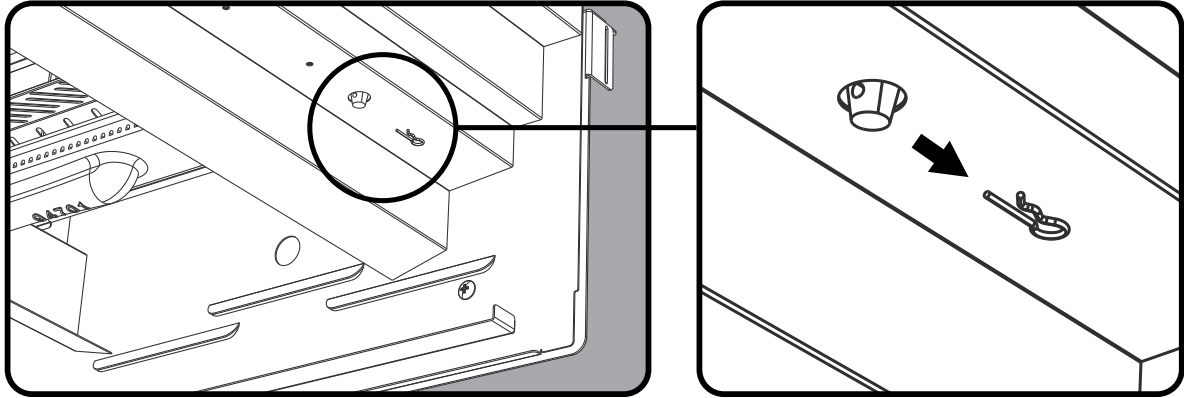

x 3, 4 or 5

6

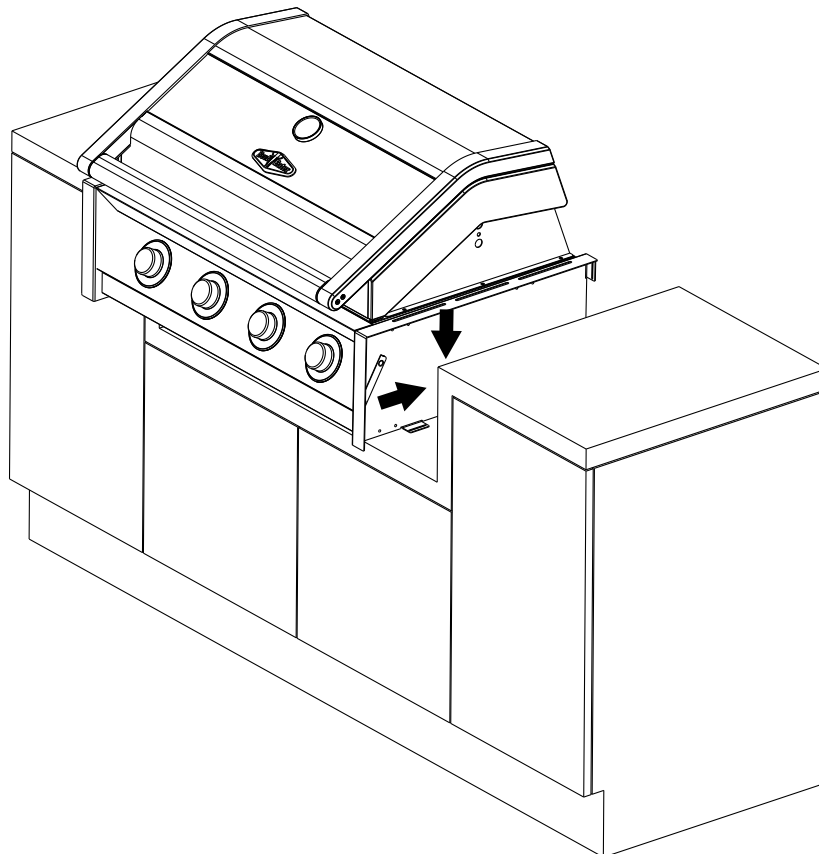

7

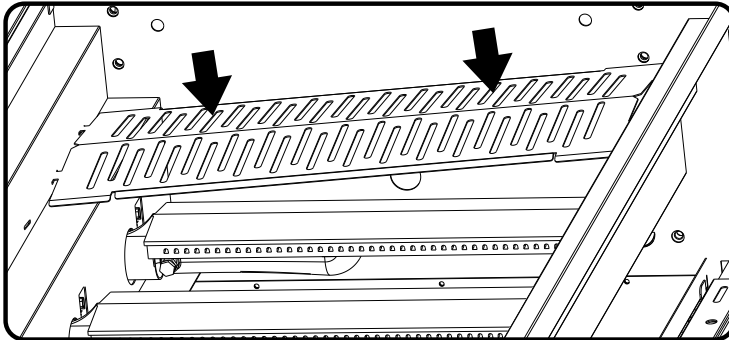

Install the flame tamers above the burners that will be under a grill plate. See below for configuration.

For 4 burner models:

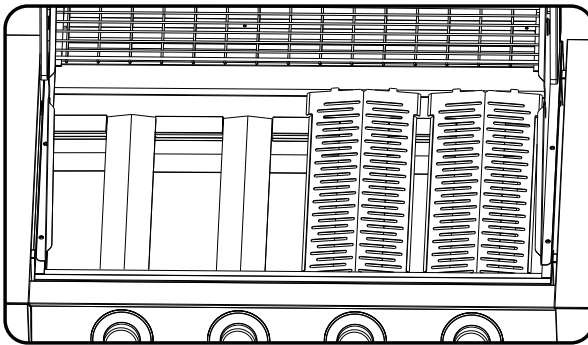

For 5 burner models (to suit Option 1 plate and grill setup, see Step 8, page 13):

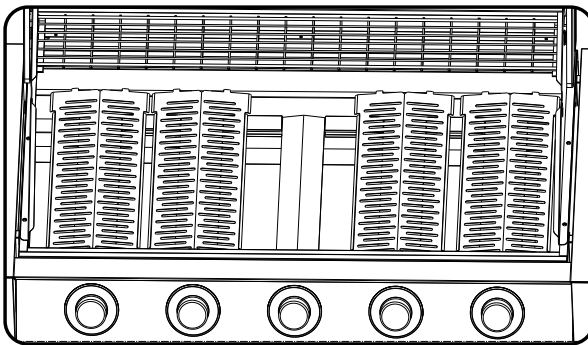

For 5 burner models (to suit Option 2 plate and grill setup, see Step 8, page 14):

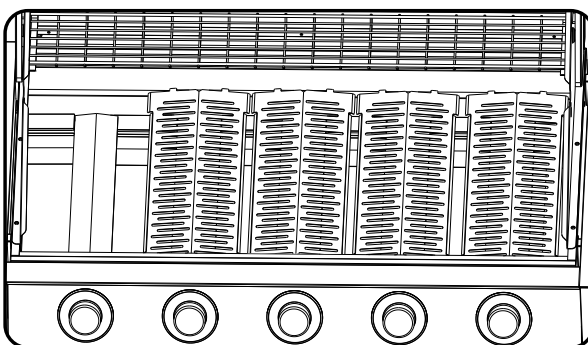

8

Install the solid plate and grill/s in one of the below configuration options, in order to keep the fat drainage hole from being placed directly above a burner. For easier installation, place the solid plate first, followed by the grill plates.

For 4 burner models:

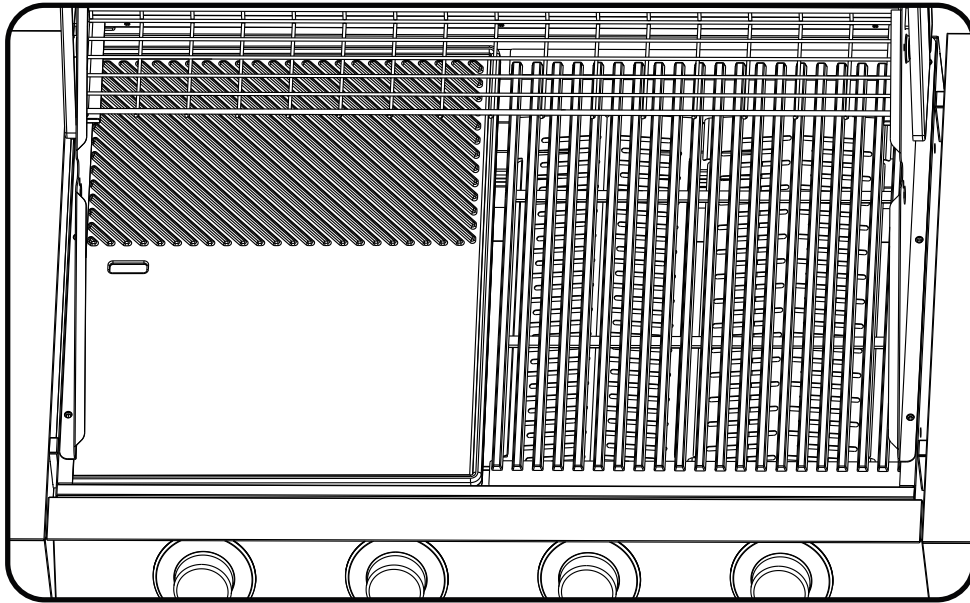

For 5 burner models:

Option 1

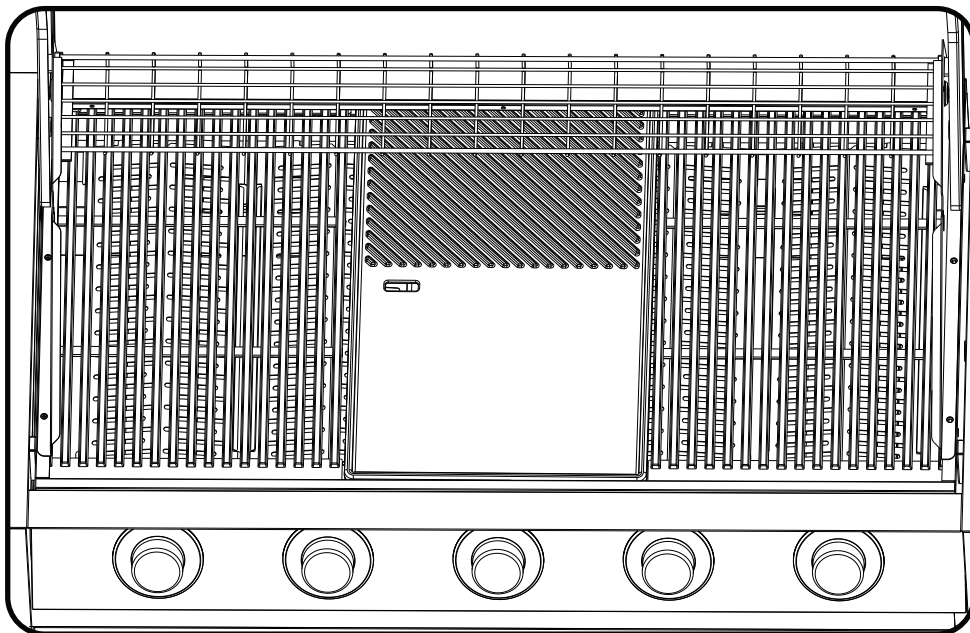

8

For 5 burner models:
Option 2

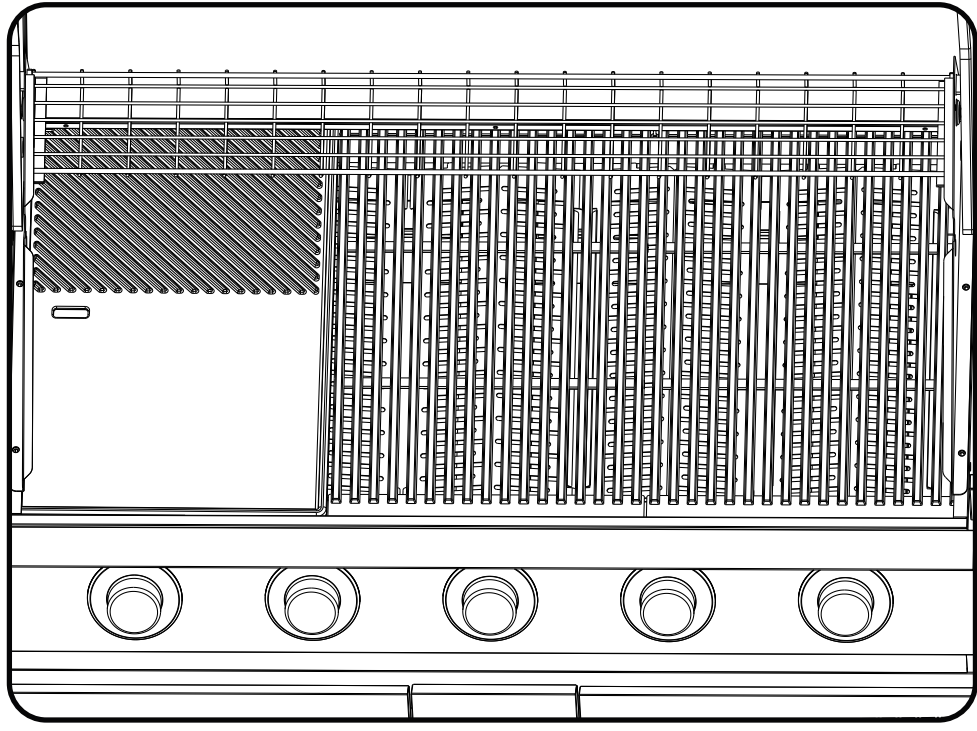

9

Plate and grill removal

The plate and grill may be removed for cleaning following below steps:

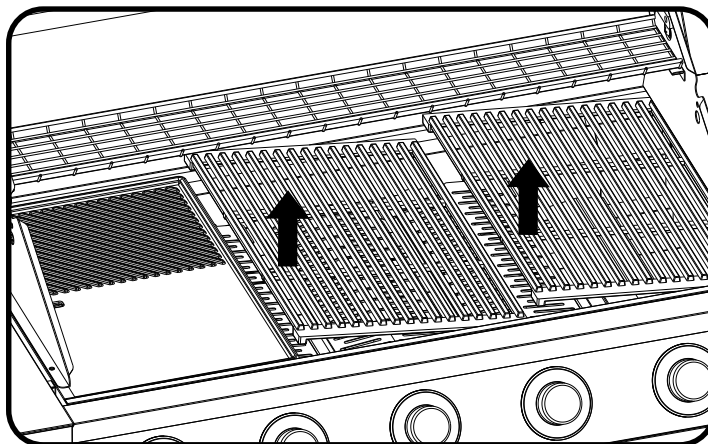
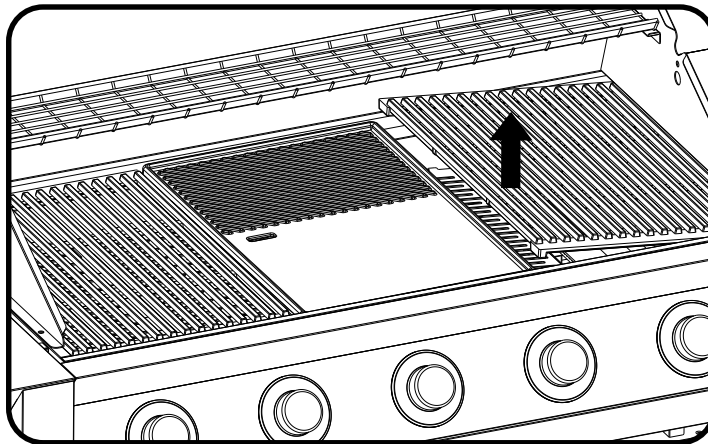
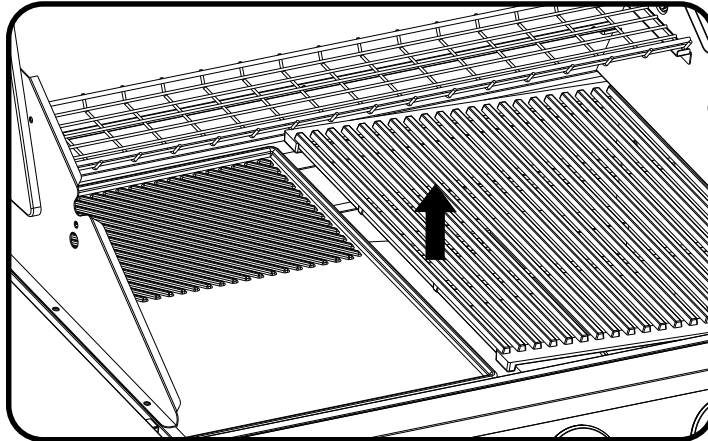

First lift up the grill from the centre edge as pictured, then remove the solid plate (and 2nd grill if fitted) for cleaning.

10

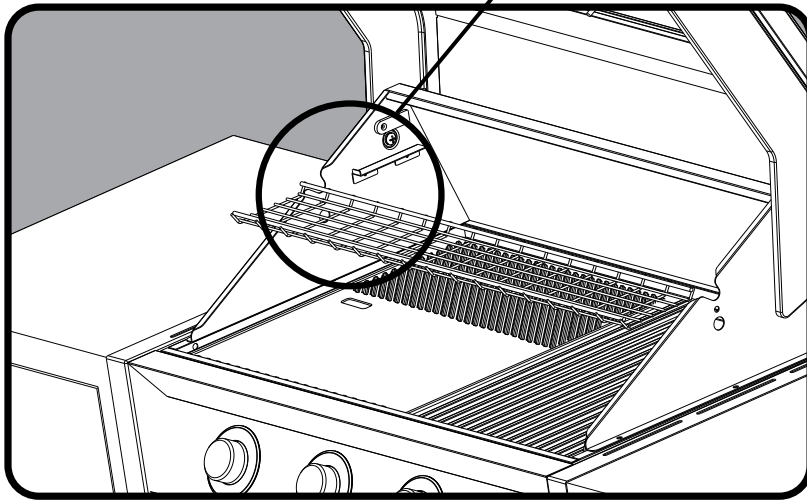
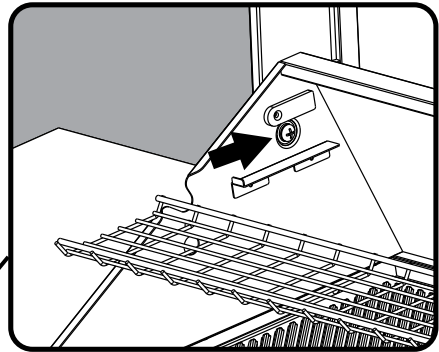

11

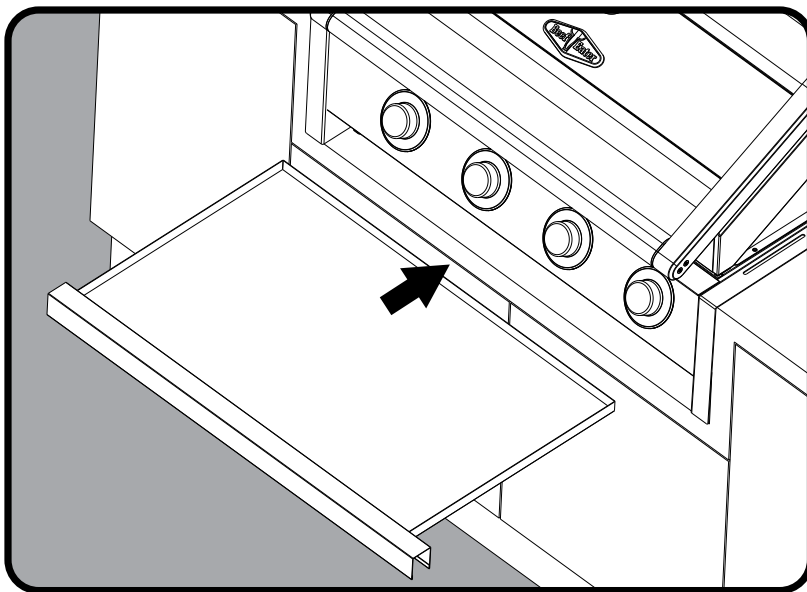

BURNER REMOVAL, FITTING AND LEAK TEST PROCEDURE

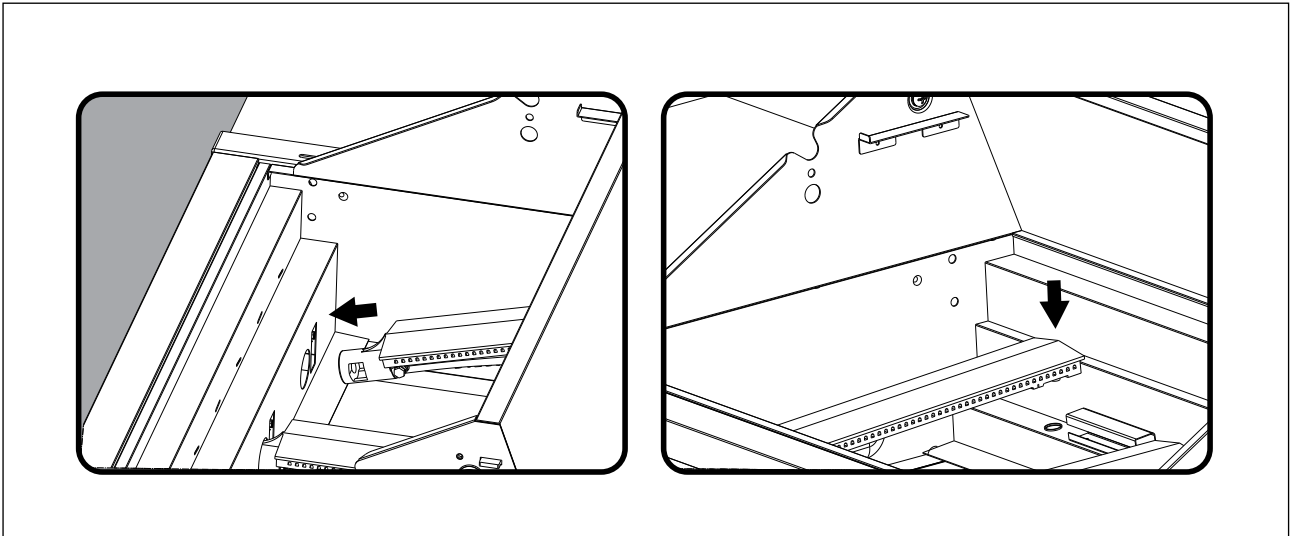

IMPORTANT

After completing the gas hose connections, conduct a leak test following the leak test procedure before using the appliance.

WARNING

To ensure gas tight connections, complete the gas leak test procedure before and after gas hose connection and after every reconnection of the gas cylinder. Failure to do so may result in a fire or explosion.

Leak test procedure

- Ensure all gas valves are in the 'OFF' position.
- In a small container, mix a solution of water and detergent or soap.
- After connection of the hose, turn on the gas supply at the gas bottle.
- Using a brush apply the solution to all gas connection points and look for bubbles forming.
- Bubbling will indicate a leak.
- Turn off the gas supply and re-tighten the joint. Repeat the leak test.
- If the leak persists, turn off the gas at the bottle and contact a licensed gas fitter to correct.

Control functions

Before lighting the barbecue:

- Check that all hoses and gas fittings are tight
- Open the roasting hood
- Check all control knobs are in the 'OFF' position
- Ensure that the cooking surfaces are clean
- Turn the gas isolation valve 'ON'

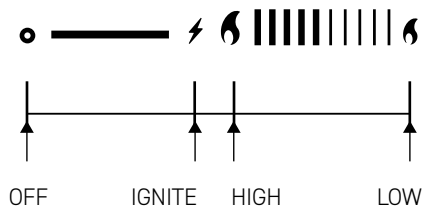
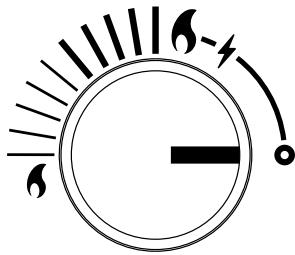

Lighting instructions

- Do not attempt to light burners with the cooking surfaces covered
- Read instructions before lighting
- To light a burner, depress the knob and rotate to . The starter mechanism will click and the burner will light
- If burner did not light, depress knob and turn back to the 'OFF' position
- Allow several minutes for gas to disperse then repeat lighting procedure
- Once ignited, the knob can then be turned to the desired heat setting. The knob does not need to be pushed in while selecting the heat setting

Direct cooking method

This method of cooking can be done with the hood either closed or open.

Commonly used for traditional barbecuing. Place food over the lit grill section. Excess flaring may occur, so care must be taken while cooking. If direct cooking with the lid closed, always check inside the roasting hood regularly. The direct cooking method is recommended for steaks, chops, sausages, and hamburgers.

Indirect cooking method

This method of cooking requires the hood to be closed.

Indirect cooking involves little or no heat directly underneath the food. Instead, the food is placed on the grill, the burners below the food are turned off or Low, and burners on either side are used. The hood is closed to trap heat and moisture. With this method, heat circulates around the food, cooking by convection. By trapping the vapour inside your "outdoor oven," the cooking vapour will fall back on the food on all sides, not just from underneath. The food cooks more evenly, and stays moist in the process.

Indirect cooking is similar to using a conventional oven and is recommended for rotisserie cooking, roasts, poultry, casseroles, vegetables and whole fish.

Reposition the grill plates

To achieve the best heat circulation around the food, it is best to remove the hotplate from the barbecue and position the two grill plates in the centre. Reposition the vaporisers from above the 2 outside burners to above the inside burners. This will give unrestricted heat circulation from the 2 outside burners.

Preheating your Barbecue

Like an oven, preheating your barbecue before cooking produces better results. Because your hood retains heat so efficiently, preheating your barbecue is quicker with the hood down.

Turn all burners to high. Close the hood, and allow to preheat for about 5 minutes. Then reduce the burner settings to achieve and maintain the required temperature, by following these guidelines.

Maintain the right cooking temperature

CAUTION

Do not exceed the temperature warning on the temperature gauge. Operating the barbecue above this temperature may cause damage to the appliance. Your hood is designed to keep the heat in, so requires constant monitoring.

These two charts tell you how hot and how long to cook various types of meat, and the approximate burner settings to help you achieve these results.

MODEL	BURNERS
Four burner	Two inside burners off Two outside burners to medium
Five burner	Three inside burners off One outside burner to high Other outside burner to medium

TYPE OF MEAT	COOKING TEMPERATURE	APPROXIMATE COOKING TIMES	
Beef	180°C/355°F	45–55min per kg	20–25min per lb
Lamb	180°C/355°F	45–55min per kg	20–25min per lb
Pork	170°C/340°F	55–60min per kg	25–30min per lb
Veal	160°C/320°F	40–50min per kg	18–23min per lb
Poultry	180°C/355°F	40–50min per kg	18–23min per lb
Seafood	150°C/300°F	20–30min per kg	9–15min per lb

You may find it useful to purchase a meat thermometer to help take the guess work out of cooking.

Meats such as beef, lamb, veal and pork should be about 70°C/160°F when medium. Chicken and turkey should be 85–90°C/185–195°F.

Most importantly, do not allow your barbecue to overheat. Your hood is designed to keep the heat in, and also requires constant monitoring.

Do not use more than 2 burners on high at any one time.

During cold or windy conditions, more heat is required.

Finally, resist the temptation to keep opening the hood while cooking. This will help to maintain a constant temperature, and minimise cooking time.

CLEANING AND CARE

The cleaning and care instructions are essential for the proper functioning and operation of your appliance over time. Failure to adhere to these care instructions may affect your ability to make a claim under the manufacturer's warranty.

Cleaning Enamel burner box

Although porcelain enamel will keep its lustrous finish even under adverse conditions, it still needs regular cleaning. After the appliance has been used, wash down the surfaces with hot soapy water. Caustic cleaners should be avoided. For barbecues near the ocean or salt-water environment, more frequent cleaning and servicing should be conducted. Wash regularly, rinse and then dry before covering. (In a salt water or marine environment, more rapid deterioration can be expected which is not covered by warranty).

Cleaning Plates and Grills

Many food acids, marinades, juices and sauces contain highly acidic elements that will slowly attack the surface of the plates and grills if not removed after cooking.

- After use, remove all solid material from the cooking surfaces using a brass bristle brush or plastic scourer. Brushes specifically designed for this purpose can be purchased from your BeefEater retailer. Wipe off remaining residue with a paper towel.
- Wash the surface of the grills with a soft sponge and a solution of hot water and a mild dishwashing liquid. Do not use highly caustic, harsh or abrasive chemical cleaners to clean the cooking grills. Always check the manufacturer's recommendations for the cleaner prior to use.
- Coat the grills with a layer of cooking oil. This will help protect the surfaces between uses.

Cleaning the grease tray

Never remove the grease tray while the barbecue is hot. Always remove and clean the grease tray after the unit has cooled down.

Replace aluminium foil drip tray and clean grease tray at regular intervals to prevent grease build-up. Otherwise, a grease fire could result and void the barbecue warranty.

Cleaning the control panel and hood

Wash the surfaces of the control panel and hood with a soft sponge and a solution of hot water and a mild dishwashing liquid. Do not use highly caustic, harsh or abrasive chemical cleaners or scouring pads as these will damage the surface of the panels.

Cleaning the Burners

- Check main opening of burner regularly for insect nests (eg. wasp, ants or spiders). Nests are dangerous and must be cleaned out thoroughly.
- Remove burners periodically and scrub clean with soapy water and a wire brush making sure that the ports are free of obstructions.

Replace burners in the correct position and dry by lighting each one to avoid subsequent corrosion.



CAUTION

A clogged burner can lead to a fire beneath the grill.

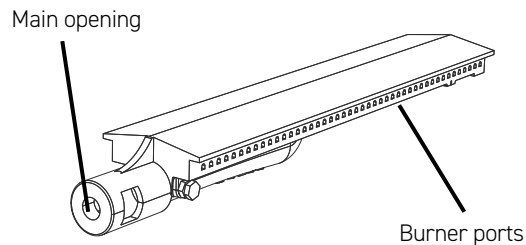

Inspecting the hose and Regulator Assembly and Cylinder

- Inspect the hose and regulator assembly for abrasion, aging or any damage that may result in a gas leak at periodic intervals, at least once a year, and whenever replacing a cylinder.

Replace the assembly if necessary to ensure safe operation.

After connecting the assembly to a cylinder always carry out a leak check.

Only connect the appliance to cylinders that are current according to the date marking on the cylinder.

Storing your Barbecue

When storing barbecue for extended periods, be certain all controls and cylinder valves are turned off.

Gas cylinders must be stored outdoors, out of reach of children and must not be stored in a building, garage or any other enclosed area.

The barbecue should be covered when not in use. A barbecue cover is available as an accessory.

The gas cylinder supply valve must be turned off when the appliance is not in use.



WARNING

Note: For storage and cylinder exchange, disconnect hose at the cylinder only, do not disconnect hose from appliance.

PROBLEM	CAUSE	CHECK
Barbecue will not light	Ignition system not working	Check to see visible spark at starter probe - if no spark is present when control knob is turned then the unit may need to be serviced or replaced. Contact your BeefEater dealer. Check that there is a visible flame coming from the pilot ignition tube. Check that the pilot ignition tube is not blocked by spider webs or insect nests.
	Turning on gas control too quickly	Allow at least 5 seconds for gas to flow through burner before ignition.
	No gas flow	Check that valve on gas cylinder is turned on. Check that burner ports are free of obstructions. Check that all gas injectors are clean and free of obstructions.
	Burners not assembled correctly	Check that burners are correctly positioned in the barbecue frame.
	Burner ports or throat blocked	Check that the burner ports are not blocked by spider webs or insect nests. Clean out as required.
Barbecue lights but goes out soon after starting	Fuel supply turned off	Turn on gas valve at cylinder.
	Gas cylinder low or empty	Replace cylinder and carry out a leak check.
	Kink in gas hose	Check that the gas line is not kinked or twisted.
	Wind or breeze affecting operation	Ensure that the appliance is located out of the way of wind.
Burners will not cross light from one to the other		Check that cross light channel is in place. Check that burner ports are free of obstructions.
Low flame level or low heat output	Burners will not cross light	Check you are running on correct gas Check gas injector size is correct.

GAS CONSUMPTION

Gas Consumption LPG

Model	Barbecue Burners	Side Burners	BTU/hr	MJ/hr	kW	g/hr
BBG1640SA	4	0	56,869	60	16.7	1191
		1	72,034	76	21.1	1509
BBG1650SA	5	0	71,086	75	20.8	1489
		1	86,251	91	25.3	1806
BBG1640DA	4	0	64,452	68	18.9	1350
		1	79,617	84	23.3	1667
BBG1650DA	5	0	80,564	85	23.6	1867
		1	95,730	101	28.1	2004

Gas Consumption NG

Model	Barbecue Burners	Side Burners	BTU/hr	MJ/hr	kW
BBG1640SA	4	0	56,869	60	16.7
		1	71,086	75	20.8
BBG1650SA	5	0	71,086	75	20.8
		1	85,304	90	25.0
BBG1640DA	4	0	64,452	68	18.9
		1	78,669	83	23.1
BBG1650DA	5	0	80,564	85	23.6
		1	94,782	100	27.8



Gas Type		Natural Gas				Universal LPG			
Injector orifice diameter - barbecue burner	BMG1641SA	1.80				1.10			
	BMG1651SA	1.80				1.10			
	BMG1641DA	1.90				1.15			
	BMG1651DA	1.90				1.15			
Injector orifice diameter - side burner		1.80				1.15			
Gas consumption	Barbecue burners	4	5	4	5	4	5	4	5
	Side burners	No		Yes		No		Yes	
	BMG1641SA Total Gas Consumption (MJ/h)	60	75	75	90	60	75	76	91
	BMG1651SA Total Gas Consumption (MJ/h)	60	75	75	90	60	75	76	91
	BMG1641DA Total Gas Consumption (MJ/h)	68	85	83	100	68	85	84	101
	BMG1651DA Total Gas Consumption (MJ/h)	68	85	83	100	68	85	84	101
Regulator Pressure (kPa)		1.00				2.75			

Electrolux Warranty

FOR SALES IN AUSTRALIA AND NEW ZEALAND
APPLIANCE: BEEFEATER 1600 SERIES BBQ

This document sets out the terms and conditions of the product warranties for BeefEater 1600 series BBQ. It is an important document. Please keep it with your proof of purchase documents in a safe place for future reference should there be a manufacturing defect in your Appliance. This warranty is in addition to other rights you may have under the Australian Consumer Law.

1. In this warranty:

- (a) 'ACL' or 'Australian Consumer Law' means Schedule 2 to the Competition and Consumer Act 2010;
- (b) 'Appliance' means any Electrolux product purchased by you and accompanied by this document;
- (c) 'ASC' means Electrolux's authorised serviced centres;
- (d) 'BeefEater' is the brand controlled by Electrolux Home Products Pty Ltd of 163 O'Riordan Street, Mascot NSW 2020, ABN 51 004 762 341 in respect of Appliances purchased in Australia and Electrolux (NZ) Limited (collectively "Electrolux") of 3-5 Niall Burgess Road, Mount Wellington, in respect of Appliances purchased in New Zealand;
- (e) 'Warranty Period' means the period specified in clause 3 of this warranty;
- (f) 'you' means the purchaser of the Appliance not having purchased the Appliance for re-sale, and 'your' has a corresponding meaning.

2. Application: This warranty only applies to new Appliances, purchased and used in Australia or New Zealand and is in addition to (and does not exclude, restrict, or modify in any way) other rights and remedies under a law to which the Appliances or services relate, including any non-excludable statutory guarantees in Australia and New Zealand.

3. Warranty Period: Subject to these terms and conditions, this warranty continues for in Australia for a period of 24 months and in New Zealand for a period of 24 months, following the date of original purchase of the Appliance. Specific components are warranted against manufacturing defects in Australia and New Zealand for the periods listed below;

- Burner Box - Further 3 years.

4. Repair or replace warranty: During the Warranty Period, Electrolux or its ASC will, at no extra charge if your Appliance is readily accessible for service, without special equipment and subject to these terms and conditions, repair or replace any parts which it considers to be defective. Electrolux may, in its absolute discretion, choose whether the remedy offered for a valid warranty claim is repair or replacement. Electrolux or its ASC may use refurbished parts to repair your Appliance. You agree that any replaced Appliances or parts become the property of Electrolux.

5. Travel and transportation costs: Subject to clause 7, Electrolux will bear the reasonable cost of transportation, travel and delivery of the Appliance to and from Electrolux or its ASC. Travel and transportation will be arranged by Electrolux as part of any valid warranty claim.

6. Proof of purchase is required before you can make a claim under this warranty.

7. Exclusions: You may not make a claim under this warranty unless the defect claimed is due to faulty or defective parts or workmanship. This warranty does not cover:

- (a) light globes, batteries, filters or similar perishable parts;
- (b) parts and Appliances not supplied by Electrolux;

- (c) cosmetic damage which does not affect the operation of the Appliance;
- (d) damage to the Appliance caused by:
 - (i) negligence or accident;
 - (ii) misuse or abuse, including failure to properly maintain or service;
 - (iii) improper, negligent or faulty servicing or repair works done by anyone other than an Electrolux authorised repairer or ASC;
 - (iv) normal wear and tear;
 - (v) power surges, electrical storm damage or incorrect power supply;
 - (vi) incomplete or improper installation;
 - (vii) incorrect, improper or inappropriate operation;
 - (viii) insect or vermin infestation;
 - (ix) failure to comply with any additional instructions supplied with the Appliance;

In addition, Electrolux is not liable under this warranty if:

- (a) the Appliance has been, or Electrolux reasonably believes that the Appliance has been, used for purposes other than those for which the Appliance was intended, including where the Appliance has been used for any non-domestic purpose;
- (b) the Appliance is modified without authority from Electrolux in writing;
- (c) the Appliance's serial number or warranty seal has been removed or defaced.

8. How to claim under this warranty: To enquire about claiming under this warranty, please follow these steps:

- (a) carefully check the operating instructions, user manual and the terms of this warranty;
- (b) have the model and serial number of the Appliance available;
- (c) have the proof of purchase (e.g. an invoice) available;
- (d) telephone the numbers shown below.

9. Australia: For Appliances and services provided by Electrolux in Australia: Electrolux goods come with guarantees that cannot be excluded under the Australian Consumer Law. You are entitled to a replacement or refund for a major failure and for compensation for any other reasonably foreseeable loss or damage. You are also entitled to have the Appliance repaired or replaced if the Appliance fails to be of acceptable quality and the failure does not amount to a major failure. 'Acceptable quality' and 'major failure' have the same meaning as referred to in the ACL.

10. New Zealand: For Appliances and services provided by Electrolux in New Zealand, the Appliances come with a guarantee by Electrolux pursuant to the provisions of the Consumer Guarantees Act, the Sale of Goods Act and the Fair Trading Act. Where the Appliance was purchased in New Zealand for commercial purposes the Consumer Guarantee Act does not apply.

11. Confidentiality: You accept that if you make a warranty claim, Electrolux and its agents including ASC may exchange information in relation to you to enable Electrolux to meet its obligations under this warranty.

Important Notice

Before calling for service, please ensure that the steps listed in clause 8 above have been followed.

AUSTRALIA	FOR SERVICE or to find the address of your nearest authorised service centre in Australia PLEASE CALL 1300 307 939 <small>For the cost of a local call</small>	FOR SPARE PARTS or to find the address of your nearest spare parts centre in Australia PLEASE CALL 13 13 50 <small>For the cost of a local call</small>
NEW ZEALAND	FOR SERVICE or to find the address of your nearest authorised service centre in New Zealand PLEASE CALL 0800 10 66 10	FOR SPARE PARTS or to find the address of your nearest spare parts centre in New Zealand PLEASE CALL 0800 10 66 20

For more information on all Beefeater products,
or for dimension and installation information,
call into your retailer, phone or email our customer
care team or visit our website:

AUSTRALIA

phone: 1300 307 939
fax: 1800 356 669
email: customercare@electrolux.com.au
web: beefeaterbbq.com

NEW ZEALAND

phone: 0800 436 245
fax: 0800 225 088
email: customercare@electrolux.co.nz
web: beefeaterbbq.com

BeefEater. We are part of the Electrolux Family.
To add a touch of professional inspiration to your home,
visit electrolux.com.au

