

使用說明書

智能蒸氣焗爐

MS5-STR30SC(BK)

請在操作前仔細檢查本說明書。

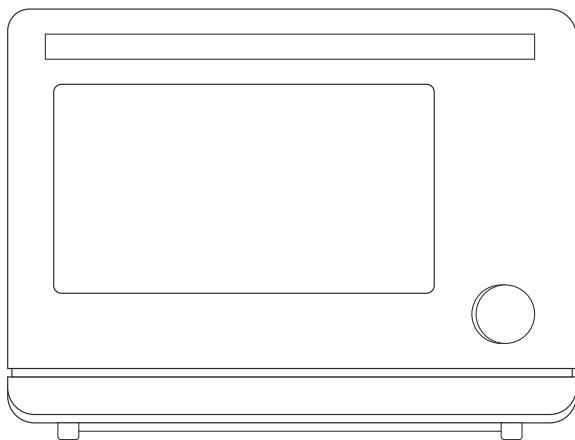

TOSHIBA

目錄

IOT智能控制

產品無線網絡連接	CN-4
如何連接上TSmartLife APP?	CN-5
app的操作界面	CN-8
美食交流圈的使用說明	CN-10

產品安全

預防措施	CN-11
重要安全說明	CN-12

產品介紹

配件	CN-15
安裝注意事項	CN-16
安裝空間及注意事項	CN-17
初次使用	CN-18

清潔和護理

水箱使用	CN-20
首次使用前	CN-21
清潔和維護的預防措施	CN-22

使用說明

操作說明	CN-25
功能總表	CN-26
1. 烹調功能-原味純蒸	CN-27
2. 烹調功能-高溫蒸氣	CN-28
3. 烹調功能-營養慢燉	CN-29
4. 烹調功能-熱風對流	CN-30
5. 烹調功能-蒸氣烤焗	CN-31
6. 烹調功能-上管熱風	CN-32
7. 烹調功能-上管燒烤	CN-33
8. 烹調功能-低溫發酵	CN-34
9. 爐腔預熱功能	CN-35
10. 自動功能(02-03,05-07,09-17,24,33-36) - 需預熱	CN-36
10. 自動功能(01,04,08,18-23,25-32) - 無需預熱	CN-37
10. 自動功能(37-40) - 清潔	CN-38
10. 自動功能設置表	CN-39
爐內燈	CN-41
兒童鎖功能	CN-41
指示燈及其他功能提示	CN-41
其他重要提示	CN-42



維護

疑難解答	CN-43
規格	CN-44

IOT智能控制

產品無線網絡連接

1 連接網絡

按住「」（確定 / 開始）鍵 3 秒，直到“嗶”一聲，“AP” 和閃爍「」顯示出來。如果沒有顯示出來，“N0~N5” 將顯示出來，烤箱將在 30 秒後恢復待機狀態。



2 斷開與網絡的連接

按住並保持「」8 秒，如果連結已成功刪除，螢幕會顯示“8888”，3 秒後回到待機狀態；如果連接失敗，螢幕會顯示“FFFF”，烤箱會在 3 秒後回到待機狀態



- 目前僅支持1個主帳戶分享給其他家庭成員共同使用
(即不可同時有多於1個的主帳戶控制產品)

如何連接上TSmartLife APP?

1 下載 TSmartLife App

掃描QR code，或從應用程式下載

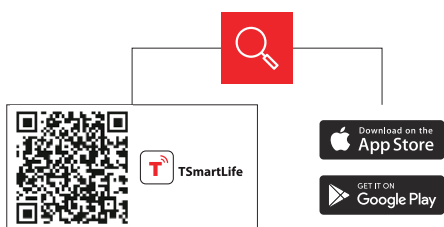

2 註冊或登入

請登入現有帳戶或註冊新帳戶

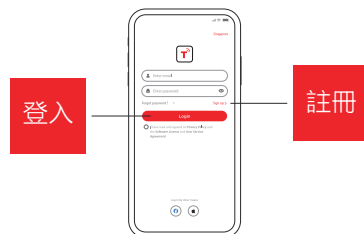

3 將您的設備連接到 TSmartLife

第一步

連接無線網絡 (wifi)，
開啟藍牙

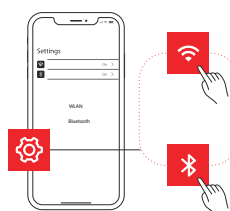

第二步

打開 TSmartLife App
設備連上電源

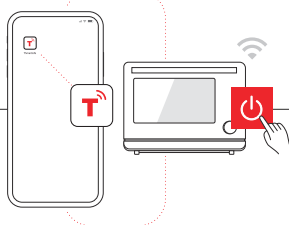

第三步

通過以下方式添加設備：

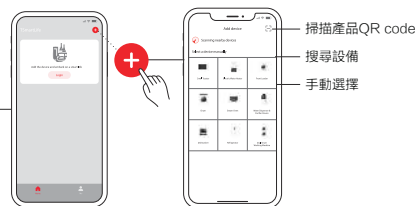

第四步

確保設備和應用程式
處於同一無線網絡環境下



第五步

長按面板上的「」3秒
根據應用程式指示設置，
產品將自動連接



第六步

您可為產品重新命名，
亦可嘗試遠距離控制



如何連接上TSmartLife APP?

小貼士

- 請確保產品連接電源；
- 連接期間，請將您的手提電話貼近產品；
- 請將您的手提電話連接到家中無線網絡（wifi）；
- 請在您的無線網絡路由器上啟用2.4GHz頻率（暫時不支援5GHz網絡）；
- 請注意：產品無法連接需要認證的無線網絡（wifi）或公共網絡（如酒店、餐廳等）。
- 建議使用僅帶有字母及數字的無線網絡（wifi）。若您的網絡名稱帶有特殊字符，請在路由器上修改；當產品連接網絡時，請停用WLAN+（Android）或WLAN Assistant（iOS）；
- 如欲將產品連接到無線網絡（wifi），請在應用程式主畫面上點擊“+”，根據APP提示，按產品種類、型號重新添加。

TSmartLife APP疑難排除

背景：

雙頻支援為產品提供了選擇和最大的靈活性，從而在家用網路上獲得成功。

家用網路預期有多種  服務可能性，具體取決於其路由器的配置方式。 路由器有四種配置模式：A、B、C和D。

A. 僅2.4GHz，例如較舊型號的  路由器



o 在這種情況下，雙頻無線電將自動以2.4GHz運行

B. 僅5GHz，由於衝突干擾，有些人可能會選擇關閉較舊的2.4GHz頻段

o 在這種情況下，雙頻無線電將自動以5GHz運行

C. 2.4GHz和5GHz共用相同的SSID名稱，例如Johns 

o 在這種情況下， 路由器和雙頻無線電將協商使用的最佳頻率

D. 不同SSID名稱的2.4GHz和5GHz，例如Johns _2G和Johns _5G



o 只有在這種情況下，才能選擇使用哪個  頻段。

電器中配備雙頻無線電意味著除非遇到問題，否則無需更改路由器或路由器配置，在這種情況下，瞭解  路由器配置（見上文A、B、C或D）非常重要。

如果第一次無法加入網路

• 無法找到家庭SSID網路：

o 信號弱... 由於電器無線電是雙頻的，這意味著電器既不接收2.4GHz信號也不接收5GHz信號。僅僅在手機可以看到  信號並不一定意味著電器無線電可以在信號微弱的情況下發現。路由器與電器距離太遠或障礙物過多會大大降低信號。

重新定位路由器可能會稍微改善這種情況。更好的解決方案是使用  中繼器或更高品質的路由器。所有  路由器的傳輸功率都受到聯邦法規的限制，但品質更高的路由器可以更好地在各個方向均勻地傳輸信號，擁有更靈敏的接收器以更好地處理微弱信號，並擁有更高品質的軟體來最大程度地減少連接丟失。

• 可以找到SSID網路但無法加入：

o 網路需要身份驗證... 通常用於餐館或酒店的公共網路。產品不能接受加入網路所需的法律協定。請切換到不需要身份驗證的網路。

o 加密不足... 出於網路安全原因，東芝不推薦產品加入未加密或加密不充分的網路（例如WEP加密）。

o 密碼長度... 出於網路安全原因，東芝建議使用強大密碼，但支援的最大密碼長度為 32 個字元。

o 密碼不正確... 如果嘗試加入與手機當前使用的網路不同的網路，手機中的網路密碼可能不再正確。在這種情況下，需要提供新的憑據。

o SSID名稱不合法... TSmartLife App接受任意SSID名稱，但當嘗試使用某些非字母數字或外語字元加入網路時，應用程式可能會發出警告。

• WLAN+ (Android) 或WLAN Assistant (iOS) 功能已開啟，請關閉並重新連接互聯網。

如果可以加入網路但連接不穩定

對於  配置模式A、B和C，請按照路由器製造商提供的說明對路由器配置進行更改：

• 對於路由器配置A（見上文），如果在路由器中禁用5GHz頻段，東芝建議啟用5GHz頻段，並選擇一個不同的SSID名稱（例如SSID名稱_5G）。按照正常的加入說明加入5GHz網路。如果路由器是較舊的2.4GHz路由器，東芝建議升級到較新的雙頻路由器。

• 對於路由器配置B（見上文），東芝建議啟用2.4GHz頻段（所有提供5GHz的路由器也支援2.4GHz），並選擇一個不同的SSID名稱（例如SSID名稱_2G）。然後按照正常的加入說明加入2.4GHz網路。

• 對於路由器配置C（見上文），東芝建議為2.4GHz和5GHz頻段分配不同的SSID名稱。按照正常加入說明加入其中一個網路，然後按照  模式D的故障排除說明進行操作。

對於這些步驟，不需要更改路由器配置：

• 對於路由器配置D（見上文），可以在更改路由器配置或升級路由器之前嘗試在其他頻段上運行。換句話說，如果使用2.4GHz的連接不穩定，請嘗試使用5GHz。或者，如果使用5GHz的連接不穩定，請嘗試使用2.4GHz。按照下面的說明“如何將網路設置為2.4GHz或5GHz”。

• WLAN+ (Android) 或WLAN Assistant (iOS) 功能已開啟，請關閉並重新連接互聯網。

如果設備離線，請檢查連接狀態。請確認

• 設備是否正常供電。

• 網路信號是否穩定。

•  名稱或密碼有更改，請重新添加設備。

APP的操作界面

界面介紹

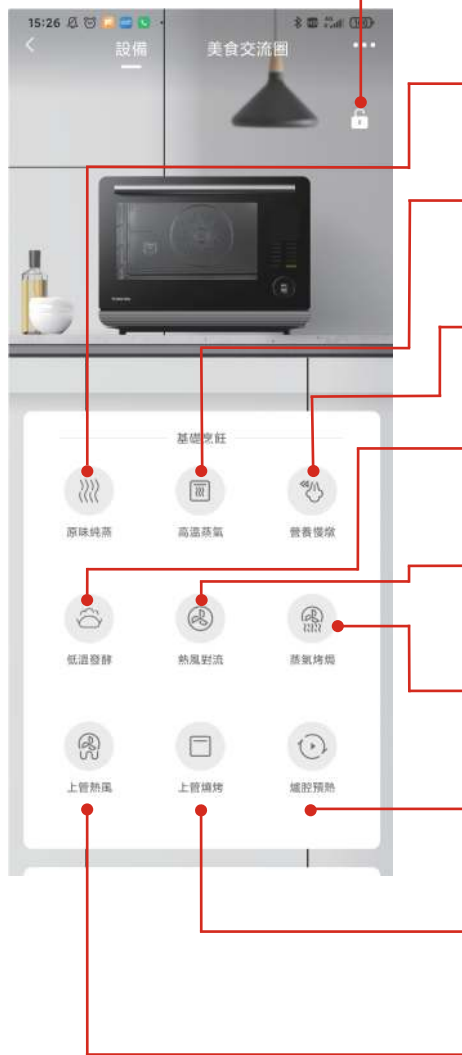

童鎖



原味純蒸



高溫蒸氣



營養慢燉



低溫發酵



熱風對流



蒸氣烤焗



爐腔預熱



上管燒烤



上管熱風

APP的操作界面

如何開始烹飪？

1 選擇所需烹飪程序



2 點擊溫度控制位置



3 滑動溫度數字，選擇所需溫度



4 滑動時間數字，選擇所需時間



5 按[開始]鍵後，手機界面出現提示語



6 根據指引，在焗爐上按[開始]，開始烹飪。



美食交流圈的使用說明

美食交流圈上的食譜

1 選擇美食交流圈



2 選擇心儀的食譜進行烹飪



3 查看食譜，開始烹飪



4 按[一鍵烹飪]鍵後，在上按[開始]，開始烹飪。



預防措施

- (a) 不要試圖在門打開的情況下操作蒸氣。請勿破壞或更改安全連鎖。
- (b) 不要在蒸氣正面和門之間放置任何物體，也不要讓污垢或清潔劑殘留物積聚在密封面上。

注意

如果設備未能保持良好的清潔狀態，其表面可能會退化，使用壽命也會縮短，引致危險情況。

重要安全說明



為降低使用時發生執行期錯誤、觸電、人身傷害的風險，請遵循基本預防措施，包括以下幾點：

閱讀並遵循具體的注意事項。

- 8歲及以上兒童、身體、感官或心智弱能人士，或缺乏經驗及知識人士，需在了解相關風險，並得到監督或指引有關本電器的安全使用方法之下方可使用。兒童不得把玩本產品。除非兒童為 8 歲以上，並且受到監督，否則不得清潔及維護本產品。未滿 8 歲的兒童，除非常時受到看管，否則應遠離產品。
- 請將本電器及其電線放在 8 歲以下兒童接觸不到的地方。
- 電線如有損壞，請由製造商、代理商或具類似資格的專業人士更換，以免發生危險。
- 警告：更換燈泡之前，請確保已關閉產品電源，以免觸電。
- 使用塑膠或紙製容器加熱食物時，請注意蒸氣，因為可能會著火。
- 警告：除了合資格人員外，任何人進行任何檢查或維修等操作都是危險的。
- 僅使用本推薦的溫度探測器。（如蒸氣配備使用溫度感應探針設備。）

本產品供家居及類似環境使用，如：

- 店舖內的員工廚房區域、辦公室及其他工作環境；
- 供客戶於酒店、汽車旅館及其他住宅類型環境；
- 農舍；
- 民宿類型環境。

重要安全說明



- 不得使用蒸氣清潔器清潔產品。
- 警告：使用期間，可接觸部件可能會變熱。幼兒應遠離產品。
- 不得使用蒸氣清洗器。
- 儲物櫃的表面可能會變熱。
- 警告：產品及其可觸及部件在使用期間發熱。注意避免接觸加熱元件。未滿 8 歲的兒童，除非常時受到看管，否則應遠離產品。
- 在使用過程中，產品會變熱。應注意避免接觸產品內的加熱元件。
- 切勿將本產品安裝在裝飾門後面，以免過熱。
- 從產品取走容器時，應注意不要移動轉檯。
- 警告：移動產品時，不要使用手柄。（產品超重時，手柄容易折斷。）
- 每次使用後，應清理收集污水箱、爐內和水箱中的水。
- 請勿使用耐溫性低於120度的紙杯和塑膠容器。並使用適合烹調溫度的容器。可以使用玻璃、陶瓷、不銹鋼器皿。
- 本產品的主要功能是原味純蒸。
- (*注: 如發現爐內有水漬仍為正常現象，因產品先進行了進出水測試。請先將爐內水抹乾。)
- 使用與蒸氣相關的功能時，蒸氣焗爐運轉過程中爐腔內會產生大量蒸氣，爐腔內多餘的蒸氣會通過出風口排出，但少部分蒸氣由於環境溫度，會凝結在出風口處，或部分蒸氣可能從門縫四周漏出，這是正常現象。

請仔細閱讀並保存以備日後參考

重要安全說明



危險

觸電危險



觸摸部分內部組件，可導致嚴重的人身傷害或死亡。
請勿拆解本產品。

警告

觸電危險



- 接地使用不當可導致觸電。在正確安裝產品並將其接地之前，請勿插入電源插座。
- 本產品必須接地。如發生電氣短路，接地可通過為電流提供逃逸通路來降低觸電危險。本產品配備帶有接地線及接地插頭的電源線。插頭必須插入正確安裝並接地的插座。
- 如未充分理解接地說明，或對產品是否正確接地存有疑問，請諮詢合資格電工或維修人員。如需要使用延長線，請僅使用 3 線延長線。

1 產品隨附短電源線，以減低長電源線纏繞及絆到造成的危險。

2 如使用長電源線組或延長線：

- 1) 電源線組或延長線標記的電氣額定值應至少與產品的電氣額定值一樣大。
- 2) 延長線必須為接地型 3 線電源線。
- 3) 應妥善擺放長電源線，使其不會掛在檯面或桌面，以免被兒童拉扯或意外絆倒。

配件



蒸氣焗爐零件和附件名稱

從紙箱中取出蒸氣焗爐及所有材料。蒸氣焗爐配備以下配件：

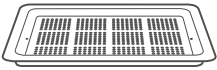

蒸盤

(只能在蒸煮功能下使用)

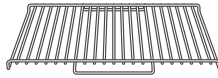

蒸烤架

(燒烤、烘焙以及蒸氣烹飪情況下使用，置於腔體平板使用或配合烤盤使用；有微波功能禁止使用蒸烤架)

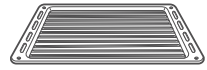

烤盤

(可用於熱風對流和蒸氣烤焗功能。)
(使用時請在托盤上放上錫紙。)



使用說明書

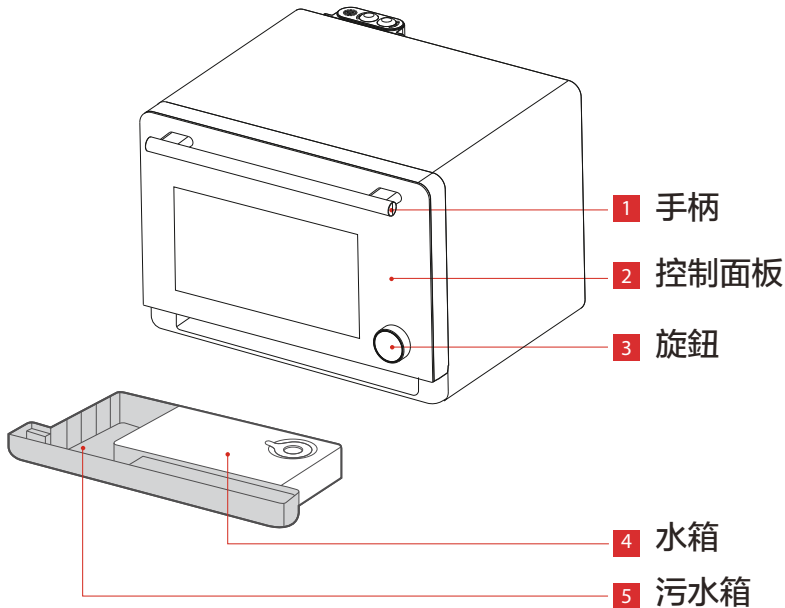

安裝注意事項



- 本設備不被設計於商業環境使用。
- 請遵守提供的安裝說明。注意，此設備只能由合資格技師安裝。
- 設備配有插頭，必定只能連接到正確安裝的接地插座。
- 如果需要新插座，安裝和電纜連接過程必須由合資格電工完成。如果安裝後無法再接觸到插頭，則必須在安裝側安裝接觸間隙至少為 3 mm 的斷極裝置。
- 不得使用轉接器、多路接線板和延長線。超載會導致火災。
- 如果裝置沒有安裝電源線和插頭，連線裝置必須在所有極點上有一個提供完全斷極的觸點間隔。裝置必須按照佈線規則進行固定佈線。



操作期間，可接觸表面可能會變熱。

安裝空間及注意事項



爲了避免從排氣口排出的油和煙污染傢俱，或至烹飪過程中因過熱而造成火災，蒸氣焗爐應與牆壁和櫥櫃保持一定距離。請按照下圖所示，將其放置在安全距離內。

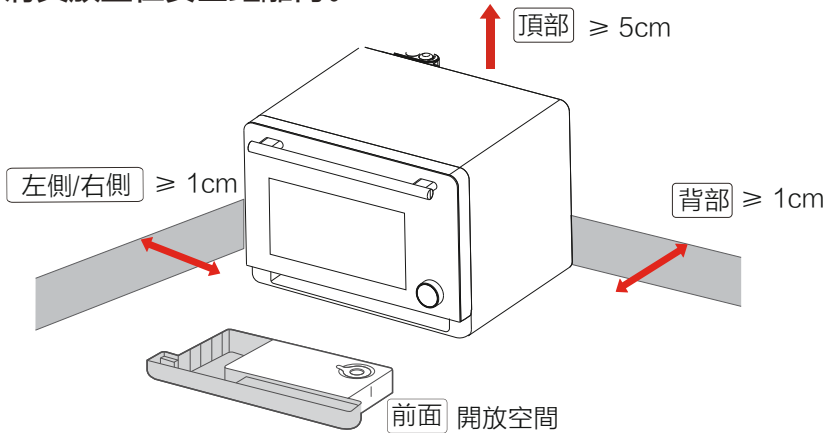

*** 爲避免火災事故或爆炸，請勿此爐或附近加熱或使用易燃材料。**

- 爲了避免使用者受傷和財產損失，產品主體和《使用說明書》包括了許多重要內容，如正確使用方法。
- 圖示和符號爲幫助使用者理解而設計，或與真實產品有所區別。
- 使用前請仔細閱讀相關標籤，並嚴格遵守；請妥善保管它們，以備日後參考。

注意

- 如果實物與圖之間有任何矛盾，應以實物爲準。
- 請參考圖中標記的安全距離來放置產品。
- 本產品爲桌面產品，禁止作爲嵌入式產品使用。

初次使用



使用前請仔細閱讀《使用說明書》，並嚴格遵守；請妥善保管它，以備日後參考。
嚴禁將金屬或異物，如鐵絲、手指等插入蒸氣爐後側的吸氣口、排氣口和百葉窗內。
否則，可能會引致觸電或受傷。如果有任何異物意外插入產品，請拔掉電源線並聯繫我們的客戶服務中心。

排氣口
百葉窗

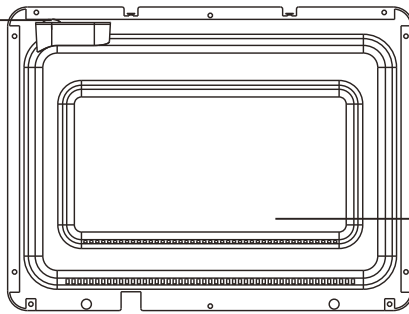

吸氣口

背面圖

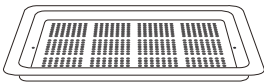

蒸盤（可用於蒸煮功能）

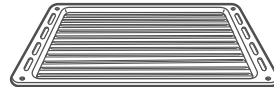

烤盤（可用於熱風對流和蒸氣烤焗功能）

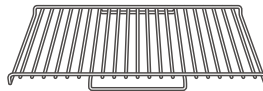

蒸烤架（燒烤、烘焙以及蒸氣烹飪情況下使用，置於腔體平板使用或配合烤盤使用；有微波功能禁止使用蒸烤架）



初次使用



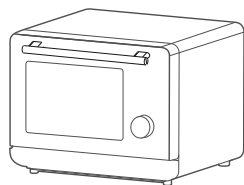

1 打開蒸氣焗爐門，取出所有物件，然後把門關上。

(*注: 如發現爐內有水漬仍為正常現象, 因產品先進行了進出水測試。請先將爐內水抹乾。)

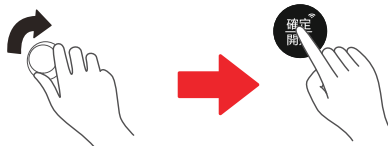

2 加滿水箱，旋轉旋鈕，選擇  自動功能；按  確認。然後將旋鈕旋轉到 [38 爐腔清潔]。



3 按  鍵開始清洗，大約需時 10 分鐘

4 清潔完成後，蜂鳴器會響一次。請隨即開啟烤箱門進行冷卻。

提醒：

- 如發現爐門封條鬆脫，只需用力按回門邊凹槽內即可。
- 清潔後，不要立即用手觸碰爐腔。
- 請待冷卻後，才用軟布擦去爐腔內的積水。
- 在爐腔完全冷卻之前，不要關閉烤箱門。

清潔和護理

水箱使用

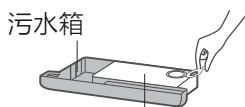
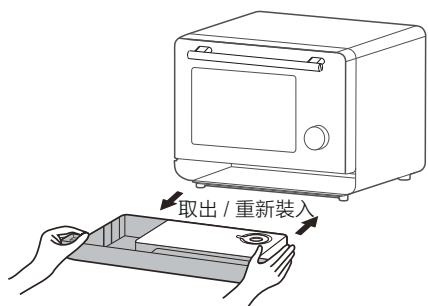

淨水箱

揭開橡膠圈，加入適量的室溫開水/蒸餾水，蓋上橡膠圈，確保它們配合良好。



- 1 在水箱中加入室溫開水/蒸餾水，以免產生水垢影響機器使用壽命。
- 2 烹調後，必須倒去污水箱和水箱中的水，以免滋生細菌。

請及時將水箱裝滿水。

當水箱缺水時，水泵會發出類似蜂鳴聲的提示，提醒使用者機器缺水。此時請及時將水箱加滿水。如果水箱一直處於缺水狀態，機器將發出 5 聲提示音後停止工作，同時螢幕會顯示 [F02]。請將水加到乾淨的水箱中，直到水位達到「MAX」線，然後將水箱重新裝入蒸氣焗爐，繼續烹調。

首次使用前



- **初始清潔。**

拆除蒸氣爐前面的所有保護箔。首次使用前，請參閱“清潔同保養”部分獲取更多資訊。

- **首次清潔同加熱。**

加熱前，最好用濕布擦拭蒸氣焗爐內部。這樣就能夠去除儲存和解凍器具在包裝過程中積聚的爐灰或者殘留的包裝材料。

金屬部件有一層保護塗層，首次加熱時可能會散發輕微氣味。

這種氣味同任何蒸氣會在短時間內消散，並非表示連接或機件有故障。另外，請確保首次加熱時廚房通風良好。

- **請拆下所有配件並在焗爐外清洗。**

新電器首次使用時通常會有異味。首次使用前，請使用自動功能39進行清潔來去除異味。



清潔和維護的預防措施

● 爐門和蒸氣焗爐外殼

- 用微濕的布擦拭。首先用溫和的肥皂擦拭頑漬，然後用微濕的布擦拭。
- **警告** 不要用太大量的水清洗，否則可能會使蒸氣焗爐生鏽，造成損壞。

● 蒸氣排氣口

- 用微濕的布擦拭。進行蒸煮後，在蒸氣排氣口附近會有白色的痕跡（水中的可溶解物質）。以擰乾的膠布小心擦拭。

● 爐腔和爐門（內部）

- 用微濕的布擦拭。有頑漬的部份可以在溫和的肥皂溶液中浸泡30分鐘後再擦拭。
- 進行蒸氣加熱後，等待蒸氣爐冷卻，然後用乾布擦去冷凝水。
- **警告** 不要使用尖銳的物體，如鋼絲刷或叉子，因為這可能造成劃痕或裂縫。

● 爐門封條

- 如果水滴或食物殘渣卡在爐門封條上，請小心地拆下封條。擰乾水分後用軟布擦拭乾淨，然後安裝到正確位置。



警告

1. 清潔時，不要大力刮擦或擦拭封條造成損毀，否則可能引起蒸氣洩漏。
2. 拆卸和安裝封條時要小心，否則可能引起蒸氣洩漏。

清潔和維護的預防措施



- 用蘸有軟性洗滌劑（如洗潔精）的布擦拭蒸氣焗爐外殼，然後用濕布擦拭，最後用乾布擦拭。請勿用硬物（如鋼絲刷）擦拭產品。
請勿清洗門安全鎖系統
 - **警告** 不要使用粗糙的洗滌劑或鋒利的金屬刮刀來清潔爐門玻璃。這可能導致玻璃破損。
- 請保持爐門和爐身接縫位清潔
- 烹飪過程中產生的油脂會腐蝕爐腔，影響加熱效果，改變食物味道。因此，請待爐腔完全冷卻後，用濕布或用軟性洗滌劑浸濕的布清潔。
- 定期用溫水清洗配件。長時間烹飪後，請勿立即用冷水清洗。
- 不要用劣質清潔劑或腐蝕性、揮發性化學溶劑擦拭蒸氣焗爐，以免損壞蒸氣焗爐。

小提示

為避免損壞您的裝置表面，請勿使用：含有蘇打、氨、酸或氯化物的清潔劑 含有除垢劑的清潔劑，如粉末清潔劑和奶油清潔劑，堅硬的研磨海綿和刷子，如鍋鏟，不鏽鋼清洗劑。

清潔和維護的預防措施



- 請勿使用粗糙的洗滌劑或鋒利的金屬刮刀來清潔爐門玻璃。這可能導致玻璃破損。
- 不要把電源線和插頭直接放在外罩上，以免外罩的餘熱損壞電源線。
- 當焗爐處於高溫狀態時，內部蒸氣會膨脹。門在開啟後立即關閉，聽到出於氣壓的空氣流通聲是正常的。這不影響使用。開門後約10 秒，烤箱溫度會略為下降，關門時不會有聲音。

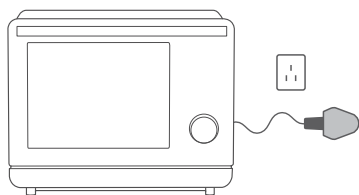

拔掉裝置的插頭，
等待機器完全冷卻。



用蘸有軟性洗滌劑的布擦拭
烘箱外殼，
並以濕布擦拭乾淨。

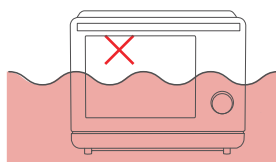

嚴禁將蒸氣焗爐浸泡在水或
其他液體中。

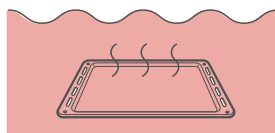

爲了達到最佳的清潔效果，
建議用溫水清洗配件。

操作說明

控制面板

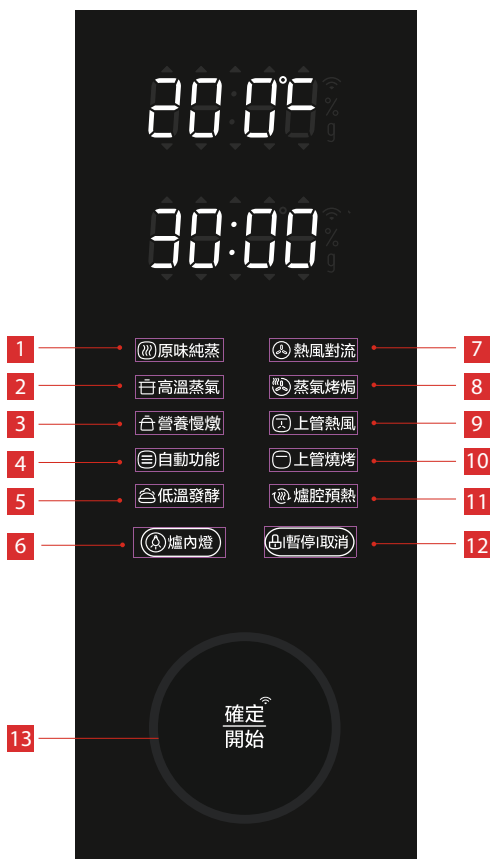

1. 原味純蒸
2. 高溫蒸氣
3. 營養慢燉
4. 自動功能
5. 低溫發酵
6. 爐內燈
7. 熱風對流
8. 蒸氣烤焗
9. 上管熱風
10. 上管燒烤
11. 爐腔預熱
12. 暫停 / 取消
13. 確定 / 開始/WIFI

功能總表

功能	預設溫度 (°C)	預設時間 (分鐘)	可調節溫度	可調節時間	描述
原味純蒸	100	15	80~100°C	1~120分鐘	模擬爐火蒸煮，火力精準 適用於肉類、蒸蛋、包點等家常菜
高溫蒸氣	130	10	100~140°C	1~60分鐘	以大火力於短時間內蒸熟食物，保留食物鮮味 適用於海鮮、蔬菜、急凍食物 在此模式下，肉眼可見的蒸氣量較少
營養慢燉	100	30	35~100°C	1分鐘-5小時	以溫和火力燉煮食物 適用於燉品、慢煮
熱風對流	180	30	100~230°C	1~120分鐘	火力均勻，金黃香脆 爐內背部設有風扇，使熱力均勻散布整個爐腔，烤燜出色澤金黃的食物 適用於烘焗肉類、炸物、烘焙蛋糕、麵包等
蒸氣烤焗	190	30	100~230°C	1~120分鐘	減油減鹽，外脆內軟 在熱風對流過程中加入蒸氣烹調，為食物提供水分 令食物快速烤熟且鎖住內部水分，保留原始鮮味 適用於烤焗蔬菜、麵包蛋糕、肉類
上管熱風	180	30	100~230°C	1~120分鐘	上方的發熱管及和上方風扇會同時運作。 熱力均勻包裹食物，加速烹調，創造酥脆口感。 適用於外脆內嫩的肉類燒烤。
上管燒烤	180	30	100~200°C	1~120分鐘	上方發熱管單獨發熱，適合燒烤食物。 適用於燒烤的最後階段，令食物更金黃鬆脆
低溫發酵	35	40	30~45°C	1分鐘-12小時	穩定的低溫發酵溫度 適用於低溫發酵麪糰、乳酪等。

注意 功能溫度每5°C進行微調。

1. 烹調功能—原味純蒸

*要使用此模式，水箱需要注滿水。

- 1** 待機時，向右旋轉旋鈕，選擇烹調模式。
共有8種模式可供選擇。
- 2** 選擇「原味純蒸」時，「原味純蒸」會亮起。
- 3** 按「確定 / 開始」以確認烹調模式。
- 4** 轉動旋鈕，設置溫度至「80-100° C」之間。
默認溫度為 100° C。
- 5** 按「確定 / 開始」進行確認。
- 6** 旋轉旋鈕，設置時間至「1-120 分鐘」之間。
默認時間為 15 分鐘。
- 7** 按「確定 / 開始」開始烹調。

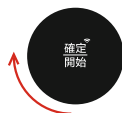
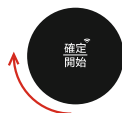

2. 烹調功能—高溫蒸氣

*要使用此模式，水箱需要注滿水。

1 待機時，向右旋轉旋鈕，選擇烹調模式。
共有8種模式可供選擇。

2 選擇「高溫蒸氣」時，「高溫蒸氣」會亮起。

3 按「確定 / 開始」以確認烹調模式。

4 轉動旋鈕，設置溫度至「100–140° C」之間。
默認溫度為 130° C。

5 按「確定 / 開始」進行確認。

6 轉動旋鈕，設置時間至「1–60 分鐘」之間。
默認時間為 10 分鐘。

7 按「確定 / 開始」開始烹調。

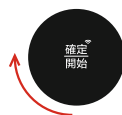

白高溫蒸氣

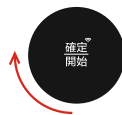
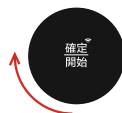

3.烹調功能—營養慢燉

*要使用此模式，水箱需要注滿水。

1 待機時，向右旋轉旋鈕，選擇烹調模式。
共有8種模式可供選擇。

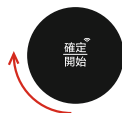

2 選擇「營養慢燉」時，「營養慢燉」會亮起。



3 按「確定 / 開始」以確認烹調模式。



4 轉動旋鈕，設置溫度至「35-100° C」之間。
默認溫度為 100° C。

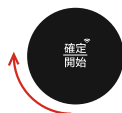

5 按「確定 / 開始」進行確認。



6 轉動旋鈕，設置時間至「1分鐘~5小時」
之間。默認時間為 30 分鐘。

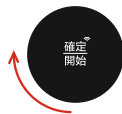

7 按「確定 / 開始」開始烹調。



4.烹調功能—熱風對流

1 待機時，向右旋轉旋鈕，選擇烹調模式。
共有8種模式可供選擇。

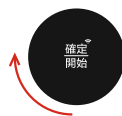

2 選擇「熱風對流」時，「熱風對流」會亮起。



3 按「確定 / 開始」以確認烹調模式。



4 轉動旋鈕，設置溫度至「100–230° C」之間。
默認溫度為 180° C。



5 按「確定 / 開始」進行確認。



6 轉動旋鈕，設置時間至「1–120 分鐘」之間。
默認時間為 30 分鐘。



7 按「確定 / 開始」開始烹調。



5. 烹調功能-蒸氣烤焗

*要使用此模式，水箱需要注滿水。

1 待機時，向右旋轉旋鈕，選擇烹調模式。
共有8種模式可供選擇。

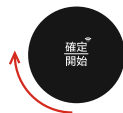

2 選擇「蒸氣烤焗」時，「蒸氣烤焗」會亮起。



3 按「確定 / 開始」以確認烹調模式。



4 轉動旋鈕，設置溫度至「100-230° C」之間。
默認溫度為 190° C。



5 按「確定 / 開始」進行確認。



6 轉動旋鈕，設置時間至「1-120 分鐘」之間。
默認時間為 30 分鐘。

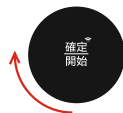

7 按「確定 / 開始」開始烹調。



6. 烹調功能-上管熱風

1 待機時，向右旋轉旋鈕，選擇烹調模式。
共有8種模式可供選擇。

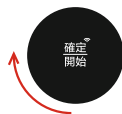

2 選擇「上管熱風」時，「上管熱風」會亮起。



3 按「確定 / 開始」以確認烹調模式。



4 轉動旋鈕，設置溫度至「100-230° C」之間。
默認溫度為 180° C。

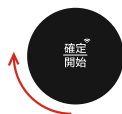

5 按「確定 / 開始」進行確認。



6 轉動旋鈕，設置時間至「1-120 分鐘」之間。
默認時間為 30 分鐘。

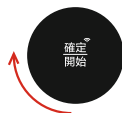

7 按「確定 / 開始」開始烹調。



7. 烹飪功能 – 上管燒烤

- 1** 待機時，向右旋轉旋鈕，選擇烹調模式。
共有8種模式可供選擇。

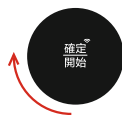

- 2** 選擇「上管燒烤」時，「上管燒烤」會亮起。

☐ 上管燒烤

- 3** 按「確定 / 開始」以確認烹調模式。



- 4** 轉動旋鈕，設置溫度至「100-200° C」之間。
默認溫度為 180° C。

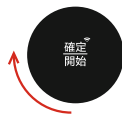

- 5** 按「確定 / 開始」進行確認。



- 6** 轉動旋鈕，設置時間至「1-120 分鐘」
之間。默認時間為 30 分鐘。



- 7** 按「確定 / 開始」開始烹調。



8. 烹調功能—低溫發酵

*要使用此模式，水箱需要注滿水。

1 待機時，向右旋轉旋鈕，選擇烹調模式。
共有8種模式可供選擇。



2 選擇「低溫發酵」時，「低溫發酵」會亮起。



3 按「確定 / 開始」以確認烹調模式。



4 轉動旋鈕，設置溫度至「30-45° C」之間。
默認溫度為 35° C。

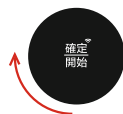

5 按「確定 / 開始」進行確認。



6 轉動旋鈕，設置時間至「1分鐘~12小時」之間。
默認時間為 40 分鐘。

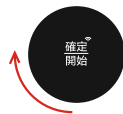

7 按「確定 / 開始」開始烹調。



9. 爐腔預熱功能

- 1 待機時，向右旋轉旋鈕，選擇「爐腔預熱」模式，「爐腔預熱」會閃爍。



爐腔預熱

- 2 按「確定 / 開始」進行確認。



- 3 轉動旋鈕，設置溫度至「100-230° C」之間。默認溫度為 180° C。



- 4 按「確定 / 開始」開始爐腔預熱



- 5 蜂鳴器響三聲表示爐腔預熱結束。打開並關閉烤箱門時，「熱風對流」功能閃爍。同時，螢幕會顯示另外兩個功能和默認時間「30:00」。

熱風對流

蒸氣烤焗

上管熱風

- 6 轉動旋鈕以選擇烹飪模式：「熱風對流」、「蒸氣烤焗」和「上管熱風」。



- 7 按「確定 / 開始」進行確認



- 8 轉動旋鈕設置溫度。按「確定 / 開始」進行確認。

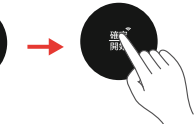

- 9 轉動旋鈕設置時間。



- 10 按「確定 / 開始」開始烹調。



注意

- 30 分鐘內未達到爐腔預熱溫度時，蜂鳴器會鳴響三聲，強制爐腔預熱完成，進入保溫階段。
- 在保溫階段，如果使用者 60 分鐘內沒有打開爐門，焗爐會在一聲蜂鳴後返回待機狀態。在等待的 60 分鐘過程中，蜂鳴器每 15 秒會響 3 次。

10.自動功能 (02-03,05-07,09-17,24,33-36) — 需預熱

1 待機時，向右旋轉旋鈕，選擇「自動功能」模式，「自動功能」會閃爍。

自動功能

2 按「確定 / 開始」進行確認。



3 轉動旋鈕，選擇所需功能。（例如自動功能 02）



4 按「確定 / 開始」進行確認。



5 可旋轉旋鈕，修改該自動功能的烹調時間。
（可以跳過這一步）

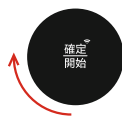

6 按「確定 / 開始」開始預熱，「自動功能」及「爐腔預熱」燈亦會同時亮起。



7 預熱完成後，「爐腔預熱」燈將閃爍提示預熱完成，將食物放在爐內，然後按「確定 / 開始」開始烹調。



10.自動功能(01,04,08,18-23,25-32) — 無需預熱

1 待機時，向右旋轉旋鈕，選擇「自動功能」模式，「自動功能」會閃爍。

☰自動功能

2 按「確定 / 開始」進行確認。



3 轉動旋鈕，選擇所需功能。（例如自動功能 01）

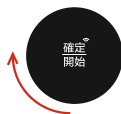

4 按「確定 / 開始」進行確認。



5 可旋轉旋鈕，修改該自動功能的烹調時間。
（可以跳過這一步）

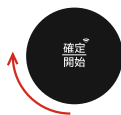

6 按「確定 / 開始」開始烹飪。



注意

- 當自動功能需要預熱，「🕒爐腔預熱」將會亮起，並在預熱完成後，閃爍提示。
- 「自動功能37-40」按「確定 / 開始」後將直接開始清潔。

10.自動功能 (37-40) – 清潔

1 待機時，向右旋轉旋鈕，選擇「自動功能」模式，「自動功能」會閃爍。

☰自動功能

2 按「確定 / 開始」進行確認。



3 轉動旋鈕，選擇所需功能。（例如自動功能 37）



4 按「確定 / 開始」進行清潔。



● 餐具消毒（自動功能 37）

此功能適用於消毒各類餐具（耐熱 100° C 以上）。

* 使用餐具清洗功能時，請確保餐具的耐熱溫度高於 100° C，且水箱內充滿水。

清潔時間

30 分鐘

● 爐腔清潔（自動功能 38）

在烹飪後，適合以蒸氣和熱力清潔爐腔。機器會噴出蒸氣來軟化污漬，使污漬更容易擦去。

* 使用爐腔清潔功能時，請確認水箱內已注滿水。

清潔時間

10 分鐘

● 爐腔除味（自動功能 39）

烹飪結束和進行自動功能38後，抹淨爐腔，然後選擇此功能，利用爐內風扇清除爐腔餘味。

清潔時間

5 分鐘

● 蒸氣系統清潔（自動功能 40）

第 1 步「PP1」（用檸檬酸）清潔（55 分鐘）

1.將10g檸檬酸倒入500ml的水中；攪拌使檸檬酸融化，然後倒入水箱。

2.選擇自動功能 40 蒸氣系統清潔，按「☰」開始蒸氣系統清潔。

第 2 步「PP2」（水）清潔（5 分鐘）

3.當清潔時間剩餘 5 分鐘時，程式將暫停，螢幕顯示"PP2"及 "5:00"。請將水箱中的含檸檬酸的水倒掉，換上清水。

* 除檸檬酸，請問放入其他物質，如清潔劑

4.將水箱放回爐，按"確定/開始"開始，蒸氣系統清潔功能將繼續直至清潔時間結束。

清潔時間

60 分鐘

10.自動功能設置表

功能	功能名稱	數量/重量	預熱	預設溫度	預設時間	可調節時間	放置位置	使用功能
A01	香草烤雞	1100g	/	220°C	41 分鐘	33-49 分鐘	下層	熱風對流X 蒸氣烤焗
A02	法式小羊架	820g	V	200°C	35 分鐘	28-41 分鐘	中層	蒸氣烤焗
A03	脆皮叉燒	450g	V	170°C+190°C	45 分鐘	36-54 分鐘	中層	蒸氣烤焗
A04	德國鹹豬手	1300g	/	100°C+130°C+ 200°C+200°C	146 分鐘	117-175 分鐘	下層	原味純蒸X 熱風對流X 蒸氣烤焗
A05	黑椒牛排	500g	V	230°C	10 分鐘	8-12 分鐘	上層	熱風對流
A06	芝士焗龍蝦	650g	V	200°C	17 分鐘	14-20 分鐘	中層	熱風對流X 上管燒烤
A07	芝士焗扇貝	8	V	230°C	9 分鐘	7-11 分鐘	上層	熱風對流
A08	醬燒豬肋骨	500g	/	170°C	36 分鐘	29-43 分鐘	中層	蒸氣烤焗
A09	香烤鱈魚	220g	V	230°C	9 分鐘	7-11 分鐘	上層	熱風對流
A10	黑椒蜜糖雞翼	450g	V	220°C	17.5 分鐘	14-21 分鐘	中層	蒸氣烤焗
A11	蒜香蝦肉串	600g	V	230°C	10 分鐘	8-12 分鐘	上層	熱風對流
A12	蒜香烤蝦	250g	V	230°C	7 分鐘	6-8 分鐘	上層	熱風對流
A13	蘆筍煙肉卷	300g	V	230°C	8 分鐘	7-9 分鐘	中層	蒸氣烤焗
A14	沙嗲雞肉串	1000g	V	230°C	17 分鐘	14-20 分鐘	上層	熱風對流
A15	蔬菜雞肉卷	550g	V	210°C	28 分鐘	22-34 分鐘	中層	熱風對流
A16	咖哩雞肉串	200g	V	230°C	15 分鐘	12-18 分鐘	中層	蒸氣烤焗
A17	海鮮薄餅	600g	V	200°C	24 分鐘	19-29 分鐘	中層	熱風對流
A18	栗子蒸雞	800g	/	100°C	30 分鐘	24-36 分鐘	中層	原味純蒸
A19	孔雀開屏魚	500g	/	100°C	18 分鐘	15-21 分鐘	中層	原味純蒸
A20	梅菜扣肉	1000g	/	100°C	60 分鐘	48-72 分鐘	下層	原味純蒸
A21	清蒸龍脷柳	500g	/	100°C	18 分鐘	15-21 分鐘	中層	原味純蒸
A22	花蟹蒸蛋	300g	/	100°C	10 分鐘	8-12 分鐘	中層	原味純蒸
A23	南瓜蒸排骨	600g	/	100°C	18 分鐘	15-21 分鐘	中層	原味純蒸
A24	鮮味蘆筍	300g	V	230°C	9 分鐘	7-11 分鐘	中層	蒸氣烤焗
A25	松茸燉羊排	2000g	/	100°C	90 分鐘	72-108 分鐘	下層	原味純蒸
A26	清蒸石斑魚	490g	/	120°C	15 分鐘	12-18 分鐘	中層	高溫蒸氣

10.自動功能設置表

功能	功能名稱	數量/重量	預熱	預設溫度	預設時間	可調節時間	放置位置	使用功能
A27	白菜豬肉蒸餃	500g	/	100°C	20 分鐘	16-24 分鐘	中層	原味純蒸
A28	香菇鮮肉包	12	/	100°C	25 分鐘	20-30 分鐘	中層	原味純蒸
A29	蒸沙薑雞	900g	/	110°C	40 分鐘	32-48 分鐘	下層	高溫蒸氣
A30	冰糖燉雪梨	2000g	/	100°C	60 分鐘	48-72 分鐘	下層	原味純蒸
A31	紅棗薑汁糕	1200g	/	100°C	45 分鐘	36-54 分鐘	下層	原味純蒸
A32	艾草茶糰	12	/	100°C	12.5 分鐘	10-15 分鐘	中層	原味純蒸
A33	杏仁瓦片	325g	V	150°C	24 分鐘	19-29 分鐘	中層	熱風對流
A34	蔓越莓餅乾	450g	V	160°C	23 分鐘	18-28 分鐘	中層	熱風對流
A35	裸麥麵包	500g	V	210°C	21 分鐘	17-27 分鐘	中層	熱風對流
A36	蔓越莓麵包	400g	V	170°C	25 分鐘	21-29 分鐘	中層	熱風對流
A37	餐具消毒	/	/	100°C	30 分鐘	/	/	/
A38	爐腔清潔	/	/	/	10 分鐘	/	/	/
A39	爐腔除味	/	/	/	5 分鐘	/	/	/
A40	蒸氣系統清潔	/	/	/	60 分鐘	/	/	/

爐內燈



在待機或烹飪過程中，您可以輕觸「爐內燈」打開 / 關閉爐燈，以便您隨時觀察焗爐中的食物。

兒童鎖功能

您可以使用此功能以防止兒童意外開啟烹調模式。

- 1** 開：在待機狀態，按住「暫停 / 取消」三秒鐘。
蒸氣焗爐會發出一聲嗶，然後顯示 。



- 2** 關：在待機狀態下，按住「暫停 / 取消」三秒鐘。
蒸氣焗爐會發出一聲嗶聲，鎖定的圖標  會消失。



指示燈及其他功能提示

焗爐過熱 如果出現“F01”，則表示爐腔溫度高於可用溫度範圍。產品冷卻後方可使用產品。

缺水 如果出現“F02”和聽見五聲叮聲，則表示水箱缺水或未安裝到正確位置。請將加水至水箱的「MAX」線，然後將水箱重新裝入焗爐，繼續烹飪過程。

待機模式 在待機模式下，焗爐被閒置 5 分鐘，整個面板關閉。要將焗爐重啟到待機模式，旋轉旋鈕「」，按任意功能，或打開烤箱門。

選擇過程 在選擇功能過程中，焗爐被閒置 5 分鐘，選擇過程將自動取消。

其他重要提示



- 在烘烤食物時，請在烤盤上鋪上錫紙，然後將食物放在上面。請不要直接用醋、檸檬、果汁等酸性物質污染烤盤。
- 使用原味純蒸功能後，建議打開爐門，有助去除積水。
- 爐門封條設計可拆卸。如果水滴或食物殘渣卡在爐門封條上，請小心取下封條，擰乾水分後用軟布擦拭，擦拭乾淨，然後放回原處。
- 蒸氣可能從爐門四周縫隙處溢出。使用與蒸氣相關的功能時，產品運轉過程中爐腔內會產生大量蒸氣，部分蒸氣可能從門縫四周漏出，這是正常現象。

警告

- 1** 請勿太用力刮擦封條，可否則蒸氣很容易漏出。
- 2** 請小心安裝 / 拆卸封條；否則蒸氣可能會洩漏。
- 3** 使用烤箱前，請務必安裝封條。



疑難解答

使用下表檢查問題，並嘗試針對每個問題解決。

問題	可能的原因	可能的補救措施
烤箱無法啟動	<ul style="list-style-type: none"> a. 沒有插緊電源。 b. 爐門未關。 c. 錯誤操作。 	<ul style="list-style-type: none"> a. 重新插入插座。 b. 關閉爐門重試。 c. 檢查說明
電弧或火花	<ul style="list-style-type: none"> a. 使用了不適用於蒸氣的用具。 b. 蒸氣空著運作。 c. 濺出的食物殘留爐腔。 	<ul style="list-style-type: none"> a. 僅使用適用於蒸氣的用具。 b. 不要空著運作蒸氣。 c. 用濕毛巾清潔爐腔。
煮得不均勻的食物	<ul style="list-style-type: none"> a. 使用了不適用於蒸氣的用具。 b. 食物沒有完全解凍。 c. 烹飪時間、功率不合適。 d. 食物沒有被旋轉或攪拌。 	<ul style="list-style-type: none"> a. 僅使用適用於蒸氣的用具。 b. 徹底解凍食物。 c. 使用正確的烹飪時間和功率。 d. 旋轉或攪拌食物。
煮過頭的食物	烹飪時間、功率不合適。	使用正確的烹飪時間和功率。
未煮熟的食物	<ul style="list-style-type: none"> a. 使用了不適用於蒸氣的用具。 b. 食物沒有完全解凍。 c. 通風口阻塞。 d. 烹飪時間、功率不合適。 	<ul style="list-style-type: none"> a. 僅使用適用於蒸氣的用具。 b. 徹底解凍食物。 c. 檢查以確保通風口不受阻塞。 d. 使用正確的烹飪時間、功率
解凍不當	<ul style="list-style-type: none"> a. 使用了不適用於蒸氣的用具。 b. 烹飪時間、功率不合適。 c. 食物沒有被旋轉或攪拌。 	<ul style="list-style-type: none"> a. 僅使用適用於蒸氣的用具。 b. 使用正確的烹飪時間和功率。 c. 旋轉或攪拌食物
傳感器烹調的食物未被正確煮熟	<ul style="list-style-type: none"> a. 覆蓋未通風的食物。 b. 在螢幕顯示傳感器檢測到的烹飪時間之前，爐門已打開。 	<ul style="list-style-type: none"> a. 食物的覆蓋物必須有用於排出蒸氣的通風孔。 b. 在螢幕顯示傳感器檢測到的烹飪時間之前，請勿打開爐門攪拌或旋轉食物。

規格

容量	30L	上管燒烤	1500-1600W
額定電壓 / 頻率	220-230V~50Hz	蒸氣烤焗	1550-1700W
熱風對流功率	1550-1700W	外形尺寸 (闊 x 深 x 高)	472x465x375 mm
原味純蒸功率	1500-1600W	爐腔尺寸 (闊 x 深 x 高)	410x325x230 mm

- 1** 產品尺寸為闊 × 深 × 高，總深度包括把手長度和背板拉展長度，高度數值包括爐腳。
- 2** 爐腔尺寸包括拉展長度，爐腔體積為寬度、深度和高度相乘。由於產品不斷升級，體積參數與標註的數據可能存在偏差，偏差範圍為 ± 12%。
- 3** 由於我們的產品在不斷改進，實際參數可能與標註的有所不同。具體請參考實際參數。

產品影片



#DetailsMatter

USER MANUAL

SMART CONTROL STEAM OVEN

MS5-STR30SC(BK)

Please review this instruction manual before operating.

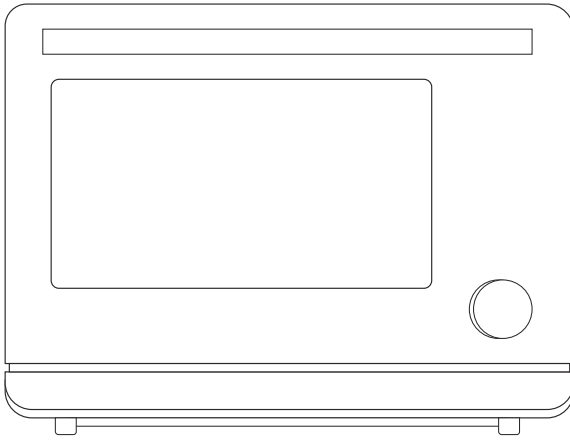

TOSHIBA

CONTENTS

IOT SMART CONTROL

PRODUCT WIRELESS NETWORK CONNECTION	EN-4
QUICK START GUIDE	EN-5
TSmartlife OPERATION	EN-8
HOW TO USE ONLINE RECIPES?	EN-10

PRODUCT SAFETY

PRECAUTIONS	EN-11
IMPORTANT SAFETY INSTRUCTIONS WARNING	EN-12

PRODUCT INTRODUCTION

SETTING UP YOUR OVEN	EN-17
IMPORTANT INFORMATION ABOUT INSTALLING	EN-18
ATTENTION IN PLACEMENT	EN-19
INITIAL USE	EN-21

CLEANING AND CARE

WATER BOX USE	EN-23
BEFORE USING	EN-24
CLEANING AND MAINTENANCE PRECAUTIONS	EN-25

INSTRUCTION FOR USE

OPERATION INSTRUCTIONS	EN-28
MENU SUMMARY CHART	EN-29
1.COOKING FUNCTION-STEAM	EN-30
2.COOKING FUNCTION-HIGH TEMP. STEAM	EN-31
3.COOKING FUNCTION-STEW	EN-32
4.COOKING FUNCTION-CONVECTION	EN-33
5.COOKING FUNCTION-COMBI	EN-34
6.COOKING FUNCTION-CONVECTION GRILL	EN-35
7.COOKING FUNCTION-GRILL.....	EN-36
8.COOKING FUNCTION-FERMENTATION	EN-37
9.PREHEAT FUNCTION	EN-38
10.AUTO MENU (02-03,05-07,09-17,24,33-36)– PREHEAT.....	EN-40
10.AUTO MENU(01,04,08,18-23,25-32)– NO PREHEAT	EN-41
10.AUTO MENU(37-40)-CLEANING	EN-42
10.AUTO MENU SETTING	EN-43
OVEN LIGHT	EN-45
CHILDREN LOCK FUNCTION	EN-45
SIGNAL INDICATION	EN-46
OTHER IMPORTANT TIPS	EN-47



MAINTENANCE

TROUBLESHOOTING	EN-48
PRODUCT PARAMETERS	EN-49

IOT SMART CONTROL

PRODUCT WIRELESS NETWORK CONNECTION

1 Connect the network

Press and hold "  " 確定/開始 (Start/Confirm) for 3 seconds, till a beep sounds, "AP" and flashing "  " show on display. If it fails, "N0~N5" will display, and the oven will return to standby after 30 seconds.



2 Disconnect from the network

Press and hold "  " for 8 seconds, till a beep sounds, "--" flashes for few seconds, if the link has been removed successfully, the screen will display "8888" and then return to standby after 3 seconds. If it fails, "FFFF" will display, and the oven will return to standby after 3 seconds.



- NOTE: Only 1 main account allowed to control the device and invite other family accounts to use at current stage.

QUICK START GUIDE

CONNECT YOUR DEVICE TO YOUR MOBILE PHONE WITH TSmartLife App

1 DOWNLOAD THE TSmartLife App

Scan QR code or find us on your App store

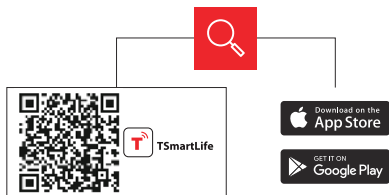

2 REGISTER AND LOG IN

Log in for existing users or sign up for new users

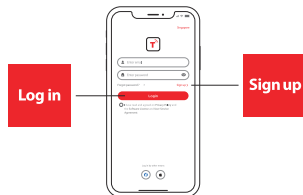

3 CONNECT YOUR DEVICES TO TSmartLife

STEP 1.

Connect to wireless network and enable Bluetooth.

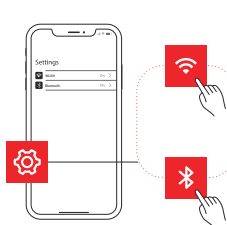

STEP 2.

Open the TSmartLife App. Power on selected device.

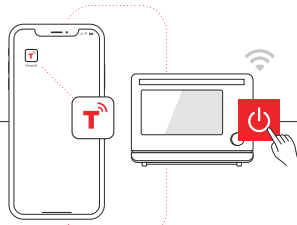

STEP 3.

Add your device using one of the following methods:

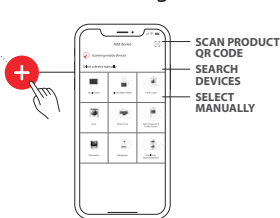

STEP 4.

Ensure device and App are under same wireless network.

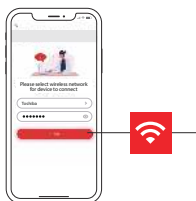

STEP 5.

Press "Wi-Fi" button for 3 seconds on the panel. Following instruction to set up, it will connect automatically.

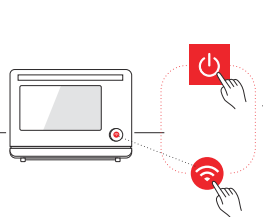

STEP 6.

Rename your device and try to remote control it.

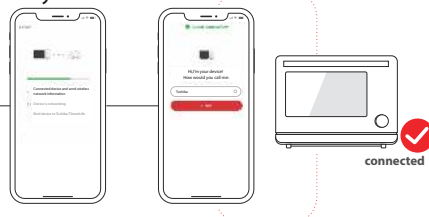



HOW CONNECT YOUR DEVICES TO TSmartLife







TIPS

- Make sure your devices are powered on.
- Keep your mobile phone close to your device during connection.
- Connect your mobile phone to the wireless network at home.
- Enable the 2.4GHz frequency on your wireless network router. Contact the manufacturer if unsure whether the router supports 2.4GHz.
- The device is unable to connect to wireless network that requires authentication and also appears in public areas such as hotels and restaurants.
- It is recommended to use a wireless network name that only contains letters and numbers. If your wireless network name contains special characters, modify it in the router. Disable WLAN+ (Android) or WLAN Assistant (iOS) when connecting your devices to the network.
- To reconnect a device to the wireless network, click "+" on the App home screen and add the device again by the category and model according to the App prompts.

TSmartLife APP TROUBLESHOOTING



Background :

Offering dual-band support provides choices and maximum flexibility of the product to have successful experience on home network. Home networks can be expected to have multiple  service possibilities, depending on how their router is configured. There are four  router configuration modes: A, B, C and D.

- A. 2.4GHz only ... e.g. older model  router
 - o In this case dual band radio will automatically operate at 2.4GHz
- B. 5GHz only ... some people may choose to turn off older 2.4GHz band due to conflicting interference
 - o In this case dual band radio will automatically operate at 5GHz
- C. 2.4GHz and 5GHz sharing same SSID name ... e.g. Johns 
 - o In this case the  router and dual-band radio will negotiate the best frequency to use
- D. 2.4GHz and 5GHz with different SSID names ... e.g. Johns _2G and Johns _5G
 - o In only this case is there a choice which  band to use.

Having a dual band radio in the appliance means it is not necessary to change routers or router configuration unless problems are experienced, in which case knowing what  router configuration you have (see above A, B, C or D) is important to know and understand.

If unable to join network at the first time

- Cannot see home SSID network :
 - o Weak signal ... Since appliance radio is dual-band this means neither 2.4GHz nor 5GHz signal is being received by the appliance. Just because the  signal can be seen by the phone doesn't necessarily mean that the appliance radio can see it if the signal is marginal. Long distance between router and appliance or encountering too many barriers can reduce the signal level too much. Reorienting the router may improve the situation slightly. A better solution would be a  repeater or a higher quality router. Recognize that all  routers transmit power is limited by federal regulations, but a higher quality router can do a better job of transmitting the signal equally in all directions, have more sensitive receivers to better handle weak signals, and have higher quality software to minimize the dropping of connections.
- SSID network seen but cannot join:
 - o Networks requiring authentication ... often used with public networks at restaurants or hotels. Products cannot accept the legal agreement required to join the network. Please switch to a network that does not require authentication.
 - o Insufficient encryption ... for cybersecurity reasons Toshiba does not recommend products to join non-encrypted or insufficiently encrypted networks (e.g. WEP encryption).
 - o Password length ... for cybersecurity reasons Toshiba recommends networks to have strong passwords, but the maximum password length supported is 32 characters.
 - o Incorrect password ... If trying to join a different network than the one the phone is currently using, then it is always possible that the network password in the phone is no longer correct. In this case, new credentials will need to be provided.
 - o Illegal SSID name ... TSmartLife App accepts any SSID name, but the App may issue warning when attempting to join network with certain non-alphanumeric or foreign language characters.
- WLAN+ (Android) or WLAN Assistant (iOS) functions are turned on, please turn off and reconnect to the Internet.

If can join network but the connection is unstable

For  configuration modes A, B and C, follow the instructions provided by your router manufacturer to make the indicated router configuration changes :

- In case of router configuration A (see above), Toshiba recommends enabling 5GHz band if it is disabled in your router and choosing a distinct SSID name for the 5GHz band (e.g. SSIDname_5G). Then follow the normal joining instructions to join the 5GHz network. If your router is an older 2.4GHz only router, Toshiba recommends upgrading to a newer dual-band router.
- In case of router configuration B (see above), Toshiba recommends enabling 2.4GHz band (all routers that offer 5GHz also support 2.4GHz), and choose a distinct SSID name for the 2.4GHz band (e.g. SSIDname_2G). Then follow the normal joining instructions to join the 2.4GHz network.
- In case of router configuration C (see above), Toshiba recommends assigning distinct SSID names for the 2.4GHz and 5GHz bands. Then follow the normal joining instructions to one of the networks, and subsequently follow the troubleshooting instructions for  mode D.

For these steps router configuration changes are not required:

- In case of router configuration D (see above), then it is worthwhile to try operation on the other band before making changes to the router configuration or upgrading the router. In other words, if unstable connection using 2.4GHz then try 5GHz instead. Or if unstable connection using 5GHz then try 2.4GHz instead. Follow the instructions below "How to set the network to 2.4GHz or 5GHz."
- WLAN+ (Android) or WLAN Assistant (IOS) functions are turned on, please turn off and reconnect to the Internet.

If your Device offline, check your connection status Please confirm that

- Whether the device is properly powered.
- Whether the network signal is stable.
- Whether the  name or password has been changed, if so, please add the device again.

TSmartlife OPERATION

INTERFACE INTRODUCTION



Child Lock



Pure Steam



High-temp. steam



Slow Steam



Fermentation



Convection Bake



Steam-assisted Bake



Preheat



Grill



Convection Grill

TSmartlife OPERATION

How to start cooking

- 1 Select Cooking Program
- 2 Click temperature
- 3 Select temperature



- 4 Select time



- 5 Press "start" button on the phone



- 6 Press "Confirm/Start" button on the device



HOW TO USE ONLINE RECIPES?

1 Select "Recipes"



2 Select one recipe you prefer

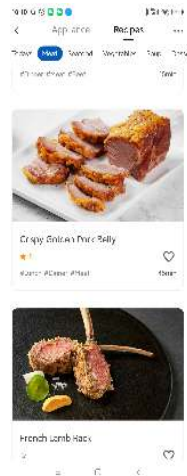

3 Check recipe details or start cooking by press "one-click start"

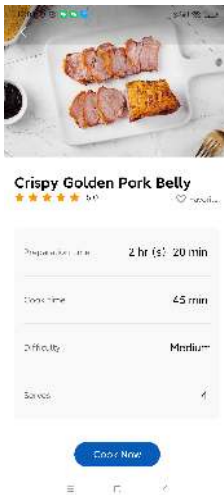

4 Press "Start/Confirm" button on the device



PRECAUTIONS

- 1** Do not attempt to operate this oven with the door open. It is important not to break or tamper with the safety interlocks.
- 2** Do not place any object between the oven front face and the door or allow soil or cleaner residue to accumulate on sealing surfaces.

ADDENDUM

If the apparatus is not maintained in a good state of cleanliness, its surface could be degraded and affect the lifespan of the apparatus and lead to a dangerous situation.

IMPORTANT SAFETY INSTRUCTIONS WARNING



To reduce the risk of fire, electric shock, injury to persons when using your appliance, follow basic precautions, including the following:

- Read and follow the specific: "PRECAUTIONS".
- This appliance can be used by children aged from 8 years and above and persons with reduced physical, sensory or mental capabilities or lack of experience and knowledge if they have been given supervision or instruction concerning use of the appliance in a safe way and understand the hazards involved. Children shall not play with the appliance. Cleaning and user maintenance shall not be made by children unless they are older than 8 and supervised. Children less than 8 years of age shall be kept away unless continuously supervised.
- Keep the appliance and its cord out of reach of children less than 8 years.
- If the supply cord is damaged, it must be replaced by the manufacturer, its service agent or similarly qualified persons in order to avoid a hazard. (For appliance with type attachment)
- **WARNING:** Ensure that the appliance is switched off before replacing the lamp to avoid the possibility of electric shock.
- When heating food in plastic or paper containers, keep an eye on the oven due to the possibility of ignition.
- **WARNING:** It is hazardous for anyone other than a competent person to carry out any service or repair operation.
- Only use the temperature probe recommended for this oven. (for ovens provided with a facility to use a temperature-sensing probe.)

IMPORTANT SAFETY INSTRUCTIONS WARNING



- This appliance is intended to be used in household and similar applications such as:
 - staff kitchen areas in shops, offices and other working environments;
 - by clients in hotels, motels and other residential type environments;
 - farm houses;
 - bed and breakfast type environments.
- The appliance shall not be cleaned with a steam cleaner.
- **WARNING:** Accessible parts may become hot during use. Young children should be kept away.
- Steam cleaner is not to be used.
- Surface of a storage drawer can get hot.
- **WARNING:** The appliance and its accessible parts become hot during use. Care should be taken to avoid touching heating elements. Children less than 8 years of age shall be kept away unless continuously supervised.
- During use the appliance becomes hot. Care should be taken to avoid touching heating elements inside the oven.
- The appliance must not be installed behind a decorative door in order to avoid overheating. (This is not applicable for appliances with decorative door.)
- Care should be taken not to displace the turntable when removing containers from the appliance.
- **WARNING:** When move the oven, do not carry handle.(Oven is overweight, handles are easily broken.)
- The water in the receiving tank, inside the oven and in the water tank should be cleaned up after each use.

IMPORTANT SAFETY INSTRUCTIONS WARNING



- Do not use paper cups and plastic containers with a temperature resistance of less than 120 degrees. And use a container suitable for cooking temperature. Can use glass, ceramics, stainless steel utensils.
- Steam is the main heating function for this product.
- There may be water stains in the oven cavity before first use, which is a normal phenomenon as part of the factory test.
- The combi steamer produces a large amount of steam under steam cooking mode. Most of the steam will be vented from the frontal ventilation and some condensation water will be found around the ventilation vent.

READ CAREFULLY AND KEEP FOR FUTURE REFERENCE

TO REDUCE THE RISK OF INJURY TO PERSONS GROUNDING INSTALLATION



DANGER

Electric Shock Hazard



Touching some of the internal components can cause serious personal injury or death.

Do not disassemble this appliance.

WARNING

Electric Shock Hazard



- Improper use of the grounding can result in electric shock. Do not plug into an outlet until appliance is properly installed and grounded.
- This appliance must be grounded. In the event of an electrical short circuit, grounding reduces the risk of electric shock by providing an escape wire for the electric current. This appliance is equipped with a cord having a grounding wire with a grounding plug. The plug must be plugged into an outlet that is properly installed and grounded.
- Consult a qualified electrician or serviceman if the grounding instructions are not completely understood or if doubt exists as to whether the appliance is properly grounded. If it is necessary to use an extension cord, use only a 3-wire extension cord.

TO REDUCE THE RISK OF INJURY TO PERSONS GROUNDING INSTALLATION



- 1** A short power-supply cord is provided to reduce the risks resulting from becoming entangled in or tripping over a longer cord.
- 2** If a long cord set or extension cord is used:
 - 1) The marked electrical rating of the cord set or extension cord should be at least as great as the electrical rating of the appliance.
 - 2) The extension cord must be a grounding-type 3-wire cord.
 - 3) The long cord should be arranged so that it will not drape over the counter top or tabletop where it can be pulled on by children or tripped over unintentionally.

PRODUCT INTRODUCTION



SETTING UP YOUR OVEN

NAMES OF OVEN PARTS AND ACCESSORIES

Remove the oven and all materials from the carton and oven cavity. Your oven comes with the following accessories:

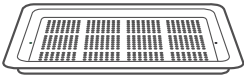

Steaming tray

(Can only be used in pure steam function)

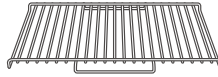

Steam rack

(For grilling, baking and steam cooking, place it on a flat plate in the cavity or use it with a baking tray; it is forbidden to use a steam rack with microwave function)

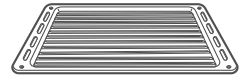

Baking tray

(Can be used in convection and combi function.)
(Please spread tinfoil on the tray when it is used.)



Instruction Manual

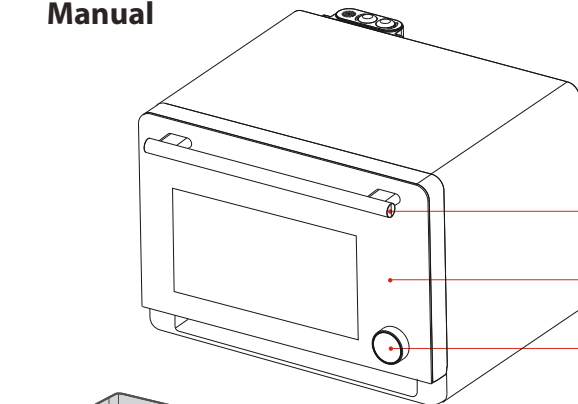

1 Handle

2 Control panel

3 knob

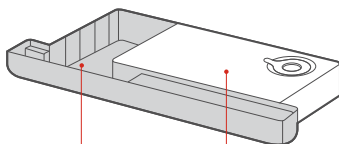

4 Water box

5 Dirty water box

IMPORTANT INFORMATION ABOUT INSTALLING



- This appliance is NOT intended for use in a commercial environment.
- Please observe the installation instructions provided and note that this appliance should only be installed by a qualified technician.
- The appliance is fitted with a plug and must only be connected to a properly installed earthed socket.
- In case a new socket is needed, installation and cable connection must only be done by a qualified electrician. If the plug is no longer accessible following installation, a pole disconnecting device must be present on the installation site with a contact gap of at least 3 mm.
- Adapters, multi-way strips and extension cords must not be used. Overloading can result in fire.
- If the appliance is not fitted with a supply cord and a plug, the connection equipment must have a contact separation in all poles that provide full disconnection, and the appliance must be incorporated in the fixed wiring in accordance with the wiring rules.



The accessible surface may be hot during operation.

ATTENTION IN PLACEMENT



In order to avoid the oil and smoke discharged from the exhaust port polluting the furniture or even causing fire due to overheating in the cooking process, the steam oven should be kept at a certain distance from walls and cabinets. Please place it at a safe distance as indicated in the figure below.

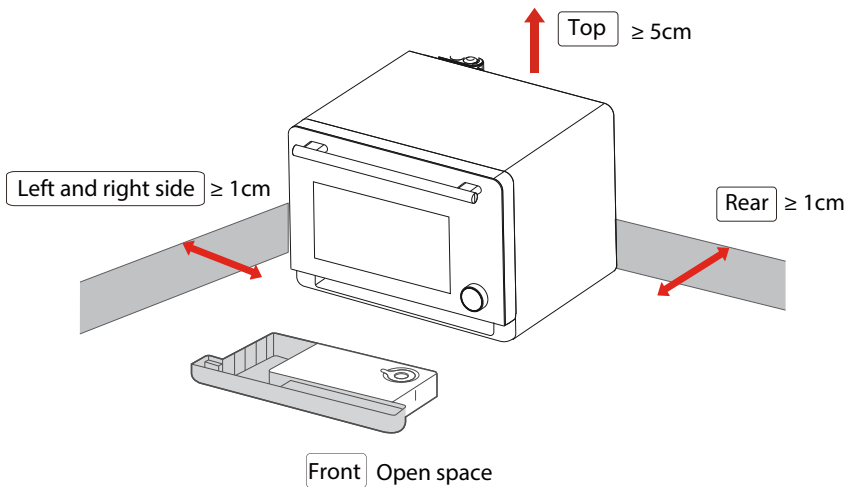

* To avoid fire hazard or explosion, do not heat or use flammable materials in or near the appliance.

- In order to avoid injury and property damage to the user, the product body and the User's Guide contain important contents, such as proper usages.
- Icons and symbols are designed to help understand and may differ from the real product.
- Please read the relevant labeling carefully before use and strictly observe it; please keep it properly for future reference.

ATTENTION IN PLACEMENT



Notes

- If there is any difference between the physical object and the following figure, the physical object shall prevail.
- Please refer to the safety distance marked in the figure to place the product.
- This product is a desktop product, and it is forbidden to be used as a built-in product.

INITIAL USE



Please read the User's Guide carefully before use and keep it properly for future reference.

It is forbidden to insert metal or foreign objects, such as wire and fingers, into the suction vent, exhaust port, and louver in the rear side of the steam oven.

Otherwise, it may cause electric shock or injury. If any foreign object is inserted into the product by accident, please unplug the power cord and contact our customer service center.

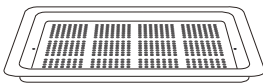
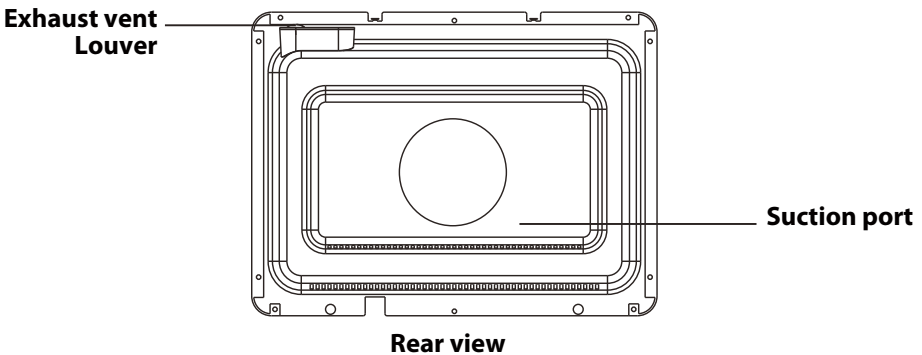

Steaming tray (Can be used in steam function)

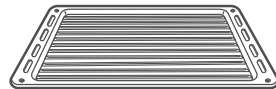

Baking tray (Can be used in convection and the combi function)

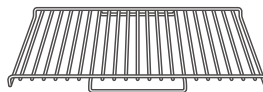

Steam rack (For grilling, baking and steam cooking, place it on a flat plate in the cavity or use it with a baking tray; it is forbidden to use a steam rack with microwave function)



INITIAL USE

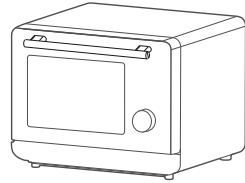

- 1 Open the door of the steam oven, take out everything, and then close the door.

***Note:** If water stains are found in the furnace, it is still normal, because the product has been tested for water first. Please wipe the water in the furnace first.



- 2 Fill up the water box, rotate the selector to select  auto function; press  to confirm. Then rotate the selector to 「38 Cavity Cleaning」



- 3 Press the  key to start cleaning, which takes about 10 minutes.

- 4 When cleaning is completed, the buzzer will sound for one times, and then please open the oven door for cooling.

Reminder :

- a. If the seal of the furnace door is found loose, press it back into the groove.
- b. Do not touch the oven chamber with your hands immediately after cleaning.
- c. Please wipe off the accumulated water in the oven chamber with a soft cloth after cooling.
- d. Do not close the oven door before the chamber is completely cooled down.

CLEANING AND CARE



WATER BOX USE

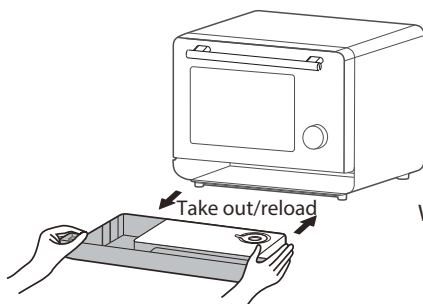

Waste water box

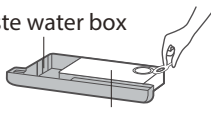

Clean water box

Uncover the rubber ring, add a proper amount of room-temperature boiled water, cover the rubbering and ensure good fitting.



Uncover the water lid to clean, or drain the remaining water.

- 1** a proper amount of room-temperature boiled water in the water box to prevent scale from affecting the service life of the machine.
- 2** After cooking, the water in the waste water box and the clean water box must be drained to avoid generating bacteria.

Please fill the water box with water in time.

When the water box is short of water, the water pump will send out a beep-like prompt to remind the user of water shortage.

Please fill the water box with water in time. If the water box is in a water shortage state all the time, the machine will stop working 5 beep sounds, and the screen will display [F02] at the same time.

Please add water to clean water box until reach "MAX" line, then reload the water box to the oven to continue cooking process.

BEFORE USING



- **First cleaning**

Remove all protective foils from the front of the steam oven. Before using, please check the "Cleaning and Care" section for more information.

- **Cleaning before using**

Before heating, wipe the inside of the steam oven with a damp cloth to remove dust accumulated during the process and residual packaging material.

There is protective coating on metal parts, which may emit a slight odor when first heated.

This odor dissipates in a short time along with vapor. This does NOT indicate any mechanical faults. Also, please make sure the kitchen is well ventilated when you first heat it up.

- **Please remove ALL accessories and clean outside the oven**

There is often odor when new appliance is first used. Please use Auto Menu No.39 for cleaning to remove odors.

CLEANING AND MAINTENANCE PRECAUTIONS



- **Oven door and enclosure**

- Wipe with a slightly damp cloth. Wipe stubborn stains firstly with mild soap and then wipe with a slightly damp cloth;
- WARNING** Do not clean with much water, or water may rust the appliance and cause damage;

- **Vapor vent**

- Wipe with a slightly damp cloth. After steam cooking, there will be white marks (dissolvable substances in the water) near the vapor vent. Carefully wipe with a wrung-out cloth;

- **Oven cavity and door (interior)**

- Wipe with a slightly damp cloth. parts with stubborn stains can be soaked in a mild soap solution for 30 minutes before wiping;
- After steam heating, wait for the steam oven to cool down, and then wipe off any condensed water with a dry cloth;
- WARNING** Do not use sharp objects, such as a wire brush or fork, as this may result in scratches or cracks;

- **Door Seal**

- If water drops or food residues get stuck in the door seal, please remove the seal with care. Wipe and clean it with a soft cloth after wringing out the water, and then install it in place;



WARNING

- 1 When cleaning, do not scrape or wipe the seal vigorously to avoid damage to the seal, or it may result in steam leakage.
- 2 Be careful when removing and installing the seal, or else it may result in steam leakage.

CLEANING AND MAINTENANCE PRECAUTIONS



- Wipe the enclosure with a cloth dampened with a soft detergent (such as detergent), then wipe it with a damp cloth, and finally wipe it with a dry cloth. Do not wipe the product with a hard object such as a wire brush. Do not clean the door safety lock system.
-**WARNING** Do not use a rough scrubbing agent or a sharp metal scraper to clean the glass of the oven door, which may cause the glass to shatter.
- Always keep the door and the body joint clean
- The grease produced during cooking can corrode the chamber and affect the heating effect, thus changing the taste of the food. Therefore, please clean the oven cavity with a damp cloth or a cloth dampened with a soft detergent when the chamber is fully cooled down.
- Clean accessories with warm water regularly. Do not clean with cold water immediately after cooking for a long time.
- Do not wipe the oven with poor cleaning agent or corrosive, volatile chemical solvent to avoid damage to the oven.

Tips and Notes

- To avoid damaging the surfaces of your appliance, do not use: cleaning agents containing soda, ammonia, acids or chlorides.
- Cleaning agents containing descaling.
- Agents abrasive cleaning agents, e.g. powder cleaners and cream cleaners, hard, abrasive sponges and brushes, e.g. pot scourers.
- Stainless steel cleaning agents.

CLEANING AND MAINTENANCE PRECAUTIONS



- Do not use coarse scrubbing agent or sharp metal scraper to clean the glass of the oven door, which may cause the glass to shatter.
- Do not put the power cord and plug directly on the outer cover, so as to prevent the residual heat of the outer cover from damaging the power cord.
- When the oven is at high temperature, the internal steam expands. Due to the air pressure, it is normal to hear an air sound if the door is closed immediately after being opened, which does not affect the use. About 10 seconds after opening the door, the oven temperature drops slightly, and there will be no sound during door closing.

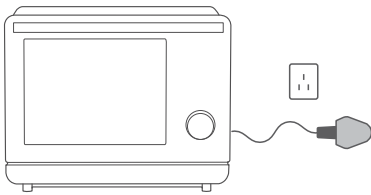

Unplug the machine and wait for the machine to cool down completely.



Wipe the product housing with a cloth moistened with soft detergent, and then wipe it with a damp cloth.

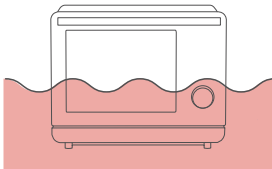

It is strictly forbidden to immerse the steam oven in water or other liquids.

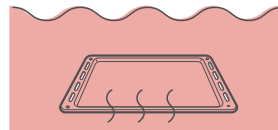

In order to achieve the best cleaning effect, it is recommended to clean accessories with warm water.

INSTRUCTION FOR USE





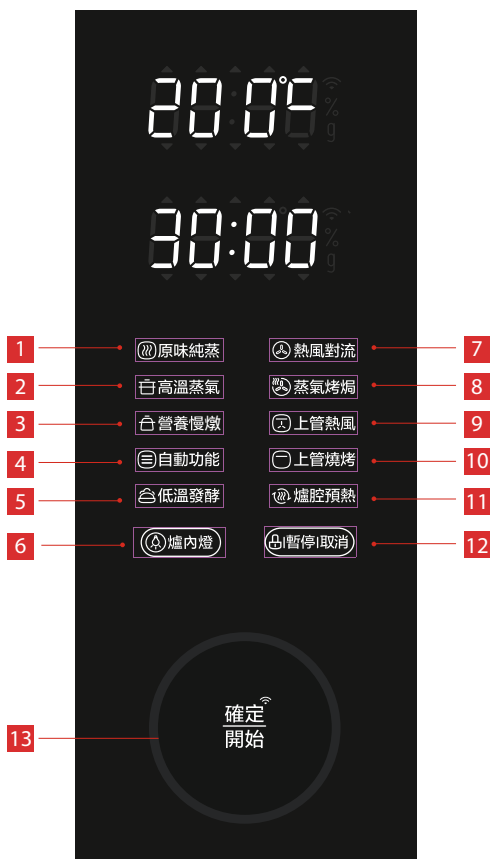



OPERATION INSTRUCTIONS

CONTROL PANEL



- 1.Steam
- 2.High Temp. Steam
- 3.Stew
- 4.Auto Menu
- 5.Fermentation
- 6.Oven Light
- 7.Convection
- 8.Combi.
- 9.Convection Grill
- 10.Grill
- 11.Preheat
- 12.Pause/Cancel
- 13.Start/Confirm

MENU SUMMARY CHART

Menu	Default Temperature (°C)	Default Time(min)	Temperature Range	Time Range	Description
Steam 	100	15	80~100°C	1~120mins	Simulated fire cooking, accurate heat power Suitable for home cooking food such as meat, steamed eggs and buns
High Temp. Steam 	130	10	100~140°C	1~60mins	Steaming the food in a short time with high heat power to keep the delicious taste of the food Suitable for home cooking food such as seafood, vegetables and quick-frozen food In this mode, less steam is visible to eyes
Stew 	100	30	35~100°C	1min-5hrs	Simmering food with moderate heat power Suitable for stews and slowly-cooked food
Convention 	180	30	100~230°C	1~120min	Evenly distributed heat power, cooking crispy food with golden color There is a fan at the back of the oven to evenly spread the heat throughout the cavity. Giving your baked food a golden color. Suitable for baked meat, fried food, baked cake, bread, etc.
Combi. 	190	30	100~230°C	1~120min	Reduced oil and salt, crisp outside and soft inside Steam is added to cook in the process of hot air convection, which provides water for food to be cooked quickly, locks the internal water and retains the original flavor. Suitable for baked vegetables, bread, cakes and meat
Convention Grill 	180	30	100~230°C	1~120min	In this mode, the upper heating element and the hot air fan on the back work at the same time. The heat wraps the food in all directions, speeding up the cooking time and creating a crispy effect. This mode is suitable for grilling meat that needs a crispy exterior and a juicy interior.
Grill 	180	30	100~200°C	1~120min	The upper heating tube separately generates heat, which is suitable for grilling food. The goldenness and crispness of the food can be enhanced in the final stage of grilling.
Fermentation 	35	40	30~45°C	1min-12hrs	Stable fermentation temperature, temperature range: 30-45°C Suitable for fermented dough, yogurt, etc.

NOTE

• The step quantities for the temperature of the coding switch is 5 °C

1. COOKING FUNCTION-STEAM

*To use this mode, the water tank needs to be filled with water.

1 In waiting state, turn the knob right to select the cooking mode. 8 modes are available.



2 Choose the "Steam" menu, "Steam" will flash.



3 Press "Start/Confirm" to confirm the cooking mode.



4 Turn the knob to set the temperature which should be within "80-100°C ", the default temperature is 100°C .

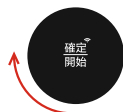

5 Press "Start/Confirm" to confirm.



6 Turn the knob to set the time which should be within "1-120minutes ", the default time is 15minutes.

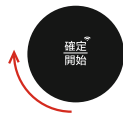

7 Press "Start/Confirm" to start cooking.



2. COOKING FUNCTION-HIGH TEMP. STEAM

*To use this mode, the water tank needs to be filled with water.

1 In waiting state, turn the knob right to select the cooking mode. 8 modes are available.



2 Choose the "High Temp. Steam" menu, "High Temp. Steam" will flash.



3 Press "Start/Confirm" to confirm the cooking mode.



4 Turn the knob to set the temperature which should be within "100-140°C ", the default temperature is 130°C.



5 Press "Start/Confirm" to confirm.



6 Turn the knob to set the time which should be within "1-60minutes ", the default time is 10 minutes.



7 Press "Start/Confirm" to start cooking.



3. COOKING FUNCTION- STEW

*To use this mode, the water tank needs to be filled with water.

1 In waiting state, turn the knob right to select the cooking mode. 8 modes are available.

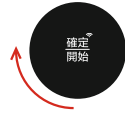

2 Choose the "Stew" menu, "Stew" will flash.



3 Press "Start/Confirm" to confirm the cooking mode.



4 Turn the knob to set the temperature which should be within "35-100°C ", the default temperature is 100°C.

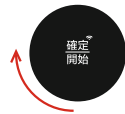

5 Press "Start/Confirm" to confirm.



6 Turn the knob to set the time which should be within "1min-5hrs ", the default time is 30 minutes.

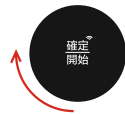

7 Press "Start/Confirm" to start cooking.



4. COOKING FUNCTION-CONVECTION

1 In waiting state, turn the knob right to select the cooking mode. 8 modes are available.



2 Choose the "Convection" menu, "Convection" will flash.

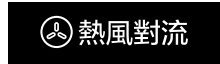

3 Press "Start/Confirm" to confirm the cooking mode.



4 Turn the knob to set the temperature which should be within "100-230°C ", the default temperature is 180°C.

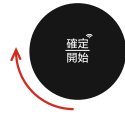

5 Press "Start/Confirm" to confirm.



6 Turn the knob to set the time which should be within "1-120minutes ", the default time is 30 minutes.

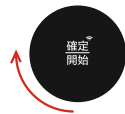

7 Press "Start/Confirm" to start cooking.



5. COOKING FUNCTION-COMBI.

*To use this mode, the water tank needs to be filled with water.

1 In waiting state, turn the knob right to select the cooking mode. 8 modes are available.



2 Choose the "Combi." menu, "Combi." will flash.



3 Press "Start/Confirm" to confirm the cooking mode.



4 Turn the knob to set the temperature which should be within "100-230°C", the default temperature is 190°C.

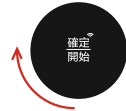

5 Press "Start/Confirm" to confirm.



6 Turn the knob to set the time which should be within "1-120minutes", the default time is 30 minutes.

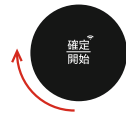

7 Press "Start/Confirm" to start cooking.



6. COOKING FUNCTION-CONVECTION GRILL

- 1** In waiting state, turn the knob right to select the cooking mode. 8 modes are available.
- 2** Choose the "Convection Grill" menu, "Convection Grill" will flash.
- 3** Press "Start/Confirm" to confirm the cooking mode.
- 4** Turn the knob to set the temperature which should be within "100-230°C ", the default temperature is 180°C.
- 5** Press "Start/Confirm" to confirm.
- 6** Turn the knob to set the time which should be within "1-120minutes ", the default time is 30 minutes.
- 7** Press "Start/Confirm" to start cooking.

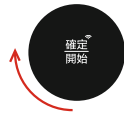
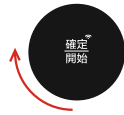

7. COOKING FUNCTION-GRILL

1 In waiting state, turn the knob right to select the cooking mode. 8 modes are available.



2 Choose the "Grill" menu, "Grill" will flash.



3 Press "Start/Confirm" to confirm the cooking mode.



4 Turn the knob to set the temperature which should be within 100-200°C, the default temperature is 180°C.



5 Press "Start/Confirm" to confirm.



6 Turn the knob to set the time which should be within "1-120minutes", the default time is 30 minutes.

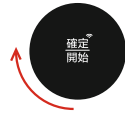

7 Press "Start/Confirm" to start cooking.



8. COOKING FUNCTION-FERMENTATION

*To use this mode, the water tank needs to be filled with water.

1 In waiting state, turn the knob right to select the cooking mode. 8 modes are available.



2 Choose the "Fermentation" menu, "Fermentation" will flash.



3 Press "Start/Confirm" to confirm the cooking mode.



4 Turn the knob to set the temperature which should be within "30-45°C", the default temperature is 35°C.

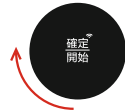

5 Press "Start/Confirm" to confirm.



6 Turn the knob to set the time which should be within "1 min-12hrs", the default time is 40 minutes.

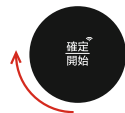

7 Press "Start/Confirm" to start cooking.



9. PREHEAT FUNCTION

- 1** In waiting state, turn the knob right to select the preheating function.



- 2** Press "Start/Confirm" to confirm.



- 3** Turn the knob to set the temperature which should be range "100-230°C ", the default temperature is 180°C.



- 4** Press "Start/Confirm" to start preheating.



- 5** The buzzer will sound three times to remain that the preheating has finished, opening and close the oven door, "Convection" will flash, another two menus and the default time "30:00" will display meanwhile.



- 6** Turn the knob to select the cooking mode, "Convection", "Combi." and "Convection Grill" are available.

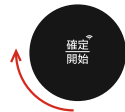

- 7** Press "Start/Confirm" to confirm.



9.PREHEAT FUNCTION

8 Turn the knob to set the temperature.



9 Press "Start/Confirm" to confirm.



10 Turn the knob to set the time.

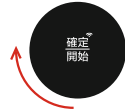

11 Press "Start/Confirm" to start cooking.



NOTE

- When the preheating temperature has not been reached within 30 minutes, the buzzer will sound three times to force the preheating to complete and enter the heat preservation stage
- In heat preservation stage, if the oven door not be opened within 60 minutes. it return to the standby state with one buzzing sound. In the process of waiting for 60 minutes, the buzzer will sound three times every 15 seconds.

10.AUTO MENU (02-03,05-07,09-17,24,33-36)– PREHEAT

- 1** In waiting state, turn the knob right to select the "Auto Menu" mode.
- 2** Press "Start/Confirm" to confirm.
- 3** Turn the knob to select the desired menu. (e.g Auto Menu 02)
- 4** Press "Start/Confirm" to confirm .
- 5** Turn the knob to set the cook time of the homologous menu. (Can skip this step)
- 6** Press "Start/Confirm" to start preheating.
- 7** After the preheating is completed, the "Preheat" light will flash to indicate that the preheating is complete, put the food in the oven, and then press "Start/Confirm" to start cooking.

自動功能

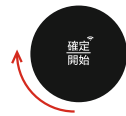

10.AUTO MENU(01,04,08,18-23,25-32)– NO PREHEAT

1 In waiting state, turn the knob right to select the "Auto Menu" mode.

自動功能

2 Press "Start/Confirm" to confirm .



3 Turn the knob to select the desired menu. (e.g Auto Menu 01)

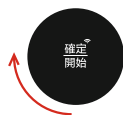

4 Press "Start/Confirm" to confirm .



5 Turn the knob to set the time. (Can skip this step)



6 Press "Start/Confirm" to start cooking.



NOTES

- " 爐腔預熱 " will flash in those menu which have preheat function when the preheating has finished.
- Press "Start/Confirm" to start cooking directly between "37-40" menus when the homologous number flashing.

10.AUTO MENU(37-40)-CLEANING

1 In waiting state, turn the knob right to select the "Auto Menu" mode.

自動功能

2 Press "Start/Confirm" to confirm.



3 Turn the knob to select the desired menu. (e.g Auto Menu 37)



4 Press "Start/Confirm" to cleaning. (e.g Auto Menu 37)



• Tableware disinfection (Auto Menu 37)

This function is suitable for sterilizing all kinds of tableware (heat resistance higher than 100°C).

*When using the tableware cleaning function, please make sure that the heat resistance of tableware is higher than 100°C and that the water box is filled with water.

Cleaning time
30 minutes

• Cavity cleaning (Auto Menu 38)

Clean the oven cavity with steam and heat, which is suitable for cleaning the oven cavity after cooking. The machine will spray steam to soften the stains, which will make it easier to wipe the stains away.

* When using the oven cavity cleaning function, please confirm that the water box has been filled with water.

Cleaning time
10 minutes

• Cavity deodorization (Auto Menu 39)

Use it after cooking or after Menu 38. Wipe and clean the cavity first, and then select this function to remove the residual smell from the cavity by the built-in fan.

Cleaning time
5 minutes

• Steam System Cleaning (Auto Menu 40)

Step 1 "PP1" (with citric acid) cleaning (55 minutes)

- 1.Put 10g citric acid into 500ml water; stir to melt the citric acid then pour it into water tank.
- 2.Select auto function 40 Steam System Cleaning,press "開始" to start steam system cleaning.

Step 2 "PP2" (water) cleaning (5 minutes)

- 3.When the remaining cleaning time is 5 minutes, the oven will be paused and the screen will display "PP2" and "5:00". Please pour the water with citric acid from the water tank and replace it with clean water.

- 4.Put the water tank back into the oven, press "開始" to start Steam System Cleaning function will start auto matically to finish the remaining cleaning process.

Cleaning time
60 minutes

*Please don't use other substances, such as detergent, except citric acid.

10.AUTO MENU SETTING

Function	Function Name	Quantity /weight	Preheat	Default temperature	Default time	Optional time	Place	Power
A01	Roast Chicken	1100g	/	220°C	41 mins	33-49 mins	lower layer	Convection +Combi.
A02	French Lamb Rack	820g	V	200°C	35 mins	28-41 mins	middle layer	Combi.
A03	Crispy Golden Char Siu	450g	V	170°C+190°C	45 mins	36-54 mins	middle layer	Combi.
A04	German Pork Knuckle	1300g	/	100°C+130°C+200°C+200°C	146 mins	117-175 mins	lower layer	Steam +Convection +Combi.
A05	Roasted Steak with Black Pepper	500g	V	230°C	10 mins	8-12 mins	top layer	Convection
A06	Baked Lobster with Cheese	650g	V	200°C	17 mins	14-20 mins	middle layer	Convection +Grill
A07	Baked Scallop with Cheese	8	V	230°C	9 mins	7-11 mins	top layer	Convection
A08	Barbecue Pork Ribs	500g	/	170°C	36 mins	29-43 mins	middle layer	Combi.
A09	Grilled Cod Fish	220g	V	230°C	9 mins	7-11 mins	top layer	Convection
A10	Honey Black Pepper Chicken Wings	450g	V	220°C	17.5 mins	14-21 mins	middle layer	Combi.
A11	Shrimps Skewers	600g	V	230°C	10 mins	8-12 mins	top layer	Convection
A12	Grilled Shrimps	250g	V	230°C	7 mins	6-8 mins	top layer	Convection
A13	Bacon Asparagus Roll	300g	V	230°C	8 mins	7-9 mins	middle layer	Combi.
A14	Satay Chicken Skewers	1000g	V	230°C	17 mins	14-20 mins	top layer	Convection
A15	Julienne Vegetable-Stuffed Chicken	550g	V	210°C	28 mins	22-34 mins	middle layer	Convection
A16	Curry Chicken Skewers	200g	V	230°C	15 mins	12-18 mins	middle layer	Combi.
A17	Seafood Pizza	600g	V	200°C	24 mins	19-29 mins	middle layer	Convection
A18	Braised Chicken with Chestnuts	800g	/	100°C	30 mins	24-36 mins	middle layer	Steam
A19	Steamed Osmanthus fish	500g	/	100°C	18 mins	15-21 mins	middle layer	Steam
A20	Steamed Pork Belly with Preserved Vegetable	1000g	/	100°C	60 mins	48-72 mins	lower layer	Steam
A21	Steamed Sole Fillet	500g	/	100°C	18 mins	15-21 mins	middle layer	Steam
A22	Steamed Eggs with Crab	300g	/	100°C	10 mins	8-12 mins	middle layer	Steam
A23	Steamed Pork Ribs with Pumpkin	600g	/	100°C	18 mins	15-21 mins	middle layer	Steam

10.AUTO MENU SETTING

Function	Function Name	Quantity /weight	Preheat	Default temperature	Default time	Optional time	Place	Power
A24	Steamed Asparagus	300g	V	230°C	9 mins	7-11 mins	middle layer	Combi.
A25	Stewed Lamb Chops with Matsutake	2000g	/	100°C	90 mins	72-108 mins	lower layer	Steam
A26	Steamed Sea Bass	490g	/	120°C	15 mins	12-18 mins	middle layer	High Temp. Steam
A27	Pork and Cabbage Dumplings	500g	/	100°C	20 mins	16-24 mins	middle layer	Steam
A28	Pork and Mushroom Steamed Buns	12	/	100°C	25 mins	20-30 mins	middle layer	Steam
A29	Steamed Chicken with Sand Ginger Powder	900g	/	110°C	40 mins	32-48 mins	lower layer	High Temp. Steam
A30	Steamed Pear with Rock Sugar	2000g	/	100°C	60 mins	48-72 mins	lower layer	Steam
A31	Jujube and Ginger Juice Steamed Cake	1200g	/	100°C	45 mins	36-54 mins	lower layer	Steam
A32	Sweet Green Rice Ball	12	/	100°C	12.5 mins	10-15 mins	middle layer	Steam
A33	Almond Tuiles	325g	V	150°C	24 mins	19-29 mins	middle layer	Convection
A34	Cranberry Cookies	450g	V	160°C	23 mins	18-28 mins	middle layer	Convection
A35	Rye Bread	500g	V	210°C	21mins	17-27 mins	middle layer	Convection
A36	Cranberry Bread	400g	V	170°C	25 mins	21-29 mins	middle layer	Convection
A37	Tableware Disinfection	/	/	100°C	30 mins	/	/	/
A38	Cavity Cleaning	/	/	/	10 mins	/	/	/
A39	Cavity Deodorization	/	/	/	5 mins	/	/	/
A40	Steam System Cleaning	/	/	/	60 mins	/	/	/

OVEN LIGHT



During standby or cooking, you can touch “” to turn on/off the oven lamp, so that you can observe the food in the oven at any time.

CHILDREN LOCK FUNCTION

You can use this function to prevent children from accidentally turning the oven on.

- 1** To activate the lock: In waiting state, **press** and hold "Pause/Cancel" for three seconds. A long beep sounds and the  will display.



- 2** To deactivate the lock: In locked state, **press** and hold "Pause/Cancel" for three seconds. One short beep sounds and the locked icon  will disappear.



SIGNAL INDICATION



Oven overheat

If "F01" appears, it indicates that the oven chamber temperature is higher than the functional temperature range, and the product can be used only after it is cooled down.

Water shortage

If "F02" appears, and 5 beep sounds, it indicates that the clean water box is short of water or not installed in place. Please add water to clean water box until reach "MAX" line, then reload the water box to the oven to continue cooking process.

Standby mode

In the standby mode, the oven is left idle for 5 minutes, the whole panel will be off.

To activate the oven to the standby mode, rotate the knob "⌚", press any of the functions or open the oven door.

Selection process

During the function selection process, if the oven is left idle for 5 minutes, the selection process will be canceled.



OTHER IMPORTANT TIPS

- When baking food in the oven, please spread tin foil on the baking tray, and then put the food on it. Please do not directly stain the baking tray with acidic substances, such as vinegar, lemon and juice.
- After using of the steaming function, it is recommended to open the oven door, which is helpful to remove the accumulated water.
- The oven door seal is designed to be removable. If water drops or food residues get stuck in the oven door seal, please remove the seal carefully, wipe it with a soft cloth after wringing out the moisture, wipe it clean, and then put it back.
- Steam might leaks out from all four sides of the oven door. When a function related to steam is used, a lot of steam are generated in the oven cavity during operation of the product. Some steam may leak from all four sides of the oven door. It is normal.

Warning

- 1** Do not scratch the seal with much effort. Otherwise steam is easy to escape.
- 2** Please install/remove the seal carefully; otherwise, steam may leak.
- 3** Be sure to install the seal before using the oven.

MAINTENANCE

TROUBLESHOOTING



Check your problem by using the chart below and try the solutions for each problem.

Trouble	Possible Cause	Possible Remedy
Oven will not start	a. Electrical cord for oven is not plugged in. b. Door is open. c. Wrong operation is set.	a. Plug into the outlet. b. Close the door and try again. c. Check instructions
Arcing or sparking	a. Materials to be avoided in microwave oven were used. b. The oven is operated when empty. c. Spilled food remains in the cavity.	a. Use microwave-safe cookware only. b. Do not operate with oven empty. c. Clean cavity with wet towel.
Unevenly cooked foods	a. Materials to be avoided in microwave oven were used. b. Food is not defrosted completely. c. Cooking time, power level is not suitable. d. Food is not turned or stirred.	a. Use microwave-safe cookware only. b. Completely defrost food. c. Use correct cooking time, power level. d. Turn or stir food.
Overcooked foods	Cooking time, power level is not suitable.	Use correct cooking time, power level.
Undercooked foods	a. Materials to be avoided in microwave oven were used. b. Food is not defrosted completely. c. Oven ventilation ports are restricted. d. Cooking time, power level is not suitable.	a. Use microwave-safe cookware only. b. Completely defrost food. c. Check to see that oven ventilation ports are not restricted. d. Use correct cooking time, power level.
Improper defrosting	a. Materials to be avoided in microwave oven were used. b. Cooking time, power level is not suitable. c. Food is not turned or stirred.	a. Use microwave-safe cookware only. b. Use correct cooking time, power level. c. Turn or stir food.
Sensor cooked foods not properly cooked	a. Cover or lid on food not vented. b. Door opened before sensor-detected cooking time appears in display.	a. Cover or lid over food must contain vent hole for escaping steam. b. Do not open door to stir or turn food before sensor-detected cooking time appears in display.

PRODUCT PARAMETERS

Volume	30L	Grill power	1500-1600W
Rated voltage/ frequency	220-230V~50Hz	Combination	1550-1700W
Convection power	1550-1700W	Overall dimensions (width x depth x height)	472x465x375 mm
Steam power	1500-1600W	Oven cavity dimensions (width x depth x height)	410x325x230 mm

- 1** The product dimensions are width × depth × height, and the overall depth includes the length of handle and back plate stretching length, and the height value includes oven foot.
- 2** The dimensions of the oven cavity includes the stretching length, and the cavity volume is obtained by multiplying the width, depth and height. Due to the continuous upgrading of products, there may be differences between volume parameters and labeled data, with a deviation range of ±12%.
- 3** As our products are constantly improving, the physical parameters may be different from those labeled. Please refer to the physical parameters for specific parameters.

Product videos



#DetailsMatter