

OWNER'S MANUAL

SEARS

Kenmore

SEWING MACHINE

MODEL 385. 17928

SEARS, ROEBUCK AND CO.

Dear Customer:

You have just invested in a very fine zigzag sewing machine. Before using your new Kenmore machine, please pause for a moment and carefully read this booklet which contains instructions on how to operate and care for your machine.

Specific instructions are given on threading, tension adjustments, cleaning, oiling, etc. This will help you obtain the best sewing results and avoid unnecessary service expense for conditions beyond our control.

Advice on the operation and care of your machine is always available at your nearest Sears Retail Store. Please remember, if you have questions about your machine or need parts and service, always mention the model number and serial number when you inquire.

Kenmore Sewing Machine

Record in space provided below the model number and serial number of this appliance. The model number and serial number are located on the nomenclature plate, as identified on Page 4 of this booklet.

Model No. 385.

Serial No.

Retain these numbers for future reference.

THIS MODEL IS A CENTER NEEDLE, LOW BAR SEWING MACHINE.

IMPORTANT SAFETY INSTRUCTIONS

Your sewing machine is designed and constructed only for HOUSEHOLD use. Read all instruction before using this sewing machine.

DANGER — To reduce the risk of electric shock:

1. An appliance should never be left unattended when plugged in. Always unplug this appliance from the electric outlet immediately after using and before cleaning.
2. Always unplug before relamping. Replace bulb with same type rated 15 Watts.
3. Do not reach for the appliance that has fallen into water. Unplug immediately.
4. Do not place or store appliance where it can fall or be pulled into a tub or sink. Do not place in or drop into water or other liquid.

WARNING — To reduce the risk of burns, fire, electric shock,

or injury to persons.

1. Do not allow to be used as a toy. Close attention is necessary when this appliance is used by or near children.
2. Use this appliance only for its intended use as described in this manual. Use only attachments recommended by the manufacturer as contained in this manual.
3. Never operate this appliance if it has a damaged cord or plug, if it is not working properly, if it has been dropped or damaged, or dropped into water. Return the appliance to the nearest authorized dealer or service center for examination, repair, electrical or mechanical adjustment.

4. Never operate the appliance with any air opening blocked. Keep ventilation openings of the sewing machine and foot controller free from accumulation of lint, dust, and loose cloth.
5. Never drop or insert any object into any opening.
6. Do not use outdoors.
7. Do not operate where aerosol (spray) products are being used or where oxygen is being administered.
8. To disconnect, turn all controls to the off ("O") position, then remove plug from outlet.
9. Do not unplug by pulling on cord. To unplug, grasp the plug, not the cord.
10. Keep fingers away from all moving parts. Special care is required around the sewing machine needle.
11. Always use the proper needle plate. The wrong plate can cause the needle to break.
12. Do not use bent needles.
13. Do not pull or push fabric while stitching. It may deflect the needle causing it to break.
14. Switch the sewing machine off ("O") when making any adjustment in the needle area, such as threading needle, changing needle, threading bobbin, or changing presser foot, and the like.
15. Always unplug the sewing machine from the electrical outlet when removing covers, lubricating, or when making any other adjustments mentioned in the instruction manual.

SAVE THESE INSTRUCTIONS

TABLE OF CONTENTS

SECTION 1. KNOW THE MACHINE

A Portable Case or Cabinet is Available	3
Locate and Identify the Parts	3~4
Identify the Accessories	5

SECTION 2. PREPARE THE MACHINE FOR SEWING

Set Up the Machine	6~10
• Plug in the Machine and Switch on the Power	6
• Foot Control Use	6
• Set the Pressure Dial	7
• Adjust the Presser Foot Lever	8
• Thread Cutter	8
• Accessory Storage Box	9
• Free Arm Sewing: the Removable Extension Table	9~10
Know What the Presser Feet Will Do	11~14
• Check the Presser Foot	11
• Change the Presser Foot	11
• Presser Foot Types	12~14
Choose the Needle and Thread	14~15
• Check the Needle	14
• Fabric, Needle, Thread and Stitch Length Chart	15
• To Change the Needle	15
Prepare the Bobbin	16~18
• To Remove the Bobbin from the Machine	16
• Horizontal Spool Pin	16
• Additional Spool Pin	16
• Bobbin Winding	17
• Insert the Bobbin into the Bobbin Holder	18
Prepare the Top Thread	19~22
• Thread the Needle	19
• Pick Up the Bobbin Thread	20
• Adjust the Top Thread Tension	21~22
Stitch Selector	23
Stitch Width Control	24
Stitch Length Control	24
Adjusting Stretch Stitch Balance	24
Reverse Stitch Control	25
Starting To Sew	25

SECTION 3. LEARN THE STITCHES

Practical Stitch Chart	26~30
Straight Stitches	31~35
• Straight Stitches	31
• Use the Seam Guides	31
• Turn a Square Corner	31
• Topstitching	32
• Sew in a Zipper	33~34
• Dropping the Feed Dogs	35

• Darning	35
Zigzag Stitches	36~48
• Basic Zigzag	36
• Monogramming	36
• Satin Stitch	37
• Applique	38
• Bar Tacking	38
• Embroidery	39
• Sew a Button	40
• Overcasting Stitch	41
• Blind Hemming	42
• Lace Work	43
• Three-Step Zigzag	44
• Shell Stitching	45
• Box Stitching	45
• Fagoting Stitch	46
• Two-Point Shell Stitching	46
• Two-Point Box Stitch	47
• Overedging Stitch	47
• Decorative with Geometric Patterns	48
Stretch Stitches	49~53
• Straight Stretch	49
• Rick-Rack Stretch	49
• Overcast Stretch Stitching	50
• Smocking	50
• Serging or Pine Leaf Stretch Stitching	51
• Elastic Stretch Stitch	51
• Stretch Patching	52
• Herring Bone Stretch	52
• Decorative Stretch Patterns	53
Buttonhole Making	54~60
• Learning to Sew Buttonholes	54
• Built-in System	55~56
• Using Buttonhole Attachment (Optional Item)	57~60
Twin Needle Stitches (Optional Item)	61

SECTION 4. PERFORMANCE PROBLEM CHART

What to do When	62~63
-----------------	-------

SECTION 5. CARE FOR THE MACHINE

Replace the Light Bulb	64
Clean the Bobbin Holder	64
Clean the Hook Race and Feed Dogs	65
Oiling the Machine	65

PARTS LIST	66~67
------------	-------

INDEX	68~69
-------	-------

A Portable Case or Cabinet is Available

A full line of sewing cabinets is available at your nearest Sears retail store or through our general catalog.

Another option . . . buy a Carrying Case . . . then your Kenmore goes anywhere, can be stored anywhere.

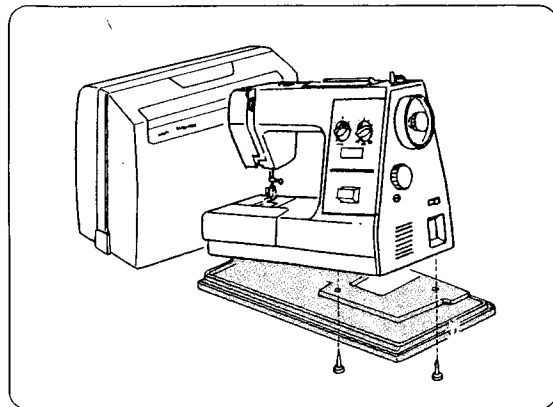
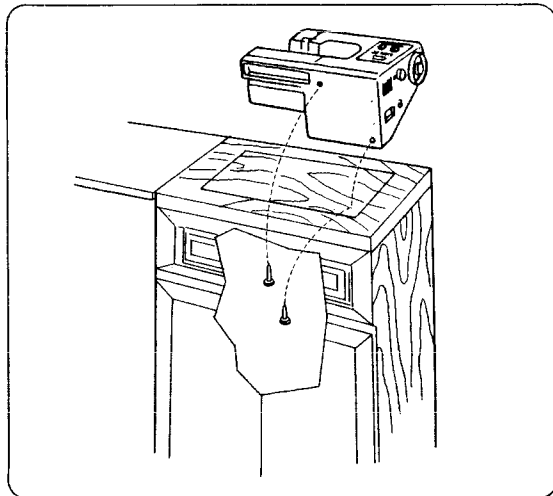

Locate and Identify the Parts

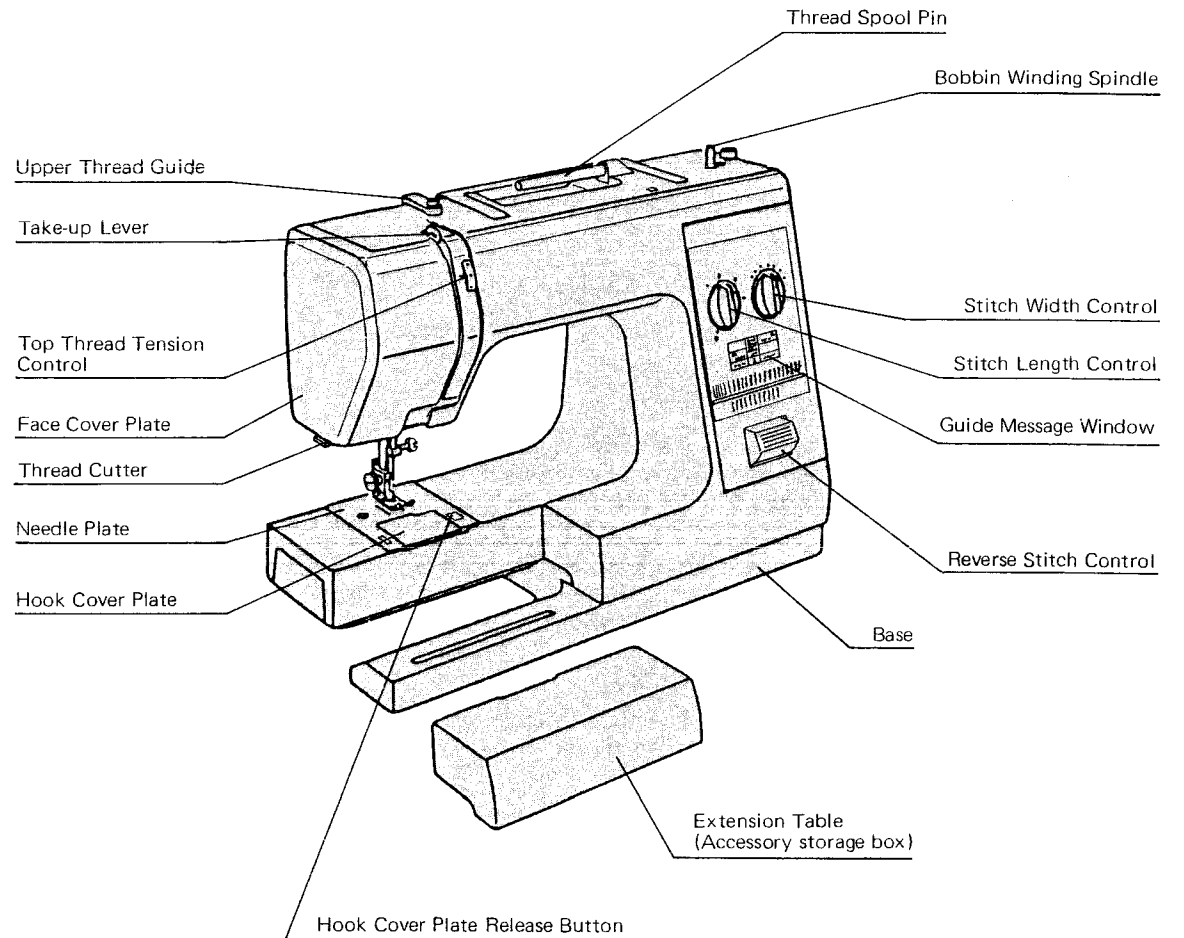

SECTION 1: KNOW THE MACHINE

Locate and Identify the Parts (Continued)

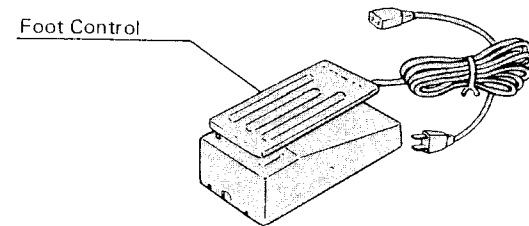
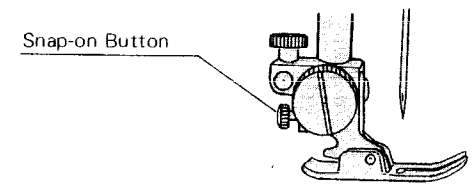
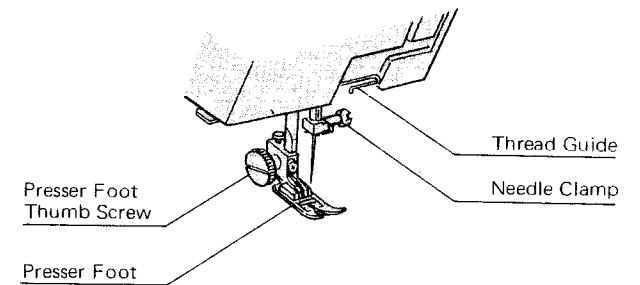
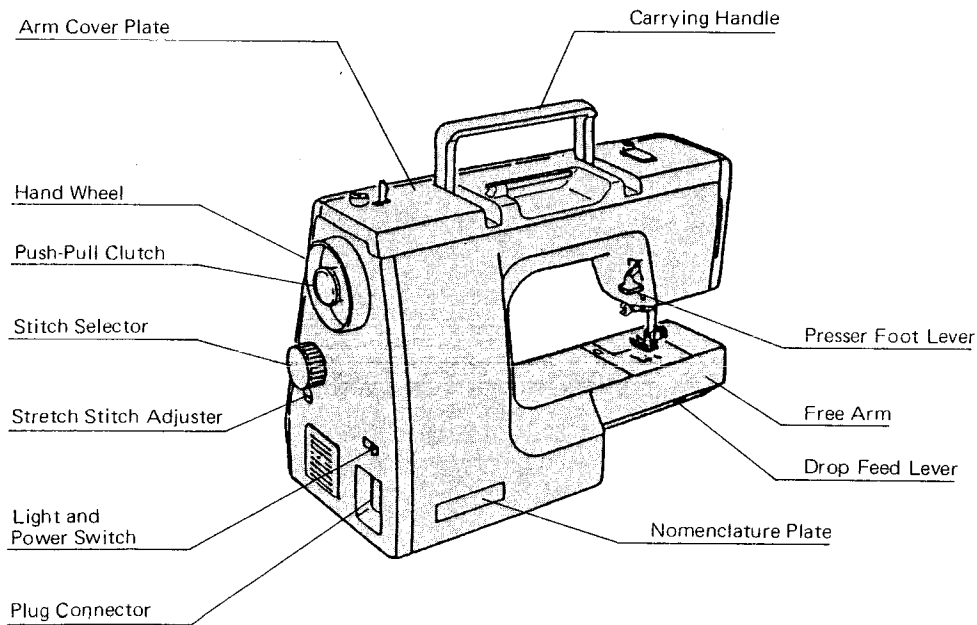

Identify the Accessories

Bobbin

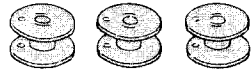

Buttonhole opener

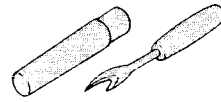

Needle set

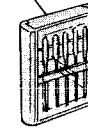

Lint brush

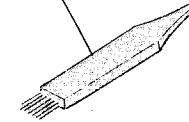

Large screw driver

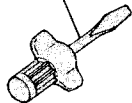

Small screw driver

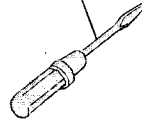

Additional spool pin

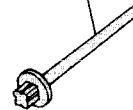

Spool pin felt



Small spool holder



Large spool holder



Zipper foot

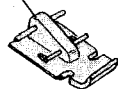

Straight stitch foot



Sliding buttonhole foot

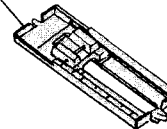

Satin stitch foot

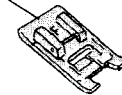

SECTION 2 PREPARE THE MACHINE FOR SEWING

Set Up the Machine

• Plug in the Machine and Switch on the Power

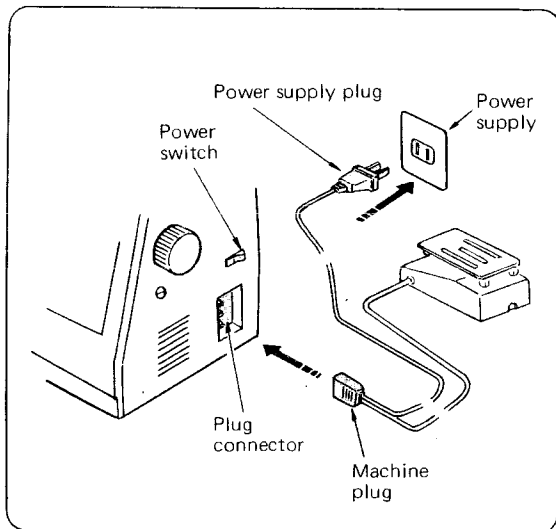

NOTE: Before inserting the plug into your machine, be sure the power switch is OFF.

1. Check your outlet to be sure it is a 110 to 120 Volt AC outlet.
2. Insert the machine plug into the three-prong outlet, as shown. It will only fit one way.
3. Insert the power supply plug into the outlet.

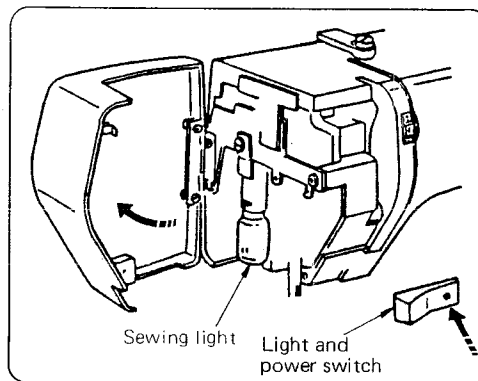

4. Push the light and power switch to turn on the power and sewing light.

SAFETY FEATURE:

Your machine will not operate unless the light/power switch is turned on. If you are interrupted or stop sewing, turn off the light/power switch to prevent injury to children.

• Foot Control Use

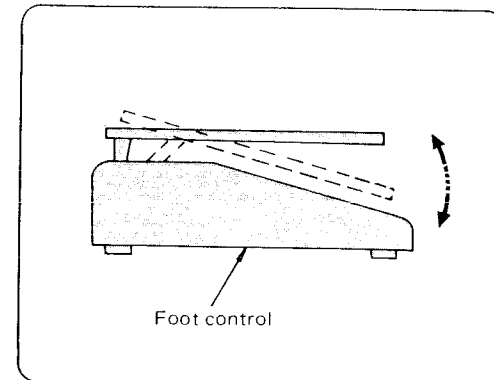

The foot control regulates the speed at which you sew.

To increase speed, gently press down with the ball of your foot.

To decrease speed, release your foot pressure slightly.

NOTE: The foot control is sensitive and will increase or decrease your sewing speed immediately. Practice on a scrap of fabric to regulate your sewing speed to your taste and needs.

- Set the Pressure Dial

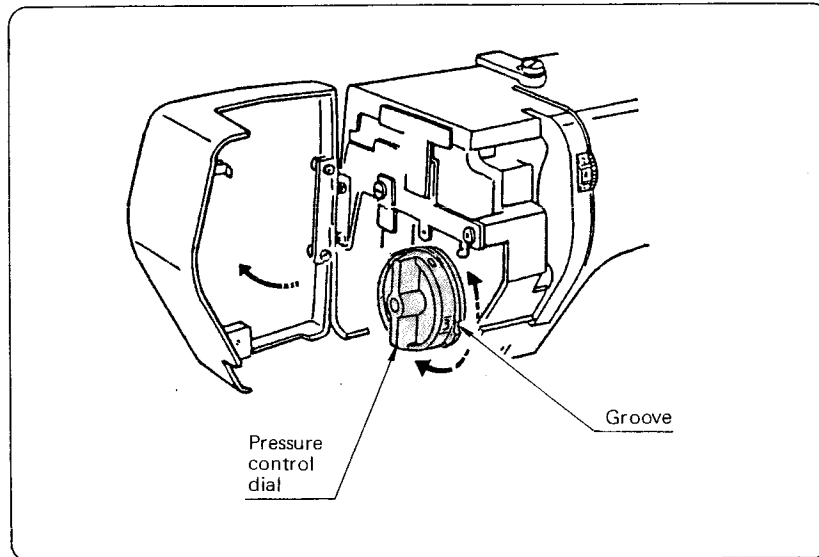

The pressure control dial is located inside the face cover plate.

Set the dial aligning the setting mark on the dial with the groove as follows.

- 3 most sewing
- 2 applique and Cut-Out work
- 1 sewing chiffon, lace, organdy and other lightweight fabrics.
Also for velours and knits (with more stretch).
- 0 manual darning and embroidery

NOTE: The pressure dial should be reset at 3 after changing pressure, so the machine is ready for most normal sewing the next time you use it.

SECTION 2. PREPARE THE MACHINE FOR SEWING

Set Up the Machine (Continued)

- Adjust the Presser Foot Lever

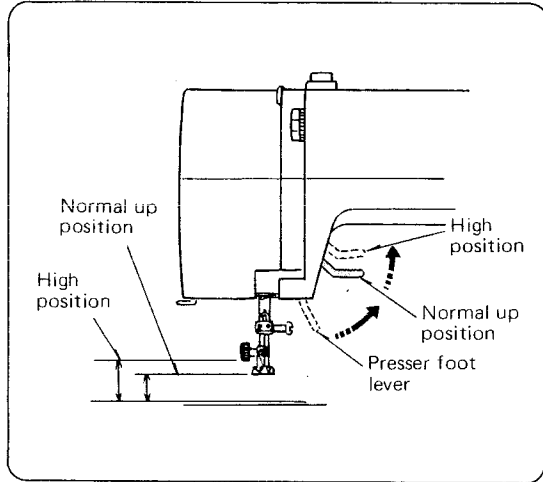

The Presser Foot Lever raises and lowers your presser foot.

You can raise it about 1/4" higher than the normal up position for easy removal of the presser foot or to help you place heavy fabrics under the presser foot.

- Thread Cutter

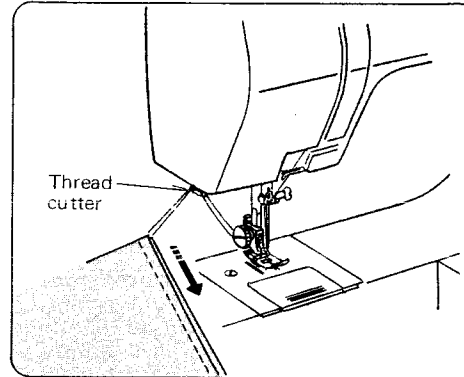

You don't need a pair of scissors to cut the thread after you finish sewing. Just use the handy thread cutter.

• **Accessory Storage Box**

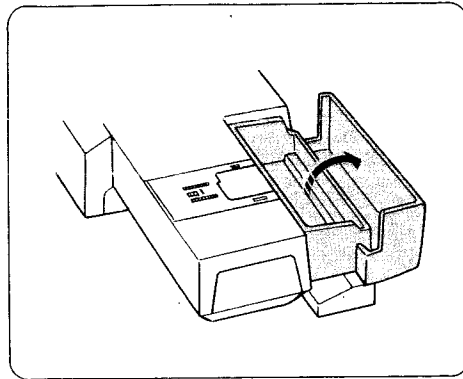

The lid of the accessory storage box lifts open toward you.

Sewing accessories are conveniently located in the box.

• **Free-Arm Sewing: the Removable Extension Table**

To remove:

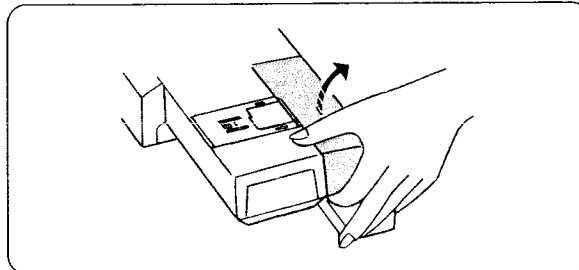

To Remove the Extension Table
(for free-arm sewing)

1. Grip the table with your index finger and thumb, as shown.
2. Pull it gently toward you.
The extension table will snap out.

To Attach:

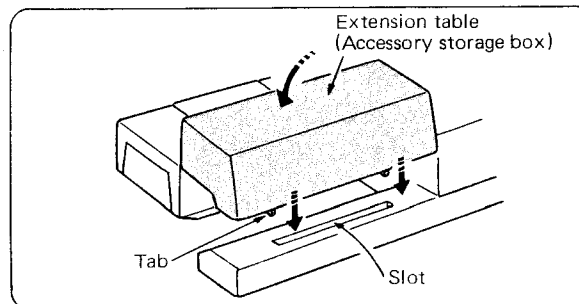

To Attach the Extension Table
(for flat-bed sewing)

1. Fit the tabs into the slot, as shown.
2. With your thumb and index finger, gently snap in.

Your sewing machine can do free arm sewing. This feature makes sewing easy for:

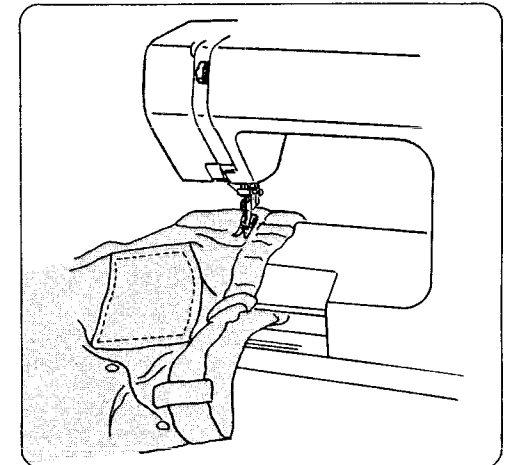

- * Bar tacking to reinforce pockets, plackets and waistlines on ready-made or home-made garments to avoid fabric bunching around the needle.

SECTION 2 PREPARE THE MACHINE FOR SEWING

Set Up the Machine (Continued)

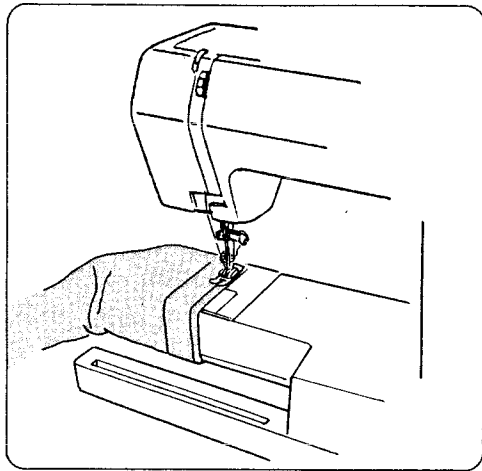

* Stitching sleeves, waistbands, pants legs, or any circular garment area.

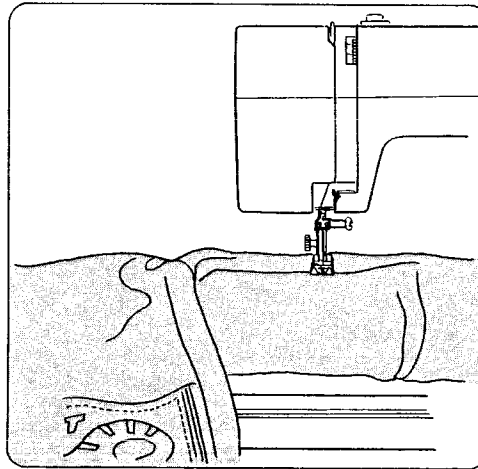

* Darning socks or mending knees, elbows, or areas of wear in children's clothes.

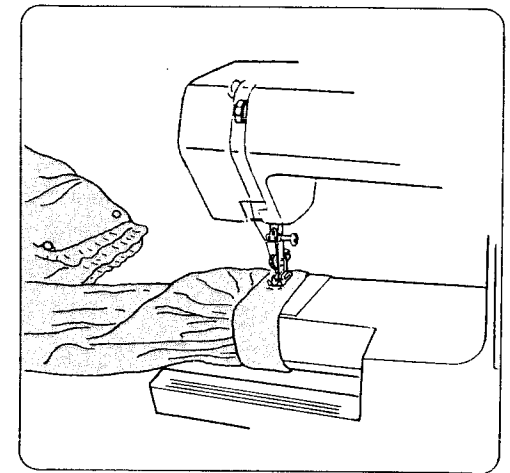

* Sewing buttons on sleeves, waistbands, etc.

Know What the Presser Feet Will Do

- **Check the Presser Foot**

The Presser feet are an important feature of this machine. You need to know what each foot does in order to use them effectively.

Your presser foot is held in place by a Foot Holder. Each presser foot merely snaps on the foot holder, which is seldom removed.

If you need to remove or attach the foot holder, here is what you do:

To Remove:

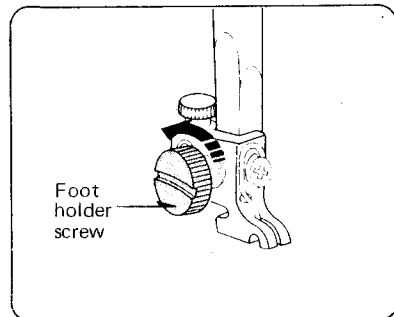

To Remove:

Turn the screw toward the back of the machine. Use the large screw driver.

To Attach:

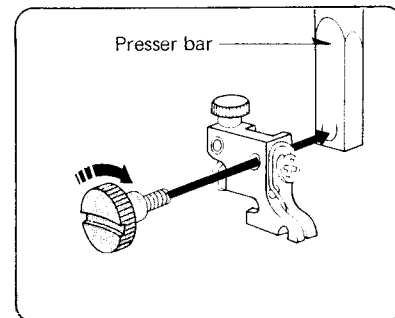

To Attach:

1. Match the hole in the foot holder with the threaded hole in the presser bar.
2. Fit the foot holder screw into the hole.
3. Tighten the screw by turning it toward you.

- **Change the Presser Foot**

Use the correct presser foot for the stitch you wish to sew. Consult the Stitch Pattern Chart and the detailed directions for sewing with the various presser feet.

To Snap Off:

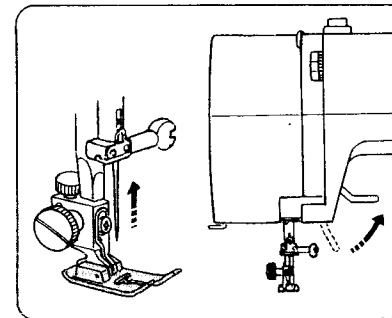

To Snap Off the Presser Foot:

1. Raise the needle bar to its highest position by turning the hand wheel toward you.
2. Raise the presser foot.
3. Press the snap-on button on the back of the foot holder. The presser foot will drop off.

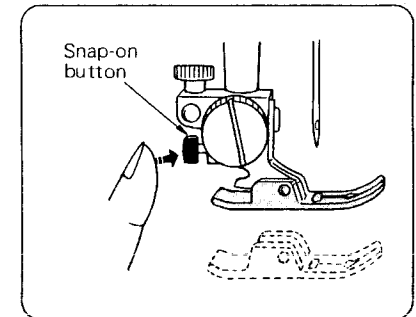

SECTION 2 PREPARE THE MACHINE FOR SEWING

Know What the Presser Feet Will Do (Continued)

• Change the Presser Foot (Continued)

To Snap On

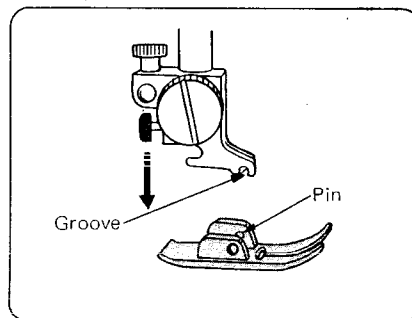

To Snap On the Presser Foot:

1. Place the presser foot so the horizontal pin on the foot lies just under the groove of the foot holder.
2. Lower the presser foot holder to lock the presser foot in place.

NOTE: If you do not hear the presser foot snap in place, press down on the presser foot holder firmly until you hear the snap.

• Presser Foot Types

Zigzag Foot

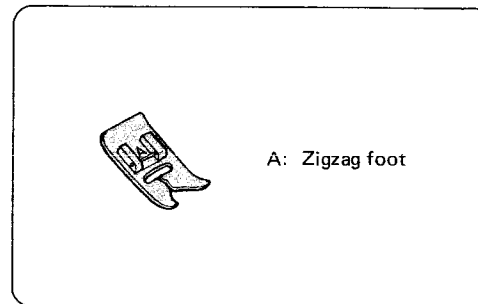

Use this foot for both straight and zigzag stitching.

Uses: Zigzag stitching (see page [36](#)),
Bar tacking (see page [38](#)),
Button sewing (see page [40](#)),
Overcast stitch (see page [41](#)),
Lace work (see page [43](#)),
Three-step zigzag (see page [44](#)),
Box stitching (see page [45](#)),
Two-point shell stitching (see page [46](#)),
Fagoting (see page [46](#)),
Two-point box stitch (see page [47](#)),
Overedging stitch (see page [47](#)),
Rick-rack stretch (see page [49](#)),
Smocking (see page [50](#)),
Elastic stretch (see page [51](#)),
Stretch patching (see page [52](#)),
Herring bone stretch (see page [52](#)).

Straight Foot

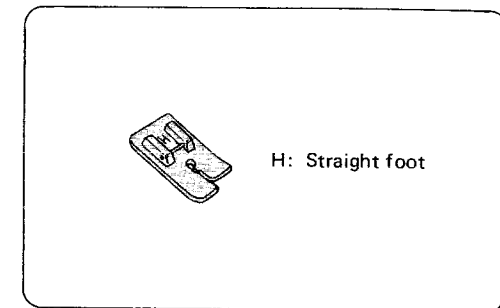

Use this foot exclusively for straight stitching using center needle position only.

Uses: Straight stitching (see page [31](#)),
Topstitching (see page [33](#)),
Straight stretch (see page [49](#)).

• Presser Foot Types (Continued)

Sliding Buttonhole Foot

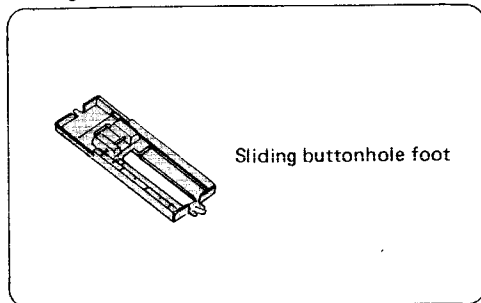

Use this foot for buttonholes of built-in system. It is marked to measure your buttonholes accurately.

Uses: Buttonhole making (see page 55).

Zipper Foot

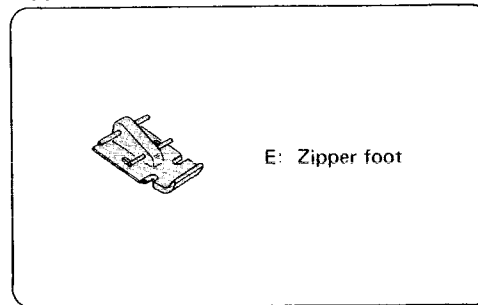

This foot can be set to sew on each side of your zipper. The edges of the foot guide the zipper and keep the seam straight.

Uses: Zipper application (see page 34).

Satin Stitch Foot

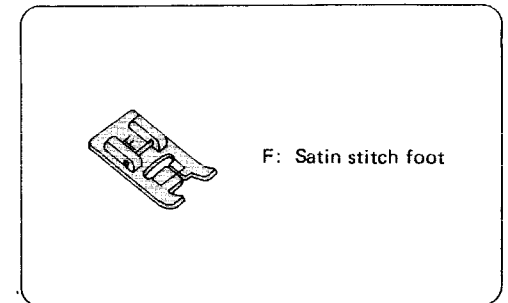

Use this transparent foot for satin stitch and outlining applique.

Uses: Darning (see page 32),
 Monogramming (see page 36),
 Satin stitch (see page 37),
 Applique (see page 38),
 Shell stitching (see page 45),
 Geometric decorative stitching
 (see page 48).

SECTION 2. PREPARE THE MACHINE FOR SEWING

Choose the Needle and Thread

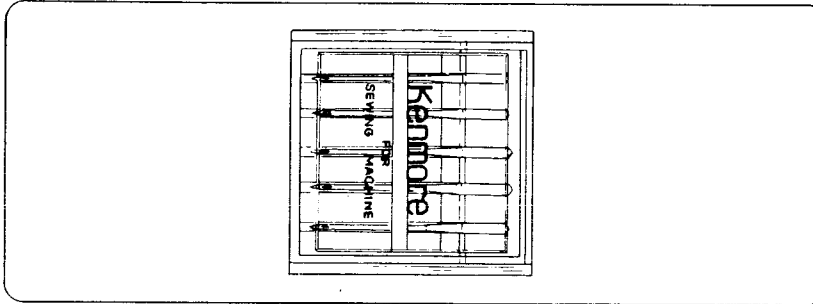

Your choice of needle and thread depends on the fabric you are sewing.

In the needle case, you will find the following color-coded needles:

- Blue (11) for stretch fabrics
- Orange (11) for lightweight fabrics
- Red (14) for medium or medium-heavy weight fabrics
- Purple (16) for medium-heavy weight and decorative topstitching on these fabrics
(This needle has a larger thread hole for thicker topstitching thread.)
- Green (18) for heavy weight fabrics and decorative topstitching on these fabrics

• Check the Needle

1. Look for barbed or blunt point.
2. A damaged needle can cause permanent snags or runs in knits, fine silks and silk-like fabrics.

Always buy a good quality thread. It should resist tangling and be strong, smooth and consistent in thickness.

SECTION 2 PREPARE THE MACHINE FOR SEWING

• Fabric, Needle, Thread and Stitch Length Chart

FABRIC	NEEDLE SIZE AND COLOR	THREAD SIZE	RECOMMENDED STITCH LENGTH SETTING
Lightweight: Batiste, Dimity, Chiffon, Silks, Fine Lace, Organza, Crepe, Taffeta, Voile, Organdy	11-ORANGE	Polyester Core/Cotton Wrap Fine Mercerized Cotton Silk A	2 (12 stitches per inch)
Medium Weight: Cotton, Cotton Blends, Percalé, Gingham, Shantung, Pique, Seersucker, Satin, Knits, Suitings, Linen, Wool Crepe, Leather	14-RED	50 Mercerized Cotton Polyester Core/Cotton Wrap Silk A	2-2.5 (10-12 stitches per inch)
Medium Heavy Weight: Corduroy, Denim, Wool, Sailcloth, Wool Flannel, Gabardine, Velvets, Leather	14-RED or 16-PURPLE	50 Mercerized Cotton Mercerized Heavy-Duty Polyester Core/Cotton Wrap Silk A	2-3 (8-10 stitches per inch)
Heavy Weight: Coatings, Upholstery Cotton Duck, Heavy Twill, Canvas	16-PURPLE 18-GREEN	Heavy Duty Mercerized Cotton Polyester Core/Cotton Wrap Silk A	3 (8 stitches per inch)
Decorative top-stitching on all types of fabric	16-PURPLE 18-GREEN	Buttonhole Twist (Use as top thread only)	3-4 (6-8 stitches per inch)
Stretch Fabric: Polyester Double Knits, Nylon Tricot, Jersey, Stretch Terry, Spandex, Cire Tricot	11-BLUE (STRETCH FABRIC NEEDLE)	Polyester Core/Cotton Wrap 50 Mercerized Cotton	2-2.5 (10-12 stitches per inch)

• To Change the Needle

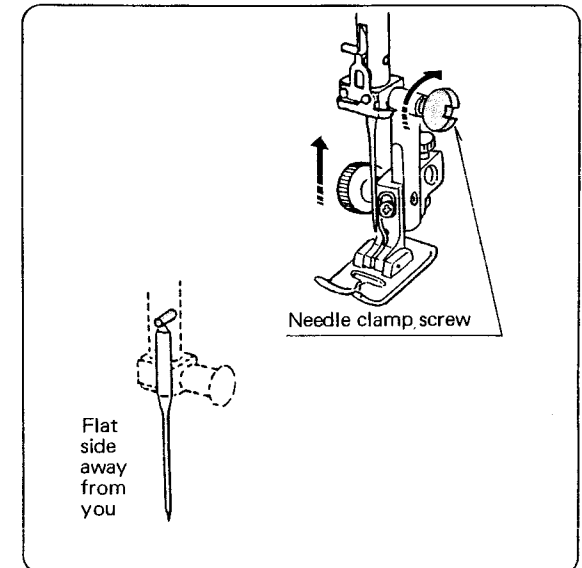

NOTE: Raise the needle bar to its highest position by turning the hand wheel toward you.

1. Loosen the needle clamp screw by turning it toward you.
2. Remove the needle by pulling it downward.
3. Insert the new needle into the needle clamp with the flat side away from you.
4. Push the needle up as far as it will go.
5. Tighten the needle clamp screw firmly with the large screwdriver from your accessory storage box.

SECTION 2. PREPARE THE MACHINE FOR SEWING

Prepare the Bobbin

- To Remove the Bobbin from the Machine

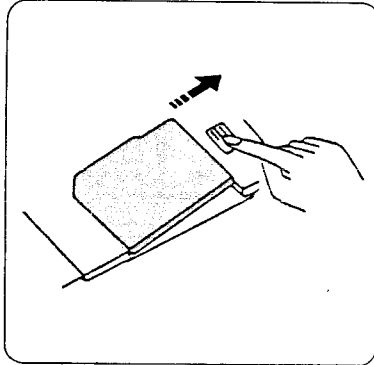

① Remove the cover plate by sliding the hook cover plate release button to the right.

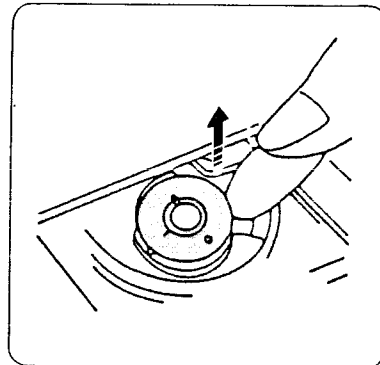

② Take out the bobbin.

- Horizontal Spool Pin

Ordinary Spool

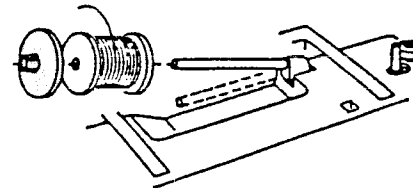

Small Spool

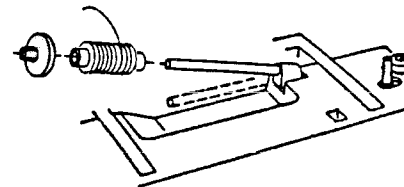

Tilt up the spool pin. Place the spool of thread on the spool pin with the thread coming off the spool as shown.

Attach the large spool holder pressing it firmly against the thread spool.

- The small spool holder is used with narrow or small thread spools.

- Additional Spool Pin

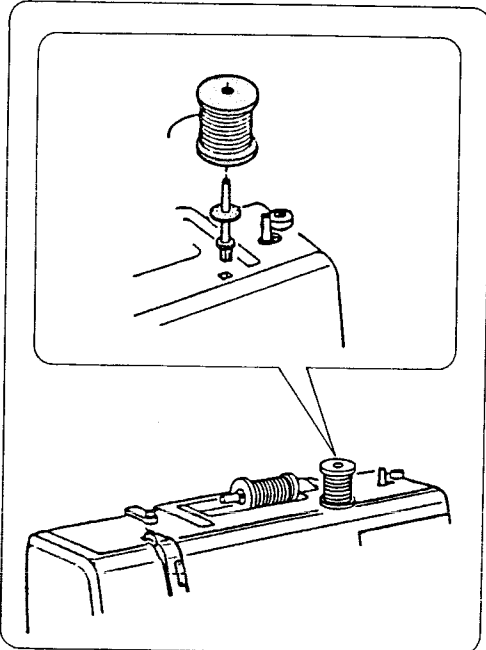

The additional spool pin is used to wind extra bobbins without unthreading the machine.

To use, insert the additional spool pin in the hole. Place the felt and the spool on the pin.

• Bobbin Winding

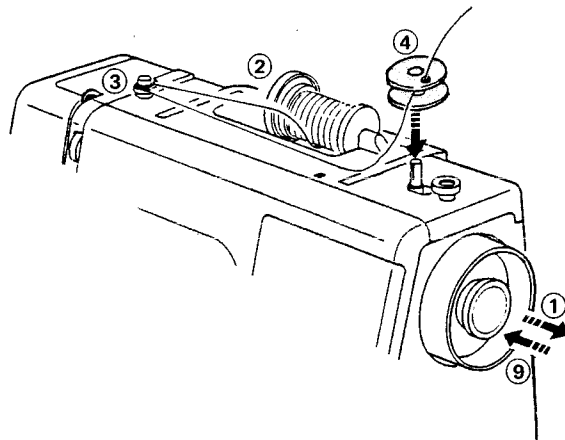
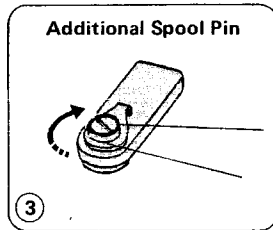
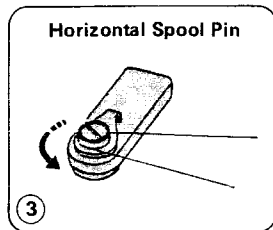

- ① Pull the clutch knob away from the machine to disengage clutch.
- ② Draw the thread from the spool.
- ③ Guide the thread around the bobbin winder thread guide.
- ④ Insert the thread through the hole in the bobbin, threading from the inside to the outside.
- ⑤ Put the bobbin on the bobbin winding spindle, and push it to the right.
- ⑥ With the free end of the thread held in your hand, depress the foot control.
- ⑦ Stop the machine when it has made a few turns, and cut the thread close to the hole in the bobbin. Depress the foot control again. When the bobbin is fully wound, it will stop automatically.
- ⑧ Return the bobbin winder to its original position by moving the spindle to the left, and cut the thread as shown.
- ⑨ Push in the clutch knob to engage clutch.

* The machine will not sew until the clutch knob is pushed in.

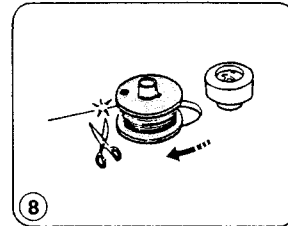
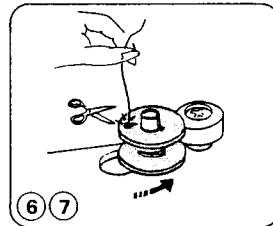
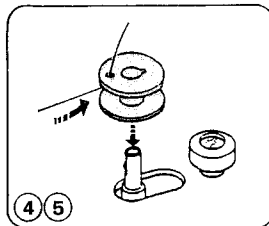

SECTION 2. PREPARE THE MACHINE FOR SEWING

• Insert the Bobbin into the Bobbin Holder

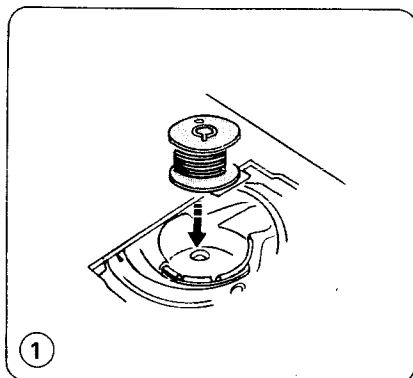

1. Put the bobbin into the bobbin holder so that the thread feeds counter-clockwise (left).

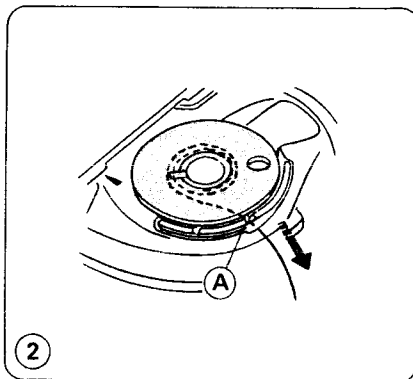

2. Pull about 4 inches of thread toward you through the tension slot **(A)**.

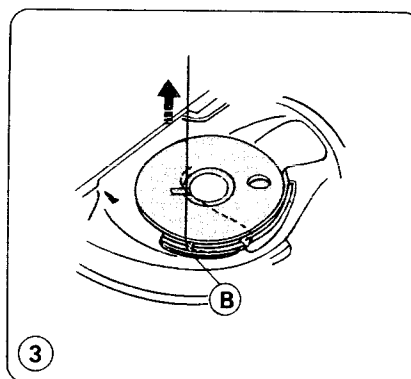

3. Then pull the thread clockwise toward the back of the machine through the slot **(B)**.

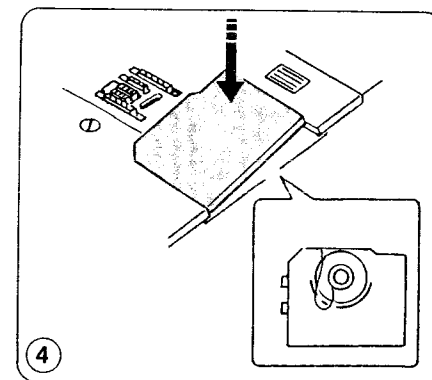

4. Pull out about 15 cm (6") of thread and attach the hook cover plate.

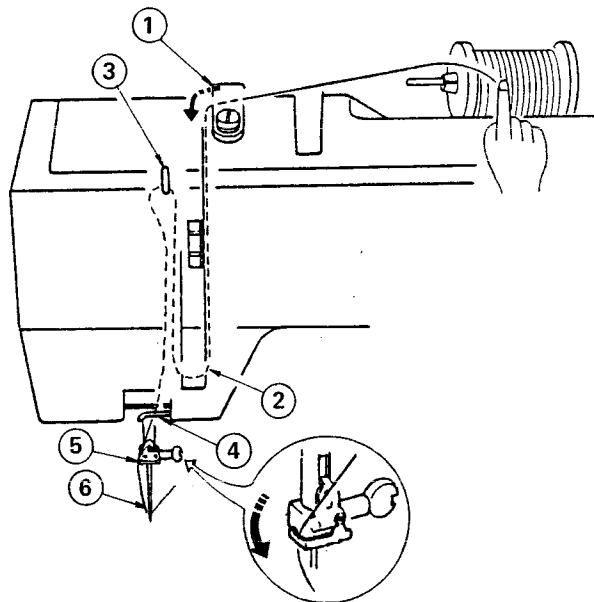
Prepare the Top Thread• **Thread the Needle**

The numbered steps above follow the numbers on the illustrations.

Dotted lines show places where the thread loops and then is pulled tight.

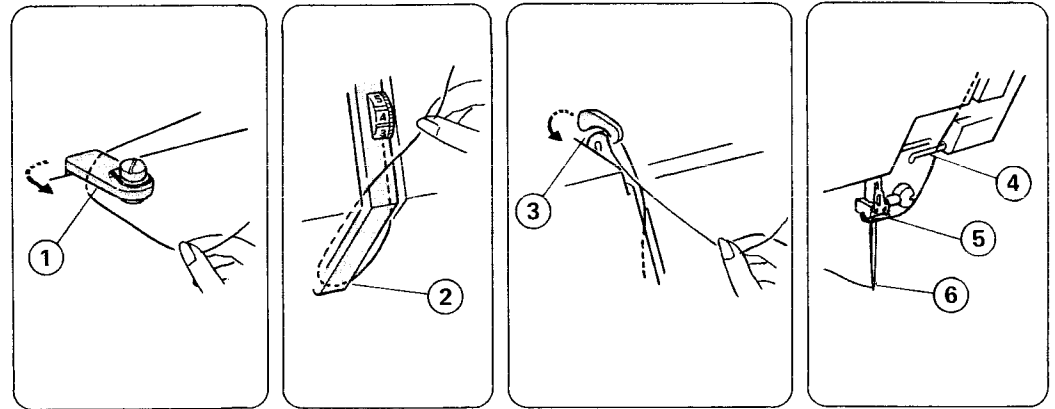

Raise the take-up lever to its highest position by turning the hand wheel toward you.

Raise the presser foot lever.

Place the spool on the spool pin as shown, with thread coming from the back of the spool.

1. Draw thread into thread guide using both hands.
2. While holding thread near spool, draw thread down into the tension area and then around the check spring holder.
3. Firmly draw thread up and through take-up lever from right to left.
4. Draw thread down and slip it through the thread guide.
5. Thread then is slipped into needle bar thread guide.
6. Thread needle from front to back.

NOTE: Cut the end of the thread with sharp scissors for easier needle threading.:

SECTION 2. PREPARE THE MACHINE FOR SEWING

Prepare the Top Thread (Continued)

- Pick Up the Bobbin Thread

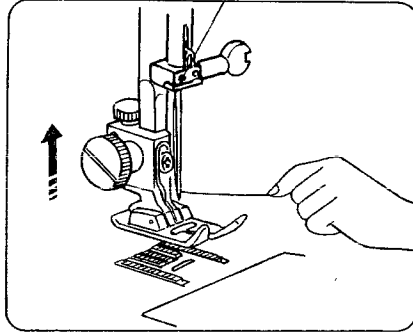

1. Raise presser foot lever. Hold needle thread loosely in left hand and rotate hand wheel toward you one complete turn.

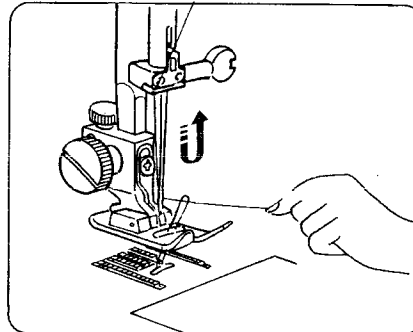

2. Bring bobbin thread up by pulling top thread.

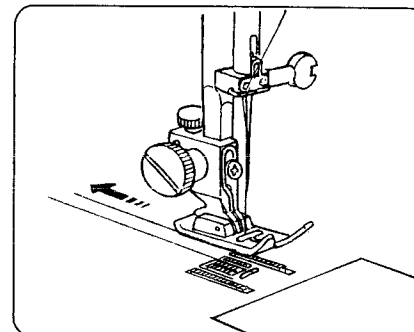

3. Pull both threads under and to the back of the presser foot, leaving 4 to 6 inches of thread clear.

• Adjust the Top Thread Tension

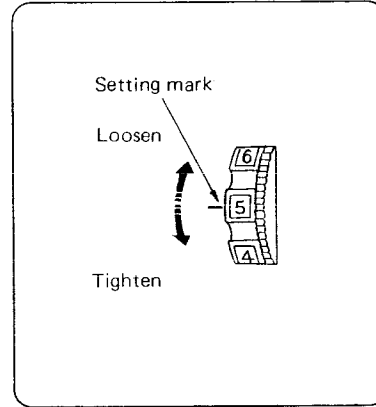
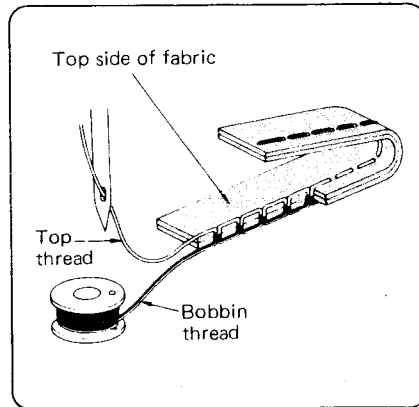

For Straight Stitch

The ideal straight stitch will have threads locked between the two layers of fabric, as shown above, magnified to show detail.

If you look at the stitch, front and back, you will notice that there are no gaps, that each stitch is smooth and even.

When adjusting top thread tension, the higher the number, the tighter the top thread.

Choose the Correct Tension:

The best tension will depend on;

- _____ the stiffness and thickness of the fabric
- _____ the number of fabric layers
- _____ the type of stitch

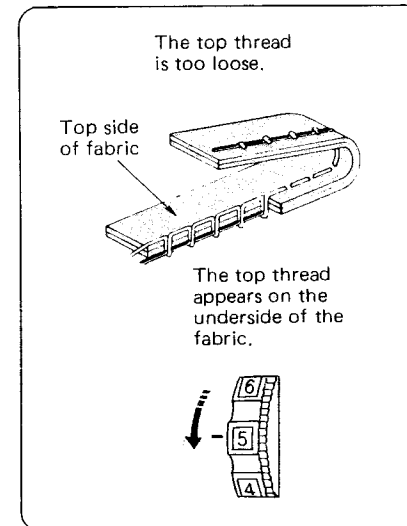

Tension is too loose:

The top thread shows through the bottom of the fabric. The bottom side of the stitch will feel bumpy.

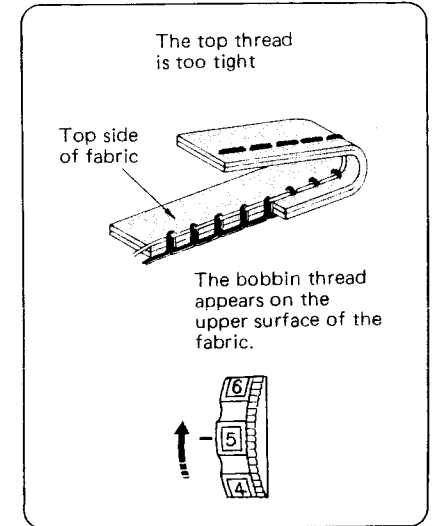

Tension is too tight:

The bobbin thread will come through the top of the fabric. The top side of the stitch will feel bumpy.

SECTION 2. PREPARE THE MACHINE FOR SEWING

Prepare the Top Thread (Continued)

For Zigzag Stitch

In the correct zigzag stitch, the bobbin threads will not show on the top side of fabric and the top threads will show slightly on the bottom side. See below for the correct appearance. To match this appearance, adjust the top tension.

Top tension

Too Tight

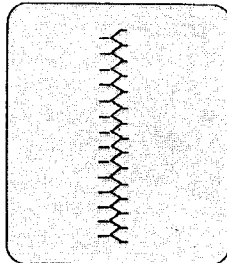

Top side of Fabric

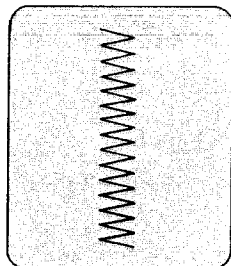

Bottom side of Fabric

Too Tight:

— Corner of each zigzag will pull together on the top side of fabrics.

Top tension

Too Loose

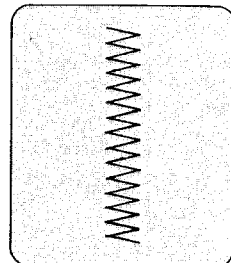

Top side of Fabric

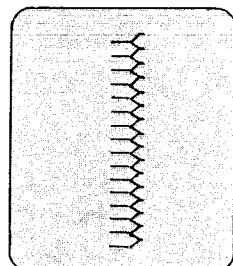

Bottom side of Fabric

Too Loose:

— The top thread will loop through bottom side of fabric and will be pulled almost together.

Just Right

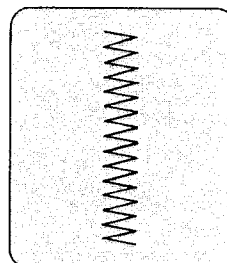

Top side of Fabric

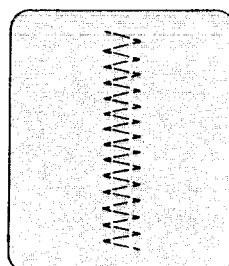

Bottom side of Fabric

Just Right:

Minimize the amount of top thread visible on the bottom side of fabric without causing excessive puckering or causing the bobbin thread to show on the top side. Results vary with fabric, thread and sewing conditions.

Stitch Selector

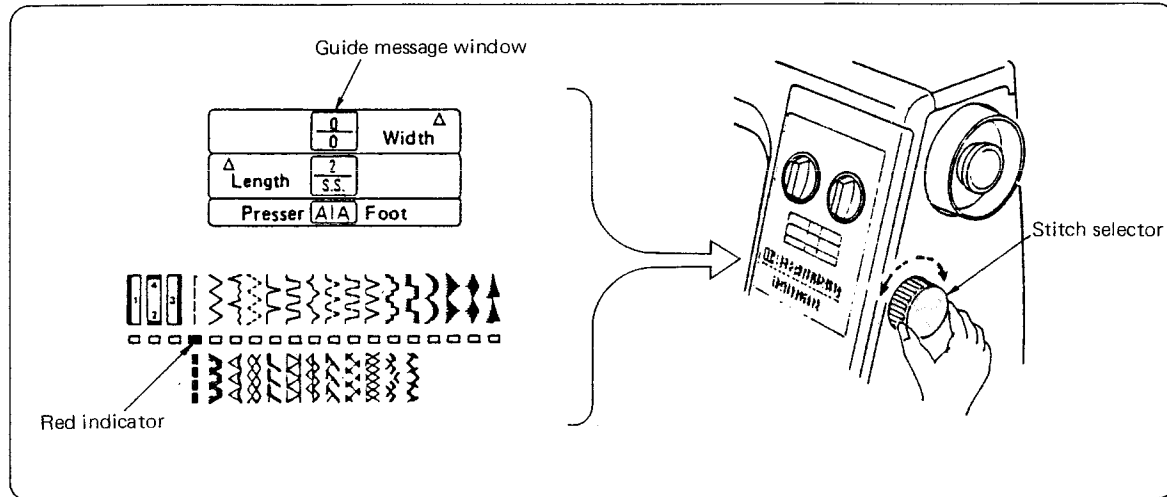

The stitch selector control determines the stitch you select.

Simply turn this control until the desired stitch is indicated by the red indicator on the stitch indicator panel. The bottom row of stitches is selected when the stitch length control is set at the stretch stitch position.

Suitable width, stitch length and foot are shown in the guide message window.

When you select the desired stitch by turning the stitch selector, the information in the window will change automatically.

Please use the colour in the guide window which corresponds to the colour of the stitch you select.

NOTE: To avoid needle or fabric damage, be sure your needle is up and out of fabric when selecting a stitch.

SECTION 2. PREPARE THE MACHINE FOR SEWING

Stitch Width Control

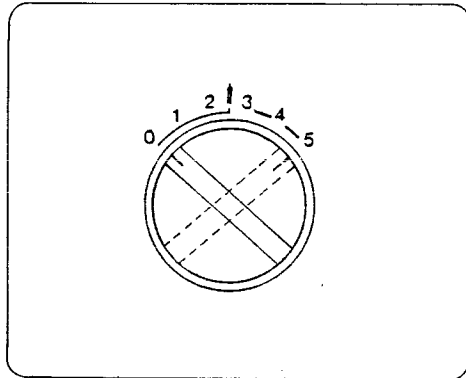

The stitch width control regulates the width of the stitch you select.

The higher the number, the wider the stitch.

The "↑" is the maximum width for twin needle stitches.

The blue zone is adjustable area for button hole stitches.

Stitch Length Control

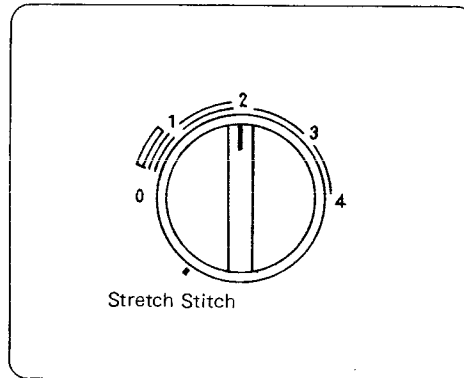

The stitch length control regulates the length of stitch, and also has a stretch stitch setting.

The higher the number, the longer the stitch.

0 means no feed.

To select the Stretch Stitches, set this control at Stretch Stitch.

NOTE: When you select decorative stitches (green) or built-in buttonhole (blue), make sure that you do not set the stitch length control at "Stretch Stitch".

Study the red, green, brown and blue sections around this control. These are recommended zones of stitch length and are color-coded to the stitches pictured on the stitch indicator panel.

Adjusting Stretch Stitch Balance

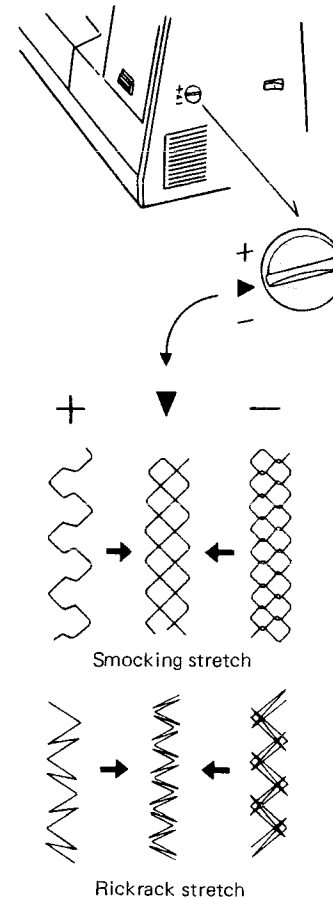

In stretch stitch sewing, the stretch stitch adjuster should usually be in a neutral position ▽ or between "+" and "-" position. When sewing some fabrics, you may need to adjust this control to balance the stitches for appearance sake.

If the design seems open like the illustrations to the left, adjust the control slightly toward "-" until it looks like the center design.

If the design appears to be closed as in the right hand illustrations, turn the control toward "+" until stitching is as you desire.

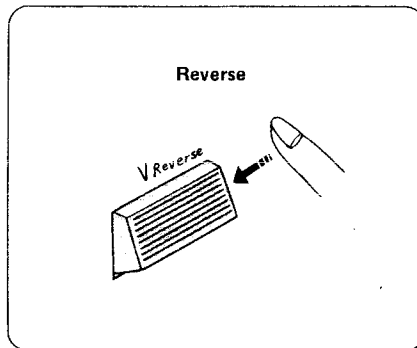
Reverse Stitch Control

To reverse stitch, hold down this control during sewing.

Release to sew forward again.











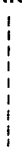





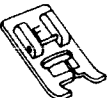

Starting To Sew

Now that you are familiar with the controls on your machine and with the accessories provided for the machine, you are ready to start to sew with your new Kenmore sewing machine. Below are some good habits to follow each time you sit down to sew:



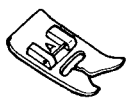





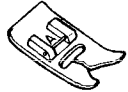

1. Inspect the needle. It should be straight, properly set and sharp on the point. It should be the correct size for the fabric and thread being used. Do not be afraid to change your needle frequently. Many of the new fabrics made of synthetic blends tend to dull the needles more easily than fabrics made of natural fibers.
2. Before placing the material on the machine, see that the ends of the threads have been drawn about 4 inches to the rear of the machine. Hold on to threads during the sewing of the first 3 or 4 stitches of the seam.
3. Test the machine stitch on a scrap of the fabric you plan to use. The fabric should be double thickness. Adjust the machine for the length of stitch and tension suitable to the fabric.
4. Fabric should be placed under the presser foot with the bulk of the material to the left of the needle and the right edge of the material placed on the 5/8" seam marking on the needle plate when making a simple seam.
5. Run the machine at a slow even speed. The more pressure you put on the foot control, the faster the machine will sew.
6. Fasten each seam by back tacking sewing a few stitches in reverse.
7. Always finish sewing each seam with the needle at its highest point.
8. Guide the fabric gently with your hand in front of the needle. Never pull or hold the fabric in such a way that the normal feeding is altered.
9. When turning the hand wheel manually, always turn it toward you.

SECTION 3 LEARN THE STITCHES

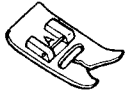
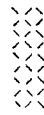
Practical Stitch Chart

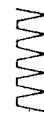

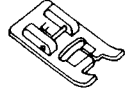
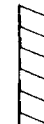

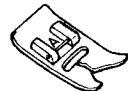







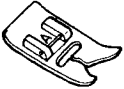

Stitch	Stitch Selection	Foot and Other Attach.	Needle	Thread Tension	Stitch Length	Stitch Width	Uses	Refer to Page
STRAIGHT 		Straight  Zigzag  Zipper foot 	Check Chart on p. <u>15</u>	2 ~ 6	Red Zone	0	Regular seams, zippers, topstitching, quilting darning, etc.	31
STRAIGHT STRETCH 		Straight  or 	Check Chart on p. <u>15</u>	2 ~ 6	Brown Stretch Stitch Position	0	Use on knits and other stretch fabrics, good for topstitching.	49
ZIGZAG 		Satin  Zigzag  or	Check Chart on p. <u>15</u>	3 ~ 8	Red Zone	1 ~ 5	Finish edges, buttons, satin stitch, applique, monogram, embroidery, sewing bar tacks.	36
RICK-RACK STRETCH 		Zigzag 	Check Chart on p. <u>15</u>	2 ~ 6	Brown Stretch Stitch Position	2 ~ 5	Decorate garments with one row or several.	49
BLIND HEM STITCH 		Zigzag 	Check Chart on p. <u>15</u>	2 ~ 6	Red Zone	2 ~ 3	Use for finishing seams and hemming.	42

SECTION 3. LEARN THE STITCHES









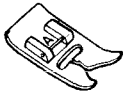

Stitch	Stitch Selection	Foot and Other Attach.	Needle	Thread Tension	Stitch Length	Stitch Width	Uses	Refer to Page
OVERCAST STRETCH 		Zigzag 	Check Chart on p. <u>15</u>	2 ~ 6	Brown Stretch Stitch Position	3 ~ 5	Use for swimwear, ski pants and other garments that require stretch.	41
THREE-STEP ZIGZAG 		Zigzag 	Check Chart on p. <u>15</u>	2 ~ 6	0.5 ~ 1	5	Use for finishing seams. Use for mending.	44
SMOCKING STITCH 		Zigzag 	Check Chart on p. <u>15</u>	2 ~ 6	Brown Stretch Stitch Position	3 ~ 5	Use in smocking or as a decorative stitch.	50
SHELL STITCH 		Satin 	Check Chart on p. <u>15</u>	4 ~ 9	Red Zone	3 ~ 5	Finish hems, sleeve and neck openings. Use on nylon tricot and other lingerie to overcast and seam. Do shell tucking on blouses and lingerie.	45
SERGING 		Zigzag 	Blue (11) on p. <u>15</u>	3 ~ 6	Brown Stretch Stitch Position	3 ~ 5	Finish hems, sleeve and neck openings. Use on nylon tricot and other lingerie to overcast and seam. Do shell tucking on blouses and lingerie.	51

SECTION 3. LEARN THE STITCHES

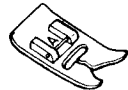
Practical Stitch Chart (Continued)

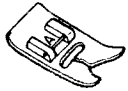

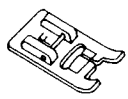

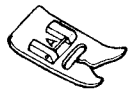

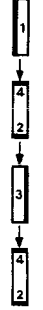
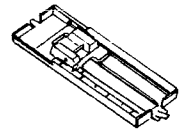
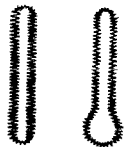

Stitch	Stitch Selection	Foot and Other Attach.	Needle	Thread Tension	Stitch Length	Stitch Width	Uses	Refer to Page
BOX STITCHING 		Zigzag 	Check Chart on p. <u>15</u>	3 ~ 8	Red Zone	3 ~ 5	Use for overlapping seams.	45
ELASTIC STRETCH 		Zigzag 	Check Chart on p. <u>15</u>	3 ~ 6	Brown Stretch Stitch Position	3 ~ 5	Use for applying elastic.	51
FAGOTING 		Zigzag 	Check Chart on p. <u>15</u>	3 ~ 8	0.5 ~ 2	5	Join two folded edges for decorative open-work appearance.	46
STRETCH PATCHING 		Zigzag 	Check Chart on p. <u>15</u>	2 ~ 6	Brown Stretch Stitch Position	5	Use for patchwork quilting and patching.	52
TWO-POINT SHELL STITCHING 		Zigzag 	Check Chart on p. <u>15</u>	3 ~ 8	Red Zone	3 ~ 5	Do shell tucking on blouses and lingerie. This stitch can also be used as a single overlock stitch.	46

SECTION 3. LEARN THE STITCHES

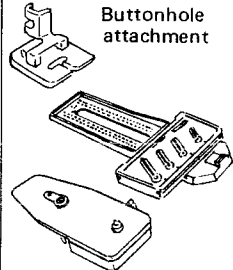
Stitch	Stitch Selection	Foot and Other Attach.	Needle	Thread Tension	Stitch Length	Stitch Width	Uses	Refer to Page
HERRING BONE STRETCH 		Zigzag 	Check Chart on p. <u>15</u>	2 ~ 6	Brown Stretch Stitch Position	3 ~ 5	Use as hemming stitch for blankets, tablecloth and draperies.	52
TWO-POINT BOX STITCH 		Zigzag 	Check Chart on p. <u>15</u>	3 ~ 8	Red Zone	3 ~ 5	Use for overlapping seams.	47
OVEREDGE STITCH 		Zigzag 	Check Chart on p. <u>15</u>	3 ~ 8	Red Zone	3 ~ 5	Use for overedging.	47
DECORATIVE GEOMETRICS		Satin 	Check Chart on p. <u>15</u>	3 ~ 8	Green Zone	3 ~ 5	Decorate garments with one row or several, one stitch or a combination.	48
STRETCH STITCH DECORATIVE		Zigzag 	Check Chart on p. <u>15</u>	2 ~ 6	Brown Stretch Stitch Position	3 ~ 5	Use in smocking or as a decorative stitch.	53

SECTION 3 LEARN THE STITCHES

Practical Stitch Chart (Continued)

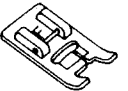
Stitch	Stitch Selection	Foot and Other Attach.	Needle	Thread Tension	Stitch Length	Stitch Width	Uses	Refer to Page
BUTTONHOLE 		Sliding buttonhole 	Check Chart on p. 15	2 ~ 6	Blue Zone	Blue Zone	Buttonholes: also corded buttonholes.	55
		Buttonhole attachment 	Check Chart on p. 15	2 ~ 6	4	2	Round end buttonholes and keyhole buttonholes.	57
TWIN NEEDLE STITCHES		Zigzag  or Satin 	Twin Needle	3 ~ 7	Brown Stretch Stitch Position or Green Zone		Use for sewing parallel rows of straight or decorative stitches adding an exquisite touch to table linen and clothing.	61
SATIN STITCH 		Satin 	Check Chart on p. 15	3 ~ 8	0.5 ~ 1	2 ~ 5	Use for applique work, also as a decorative finish for placemats, blankets, collars, cuffs and pockets.	37

Straight Stitches

• Straight Stitch

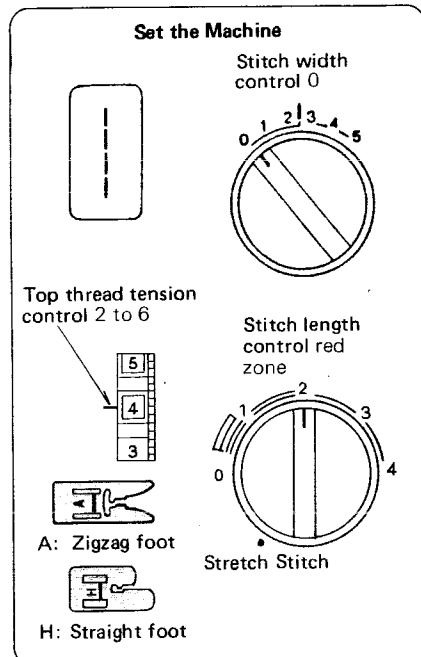

NOTE: Best sewing results are obtained with the straight stitch foot, but the zigzag foot will also provide acceptable results.

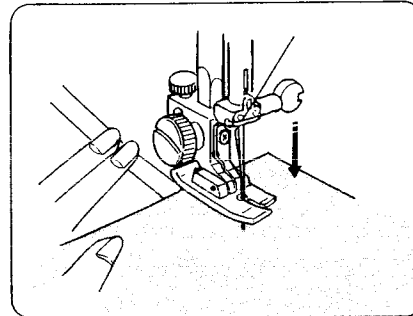

Before sewing with the straight stitch foot, always set the stitch width control to 0 to avoid breaking the needle.

1. Raise the presser foot.
2. Raise the needle to its highest position.
3. Place the edge of the fabric next to a stitching guide line on the needle plate (5/8" is most common).
4. Draw the threads toward the back and lower the presser foot.
5. Press the foot control.
6. Hold the fabric loosely and gently guide it along the guide line, so that it feeds naturally.

Do not force the fabric or try to pull it tight.

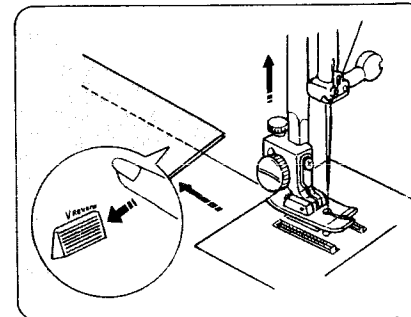

7. At the beginning and end of the seam, you may want to reverse to lock the stitch.
8. Raise the presser foot and remove the fabric.
9. Cut the threads.

• Use the Seam Guides

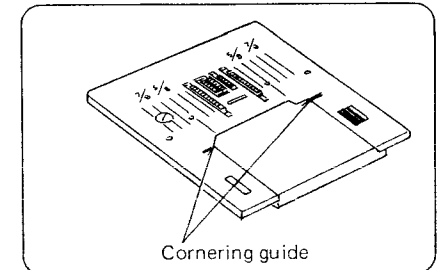

The seam guides on the needle plate are engraved to help you measure seam width. The lines are 1/8" apart, with the 5/8" and 7/8" lines marked.

• Turn a Square Corner

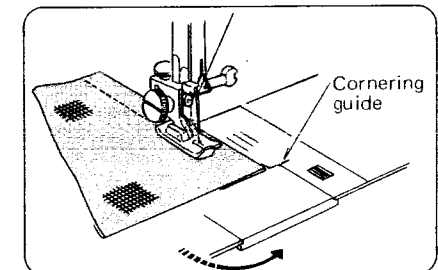

To turn a square corner 5/8" from the fabric edge:

1. Stop stitching and lower the needle by turning hand wheel toward you when the fabric edge facing you lines up with the cornering guide, as shown.
2. Raise the presser foot and turn the fabric to line the edge with the 5/8" seam guide.
3. Lower the presser foot and begin stitching in the new direction.

SECTION 3. LEARN THE STITCHES

Straight Stitches (Continued)

• Dropping the Feed Dogs

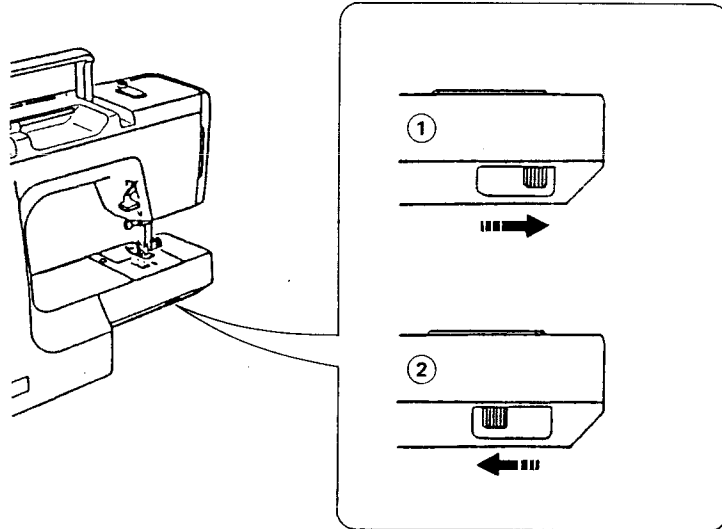

The drop feed lever is located underneath the free arm bed on the back side of the machine.

- ① To raise the feed dogs, push the lever in the direction of the arrow as illustrated. Then turn the handwheel.
- ② For dropping the feed dogs, push the lever in the direction of the arrow as illustrated.

* Feed dogs must always be up for normal sewing.

• Darning

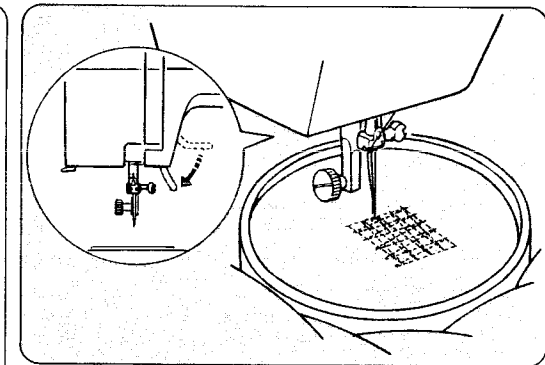
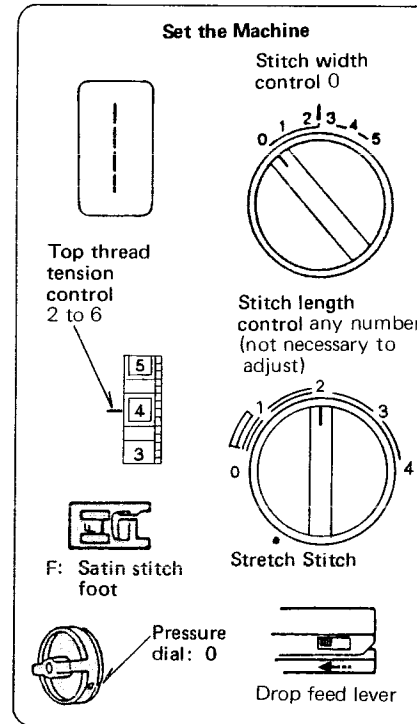

1. Drop the feed dogs.
2. Stretch the fabric with the hole in the center between embroidery hoops, as shown.
3. Lower the presser bar and sew at a slow speed.
4. Move the fabric back and forth slowly until you have covered the darning area.
5. Turn the fabric 1/4 turn and sew another layer of stitching over the first layer.

NOTE: If your fabric is thin or badly damaged use a separate piece of fabric under the hole to reinforce it.

6. When you finish darning, return the pressure dial to 3.

- Topstitching

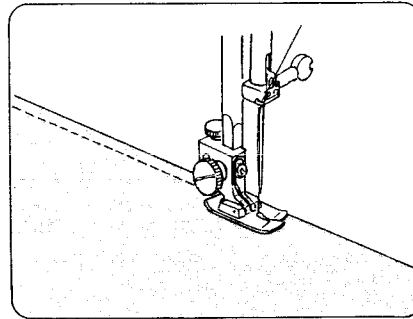
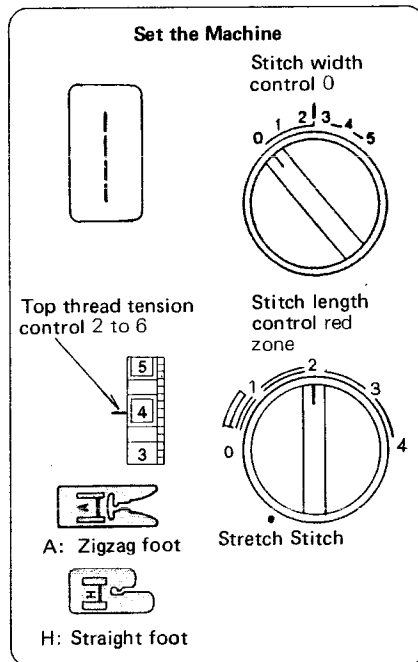

Here's How

1. Lower the presser foot.
2. Keep the edge of the fabric next to the right edge of the presser foot.
3. Guide the fabric evenly along this edge to produce an even row of topstitching 5/8" from the edge.

The Stitch and Its Uses

Topstitching emphasizes the lines of your garment and keeps seams and edges flat and crisp.

Accent suits or blouses with one or two rows of topstitching around the outer edges of cuffs, lapels or collars.

SECTION 3 LEARN THE STITCHES

Straight Stitches (Continued)

• Sew in a Zipper

Fabric Preparation:

Put the top sides of the fabric together and sew to the end of the zipper opening. Use the reverse to lock the stitches.

Sew the zipper opening with stitch length at "4" and top thread tension at "3".

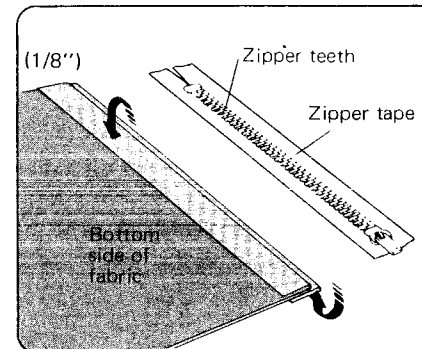
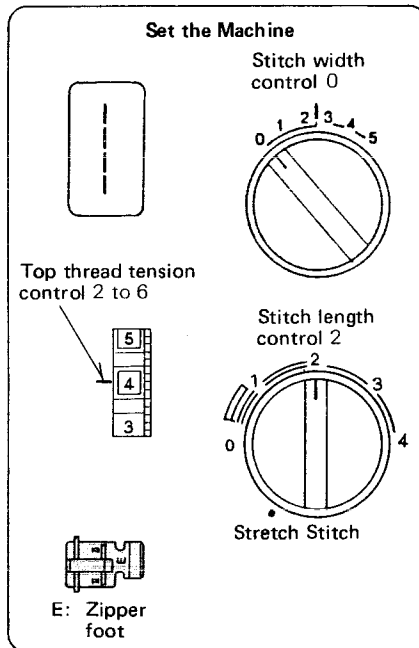
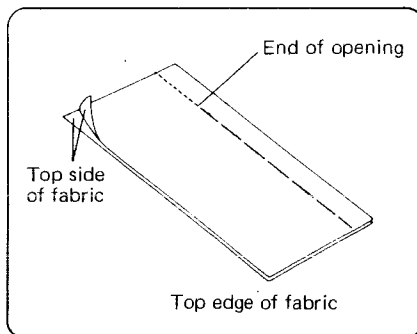

To Sew:

1. Reset stitch length at 2 and top thread tension at 2 to 6. Fold back the left seam allowance as shown.
2. Turn under the right seam allowance to form a 1/8" fold.
3. Place the zipper teeth next to the 1/8" fold and pin in place.

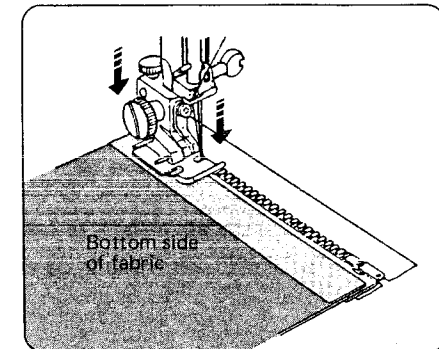

4. Attach the presser bar to the right pins on the zipper foot.
5. Lower the zipper foot on the top side at the bottom of the zipper so that the needle pierces the fold and the zipper tape.
6. Sew through the fold and the zipper tape to the point where the slider begins.
7. Lower the needle to hold the fabric and raise the presser foot.

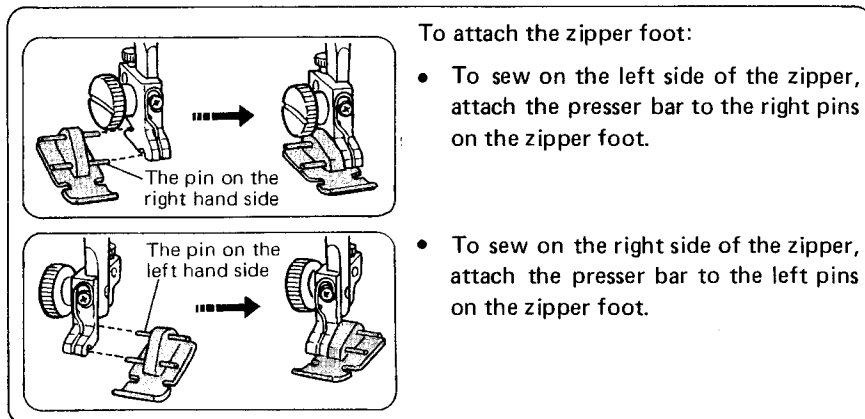

To attach the zipper foot:

- To sew on the left side of the zipper, attach the presser bar to the right pins on the zipper foot.
- To sew on the right side of the zipper, attach the presser bar to the left pins on the zipper foot.

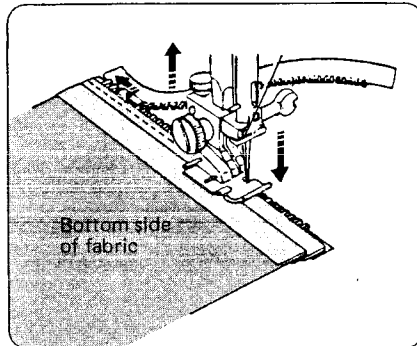

8. Open the zipper.
9. Lower the presser foot and stitch the rest of the seam.

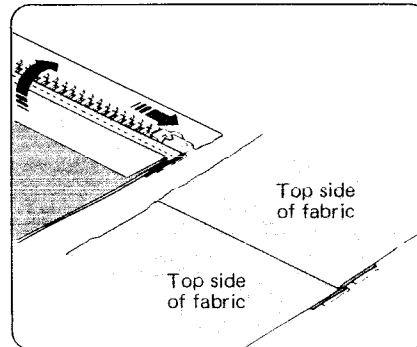

10. Close the zipper and turn the fabric top side up.

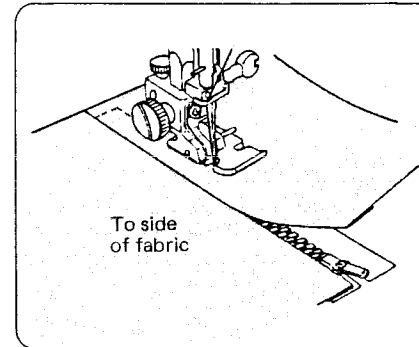

11. Remove the zipper foot and attach the presser bar to the left pins on the zipper foot.
12. Stitch across and below the bottom of the zipper.
13. Turn the corner and continue to guide the foot along the zipper teeth, as shown. Stitch through the fabric and zipper tape.

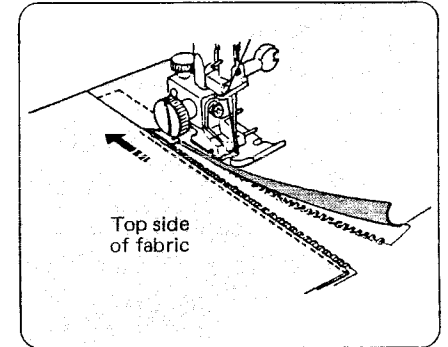

14. Stop about 2" from the top of the zipper.
15. Lower the needle into the fabric and raise the presser foot.
16. Remove the basting stitches and open the zipper.
17. Lower the foot and stitch the rest of the seam. Make sure the fold is even.

Zigzag Stitches

• **Basic Zigzag**

Set the Machine



Stitch width control 1 to 5

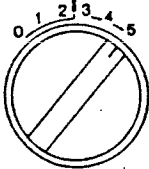

Top thread tension control 3 to 8

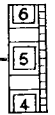

Stitch length control red zone

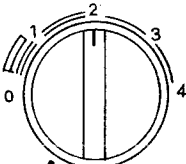

Stretch Stitch

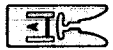

A: Zigzag foot

The Stitch and Its Uses

The zigzag stitch is one of the most common and most versatile stitches on your machine. It can be a utility stitch for sewing buttons, buttonholes, hemming, overcasting, mending and darning. It can also be used to decorate with trims, appliques and cut-out work or as a decorative stitch.

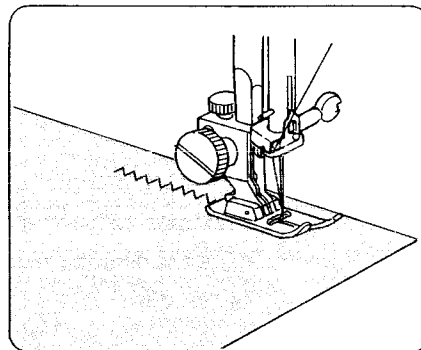

Here's How

There are many ways to sew a zigzag stitch.

Consult the specific variations for detailed directions.

- Satin Stitch page 37,
- Applique Work page 38,
- Bar Tacking page 38,
- Monogramming page 36,
- Embroidery page 39,
- Button Sewing page 40,
- Overcasting page 41.

• **Monogramming**

Set the Machine



Stitch width control 5

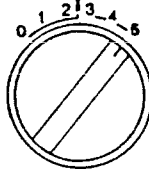

Top thread tension control 2 to 6

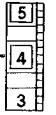

Stitch length control 0.5 to 1

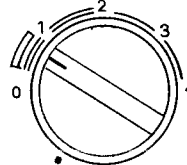

Stretch Stitch



F: Satin stitch foot

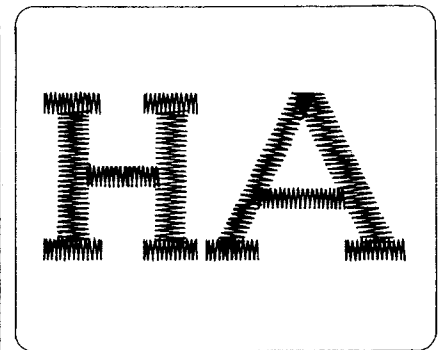

Here's How

1. Set the same as satin stitch.
2. Back the fabric with paper or interfacing.
3. Draw the letters on the fabric with tailor's chalk.
4. Satin stitch, adjusting the stitch width as necessary to form each pattern.
5. If using paper, carefully remove it when you have finished sewing.

• Satin Stitch

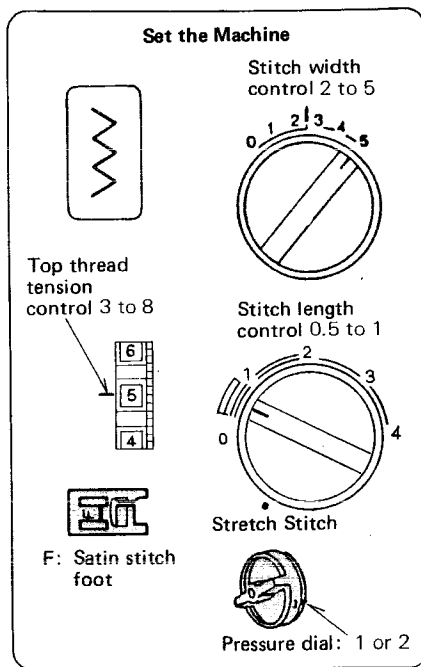

The Stitch and Its Uses

The Satin stitch is a versatile and often used decorative stitch, but it can also be used to overcast a raw edge (for example, blankets, linens, tablecloths and napkins).

The Satin stitch is especially attractive in applique.

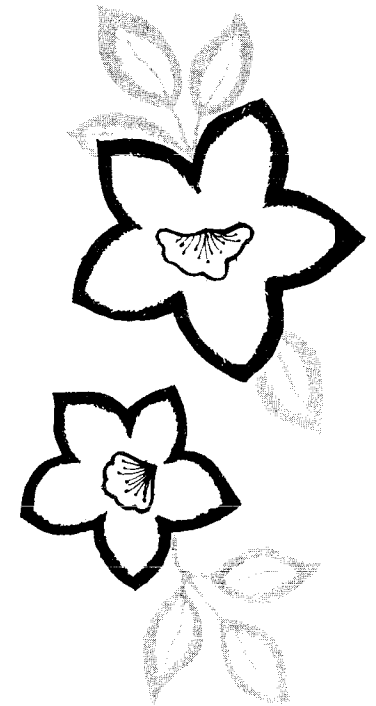
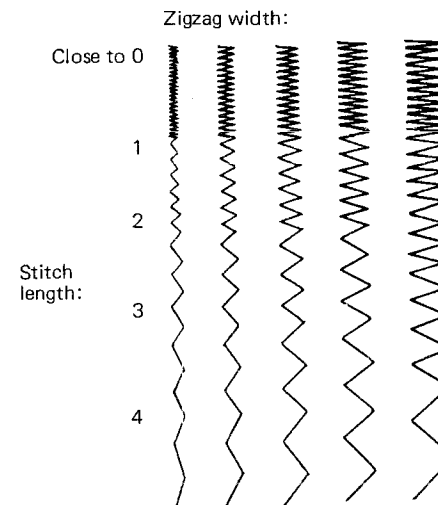

Here's How

Once your machine is set up to stitch, you may want to experiment on a scrap of the fabric you are planning to use. Too tight a satin stitch may pucker some lightweight fabrics.

SECTION 3 LEARN THE STITCHES

Zigzag Stitches (Continued)

• Applique

Set the Machine



Stitch width control 2 to 5

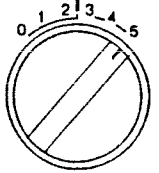

Stitch length control 0.5 to 1

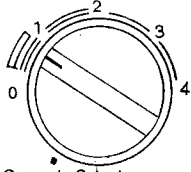

Top thread tension control 2 to 6

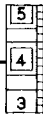

F: Satin stitch foot



Pressure dial: 2

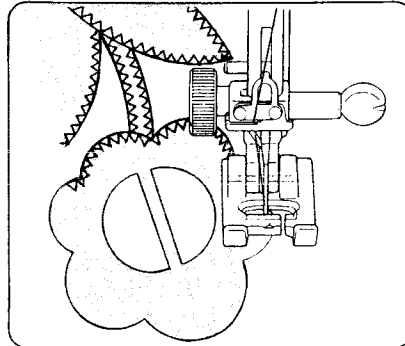



Baste (or fuse with iron-on fabric joiner) applique pieces on the fabric. Stitch around the applique making sure the needle falls along the outer edge of the applique.

When sewing corners, lower the needle down into the fabric. Raise the presser foot and pivot the fabric to the right or left.

• Bar Tacking

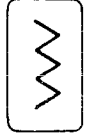
Set the Machine



Stitch width control 2 to 5

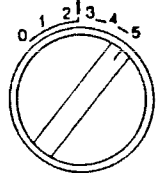

Stitch length control 0.5 to 1

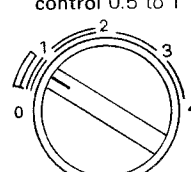

Top thread tension control 2 to 6

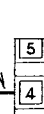

A: Zigzag foot

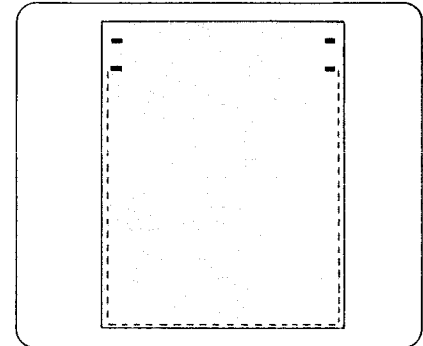
This stitch is similar to a very short satin stitch and is used to reinforce points of strain such as corners or pockets and straps on lingerie.

Sew 4 to 6 zigzag stitches.

• Embroidery

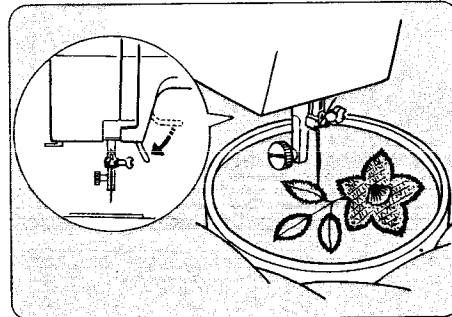
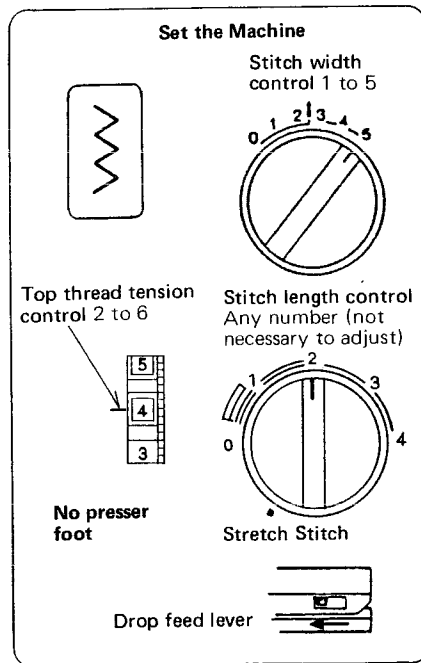

Here's How

1. Drop the feed dogs (see page [32](#)).
2. Remove foot holder (see page [11](#)).
3. Adjust the stitch width as desired (see page [24](#)).
4. Draw the design on to the fabric with tailor's chalk.
5. Stretch the fabric between embroidery hoops and place under the needle.
6. Lower the presser foot lever to engaged the top thread tension.
7. Holding the top thread in your left hand, rotate the hand wheel toward you one complete turn. Pull the top thread to draw the bobbin thread through to the surface of the fabric.
8. Using a medium speed, stitch along the marked outline, guiding the fabric carefully by hand.
9. When finished embroidering, raise the feed dogs (see page [32](#)).

Zigzag Stitches (Continued)

• Sew a Button

Set the Machine



Stitch width control
Must be adjusted

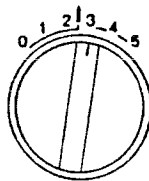

Top thread tension
control 2 to 6

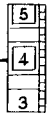

Stitch length control
Any number (not
necessary to adjust)

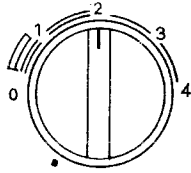

A: Zigzag foot



Drop feed lever

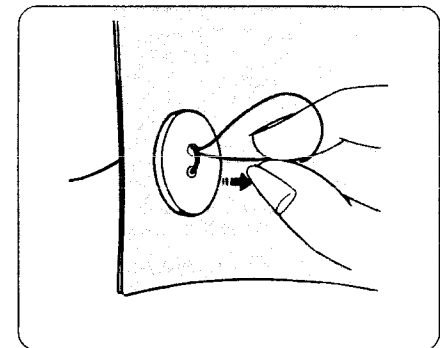
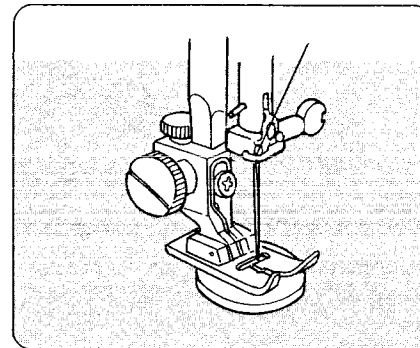
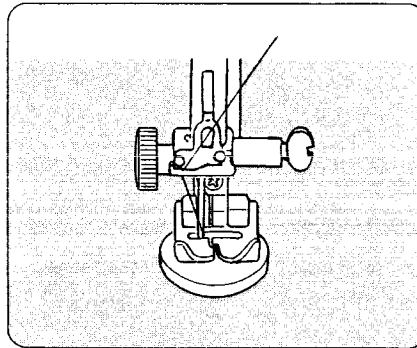

Stretch Stitch

Drop the feed dogs (see page 32).

1. Match the center of the button holes to the center of the slot on the presser foot.
2. Adjust the stitch width so that needle will drop in each hole.
3. Lower the foot to hold the button in place.
Turn the hand wheel by hand so that needle will enter either hole of the button.
4. Stitch several times.

To strengthen the shank, cut the threads leaving a 8" tail. Bring the needle thread down through the hole in the button and wind it around the shank.

Draw the thread to the bottom side and knot.

When finished, raise the feed dogs (see page 32).

• Overcasting Stitch

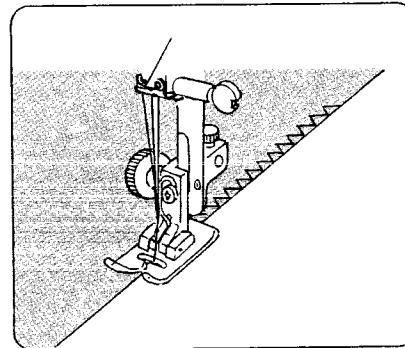
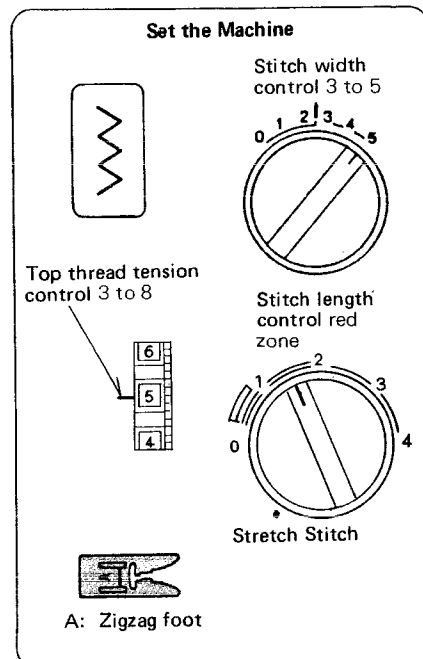

Helpful Hints

Start overcasting about 1/8" inside the raw corner of your seam. If you start right at the edge, the fabric will bunch up and the stitches will become tangled.

The Stitch and Its Uses

This zigzag variation is very useful in garment construction and in finishing raw edges of any sewing project.

Zigzag Stitches (Continued)

• **Blind Hemming**

Set the Machine



Stitch width control 2 to 3

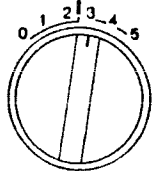

Top thread tension control 2 to 6



Stitch length control red zone

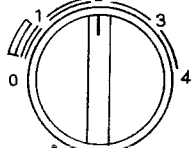

Stretch Stitch



A: Zigzag foot

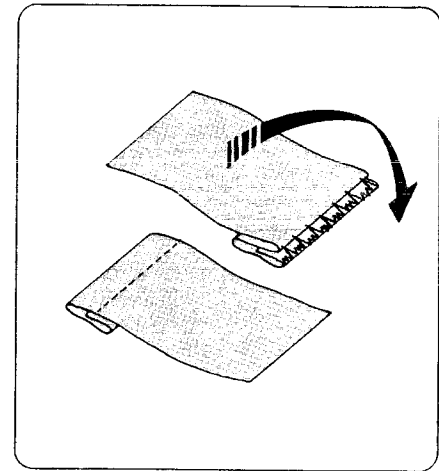
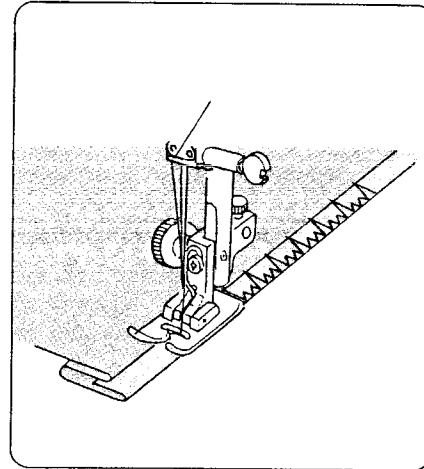
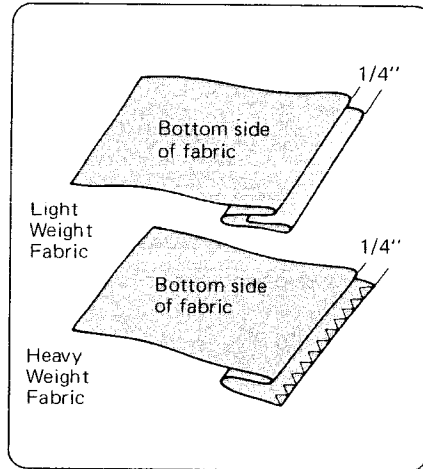

1. Finish the raw edge of your hem any way you desire (see overcasting page 41).

2. Measure, turn up your hem and pin.

NOTE: For light weight fabrics, you may need a double fold.

3. Fold the material (bottom side out) on the edge to be stitched, as shown, leaving 1/4" of the finished hem edge showing.

4. Place garment under presser foot in such a manner that narrow zigzag stitches will be sewn on extended edge. The wide zigzag stitch should just catch the fold of the garment.

5. After hemming, press both sides of the finished hem. The top side of the garment will show only the blind stitches.

- Lace Work

Set the Machine



Stitch width control 2 to 3

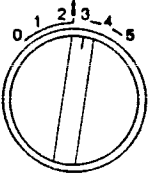

Top thread tension control 2 to 6



Stitch length control 1

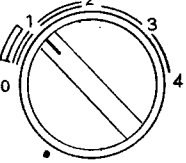

Stretch Stitch



A: Zigzag foot

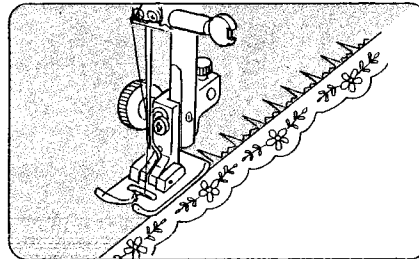
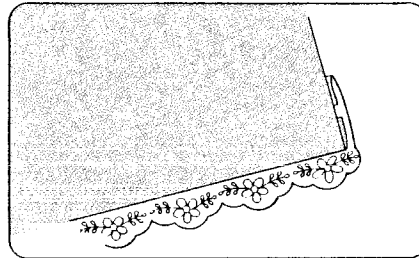

Lace adds a fanciful, feminine touch to blouses and lingerie. Table linens and pillows become more elegant when trimmed with lace.

Turn raw edge of fabric under at least $\frac{5}{8}$ ". Place lace underneath and top-stitch using blind hem stitch.

Trim excess fabric close to stitching.

Zigzag Stitches (Continued)

• Three-Step Zigzag

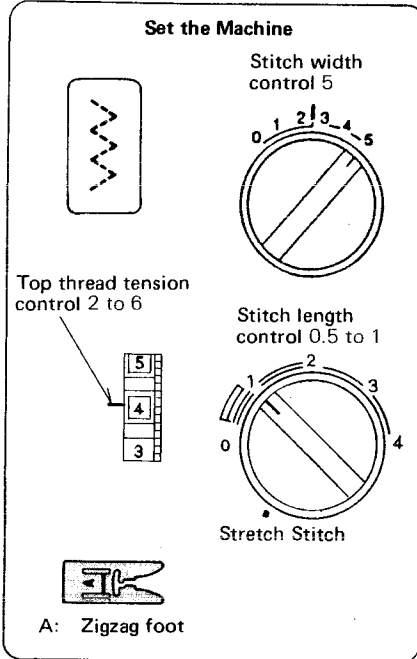

The Stitch and Its Uses

The three-step zigzag is a combination zigzag and straight stitch. You may use the three-step zigzag everywhere you would use the basic zigzag stitch. It has more strength, elasticity, and is flatter than a regular zigzag.

The three-step zigzag stitch is especially useful for:

- mending
- sewing patches smoothly and securely
- repairing straight tears
- finishing seams

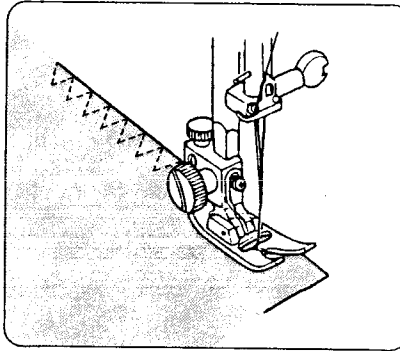

Seam Finishing (Overcasting)

Place the fabric under the presser foot so that the edge will be slightly inside the right hand side of the presser foot.

Guide the work so the right-hand stitches fall at the edge of the fabric.

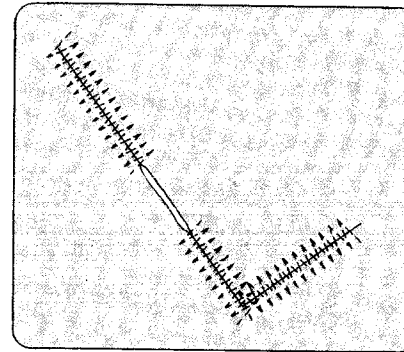

Mending

Position the tear under the needle so that the stitching will catch both sides.

• Shell Stitching

Set the Machine

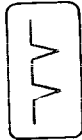

Stitch width control 3 to 5

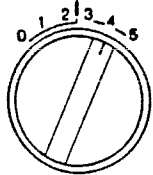

Top thread tension control 4 to 9

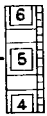

Stitch length control red zone

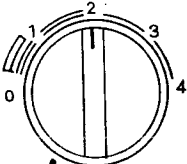

Stretch Stitch



F: Satin stitch foot

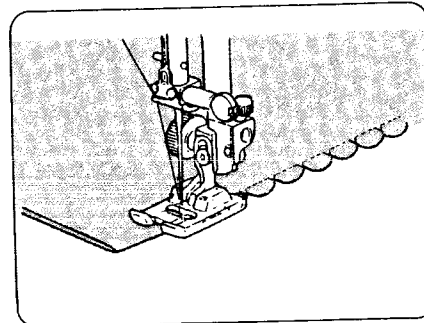

Here's How

1. For best effect:
 - set the stitch length as you desire.
 - you may need to tighten the top thread tension slightly.
 - allow the needle to just clear the folded edge of the fabric when it zigzags.

2. If you sew rows of shell stitches, space the rows 5/8" apart.

You can sew Shell Stitch on knits or soft silky wovens in any direction.

The Stitch and Its Uses

The Shell Stitch is formed by sewing a blind hem over folded fabric. Several rows of shell stitching are called shell tucks.

Shell stitching can be used to finish hems, sleeve and neck openings.

Shell tucking can be used to create scalloped tucks on blouses and lingerie.

• Box Stitching

Set the Machine



Stitch width control 3 to 5

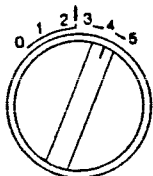

Top thread tension control 3 to 8



Stitch length control red zone

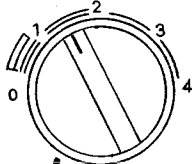

Stretch Stitch



A: Zigzag foot

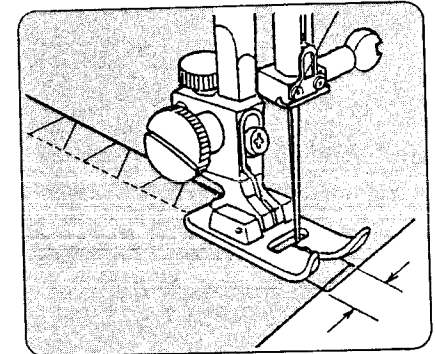

Use this stitch to join heavy weight interlining.
Overlap two raw edges together and use this stitch to join them.

SECTION 3. LEARN THE STITCHES

Zigzag Stitches (Continued)

• Fagoting Stitch

Set the Machine



Stitch width control 5

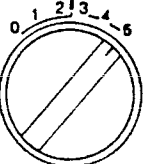

Top thread tension control 3 to 8

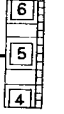

Stitch length control 0.5 to 2

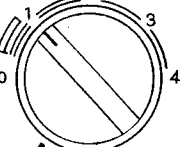

Stretch Stitch



A: Zigzag foot

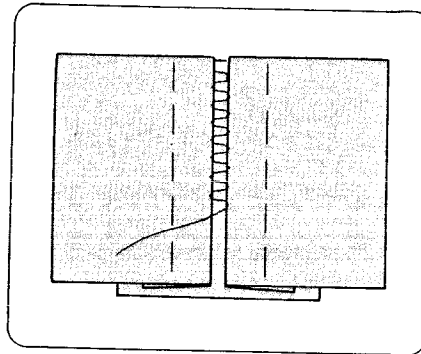

Here's How

1. Fold under each fabric edge 5/8" and press.
2. Pin the two edges to paper or tear-away backing 1/8" apart.
3. Sew slowly, guiding the fabric so the needle catches the folded edge on each side.

• Two-point Shell Stitch

Set the Machine

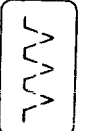

Stitch width control 3 to 5

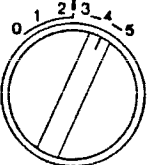

Top thread tension control 3 to 8

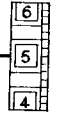

Stitch length control red zone

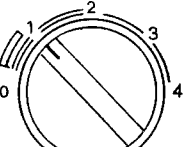

Stretch Stitch



A: Zigzag foot

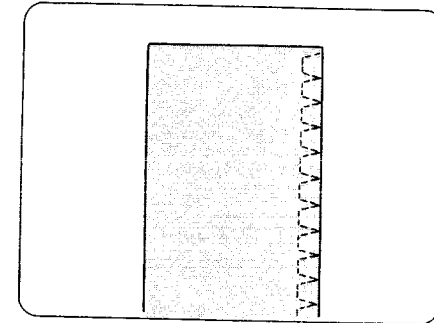

This stitch can also be used as a single overlock stitch.

The Stitch and Its Uses

Use this stitch to join two pieces of fabric to create an open work appearance and add design interest.

• Two-point Box Stitch

Set the Machine

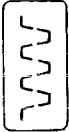

Stitch width control 3 to 5

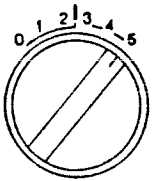

Top thread tension control 3 to 8

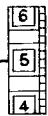

Stitch length control red

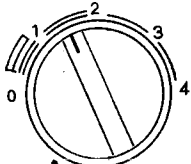

Stretch Stitch



A: Zigzag foot

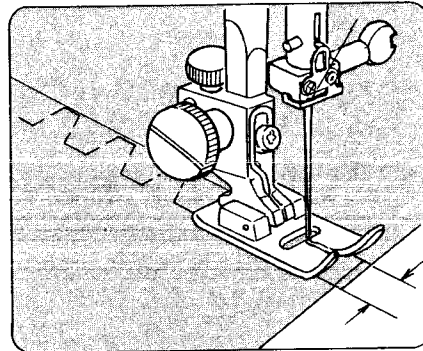

This stitch is useful to join elastic fabrics.

• Overedging Stitch

Set the Machine



Stitch width control 3 to 5

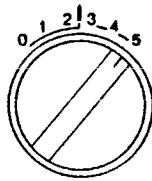

Top thread tension control 3 to 8



Stitch length control red

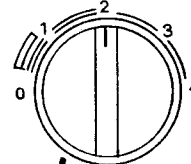

Stretch Stitch



A: Zigzag foot

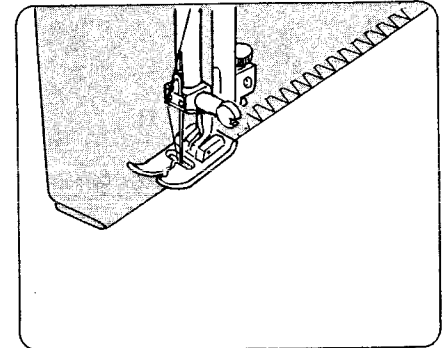

This stitch can be used as a seam finish to prevent fraying.

SECTION 3 LEARN THE STITCHES

Zigzag Stitches (Continued)

- Decorate with Geometric Patterns

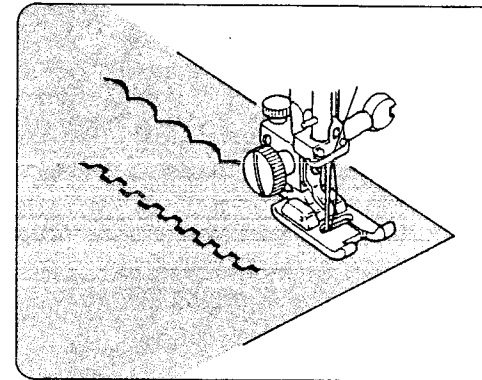
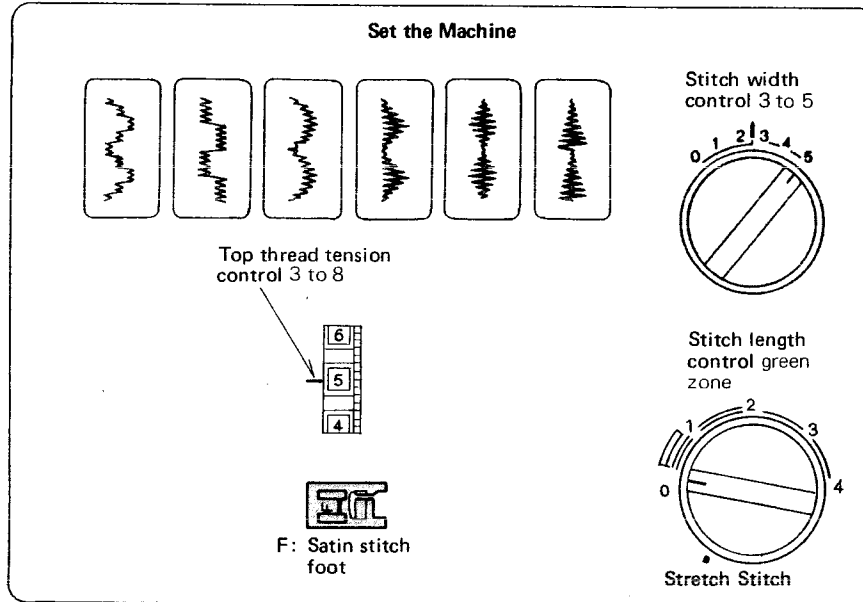

Here's How

1. Adjust the stitch width and length as you desire.
2. Practice the stitch on a scrap of fabric.
3. Mark the lines for decoration on the fabric, using a washable fabric marker.
4. Lower the needle at the starting point.
5. Lower the presser foot.
6. Gently guide the fabric along the marked line.

The Stitches and Their Uses

These stitches are purely decorative.

You can sew one row or several or vary the stitch width and length for special effects.

Experiment on a scrap of fabric to see what special effects are possible.

Stretch Stitches

• Straight Stretch

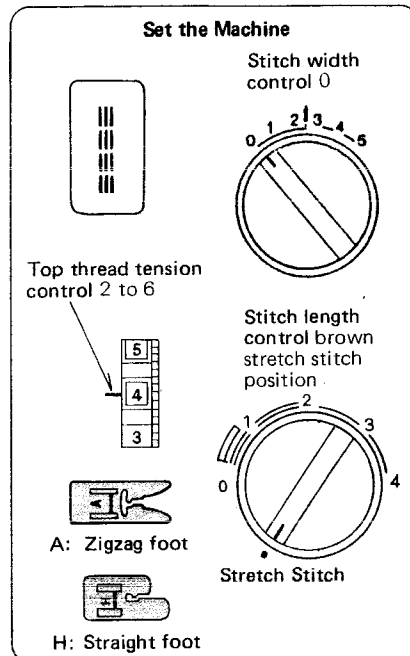

The Stitch and Its Uses

This stitch is the stretch variation of the straight stitch, especially developed for knits and stretch fabrics. Stretch stitching can be used on other fabrics as well. It works well on curved seams and on any garments that will receive a great deal of strain (ex: children's clothes).

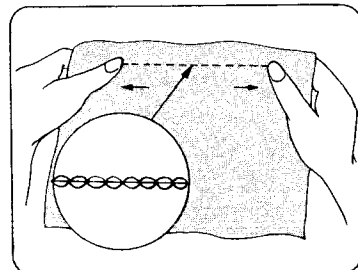
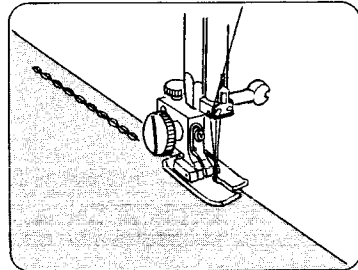

The stretch stitch does not actually stretch as it is being sewn, but is stitched in a forward and back motion (sometimes called a "reverse-action" stitch), so that it will give when the fabric stretches instead of breaking. This stitch can also be used for topstitching on all fabrics.

• Rick-Rack Stretch

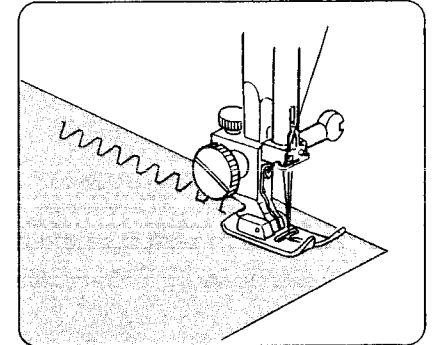
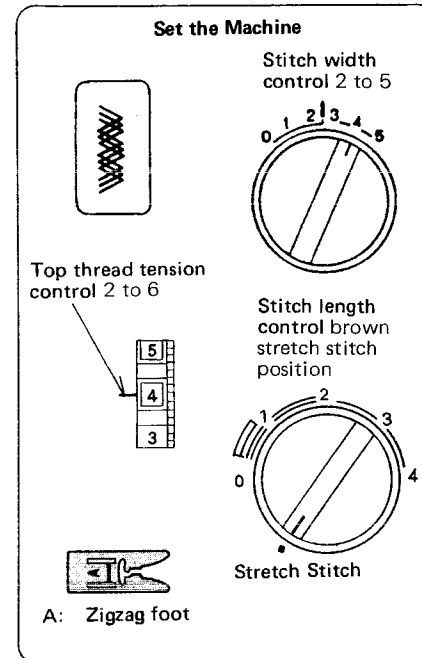

The Stitch and Its Uses

Sew on stretch fabrics in any area that you might use a zigzag stitch.

This stitch can be used as a decorative top stitch as well.

Stretch Stitches (Continued)

• **Overcast Stretch Stitching**

Set the Machine



Stitch width control 3 to 5

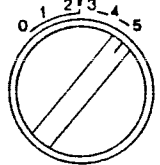

Top thread tension control 2 to 6

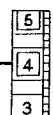

Stitch length control brown stretch stitch position

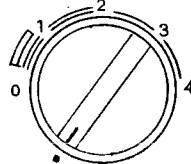

Stretch Stitch



A: Zigzag foot

The Stitch and Its Uses

This stitch can be used for sewing a seam with an overcast finish. The seam is formed and finished in one operation. It can be used when you are making swimwear, ski pants and other garments that require stretch.

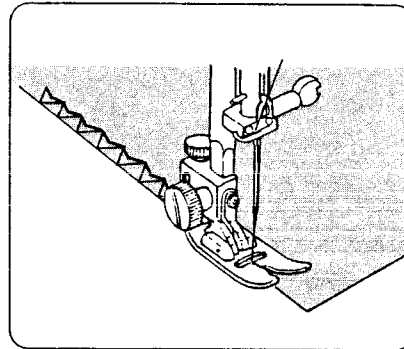

Here's How

Place the raw edge of the fabric to the **LEFT** of the needle as shown.

Stitch so the needle pierces the fabric just short of the outside edge.

Or, place your fabric to allow a 5/8" seam, then trim seam allowance after.

Raw or worn edges of older garments can be overcast to prevent further raveling.

NOTE: Use a blue stretch fabric needle, which effectively prevents skipped stitches.

• **Smocking**

Set the Machine

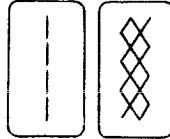

Stitch width control 3 to 5

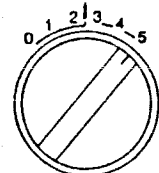

Top thread tension control 2 to 6

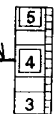

Stitch length control brown stretch stitch position

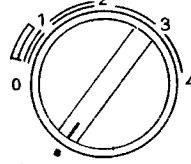

Stretch Stitch



A: Zigzag foot

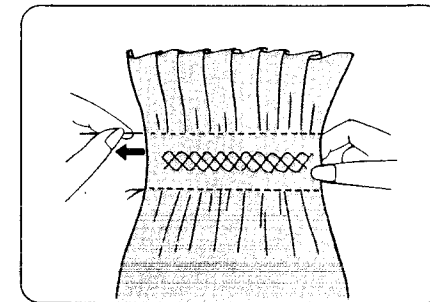
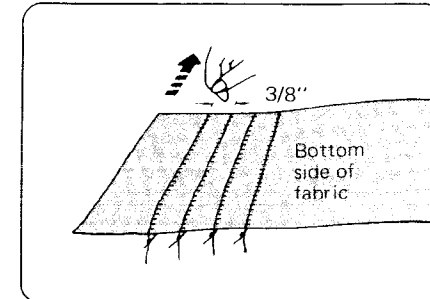

With the stitch length at "4", sew straight stitching lines 3/8" apart across the area to be smocked.

Knot the threads along one edge. Pull the bobbin threads and distribute the gathers evenly. Secure the threads at the other end. Sew the decorative stitch between the gathering stitches. Pull out the gathering stitches.

NOTE: Loosen the top thread tension to make gathering easier.

• Serging or Pine Leaf Stretch Stitching

Set the Machine



Stitch width control 3 to 5

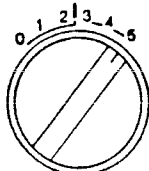

Top thread tension control 3 to 6

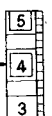

Stitch length control brown stretch stitch position

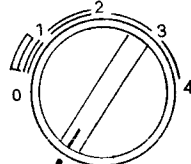

Stretch Stitch

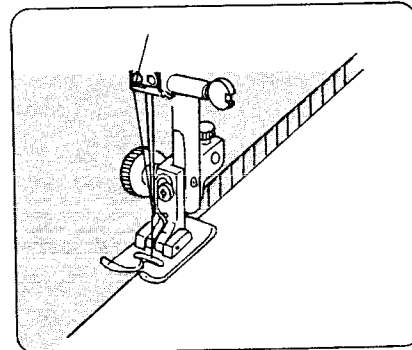
Here's How

Place the fabric under the presser foot so that the stitches are made over the edge.

NOTE: When using stretch knit fabric, use a blue stretch fabric needle which effectively prevents skipped stitches.

The Stitch and Its Uses

Use this stitch when you want a narrow seam that you do not need to press open flat. It is ideal for 1/4" seams on knits or on medium to heavyweight woven fabrics where you want a narrow seam. It is also great for sewing spandex swim wear.

• Elastic Stretch Stitch

Set the Machine

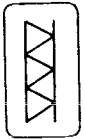

Stitch width control 3 to 5

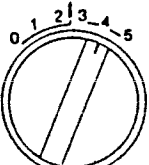

Top thread tension control 3 to 6

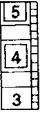

Stitch length control brown stretch stitch position

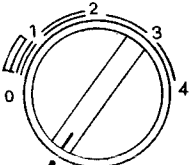

Stretch Stitch



A: Zigzag foot

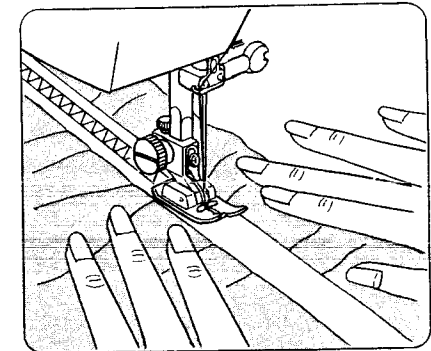
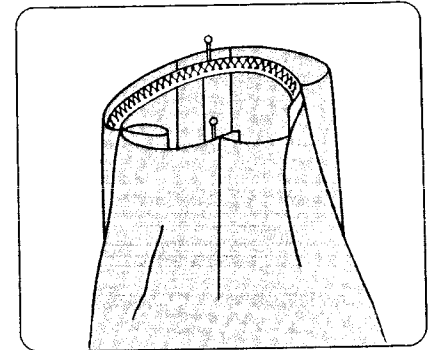

Choose this stitch to attach elastic to garments.

1. Mark the elastic into quarters and match these to the center front, center back and side seams.
2. Place the middle of the elastic under the center of the presser foot and stitch into place, making sure the elastic is evenly distributed.

Stretch Stitches (Continued)

• **Stretch Patching**

Set the Machine

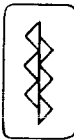

Stitch width control 5

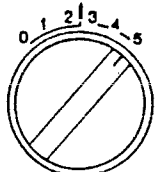

Top thread tension control 2 to 6



Stitch length control brown stretch stitch position

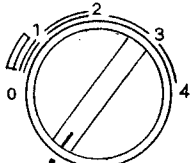

Stretch Stitch



A: Zigzag foot

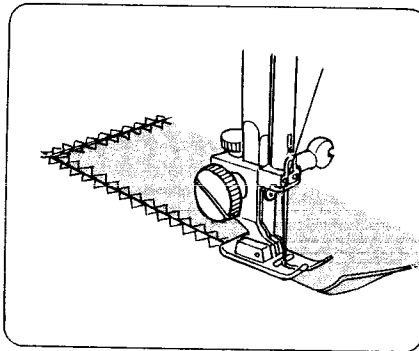

The Stitch and Its Uses

For patching worn out elbows or knees.

For patchwork quilting.

• **Herring Bone Stretch**

Set the Machine

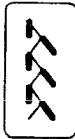

Stitch width control 3 to 5

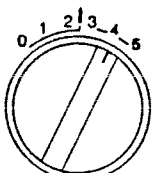

Top thread tension control 2 to 6



Stitch length control brown stretch stitch position

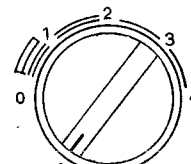

Stretch Stitch



A: Zigzag foot

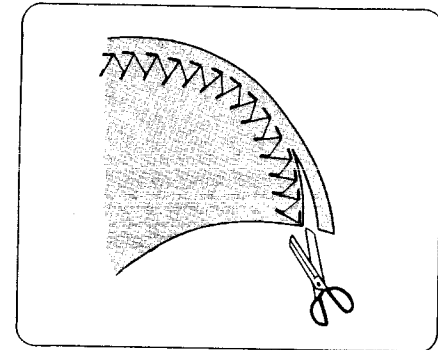

Here's How

Place the fabric top side up, and sew 3/8" from the edge.

Trim close to stitching. The stitch will prevent raveling.

The Stitch and Its Uses

Use as hemming stitch for blankets, tablecloths and draperies.

• Decorative Stretch Patterns

Set the Machine

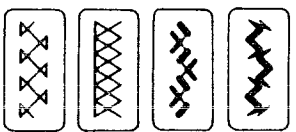

Stitch width control
3 to 5

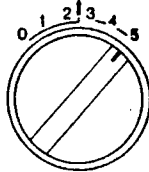

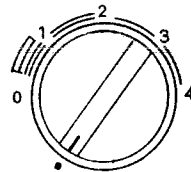

Stitch length control
brown stretch stitch
position

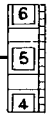

Stretch Stitch

Top thread tension
control 2 to 6

A: Zigzag foot

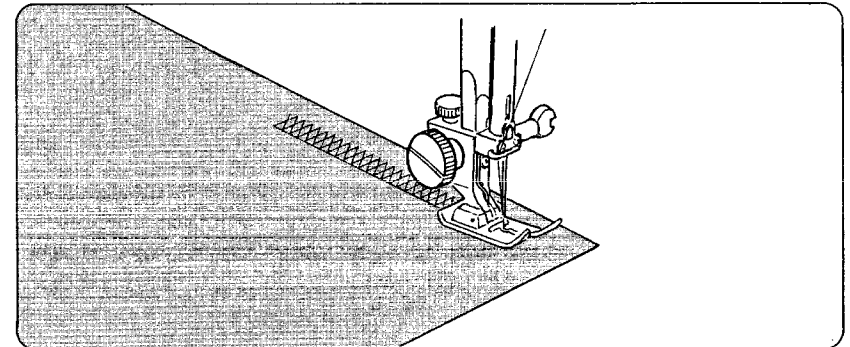

The Stitch and Its Uses

Decorative stretch patterns can be used for adding creative and personalised touch to the items you sew for your home and family.

You can decorate children's clothes, women's blouses, curtains, etc.

SECTION 3. LEARN THE STITCHES

Buttonhole Making

- Learning to Sew Buttonholes

With your Kenmore sewing machine you have two methods of making buttonholes. You may use the built-in system or you may use the optional snap-in automatic buttonholes attachment system.

Choose the buttonhole style

Built-in buttonholes (rectangular).

Choose this style for waistband, cuffs, belt slots or where you will need only one or two buttons.

Buttonhole Attachment (Optional Item)

Round end buttonholes (Template No. 213504005, 213505006).
Choose this style for series of buttonholes on dresses, blouses, vests, jackets or coats.

Keyhole buttonholes (Template No. 213506007).

Choose this style for tailored vests, jackets, coats or any time you need more room for button shank.

Note: See page 67 for ordering information of optional Buttonhole Attachment.

Tips on buttonholing

Always make a practice buttonhole on a scrap of fabric you plan to use. Try the buttonhole with the button you will use.

Always use an interfacing in area of garment where buttonholes are placed.

Tissue paper or regular interfacing can be used. Tear paper away after stitching, if it is used.

For heavier weight fabrics, loosen your top thread tension slightly.



• Built-in System

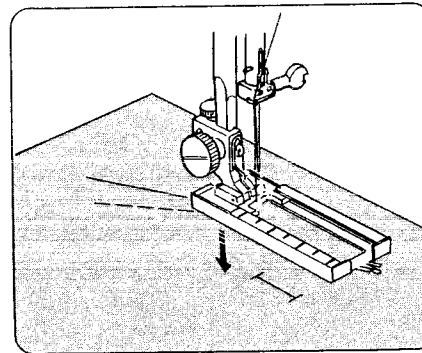
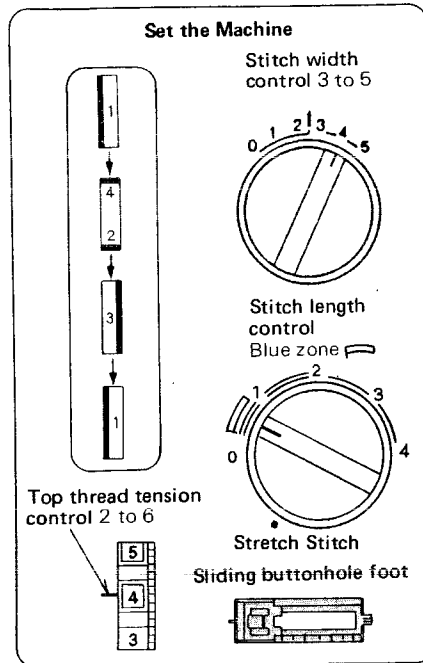

1. a. Carefully mark the buttonhole length on your garment.
- b. Change to the sliding buttonhole foot.
- c. Insert the garment under the foot with the buttonhole marking running toward you.

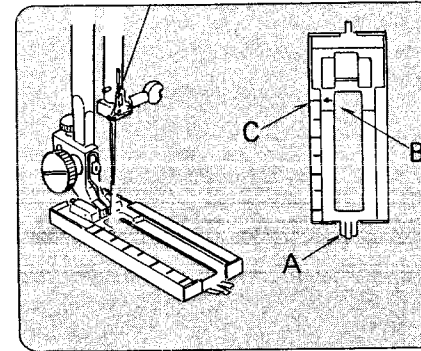

2. a. Move the slider (A) toward you so that the top mark (C) on the slider meets the start mark (B).
- b. Line up the markings on the foot with the top mark on your garment.
- c. Lower the presser foot.

NOTE: The markings on the slider are engraved in centimeters.

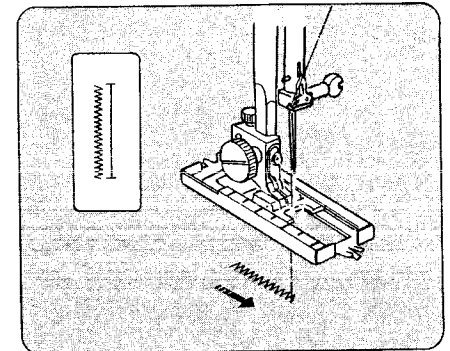

3. a. Set the stitch selector at [Symbol].
- b. Sew forward until you reach the front marking of your buttonhole.
- c. Stop sewing at the left stitch.

Adjusting the Stitch Density

Depending upon your fabric or your own preference in buttonholes, you may alter the buttonhole stitch density within the blue buttonhole range on the stitch length dial.

1. For less density, turn the dial toward "1".
2. For more density, turn the dial toward "0".

NOTE: Always make a practice buttonhole on a scrap fabric you plan to use to find the more suitable stretch length.

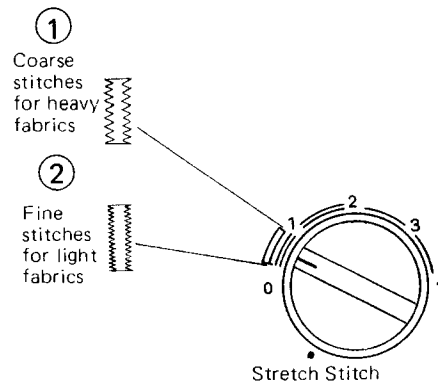

Buttonhole Making (Continued)

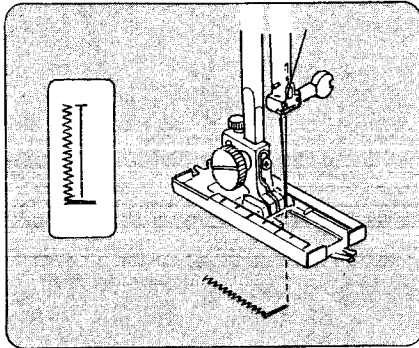

4. a. Set the stitch selector at .
- b. Sew 4 to 6 stitches.
- c. Stop sewing at the right stitch.

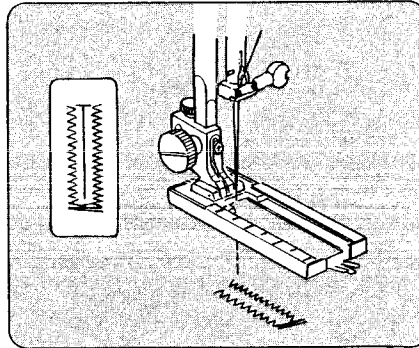

5. a. Set the stitch selector at .
- b. Sew until you reach the back of the buttonhole.
- c. Stop sewing at the right stitch.

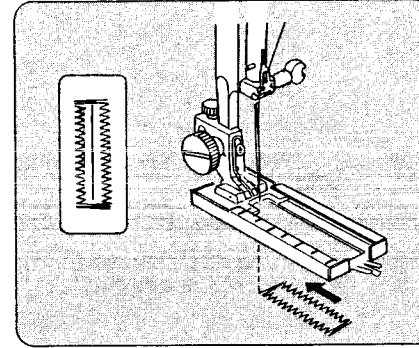



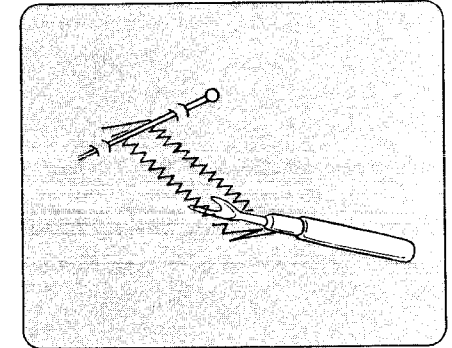

6. a. Set the stitch selector at .
- b. Sew 4 to 6 stitches.
- c. Stop sewing at the left stitch.
- d. Raise the presser foot, and draw the fabric away from you. Cut both the needle and bobbin threads leaving about 10 cm (4") thread ends. Draw the needle thread to wrong side of fabric by pulling the bobbin thread. Then, knot the threads.



7. Remove the fabric and cut the hole open with the buttonhole opener in your accessory storage box.

NOTE:

When sewing at the edge of fabric, set sliding buttonhole foot as illustrated and sew in reverse ( →  →  → ).

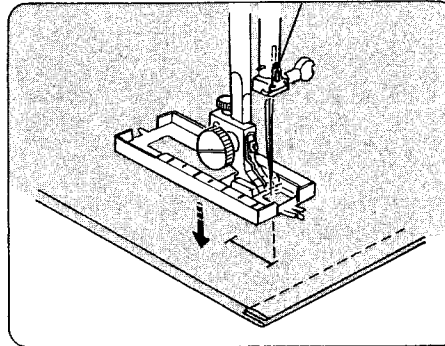

• Using Buttonhole Attachment

(NOTE: The buttonhole attachment is an optional item.)

Buttonhole Attachment System

For more varied and accurate buttonholes, you will enjoy using the buttonhole attachment and templates. Know the parts and carefully read how to set up your machine properly. You will need these items for the buttonhole attachment system.

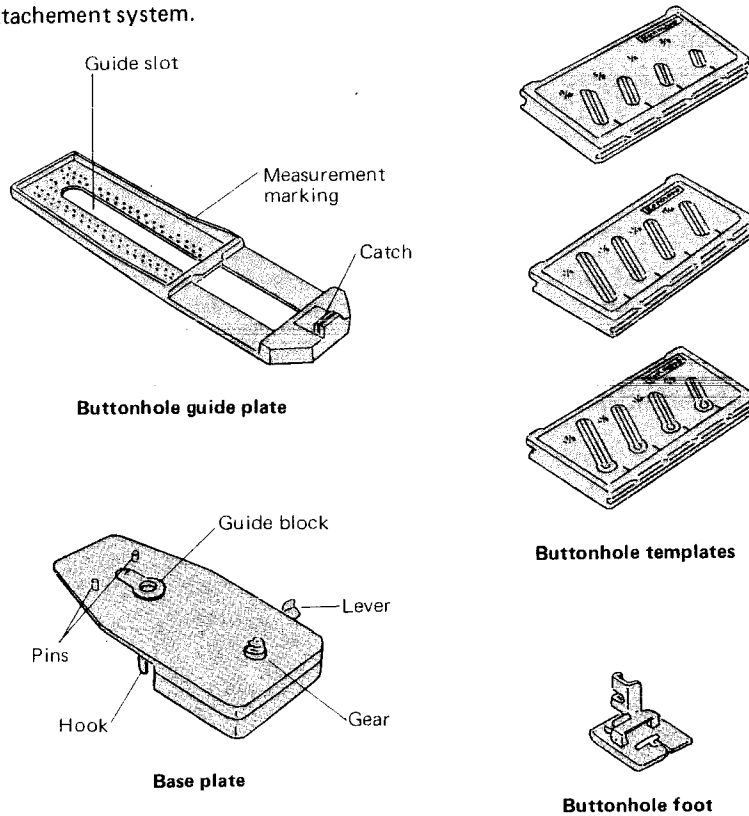

Buttonhole Style and Size

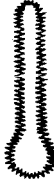
	Round End Buttonhole		Keyhole Buttonhole
			
Template	213504005	213505006	213506007
Sizes	3/8" 1/2"	15/16" 1-1/16"	7/8" 1-1/16"
	5/8" 13/16"	1-1/4" 1-1/2"	1-1/4" 1-3/8"

NOTE: Illustrations of buttonhole on template show actual length of buttonhole to be sewn. You will find the most suitable buttonhole length easily by matching the button with the proper illustration on the template.

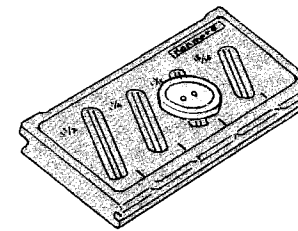

Buttonhole Making (Continued)

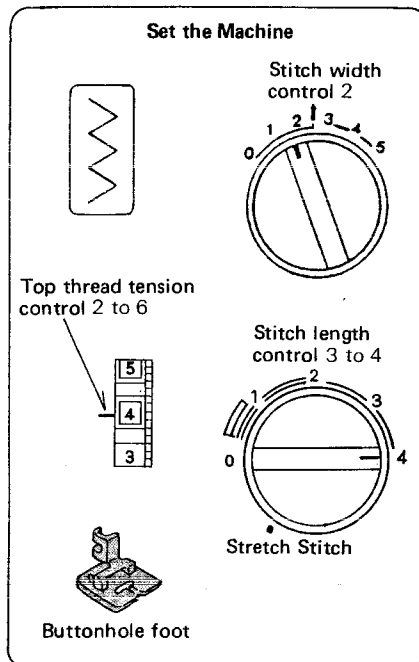
Helpful Hints

Best results are obtained by using #60 ~ #80 light weight threads as bobbin thread.

NOTE: It is advisable to use a blue stretch fabric needle when sewing knits and synthetic fabrics.

You can obtain buttonholes with a wider cutting space by setting the stitch width control at 1.5 instead of 2.

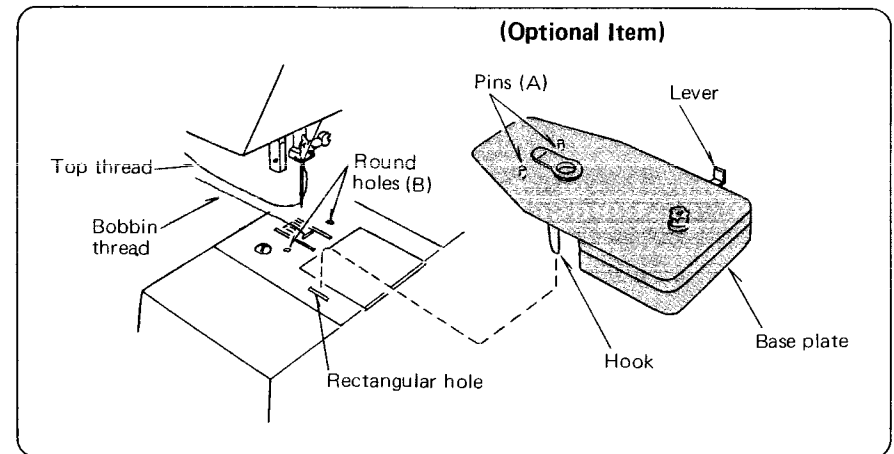

1. a. Remove the extension table.
 - b. Raise the needle to its highest position.
 - c. Remove the foot holder.
 - d. Pull bobbin thread out about 3" straight back toward rear of machine.
 - e. Insert hook of base plate into rectangular hole of needle plate.
 - f. Pull lever back to align the hook with the rectangular hole.
 - g. Snap base plate down to fit two pins (A) at the back of base plate into two round holes (B) on needle plate.
- Release lever.

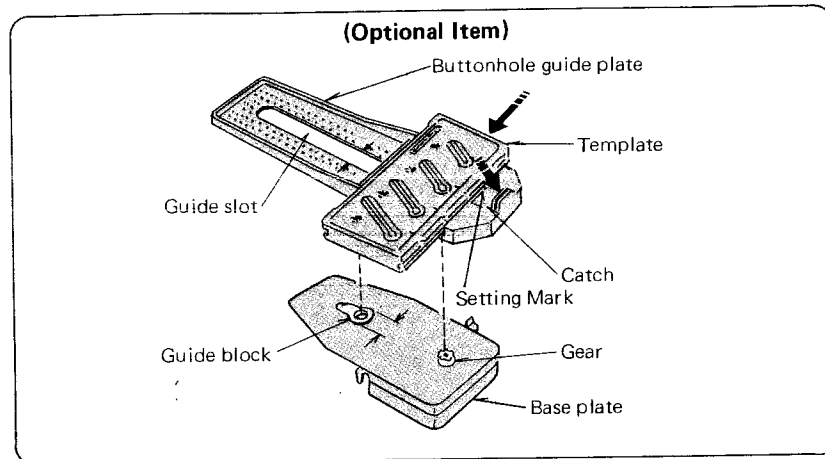

2.
 - a. When you have selected the template with the size and style buttonhole you need, slide the template into the guide plate.
 - b. Pull catch toward you while sliding the template until the buttonhole size you have chosen is at the setting mark.
 - c. Insert gear of base plate into slot of template and fit guide block into the center of the guide slot.

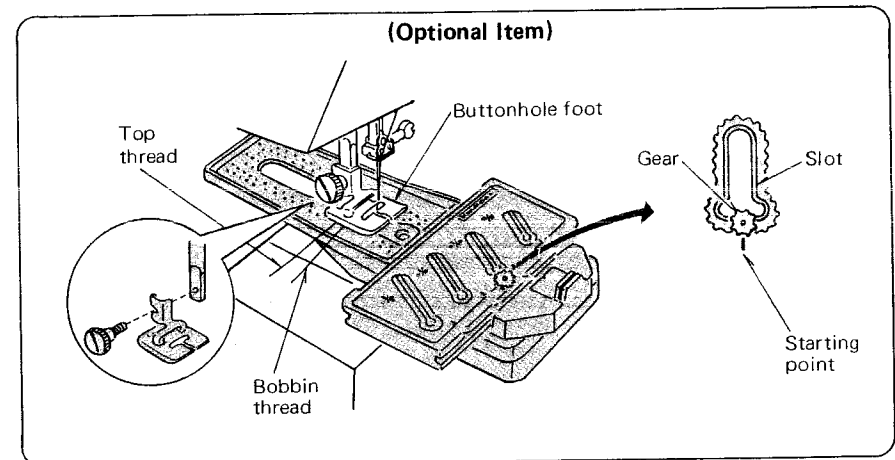

3.
 - a. Attach the buttonhole foot.
 - b. Adjust position of gear so it is aligned with the starting point of template.
The lever can be used to change gear position.
 - c. Pull the bobbin thread up through guide slot by turning the hand wheel toward you while holding top thread.
 - d. Place the bobbin and top threads to the left side of guide plate.
Leave 3 to 4 inches of thread.

SECTION 3 LEARN THE STITCHES

Buttonhole Making (Continued)

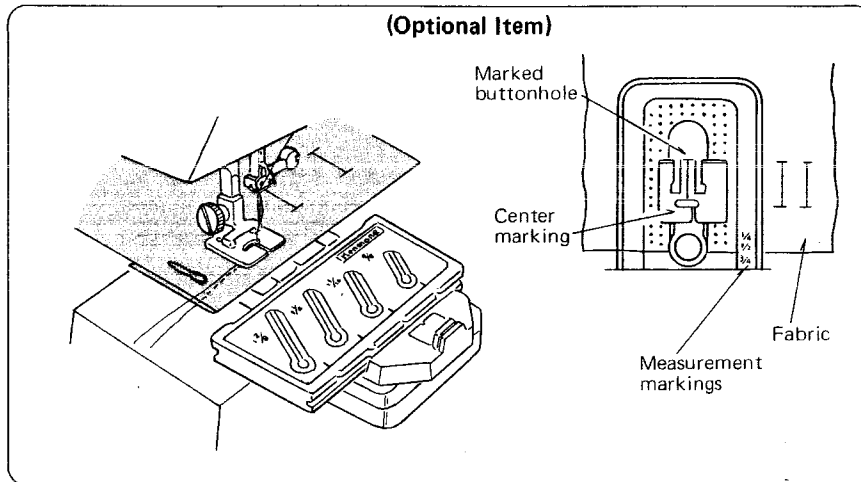

4. a. Mark your buttonhole position carefully on the garment.
- b. Placing your garment behind the machine, insert it between the guide plate and the buttonhole foot as shown.
- c. Align marked buttonhole with center marking on buttonhole foot.
- d. Line up your fabric edge with the measurement markings on the guide plate just in front of the buttonhole foot as shown.
- e. Pierce the fabric with the needle at the beginning of the buttonhole.

NOTE: If you want your buttonhole to be 1/2 inch from the garment edge, line up the fabric with the 1/2 inch markings each time you start to sew a buttonhole.

We recommended the use of interfacing when making buttonholes.

If the fabric does not feed smoothly from the start, increase the stitch length.

5. a. Lower the buttonhole foot.
- b. Start sewing slowly.
- c. Allow the machine to do the work by itself.
(Do not try to guide the fabric.)
- d. Stop sewing when the needle returns to the position where it begins.

To release the buttonhole base plate, pull the lever toward you and lift the base plate off the machine.

Adjusting the stitch density

You may alter the closeness of the stitches by turning the stitch length control between 3 and 4.

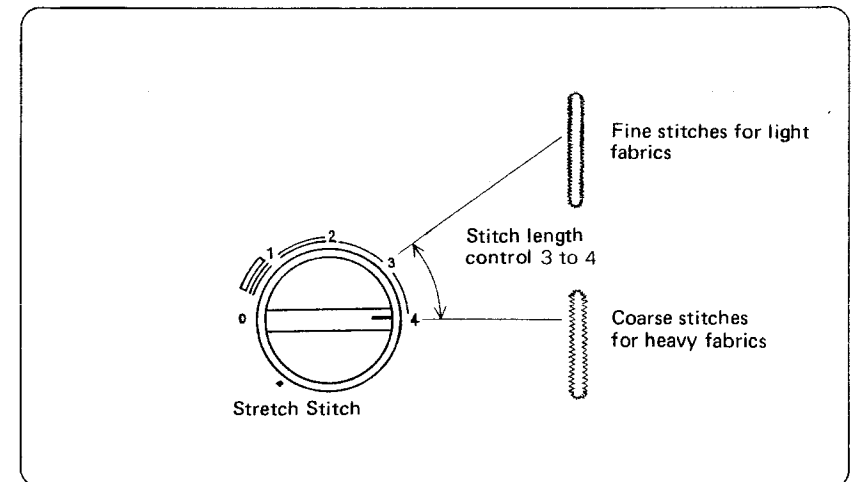

Twin Needle Stitching

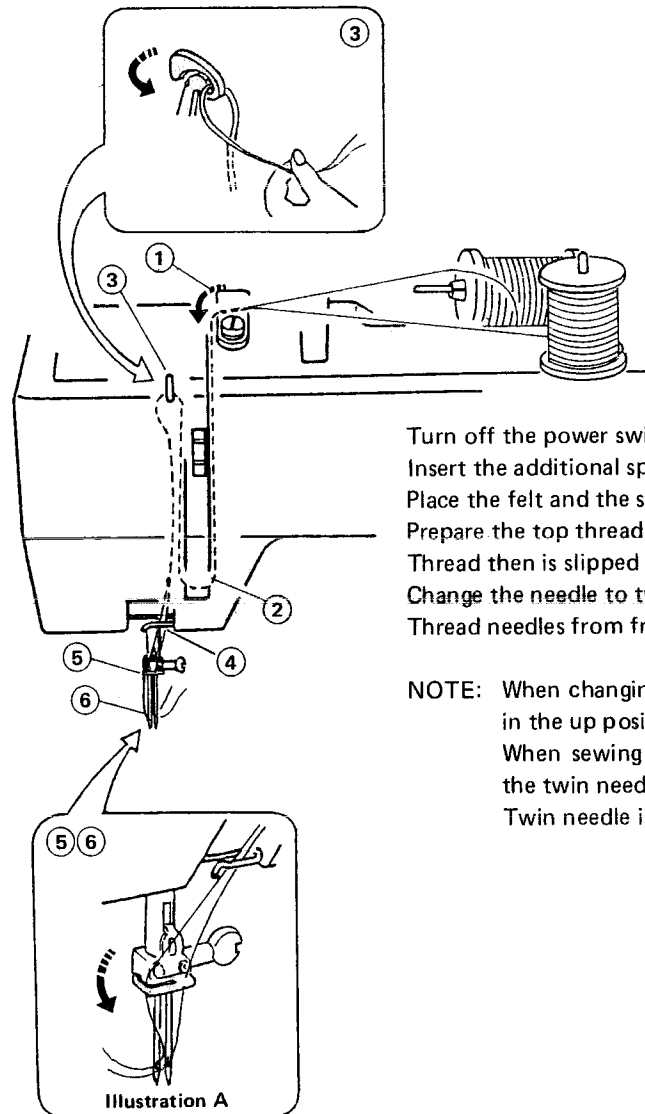
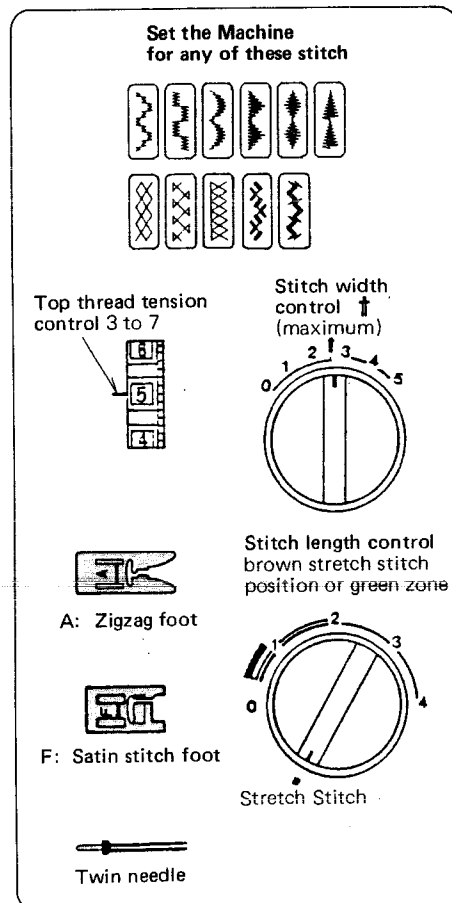

Turn off the power switch. (see page 6).

Insert the additional spool pin in the hole. (see page 16).

Place the felt and the spool on the additional spool pin. (see page 16).

Prepare the top thread for additional spool pin. (see page 19).

Thread then is slipped into needle bar thread guide as illustration A.

Change the needle to twin needle. (see page 15).

Thread needles from front to back.

NOTE: When changing the direction of sewing, turn the hand wheel so needles are in the up position.

When sewing with twin needle do not use a stitch width which goes past the twin needle mark ($\uparrow\uparrow$).

Twin needle is an optional item for all models.

SECTION 4 PERFORMANCE PROBLEMS CHART

What to Do When

PROBLEM	PROBABLE CAUSE	CORRECTION
Irregular Stitches	<p>Incorrect size needle. Improper threading. Loose upper thread tension. Pulling fabric. Loose presser foot. Unevenly wound bobbin. Nicks or burrs at hole of needle plate.</p>	<p>Choose correct size needle for thread and fabric. Rethread machine. Tighten upper thread tension. Do not pull fabric; guide it gently. Reset presser foot. Rewind bobbin. Replace needle plate, or polish off burrs completely.</p>
Breaking Needle	<p>Pulling fabric. Incorrect size needle. Incorrect setting of needle. Loose presser foot.</p>	<p>Do not pull fabric; guide it gently. Choose correct size needle for thread and fabric. Reset needle. Reset presser foot.</p>
Bunching of Thread	<p>Upper and lower threads not drawn back under presser foot before starting seam.</p>	<p>When starting a seam be sure to draw both threads under and back of presser foot about 4" and hold until a few stitches are formed.</p>
Puckering	<p>Incorrect thread tension. Using two different sizes or kinds of thread. Bent or blunt needle. Loose presser foot. Fabric too sheer or too soft.</p>	<p>Reset thread tension. Upper thread and bobbin thread should be same size and kind. Insert new needle. Reset presser foot. Use underlay of tissue paper.</p>

SECTION 4 PERFORMANCE PROBLEMS CHART

PROBLEM	PROBABLE CAUSE	CORRECTION
Skipping Stitches	Incorrect size needle. Bent or blunt needle. Incorrect setting of needle. Tight upper thread tension.	Choose correct size needle for thread and fabric. Insert new needle. Reset needle. Loosen upper thread tension.
Breaking Upper Thread	Starting to stitch too fast. Improper threading. Tight upper thread tension. Incorrect size needle. Sharp eye in needle. Nicks or burrs at hole of needle plate.	Start to stitch at a medium speed. Rethread machine. Loosen upper thread tension. Choose correct size needle for thread and fabric. Insert new needle. Replace needle plate, or polish off burrs completely.
Breaking Bobbin Thread	Improper bobbin threading. Lint in bobbin holder or hook race.	Check bobbin threading. Clean bobbin holder and hook race.
Fabric not Moving	Darning plate in place. Stitch Length set at 0. Thread knotted under fabric. Push-pull clutch is disengaged.	Remove darning plate. Adjust Stitch Length Control. Place both threads back under presser foot before beginning to stitch. Push in the clutch.
Machine Jamming Knocking Noise	Thread caught in hook race. Lint in bobbin holder or hook race.	Disassemble and clean hook race. Clean bobbin holder and hook race.

SECTION 5 CARE FOR THE MACHINE

Replace the Light Bulb

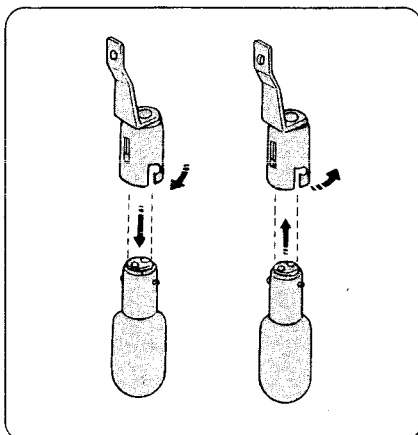

1. Unplug the machine and open the face cover plate.

CAUTION! The light bulb could be **HOT**. Protect your fingers when you handle it.

2. Push the bulb up and turn the bulb counter-clockwise to remove it.
3. Put the new bulb in by pushing it up and turning it clockwise.

Clean the Bobbin Holder

To insure that your machine operates at its best, you need to keep the essential parts clean at all times.

The bobbin area can collect dust and lint. Your machine can become sluggish or knock loudly if a thread is caught.

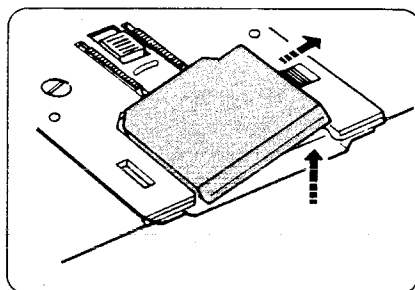

Turn off the power switch or unplug the machine.

Remove the cover plate by sliding the hook cover plate release button to the right.

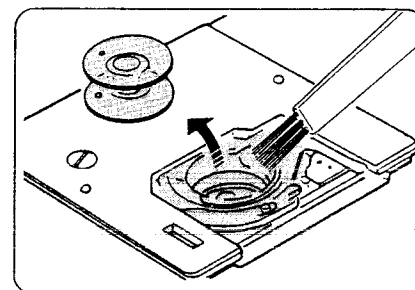

Take out the bobbin. Brush out dust and lint or you may use a vacuum cleaner.

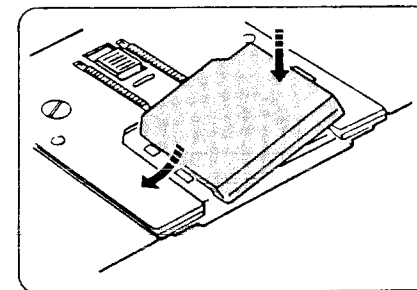

Insert the bobbin.

Attach the hook cover plate.

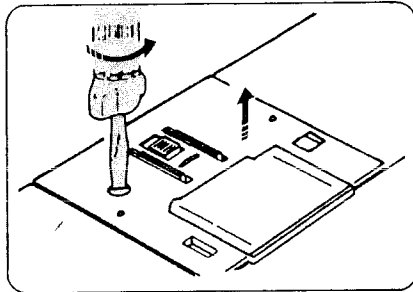
Clean the Hook Race and Feed Dogs

1. Unplug the machine and remove the presser foot and needle.
2. Remove the bobbin cover plate.
3. Remove the screw on the left side of the needle with the large screw driver.
4. Remove the needle plate.

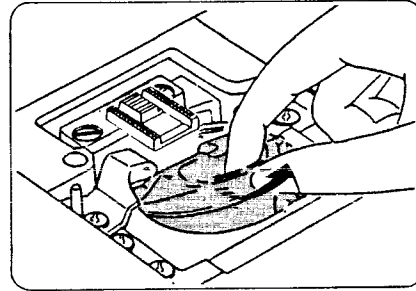

5. Take out the bobbin. Lift up the bobbin holder and remove it.

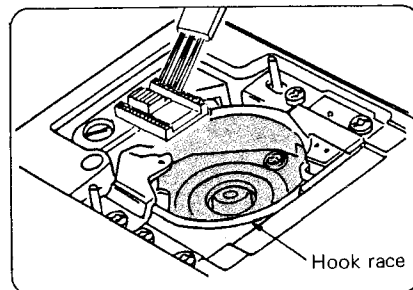

6. Use the lint brush to clean the feed dogs, hook race and bobbin holder. Also use a soft, dry cloth.

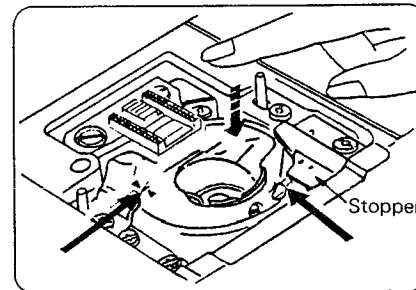

7. Line up the triangle marks and position the bobbin holder so the notch fits next to the stopper in the hook race.

Oiling the Machine

Open face cover plate and oil two points as shown below at least once a year. One or two drops of oil is sufficient. Remove excess oil, otherwise it may stain fabrics.

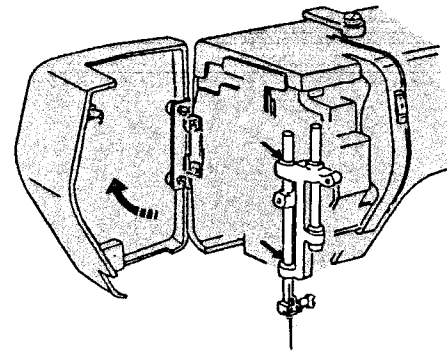

In case machine is not used for an extended time, oil it before sewing. Use good quality sewing machine oil.

No other oiling is required

Above points are only area which require oiling on this machine.

PARTS LIST

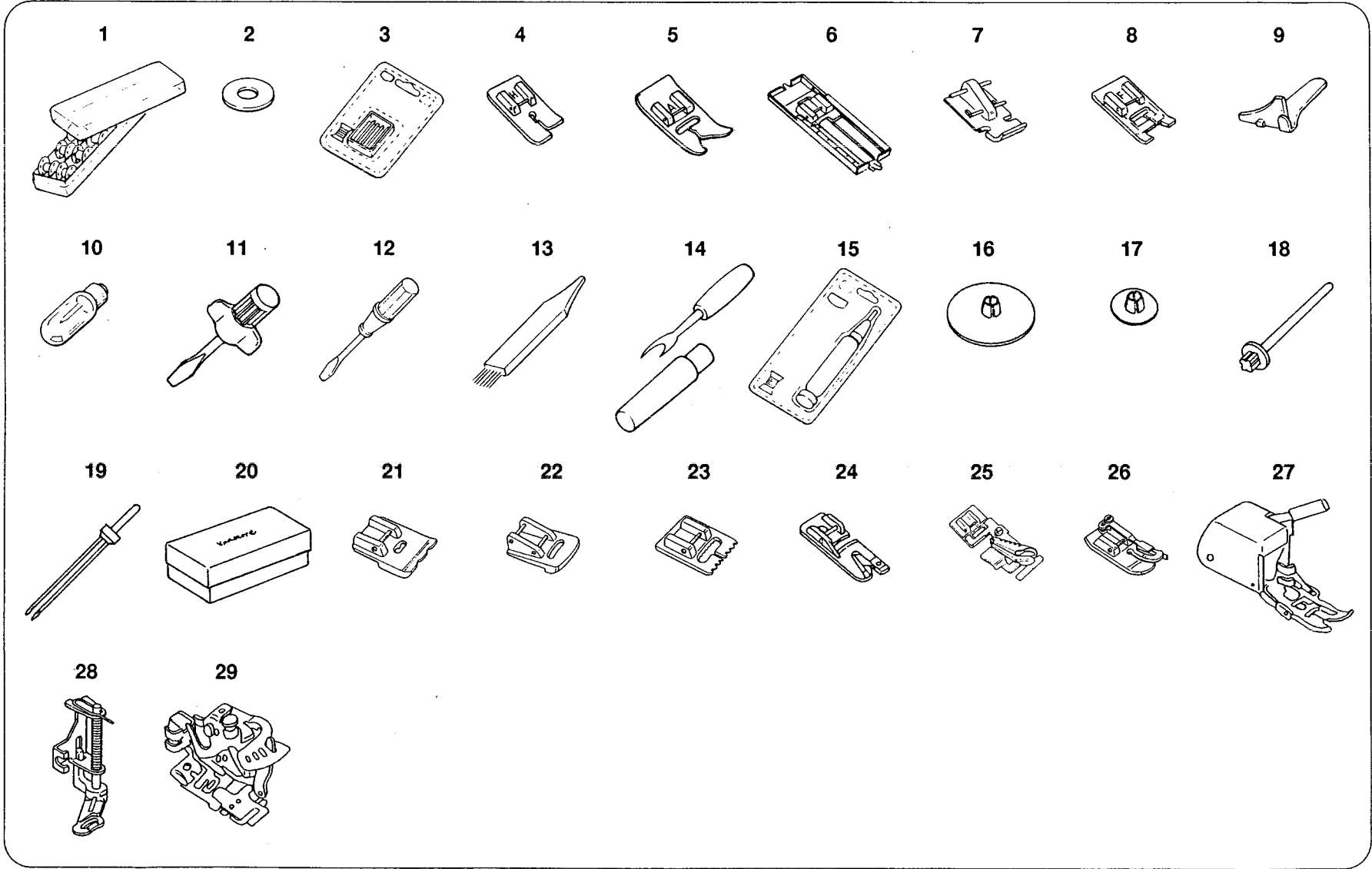

All parts listed herein may be ordered from any Sears Roebuck and Co. store or service center.

WHEN ORDERING REPAIR PARTS, ALWAYS GIVE THE FOLLOWING INFORMATION:

1. PART NUMBER
2. PART DESCRIPTION
3. MODEL NUMBER
4. NAME OF ITEM

if the parts you need are not stocked locally, your order will be electronically transmitted to a Sears Repair Parts Distribution Center for expedited handling.

Ref. No.	Ref. No.	Description
1	*102869107	Bobbin box with 10 bobbins
2	102403202	Spool pin felt
3	813404013	No. 11 Stretch fabric needles (BLU)
	647814020	No. 11 Single needles (ORG)
	647814031	No. 14 Single needles (RED)
	647814042	No. 16 Single needles (PUR)
	647814053	No. 18 Single needles (GRN)
4	652806015	Straight foot
5	685502019	Zigzag foot
6	825813005	Sliding buttonhole foot
7	823803006	Zipper foot
8	822804118	Satin stitch foot
9	*6864	Needle threader
10	000009803	Light bulb
11	820832005	Large screw driver
12	647803004	Small screw driver
13	802424004	Lint brush
14	647808009	Buttonhole opener
15	*6889	Oil and lint brush set
16	822020503	Large spool holder
17	822019509	Small spool holder
18	625031500	Additional spool pin
19	*826815000	Twin needle
20	*213702016	Buttonhole attachments
21	*200002008	Piping foot
22	*200003009	Gathering foot
23	*200005001	Pin-Tucking foot
24	*200013105	Hemmer foot
25	*200027102	Binder foot
26	*200030108	1/4" Seam foot
27	*214872000	Walking foot
28	*654805008	Embroidery foot
29	*941620000	Ruffler

* These items are not furnished with the machine, but may be ordered per instructions above.



INDEX

A

Accessory storage box 3, 9
 Additional spool pin 16
 Appliqueing 26, 38

B

Bar tacking 26, 38
 Base 3
 Base plate 67
 Basic zigzag 26, 36
 Blind hemming 26, 42
 Bobbin 5, 16~18, 64, 66~67
 Bobbin holder 18, 64~65
 Bobbin thread 20~21
 Bobbin winding 16~17
 Bobbin winding spindle 3, 16~17
 Box stitching 28, 45
 Buttonhole 30, 54~56
 Buttonhole attachment 54, 57~60, 66~67
 Buttonhole foot 57~60, 66~67
 Buttonhole guide plate 57~60, 67
 Buttonhole making 54~60
 Buttonhole opener 5, 56, 66~67
 Buttonhole template 57~60, 67
 Button sewing 26, 40

C

Cabinet 3
 Changing needle 15
 Changing presser foot 11~12
 Cleaning hook race and feed dogs 65
 Cornering guide 31, 39

D

Darning 26, 32
 Decorative geometric patterns 29, 48
 Drop feed lever 32

E

Elastic stretch 28, 51
 Embroidery 26, 39
 Extension table 3, 9

F

Fabric, needle, thread and stitch
 length chart 15
 Face cover plate 3, 7, 64~65
 Fagoting 28, 46
 Feed dogs 32, 65
 Foot control 4, 6
 Free arm sewing 9~10

H

Hand wheel 4, 20
 Herring bone stretch 29, 52
 Hook race 65
 Horizontal spool pin 16

L

Lace work 43
 Large screw driver 5, 66~67
 Light and power switch 4, 6
 Light bulb 64, 66~67
 Lint brush 5, 64~67

M

Monogramming 26, 36

N

Needle 14~15, 66~67
 Needle clamp 4, 15
 Needle plate 3, 18
 Needle, thread and fabric chart 15
 Needle threading 19~20

O

Oiling 65
 Overcasting stitch 41
 Overcast stretch 27, 50
 Overedging stitch 29, 47

P

Parts list 66~67
 Performance problems 62~63

Plug connector 4, 6
 Portable case 3
 Power switch 4, 6
 Practical stitch chart 26~30
 Pressure control dial 7
 Presser foot 4, 11~13
 Presser foot lever 4, 8
 Push-pull clutch 4, 17

R

Reverse stitch control 3, 25, 31
 Rick-rack stretch stitching 26, 49

S

Satin stitch foot
 5, 13, 27, 30, 37~39, 45, 66~67
 Satin stitching 29, 37
 Seam guides 31
 Serging 27, 51
 Serging or pine leaf stretch 27, 51
 Sewing light 6
 Shell stitching 27, 45
 Sliding buttonhole foot
 5, 13, 30, 55~56, 66~67
 Small screw driver 5, 66~67
 Smocking 27, 50
 Snap-on button 4, 11
 Spool pin felt 5, 66~67
 Spool pin 3
 Stitch length control 3, 24
 Stitch selector 4, 23
 Stitch width control 3, 24
 Straight stitching 26, 31~35
 Straight stitch foot
 5, 12, 26, 31, 33, 49, 66~67
 Straight stretch stitching 26, 49
 Stretch patching 28, 52
 Stretch stitch adjuster 4, 24

T

Take-up lever 3, 19
 Thread cutter 3, 19

Thread guide	3~4, 19
Three-step zigzag	27, 44
Topstitching	26, 33
Twin needle stitches	61
Top thread	19~22
Top thread tension	21~22
Top thread tension control	3, 21~22
Turning a square corner	31
Two-point box stitching	29, 47
Two-point shell stitching	28, 46

Z

Zigzag foot	12, 26~30, 38, 40~47, 49~53, 66~67
Zigzag stitching	26, 36~48
Zigzag overcasting	41
Zipper application	26, 34~35
Zipper foot	5, 13, 26, 34~35, 66~67

WARRANTY

FULL 25-YEAR WARRANTY ON SEWING MACHINE HEAD

For 25 years from the date of purchase, Sears will, free of charge, repair defects in material or workmanship which appear in the mechanical components of the sewing machine head.

FULL TWO YEAR WARRANTY ON ELECTRICAL EQUIPMENT OF SEWING MACHINE

For two years from the date of purchase, Sears will, free of charge, repair defects in material or workmanship which appear in the electrical equipment of the sewing machine, including electronic components, motor, wiring, switch and speed control.

FULL 90-DAY WARRANTY ON ALL PARTS AND MECHANICAL ADJUSTMENTS

For 90 days from the date of purchase, Sears will, free of charge, replace any parts and provide mechanical service necessary for proper operation of the sewing machine, except for normal maintenance.

WARRANTY SERVICE IS AVAILABLE BY RETURNING THE SEWING MACHINE TO THE NEAREST SEARS SERVICE CENTER/DEPARTMENT IN THE UNITED STATES.

This warranty gives you specific legal rights, and you may also have other rights which vary from state to state.

SEARS, ROEBUCK AND CO., D/817 WA, Hoffman Estates, IL 60179

SEWING MACHINE

Now that you have purchased your Kenmore Sewing Machine, should a need ever exist for repair parts or service, simply contact your nearest Sears Service Center. Be sure to provide all pertinent facts when you call or visit.

The model number of your Sewing Machine will be shown on your nomenclature plate on the back of your Sewing Machine. See page 4 for location.

WHEN ORDERING REPAIR PARTS, ALWAYS GIVE THE FOLLOWING INFORMATION:

*PART NUMBER *PART DESCRIPTION *MODEL NUMBER *NAME OF ITEM

If the parts you need are not stocked locally, your order will be electronically transmitted to a Sears Repair Parts Distribution Center for handling.

SEARS, ROEBUCK AND CO., Chicago, IL60684 U.S.A.