

Sunbeam

Prima Latte Espresso Machine

User Guide

EMP5100BK



SCAN HERE
For more
information

Contents

Sunbeam's safety precautions	1
Getting to know your espresso machine	2-3
Using the adjustable cup platform	4
Before using your appliance for the first time	5
Selecting the right coffee	6
Let's make a coffee	7
Using the group handle	8
Select the function	10
Cleaning your machine	13
Troubleshooting guide	17

Important instructions - retain for future use

تأكد من تفهم احتياطات السلامة المذكورة اعلاه

請務必理解上述的安全預防措施。

Assurez-vous que les précautions ci-dessus relatives à la sécurité sont bien comprises

Versichern Sie sich, dass die obenstehenden Sicherheitsmaßnahmen Verstanden werden

Βεβαιώστε πως οι παραπάνω προφυλάξεις ασφαλείας γίνονται κατανοητές

Pastikan bahwa tindakan-tindakan keselamatan seperti di atas dimengerti anda

Accertatevi che le suddette norme di sicurezza siano comprese a dovere

上記の注意事項をよくお読みになり、安全を御確認ください

Уверете се дека погоре споменатите мерки на претпазливост се добро разбрани

Asegúrese de que las precauciones de seguridad precedentes sean bien comprendidas

کاری یکنید کہ احتیاط‌های بالا حتماً درک بشوند

ต้องแน่ใจว่า ข้อควรระวังเรื่องความปลอดภัยข้างต้น เป็นที่เข้าใจกันดี

Yukarda belirtilen güvenlik önlemlerinin anlaşıldığından emin olunuz

Xin kiểm chắc rằng những biện pháp làm an toàn kể trên được hiểu rõ

Sunbeam's safety precautions

SAFETY PRECAUTIONS FOR YOUR SUNBEAM ESPRESSO MACHINE.

- Always place the unit on a flat, level surface.
- Do not operate without water in reservoir.
- Do not remove the filter holder during water flow or coffee flow as the unit is under pressure. Removing the filter holder during operation can lead to a scalding or injury.
- Clean the steam nozzle only when the unit has been switched off and allowed to cool.
- Disconnect the plug from the power outlet if there is any problem during the coffee making process or prior to cleaning your appliance.
- Do not allow the power cord to come into contact with the hot parts of the appliance (cup warming plate, filter holder, steam nozzle).
- Keep hands away from hot parts of the appliance, including the cup warming plate, filter holder and steam nozzle.
- Misuse may potentially cause injury or physical damage to the user.
- The heating element surface is subject to residual heating after use.
- Cleaning and user maintenance shall not be made by children without supervision.
- Do not place in a cabinet when in use.

Sunbeam is very safety conscious when designing and manufacturing consumer products, but it is essential that the product user also exercise care when using an electrical appliance. Listed below are precautions which are essential for the safe use of an electrical appliance:

- Read carefully and save all the instructions provided with an appliance.
- Always turn the power off at the power outlet before you insert or remove a plug. Remove by grasping the plug - do not pull on the cord.
- Turn the power off and remove the plug when the appliance is not in use and before cleaning.
- Do not use your appliance with an extension cord unless this cord has been checked and tested by a qualified technician or service person.
- Always use your appliance from a power outlet of the voltage (A.C. only) marked on the appliance.
- This appliance is not intended for use by persons (including children) with reduced physical, sensory or mental capabilities, or lack of experience and knowledge, unless they have been given supervision or instruction concerning use of the appliance by a person responsible for their safety.
- Children should be supervised to ensure that they do not play with the appliance.
- The temperature of accessible surfaces may be high when the appliance is operating.
- Never leave an appliance unattended while in use.
- Do not use an appliance for any purpose other than its intended use.
- Do not place an appliance on or near a hot gas flame, electric element or on a heated oven.
- Do not place on top of any other appliance.
- Do not let the power cord of an appliance hang over the edge of a table or bench top or touch any hot surface.
- Do not operate any electrical appliance with a damaged cord or after the appliance has been damaged in any manner. If damage is suspected, return the appliance to the nearest Sunbeam Appointed Service Centre for examination, repair or adjustment.
- For additional protection, Sunbeam recommends the use of a residual current device (RCD) with a tripping current not exceeding 30mA in the electrical circuit supplying power to your appliances.
- Do not immerse the appliance in water or any other liquid unless recommended.
- This appliance is not intended to be operated by means of an external timer or separate remote control system.
- This appliance is intended to be used in household and similar applications such as: staff kitchen areas in shops, offices and other working environments; farm houses; by clients in hotels, motels and other residential type environments; bed and breakfast type environments.

If you have any concerns regarding the performance and use of your appliance, please visit www.sunbeam.com.au or contact the Sunbeam Consumer Service Line.

Ensure the above safety precautions are understood.

Getting to know your espresso machine

Start/Stop Button

The LED stays fully illuminated when ready. When pressed, the LED pulses on and off to signal that brewing is in progress.

Shot Selection Button

1 Shot: When selected, pours a single shot of espresso or a small capp/latte.

2 Shot: When selected, pours a double shot of espresso or a large capp/latte.

NOTE: The last selected (single shot or double shot) will always be illuminated until changed.

On/Off Power Button

The LED illuminates and pulses on and off to indicate that the unit is heating up. When ready, it remains fully illuminated and ready for use.

Brew Head

See “Placing the Group Handle” section for detailed information.

Group Handle

See “Placing the Filter on the Group Handle” and “Placing the Group Handle” sections for detailed information.

Height Adjusting Slot

For small cups.

Drip Tray Water Level Float





See “Cleaning the Drip Tray” section.

Adjustable Cup Platform

For small cups.

The adjustable cup platform can be removed and inserted into the height-adjusting slot. Refer to “Using the Adjustable Cup Platform”.

Mode Selection Knob

-  Latte
-  Cappuccino
-  Espresso
-  Manual Espresso
-  Manual Milk Frothing

Clean Button

See “Deep Cleaning Notification” section for detailed information.

Milk Tank Knob

Allows you to switch between:

- **Milk Froth:** See “Filling the Milk Tank” in the “Let’s Make a Coffee” section.
- **Clean:** See “Cleaning the Milk Tank and Frothing System” section.
- **Unlock:** See “Cleaning the Milk Tank and Frothing System” section.

Removable Milk Tank

See “Filling the Milk Tank” in the “Let’s Make a Coffee” section for detailed information.

Frothed Milk Dispensing Tube

Dispense froth milk to your beverage.

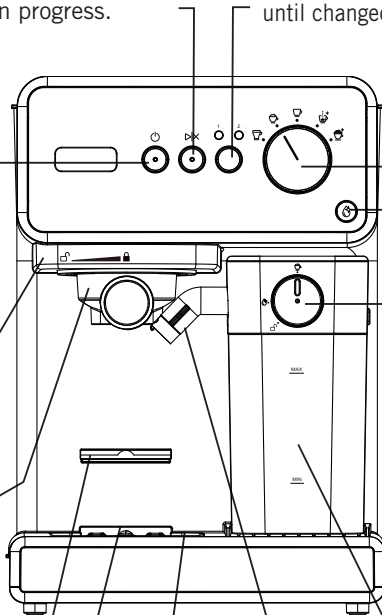

Getting to know your espresso machine

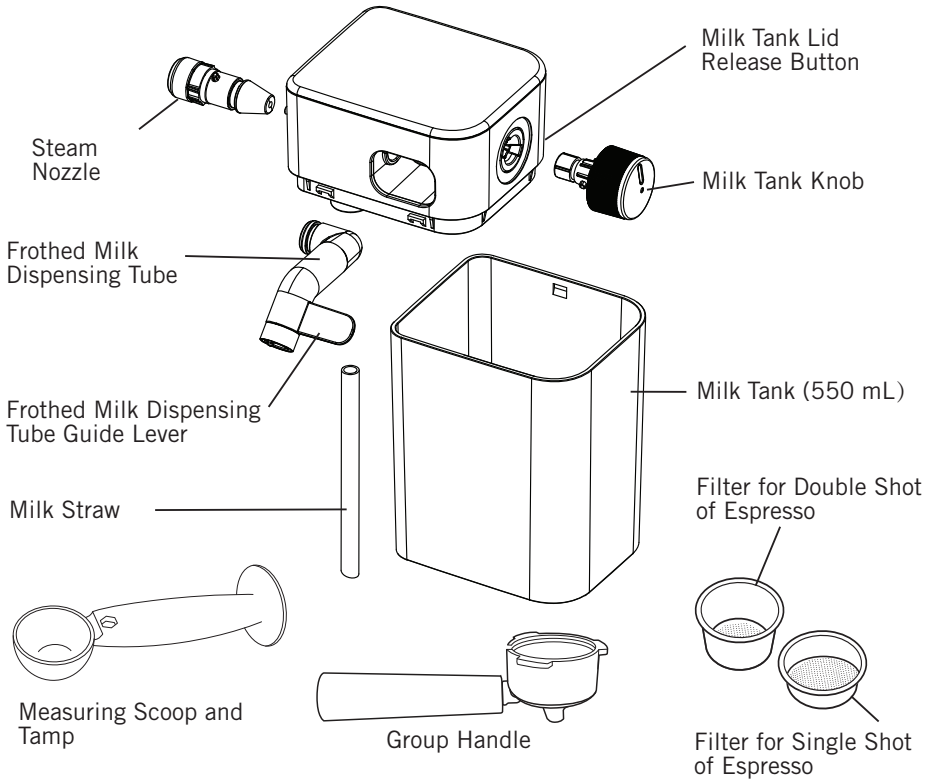

Using the adjustable cup platform

You can remove the adjustable cup platform to clean the drip tray or use it in the height-adjusting slot when using a small cup.

To remove the adjustable cup platform, tilt it at a 45° angle while pulling it out.

To insert the adjustable cup platform into the height-adjusting slot, tilt it at a 45° angle while inserting it into the slot.

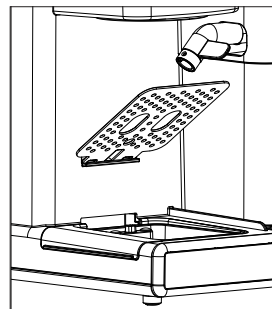
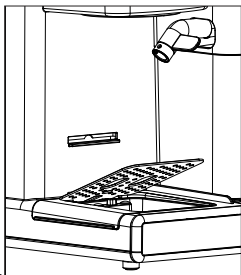

Introduction to café classics made simple

Congratulations! You have selected the new and innovative Sunbeam® Prima Latte Espresso Machine. This unique appliance has been designed to help you prepare delicious espressos, cappuccinos, and lattes quickly, conveniently, and automatically with the touch of a button: Café Classics made simple!

Please read ALL the instructions and notes in this manual carefully before using this appliance. When this unit is used, some parts and accessories get hot and need to cool down. Proper care and maintenance will ensure your Prima Latte Espresso Machine's long life and trouble-free operation. Save these instructions and refer to them often for cleaning and care tips.

This espresso machine uses ground coffee. You can buy your coffee ground for espresso or grind beans freshly in a separate coffee grinder.

ESPRESSO

Espresso is a unique method of coffee brewing in which hot water is forced through finely ground coffee. Popular across Australia and New Zealand, it is a far richer and more full-bodied brew than traditional filter coffee. Because of its richness, espresso is usually served in 30 to 60 mL portions in espresso cups.



CAPPUCCINO

A drink made with about 1/3 espresso and 2/3 steamed/frothed milk.



LATTE

A drink made with about 1/4 espresso and 3/4 steamed/frothed milk.



Before using your appliance for the first time

CLEAN YOUR ESPRESSO MACHINE PRIOR TO FIRST USE

Please refer to the “Getting to Know Your Espresso Machine” section to familiarise yourself with the product and identify all its parts.

1. Ensure the Prima Latte Espresso Machine is not plugged into any electrical outlet.
2. Remove stickers and labels from the unit.
3. Remove red plug from the bottom of the water reservoir.
4. Firstly, wash all 13 parts below in warm water with a mild detergent:

- Drip Tray Mesh

Milk Frothing System parts:





- Milk Tank Lid
- Steam Nozzle
- Frothed Milk Dispensing Tube
- Milk Straw
- Milk Tank

Important: Below 7 parts are NOT DISHWASHER SAFE:

- Group Handle
- Single and Double Filter Baskets
- Milk Tank Knob
- Measuring Scoop/Tamp
- Drip Tray
- Water Tank

5. Before placing or removing the Group Handle and any filter from the unit, refer to the instructions in the “Placing the Group Handle” section.
6. To clean the inside of the appliance, follow the steps listed in the “Deep Cleaning Procedure” section using water in both the water reservoir and milk tank and no ground coffee in the filter. **CAUTION:** Do not immerse the main body of the appliance or power cord and plug in water or attempt to reach any of its internal parts.

IMPORTANT - PRIME YOUR MACHINE PRIOR TO FIRST USE

1. Fill the water reservoir up to the “MAX” line and ensure that the reservoir is securely placed back in the unit with its lid closed.
2. Fill the milk tank with water up to the MAX level, then slide it back into place. You should feel the milk tank click into position.
3. Select either a single or double espresso filter and place it in the Group Handle. Insert the Group Handle into the brew head, ensuring it is securely locked by gradually turning the handle to the right until it is aligned with the unit’s full lock symbol “”, and the Group Handle handle facing directly towards you. Then, position a large empty cup (with at least 325 mL capacity) underneath.
4. Plug the appliance into an appropriate outlet.
5. Press the Power button “” located on the front of the unit. The LED on the button illuminates and pulses to indicate warming up. When ready, the button remains fully illuminated and enters Standby mode.
6. Press the Shot Selection button to choose the double shot (2) option. The indicator LED (2) will illuminate.
7. Use the Mode Selection knob to select the Latte option “”.
8. Press the Start/Stop button “” to allow the unit to brew with water until it stops automatically. The LED on the button will illuminate and pulse on and off to signal that brewing is in progress.
9. Empty the water from the cup and return it to the unit. Additionally, ensure that the tip of the frothed milk dispensing tube is directed into the cup.

10. Turn the Milk Tank knob anti-clockwise until it clicks into the clean position “☺”.

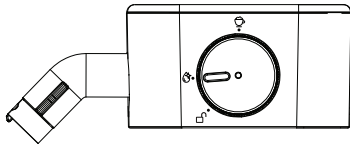

11. Press the Clean button to activate the cleaning function. The Clean button LED pulses on and off to signal the cleaning cycle is in progress. Allow the cleaning cycle to run until it stops automatically, which will take approximately 30 seconds.
12. Repeat steps 8-11 to ensure the unit is fully primed.
13. Empty any remaining water in the milk tank and then slide it back into place. You should feel the milk tank click into position.
14. Adjust the Milk Tank knob back to the vertical Milk Froth position “☹”.

IMPORTANT: This is critical to ensure correct operation for the next espresso/ milk cycle.

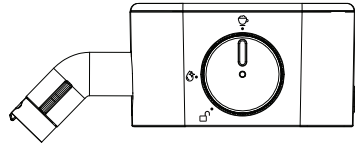

15. Empty the water from the cup.
16. Now, your unit has been primed and is ready to be used.

HOW TO SELECT THE RIGHT CUP

Please make sure to select your cup according to the following chart:

BEVERAGE		SUGGESTED CUP
Espresso ☺	Single (1) Double (2)	70 mL 100 mL
Cappuccino ☹	Small (1) Large (2)	250 mL 300 mL
Latte ☺	Small (1) Large (2)	350 mL 450 mL

The total volume of the beverage can vary based on the type of milk and the amount of froth used.

Selecting the right coffee

THE COFFEE

For the best flavour, use quality coffee, freshly ground specifically for espresso coffee. Keep in mind that pre-ground coffee only retains its flavour for about 7 to 8 days, provided it is stored in an airtight container in a cool, dark place. Avoid storing coffee in the refrigerator or freezer.

THE GRIND

If you have a separate grinder, it is recommended that whole beans are ground just before use. Coffee beans can maintain their flavour for up to 4 weeks when stored in an airtight container.

Alternatively, buy ground coffee specifically for espresso use and keep it sealed.

Check that the grind is right for espresso:

- The ideal grind should have a texture like that of table salt: powder with a bit of grit.
- If the coffee grind is too fine, water cannot flow through it, even under high pressure. These grinds resemble powder when rubbed between the fingers.
- If the coffee grind is too coarse, the water flows through it too quickly, resulting in a less flavourful extraction. These grinds resemble coarse sea salt.

Let's make a coffee

TURNING THE PRIMA LATTE ESPRESSO MACHINE ON

1. Ensure that the Prima Latte Espresso Machine is plugged into an appropriate electrical outlet.
2. Press the Power button “” located on the front of the unit. The LED on the button illuminates and pulses to indicate warming up. When ready, the button remains fully illuminated and enters Standby mode.

FILLING THE WATER RESERVOIR

1. Fill the water reservoir with water (see Figure 1). You may use a pitcher or remove it from the unit and then fill it under a tap. Fill the reservoir with the desired amount of water below the “MAX” level. Always use room temperature water to fill the water reservoir; DO NOT use warm or hot water. Recommend using filtered water to improve the coffee taste. Filtered water is also recommended in areas with hard water.

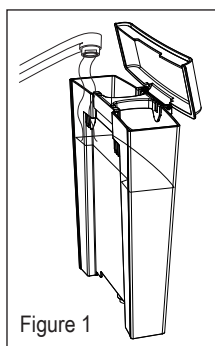

2. Ensure the water reservoir lid is closed after refilling. If you have removed the reservoir from the unit for filling, then close the lid before replacing the reservoir back on the unit to prevent spillage.

NOTE: If no water is in the reservoir, the unit's pump auto shuts off after approximately 20 seconds.

FILLING THE MILK TANK

1. To prepare a cappuccino or latte, gently pull the milk tank forward holding onto the middle of the tank (see Figure 2), then remove the milk frothing system by pressing the lid release button at the side.
2. Pour the desired quantity of cold milk you estimate you will need, ensuring it is below the “MAX” level on the tank (see Figure 3). Filling to the “MIN” mark will allow one of any milk beverages to be made.
3. Refit the milk frothing system by pressing it back in place until the lid release button clicks to lock. Then, slide the milk tank back onto the unit. You should feel the milk tank click into position.
4. If any milk remains in the tank after you make your beverage, you can store it in the refrigerator. Typically, milk should be consumed within 3 days of opening.

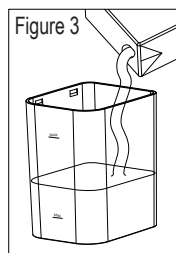
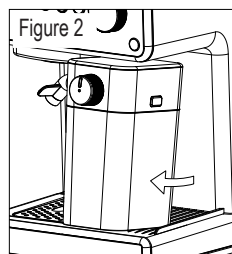

NOTE: The milk path should be flushed after each use. Refer to “Frothing System Cleaning”.

You can use all milk types and achieve great results, but for best results with non-dairy milk, we recommend using specific barista variations.

NOTE: When inserting the milk tank you should feel the milk tank click into position. The best grip to remove and insert is holding at the middle of the milk tank.

If the milk tank is attached after the machine has warmed up, the Power LED will pulse while the milk frothing system does a top-up warm up.

NOTE: If the milk tank is not attached to the unit, only the espresso and manual espresso functions will work. If the latte, cappuccino, or manual milk froth

functions are selected, the function will not proceed, and the Start/Stop button “▷X” LED will flash.

Using the group handle

CHOOSING THE FILTER

Select the filter to be used as follows:

1. **FOR A SINGLE ESPRESSO SHOT:** Use the single filter basket.



2. **FOR A DOUBLE ESPRESSO SHOT:** Use the double filter basket.

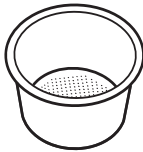

PLACING THE FILTER IN THE GROUP HANDLE

1. Firmly press the filter into the Group Handle until it clicks.

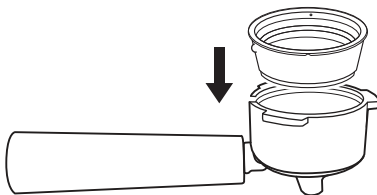

2. To remove the filter from the Group Handle for cleaning, use your finger to grip the edge of the filter and push it upward until it detaches.

WARNING: Ensure the filter has cooled down before removing it from the Group Handle.

FILLING WITH COFFEE

USE GROUND COFFEE:

1. Fill the filter with fresh, finely ground espresso coffee, leaving about 3mm from the rim (DO NOT overfill).

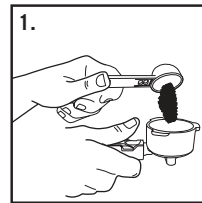

2. Using the tamping part of the scoop, firmly press the coffee grounds down to ensure they are compact and even. The top of the straight section of the tamp should be approximately level with the rim of the filter to ensure that your espresso grounds are compact and level.

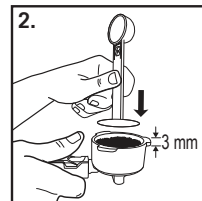

3. Wipe away any excess coffee from the rim to ensure a proper fit under the unit's brew head.

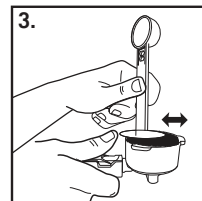

PLACING THE GROUP HANDLE

1. Place the Group Handle under the unit's brew head.

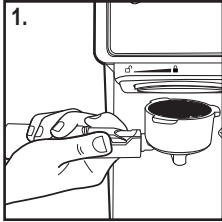

2. Align the handle with the unit's open lock icon "☞" to fit into the groove.

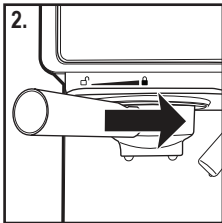

3. Gradually turn the handle to the right until it is aligned with the unit's full lock symbol "🔒", and the Group Handle facing directly towards you.

Make sure you avoid accidentally pressing any of the buttons.

CAUTION: The Group Handle MUST be in the locked lock "🔒" position before brewing.

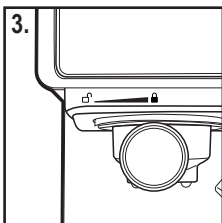

PLACING THE CUP

1. For any milk-based beverages, adjust the adjustable cup platform so that the cup's rim is close to the milk spout by moving it to whichever of the height adjustment slots is most suitable.
2. If you use a larger cup to brew cappuccino or latte, keep the adjustable cup platform on the drip tray.
3. For tall cups and "To Go Cups," both the drip tray plate and the drip tray can be removed. When both are taken out and the cup is placed directly on the machine's base, the maximum height for a cup is approximately 140 mm.

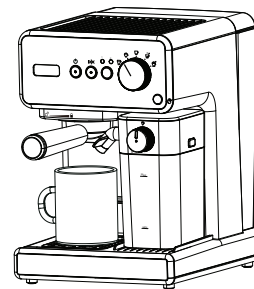
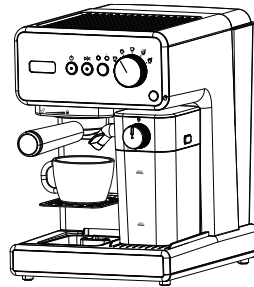

NOTE: When brewing a cappuccino or latte, make sure to use the frothing tube lever to position the frothed milk dispensing tube inside the cup's rim.

Select the function

PREPARING ESPRESSO

If you are brewing only espresso, it isn't necessary to attach the milk tank. When the milk tank is not attached, the Prima Latte Espresso Machine will only allow you to select espresso buttons.

1. Use the Mode Selection knob to select the Espresso option “☕”.



2. Do one of the following:

- Press the Shot Selection button to choose option (1) for brewing a single-shot espresso. The indicator LED (1) will illuminate to signify a single-shot espresso.

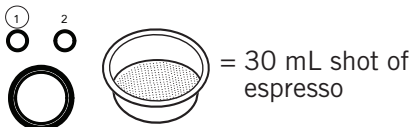

- Press the Shot Selection button to choose option (2) for brewing a double-shot espresso. The indicator LED (2) will illuminate to signify a double-shot espresso.

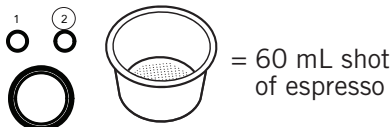

3. Press the Start/Stop button “▷X” to begin brewing. The LED on the button will illuminate and pulse on and off to signal that brewing is in progress.



4. The machine will begin brewing the espresso based on your selection. Once the brewing process is complete, it will automatically stop and go into Standby mode. Your delicious espresso is now ready to enjoy!

NOTE: If you want to brew less coffee than the preset amount, press the Start/Stop button “▷X” at any time during the brewing process to stop when you reach your desired amount of coffee.

To brew manually, use the Mode Selection knob to select the Manual Shot option “☕”, and then press the Start/Stop button “▷X” to begin brewing. When you have the desired amount of espresso, press the Start/Stop button “▷X” again to stop the machine.

If not manually stopped in this mode, the unit will automatically stop brewing after 200ml (or around 1 minute).

PREPARING CAPPUCCINO

1. Remove the milk tank from the Prima Latte Espresso Machine and add the amount of cold milk you need into the tank. Place the milk tank back in place. Refer to the “Filling the Milk Tank” section for detailed instructions.
2. Turn the Milk Tank knob to the to the vertical Milk Froth position.

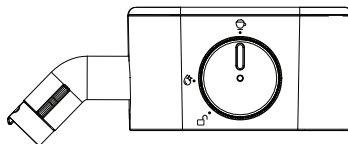

3. Use the Mode Selection knob to select the Cappuccino option “☕”.



4. Do one of the following:

- Press the Shot Selection button to choose option (1) for brewing a small cappuccino. The indicator LED (1) will illuminate when a small cup of cappuccino is selected.

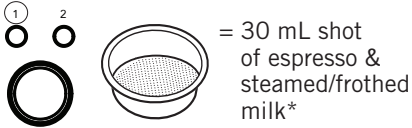

- Press the Shot Selection button to choose option (2) for brewing a large cappuccino. The indicator LED (2) will illuminate when a large cup of cappuccino is selected.

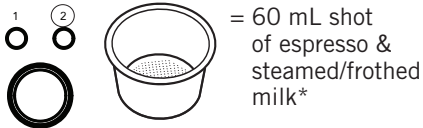

5. Press the Start/Stop button “▷×” to begin brewing. The LED on the button will illuminate and pulse on and off to signal that brewing is in progress.



6. The machine will begin brewing the cappuccino based on your selection. Once the brewing process is complete, it will automatically stop and go into Standby mode.

Your delicious cappuccino is now ready to enjoy!

PREPARING LATTE

1. Remove the milk tank from the Prima Latte Espresso Machine and add the amount of cold milk you need into the tank. Place the milk tank back in place. Refer to the “Filling the Milk Tank” section for detailed instructions.
2. Turn the Milk Tank knob to the vertical Milk Froth position.

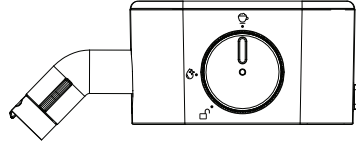

3. Turn the Mode Selection knob to select the Latte option “☕”.



4. Do one of the following:

- Press the Shot Selection button to choose option (1) for brewing a small latte. The indicator LED (1) will illuminate when a small cup of latte is selected.

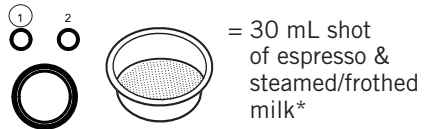

- Press the Shot Selection button to choose option (2) for brewing a large latte. The indicator LED (2) will illuminate when a large cup of latte is selected.

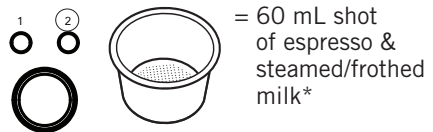

* See table page 6 for suggested cup size/volume per beverage.

5. Press the Start/Stop button “▷X” to begin brewing. The LED on the button will illuminate and pulse on and off to signal that brewing is in progress.



6. The machine will begin brewing the latte based on your selection. Once the brewing process is complete, it will automatically stop and go into Standby mode.

Your delicious latte is now ready to enjoy!

PREPARING FROTHED MILK

The Prima Latte Espresso Machine also allows you to prepare frothed milk alone. To add more foam to your beverage or to prepare frothed milk for other drinks like a macchiato, hot chocolate, or chai latte, do the following:

1. Remove the milk tank from the Prima Latte Espresso Machine and add the amount of cold milk you need into the tank. Place the milk tank back in place. Refer to the “Filling the Milk Tank” section for detailed instructions.
2. Turn the Milk Tank knob to the vertical Milk Froth position.

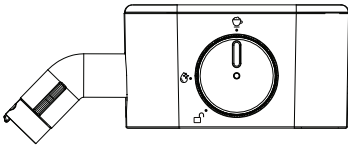

3. Use the Mode Selection knob to choose the Manual Milk Frothing option “☕”. When the Manual Milk Frothing option “☕” is selected, the Shot Selection option (1 or 2) is inactive.



4. Press the Start/Stop button “▷X”. The LED on the button will illuminate and pulse on and off to signal that frothing is in progress.

5. When you have the desired amount of frothed milk, press the Start/Stop button “▷X” again to stop the machine.

The unit will automatically stop dispensing frothed milk after 45 seconds if not manually stopped.

AFTER PREPARING YOUR BEVERAGES WITH MILK

NOTE: After you finish preparing your beverage with milk, always remember to flush the milk frothing system after each use. This can also be done with milk in the milk tank (see Frothin System Cleaning – with Milk in Tank).

After flushing the milk system, you have two options for handling the milk tank: either store the unit’s milk tank directly in the refrigerator for future use or dispose of any leftover milk.

AUTO-OFF FEATURE

After 15 minutes of inactivity, the Prima Latte Espresso Machine automatically turns off. When the unit is turned off, all LED indicators are turned off and inactive. Press the Power button “⏻” to awaken the unit.

After use, the unit should be turned off by pushing “⏻”. Leaving it in “Auto shut off” mode is not recommended for extended periods. Also, when not using the machine for longer periods, unplugging or turning off the electrical outlet is recommended.

Cleaning your machine

The cleaning LED will remain illuminated when your machine is ready for a cleaning cycle. Always turn the power off, unplug, and allow it to cool before removing parts for cleaning.

CLEANING THE DRIP TRAY

Empty the drip tray as needed. If the red Drip Tray Water Level Float is visible through the adjustable cup platform, remove it (see “Using the Adjustable Cup Platform”) and carefully empty the drip tray. The drip tray can be lifted by gripping its handle.

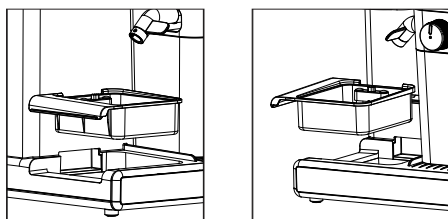

Additionally, clean the drip tray and adjustable cup platform weekly using warm water and a small amount of mild detergent. Rinse and dry them thoroughly afterward.

FROTHING SYSTEM CLEANING – WITH MILK IN TANK

It is important to flush the milk frothing system after each use.

NOTE: The cycle to flush the milk frothing system runs for approximately 30 seconds.

1. Ensure the milk tank and frothing system are properly attached.
2. Place a large empty cup (at least 325 mL capacity) under the froth dispensing tube.
3. Turn the milk tank knob anti-clockwise until it clicks into the clean position “☺”.

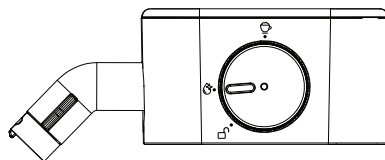

4. Press the Clean button “☺” once to activate the clean function. The Prima Latte Espresso Machine will release steam through the froth dispensing tube. When no more water is coming out of the tube, the cycle has completed and the Clean icon “☺” will turn off. Dispose of the water in the cup.
5. Rotate the Milk Tank knob back to the Froth position. This is critical to ensure correct operation for the next beverage.

CLEANING THE MILK TANK AND FROTHING SYSTEM

Although leftover milk can be stored in the milk tank in the refrigerator, it is important to manually clean the tank and frothing system regularly to avoid clogging and residue build-up and to maintain frothing performance.

1. Remove the milk tank & frothing system by gently pulling forward. The best grip is at the middle of the milk tank (Figure 1).

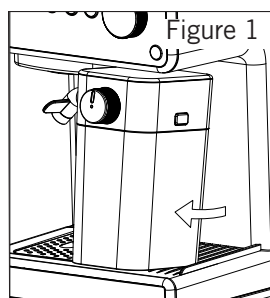

2. Remove the frothing system from the top of the tank using the lid release button at the side.

- Remove all parts from the frothing system (Figure 2): the milk dispensing tube, the straw, the milk tank knob, and the steam nozzle.

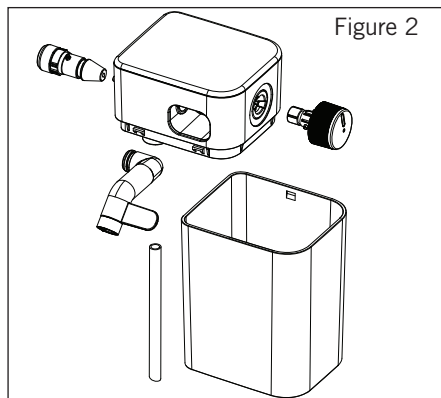

Remove the milk tank knob by turning it to the unlock icon (Figure 3).

Then pull the knob towards you to detach it. Once it is removed, make sure to rinse the ventilation hole in warm, soapy water.

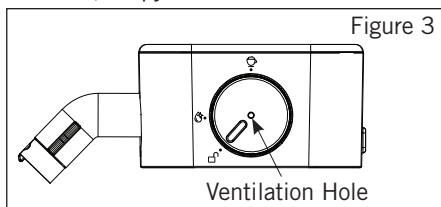

You will find the unlock and lock positions of the steam nozzle at the back of the milk tank (Figure 4). Unlock to remove and remember to lock it again when reattaching it to the milk tank after cleaning.

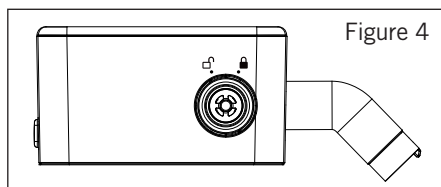

- Dispose of any milk, then wash the milk tank and frothing system parts thoroughly with warm, soapy water. Rinse and dry them well. DO NOT use abrasive cleaners and scouring pads, as they will scratch the finish.

NOTE: We recommend hand washing all parts, even if some parts are dishwasher safe (see p. 5).



CLEANING THE BREW HEAD, THE GROUP HANDLE AND FILTERS

- Press the Power button “” to turn the Prima Latte Espresso Machine OFF. The unit is off when the LED on the Power button is off. Unplug the power cord from the electrical outlet.

CAUTION: Some metal parts may still be hot. DO NOT touch them with your hands until they cool down.

- Remove the Group Handle and discard the used coffee grounds. Thoroughly wash both the Group Handle and filter with warm, soapy water, then rinse and dry them well.

NOTE: DO NOT wash the Group Handles and filters in the dishwasher. For instructions on how to deep clean them, see the “Group Handle and Filters Deep Cleaning Procedure” section.

- Use a damp cloth or paper towel to wipe the lower part of the brew head in the unit, removing any leftover coffee grounds.
- Place the Group Handle without the filter back into the brew head and securely lock it in place.
- Place a large, empty cup (at least 325 mL capacity) beneath the Group Handle.
- Plug the power cord into the electrical outlet. Press the Power button “” to turn the unit ON. The LED on the Power button will illuminate.
- Press the Shot Selection button to select the double shot (2) option. The indicator LED (2) will illuminate.
- Turn the Mode Selection knob to the Espresso option “”.
- Press the Start/Stop button “” to allow the unit to brew with water until it stops automatically.
- Empty the water from the cup.

CLEANING THE WATER TANK

If water is left in the water tank for an extended period, it is recommended that it is emptied and cleaned.

1. Dispose of the remaining water by removing the water tank, detaching the lid, and turning it upside down over the sink.
2. Thoroughly wash the water tank, handle, and lid with warm, soapy water. Ensure they are well-rinsed and dried.

CAUTION: DO NOT immerse main body of the appliance or power cord and plug in water or any other liquid.

CLEANING THE PRIMA LATTE ESPRESSO MACHINE

Clean the housing with a soft, damp cloth. Avoid using abrasive cleaners or scouring pads, as they can scratch the finish.

DESCALING

Build-up of mineral deposits in the Prima Latte Espresso Machine will affect the operation of the appliance. Your appliance needs descaling when you begin to notice an increase in the time required to brew espresso, or when there is excessive steaming. Also, you may notice a build-up of white deposits on the surface of the brew head.

The frequency of cleaning depends upon the hardness of the water used. The following table gives the suggested cleaning intervals.

SUGGESTED DESCALING INTERVALS

Type of Water	Cleaning Frequency
Soft Water (Filtered Water)	Every 80 Brew Cycles
Hard Water (Tap Water)	Every 40 Brew Cycles

Use Sunbeam Eco-friendly Descaler to descale your Prima Latte Espresso Machine. To purchase, contact your retailer or the Sunbeam Customer Service team (details are on the back page of this User Guide).

Alternatively, use a descaling solution comprising 50% white vinegar and 50% clean water.

To descale the unit, use the Deep Cleaning Procedure described on the next page.

DEEP CLEANING NOTIFICATION

After 200 beverage cycles, the Cleaning Indicator LED lights up brightly to signal that a cleaning cycle is needed.

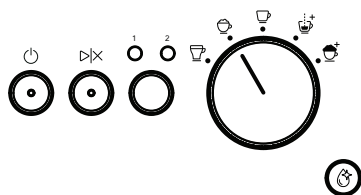

The Cleaning Indicator LED will remain on as a notification until the cleaning procedure is completed.

1. If you brew another espresso, latte, or cappuccino, the Cleaning Indicator LED will turn off momentarily but start flashing after the brew is complete.
2. The Cleaning Indicator LED will turn off when the Prima Latte Espresso Machine is powered off.
3. The Cleaning Indicator LED will turn off when the unit powers down and goes into sleep mode.

DEEP CLEANING PROCEDURE

The deep cleaning procedure includes descaling of internal parts and frothing system cleaning.

You can use a Sunbeam Eco-friendly Descaler or alternatively, create a descaling solution of 50% white vinegar and 50% clean water.

1. Pour the descaling solution into the water tank and allow it to fully mix or dissolve.
2. Rotate the Milk Tank knob until it clicks into the clean position “☺”. Place a large cup (at least 475 mL capacity) under the frothed milk dispensing tube.
3. Press the Clean button “☺” for 5 seconds to activate the deep clean mode. The LED on the Start/Stop button will begin to flash.
 - Press the Start/Stop button. The pump will turn on and off multiple times for about 7.5 minutes. The cleaning light will then turn off, indicating the cleaning process is completed.
4. Pour out any remaining solution from the water tank and fill with clean water up to the “MAX” level line.
5. Repeat Steps 2 - 4 as necessary, using only tap water to remove any remaining traces of the descaling solution.

NOTE: Make sure to turn the Milk Tank Knob back to the vertical Milk Froth position after cleaning. This is critical to ensure the next beverage can be brewed correctly.

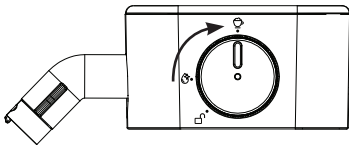

GROUP HANDLE AND FILTERS DEEP CLEANING

Deep clean your group handle and filters every 90 days for optimal brewing performance and to keep your coffee tasting great. Follow these disassembly instructions and rinse the pieces in a large bowl of warm water. Once rinsed thoroughly, wipe dry and reassemble.

1. To remove the filter from the Group Handle, use your finger to grip the edge of the filter and push it upward until it detaches.
2. Wash the Group Handle and filters with warm soapy water. Make sure to rinse and dry them well.
3. Reassemble by firmly pressing the filter into the Group Handle until you hear it click.

NOTE: DO NOT store the Group Handle in the brew head. This can adversely affect the seal between the brew head and the Group Handle during espresso brewing.

Troubleshooting guide

PROBLEM	CAUSES	SOLUTIONS
Coffee does not come out.	• No water in reservoir.	• Add water.
	• Unit is not primed.	• Prime the unit (refer to “Important - Prime the Prima Latte Espresso Machine” section).
	• Coffee grind is too fine.	• Grind medium ground coffee.
	• Too much coffee in the filter.	• Fill filter with less coffee.
	• Appliance was not turned on or plugged in.	• Plug unit into electrical outlet and turn it on.
	• Coffee has been tamped/ compressed too much.	• Refill filter basket with coffee and TAMP GENTLY.
Coffee comes out around the edge of the Group Handle.	• Group Handle not rotated to full lock position.	• Rotate filter holder to full lock position.
	• Coffee grounds around the filter basket rim.	• Wipe off rim.
	• Too much coffee in the filter.	• Fill with less coffee.
Coffee comes out too quickly.	• Ground coffee is too coarse.	• Use a finer grind.
	• Not enough coffee in filter.	• Fill filter with more coffee.
Coffee is too weak.	• Using single filter for double shot of espresso.	• Use double filter for double shot of espresso.
	• Ground coffee is too coarse.	• Use a finer grind.
Coffee is not hot enough.	• Cup too cold.	• Warm up cup with hot water before use.
Coffee puck is wet or hard to remove after brewing.	• Normal for Dual Wall filters.	• Leave the handle to sit on the drip tray until the water is absorbed. Scrape out the coffee grinds with a teaspoon and rinse.

Troubleshooting guide

PROBLEM	CAUSES	SOLUTIONS
Milk is not foamy after frothing or it is not coming out of the frothing tube.	• Ran out of steam.	• Ensure there is enough water in the water reservoir.
	• Milk is not cold enough.	• Chill milk prior to making cappuccino or latte.
	• Frothing system is blocked.	• Follow the instructions to clean the frothing system.
	• Milk tank is not in position.	• Check that the milk tank has clicked into position and is attached properly to fully engage with the espresso maker.
	• Milk Tank Knob is not in the vertical position.	• Rotate the knob to the vertical froth position.
	• Blocked vent hole in the Milk Tank Knob.	• Remove knob and wash or soak in warm soapy water.
The control panel LEDs are flashing.	• Start/Stop button “▷X” was pressed prior to the LEDs solidly illuminated to indicate that the machine is ready.	• Wait until the LEDs are solidly illuminated to indicate the machine is ready.
1 Shot and 2 Shot LEDs blink together	• Low water in reservoir.	• Refill water reservoir and run priming procedure (refer to “Important - Prime The Prima Latte Espresso Machine” section). Note: It is normal to see some steam/water coming out of the Frothed Milk Dispensing Tube.
Cleaning LED remains on.	• Your machine is letting you know it is ready for a cleaning cycle to be performed.	• Perform cleaning cycle (see the “Cleaning Notification” section).

12 Month Warranty

This Sunbeam product is covered by a 12 month replacement or repair warranty, which is in addition to your rights under the Australian Consumer Law (if your product was purchased in Australia) or New Zealand Consumer Guarantees Act (if your product was purchased in New Zealand).

Upon receipt of your claim, Sunbeam will seek to resolve your difficulties or, if the product is defective, advise you on how to obtain a replacement or refund.

To assist us in managing warranty claims, we recommend you register your product as soon as practicable after purchase, on our Sunbeam website and uploading a copy of your original receipt. View the Support section of the Sunbeam website.

In order to make a claim under our warranty, you must have the original proof of purchase documentation for the product and present it when requested (if not already uploaded to our website).

Under our warranty, should your product develop any defect within 12 months of purchase because of faulty materials or workmanship, we will replace or repair it, at our discretion, free of charge. A product presented for repair may be replaced by a refurbished product of the same type rather than being repaired. Refurbished parts may be used to repair the product.

Our replacement or repair warranty only applies where a defect arises as a result of faulty material or workmanship during the warranty period. Our warranty does not cover misuse or negligent handling (including damage caused by failing to use the product in accordance with this instruction booklet), accidental damage, or normal wear and tear.

Our warranty does not:

- cover freight or any other costs incurred in making a claim, consumable items, accessories that by their nature and limited lifespan require periodic renewal (such as filters and seals) or any consequential loss or damage; or
- cover damage caused by:
 - power surges, power dips, voltage supply problems, or use of the product on incorrect voltage;

- servicing or modification of the product other than by Sunbeam or an authorised Sunbeam service centre;
- use of the product with other accessories, attachments, product supplies, parts or devices that do not conform to Sunbeam specifications; or
- exposure of the product to abnormally corrosive conditions; or
- extend beyond 3 months if the product is used in commercial, industrial, educational or applications (other than for internal or own use in an office environment).

The benefits given to you by our warranty are in addition to other rights and remedies under law in relation to the product.

In Australia our goods come with guarantees that cannot be excluded under the Australian Consumer Law. You are entitled to a replacement or refund for a major failure and for compensation for any other foreseeable loss or damage. You are also entitled to have the goods repaired or replaced if the goods fail to be of acceptable quality and the failure does not amount to a major failure.

Our goods also come with guarantees that cannot be excluded under the New Zealand Consumer Guarantees Act.

If your warranty claim is not accepted, we will inform you and if requested to do so by you, repair the product provided you pay the usual charges for such repair. You will also be responsible for all freight and other costs.

Should your product require repair or service after the warranty period, contact your nearest Sunbeam service centre. For a complete list of Sunbeam's service centres, visit our website or call our customer service line for advice on 1300 881 861 in Australia, or 0800 786 232 in New Zealand.

Should you experience any difficulties with your product during the warranty period, please contact our customer service line for advice on 1300 881 861 in Australia, or 0800 786 232 in New Zealand.

Australia

www.sunbeam.com.au
1300 881 861

New Zealand

www.sunbeam.co.nz
0800 786 232

Need help with your appliance?

Contact our customer service team or visit our website for information and tips on getting the most from your appliance.

Australia | visit www.sunbeam.com.au
| phone 1300 881 861

New Zealand | visit www.sunbeam.co.nz
| phone 0800 786 232

Newell Australia Pty Ltd. ABN 68 075 071 233

Sunbeam is a registered trade mark.

Made in China to Sunbeam's specification.

Due to minor changes in design or otherwise,
the product you buy may differ slightly from the one shown here.

Approved by the appropriate electrical regulatory authorities.

©Copyright Sunbeam 2025.

08/25