

Contents

1	Instructions	4
1.1	General safety instructions	4
1.2	Manufacturer liability	7
1.3	Appliance purpose	7
1.4	Identification plate	7
1.5	This user manual	7
1.6	Disposal	8
1.7	How to read the user manual	9
2	Description	10
2.1	General Description	10
2.2	Symbols	10
2.3	Available accessories	11
3	Use	12
3.1	Instructions	12
3.2	First use	12
3.3	Using the cooktop	12
4	Cleaning and maintenance	15
4.1	Instructions	15
4.2	Cleaning the appliance	15
5	Installation	17
5.1	Clearances above and around domestic appliances	17
5.2	Safety instructions	18
5.3	Positioning in the counter top	19
5.4	Mounting	23
5.5	Gas connection	24
5.6	Adaptation to different types of gas	27
5.7	Electrical connection	29
5.8	Instructions for the installer	30

These instructions apply only for the destination countries listed on the appliance's data plate.
This is a class 3 built in cooktop.

We advise you to read this manual carefully, which contains all the instructions for maintaining the appliance's aesthetic and functional qualities.

For further information on the product: www.smeg.com



Instructions

1 Instructions

1.1 General safety instructions

Risk of personal injury

- During use the appliance and its accessible parts become very hot. Never touch the heating elements during use.
- Never try to put out a fire or flames with water: turn off the appliance and smother the flames with a fire blanket or other appropriate cover.
- This appliance may be used by children aged at least 8 and by people of reduced physical, sensory or mental capacity, or lacking in experience in the use of electrical appliances, as long they are supervised or instructed by adults who are responsible for their safety.
- Children must not be allowed to play with the appliance.
- Keep children under eight years of age at a safe distance if they are not constantly supervised.
- Do not allow children younger than 8 years old to come near the appliance when in operation.
- Cleaning and maintenance must not be carried out by unsupervised children.
- Make sure that the flame-spreader crowns are correctly positioned in their housings with their respective burner caps.
- Fats and oils can catch fire if they overheat. Do not leave the appliance unattended while preparing foods containing oils or fats. If fats or oils catch fire, never put water on them. Place the lid on the pan and turn off the relevant cooking zone.
- The cooking process must always be monitored. Short cooking processes must be monitored continuously.
- When in use, do not place metal objects, such as dishes or cutlery, on the surface of the cooktop as they may overheat.
- Do not insert pointed metal objects (cutlery or utensils) into the slots in the appliance.



- DO NOT SPRAY AEROSOLS IN THE VICINITY OF THIS APPLIANCE WHILE IT IS IN OPERATION.
- DO NOT USE FLAMMABLE MATERIALS NEAR THIS APPLIANCE.
- Switch the appliance off immediately after use.
- DO NOT MODIFY THIS APPLIANCE.
- Before carrying out any work on the appliance (installation, maintenance, positioning or moving), wear personal protective equipment.
- Before carrying out any work on the appliance, disconnect the mains power supply.
- Have authorised persons carry out installation and assistance interventions according to the standards in force.
- Do not try to repair the appliance yourself or without the intervention of authorised persons.
- Do not pull the cable to remove the plug.
- If the power supply cable is damaged, contact technical support immediately and they will replace it.

Risk of damaging the appliance

- Do not seat on the appliance.
- Do not use steam jets to clean the appliance.
- Do not obstruct ventilation openings and heat dispersal slots.
- Never leave the appliance unattended during cooking operations in which fats or oils could be released that could overheat and catch fire. Be very careful
- Never leave objects on the cooking surface.
- DO NOT USE THIS APPLIANCE AS A SPACE HEATER.
- DO NOT PLACE ARTICLES ON OR AGAINST THIS APPLIANCE.
- Do not use plastic kitchenware or containers when cooking food.
- The cooking vessels or griddle plates should be placed inside the perimeter of the cooktop.
- All cookware must have smooth, flat bottoms.
- If any liquid does boil over or spill, remove the excess from the cooktop.
- Take care not to spill acidic substances such as lemon juice or vinegar onto the cooktop.



Instructions

- Do not put empty pans or frying pans on switched on cooking zones.
- Do not use steam jets to clean the appliance.
- Do not use rough or abrasive materials or sharp metal scrapers.
- Do not use cleaning products containing chlorine, ammonia or bleach on steel parts or parts with metallic surface finishes (e.g. anodizing, nickel- or chromium-plating).
- Do not wash the removable components such as the cooktop trivets, flame-spreader crowns and burner caps in a dishwasher.
- All servicing and maintenance are to be completed by the manufacturer's authorised persons only.
- Installation with flexible hose must be carried out so that the length of the piping does not exceed 2 metres when fully extended as regards flexible steel hoses and 1.5 metres in case of rubber hoses.
- The hoses should not come into contact with moving parts and should not be crushed in any way.
- If required, use a pressure regulator that complies with current regulations.
- After carrying out any operation, check that the tightening torque of gas connections is between 10 Nm and 1.5 Nm.
- At the end of the installation, check for any leaks with a soapy solution, never with a flame.
- Have the electrical connection performed by authorised persons.

Installation

- THIS APPLIANCE **MUST NOT BE INSTALLED** IN BOATS OR CARAVANS.
- The appliance must not be installed on a stand.
- Position the appliance into the cabinet cutout with the help of a second person.
- The gas connection should be carried out by authorised persons.
- The appliance must be connected to earth in compliance with electrical system safety standards.
- Use cables withstanding a temperature of at least 90°C.
- The tightening torque of the screws of the terminal supply wires must be 1.5 - 2 Nm.



- In case of service, contact your nearest service agent distributor listed in the warranty card or www.smeg.au | 02 8667 4888 | Annual service is recommended.

For this appliance

- Do not obstruct ventilation openings and heat dispersal slots.
- Do not insert pointed metal objects (cutlery or utensils) into the slots in the appliance.
- Do not use the appliance to heat rooms for any reason.
- The appliance is not designed to operate with external timers or with remote-control systems.

1.2 Manufacturer liability

The manufacturer declines all liability for damage to persons or property caused by:

- use of the appliance other than the one envisaged,
- non-observance of the user manual provisions,
- tampering with any part of the appliance,
- the use of non-original spare parts.

1.3 Appliance purpose

This appliance is intended for cooking food in the home environment. Every other use is considered improper.

1.4 Identification plate

The identification plate bears the technical data, serial number and brand name of the appliance. Do not remove the identification plate for any reason.

1.5 This user manual

This user manual is an integral part of the appliance and must therefore be kept in its entirety and in an accessible place for the whole working life of the appliance. Read this user manual carefully before using the appliance.



Instructions

1.6 Disposal



This appliance must be disposed of separately from other waste (Directives 2002/95/EC, 2002/96/EC, 2003/108/EC). The appliance does not contain substances in quantities sufficient to be considered hazardous to health and the environment, in accordance with current European directives.

To dispose of the appliance:

- Cut the power supply cable and remove it along with the plug.



Power voltage

Danger of electrocution

- Disconnect the mains power supply.
 - Unplug the power cable from the socket.
-
- Deliver the appliance to the appropriate recycling facility for electrical and electronic equipment waste, or deliver it back to the retailer when purchasing an equivalent product, on a one for one basis.

Our appliances are packaged in non-polluting and recyclable materials.

- Deliver the packing materials to the appropriate recycling facility.



Plastic packaging

Danger of suffocation

- Do not leave the packaging or any part of it unattended.
- Do not let children play with the plastic bags.



1.7 How to read the user manual

This user manual uses the following reading conventions:

Instructions



General information on this user manual, on safety and final disposal.

Description



Description of the appliance and its accessories.

Use



Information on the use of the appliance and its accessories, cooking advice.

Cleaning and maintenance



Information for proper cleaning and maintenance of the appliance.

Installation



Information for authorised persons: installation, operation and inspection.



Safety instructions



Information



Advice

1. Sequence of instructions for use.

- Standalone instruction.



2 Description

2.1 General Description

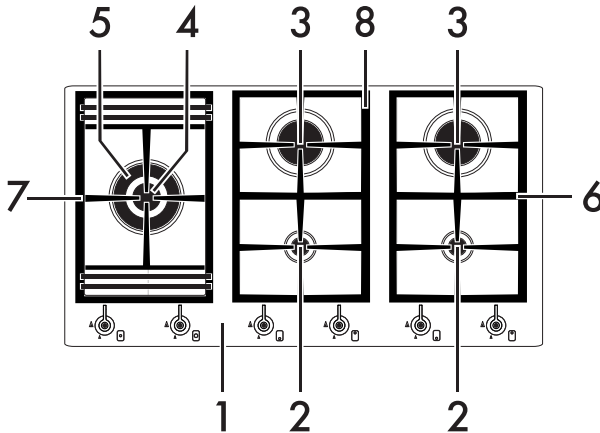

1. Control panel
2. Auxiliary Burner (AUX)
3. Reduced Rapid Burner (RR)
4. Ultra-rapid burner, internal crown (UR2 int.)
5. Ultra-rapid burner, external crown (UR2 ext.)
8. Right side trivet
7. Left side trivet
8. Central trivet

2.2 Symbols



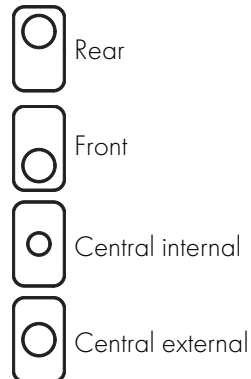

Cooking zones



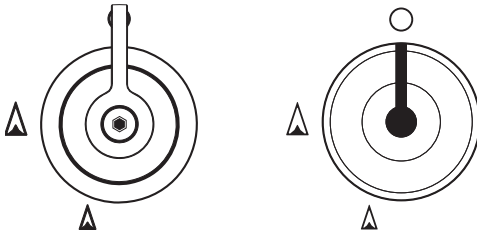

Burner knobs



Useful for lighting and adjusting the cooktop burners. Press and turn the knobs anti-clockwise to the value  to light the relative burners. Turn the knobs to the zone between the maximum  and minimum  setting to adjust the flame. Return the knobs to the  position to turn off the burners.

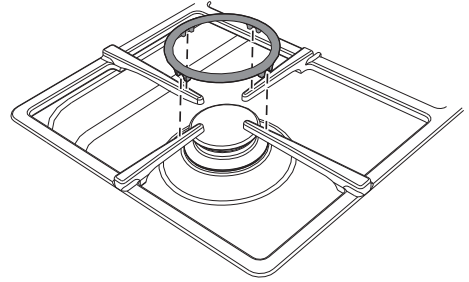

The ring reducer must be positioned above the cooktop trivet as shown in the figure above.

In any case, pans with a diameter greater than 28 cm must be used only on the Ultra-rapid burner (UR2).

This trivet can also be used with woks.

2.3 Available accessories

Raised trivet

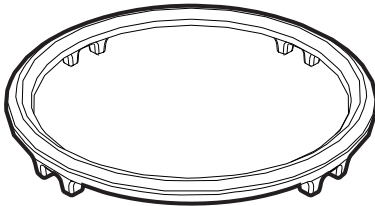

In order to prevent worktop damage and wear, a raised trivet is available to position underneath pans which exceed the diameters indicated in the "Cookware diameters" table in section "3.3 Using the cooktop".



3 Use

3.1 Instructions



Improper use Danger of burns

- Make sure that the flame-spreader crowns are correctly positioned in their housings with their respective burner caps.
- Oils and fat could catch fire if overheated. Be very careful.
- Do not leave the appliance unattended during cooking operations where fats or oils could be released.
- Do not spray any spray products near the appliance.
- Do not touch the appliance's heating elements when it is running. Leave them to cool before cleaning.
- Do not allow children younger than 8 years old to come near the appliance when in operation.



Improper use Risk of damage to surfaces

- Do not use aluminium foil to cover the burners or cooktop body.
- Cookware should be placed inside the perimeter of the cooktop.
- All cookware must have smooth, flat bottoms.
- If any liquid does boil over or spill, remove the excess from the cooktop.

3.2 First use

1. Remove any protective film from the outside or inside of the appliance, including accessories.
2. Remove any labels (apart from the technical data plate) from accessories.
3. Remove and wash all the appliance accessories (see 4 Cleaning and maintenance).

3.3 Using the cooktop

All the appliance's control and monitoring devices are located together on the front panel. The appliance is equipped with an electronic ignition device. Simply press the knob and turn it anti-clockwise to the maximum flame symbol, until the burner lights. If the burner does not light in the first 15 seconds, turn the knob to  and wait 60 seconds before trying again. After lighting, keep the knob pressed in for a few seconds to allow the thermocouple to heat up. The burner may go out when the knob is released: in this case, the thermocouple has not heated up sufficiently. Wait a few moments and repeat the operation. Keep the knob pressed in longer.



In case of an accidental switching off, a safety device will be tripped, cutting off the gas supply, even if the gas valve is open. Return the knob to  and wait at least 60 seconds before lighting it again.



Positioning the trivets

The trivets are provided unassembled on the cooktop. Follow the instructions as shown in the figure for correct trivet positioning.

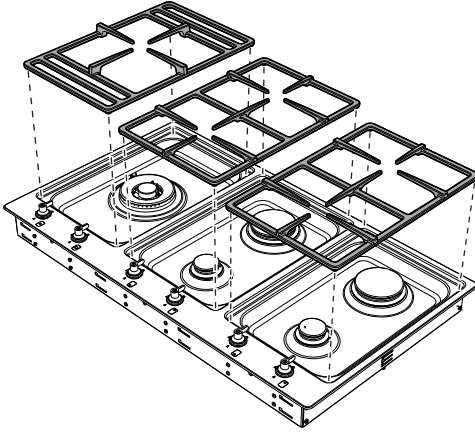

Correct positioning of the flame-spreader crowns and burner caps

Before lighting the cooktop burners, check that the flame-spreader crowns are correctly in place with their respective burner caps, making sure that the holes (A) in the burner are aligned with the plugs and thermocouples (B).

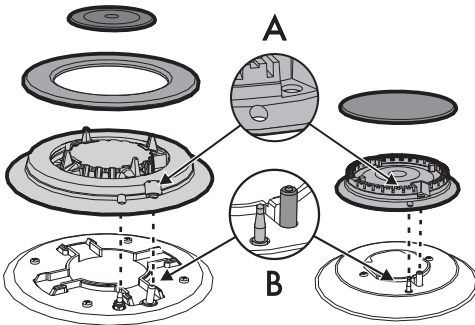

Practical tips for using the cooktop

For better burner efficiency and to minimise gas consumption, use pans with lids and of suitable size for the burner, so that flames do not reach up the sides of the pan. Once the contents come to the boil, turn down the flame far enough to ensure that the liquid does not boil over.



Cookware diameters:

- **AUX:** 12 - 16 cm.
- **RR:** 18 - 26 cm.
- **UR2 int. + ext.:** 18 - 26 cm.

Cookware diameters with raised trivet:

- **AUX:** 16 - 24 cm.
- **R:** 26 - 28 cm.

To prevent burns or damage to the cooktop or the counter top during cooking, all pans or griddles must be placed inside the perimeter of the cooktop.

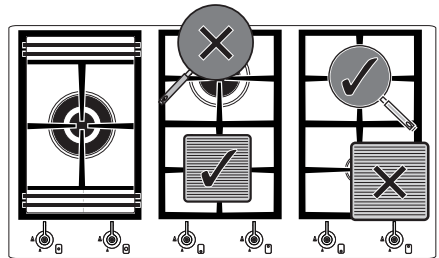

Always check that the control knobs are in the  (off) position when you finish using the cooktop.



Limitations on griddle use



A few precautions are necessary if you wish to use a griddle:

- Griddles must not protrude beyond the perimeter of the cooktop
- Aluminium griddles with Teflon anti-stick coating should be pre-heated for a maximum of 5 minutes in order to avoid damage to the appliance and the Teflon coating. After pre-heating, place the foodstuffs on the griddle to cook them; do not exceed 40 minutes of total use for the griddle
- Do not use griddles or plates to cook or heat food on the ultra-rapid burner (UR2)
- if one of the burners close to the wooden rear wall is an ultra-rapid burner (UR2), leave a gap of at least 160 mm between this wall and the edge of the griddle
- Do not allow the burner flames to extend beyond the edge of the griddle
- Leave a gap of at least 160 mm between the edge of the griddle and the side wall
- Do not place the griddle over more than one burner at the same time
- Never use the griddle for more than 40 minutes.



4 Cleaning and maintenance

4.1 Instructions



Improper use
Risk of damage to surfaces

- Do not use steam jets to clean the appliance.
- Do not use cleaning products containing chlorine, ammonia or bleach on steel parts or parts with metallic surface finishes (e.g. anodizing, nickel- or chromium-plating).
- Do not use rough or abrasive materials or sharp metal scrapers.
- Do not wash the removable components such as the cooktop trivets, flame-spreader crowns and burner caps in a dishwasher.

4.2 Cleaning the appliance

To keep the surfaces in good condition, they should be cleaned regularly after use. Let them cool first.

Ordinary daily cleaning

Always use only specific products that do not contain abrasives or chlorine-based acids.

Pour the product onto a damp cloth and wipe the surface, rinse thoroughly and dry with a soft cloth or a microfibre cloth.

Food stains or residues

Do not use steel sponges or sharp scrapers as they will damage the surfaces.

Use ordinary non-abrasive products with the aid of wooden or plastic utensils if necessary. Rinse thoroughly and dry with a soft cloth or a microfibre cloth.

Cooktop trivets

Remove the trivets and clean them with lukewarm water and non-abrasive detergent. Make sure to remove any encrustations. Dry them thoroughly and return them to the cooktop.



Continuous contact between the trivets and the flame can cause modifications to the enamel over time in those parts exposed to heat. This is a completely natural phenomenon which has no effect on the operation of this component.



Cleaning and maintenance

Flame-spreader crowns and burner caps

For easier cleaning, the flame-spreader crowns and the burner caps can be removed. Wash them in hot water and non-abrasive detergent. Carefully remove any encrustation, then wait until they are perfectly dry. Refit the flame-spreader crowns making sure that they are correctly positioned in their housings with their respective burner caps.

Knobs



Do not use aggressive products containing alcohol or products for cleaning steel and glass when cleaning the knobs, as these products could cause permanent damage.

The knobs should be cleaned with a soft cloth dampened with warm water, then dried carefully. They can easily be removed by pulling them upwards.

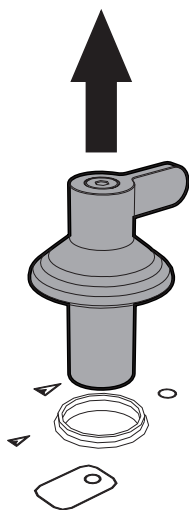

Igniters and thermocouples

For correct operation the igniters and thermocouples must always be perfectly clean. Check them frequently and clean them with a damp cloth if necessary. Remove any dry residues with a wooden toothpick or a needle.

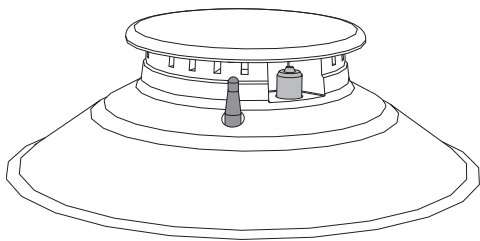

After cleaning, dry the appliance thoroughly to prevent water or detergent drips from interfering with its operation or creating unsightly marks.



5 Installation

5.1 Clearances above and around domestic appliances

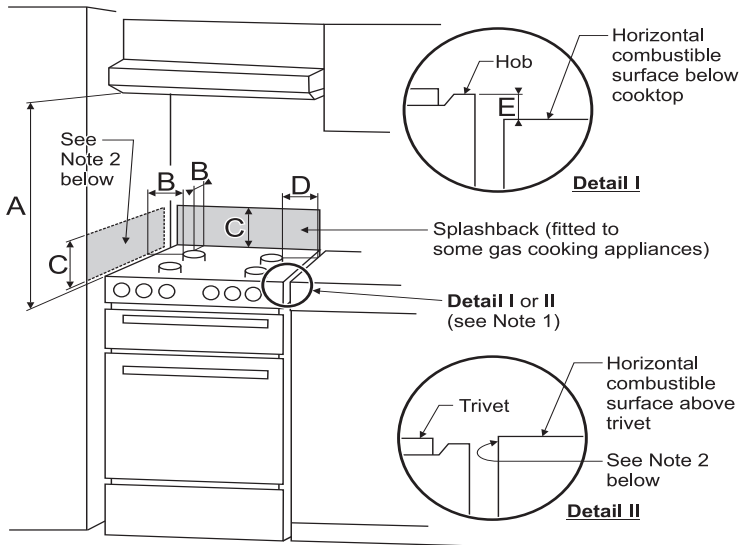

This appliance must be installed by an authorised person in accordance with this instruction manual, AS/NZS 5601.1 – Gas installations (installation and pipe sizing), local gas fitting regulations, local electrical regulations, Building Code of Australia and any other government authority.

Requirements

1. **Overhead clearances – (Measurement A)** Range hoods and exhaust fans shall be installed in accordance with the manufacturer's instructions. However, in no case shall the clearance between the highest part of the cooktop of the cooking appliance and a range hood be less than 600 or, for an overhead exhaust fan, 750. Any other downward facing combustible surface less than 600 above the highest

part of the cooktop shall be protected for the full width and depth of the cooking surface area in accordance with Clause 5.12.1.2. However, in no case shall this clearance to any surface be less than 450.

2. **Side clearances – (Measurements B & C)** Where B, measured from the periphery of the nearest burner to any vertical combustible surface, is less than 200, the surface shall be protected in accordance with Clause 5.12.1.2 to a height C of not less than 1.50 above the cooktop for the full dimension (width or depth) of the cooking surface area. Where the cooking appliance is fitted with a 'splashback', protection of the rear wall is not required.



Installation

3. Additional requirements for Freestanding and Elevated Cooking Appliances – (Measurements D & E)

Where D, the distance from the periphery of the nearest burner to a horizontal combustible surface is less than 200, then E shall be 10 or more, or the horizontal surface shall be above the trivet. See insets above.

Notes

1. Requirement 3 does not apply to a freestanding or elevated cooking appliance which is designed to prevent flames or the cooking vessels from extending beyond the periphery of the appliance.
2. The 'cooking surface area' is defined as that part of the appliance where cooking normally takes place and does not include those parts of the appliance containing control knobs.
3. For definition of cooktop, see Clause 1.4.64.
4. For definition of trivet, see Clause 1.4.109.
5. Consideration is to be given to window treatments when located near cooking appliances. See Clause 5.3.4.



The appliance connection point shall be accessible with the appliance installed.

5.2 Safety instructions



Heat production during appliance operation
Risk of fire

- Check that the piece of furniture material is heat resistant.
- Check that the piece of furniture has the required slots.

Veneers, adhesives or plastic coatings on adjacent furniture should be temperature-resistant ($>90^{\circ}\text{C}$), otherwise they might warp over time.



The minimum distance between a ventilation hood and the cooking surface must be at least the distance indicated in the ventilation hood installation instructions.

The minimum distances must also be respected for the edges of the cooktop on the back as indicated in the mounting illustrations.



5.3 Positioning in the counter top

i The following operation requires building and/or carpentry work and must therefore be carried out by a competent tradesman. Installation can be carried out on various materials such as masonry, metal, solid wood or plastic laminated wood as long as they are heat resistant (>90°C).

Fixing to the traditional built-in model support structure

Create an opening in the unit worktop with the dimensions shown in the figure.

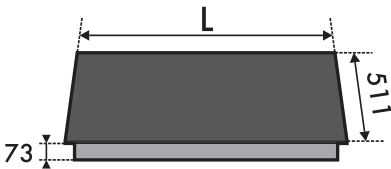

L (mm)	X (mm)	Y (mm)
899	878	490

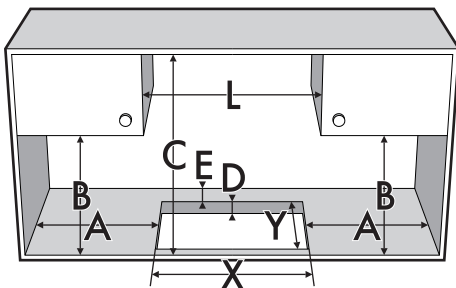

A (mm)	B (mm)	C (mm)	D (mm)	E (mm)
min 110	min 460	min 750	20 - 50	min 50

To prevent leakage of liquid between the frame of the cooktop and the worktop, carefully position the insulating seal provided before assembly (E).

1. Use light pressure to make the seal stick to the edge around the hole cut in the worktop.

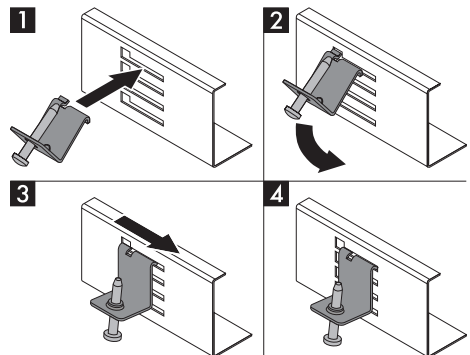
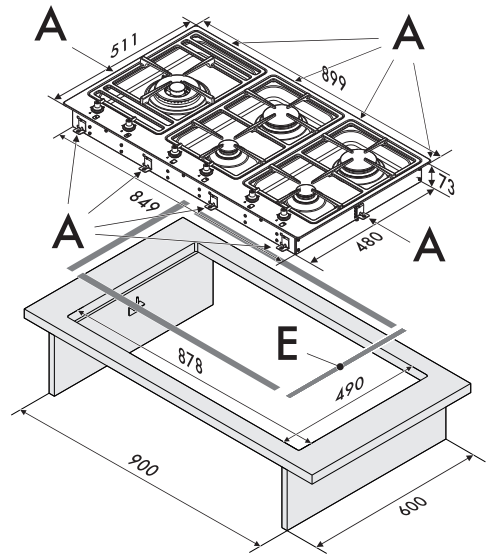



Installation

- Place the cooktop on the insulating seal and fix it to the supporting structure using the supplied screws and fastening brackets (A) so that the cooktop is perfectly flat.

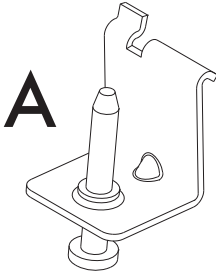

Fixing to the flush built-in model support structure

Create an opening with the dimensions shown in the figure in the work surface of the piece of furniture.

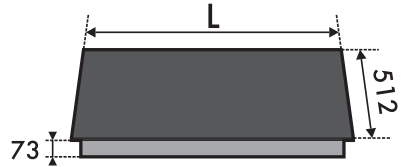

L (mm)	X (mm)	Y (mm)
900	490	878

- Carefully trim the surplus seal (B).

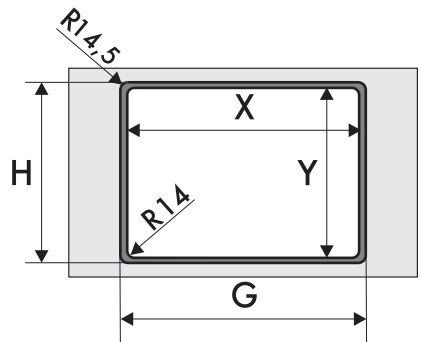
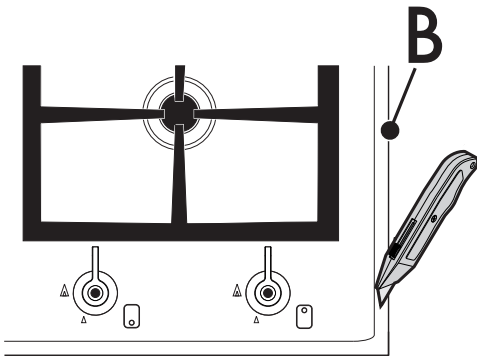

X (mm)	Y (mm)	G (mm)	H (mm)
490	878	901	513

 The brackets must be positioned only after placing the cooktop on the seal.

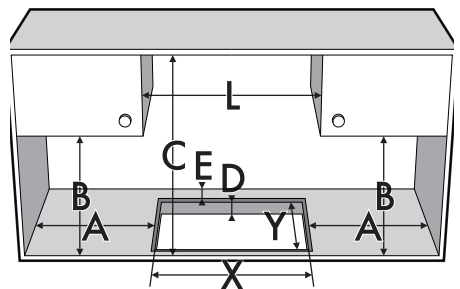

A (mm)	B (mm)	C (mm)	D (mm)	E (mm)
min 110	min 460	min 750	20 - 40	min 50

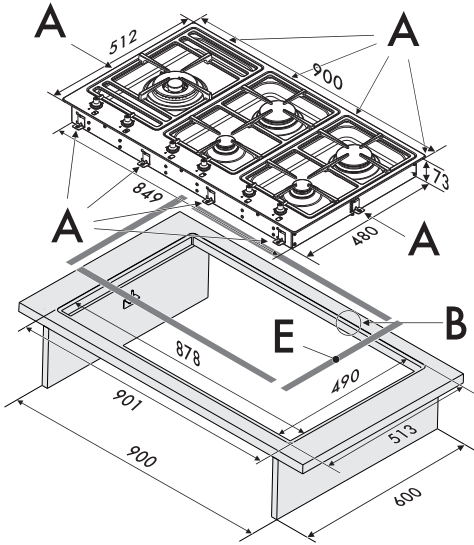

This built-in model requires a 3 mm deep section to be routed out of the worktop (detail "B" in the figure above).

Before positioning the appliance, the insulating seal provided must be placed on the routed section (E).

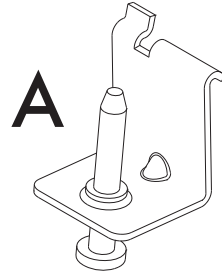
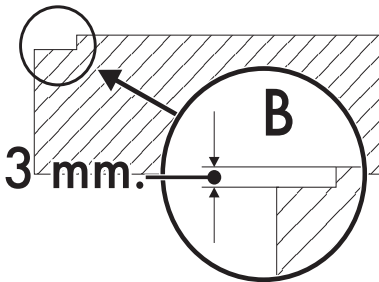

After performing these operations, fasten the appliance in place with the dedicated brackets supplied (A) in order to achieve a perfectly flush mount, per the instructions shown in the figure.

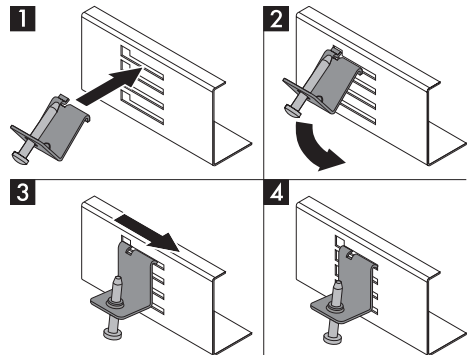

The brackets must be positioned only after placing the cooktop on the seal.



- Do not attach the cooktop with silicone sealant, as this would not allow subsequent removal without damaging the appliance.
- If using a laminate worktop, it is advisable to prime the routed groove with a suitable proprietary product to protect against water ingress.



Installation



- For fixing this product to the support structure, you are advised not to use mechanical or electrical screwdrivers and to exert moderate manual pressure on the fastening elements.
- It is advisable to use the supplied brackets in all the fixing points.

This appliance can also be installed in a **90 cm base**.

To fit the brackets the appliance must be inserted into the opening made in the counter top, with the edge resting on the actual top.

To bracket the cooktop laterally, just fix the two "L" brackets to the sides of the unit (2) using the supplied screws (4) making sure to align the slot (3) on the bracket with the rivet (1) on the bottom of the product. Stabilise the fixing of the cooktop by tightening the screw (5) in the rivet (1).

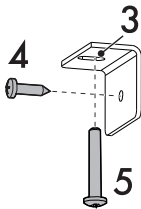
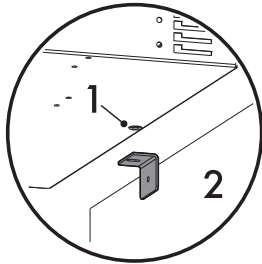

Dimensions: gas and electrical connection location (measurements in mm)

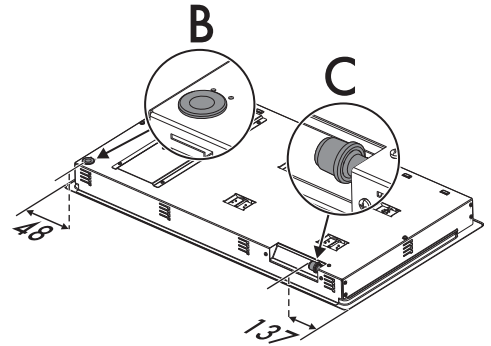

B Electrical connection

C Gas line connection

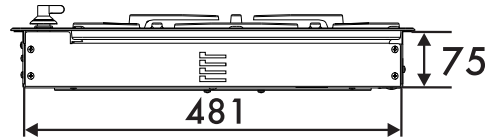

View from right



View from rear



5.4 Mounting

Over built-in oven

The distance between the cooktop and the kitchen furniture or other installed appliances must be enough to ensure sufficient ventilation and air discharge.

If installed above an oven, a space must be left between the bottom of the cooktop and the top of the appliance installed below.

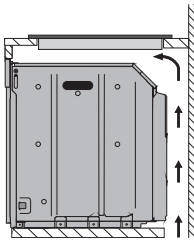

opens on bottom

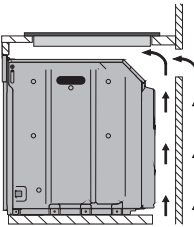

Opens on bottom and on rear



If installed on top of an oven, the oven must be equipped with a cooling fan.

Over empty kitchen unit or drawers

If there are other pieces of furniture (side walls, drawers etc.), dishwashers or fridges under the cooktop, a double-layer wooden base must be installed at least **10 mm** from the bottom of the cooktop to avoid any accidental contact. It must only be possible to remove the double-layer base using suitable equipment.

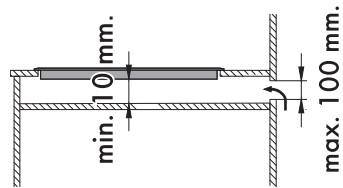
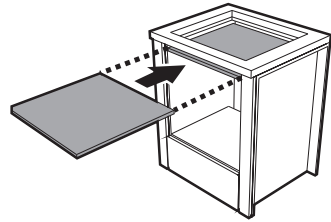

Opens on rear

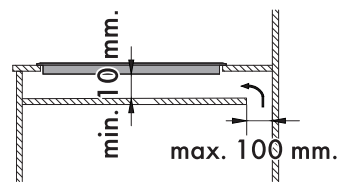

Opens on bottom



Failure to install the double-layer wooden base exposes the user to possible accidental contact with sharp or hot parts.



Installation

5.5 Gas connection



**Gas leak
Danger of explosion**

- After carrying out any operation, check that the tightening torque of gas connections is between 10 Nm and 15 Nm.
- If required, use a pressure regulator that complies with current regulations.
- At the end of the installation, check for any leaks with a soapy solution, never with a flame.
- Installation with flexible hose must be carried out so that the length of the piping does not exceed 1,2 metres when fully extended; make sure that the hoses do not come into contact with moving parts and that they are not crushed in any way.
- The hoses should not come into contact with moving parts and should not be crushed in any way.

Connection of the appliance to the gas supply must be in accordance with the requirements of AS5601. A 1/2" BSP connector at the inlet is recommended and the gas supply line to the appliance must be of adequate length to allow sufficient withdrawal of appliance for service or disconnection and be:

1. annealed copper pipe or;
2. flexible hose according to AS/NZ1869 & be at least Class "B", 10 mm diameter.

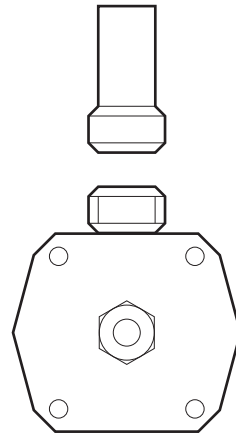

The appliance must be installed with provision to allow the gas to be turned off and disconnected for servicing and removal of the appliance as required from the gas supply. Before the appliance is operated make certain all relevant parts are placed in the correct position.

On completion of the installation, the installer **MUST** check for gas leaks and test each burner individually for the correct flame. Once all burners have been tested individually, turn all burners on together. Warranty service calls do not cover these adjustments!

General information

This appliance is suitable for installation with Natural Gas or ULPG (propane/butane). Refer to "Burner and injector characteristics tables" paragraph for the relevant burner pressure and appropriate injector sizes. When the appliance is to be connected to Natural Gas then the pressure regulator must be fitted to the gas inlet. A test point (for checking the gas pressure) is supplied either with the regulator or as a separate fitting in the case of ULPG (propane) appliances.



To check the operating pressure of the appliance it is recommended at least 2 large size burners are used. Ensure appliance is secured to wall when installation is completed.

N.G. The regulator must be fitted to the appliance inlet connection. Gas pressure must be adjusted to 1.0 kPa when approximately 50% of the burners are on high flame, the appliance test point is located on the regulator.

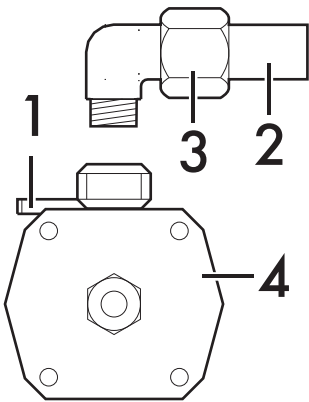

- 1 Test Point location
- 2 Gas inlet pipe
- 3 Elbow
- 4 Regulator

U.L.P.G. Gas pressure must be checked to confirm the appliance operating pressure is 2.75 kPa, the appliance test point is the Rapid burner injector as shown below.

1. Disconnect the power.
2. Light the auxiliary burner and set to high flame. Ensure all other burners are off.
3. Zero manometer, then apply flexible tubing to seal over the Rapid burner injector, hold securely in place and check the gas pressure by pressing in the corresponding burner control knob in, then turning to high flame position.
4. If the pressure is 2.75 kPa, reassemble the burner and perform the final checks as per this instruction manual.
5. If the pressure is **not** 2.75 kPa, disconnect the appliance and check/adjust/replace the LPG cylinder regulator(s) as appropriate in accordance with AS/NZS 5601.

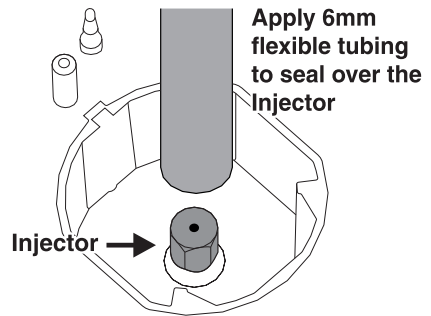

Patent 2015101170. For enquires contact Gas Approval Consulting Pty Ltd Smeg licence 033 for SAI-400046 only



Installation

Connection to LPG

Use a pressure regulator and make the connection on the gas cylinder following the guidelines set out in the regulations in force.

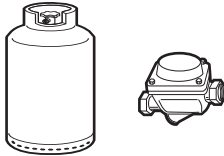

The supply pressure must comply with the values indicated in the "Gas types and Countries" table.

Room ventilation

The appliance should be installed in rooms that have a permanent air supply in accordance with the standards in force. The room where the appliance is installed must have enough air flow needed for the regular combustion of gas and the necessary air change in the room itself. The air vents, protected by grilles, must be the right size to comply with current regulations and positioned so that no part of them is obstructed, not even partially.

The room must be kept adequately ventilated in order to eliminate the heat and humidity produced by cooking: in particular, after prolonged use, you are recommended to open a window or to increase the speed of any fans.

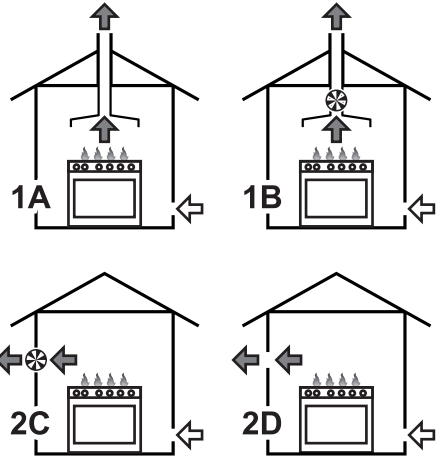

- 1 Extraction using a hood
- 2 Extraction without a hood
- A Single natural draught chimney
- B Single chimney with extractor fan
- C Directly outdoors with wall- or window-mounted extractor fan
- D Directly outdoors through wall

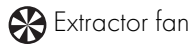

Extraction of the combustion products

The combustion products may be extracted by means of hoods connected to a natural draught chimney whose efficiency is certain or via forced extraction. An efficient extraction system requires precision planning by a specialist qualified in this area and must comply with the positions and distances indicated by the applicable standards.

When the job is complete, the installer must issue a certificate of conformity.



5.6 Adaptation to different types of gas

In case of operation with other types of gas, the burner injectors must be changed and the minimum flame adjusted on the gas taps.

Changing the injectors

1. Remove the trivets from the cooktop.

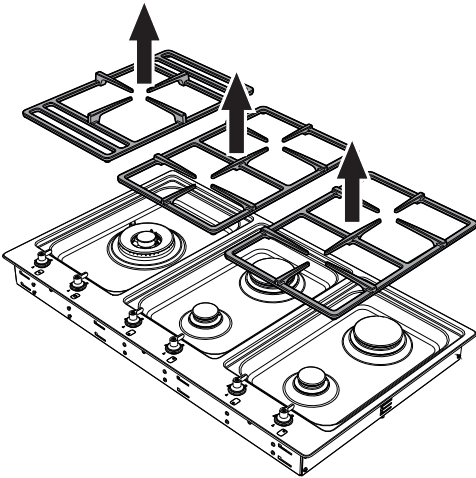

2. Remove the flame-spreader crowns and relative burner caps.

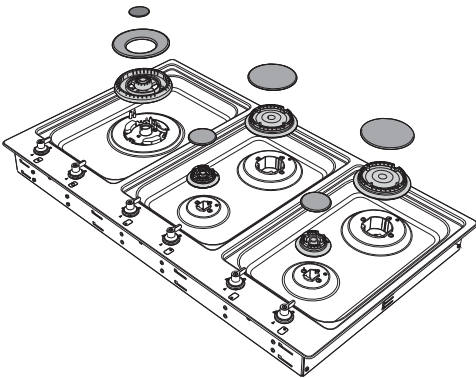

3. Use a 7 mm socket wrench to unscrew the burner injectors, then replace them with a new injector suitable for the type of gas to be used (see "Burner and injector characteristics table").

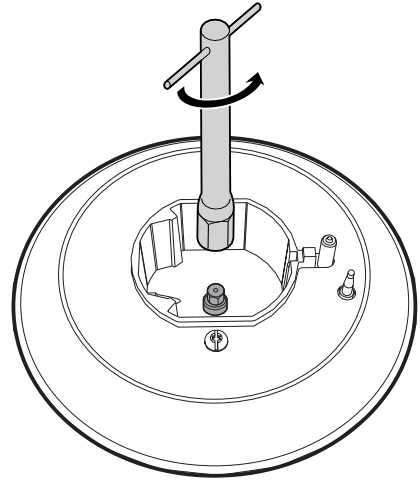

4. Replace the burners in the correct position.



The injector tightening torque must be no more than 3 Nm.



Installation

Adjusting the minimum setting for natural or city gas

1. Light the burner and turn it to the minimum position.
2. Remove the knobs by pulling them upwards.

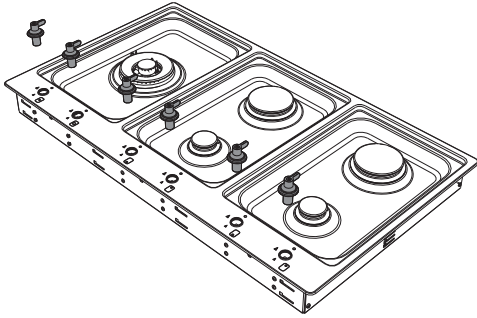

3. Turn the regulating screw on the side of the valve spindle until a steady minimum flame is achieved.

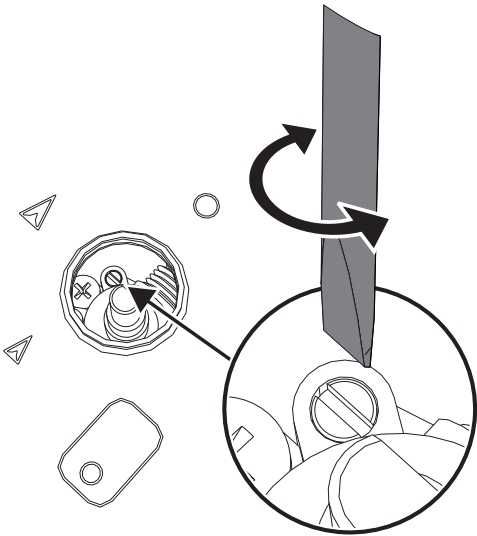

4. Refit the knob and verify that the burner flame is stable.

5. Turn the knob rapidly from the maximum to the minimum setting: the flame should not go out. Repeat the operation on all gas valves

Adjusting the minimum setting for LPG

Tighten the screw located at the side of the valve spindle clockwise all the way.



Following adjustment to a gas other than the one originally set in the factory, replace the gas setting label fixed to the appliance with the one corresponding to the new gas. The label is inserted inside the injector pack (where present).

Lubricating the gas valves

Over time, the gas valves may become difficult to turn and become seized. Clean them internally and replace the lubrication grease.



Lubrication of the gas valves should be performed by authorised persons.



Burner and injector characteristics tables

NG 1.0 kPa	AUX	RR	UR2 Int.	UR2 Ext.
Nominal gas consumption (MJ/h)	3.9	9.6	18.3	
Injector (1/100 mm)	90	140	90	175
ULPG 2.75 kPa	AUX	RR	UR2 Int.	UR2 Ext.
Nominal gas consumption (MJ/h)	3.9	9.6	16.8	
Injector (1/100 mm)	54	85	50	100

5.7 Electrical connection



Power voltage Danger of electrocution

- Have the electrical connection performed by authorised persons.
- Use personal protective equipment.
- The appliance must be connected to earth in compliance with electrical system safety standards.
- Disconnect the mains power supply.
- Do not pull the cable to remove the plug.
- Use cables withstanding a temperature of at least 90°C.
- The tightening torque of the screws of the terminal supply wires must be 1.5 - 2 Nm.

General information

Check the grid characteristics against the data indicated on the plate.

The identification plate bearing the technical data, serial number and brand name is visibly positioned on the appliance.

Do not remove this plate for any reason.

Perform the ground connection using a wire that is 20 mm longer than the other wires.



Pass the power supply cable through the back of the unit, taking care that it does not touch the bottom casing of the cooktop or the oven (if any) installed underneath it.



Installation

The appliance can work in the following modes:

- 220-240 V 1N~

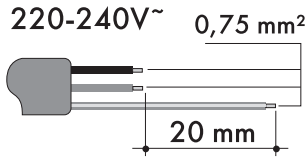

Use a **3 x 0.75 mm² three-core** cable.

i The values indicated above refer to the cross-section of the internal conductor.

Fixed connection

Fit the power line with an omnipolar circuit breaker, with contact separation of at least 3 mm, in compliance with installation regulations.

The circuit breaker should be located near the appliance and in an easily reachable position.

Connection with plug and socket

Make sure that the plug and socket are of the same type.

Avoid using adapters, gang sockets or extensions as these could cause overheating and a risk of burns.

Testing

At the end of installation, carry out a brief inspection test. If the cooktop fails to operate, after checking that you have carried out the instructions correctly, disconnect the appliance from the power supply and contact Technical Support.

5.8 Instructions for the installer

- The plug must be accessible after installation. Do not bend or trap the electrical power cable.
- The appliance must be installed according to the installation diagrams.
- Do not try to unscrew or force the threaded elbow of the fitting. You may damage this part of the appliance, which may void the manufacturer's warranty.
- Use soap and water to check for gas leaks on all connections. **DO NOT** use naked flames when looking for leaks.
- Turn on all the burners separately and at then all together to make sure that the gas valve, burner and ignition are working properly.
- Turn the burner knobs to the minimum position and check that the flame is stable for each individual burner and all the burners together.
- If the appliance does not work correctly after having carried out all the checks, contact your local Authorised Service Centre.
- Once the appliance has been installed, please explain to the user how to use it correctly.



9 14777722 / C