

Security Units

ASSEMBLY INSTRUCTIONS

CAUTION

INSPECT CONTENTS IMMEDIATELY AND FILE CLAIM WITH DELIVERING CARRIER FOR ANY DAMAGE. **SAVE YOUR BOX AND ALL PACKING MATERIALS.** YOU ARE RESPONSIBLE FOR DAMAGE TO YOUR UNIT IF RETURNED IMPROPERLY PACKED.

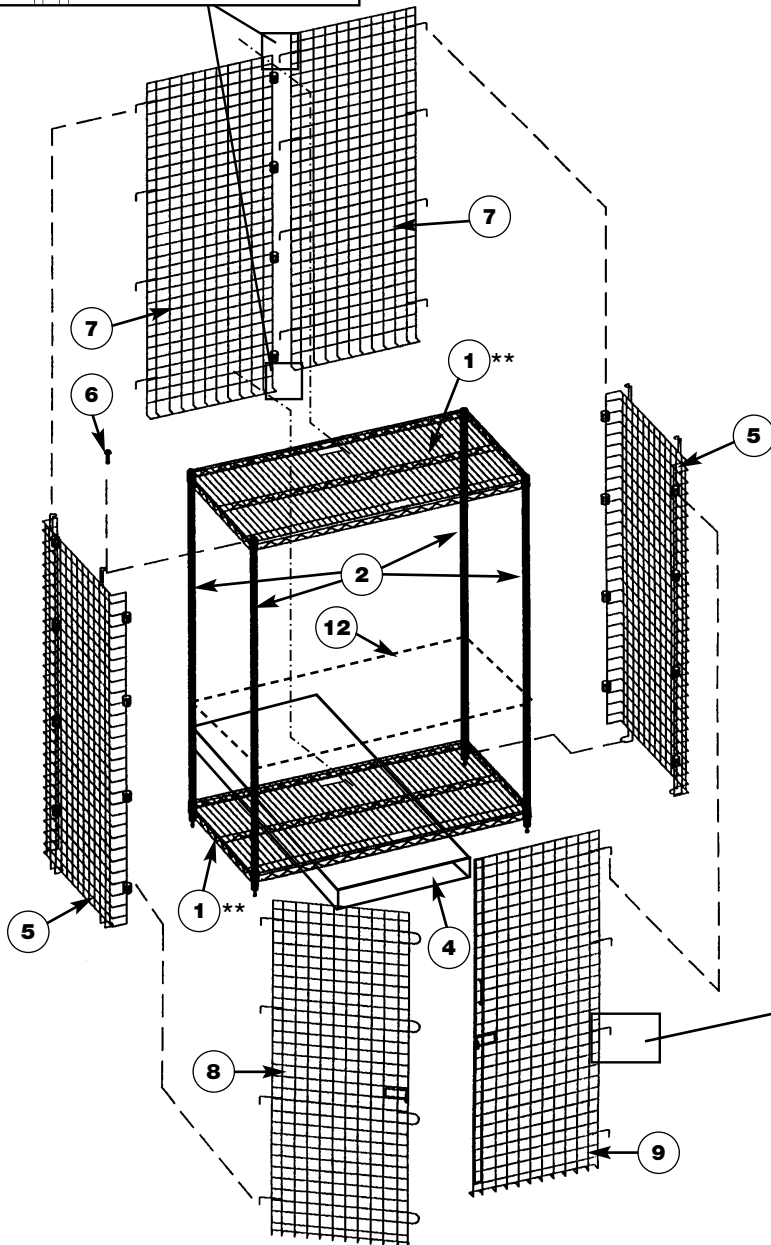
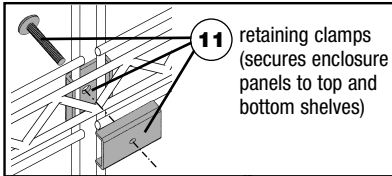

Parts List

#	qty	description
#1	2	Notched Wire Shelf **
#2	4	Posts
#3	2	(bags of four) Aluminum Split Sleeves with Retaining Rings
#4	1	Spacer Box
#5	2	End Panels
#6	4	1/4" - 16" x 1 1/4" Tamper Proof Bolts
#7	1	Back Panel (48" & 60" units come in two pieces)
#8	1	Left Door Panel
#9	1	Right Door Panel with Latch
#10	8	Bushings
#11	*	Retaining clamps (#A221681)
#12	*	Optional Center Shelves, if ordered.

* Varies per order.

**** IMPORTANT TO NOTE IF YOUR UNIT CAME WITH OPTIONAL CENTER SHELVES**

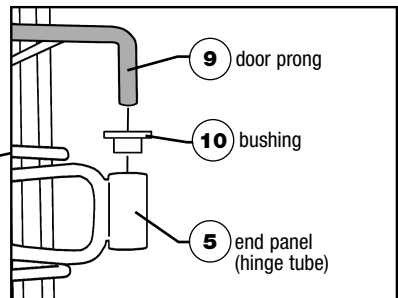
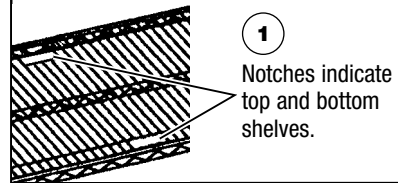

(continued on next page)

EG9837 Revised 04/24



• 100 Industrial Boulevard, Clayton, Delaware 19938-8903 U.S.A.
• Phone: 302/653-3000 • 800/441-8440 • Fax: 302/653-2065
• www.eaglegrp.com • www.eaglehmc.com

Eagle Foodservice Equipment, Eagle MHC, and SpecFAB® are divisions of Eagle Group. ©2024 by the Eagle Group

Security Units

ASSEMBLY INSTRUCTIONS

Step 1: Assemble shelves and posts, starting with bottom shelf.

NOTE: Bottom shelf must be assembled to posts **FIRST**.

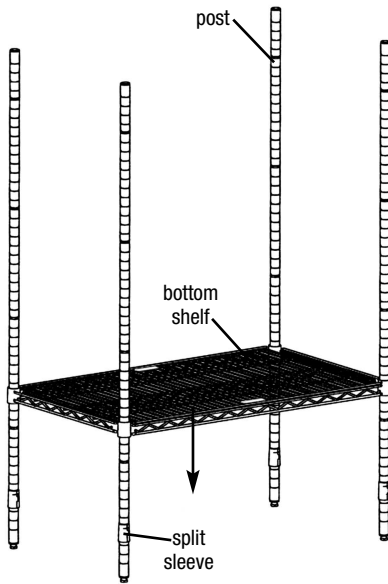

ATTACH SPLIT SLEEVES TO POSTS.

- Wider part of taper goes toward the bottom.
- Make sure rib on split sleeve is seated into groove on post.
- Set aside retaining rings until later.

MOUNT BOTTOM SHELF.

- Insert top of posts through bottom of shelf corner collars.
 - Slide shelf down posts until split sleeves are seated inside corner collars.
- DO NOT SECURE YET!**

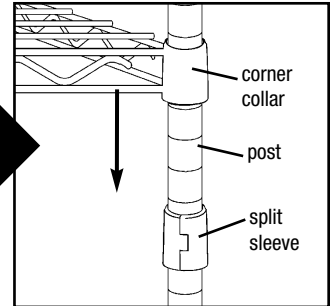
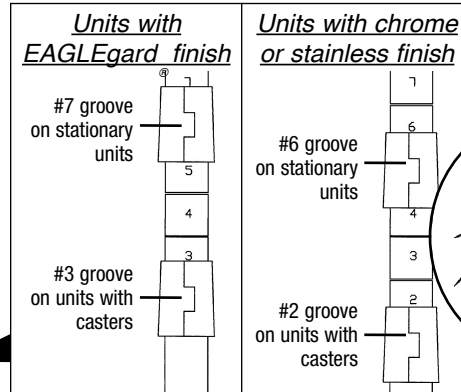

IMPORTANT: IF YOU HAVE OPTIONAL CENTER SHELVES, THEY MUST BE INSTALLED **IMMEDIATELY** AFTER INSTALLING BOTTOM SHELF. REPEAT **STEP 1** TO MOUNT OPTIONAL CENTER SHELVES (IF ANY), WORKING FROM BOTTOM TO TOP.

REPEAT **STEP 1** TO MOUNT TOP SHELF.

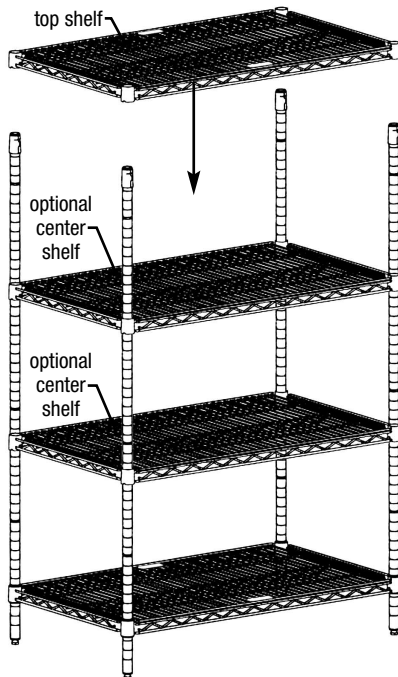

Step 2: Secure center shelves (if any) and top shelf.

DO NOT SECURE BOTTOM SHELF YET.

PLACE A BOARD ACROSS SHELF CORNER AND GENTLY TAP WITH HAMMER OR MALLET.

- Do NOT hammer directly on wire or corner.

APPLY SPLIT SLEEVE RETAINING RINGS.

- Make sure the groove, located on top of split sleeve, is accessible.
- Gently tap ring into the groove of each split sleeve.

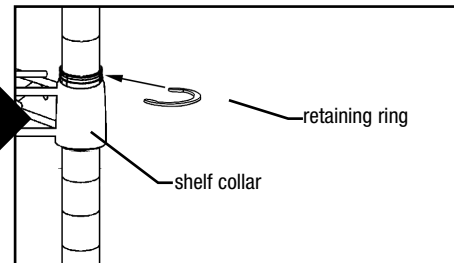
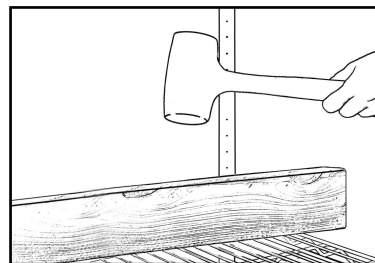

(continued on next page)

Security Units

ASSEMBLY INSTRUCTIONS

Step 3: Attach end panels.

NOTE*: Additional standard shelves cannot be added once the end panels are in place.

* Add-A-Shelf® and Quad-Adjust® shelves can be added after assembly. Contact Eagle Group for more information.

TEMPORARILY RAISE BOTTOM SHELF.

- Place assembled shelf unit over spacer box (same box the shelves were packed in).
- Lift bottom shelf off split sleeves, so shelf rests on spacer box and posts touch the floor.

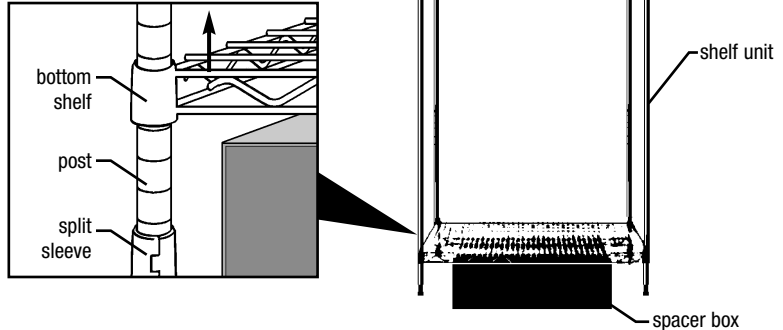

ATTACH END PANELS TO UNIT.

- Place end panels in position.
Note: Large loops should be at the bottom, small loops at the top.
- Tip unit slightly so bottom loops of end panel can slide under bottom of front and rear posts.
- Lift enclosure panel and position top loops over top of front and rear posts.
- Secure end panel in place, using "one-way" bolts.

Note: For stainless steel units, use provided tamper-resistant #14 spanner insert bit to install bolts.
IMPORTANT: If using drill to assemble, USE DRILL AT LOW POWER SETTING.

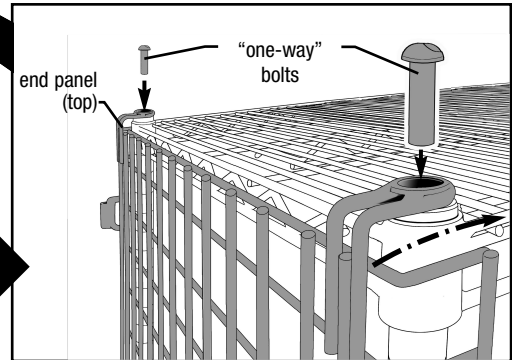
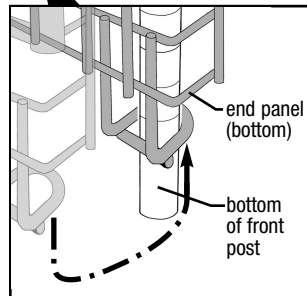
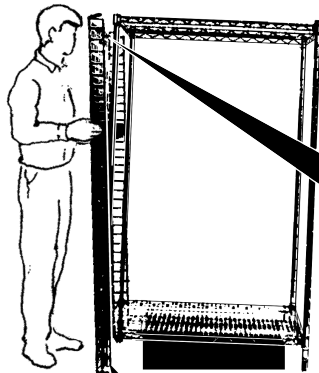

REPEAT **STEP 3** TO ATTACH REMAINING END PANEL.

Step 4: Attach rear panel(s).

- Place rear panel(s) in position. Insert rear panel prongs into end panel hinge tubes as shown below.
Note: 36" units have one panel, 48" and 60" have two panels.

- Use the retaining clamps to secure back panel(s) to top shelf (**do NOT secure bottom shelf yet**).

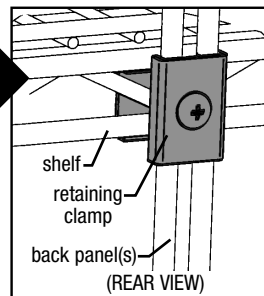
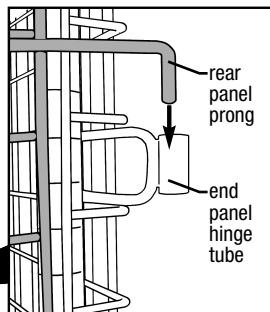
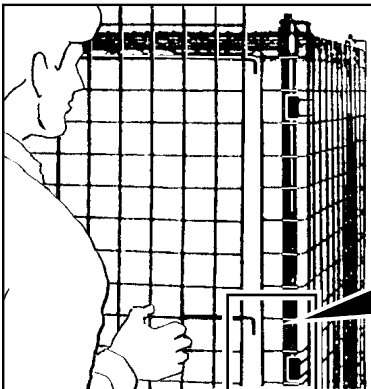

(continued on back page)

Security Units

ASSEMBLY INSTRUCTIONS

Step 5: Secure bottom shelf.

- Remove spacer box and lower bottom shelf onto split sleeves.

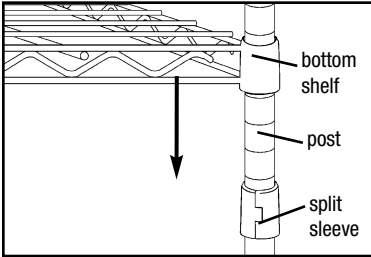

- Place a board across each corner and tap with hammer or mallet.

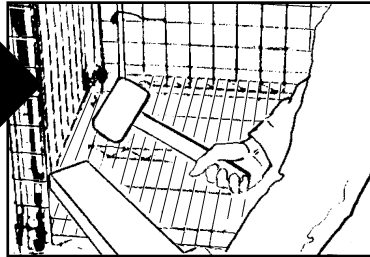

- Gently tap split sleeve retaining ring into groove of each split sleeve.

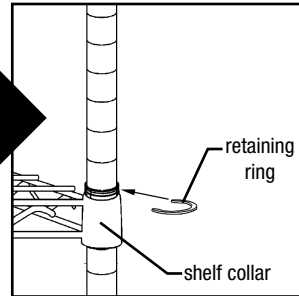

FOR SIDE-TO-SIDE LENGTHS MORE THAN 36":

- Secure back panel(s) to bottom shelf using retaining clamps.

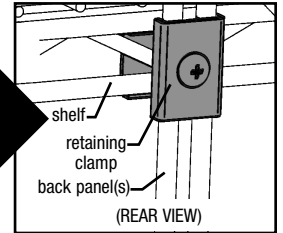

IF YOUR UNIT IS STATIONARY AND DOES NOT HAVE CASTERS OR DOLLY TRUCK, SKIP **STEP 6** AND PROCEED TO **STEP 7**.

Step 6: Attach casters or dolly truck to unit.

IF YOUR UNIT HAS CASTERS:

- Gently lay unit on its side.
- Insert caster stem into bottom of each post, and tap with mallet. This may require several taps.
- Stand unit upright onto casters.

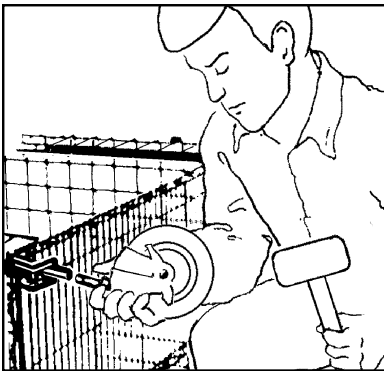

IF YOUR UNIT HAS A DOLLY TRUCK:

- Stand unit onto dolly truck.
- From underside of dolly truck, run bolts (provided) through dolly truck and fasten into bottom of posts.

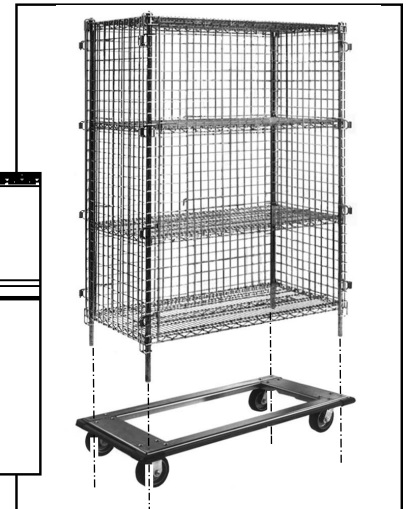
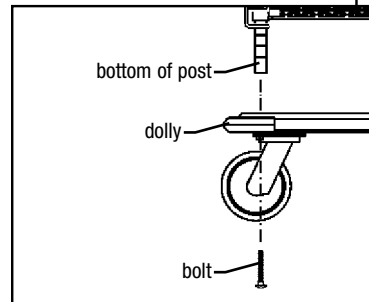

Step 7: Attach door panels.

- Note: Insert bushings (provided) into hinge tubes of end panels BEFORE installing doors.*
- Hang left door panel and right door panel.

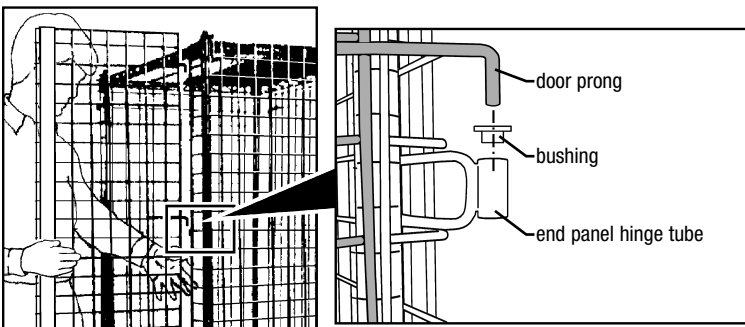

TO CLOSE DOORS:

- Push left-hand door shut.
- Right-hand door features movable latch. Move latch upward, push door shut, then move latch downward. Latch hooks into top and bottom shelves, keeping both doors closed.

(End)

EAGLE GROUP
Profit from the Eagle Advantage®

- 100 Industrial Boulevard, Clayton, Delaware 19938-8903 U.S.A.
- Phone: 302/653-3000 • 800/441-8440 • Fax: 302/653-2065
- www.eaglegrp.com • www.eaglehmc.com

Eagle Foodservice Equipment, Eagle MHC, and SpecFAB® are divisions of Eagle Group. ©2024 by the Eagle Group