

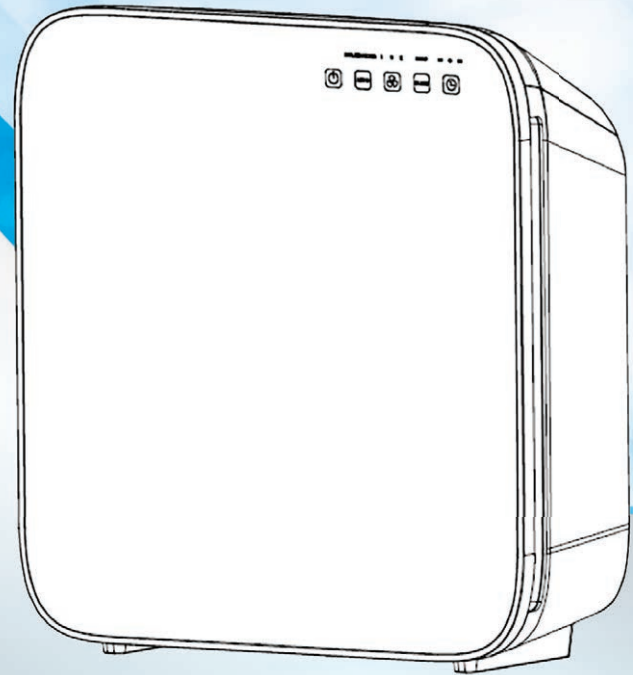

Air Purification System



Congratulations on your purchase of a Cli~Mate Air Purification System

This Air Purifier improves the quality of the air in your home by helping to eliminate airborne matter such as allergens and unpleasant odours.

Note: Please read through the instructions carefully before using or installing the product and ensure that the manual is kept in a safe place for future reference.

The system must be properly installed and located in accordance with the installation instructions before it is used.

During the set up of this product if you have any questions / comments / issues DO NOT RETURN TO STORE. FOR SERVICE AND TECHNICAL ADVICE ON THIS PRODUCT, FREE CALL 1300 764 325.

CUSTOMER HOTLINE: 1300 764 325

Register your warranty online at
www.cli-mate.com.au/warranty-and-registration

Aquaport Corporation Pty Ltd
70 Hardys Road, Torrensville SA 5031

Telephone: 08 8354 0711

Facsimile: 08 8354 0722

Email: aquaport@aquaport.com.au

Web: www.cli-mate.com.au

Social: [f/climatebrand](https://www.facebook.com/climatebrand) [t@climatebrand](https://twitter.com/climatebrand)

New Zealand Customers

Telephone: 0800 210 190

Email: info@aquaport.co.nz



Electrical Requirements:
Australia / New Zealand 220-240V 50/60Hz
Due to manufacturing alterations product may vary slightly from the pictured.

SAFETY PRECAUTIONS

Read all instructions carefully.

- All components need to be installed in accordance with the user manual instructions for correct performance of unit.
- This appliance should be used in conjunction with a safety switch.
- This appliance is not intended for use by persons (including children) with reduced physical, sensory or mental capabilities, or lack of experience and knowledge, unless they have been given supervision or instruction concerning use of the appliance by a person responsible for their safety.
- Do not operate any appliance with a damaged cord or plug or after the appliance malfunctions, or has been damaged in any manner.
- If the supply cord is damaged, it must be replaced by the manufacturer, its service agent or similarly qualified persons in order to avoid a hazard.
- Children should be supervised to ensure that they do not play with the appliance.
- Do not use appliance for other than intended use.
- Do not disassemble, repair or re-form the unit, it may cause injury, fire or other malfunctions. A qualified service agent must make all service adjustments. Removing any part or attempting to service the unit will void the warranty.
- Unplug from outlet when not in use and before cleaning. Never plug in or unplug unit with wet hands.
- Do not use unit outdoors or expose to greasy or damp environments.
- Keep the air inlet and outlet free from air blocking materials such as clothing, plastic bags or papers. Air flow is required for the unit to operate effectively.
- Place unit on a flat location at least 30cm from wall or other appliances.
- When the unit is in operation, keep all body parts, jewellery, hair and loose clothing away from the openings.
- Unit must be placed on a stable flat surface to reduce possible excessive vibration and noise.
- Keep the unit away from fire, flammable gas, combustible products or vapours, and corrosive substances.
- Do not operate the unit without filters.
- When transporting the air purifier, always hold the handle at the back of the unit.
- Do not remove the front cover of the unit when it is in operation.
- To protect against fire, electric shock and personal injury, do not immerse cord, plugs, or appliance in water or other liquid.
- Do not place on or near a hot gas, electric burner or heating appliance.
- Check voltage to be sure that the voltage indicated on the nameplate agrees with your voltage.

PRODUCT FEATURES

Filter

The 3 layer filter contains a Pre-filter, a HEPA filter and an activated carbon filter.

- The Pre-filter traps larger particles such as dust, pet hair and large-sized allergens.
- The HEPA filter (Grade H12) removes 99.5% of particles as small as 0.3 microns and greater from the air. It is capable of removing smoke, dust, pollen, pet dander, mold spores, bacteria and allergens in the air.
- The Activated carbon filter absorbs common household odours, VOCs, cigarette odours, chemical fumes and smoke.

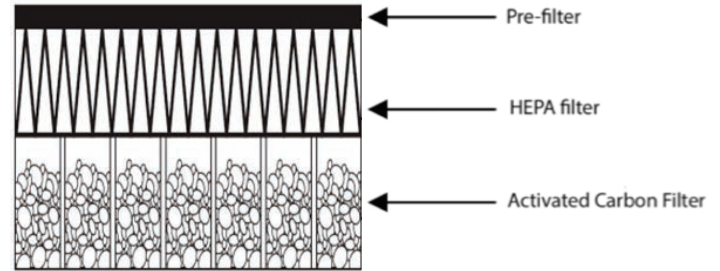

COMPONENT IDENTIFICATION

1. Front Cover
2. Control buttons
3. Air Outlet
4. Pre-filter, HEPA and active carbon filter
5. Dust and odour sensor

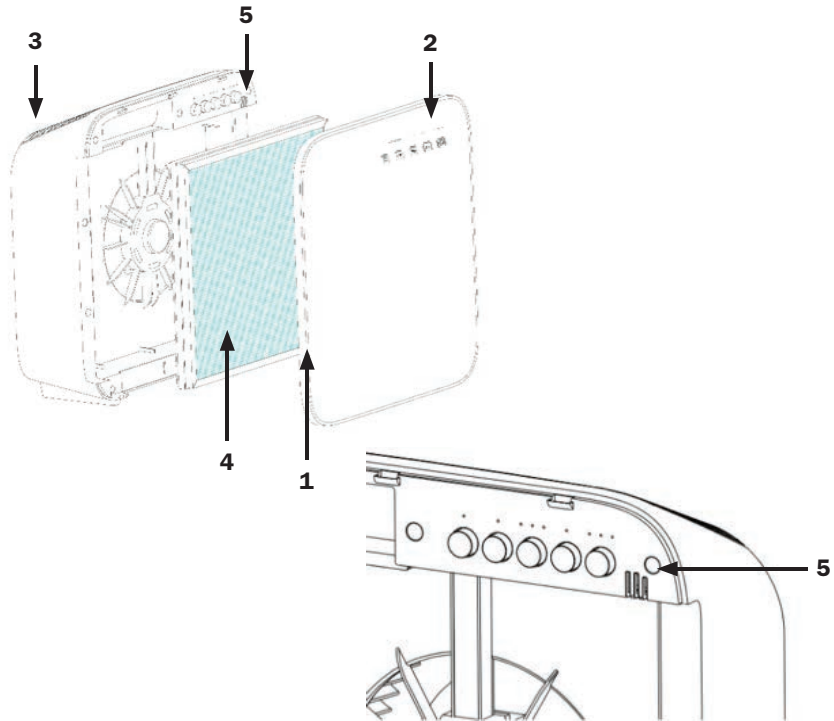

CONTROL PANEL/BUTTONS

1. “POWER” BUTTON:

Turns unit on or off.

2. “AUTO” Mode:

In this mode, the speed of the air flow/fan speed will change automatically depending on the air quality as detected by the dust and odour sensor.

NOTE: The AUTO button is also used to reset the filter timer. Press and hold button for 5 seconds to reset filter timer.

3. “SPEED” Options:

Allows selection for desired speed setting – low (I), medium (II), high (III).

4. “SLEEP” Mode:

In this mode, the unit will continue to operate, but with the display lights dimmed.

5. “TIMER”:

To set automatic OFF timer at 2, 4, 8 hour settings.

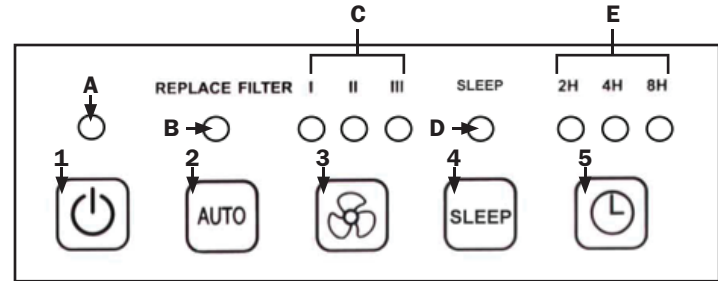

DISPLAY PANEL

A. Power Icon light illuminates when unit is on.

B. Auto Icon light illuminates when in AUTO mode.

NOTE: When the Auto icon light flashes, it indicates that the Filter will need to be replaced.

C. Fan Speed Indicator Icon light illuminates on selected setting.

I - Low speed

II - Medium speed

III- High speed

D. Sleep Icon light illuminates when in sleep mode.

E. Timer Indicator Icon light illuminates on selected setting.

2H – 2 hours

4H – 4 hours



8H – 8 hours



PRODUCT SPECIFICATIONS

	Air Purifier
Model Code	CLI-AP35
Dimensions (mm)	390 (L) x 145(W) x 428(H) mm
Coverage area	up to 30m ²
Power consumption	50 watts
Net weight	4.5 kgs
Clean air delivery rate	≥145 cfm
Noise level at High speed	<50dB
Noise level at Low speed	<30dB
Replacement filter	CLI-AP35-RF

OPERATION INSTRUCTIONS

Important: Before first use, open the front cover and unwrap the filter before operation. See page 6 for filter details.

1. Plug the unit into a power socket. Ensure unit is located on a flat, stable and level surface.
2. Press the POWER button  to turn the unit on. The unit will start running and the display panel icon lights will illuminate indicating the current settings.
3. To select AUTO mode, press the  button. The AUTO icon light will illuminate and the fan speed of the unit will change automatically depending on the air quality as detected by the dust and odour sensor.

4. To select the fan SPEED, press the  button until the light icon illuminates on the desired speed - low (I), medium (II), high (III).
5. To select SLEEP mode, press the  button. The SLEEP icon light will illuminate and all illuminated icon lights will dim. Unit will remain in operation at the current selected settings.
6. To set automatic off TIMER press the  button until the light icon illuminates on the desired time 2/4/8 hours. The unit will automatically switch off when the duration has lapsed.

During the setup of this product, if you have any questions/ comments / issues, DO NOT RETURN TO STORE.

FOR SERVICE AND TECHNICAL ADVICE ON THIS PRODUCT FREE CALL 1300 764 325.

CLEANING AND MAINTENANCE

Before carrying out any maintenance or cleaning of the unit, make sure that the power to the unit is turned off and power cord is unplugged from the power socket.

External cleaning of the unit:

- Do not clean the unit with any abrasives cleaning agents or solvents.
- Do not apply any water directly onto the unit of cleaning.
- Only use a soft clean cloth for all cleaning purposes.
- Clean the air outlet with a dry cloth, soft brush or vacuum cleaner.

CLEANING THE PRE-FILTER, HEPA AND ACTIVATED CARBON FILTER

It is recommended that the Pre-filter (the removable black layer) is cleaned every 1-2 weeks of operation, depending on the air quality of the room.

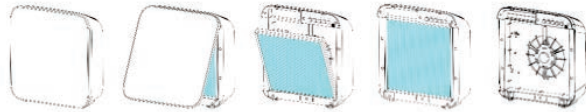

To clean filters:

1. Turn the unit off and disconnect the power.
2. **OPEN THE FRONT COVER:** Place both hands at the bottom corners of the front cover and pull out.
3. **REMOVE THE FILTER:** Pull out the filter by the belt attachment.
4. Gently peel away the Pre-filter (black layer), which is attached by Velcro.
5. Run a vacuum cleaner with a nozzle or brush attachment on low power setting along the HEPA (white side), Activated Carbon (black side), and both sides of the Pre-filter to pick up the dust and various particles.
6. Re-attach the Pre-filter layer and place the filter back into the air purifier.

Note: When placing the filter back into the air purifier, ensure that the filter belts and Pre-filter is facing outwards.

7. Reattach the front cover.

REPLACING THE FILTER

When the lifespan of the 3-layer filter reaches its end, the icon light located under the “REPLACE FILTER” will flash, indicating that it needs to be changed. Discard the old filter and replace with a new one. It is not reusable.

The lifespan and duration of the filter depends on the air quality and surrounding environment. The higher the level of pollutants, the shorter the filter lifespan. It is advisable to change the filter at least every 6 months of unit operation.

CLI-Mate Replacement Filter Product Code: CLI-AP35-RF

HOW TO REPLACE THE FILTER

1. Turn the unit off and disconnect the power.
2. **OPEN THE FRONT COVER:** Place both hands at the bottom corners of the front cover and pull out.
3. **REMOVE THE FILTER:** Pull out the filter by the belt attachment and discard.
4. **INSTALL NEW FILTER:** Replace with the new filter. Ensure that the filter belts and Pre-filter is facing outwards.
5. Reattach the front cover.
6. Hold down the AUTO  button for 5 seconds to reset the filter timer.

TROUBLE SHOOTING

BEFORE YOU CALL FOR SERVICE PLEASE REVIEW THE TROUBLE SHOOTING TIPS FIRST.

Problem	Possible Causes	What To Do
No Power	<ol style="list-style-type: none">1. Unit is not plugged into a wall socket.2. Front cover is not latched firmly in place.3. The filter has not been installed firmly in place.	<ol style="list-style-type: none">1. Check the connection to wall socket.2. Remove and reinstall front cover.3. Remove and reinstall the filter.
Unit overheating	<ol style="list-style-type: none">1. Air ventilation around unit not sufficient.2. Air inlet or air outlet is being obstructed or blocked by foreign objects.3. Internal malfunction.	<ol style="list-style-type: none">1. There must be at least 30cm between unit and wall or other appliances.2. Ensure there are no object obstructing the air inlet or air outlet.3. Return unit to service agent. Call customer care.
The unit is not effective	<ol style="list-style-type: none">1. Filters may be heavily soiled and due for replacement.	<ol style="list-style-type: none">1. Replace filter.

Problem	Possible Causes	What To Do
Odour coming from the air outlet	<ol style="list-style-type: none"> 1. Filter may be heavily soiled and due for replacement. 	<ol style="list-style-type: none"> 1. Replace filter.
Excessive/loud noise	<ol style="list-style-type: none"> 1. Unit is on an uneven surface. 2. Foreign objects have fallen into the unit. 3. Faulty internals. 	<ol style="list-style-type: none"> 1. Ensure the unit is placed on a level surface. 2. Ensure that no foreign objects have fallen into the unit via the air outlet. 3. Call customer care.

Customer Care: 1300 764 325

Your Aquaport Australian 1 Year Repair or Replacement Warranty

Aquaport warrants this appliance to the first purchaser and subject to the stated conditions:

Warranty covers any defects in material or workmanship in the manufactured product within the first twelve months from the date of purchase.

To make a warranty claim you must call Aquaport on toll free number 1300 764 325 for instructions. If a product is found to be faulty there is a 90 day return policy from the date of purchase.

For warranty claims outside of 90 days from date of purchase, product will be repaired or replaced at our discretion. Repair or replacement costs of the product will be covered under warranty by Aquaport.

Goods presented for repair may be replaced by refurbished goods of the same type rather than being repaired. Refurbished parts may be used to repair the goods.

Warranty does not cover filters which are consumable unless proven to have defects in material or workmanship in the manufactured product.

The benefits given to you by this warranty are in addition to other rights and remedies of the consumer law in relation to the goods or services to which this warranty relates.

Our goods come with guarantees that cannot be excluded under the Australian Consumer Law. You are entitled to a replacement or refund for a major failure and compensation for any other reasonably foreseeable loss or damage. You are also entitled to have the goods repaired or replaced if goods fail to be of acceptable quality and the failure does not amount to a major failure.

Conditions of this Warranty:

1. This product has been fully installed in accordance with the user manual installation instructions.
2. The warranty extends only to repairing or replacing any component that proves to be defective in material or workmanship.
3. The warranty does not cover defects occasioned by misuse, alterations, accidents, or used for other than the intended purpose.
4. The warranty does not cover damage to the product caused by accident, fire, or floods, power surges or black outs
5. Proof of purchase is required for warranty claims.

Please keep purchase receipt in a safe place.

To enable us to register your warranty and provide service should a problem occur, we recommend you register your warranty online at:

www.cli-mate.com.au/warranty-and-registration

Aquaport Corporation Pty Ltd

70 Hardys Road, Torrensville
South Australia 5031

Customer Care 1300 764 325

New Zealand Customers
Telephone: 0800 210 190
Email: info@aquaport.co.nz



CUSTOMER HOTLINE: 1300 764 325

Aquaport Corporation Pty Ltd
70 Hardys Road, Torrensville SA 5031

Telephone: 08 8354 0711

Facsimile: 08 8354 0722

Email: aquaport@aquaport.com.au

New Zealand Customers

Telephone: 0800 210 190

Email: info@aquaport.co.nz

Web: www.cli-mate.com.au

Social: [f](https://www.facebook.com/climatebrand)/climatebrand [t](https://www.twitter.com/climatebrand)@climatebrand