

SENCOR[®]

SAC MT9014C



MOBILE AIR CONDITIONER WI-FI

Translation of the original manual



SENCOR®

SAC MT9014C

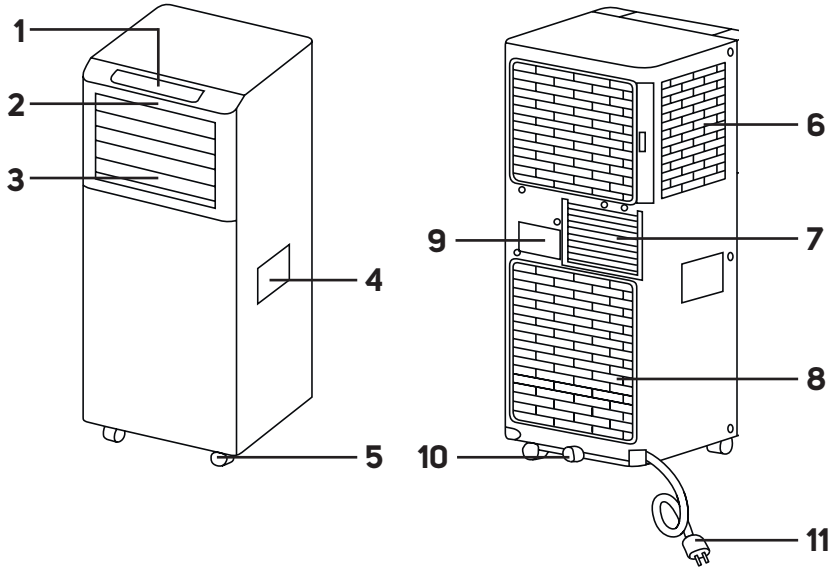
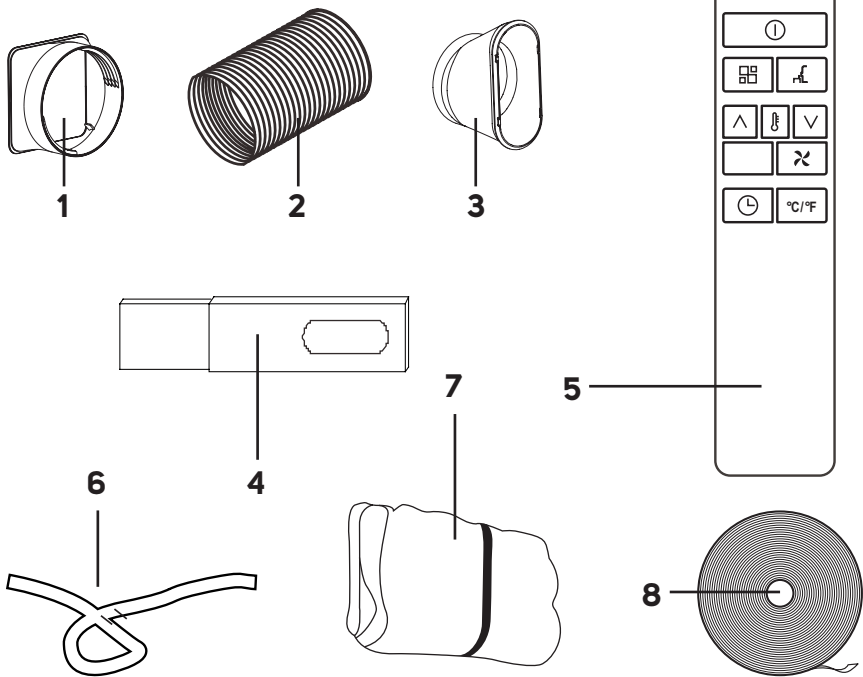

A**B**

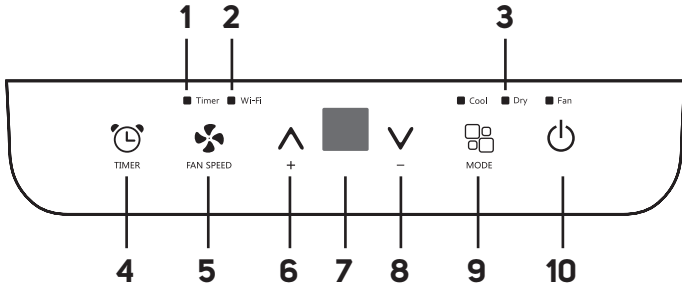
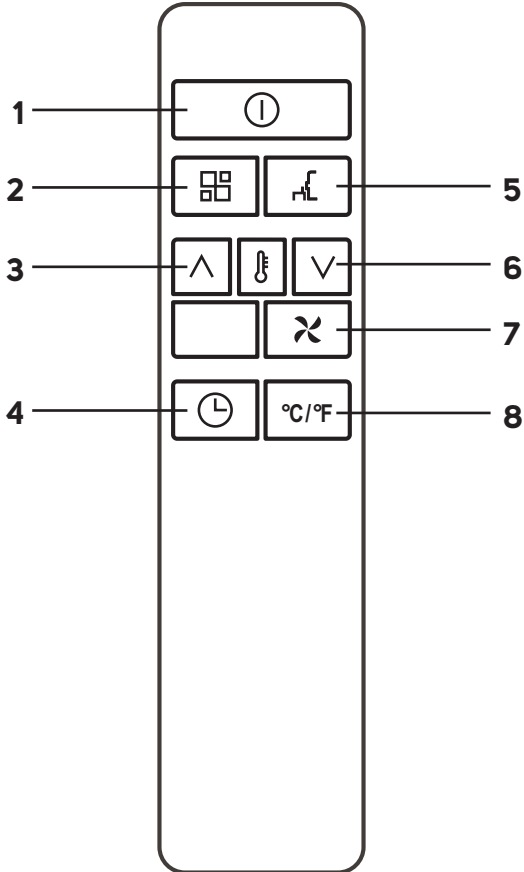
C**D**

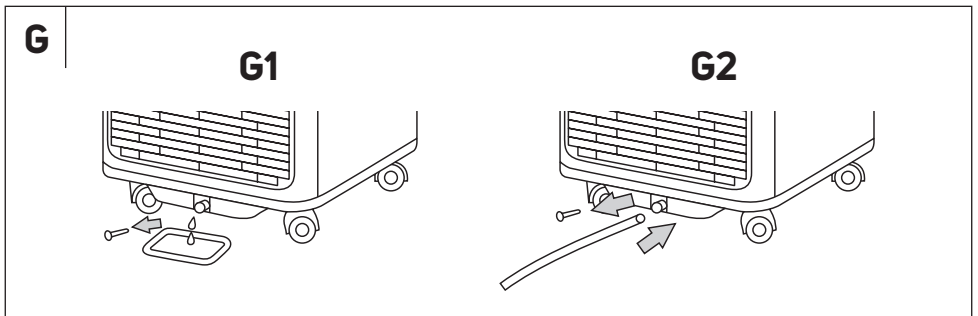
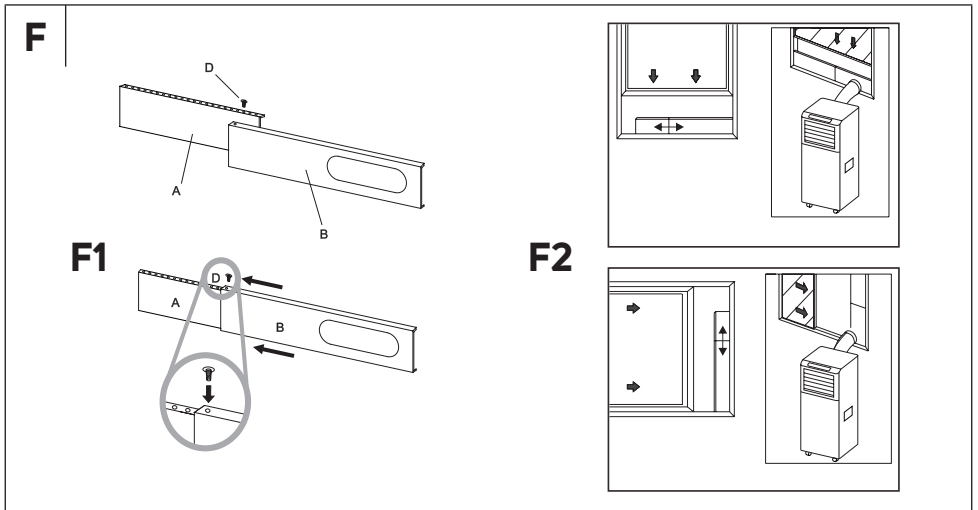
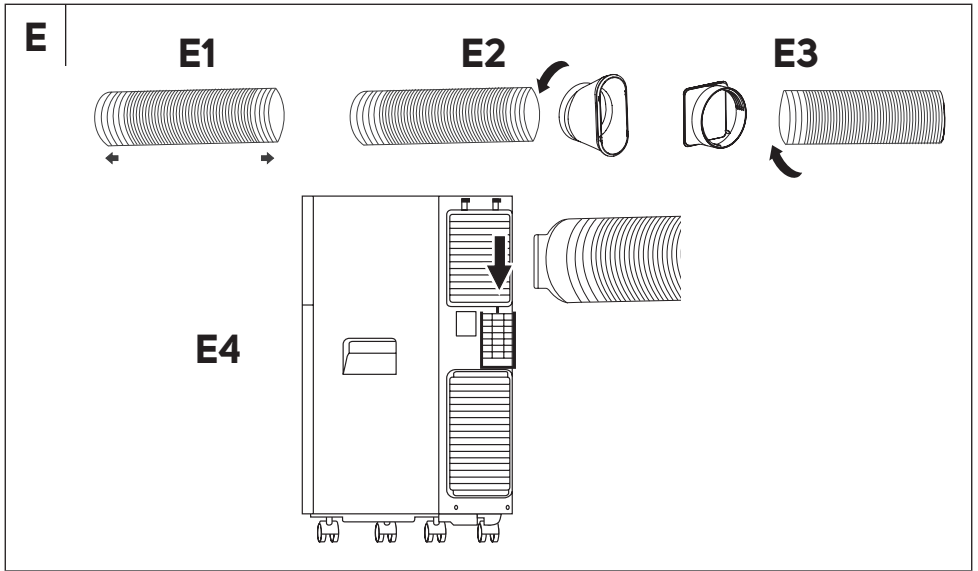

H

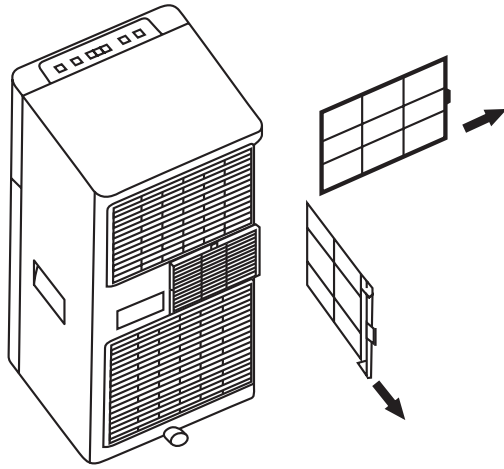

EN Mobile air conditioner Wi-Fi

Important safety instructions

READ CAREFULLY AND STORE FOR FUTURE USE.



This symbol indicates that not adhering to instructions may result in death or serious injuries.



WARNING:

To prevent the death or injury of the user or other persons or damage to property, the following instructions must be adhered to. Incorrect use as a result of not adhering to instructions may cause death, injuries or damage.

- This appliance may be used by children 8 years of age and older and by persons with physical or mental impairments or by inexperienced persons, if they are properly supervised or have been informed about how to use the product in a safe manner and understand the potential dangers. Cleaning and maintenance performed by the user must not be performed by unsupervised children. Children must not play with the appliance.
- If the power cord is damaged, it must be replaced by an authorised service centre or by another similarly qualified person, this will prevent the creation of a dangerous situation. It is forbidden to use the appliance if it has a damaged power cord.
- The appliance must be stored in a manner that prevents its mechanical damage.

- The appliance must be stored in a well-ventilated location, where the dimensions of the room correspond to the dimensions specified for its operation.
- The appliance must be stored in a room where an open flame is not continuously in use (e.g. running gas appliance) or where there are sources of ignition (e.g. running electrical heating element).
- Before connecting the appliance to a power socket, check that the rated voltage on its rating label matches the electrical voltage in the power socket.
- Connect the appliance only to a properly grounded socket.
- The power socket must be freely accessible so that it is possible to quickly disconnect the power cord from the power source if necessary.
- The appliance is designed for use at home, in offices and similar types of areas. Do not use it in very dusty or humid rooms such as laundries or bathrooms, in areas where chemical or explosive substances are stored, in industrial surroundings or outdoors.
- Do not place the appliance in the vicinity of an open flame or appliances that are sources of heat.
- Do not place the appliance on unstable surfaces such as carpets with very long and thick fibres.
- The appliance may only be used on a dry, stable, smooth and horizontal surface.
- The appliance is equipped with travel wheels, so pay extra attention when handling it so that it does not fall down stairs or travel down from sloped areas. If necessary secure the wheels using the stoppers.
- Only use original parts to assemble the appliance. Before starting to assemble the appliance, make sure that it is turned off and disconnected from the power socket.

- Prior to connecting the appliance to a power socket, make sure that the appliance is correctly assembled according to the instructions in this user's manual.
- Do not touch the appliance with wet or damp hands. This applies especially when it is connected to a power socket.
- Do not expose the appliance to dripping or spraying water or submerge it in water or another liquid.
- Do not cover or insert anything into the air inlet or air outlet openings. Otherwise, this could damage the appliance.
- During operation there needs to be sufficient space for air circulation of at least 45 cm on all sides of the appliance.
- Do not expose yourself to a cold air current for a long time. This could have a negative effect on your health.
- To turn the appliance on or off, always use the appropriate buttons on the control panel or the remote control. Do not turn off the appliance by disconnecting the power cord from the power socket.
- Always turn off the appliance and disconnect it from the power socket when leaving it without supervision, when not using it and before moving, disassembling or cleaning it.
- Do not attempt to remove the outer case of the appliance.
- Disconnect the appliance from the power socket by pulling on the plug, never pulling on the power cord. Otherwise, this could damage the power cord or the socket.
- In the event that the power cord or power plug are damaged in any way, do not use the appliance.
- Store the appliance in a vertical position. It may be transported in a vertical position or tilted on the side. If you have already used the appliance, check that all the condensate has been drained. After transporting it, wait at least 1 hour before using the appliance.

- Do not use the appliance if it is not working correctly, if it has been damaged or has been submerged in water. To avoid a hazardous situation arising, do not repair the appliance yourself or modify it in any way. Have all repairs performed at an authorised service centre. By tampering with the appliance, you risk voiding your legal rights arising from unsatisfactory performance or quality warranty.
- Installation must be performed in accordance with the installation instructions. Incorrect installation may result in a water leak, injury by electrical shock or fire.
- To prevent the risk of fire or injury by electrical shock, do not use this appliance with a timer or any another similar device that could spontaneously start this appliance.
- The appliance must be installed in accordance with national electrical codes.
- Only use this product for the purposes that are described in this user's manual. Otherwise, this may result in damage or excessive noise and vibrations.
- Use only the accessories and components that are supplied together with the appliance and the tools explicitly intended for its installation. The use of nonstandard parts and accessories may result in a water leak, injury by electrical shock, fire, injury or damage to property.
- DO NOT ADJUST the length of the power cord of the unit and do not use an extension cord for its power supply.
- DO NOT CONNECT the unit to a power socket to which other electrical appliances are already connected. The incorrect selection of an electrical power supply may result in a fire or injury by electrical shock.
- Do not cover the cable with a carpet. Do not place carpets, fillets or any other floor coverings on the power cord. Do not locate the cable underneath furniture or appliances. Lead the

cable where nothing will ride over it and where nobody can trip over it. If this occurs, immediately disconnect the unit from the power socket.

- In the event that the unit is tipped over during use, turn it off and immediately disconnect it from the main power supply. Visually check that the unit has not been damaged in any way. In the event of any doubts that the unit has been damaged in any way, seek assistance from a technician or customer service.
- The power supply must be disconnected during a thunder storm to prevent damage to the appliance in the event of a lightning strike.
- Disconnect the power supply to the appliance if it makes a strange noise or if an odour or smoke is emitted.



Read this user's manual.



Warning:

Fire hazard.

SPECIFIC INFORMATION FOR APPLIANCES USING REFRIGERANT GAS R290

- Carefully study any warnings.
- For defrosting and cleaning, do not use any other tools than those recommended by the manufacturer.
- This appliance must be located in an environment that has no continuously running fire sources (for example an open fire, a gas appliance or electrical appliances).
- Do not perform any drilling and do not burn it.

- Refrigerant gases may be odourless.
- This appliance must be located in rooms with an area greater than 12,5 m².
- This appliance contains approx. 165 g of refrigerant gas R290.
- R290 is a refrigerant gas that meets European environmental protection directives. Do not make holes or drill into any part of the cooling circuit.
- The room in which this appliance is installed, operated or stored must prevent the accumulation of such leaked refrigerants, that could be the cause of explosion or fire as a result of the refrigerant igniting following the start-up of electrical heaters, cookers or other sources of ignition.
- The appliance must be stored in such a manner that its mechanical damage is prevented.
- Persons working with or repairing cooling circuits must have appropriate authorisation issued by an authorised institution that certifies this person's competence to work with refrigerants in accordance with the specific assessment of the association for this sector.
- Maintenance tasks must be performed solely on the basis of the recommendations of this appliance's manufacturer. Maintenance and repair tasks that required the contribution of other qualified expert personnel may only be performed under the supervision of specialised experts in the flammable refrigerants sector.
- Check the rating label for the type of refrigerant gas used in your appliance.
- Do not cover the vents.
- Follow the national gas regulations.

- Thank you for purchasing a SENCOR brand product and we hope that you will be happy with it.
- Prior to using this appliance, please read the user's manual thoroughly, even in cases, when one has already familiarised themselves with previous use of similar types of appliances. Only use the appliance in the manner described in this user's manual. Keep this user's manual in a safe place where it can be easily retrieved for future use.
- We recommend saving the original cardboard box, packaging material, purchase receipt and responsibility statement of the vendor or warranty card for at least the duration of the legal liability for unsatisfactory performance or quality. In the event of transportation, we recommend that you pack the appliance in the original box from the manufacturer.

- unstable or inclined surface from which the mobile air conditioner could slide, fall, become damaged or cause injury.
- The mobile air conditioner must be located so that it is not exposed to the direct sunshine.
- Make sure there are no heat sources (e.g., heating, portable heaters, stove, etc.) near where the mobile air conditioner will be located.
- For easier handling, the mobile air conditioner is equipped with castors. Do not use the castors when you need to move the air conditioner over carpets or similar surfaces. Avoid riding over objects.
- To achieve optimal efficiency, maintain a distance of at least 45 cm from the wall or other obstacles.
- Locate the mobile air conditioner well away from curtains, drapes, or blinds.
- Ensure the flexible hose does not touch any objects.

DESCRIPTION OF THE APPLIANCE

A1 Control panel	A7 Air outlet for connecting a flexible hose
A2 Remote control sensor	A8 Bottom protective grille of air inlet with filter
A3 Air outlet cover	A9 Power cord plug holder
A4 Handles (located on both sides)	A10 Drain outlet
A5 Castors	A11 Power cord
A6 Side protective grille of air inlet	



Note:

Do not use the mobile air conditioner to cool a room where computer servers, etc. are located. Installation, adjustment, maintenance and repairs must only be performed by a qualified person.

Installing the flexible hose on to the mobile air conditioner

The flexible hose must be connected to the mobile air conditioner and installed into a window in accordance with the operating modes that you wish to set. Install the flexible hose when you wish to select the operating modes: cooling, heating, dehumidification, or sleep mode. It is not necessary to install the flexible hose when you wish to select the fan mode.

1. Extend the flexible hose to the required length – see the figure **E1**.
2. Attach the adapter for connection to air outlet to one end of the flexible hose and screw counter clockwise – see the figure **E2**. Attach the window connection adapter to the other end of the flexible hose and screw counter clockwise – see the figure **E3**.
3. Place the flexible hose above the air outlet and move it downwards to fix it – see the figure **E4**.

Do not excessively bend or deform the flexible hose.

DESCRIPTION OF ACCESSORIES

B1 Adapter for connection to air outlet	B5 Remote control
B2 Flexible air exhaust hose	B6 Drain hose
B3 Window connection adapter	B7 Textile window seal kit
B4 Window insert	B8 Velcro

DESCRIPTION OF CONTROL PANEL

C1 Timer indicator	C6 + button
C2 Wi-Fi indicator	C7 Numeric display
C3 Operating mode indicators (cooling/dehumidification/fan)	C8 – button
C4 TIMER button for setting the timer	C9 MODE button for selecting an operating mode
C5 FAN SPEED button for setting the fan speed	C10 ON/OFF button for turning on/off

REMOTE CONTROL

D1 button for turning on/off	D6 button for decreasing the temperature
D2 button for selecting an operating mode	D7 button for setting the fan speed
D3 button for increasing the temperature	D8 button for changing the temperature units
D4 button for setting the timer	
D5 button for turning on/off the sleep mode	



Note:

If necessary, cut away a part of the window insert if the window is too small.

INSTALLATION

Location of the mobile air conditioner

- Remove the mobile air conditioner from the packaging and make sure you have removed all parts and accessories. We recommend that two adults remove the air conditioner from the packaging.
- Locate the mobile air conditioner on an even, dry and stable surface and within reach of a grounded power socket. Do not locate it on

Installing the flexible hose using the textile seal kit

The textile seal kit is suitable for tilt-open, sash and roof windows. The textile seal kit is fitted with a Velcro zip tape to make its installation in the window easier. Open the window and into the created crevice install the textile seal kit. We recommend that you thoroughly degrease the location where you will be attaching the textile seal kit using an appropriate cleaning agent. Remove the protective paper strip and stick the tape on to the window frame.

In order to be able to insert the flexible hose, the seal kit is fitted with an integrated zip. Open the zip in such a location that will enable you to easily insert the flexible hose.

It is not necessary to remove the textile seal kit from the window when not using the mobile air conditioner. The window can be closed even with the seal installed.



Note:

Avoid excessive bending of the hose. To ensure proper operation of the mobile air conditioner, it is important not to overload the hose or to bend it unnecessarily. Excessive loading or bending may damage the hose.

PUTTING INTO OPERATION

- Make sure the mobile air conditioner is correctly assembled and the flexible hose is properly attached in accordance with the instructions above.
- Make sure the mobile air conditioner is located in a suitable place at a sufficient distance from the power socket.
- Insert the power plug into a properly grounded power socket.
- Mobile air conditioner is put into the standby mode.

CONTROLS OF THE MOBILE AIR CONDITIONER

A. CONTROL PANEL

Turning the mobile air conditioner on/off

- Press shortly the **ON/OFF** button and the mobile air conditioner will turn on and start at the setting in which it was last turned off.
- Press the **ON/OFF** button again the turn the mobile air conditioner off and switch to the standby mode. To turn it off completely, disconnect the power plug from the power socket.



Warning:

Do not turn the mobile air conditioner on straight after turning off. Wait a few minutes before turning on. Otherwise, the compressor may be damaged.



Note:

Never turn off the mobile air conditioner by pulling the power cord out of the power socket. Turn off the mobile air conditioner using the **ON/OFF** button, wait a few minutes and then pull out the power cord.

Operating modes

1. Cooling mode

- Press the **MODE** button repeatedly until the **COOL** indicator is lit on the control panel.
- Use the +/- buttons to set the desired temperature. The temperature can be set in the range of 18–32 °C.
- Use the **FAN SPEED** button to set the fan speed. Pressing the **FAN SPEED** button repeatedly, you will switch the speed in the following order: High (high speed) – Low (low speed).

2. Dehumidification mode

- Press the **MODE** button repeatedly until the **DRY** indicator is lit on the control panel.
- In this mode, the humidity in the room is reduces. The condensed humidity accumulates in the tank. For the methods of condensate drainage, refer to the “**CONDENSATE DRAINAGE**” section further in this manual.
- It is not possible to set the temperature or fan speed in this mode. The fan speed is automatically set to a low speed.

3. Fan mode

- Press the **MODE** button repeatedly until the **FAN** indicator is lit on the control panel.
- In this mode, the fan will circulate the air in the room, but it will not cool it.
- Use the **FAN SPEED** button to set the fan speed. Pressing the **FAN SPEED** button repeatedly, you will switch the speed in the following order: High (high speed) – Low (low speed).

Timer function

The mobile air conditioner enables to set two different timers – turn-on timer and turn-off timer of the mobile air conditioner.

a) Turn-on timer of the mobile air conditioner

Turn-on timer of the mobile air conditioner allows you to turn on the mobile air conditioner after a set period. Turn on the mobile air conditioner, select the operating mode and temperature and turn off the mobile air conditioner.

When the mobile air conditioner is in standby mode, press the **TIMER** button. The numeric display will flash, and the time indicator will be lit. Use +/- buttons to set the time after which the mobile air conditioner will turn on. You can set the time in the range from 0,5 to 24 hours. Wait about 5 seconds till the time is stored in the memory. Then, the automatic countdown of the set period will start.

Once the set time has elapsed, the mobile air conditioner starts in the last operating mode.

b) Turn-off timer of the mobile air conditioner

Turn-off timer of the mobile air conditioner allows you to turn off the mobile air conditioner after a set period.

When the mobile air conditioner is on, press the **TIMER** button. The numeric display will flash, and the time indicator will be lit.

Use +/- buttons to set the time after which the mobile air conditioner will turn on. You can set the time in the range from 0,5 to 24 hours. Wait about 5 seconds till the time is stored in the memory. Then, the automatic countdown of the set period will start.

Once the set time has elapsed, the mobile air conditioner turns off and switches to the standby mode.

When you need to cancel the timer, press the **TIMER**. The remaining time will start flashing. Press **TIMER** button again and the timer will be cancelled or press **ON/OFF**.

Temperature unit change

While the mobile air conditioner is on, long press the +/- simultaneously for 3 seconds to change the temperature units from °C to °F and vice versa.

B. REMOTE CONTROL

Inserting and replacing batteries

Slide out the battery compartment cover, which is located on the rear side of the remote control. Place two AAA/LR03 (2x1.5V) alkaline batteries into the battery compartment and close the cover.

When inserting the batteries ensure the correct polarity as shown in the battery compartment.

When replacing the batteries, always use batteries of the same type, never combine old and new batteries or batteries of various types.



Note:

Removing the batteries from the remote control will delete all the settings. After new batteries are inserted the default remote control settings as programmed by the manufacturer will be renewed.

If you will not be using the remote control for longer than 2 months, remove the batteries.



Warning:



Dispose the used batteries in accordance with the locally applicable laws. Do not dispose batteries in common household waste. Do not use old and new batteries at the same time. Do not use alkaline, standard, or rechargeable batteries at the same time. Do not throw batteries into fire. They may explode, or leak.

Using the remote control

For the remote control to work correctly, ensure that the maximum distance of the remote control from the mobile air conditioner is not greater than 7 m and that there is no obstacle between the remote control and the mobile air conditioner that could prevent the transmission of the signal.

Point the remote control directly at the mobile air conditioner. The transmission of the signal is confirmed by a short sound signal. Do not expose the remote control to direct sunlight or high temperatures. Otherwise, the signal may not be transmitted.

Turning the mobile air conditioner on/off

- Press shortly the  button and the mobile air conditioner will turn on and start at the setting in which it was last turned off.
- Press the  button again the turn the mobile air conditioner off and switch to the standby mode. To turn it off completely, disconnect the power plug from the power socket.



Warning:

Do not turn the mobile air conditioner on straight after turning off. Wait a few minutes before turning on. Otherwise, the compressor may be damaged.







Note:

Never turn off the mobile air conditioner by pulling the power cord out of the power socket. Turn off the mobile air conditioner using the  button, wait a few minutes and then pull out the power cord.

Operating modes



1. Cooling mode

- Press the  button repeatedly until the **COOL** indicator is lit on the display.
- Use the  buttons to set the desired temperature. The temperature can be set in the range of 18–32 °C.
- Use the  button to set the fan speed. Pressing the  button repeatedly, you will switch the speed in the following order: High (high speed) – Low (low speed).

2. Dehumidification mode

- Press the  button repeatedly until the **DRY** indicator is lit on the display.
- In this mode, the humidity in the room is reduces. The condensed humidity accumulates in the tank. For the methods of condensate drainage, refer to the “**CONDENSATE DRAINAGE**” section further in this manual.
- It is not possible to set the temperature or fan speed in this mode. The fan speed is automatically set to a low speed.

3. Fan mode

- Press the  button repeatedly until the indicator is lit on the display.
- In this mode, the fan will circulate the air in the room, but it will not cool it.
- Use the  button to set the fan speed. Pressing the  button repeatedly, you will switch the speed in the following order: High (high speed) – Low (low speed).

Functions of the mobile air conditioner

1. Timer function

The mobile air conditioner enables to set two different timers – turn-on timer and turn-off timer of the mobile air conditioner.

a) Turn-on timer of the mobile air conditioner

Turn-on timer of the mobile air conditioner allows you to turn on the mobile air conditioner after a set period. Turn on the mobile air conditioner, select the operating mode and temperature and turn off the mobile air conditioner.

When the mobile air conditioner is in standby mode, press the  button. The numeric display will flash, and the time indicator will be lit.

Use  buttons to set the time after which the mobile air conditioner will turn on. You can set the time in the range from 0,5 to 24 hours.

Wait about 5 seconds till the time is stored in the memory. Then, the automatic countdown of the set period will start.

Once the set time has elapsed, the mobile air conditioner starts in the last operating mode.

b) Turn-off timer of the mobile air conditioner



Turn-off timer of the mobile air conditioner allows you to turn off the mobile air conditioner after a set period.

When the mobile air conditioner is on, press the  button. The numeric display will flash, and the time indicator will be lit.

Use  buttons to set the time after which the mobile air conditioner will turn on. You can set the time in the range from 0,5 to 24 hours.

Wait about 5 seconds till the time is stored in the memory. Then, the automatic countdown of the set period will start.

Once the set time has elapsed, the mobile air conditioner turns off and switches to the standby mode.

When you need to cancel the timer, press the . The remaining time will start flashing. Press  button again and the timer will be cancelled or press .

2. Sleep function

The sleep function is used to reduce the energy consumption during the night when a constant temperature is not required. The function also ensures comfort during sleep, as the operation of the air conditioner is muted, and the display is dimmed.

Choose the operating mode cooling set the start temperature. Then press the  button to turn on the sleep function.

The fan speed is automatically set to a low speed while the temperature and relative humidity can be gradually change to ensure maximum comfort during sleep.

After two hours of the sleep mode operation, the temperature will increase by 1 °C for one hour. The mobile air conditioner will maintain this new temperature for next 6 hours and then, it is turned off.

The sleep function can be cancelled at any time by pressing the button, selecting the operating mode or setting the fan speed.

The sleep function is not available for fan mode.

Temperature unit change

Press the  button to change the temperature units from °C to °F and vice versa.

C. CONTROL VIA THE SENCOR HOME APPLICATION

This mobile air conditioner can be controlled via the Sencor HOME application.

Download the application to your smart phone, register yourself and control the mobile air conditioner via the application.

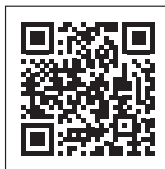

If you already have the application installed, add the mobile air conditioner to your devices.

Adding the mobile air conditioner to the list of appliances via Bluetooth

You can add the mobile air conditioner to the Sencor HOME application by pairing it via Bluetooth.

1. Turn on the Bluetooth function on your mobile phone.
2. Turn on the mobile air conditioner.
3. Open the application and on the home screen of the application, click on the icon .
4. The appliance will automatically offer the options »Do not add / Go to Add«.
5. Click on »Go to Add« and the application will automatically guide you through the addition.



Note:

If the Bluetooth connection fails or is not possible, check that there are no solid obstacles between your phone and the mobile air conditioner and that both devices are close to each other.

Adding the mobile air conditioner to the list of appliances via a QR code

The mobile air conditioner can also be added to the Sencor HOME application using the QR code provided below. On the home screen of the application, click on the “+” icon and on the Add device screen, click on the  icon in the top right hand corner.

QR code for adding the control panel of the mobile air conditioner to the application Sencor HOME



Manually adding the mobile air conditioner to the device list

On the main screen, click on "Add device" or on the "+" in the top right hand corner.

A screen with appliance categories will appear together with a list of appliances.

Click on "Cooling" and select the mobile air conditioner model from the list of products.

On the next screen, you will be asked to select a Wi-Fi network. Select a network, enter the password and click on "Next".

Ensure that the mobile air conditioner is ready for pairing. It is important that the mobile air conditioner is connected to a power source and is in stand-by mode. The Wi-Fi indicator will start to flash quickly on the control panel. If the indicator does not start flashing, perform the Wi-Fi reset (see "Wi-Fi reset below"). In the application, confirm that the Wi-Fi indicator is quickly flashing and click on "Next". The mobile air conditioner will automatically be added to the device list. The Wi-Fi indicator will be lit.

In the device list on the main screen, click on the icon of the mobile air conditioner to enter its control interface.

Wi-Fi reset

There are three ways to reset Wi-Fi:

1. Press the **FAN SPEED** button on the control panel 6 times within 4 seconds;
2. Hold the **ON/OFF** button on the control panel for about 5 seconds;
3. Hold the **MODE** button on the control panel for about 3 seconds.

CONDENSATE DRAINAGE

The mobile air conditioner is equipped with a drain outlet. In the case of a frequent use of the mobile air conditioner, it is necessary to regularly check the quantity of condensate and drain it. If you choose the dehumidification mode, we recommend draining the condensate using a drain hose.



Note:

In cooling and fan operating mode (provided low humidity in the room), it may not be necessary to drain the condensate. The mobile air conditioner is designed to increase the efficiency with a small amount of water in the condensate tank.

Manual condensate drainage

When the water level in the tank reaches the preset level, the operation of the mobile air conditioner will stop, a beep will sound, and the display will show "Ft" (full tank). To drain the condensate from the air conditioner, proceed as follows:

1. Disconnect the power plug from the power socket.
2. Carefully re-locate the mobile air conditioner to a location where the water may be drained.
3. Underneath the drain outlet, place a container into which the condensate will flow – see the figure **G1**. Carefully remove the plug of the drain outlet. Connect the drain hose if needed and allow the condensate to flow out. You may tilt the mobile air conditioner slightly backwards while draining the condensate.
4. Once the water tank is empty (condensate has stopped flowing), disconnect the drain hose if used, and put the plug back into the drain outlet. Before turning on the mobile air conditioner again, make sure that plug of the drain outlet is correctly inserted, and seals well. Otherwise, condensate could leak during the operation, and it could damage the floor or carpet.

5. Insert the power plug into a power socket and turn on the mobile air conditioner.



Note:

If you turn off the mobile air conditioner by **ON/OFF** button, the operation will not be restored automatically, and it will be necessary to set it again.



Note:

If the mobile air conditioner is added to the list of devices in the Sencor HOME application, a full tank warning will also be displayed directly in the application, as well as other warning messages.

Continuous condensate drainage

The top drain hole is used for continuous draining.

1. Disconnect the power plug from the power socket.
2. Remove the plug of the drain outlet. Connect the drain hose – see the figure **G2**. If the length of the drain hose is insufficient, then it is necessary to purchase a longer hose of the same type. Never extend the length of the drain hose using extensions.
3. Connect the end of the drain hose to the waste water drain.
4. Insert the power plug into a power socket and turn on the mobile air conditioner.



Note:

The drain hose should be installed at the same height or lower than the top drain outlet. Otherwise, the condensate will not be properly drained from the water tank.

SAFETY PROTECTION FEATURES

Acoustic warning and shutdown when tank is full (Ft)

When the water level in the tank reaches the preset level, the operation of the mobile air conditioner will stop, a beep will sound, and the display will show "Ft" (full tank).

The tank must be emptied. Follow the instructions in the "**CONDENSATE DRAINAGE**" section.

COMPRESSOR PROTECTION

The compressor is equipped with time protection against damage when it is switched on again, lasting 3 minutes. If the mobile air conditioner is switched on shortly after it has been switched off, the compressor will only start running after 3 minutes.

Room temperature sensor and coil (PF) failure

1. Detects sensor failure during power-up or operation.
2. When a power-on fault is detected, it will immediately put the mobile air conditioner into an error state and display "PF". If operation returns to normal at this time, the mobile air conditioner will switch to standby mode. If the problem persists, contact an authorized service centre.

TIPS FOR CORRECT USAGE

To ensure the correct usage of the mobile air conditioner, we recommend that you observe the following:

- Close all windows and doors of the room where you are using the mobile air conditioner. If you have installed the mobile air conditioner in the room only temporarily, you can leave the door slightly ajar (about 1 cm) to ensure proper ventilation.
- Avoid direct sunlight entering the room. Close the curtains or blinds to ensure economical operation of the air conditioner.
- Do not block the air outlet and inlet openings.
- Make sure that no heat source is turned on in the room.
- Never use the mobile air conditioner in a very humid environment, such as laundry rooms.
- Never use the mobile air conditioner outdoors.
- Make sure the mobile air conditioner is placed on a flat surface. If necessary, install special brakes on the travel wheels.

MAINTENANCE AND CLEANING

Before cleaning the mobile air conditioner, turn it off and wait a few minutes, and then pull the power cord out of the power socket.

Cleaning the protective grilles and air filters

When the mobile air conditioner is used regularly, it is necessary to clean the protective grilles and air filters at least once every 14 days to prevent the fan from being clogged by dust.

Carefully remove the protective grilles and remove the filters – see the figure **H**. To remove the dust, use a vacuum cleaner.

In the event of greater soiling, wash the filters in a solution of lukewarm water (max. 40 °C) and neutral detergent. Then thoroughly rinse under running water and allow to dry naturally. Do not dry it in a clothes dryer or in direct sunlight. Once the filters are dry, you can install them back in their place.

In the event of greater soiling, you can wipe the protective grilles with a slightly damp cloth and wipe dry with a clean cloth.



Note:

Do not use the mobile air conditioner without the air filters and protective grilles properly installed and do not use it with wet or damp air filters.

Cleaning the outer case

To clean the outer case, use a soft wiping cloth dipped in a solution of lukewarm water and neutral detergent. Then wipe the surface dry.

When cleaning it, do not spray the mobile air conditioner with water or any other liquid, do not pour water on it or submerge it in water or in any other liquid.

Do not use abrasive cleaning products, solvents, petrol, etc. for cleaning.

Storing the mobile air conditioner

In order to dry it and to prevent the formation of moulds, leave the mobile air conditioner running in a warm room in the fan mode for approximately 12 hours.

Disconnect the flexible hose and store it in a safe place out of the reach of children.

Drain all the condensate from the water tank – see chapter

„CONDENSATE DRAINAGE“.

Clean the air filters and reinstall them. Wipe the outer case of the mobile air conditioner. Remove the batteries from the remote control.

Store the air conditioner in a cool, dry and dark location.

Putting into operation again

Check that the power cord and plug are not damaged and that the air filters are clean. Insert a new set of batteries into the remote control.

Proceed according to the instructions in section „**Inserting and replacing batteries**“. Install the mobile air conditioner according to the instructions contained in the preceding part of this user's manual „**Installation**“.

.....

TROUBLESHOOTING

Before contacting an authorised service centre, please check the appliance according to the following instructions:

Problem	Possible cause	Solution
The mobile air conditioner does not turn on.	The power cord is not plugged in the power socket, or the power socket is energised.	Connect the power plug correctly to the power socket, or check the power socket is energised.
	The water tank is full.	Empty the water tank according to the instruction in the “CONDENSATE DRAINAGE” section.
	The room temperature is too low or high.	We recommend using the mobile air conditioner at temperature range from 5 °C to 35 °C.
	The room temperature is lower than the set temperature (cooling mode).	Adjust the set temperature.
The internal safety device has been tripped.		Wait about 30 minutes and then try to turn on the air conditioner again. If the problem persists, contact the authorised service centre.
The mobile air conditioner does not cool enough.	The mobile air conditioner is exposed to the direct sunshine.	Re-locate the mobile air conditioner or dim it.
	Room windows and doors of the room are open and warm air flows into the room, or heat sources are on in the room.	Ensure all windows and doors are closed, or turn off heat sources.
	The air filter is dirty.	Turn off the air conditioner and clean the air filter according to the instructions in the “Cleaning air filters” section.
The air inlets or outlets are blocked.		Remove the cause of the blockage.
The mobile air conditioner works for a short time only.	The flexible hose is excessively bended.	Straighten the flexible hose so that there are no bends.
	Air outlet is blocked.	Unblock the air outlet.
The mobile air conditioner is too noisy.	The air conditioner is located on an uneven surface.	Turn off the air conditioner, unplug from the power outlet and move it to flat and level surface.
Compressor does not work.	The compressor protection has been activated.	Wait 3 minutes. Then, the operation will automatically start. It is a normal phenomenon.
During operation, there is unpleasant smell in the room.	The air filter is soiled.	Turn off the air conditioner and clean the air filter according to the instructions in the “Cleaning air filters” section.
The remote control does not work.	The distance between the remote control and mobile air conditioner is too big.	Approach the mobile air conditioner and make sure there are no obstacles between the control and the mobile air conditioner.
	The remote control does not point at the signal sensor.	
	Batteries are discharged.	Change the batteries.

Error messages

Error messages on the display	Meaning	Solution
PF	Probe failure	Wait, and if the operation returns to normal at this time, the mobile air conditioner will switch to standby mode. If the problem persists, contact an authorized service centre.
Ft	Condensate tank is full.	Empty the condensate tank according to the instructions in "CONDENSATE DRAINAGE" section.



Note:

In the event that one of the aforementioned faults occurs, turn off the mobile air conditioner and check for the cause of the fault. Turn it on again, and if the fault reoccurs, turn it off, disconnect the power cord from the power socket and contact the manufacturer, an authorised service centre or a person with relevant qualifications and have the unit repaired.

TECHNICAL SPECIFICATIONS

Power supply	220-240 V~ / 50 Hz
Cooling power	2600 W
Cooling power input	1000 W
EL Current draw (cooling)	4.5 A
Rated power	1300 W
Rated current	6.5 A
GWP cooling factor	3
Dehumidification capacity	13 l/day
Capacity of the built-in condensate tank	0.45 l
Refrigerant type and weight	R290/165 g
Air flow volume	320/260 m ³ /hour (high/low)
Acoustic power value	54/51 dB (A) (high/low)
Sound pressure value	65/63 dB (A) (high/low)
Maximum permitted value of operating pressure (low/high)	1.2/2.3 MPa
Dimensions of the mobile air conditioner (w × d × h)	280×290×675 mm
Weight	20.8 kg
Operating temperature (cooling)	18 to 32 °C
Recommended room area (Central Europe)*	31–35 m ²
Recommended room size (Central Europe)*	80–91 m ³ (ceiling height 2.6 m)

*Applies for the calculated climatic conditions value typical for Central Europe. For standard rooms with ceilings at standardised heights. The provided values may differ when the appliance is used in sectioned areas, in areas with multiple heat sources, heavily glazed or/and poorly insulated areas.

If you know that you are purchasing the air conditioner for an area with the above-described characteristics, select a model with a higher power output for the given area.

The declared noise emission level of the appliance is 65/63 dB(A), which represents a level A of sound power with respect to a reference sound power of 1 pW.



Note:

The efficiency of the mobile air conditioner may be reduced in the event that it is used outside the above-described operating temperature range.

We reserve the right to change text and technical specifications.

DISPOSAL OF USED BATTERIES



Batteries contain environmentally damaging compounds and, therefore, do not belong in standard communal waste. Hand over used batteries for proper disposal at locations intended for their collection.

SENCOR hereby declares that radio device model number SAC MT9014C is in compliance with directive 2014/53/ EU. The full wording of the EU Declaration of Conformity is available at the website: www.sencor.eu.

INSTRUCTIONS AND INFORMATION REGARDING THE DISPOSAL OF USED PACKAGING MATERIALS

Dispose of used packaging material at a site designated for waste in your municipality.

DISPOSAL OF USED ELECTRICAL AND ELECTRONIC EQUIPMENT



This symbol on products or original documents means that used electric or electronic products must not be added to ordinary municipal waste. For proper disposal, renewal and recycling, hand these products over to determined collection points. Alternatively, in some European Union states or other European countries you may return your products to the local retailer when buying an equivalent new product. Correct disposal of this product helps save valuable natural resources and prevents potential negative effects on the environment and human health, which could result from improper waste disposal. Ask your local authorities or collection facility for more details. In accordance with national regulations penalties may be imposed for the incorrect disposal of this type of waste.

For business entities in European Union states

If you want to dispose of electrical or electronic equipment, ask your retailer or supplier for the necessary information.

Disposal in other countries outside the European Union.

This symbol is valid in the European Union. If you wish to dispose of this product, request the necessary information about the correct disposal method from the local council or from your retailer.



This product meets all the basic requirements of EU directives related to it.

FAST ČR, a.s.
U Sanitasu 1621
CZ-251 01 Říčany
www.sencor.eu