



DRAPER[®]

AIR

BODY SAW

70833



These instructions accompanying the product are the original instructions. This document is part of the product, keep it for the life of the product passing it on to any subsequent holder of the product. Read all these instructions before assembling, operating or maintaining this product.

This manual has been compiled by Draper Tools describing the purpose for which the product has been designed, and contains all the necessary information to ensure its correct and safe use. By following all the general safety instructions contained in this manual, it will ensure both product and operator safety, together with longer life of the product itself.

All photographs and drawings in this manual are supplied by Draper Tools to help illustrate the operation of the product.

Whilst every effort has been made to ensure the accuracy of information contained in this manual, the Draper Tools policy of continuous improvement determines the right to make modifications without prior warning.

1. TITLE PAGE

1.1 INTRODUCTION:

USER MANUAL FOR: Air Body Saw

Stock No's: 70833

Part No's: DAT-ABSSG

1.2 REVISIONS:

Date first published July 2019.

As our user manuals are continually updated, users should make sure that they use the very latest version.

Downloads are available from: <http://drapertools.com/manuals>

Draper Tools Limited
Hursley Road
Chandler's Ford
Eastleigh
Hampshire
SO53 1YF
UK

Website: drapertools.com

Product Helpline: +44 (0) 23 8049 4344

General Fax: +44 (0) 23 8026 0784

1.3 UNDERSTANDING THIS MANUALS SAFETY CONTENT:

WARNING! – Information that draws attention to the risk of injury or death.

CAUTION! – Information that draws attention to the risk of damage to the product or surroundings.

1.4 COPYRIGHT © NOTICE:

Copyright © Draper Tools Limited.

Permission is granted to reproduce this publication for personal and educational use only. Commercial copying, redistribution, hiring or lending is prohibited.

No part of this publication may be stored in a retrieval system or transmitted in any other form or means without written permission from Draper Tools Limited.

In all cases this copyright notice must remain intact.

2. CONTENTS

1. TITLE PAGE

1.1 INTRODUCTION	2
1.2 REVISION HISTORY	2
1.3 UNDERSTANDING THIS MANUAL	2
1.4 COPYRIGHT NOTICE	2

2. CONTENTS

2.1 CONTENTS	3
--------------------	---

3. WARRANTY

3.1 WARRANTY.....	4
-------------------	---

4. INTRODUCTION

4.1 SCOPE.....	5
4.2 SPECIFICATION	5

5. HEALTH AND SAFETY INFORMATION

5.1 GENERAL SAFETY INSTRUCTIONS FOR POWER TOOL USE	6
5.2 GENERAL SAFETY INSTRUCTIONS FOR COMPRESSED AIR	7
5.3 SPECIFIC SAFETY INSTRUCTIONS FOR AIR BODY SAWS.....	8
5.4 RESIDUAL RISK	9

6. TECHNICAL DESCRIPTION

6.1 IDENTIFICATION	10
--------------------------	----

7. UNPACKING AND CHECKING

7.1 PACKAGING	11
7.2 WHAT'S IN THE BOX?.....	11

8. AIR SUPPLY

8.1 AIR TOOL OIL SPECIFICATION	12
8.2 RECOMMENDED AIR SUPPLY SET UP.....	12

9. ASSEMBLY

9.1 CONNECTION TO THE AIR SUPPLY.....	13
9.2 REPLACEMENT OF SAW BLADE.....	13
9.3 ADJUSTING THE WORK GUARD.....	13

10. OPERATION

10.1 OPERATION	14
----------------------	----

11. MAINTENANCE

11.1 EVERY-DAY MAINTENANCE CHECKS	15
11.2 AFTER USE MAINTENANCE CHECKS	15

12. TROUBLESHOOTING

12.1 TROUBLESHOOTING GUIDE.....	16
---------------------------------	----

13. EXPLANATION OF SYMBOLS

13.1 EXPLANATION OF SYMBOLS	17
-----------------------------------	----

14. DISPOSAL

14.1 DISPOSAL	18
---------------------	----

DECLARATION OF CONFORMITY ENCLOSED

3. WARRANTY

3.1 WARRANTY

Draper tools have been carefully tested and inspected before shipment and are guaranteed to be free from defective materials and workmanship.

Should the tool develop a fault, please return the complete tool to your nearest distributor or contact

Draper Tools Limited, Chandler's Ford, Eastleigh, Hampshire, SO53 1YF. England.

Telephone Sales Desk: (023) 8049 4333 or Product Help Line (023) 8049 4344.

A proof of purchase **must** be provided with the tool.

If upon inspection it is found that the fault occurring is due to defective materials or workmanship, repairs will be carried out free of charge. This warranty period covering parts/labour is 6 months from the date of purchase except where tools are hired out when the warranty period is 90 days from the date of purchase. This warranty does not apply to any consumable parts, any type of battery or normal wear and tear, nor does it cover any damage caused by misuse, careless or unsafe handling, alterations, accidents, or repairs attempted or made by any personnel other than the authorised Draper warranty repair agent.

Note: If the tool is found not to be within the terms of warranty, repairs and carriage charges will be quoted and made accordingly.

This warranty applies in lieu of any other warranty expressed or implied and variations of its terms are not authorised.

Your Draper warranty is not effective unless you can produce upon request a dated receipt or invoice to verify your proof of purchase within the warranty period.

Please note that this warranty is an additional benefit and does not affect your statutory rights.

Draper Tools Limited.

4. INTRODUCTION

4.1 SCOPE

Straight cutting or scroll cutting on mild steel up to 1.2mm thick. Any other use other than that it was designed for is considered misuse.

4.2 SPECIFICATION

Stock no.	70833
Part no.	DAT-ABSSG
Strokes per minute	10,000s/min
Working air pressure	90psi (6.2bar)
Average air consumption	2.5cfm
Min. air line size (inner Ø)	3/8" (10mm)
Air inlet	1/4" BSP
Sound pressure level*	TBCdB(A)
Sound power level**	TBCdB(A)
Vibration level	TBCm/s ²
Weight (air tool only).....	0.64kg

Warning!

- Wear safety glasses and ear defenders.

* *Continuous A-Weighted Sound Pressure Level at the workstation in accordance to prEN ISO 15744:1999 and declared according to EN ISO 4871.*

** *A-Weighted Sound Power Level in accordance to prEN ISO 15744:1999 and declared according to EN ISO 4871.*



5. HEALTH AND SAFETY INFORMATION

5.1 GENERAL SAFETY INSTRUCTIONS FOR POWER TOOL USE

When using any type of power tool there are steps that should be taken to make sure that you, as the user, remain safe.

Common sense and a respect for the tool will help reduce the risk of injury.

Read the instruction manual fully. Do not attempt any operation until you have read and understood this manual.

Most important you must know how to safely start and stop this machine, especially in an emergency.

Keep the work area tidy and clean. Attempting to clear clutter from around the machine during use will reduce your concentration. Mess on the floor creates a trip hazard. Any liquid spilt on the floor could result in you slipping.

Find a suitable location. If the machine is bench mounted; the location should provide good natural light or artificial lighting as a replacement. Avoid damp and dust locations as it will have a negative effect on the machine's performance. If the machine is portable; do not expose the tool to rain. In all cases do not operate power tools near any flammable materials.

Keep bystanders away. Children, onlookers and passers by must be restricted from entering the work area for their own protection. The barrier must extend a suitable distance from the tool user.

Disconnect and house all power tools that are not in use. An air tool should never be left unattended while connected to the power supply. They must be housed in a suitable location, away locked up and from children.

Do not overload or misuse the tool. All tools are designed for a purpose and are limited to what they are capable of doing. Do not attempt to use a power tool (or adapt it in any way) for an application it is not designed for. Select a tool appropriate for the size of the job. Overloading a tool will result in tool failure and user injury: This covers the use of accessories.

Dress properly. Loose clothing, long hair and jewellery are all dangerous because they can become entangled in moving machinery: This can also result in parts of body being pulled into the machine. Clothing should be close fitted, with any long hair tied back and jewellery and neck ties removed. Footwear must be fully enclosed and have a non-slip sole.

Wear personal protective equipment (PPE). Dust, noise, vibration and swarf can all be dangerous if not suitably protected against. If the work involving the power tool creates dust or fumes; wear a dust mask. Vibration to the hand, caused by operating some tools for longer periods must be protected against. Wear vibration reducing gloves and allow long breaks between uses. Protect against dust and swarf by wearing approved safety goggles or a face shield. These are some of the more common hazards and preventions; however, always find out what hazards are associated with the machine/work process and wear the most suitable protective equipment available.

Do not breathe contaminated air. If the work creates dust or fumes; connect the machine (if possible) to an extraction system either locally or remotely. Working outdoors can also help if possible.

Move the machine as instructed. If the machine is hand held, do not carry it by the air line. If the product is heavy; employ a second or third person to help move it safely or use a mechanical device. Always refer to the instructions for the correct method.

Do not overreach. Extending your body too far can result in a loss of balance and you falling. This could be from a height or onto a machine and will result in injury.

Maintain your tools correctly. A well maintained tool will do the job safely. Replace any damaged or missing parts immediately with original parts from the manufacturer. As applicable; keep blades sharp; moving parts clean, oiled or greased; handles clean; and emergency devices working.

5. HEALTH AND SAFETY INFORMATION

Wait for the machine to stop. Unless the machine is fitted with a safety brake; some parts may continue to move due to momentum. Wait for all parts to stop; then disconnect it from the air line before making any adjustments, carrying out maintenance operations or just finishing using the tool.

Remove and check setting tools. Some machinery requires the use of additional tools or keys to set, load or adjust the power tool. Before starting the power tool always check to make certain they have been removed and are safely away from the machine.

Prevent unintentional starting. Before connecting any machine in to the air supply, make sure the switch is in the OFF position. If the machine is portable; do not hold the machine near the switch and take care when putting the machine down; that nothing can operate the switch.

Concentrate and stay alert. Distractions are likely to cause an accident. Never operate a power tool if you are under the influence of drugs (prescription or otherwise), including alcohol or if you are feeling tired. Being disorientated will result in an accident.

Have this tool repaired by a qualified person. This tool is designed to conform to the relevant international and local standards and as such should be maintained and repaired by someone qualified; using only original parts supplied by the manufacturer: This will ensure the tool remains safe to use.

5.2 GENERAL SAFETY INSTRUCTIONS FOR COMPRESSED AIR

Following Safety instructions should be strictly followed. Failure to do so may result in accidents, equipment malfunctioning, serious personal injury and / or loss of life.

Compressed air is a source of considerable energy. When handling products dealing with compressed air, the following precautions must be taken to prevent accidents.

1. Ensure that compressed air is not blocked or in contact with any part of your body.
2. Before connecting any pneumatic equipment to the compressed air supply, all mounted fittings, piping assemblies and electrical connections should be checked for security. All plastic plugs in the equipment used for protection during shipping should be removed.
3. No piping alterations, removal of fittings, repairing of equipment etc. Should be attempted with air supplies connected. Air and electrical supplies must be disconnected before beginning any adjustment, maintenance or dismantling of equipment.
4. The maximum allowable operating pressures, temperature, flows etc. must be strictly observed. Failure to do so might result in catastrophic failure of equipment, and result in serious personal injury and / or death. Refer to individual catalogues for this information, and any other operating or application limitations.

WARNING:

1. Compatibility of pneumatic equipment
Ensuring the compatibility of the procured FRL equipment is the responsibility of the person who designs the Pneumatic system and/ or System specifications. This should be based on specifications or after analysis and / or tests to meet specific requirements.
2. Repair & Maintenance
Assembly, handling, or repair of pneumatic systems should be performed by only trained and experienced operators.
3. Safety First
Do not service machinery / equipment or attempt to remove any component until safety is confirmed.
 - i. Inspection and maintenance of machinery / equipment should only be performed after confirmation that both compressed air and electrical supply have been positively disconnected and all residual compressed air in the system has been completely exhausted to the atmosphere.
4. Contact the manufacturer if equipment is to be used in any of the following conditions:

5. HEALTH AND SAFETY INFORMATION

- i. Equipment is to be used in conditions beyond the given specifications, or if equipment is to be used outdoors.
- ii. Equipment is to be used in conjunction with atomic energy, railroad, air navigation, automobiles or related vehicles, medical equipment or safety equipment.
- iii. In applications that adversely affect humans, animals, or property requiring special safety analysis.

5.3 SPECIFIC SAFETY INSTRUCTIONS FOR AIR BODY SAWS

- Air powered equipment and power tools are capable of propelling materials such as fasteners, metal chips and other debris at high speed which could result in serious eye injury.
- Compressed air can be hazardous. The air system can cause injury to soft tissue areas such as eyes, ears etc. Particles or objects propelled by the stream can cause injury.
- Tool attachments can become loose or break and fly apart propelling articles at the operator and others in the work area. Make sure that any attachments are securely assembled.
- Tools are capable of generating sparks, which could result in ignition of flammable materials. Never operate tools near flammable substances such as gasoline, cleaning solvents etc. Work in a clean and well ventilated area free of combustible materials. Never use oxygen, carbon dioxide or other bottled gases as a power source for air tools.
- Exceeding the maximum pressure rating of tools or accessories could cause an explosion resulting in serious injury. Use compressed air regulated to a maximum pressure at or below the rated pressure of any attachments. Never connect an air source that is capable of exceeding 200psi.
- Long term exposure to noise produced from the operation of air tools can lead to permanent hearing loss. Always wear protection.
- Tools generate dust and abrasive materials, which can be harmful to human lungs and respiratory system. Always wear protection. Some materials such as adhesives and tar contain chemicals whose vapours could cause serious injury with prolonged exposure. Always work in a clean, dry, well ventilated area.
- A tool left unattended, or with the air hose attached, can be activated by unauthorized persons leading to their injury or injury to others. Remove air hose when tool is not in use and store tool in secure location away from reach of children and intrained users.
- Air tools can propel fasteners or other materials throughout the work area. Use only parts, fasteners and accessories recommended by the manufacturer. Keep the work area clean and free of clutter. Keep children and others away from tool while it is in operation.
- A wrench or a key that is left attached to a rotating part of the tool increases the risk of personal injury. Remove adjusting keys and wrenches before turning the tool on.
- Using inflator nozzles for duster applications can cause serious injury. DO NOT use inflator nozzles for duster applications.
- Air tools can become activated by accident during maintenance or tool changes. Remove air hose to lubricate or add grinding attachments, sanding discs, drills, etc. to the tool. Never carry the tool by hose. Avoid unintentional starting. Don't carry hook-up tool with finger on trigger. Only an authorized service representative should do repair servicing.
- Air tools can cause the workpiece to move upon contact, leading to injury. Use clamps or other devices to prevent movement.
- Loss of control of the tool can lead to injury to self or others. Never use tool while using drugs or alcohol. Don't overreach. Keep proper footing and balance. Keep handles dry, clean and free from oil/grease. Stay alert. Do not operate tool when you are tired.

5. HEALTH AND SAFETY INFORMATION

- Poor quality, improper or damaged tools such as grinding wheels, chisels, sockets, drills, nailers, staplers, etc., can fly apart during operation, propelling particles throughout the work area causing serious injury. Never point discharge of tool at self or others. Do not pull trigger unless tool contact safety device is against work surface. Never attempt to drive fasteners into hard surfaces such as steel, concrete, or tile. Avoid driving a fastener on top of another fastener. Position tool carefully so that fasteners will be delivered to the proper location.
- Improperly maintained tools and accessories can cause serious injury. Maintain the tool with care. Keep a cutting tool sharp and clean. A properly maintained tool, with sharp cutting edges, reduces the risk of binding and is easier to control.
- Use only accessories identified by the manufacturer to be used with specific tools. Use of an accessory not intended for use with the specific tools increase the risk of injury to persons.
- This tool is not provided with an insulated gripping surface. Contact with a “live” wire will also make exposed metal parts of the tool “live” and can result in electrocution or death. Avoid body contact with grounded surfaces such as pipes, radiators, ranges and refrigerators. There is an increased risk of electric shock if your body is grounded.
- Fasteners coming in contact with hidden electrical wiring could cause electrocution or death. Thoroughly investigate the workpiece for possible hidden wiring before performing work.
- Tools that cut, shear, drill, staple, punch, chisel, etc. are capable of causing serious injury. Keep the working part of the tool away from hands and body.

5.4 RESIDUAL RISK

Warning!

- Although the safety instructions and operating manuals for our tools contain extensive instructions of safe working with power tools, every power tool involves a certain residual risk which can not be completely excluded by safety mechanisms. Power tools must therefore always be operated with caution!

6. TECHNICAL DESCRIPTION

6.1 IDENTIFICATION

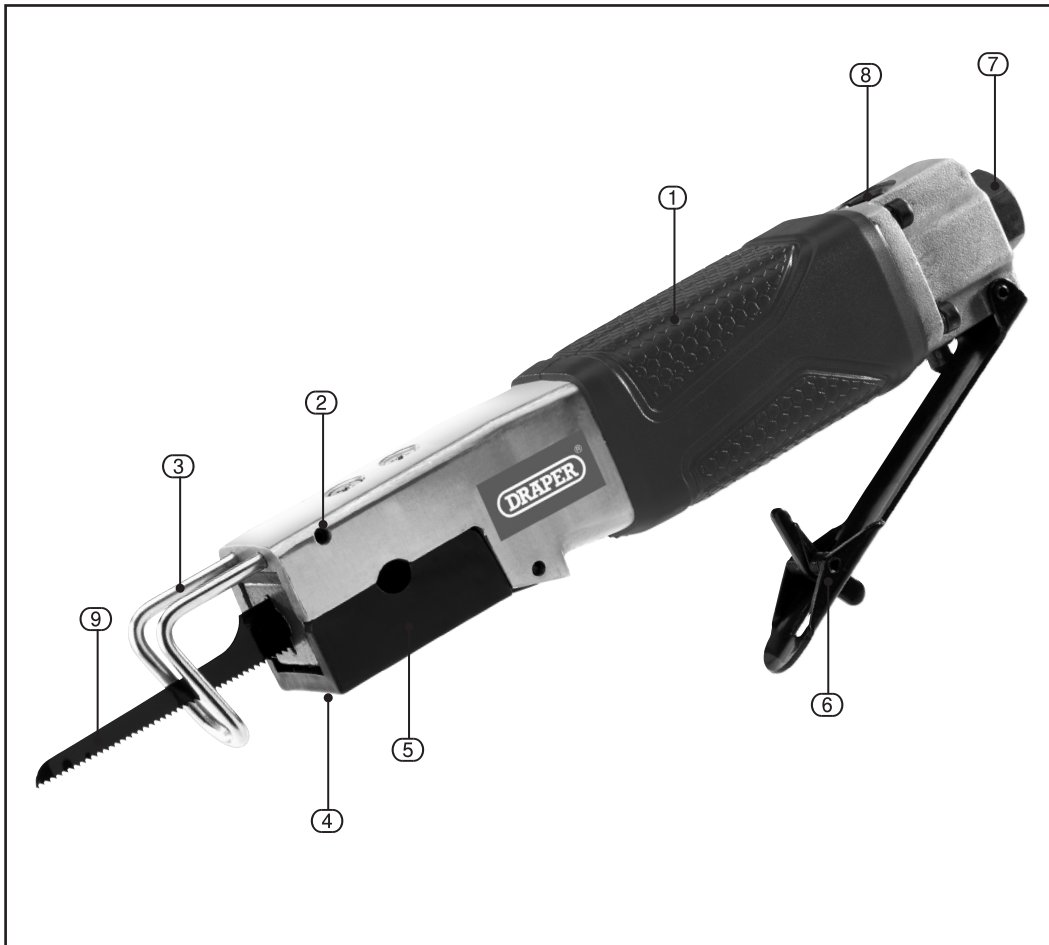

- ① Soft grip.
- ② Work guard adjustment screws.
- ③ Work guard.
- ④ Chuck cover release screw.
- ⑤ Chuck cover.
- ⑥ Trigger.
- ⑦ ¼" BSP air inlet.
- ⑧ Valve speed adjustment screw.

7. UNPACKING AND CHECKING

7.1 PACKAGING

Carefully remove the product from the packaging and examine it for any sign of damage that may have happened during shipping. Lay the contents out and check them against the parts shown below. If any part is damaged or missing; please contact the Draper Helpline (the telephone number appears on the Title page) and do not attempt to use the saw.

The packaging material should be retained at least during the guarantee period: in case the saw needs to be returned for repair.



Warning!

- Some of the packaging materials used may be harmful to children. Do not leave any of these materials in the reach of children.
- If any of the packaging is to be thrown away, make sure they are disposed of correctly; according to local regulations.

7.2 WHAT'S IN THE BOX?

As well as the saw there are parts not fitted or attached to it.

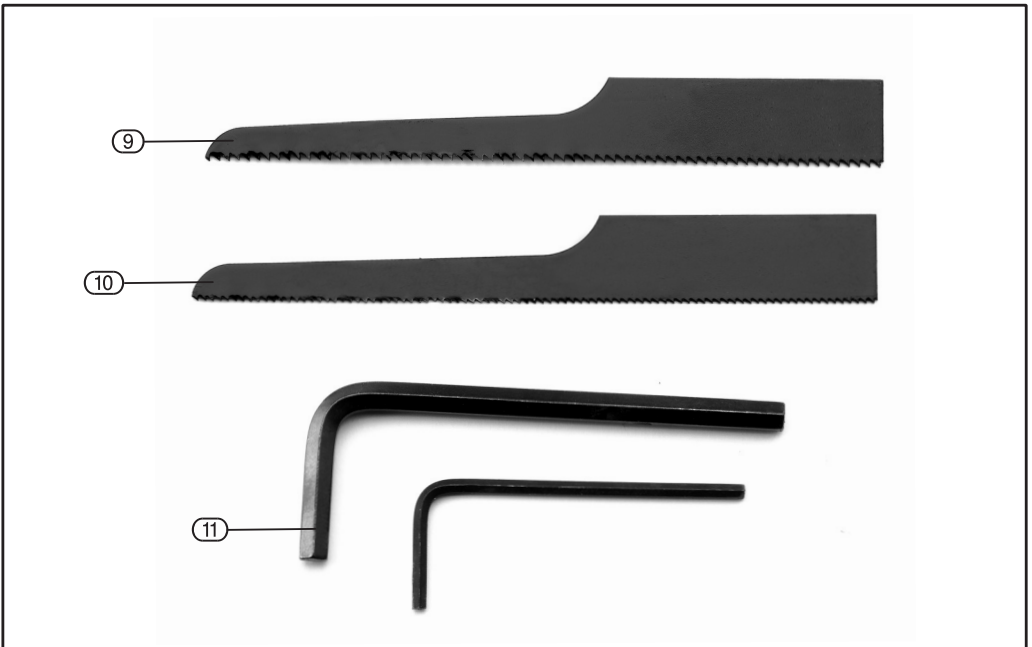

⑨ 18T saw blade.

⑩ 18T saw blade.

⑪ 2x Hex keys.

9. ASSEMBLY



Warning!

- Failure to follow these instructions will lead to premature malfunction of the equipment which is not covered by the guarantee.

NOTE: Disconnect from the air supply before carrying out adjustment, servicing or maintenance.

9.1 CONNECTION TO THE AIR SUPPLY

– FIG. 2

To connect the body saw to an air line, a 1/4" BSP male thread whip hose (12)* will be required.

- Wind a length of PTFE tape (13)** around the thread of the whip hose.
- Attach the hose via the 1/4" BSP (female) air inlet (7). The connection must be tight for an airtight union.

*PTFE tape	Stock No.63389
**1/4" BSP whip hose	Stock No.54438

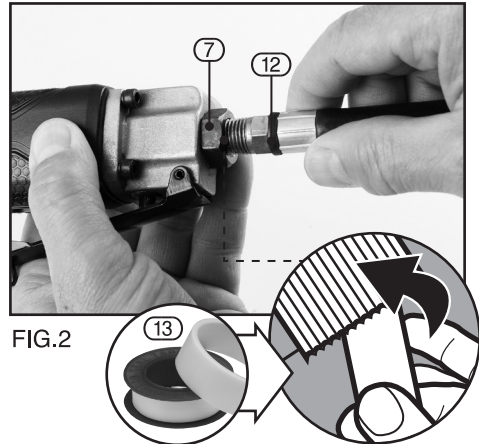

FIG.2

9.2 REPLACEMENT OF SAW BLADE - FIG. 3

- Loosen the chuck cover release screw (4) with a screwdriver (not supplied) allowing you to open the chuck cover (5).
- Loosen the rolling pins both sides using a hex key (supplied).
- Insert a blade.
- Tighten the two rolling pins to fix the blade in place. Make sure that it is secure.
- Replace the chuck cover and tighten the screw.

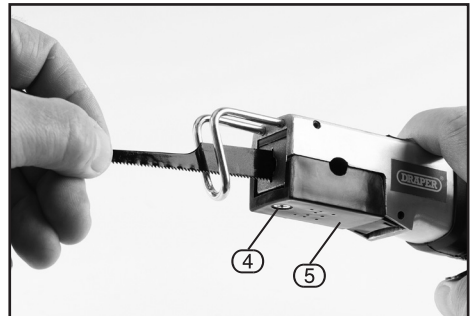

FIG.3

9.3 ADJUSTING THE WORK GUARD - FIG. 4

The work guard functions as a guide for cutting depth. You can control the depth of cut by adjusting the height of work guide as intended.

- Loosen the two work guard adjustment screws (2) on each side using the supplied hex key.
- Pull the work guard to the required depth and retighten screws.

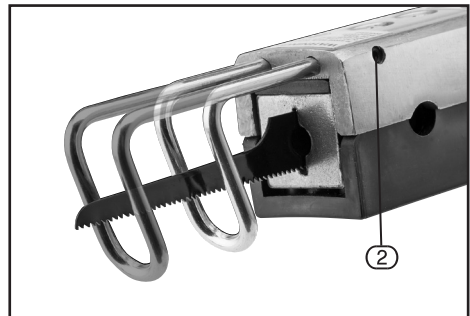

FIG.4

10. OPERATION

10.1 OPERATION - FIG. 5

Push the safety trigger switch and then press the trigger (6).
The tool speed can be adjusted by rotating the valve speed adjustment screw (8) with a screwdriver (not supplied).

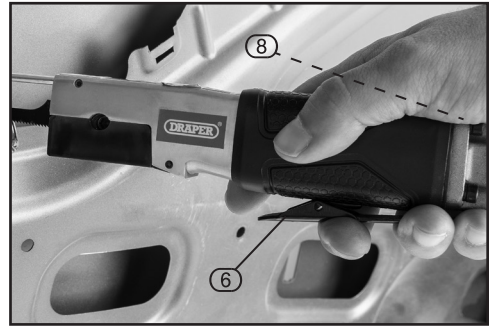

FIG.5

11. MAINTENANCE



Warning!

- Disconnect from the air supply before carrying out any adjustments, servicing or maintenance.
- Never use any sockets or accessories that are not hardened for impact use.

11.1 EVERY-DAY MAINTENANCE CHECKS

Before connection to the air supply:

- Drain the compressor reservoir of condensate.
- Drain the air lines of condensate.
- Drain the combined separator filter, regulator, water trap.
- Fill up the combined separator filter, regulator, lubricant reservoir.
- Check the line pressure is correct for the tool.

11.2 AFTER USE MAINTENANCE CHECKS

- Repeat the above procedures.
- Lubricate the tool with approximately 1.5ml of oil directly down the air inlet.

12. TROUBLESHOOTING

12.1 TROUBLESHOOTING GUIDE

Problems	Possible cause	Required action
Tool runs slowly or will not operate.	<ul style="list-style-type: none"> - Grit or gum in tool. - No oil in tool. - Low air pressure. - Air hose leaks. - Pressure drops. - Moisture blowing out of tool exhaust. 	<ul style="list-style-type: none"> - Flush the tool with air-tool oil or gum solvent. - Lubricate the tool according to the lubrication instructions in this manual. - Adjust the regulator on the tool to maximum setting. Adjust the compressor regulator to tool maximum of 90psi. - Tighten and seal hose fittings if leaks are found. Use sealing tape. - Be sure the hose is the proper size. Long hose or tools using large volumes of air may require a hose with an ID of ½" or larger depending on the total length of the hoses. Do not use multiple number of hoses connected together with quick connect fittings. This causes additional pressure drops and reduces the tool power. Directly connect the hoses together. - Water in tank: drain tank. Oil tool and run until no water is evident. Oil tool again and run for 1-2 seconds.
Abnormal vibration and/or excessive heat develops in the tool.	<ul style="list-style-type: none"> - Improper lubrication 	<ul style="list-style-type: none"> - Follow proper lubrication procedures in this manual.

We recommend the use of Draper Air Tool Oil:	250ml	Stock No.34679
	500ml	Stock No.34681
	1Litre	Stock No.34682

Parts listing for replacement parts is available at www.drapertools.com

13. EXPLANATION OF SYMBOLS

13.1 EXPLANATION OF SYMBOLS



Read the instruction manual.



Wear safety glasses.



Wear ear defenders.



Wear protective gloves.



Long and loose hair must be contained or securely tied back.



Do not abandon into the environment.



Keep out of the reach of children.



Warning!



Warning! Risk of crushing.

14. DISPOSAL



14.1 DISPOSAL

- At the end of the machine's working life, or when it can no longer be repaired, ensure that it is disposed of according to national regulations.
- Contact your local authority for details of collection schemes in your area.

In all circumstances:

- Do not dispose of power tools with domestic waste.
- Do not incinerate.
- During decommissioning of the equipment, certain hazards should be understood and avoided:
 - Only with the line pressure released shall the equipment be disassembled.
 - Goggles should be worn.

CONTACTS

Draper Tools Limited, Hursley Road,
Chandler's Ford, Eastleigh, Hampshire. SO53 1YF. U.K.

Helpline: (023) 8049 4344

Sales Desk: (023) 8049 4333

Internet: drapertools.com

E-mail: sales@drapertools.com

General Enquiries: (023) 8026 6355

Service/Warranty Repair Agent:

For aftersales servicing or warranty repairs, please contact the Draper Tools Helpline for details of an agent in your local area.

YOUR DRAPER STOCKIST

DBC0719

©Published by Draper Tools Limited.

No part of this publication may be reproduced, stored in a retrieval system or transmitted in any form or by any means, electronic, mechanical photocopying, recording or otherwise without prior permission in writing from Draper Tools Ltd.