



230V OIL FREE COMPRESSOR

02116



IMPORTANT: Please read these instructions carefully to ensure the safe and effective use of this product and save these instructions for future reference. This manual has been compiled by Draper Tools and is an integrated part of the product with which it is enclosed and should be kept with it for future references.

This manual describes the purpose for which the product has been designed and contains all the necessary information to ensure its correct and safe use. We recommend that this manual is read before any operation or, before performing any kind of adjustment to the product and prior to any maintenance tasks. By following all the general safety instructions contained in this manual, it will ensure both product and operator safety, together with longer life of the product itself.

All photographs and drawings in this manual are supplied by Draper Tools to help illustrate the operation of the product. Whilst every effort has been made to ensure accuracy of information contained in this manual, the Draper Tools policy of continuous improvement determines the right to make modifications without prior warning.

1. TITLE PAGE

1.1 INTRODUCTION:

USER MANUAL FOR: 230V Oil Free Compressor

Stock No: 02116

Part No: DA6/181

1.2 REVISIONS:

Date first published March 2018.

As our user manuals are continually updated, users should make sure that they use the very latest version.

Downloads are available from: <http://drapertools.com/manuals>

Draper Tools Limited
Hursley Road
Chandler's Ford
Eastleigh
Hampshire
SO53 1YF
UK

Website: drapertools.com

Product Helpline: +44 (0) 23 8049 4344

General Fax: +44 (0) 23 8026 0784

1.3 UNDERSTANDING THIS MANUALS SAFETY CONTENT:

WARNING! – Information that draws attention to the risk of injury or death.

CAUTION! – Information that draws attention to the risk of damage to the product or surroundings.

1.4 COPYRIGHT © NOTICE:

Copyright © Draper Tools Limited.

Permission is granted to reproduce this publication for personal and educational use only. Commercial copying, redistribution, hiring or lending is prohibited.

No part of this publication may be stored in a retrieval system or transmitted in any other form or means without written permission from Draper Tools Limited.

In all cases this copyright notice must remain intact.

2. CONTENTS

1. TITLE PAGE	
1.1 INTRODUCTION.....	2
1.2 REVISION HISTORY	2
1.3 UNDERSTANDING THIS MANUAL	2
1.4 COPYRIGHT NOTICE.....	2
2. CONTENTS	
2.1 CONTENTS	3
3. GUARANTEE	
3.1 GUARANTEE	4
4. INTRODUCTION	
4.1 SCOPE.....	5
4.2 SPECIFICATION	5
4.3 HANDLING AND STORAGE	5
5. HEALTH AND SAFETY INFORMATION	
5.1 GENERAL SAFETY INSTRUCTIONS FOR POWER TOOL USE	6
5.2 ADDITIONAL SAFETY INSTRUCTIONS FOR SAFETY VALVES	7
5.3 ADDITIONAL SAFETY INSTRUCTIONS FOR PRESSURE VESSELS	8
5.4 CONNECTION TO THE POWER SUPPLY.....	9
6. TECHNICAL DESCRIPTION	
6.1 IDENTIFICATION	10
7. UNPACKING AND CHECKING	
7.1 PACKAGING	10
7.2 WHAT'S IN THE BOX?.....	11
8. PREPARING THE COMPRESSOR	
8.1 LOCATION AND ASSEMBLY.....	12
8.2 INITIAL STARTUP.....	12
9. OPERATION	
9.1 BASIC COMPRESSOR OPERATION.....	13
9.2 MOISTURE IN COMPRESSED AIR	13
9.3 SAFETY VALVE	13
9.4 THERMAL OVERLOAD PROTECTOR.....	14
9.5 STORAGE.....	14
10. TROUBLESHOOTING	
10.1 TROUBLESHOOTING GUIDE.....	15
11. MAINTENANCE	
11.1 BASIC MAINTENANCE AND CHECKS	17
11.2 DRAINING MOISTURE FROM THE TANK.....	17
12. EXPLANATION OF SYMBOLS	
12.1 EXPLANATION OF SYMBOLS	18
13. DISPOSAL	
13.1 DISPOSAL.....	19
DECLARATION OF CONFORMITY	ENCLOSED

3. GUARANTEE

3.1 GUARANTEE

Draper tools have been carefully tested and inspected before shipment and are guaranteed to be free from defective materials and workmanship.

Should the tool develop a fault, please return the complete tool to your nearest distributor or contact:

Draper Tools Limited, Chandler's Ford, Eastleigh, Hampshire, SO53 1YF. England.

Telephone Sales Desk: (023) 8049 4333 or:

Product Helpline (023) 8049 4344.

A proof of purchase must be provided.

If upon inspection it is found that the fault occurring is due to defective materials or workmanship, repairs will be carried out free of charge. This guarantee period covering parts/labour is 12 months from the date of purchase except where tools are hired out when the guarantee period is 90 days from the date of purchase. The guarantee is extended to 24 months for parts only. This guarantee does not apply to normal wear and tear, nor does it cover any damage caused by misuse, careless or unsafe handling, alterations, accidents, or repairs attempted or made by any personnel other than the authorised Draper warranty repair agent.

Note: If the tool is found not to be within the terms of warranty, repairs and carriage charges will be quoted and made accordingly.

This guarantee applies in lieu of any other guarantee expressed or implied and variations of its terms are not authorised.

Your Draper guarantee is not effective unless you can produce upon request a dated receipt or invoice to verify your proof of purchase within the guarantee period.

Please note that this guarantee is an additional benefit and does not affect your statutory rights.

Draper Tools Limited.

4. INTRODUCTION

4.1 SCOPE

The compressor in this manual is capable of supplying compressed air to a maximum pressure of 8bar to operate pneumatic tools for a variety of applications including blowing, spraying and tyre inflating.

4.2 SPECIFICATION

Stock no.....	02116
Part no.....	DA6/181
Motor:	
Rated voltage	230V~
Rated frequency	50Hz
Rated input	1200W (1.5HP)
Revolutions per minute (no load)	4,000min ⁻¹
Max. working pressure	116psi (8bar)
Air displacement	6.5cfm (185L/min)
Free air delivery	5.1cfm (145L/min)
Receiver capacity	6L
Sound pressure level.....	85dB(A)
Sound power level	97dB(A)
*Single value noise level	94dB(A)
Dimension (LxWxH).....	410 x 310 x 540mm
Weight	11.5kg

4.3 HANDLING & STORAGE

This compressor is designed to be moved to different locations. Ensure it is always operated on a level surface. When in transit care should be taken not to cause damage particularly to gauges and air lines.

*A-Weighed sound power level in accordance to 2000/14/EC

5. HEALTH & SAFETY INFORMATION

Have this tool repaired by a qualified person. This tool is designed to conform to the relevant international and local standards and as such should be maintained and repaired by someone qualified, using only original parts supplied by the manufacturer. This will ensure the tool remains safe to use.

5.1 GENERAL SAFETY INSTRUCTIONS FOR POWER TOOL USE

Warning: Read all safety warnings and all instructions. Failure to follow the warnings and instructions may result in electric shock, fire and/or serious injury.

Save all warnings and instructions for future reference.

The term “power tool” in the warnings refers to your mains operated (corded) power tool or battery-operated (cordless) power tool.

1) Work area safety

- a) Keep work area clean and well lit. Cluttered or dark areas invite accidents.
- b) Do not operate power tools in explosive atmospheres, such as in the presence of flammable liquids, gases or dust. Power tools create sparks which may ignite the dust or fumes.
- c) Keep children and bystanders away while operating a power tool. Distractions can cause you to lose control.

2) Electrical safety

- a) Power tool plugs must match the outlet. Never modify the plug in any way. Do not use any adapter plugs with earthed (grounded) power tools. Unmodified plugs and matching outlets will reduce risk of electric shock.
- b) Avoid body contact with earthed or grounded surfaces such as pipes, radiators, ranges and refrigerators. There is an increased risk of electric shock if your body is earthed or grounded.
- c) Do not expose power tools to rain or wet conditions. Water entering a power tool will increase the risk of electric shock.
- d) Do not abuse the cord. Never use the cord for carrying, pulling or unplugging the power tool. Keep cord away from heat, oil, sharp edges or moving parts. Damaged or entangled cords increase the risk of electric shock.
- e) When operating a power tool outdoors, use an extension cord suitable for outdoor use. Use of a cord suitable for outdoor use reduces the risk of electric shock.
- f) If operating a power tool in a damp location is unavoidable, use a residual current device (RCD) protected supply. Use of an RCD reduces the risk of electric shock.

3) Personal safety

- a) Stay alert, watch what you are doing and use common sense when operating a power tool. Do not use a power tool while you are tired or under the influence of drugs, alcohol or medication. A moment of inattention while operating power tools may result in serious personal injury.
- b) Use personal protective equipment. Always wear eye protection. Protective equipment such as dust mask, non-skid safety shoes, hard hat, or hearing protection used for appropriate conditions will reduce personal injuries.
- c) Prevent unintentional starting. Ensure the switch is in the off position before connecting to power source and/or battery pack, picking up or carrying the tool. Carrying power tools with your finger on the switch or energising power tools that have the switch on invites accidents.
- d) Remove any adjusting key or wrench before turning the power tool on. A wrench or a key left attached to a rotating part of the power tool may result in personal injury.

5. HEALTH & SAFETY INFORMATION

- e) Do not overreach. Keep proper footing and balance at all times. This enables better control of the power tool in unexpected situations.
- f) Dress properly. Do not wear loose clothing or jewellery. Keep your hair, clothing and gloves away from moving parts. Loose clothes, jewellery or long hair can be caught in moving parts.
- g) If devices are provided for the connection of dust extraction and collection facilities, ensure these are connected and properly used. Use of these devices can reduce dust-related hazards.

4) Power tool use and care

- a) Do not force the power tool. Use the correct power tool for your application. The correct power tool will do the job better and safer at the rate for which it was designed.
- b) Do not use the power tool if the switch does not turn it on and off. Any power tool that cannot be controlled with the switch is dangerous and must be repaired.
- c) Disconnect the plug from the power source and/or battery pack from the power tool before making any adjustments, changing accessories, or storing power tools. Such preventive safety measures reduce the risk of starting the power tool accidentally.
- d) Store idle power tools out of the reach of children and do not allow persons unfamiliar with the power tool or these instructions to operate the power tool. Power tools are dangerous in the hands of untrained users.
- e) Maintain power tools. Check for misalignment or binding of moving parts, breakage of parts and any other condition that may affect the power tool's operation. If damaged, have the power tool repaired before use. Many accidents are caused by poorly maintained power tools.
- f) Keep cutting tools sharp and clean. Properly maintained cutting tools with sharp cutting edges are less likely to bind and are easier to control.
- g) Use the power tool, accessories and tool bits etc. in accordance with these instructions, taking into account the working conditions and the work to be performed. Use of the power tool for operations different from those intended could result in a hazardous situation.

5) Service

- a) Have your power tool serviced by a qualified repair person using only identical replacement parts. This will ensure that the safety of the power tool is maintained.

Important

On products exceeding 2000W it is recommended that the power cable and/or extension cable are fully unwound before a connection is made to the power supply. However, ensure the residual cable does not pose a trip hazard.

5.2 ADDITIONAL SAFETY INSTRUCTIONS FOR SAFETY VALVES

Information: The safety valves are designed and constructed for use exclusively with compressed air, free from impurities. The materials used in construction are suitable for operating the valve at the rated pressure and temperatures. The Viton or NBR gasket conserves the resistance characteristics, even in prolonged use. The valve caulking impedes calibration modification; tampering with the valve and/or changing the constructor's calibration is forbidden.

Installation: Valve installation must be performed exclusively by technically prepared persons, who are responsible and in good health. Checking the integrity of the valve before installation is obligatory. Also, check that the valve pressure is no greater than the operating pressure of the tank or of the system to protect.

5. HEALTH & SAFETY INFORMATION

Check that the discharge flow rate of the valve is greater than the quantity of the air to discharge. The safety valve must be positioned directly on the tank in a vertical position, in a dry, accessible place protected against the weather and far away from liquids or condensation.

It must be positioned so as to have sufficient space all around for correct air discharge, without causing damage to persons and/or things. The valve rod must therefore be free in its movement when discharging.

The connection between the valve and the part to be protected must be free from all kinds of choking and be as short as possible so as not to reduce the discharge flow rate of the valve itself. The connection passage area must be greater than the valve orifice area. During installation, screw on the valve with a torque spanner using the hexagonal part of the body. Apply a maximum torque of 30Nm, paying attention not to cause any deformation; using pincers, pliers, hammers or tools other than a hexagonal spanner is forbidden. Check the inlet hole and the shutter are not blocked by glue, Teflon or similar materials that could bind the shutter or other functional components. If the valve is replaced, the compressor air contained in the system must be discharged first. We decline all responsibility for damage caused to persons and/or things due to failure to observe these instructions.

Maintenance and inspection: The valve must not be subject to knocks which may cause deformities. It is obligatory for qualified technicians to make sure that the safety valve functions correctly at least once a year. Valves equipped with a ring must be tested while pressurised to between 80 – 90% of the calibration value. Pull the ring and release immediately. During the test the valve must definitely open and discharge the air and re-close immediately when the ring is released. It is absolutely necessary to carry out this procedure with the utmost caution because this type of job can be dangerous if adequate safety measures are not taken; wear goggles, a head set and anything else necessary to protect against noise, jets of air, etc. which may be discharged from the valve.

5.3 ADDITIONAL SAFETY INSTRUCTIONS FOR PRESSURE VESSELS

- This pressure tank is mainly intended for static use. It can only be charged with natural air within temperature and pressure limits as specified on the manufacturer's plate and declaration of conformity.
- Ensure that tank safety and control devices are efficient and flawless. When replaced, the tank should not be under pressure.
- Drain the condensation off the tank every day.
- Check for signs of inner corrosion at regular intervals. Tank walls should have a minimum thickness of 1.0 – 2.0mm.
- Any kind of welding to the tank is forbidden.
- The user shall comply with laws on pressure vessel operation in force in the country in which the tank is operated.
- The construction is mainly effected for permanent load by internal pressure. Cyclic loads are not considered, only for a range of 10% PS.

5. HEALTH & SAFETY INFORMATION

5.4 CONNECTION TO THE POWER SUPPLY

Make sure the power supply information on the machine's rating plate are compatible with the power supply you intend to connect it to.

This compressor comes supplied with a UK standard 3 pin plug fitted. It is designed for connection to a domestic power supply rated at 230V AC.

Because it is constructed mostly of metal parts, it is a Class 1 machine; meaning, it must have an earth connection in the power supply. This is to prevent electrocution in the event of a failure.

Apart from replacing the fuse in the plug, no other electrical work is recommended on this compressor.

6. TECHNICAL DESCRIPTION

6.1 IDENTIFICATION



- ① Carry handle.
- ② ON/OFF button.
- ③ Pressure regulator.
- ④ Euro connector.
- ⑤ Tank Pressure gauge.
- ⑥ Air outlet pressure gauge.
- ⑦ Safety valve.
- ⑧ 2 × Transport wheels.
- ⑨ Power supply cable.
- ⑩ Power supply cable storage hooks.
- ⑪ Extending transport handle.
- ⑫ Air outlet.
- ⑬ Drain cock.
- ⑭ Accessory drawer.

7. UNPACKING & CHECKING

7.1 PACKAGING

Carefully remove the product from the packaging and examine it for any sign of damage caused during shipping. Lay the contents out and check them. If any part is damaged or missing, do not attempt to use the tool and contact the Draper Helpline immediately (see back page for details).

Retain the packaging material at least during the guarantee period: in case the machine needs to be returned for repair.

Warning! Some of the packaging materials used may be harmful to children, keep them out of reach from children.

Disposed of any packaging correctly and according to local regulations.

7.2 WHAT'S IN THE BOX?

As well as the product; there are several parts not fitted or attached to it.

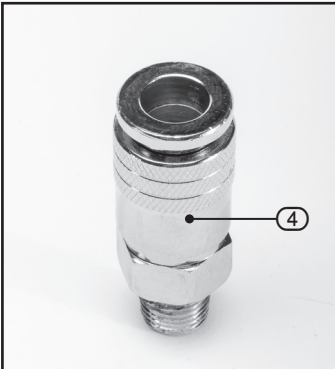

④ Euro connector.

8. PREPARING THE COMPRESSOR

Note: Remove the plug from the socket before carrying out adjustment, servicing or maintenance.

8.1 LOCATION AND ASSEMBLY – FIG. 1

It is extremely important to install the compressor in a clean, well ventilated area where the surrounding air temperature will not be more than 40°C. A minimum clearance of 500mm between the compressor and a wall is required.

In addition to pneumatic air tools, your compressor may be connected to several accessories suitable for blowing, washing and spraying. For technical specifications and detailed instructions, please refer to the instructions provided for the individual accessory.

1. Using a suitable spanner (not supplied) screw the air outlet quick connector (4) onto the air outlet (12); A small amount of PTFE tape may be required on the threads to prevent air leaks. Then turn the pressure regulator clockwise (3) to fully open.

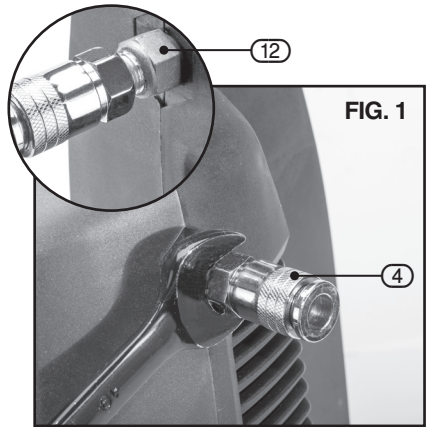

8.2 INITIAL STARTUP – FIG. 2

1. Insert a loose euro coupling into the euro connector (see 9.1).
2. Switch the ON/OFF button (2) to the “ON” position to start the compressor.
3. Run the compressor for 30 minutes allowing the pressure to escape.
4. Turn the pressure regulator fully counter-clockwise allowing pressure to build up. Once the maximum pressure is reached, the pressure switch will automatically turn the machine off.
5. Turn the compressor off, by pressing the ON/OFF button to “OFF” position and open the regulator valve allowing the air to escape.

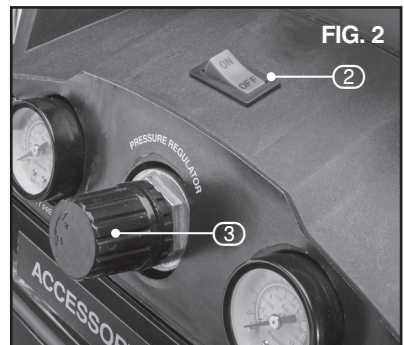

9. OPERATION

9.1 BASIC COMPRESSOR OPERATION – FIG. 3

1. Connect the air line to the compressor by pulling back the collar (4.1) on the air outlet quick coupling (4) and inserting the corresponding air coupling fitted on the air line. Release the collar so it slides back in place to secure the air coupling.
2. Turn the air regulator (3) clockwise to its lowest setting and turn on the compressor.
3. Once the compressor has reached maximum pressure, open the regulator valve (3) to the desired pressure on the tank pressure gauge (5).

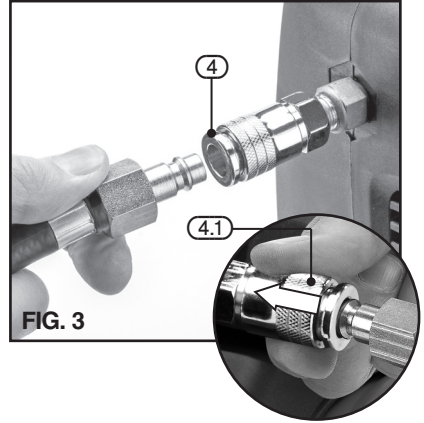

9.2 MOISTURE IN COMPRESSED AIR

Moisture in compressed air will form into droplets as it comes from an air compressor pump. When humidity is high or when a compressor is in continuous use for an extended period of time, this moisture will collect in the tank. When using a paint spray gun or sandblast gun, this water will be carried from the tank through the hose, and out of the gun as droplets mixed with the spray material.

IMPORTANT: This condensation will cause water spots in a paint job, especially when spraying other than water based paints. If sandblasting, it will cause the sand to case and clog the gun rendering it ineffective. A filter in the air line, located as near to the gun as possible, will help eliminate this moisture.

9.3 SAFETY VALVE – FIG. 4

WARNING: DO NOT REMOVE OR ATTEMPT TO ADJUST THE SAFETY VALVE!

This valve (7) should be checked under pressure occasionally by pulling the ring (7.1) by hand. If air leaks after the ring has been released, or valve is stuck, it **MUST** be replaced.

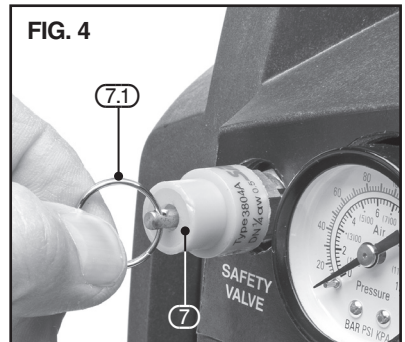

9. OPERATION

9.4 THERMAL OVERLOAD PROTECTOR

CAUTION: THIS COMPRESSOR IS EQUIPPED WITH AN AUTOMATIC RESET THERMAL OVERLOAD PROTECTOR, WHICH WILL SHUT OFF THE MOTOR IF IT BECOMES OVERHEATED.

If thermal overload protector shuts motor OFF frequently, look for the following causes.

- Low voltage.
- Clogged air filter.
- Lack of proper ventilation.

CAUTION: IF THE THERMAL OVERLOAD PROTECTOR IS ACTUATED, THE MOTOR MUST BE ALLOWED TO COOL DOWN BEFORE START-UP IS POSSIBLE. THE MOTOR WILL AUTOMATICALLY RESTART WITHOUT WARNING IF LEFT PLUGGED INTO ELECTRICAL OUTLET AND UNIT IS TURNED ON.

9.5 STORAGE

- When not in use, store hose and compressor in a cool dry place.
- Drain tank of moisture.
- Disconnect hose and hang open ends down to allow any moisture to drain.

10. TROUBLESHOOTING

10.1 TROUBLESHOOTING GUIDE

FAULT	POSSIBLE CAUSE	REMEDY
Compressor will not run.	<ol style="list-style-type: none"> 1. No electrical power. 2. Blown fuse. 3. Breaker open. 4. Thermal overload open. 5. Pressure switch bad. 	<ol style="list-style-type: none"> 1. Plugged in? Check fuse/breaker or motor overload. 2. Replace blown fuse. 3. Reset, determine cause of problem. 4. Motor will restart when cool. 5. Service/repair/replace.
Motor operating, but cannot run or runs slowly.	<ol style="list-style-type: none"> 1. Defective check valve or unloaded. 2. Poor contacts, line voltage low. 3. Shortened or open motor winding. 	<ol style="list-style-type: none"> 1. Service/repair/replace. 2. Check circuit with voltmeter. 3. Service/repair/replace.
Fuses blow/circuit breaker trips repeatedly. Caution! Never use an extension cord with this product.	<ol style="list-style-type: none"> 1. Incorrect size fuse, circuit overloaded. 2. Defective check valve or unloaded. 	<ol style="list-style-type: none"> 1. Check for proper fuse, use time-delay fuse. Disconnect other electrical appliances from circuit or operate compressor on its own branch circuit. 2. Service/repair/replace.
Thermal overload protector cuts out repeatedly.	<ol style="list-style-type: none"> 1. Lack of proper ventilation/room temperature too high. 2. Compressor valves failed. 3. Low voltage. 	<ol style="list-style-type: none"> 1. Move compressor to well ventilated area. 2. Service/repair/replace. 3. Check circuit with voltmeter.
Knocks, rattles, excessive vibration.	<ol style="list-style-type: none"> 1. Cylinder or piston ring is worn or scored. 	<ol style="list-style-type: none"> 1. Service/repair/replace.
Tank pressure drops when compressor shuts off.	<ol style="list-style-type: none"> 1. Check valve leaking. 2. Loose connections at pressure switch or regulator. 	<ol style="list-style-type: none"> 1. Service/repair/replace. 2. Service/repair/replace.
Compressor runs continuously and air output is lower than normal/low discharge pressure.	<ol style="list-style-type: none"> 1. Excessive air usage, compressor too small. 2. Clogged intake filter. 3. Air leaks in piping (on machine or in outside system). 4. Broken inlet valves. 5. Piston ring worn. 	<ol style="list-style-type: none"> 1. Decrease usage or purchase unit with higher air delivery (SCFM). 2. Service or replace. 3. Replace leaking components or tighten as necessary. 4. Service/repair/replace. 5. Service/repair/replace.

10. TROUBLESHOOTING

FAULT	POSSIBLE CAUSE	REMEDY
Excessive moisture in discharge air.	<ol style="list-style-type: none">1. Excessive water in tank.2. High humidity.	<ol style="list-style-type: none">1. Drain tank.2. Move to area of less humidity; use air line filter. <p>Note: Water condensation is not caused by compressor malfunction.</p>
Compressor runs continuously and safety valve opens as pressure rises.	<ol style="list-style-type: none">1. Defective pressure switch.2. Defective safety valve.	<ol style="list-style-type: none">1. Service/repair/replace.2. Service/repair/replace.
Excessive starting and stopping (auto start).	Excessive condensation in tank	Drain tank more often.
Air leaking from unloader on pressure switch.	Check valve stuck in an open position.	Service/repair/replace.

11. MAINTENANCE

11.1 BASIC MAINTENANCE AND CHECKS

Note: Remove the plug from the socket before carrying out adjustment, servicing or maintenance.

In order to maintain the compressor to its optimum, periodical service checks must be carried out routinely. Allowances should be made to adjust the time scale for machines in occasional service with the exception of the safety valve which must be inspected by a qualified service agent every 12 months regardless of use.

Note: Where necessary, ear defenders and safety goggles must be worn.

Daily checks:

- Before every use check the airline/regulator/seperator.
- After every use adjust the line pressure back to zero.

11.2 DRAINING MOISTURE FROM THE TANK – FIG. 5

The drain cock (13) is located on the underside of the compressor. Use this valve to drain moisture from the tank daily to reduce the risk of corrosion.

- Reduce the tank pressure below 10psi.
- Drain moisture from the tank by opening the drain cock located underneath the tank.

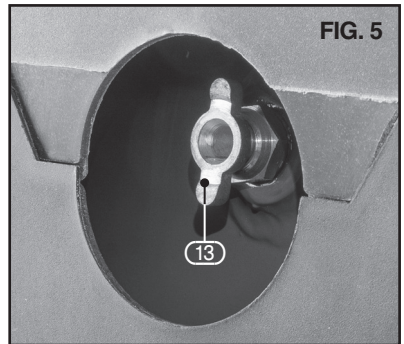

12. EXPLANATION OF SYMBOLS

12.1 EXPLANATION OF SYMBOLS



Warning!
Wear goggles.



Warning!
Wear ear defenders.



Warning!
Read instruction manuals before
operating and servicing this
equipment.



WEEE
Do not dispose of Waste Electrical
& Electronic Equipment in with
domestic rubbish



For indoor use.
Do not expose to rain.



Conforms to all relevant
safety standards.



Warning! Hot surface.



Warning! Compressor unit
may start without warning.



Warning! Risk of electric shock.



Do not open the drain cock before
the air hose is attached.

13. DISPOSAL

13.1 DISPOSAL

- At the end of the machine's working life, or when it can no longer be repaired, ensure that it is disposed of according to national regulations.
- Contact your local authority for details of collection schemes in your area.

In all circumstances:

- Do not dispose of power tools with domestic waste.
- Do not incinerate.
- Do not abandon in the environment.
- Do not dispose of WEEE* as unsorted municipal waste.



* Waste Electrical & Electronic Equipment.

CONTACT US

Draper Tools Limited, Hursley Road,
Chandler's Ford, Eastleigh, Hampshire. SO53 1YF. U.K.

Helpline: +44 (0) 23 8049 4344

Sales Desk: +44 (0) 23 8049 4333

Internet: www.drapertools.com

E-mail: sales@drapertools.com

General Enquiries: (023) 8026 6355

Service/Warranty Repair Agent:

For aftersales servicing or warranty repairs, please contact the Draper Tools Helpline for details of an agent in your local area.

YOUR DRAPER STOCKIST

RWJB0318

©Published by Draper Tools Limited.

No part of this publication may be reproduced, stored in a retrieval system or transmitted in any form or by any means, electronic, mechanical photocopying, recording or otherwise without prior permission in writing from Draper Tools Ltd.