

Owner's Manual



LAWN TRACTOR

20.0 HP, 42" Mower

Electric Start

6 Speed Transaxle

Model No.

917.273471

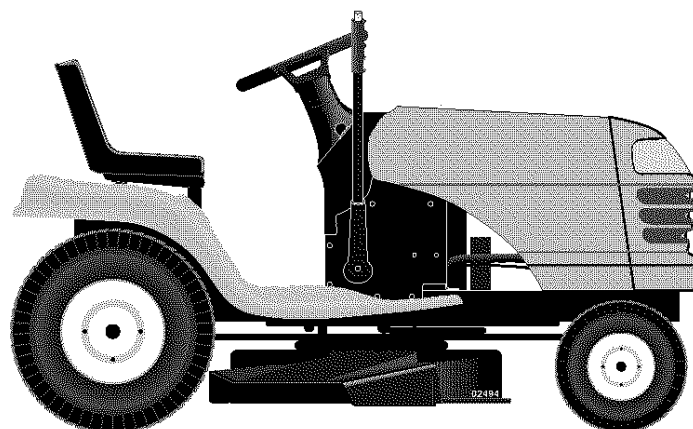

This product has a low emission engine which operates differently from previously built engines. Before you start the engine, read and understand this Owner's Manual.

IMPORTANT:

Read and follow all Safety Rules and Instructions before operating this equipment.

For answers to your questions about this product, Call:

1-800-659-5917

Sears Craftsman Help Line
5 am - 5 pm, Mon - Sat

Sears, Roebuck and Co., Hoffman Estates, IL 60179 U.S.A.

Visit our Craftsman website: www.sears.com/craftsman

TABLE OF CONTENTS

Warranty	2	Maintenance	17
Safety Rules	3	Service and Adjustments.....	21
Product Specifications.....	6	Storage	27
Assembly/Pre-Operation	8	Troubleshooting	28
Operation.....	11	Repair Parts.....	32
Maintenance Schedule.....	17	Sears Service	Back Cover

WARRANTY

LIMITED WARRANTY ON CRAFTSMAN RIDING EQUIPMENT

For two (2) years from the date of purchase, if this Craftsman Riding Equipment is maintained, lubricated and tuned up according to the instructions in the owner's manual, Sears will repair or replace free of charge any parts that are found to be defective in material or workmanship according to the guidelines of coverage listed below. Sears will also provide free labor for these applicable warranted parts for the two full years. During the first 30 days of purchase, there will be no charges to service the product at your home for issues covered by this warranty. (See exclusions below). For your convenience, IN HOME warranty service will still be available after the first 30 days of purchase, but a trip charge will apply. This charge will be waived if the Craftsman product is dropped off at an authorized Sears location. For the nearest authorized Sears location, please call 1-800-4-MY-HOME®. This warranty applies only while this product is within the United States.

This Warranty does not cover:

- Expendable items which become worn during normal use, including but not limited to blades, spark plugs, air cleaners, belts, and oil filters.
- Standard Maintenance Servicing, oil changes, or tune-ups
- Tire replacement or repair caused by punctures from outside objects, such as nails, thorns, stumps, or glass.
- Repairs necessary because of operator abuse, including but not limited to, damage caused by towing objects beyond the capability of the riding equipment, impacting objects that bend the frame or crankshaft, or over-speeding the engine.
- Repairs necessary because of operator negligence, including but not limited to, electrical and mechanical damage caused by improper storage, failure to use the proper grade and amount of engine oil, failure to keep the deck clear of flammable debris, or failure to maintain the equipment according to the instructions contained in the owner's manual.
- Engine (fuel system) cleaning or repairs caused by fuel determined to be contaminated or oxidized (stale). In general, fuel should be used within 30 days of its purchase date.
- Normal deterioration and wear of the exterior finishes, or product label replacement.
- Riding equipment used for commercial or rental purposes.

LIMITED WARRANTY ON BATTERY

For ninety (90) days from date of purchase, if any battery included with this riding equipment proves defective in material or workmanship and our testing determines the battery will not hold a charge, Sears will replace the battery at no charge. During the first 30 days of purchase, there will be no charges to replace the battery at your HOME. After the first 30 days, for your convenience, IN-HOME warranty service will still be available but a trip charge will apply. This charge will be waived if the Craftsman product is dropped off at an authorized Sears location. For the nearest authorized Sears location, please call 1-800-4-MY-HOME®.

This battery warranty applies only while this product is within the United States.

This warranty gives you specific legal rights, and you may also have other rights, which vary, from state to state.

Sears, Roebuck and Co., Dept. 817WA, Hoffman Estates, IL 60179

SAFETY RULES

IMPORTANT: This cutting machine is capable of amputating hands and feet and throwing objects. Failure to observe the following safety instructions could result in serious injury or death.

⚠ WARNING: In order to prevent accidental starting when setting up, transporting, adjusting or making repairs, always disconnect spark plug wire and place wire where it cannot contact spark plug.

⚠ WARNING: Do not coast down a hill in neutral, you may lose control of the tractor.

⚠ WARNING: Tow only the attachments that are recommended by and comply with specifications of the manufacturer of your tractor. Use common sense when towing. Operate only at the lowest possible speed when on a slope. Too heavy of a load, while on a slope, is dangerous. Tires can lose traction with the ground and cause you to lose control of your tractor.

⚠ WARNING: Engine exhaust, some of its constituents, and certain vehicle components contain or emit chemicals known to the State of California to cause cancer and birth defects or other reproductive harm.

⚠ WARNING: Battery posts, terminals and related accessories contain lead and lead compounds, chemicals known to the State of California to cause cancer and birth defects or other reproductive harm.

Wash hands after handling.

I. GENERAL OPERATION

- Read, understand, and follow all instructions in the manual and on the machine before starting.
- Only allow responsible adults, who are familiar with the instructions, to operate the machine.
- Clear the area of objects such as rocks, toys, wire, etc., which could be picked up and thrown by the blade.
- Be sure the area is clear of other people before mowing. Stop machine if anyone enters the area.
- Never carry passengers.
- Do not mow in reverse unless absolutely necessary. Always look down and behind before and while backing.

- Be aware of the mower discharge direction and do not point it at anyone. Do not operate the mower without either the entire grass catcher or the guard in place.
- Slow down before turning.
- Never leave a running machine unattended. Always turn off blades, set parking brake, stop engine, and remove keys before dismounting.
- Turn off blades when not mowing.
- Stop engine before removing grass catcher or unclogging chute.
- Mow only in daylight or good artificial light.
- Do not operate the machine while under the influence of alcohol or drugs.
- Watch for traffic when operating near or crossing roadways.
- Use extra care when loading or unloading the machine into a trailer or truck.
- Data indicates that operators, age 60 years and above, are involved in a large percentage of riding mower-related injuries. These operators should evaluate their ability to operate the riding mower safely enough to protect themselves and others from serious injury.
- Keep machine free of grass, leaves or other debris build-up which can touch hot exhaust / engine parts and burn. Do not allow the mower deck to plow leaves or other debris which can cause build-up to occur. Clean any oil or fuel spillage before operating or storing the machine. Allow machine to cool before storage.

II. SLOPE OPERATION

Slopes are a major factor related to loss-of-control and tipover accidents, which can result in severe injury or death. All slopes require extra caution. If you cannot back up the slope or if you feel uneasy on it, do not mow it.

SAFETY RULES

DO:

- Mow up and down slopes, not across.
- Remove obstacles such as rocks, tree limbs, etc.
- Watch for holes, ruts, or bumps. Uneven terrain could overturn the machine. *Tall grass can hide obstacles.*
- Use slow speed. Choose a low gear so that you will not have to stop or shift while on the slope.
- Follow the manufacturer's recommendations for wheel weights or counterweights to improve stability.
- Use extra care with grass catchers or other attachments. These can change the stability of the machine.
- Keep all movement on the slopes *slow* and *gradual*. Do not make sudden changes in speed or direction.
- Avoid starting or stopping on a slope. If tires lose traction, disengage the blades and proceed slowly *straight* down the slope.

DO NOT:

- *Do not* turn on slopes unless necessary, and then, turn slowly and gradually downhill, if possible.
- *Do not* mow near drop-offs, ditches, or embankments. The mower could suddenly turn over if a wheel is over the edge of a cliff or ditch, or if an edge caves in.
- *Do not* mow on wet grass. Reduced traction could cause sliding.
- *Do not* try to stabilize the machine by putting your foot on the ground.
- *Do not* use grass catcher on steep slopes.

III. CHILDREN

Tragic accidents can occur if the operator is not alert to the presence of children. Children are often attracted to the machine and the mowing activity. *Never* assume that children will remain where you last saw them.

- Keep children out of the mowing area and under the watchful care of another responsible adult.
- Be alert and turn machine off if children enter the area.
- Before and when backing, look behind and *down* for small children.

- Never carry children. They may fall off and be seriously injured or interfere with safe machine operation.
- Never allow children to operate the machine.
- Use extra care when approaching blind corners, shrubs, trees, or other objects that may obscure vision.

IV. SERVICE

- Use extra care in handling gasoline and other fuels. They are flammable and vapors are explosive.
 - Use only an approved container.
 - Never remove gas cap or add fuel with the engine running. Allow engine to cool before refueling. Do not smoke.
 - Never refuel the machine indoors.
 - Never store the machine or fuel container inside where there is an open flame, such as a water heater.
- Never run a machine inside a closed area.
- Keep nuts and bolts, especially blade attachment bolts, tight and keep equipment in good condition.
- Never tamper with safety devices. Check their proper operation regularly.
- Keep machine free of grass, leaves, or other debris build-up. Clean oil or fuel spillage. Allow machine to cool before storing.
- Stop and inspect the equipment if you strike an object. Repair, if necessary, before restarting.
- Never make adjustments or repairs with the engine running.
- Grass catcher components are subject to wear, damage, and deterioration, which could expose moving parts or allow objects to be thrown. Frequently check components and replace with manufacturer's recommended parts, when necessary.
- Mower blades are sharp and can cut. Wrap the blade(s) or wear gloves, and use extra caution when servicing them.
- Check brake operation frequently. Adjust and service as required.

SAFETY RULES

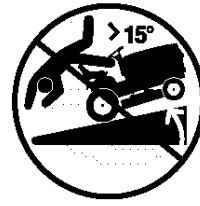

- Be sure the area is clear of other people before mowing. Stop machine if anyone enters the area.
- Never carry passengers or children even with the blades off.
- Do not mow in reverse unless absolutely necessary. Always look down and behind before and while backing.
- Never carry children. They may fall off and be seriously injured or interfere with safe machine operation.
- Keep children out of the mowing area and under the watchful care of another responsible adult.
- Be alert and turn machine off if children enter the area.
- Before and when backing, look behind and down for small children.
- Mow up and down slopes (15° Max), not across.
- Remove obstacles such as rocks, tree limbs, etc.
- Watch for holes, ruts, or bumps. Uneven terrain could overturn the machine. Tall grass can hide obstacles.
- Use slow speed. Choose a low gear so that you will not have to stop or shift while on the slope.
- Avoid starting or stopping on a slope. If tires lose traction, disengage the blades and proceed slowly straight down the slope.
- If machine stops while going uphill, disengage blades, shift into reverse and back down slowly.
- Do not turn on slopes unless necessary, and then, turn slowly and gradually downhill, if possible.

PRODUCT SPECIFICATIONS

Gasoline Capacity and Type:	4.0 Unleaded and Regular
Oil Type (API-SF-SJ):	SAE 10W30 (above 32°F) SAE 5W-30(below 32°F)
Oil Capacity:	W/Filter: 4.0 Pints W/O Filter: 3.5 Pints
Spark Plug: (Gap: .030")	Champion RC12YC
Ground Speed (MPH):	Forward: 1st 1.2 2nd 1.5 3rd 2.4 4th 3.5 5th 4.8 6th 5.3 Reverse: 1.5
Tire Pressure:	Front: 14 PSI Rear: 10 PSI
Charging System:	15 Amps @ 3600RPM
Battery:	Amp/Hr: 35 Min. CCA: 280 Case Size: U1R
Blade Bolt Torque:	27-35 Ft. Lbs.

CONGRATULATIONS on your purchase of a new tractor. It has been designed, engineered and manufactured to give you the best possible dependability and performance.

Should you experience any problem you cannot easily remedy, please contact a Sears or other qualified service center. We have competent, well-trained technicians and the proper tools to service or repair this tractor.

Please read and retain this manual. The instructions will enable you to assemble and maintain your tractor properly. Always observe the "SAFETY RULES".

CUSTOMER RESPONSIBILITIES

- Read and observe the safety rules.
- Follow a regular schedule in maintaining, caring for and using your tractor.
- Follow the instructions under "Maintenance" and "Storage" sections of this owner's manual.

⚠ WARNING: This tractor is equipped with an internal combustion engine and should not be used on or near any unimproved forest-covered, brush-covered or grass-covered land unless the engine's exhaust system is equipped with a spark arrester meeting applicable local or state laws (if any). If a spark arrester is used, it

should be maintained in effective working order by the operator.

In the state of California the above is required by law (Section 4442 of the California Public Resources Code). Other states may have similar laws. Federal laws apply on federal lands. A spark arrester for the muffler is available through your nearest Sears service center (See REPAIR PARTS section of this manual).

REPAIR PROTECTION AGREEMENTS

Congratulations on making a smart purchase. Your new Craftsman® product is designed and manufactured for years of dependable operation. But like all products, it may require repair from time to time. That's when having a Repair Protection Agreement can save you money and aggravation.

Purchase a Repair Protection Agreement now and protect yourself from unexpected hassle and expense.

Here's what's included in the Agreement:

- Expert service by our 12,000 professional repair specialists.
- Unlimited service and no charge for parts and labor on all covered repairs.
- Product replacement if your covered product can't be fixed.
- Discount of 10% from regular price of service and service-related parts not covered by the agreement; also, 10% off regular price of preventive maintenance check.
- Fast help by phone – phone support from a Sears technician on products requiring in-home repair, plus convenient repair scheduling.

Once you purchase the Agreement, a simple phone call is all that it takes for you to schedule service. You can call anytime day or night, or schedule a service appointment online.

Sears has over 12,000 professional repair specialists, who have access to over 4.5 million quality parts and accessories.

That's the kind of professionalism you can count on to help prolong the life of your new purchase for years to come. Purchase your Repair Protection Agreement today!

Some limitations and exclusions apply. For prices and additional information call 1-800-827-6655.

SEARS INSTALLATION SERVICE

For Sears professional installation of home appliances, garage door openers, water heaters, and other major home items, in the U.S.A. call 1-800-4-MY-HOME®

UNASSEMBLED PARTS

Steering Wheel

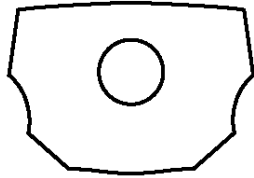

Steering Wheel Insert

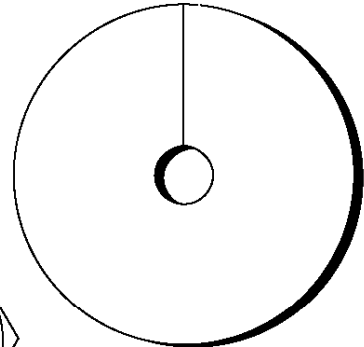
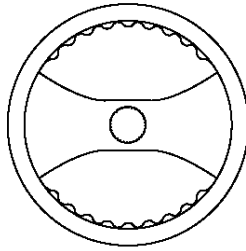

(1) Large Flat Washer



(1) Hex Bolt 1/4-28 x 1-1/4

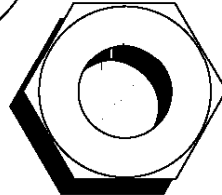

(1) Locknut 1/2-20



(1) Locknut 1/4-28

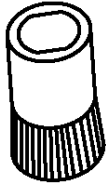

Steering Wheel Adapter

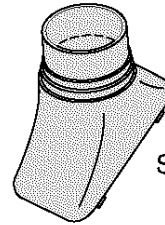

Steering Boot

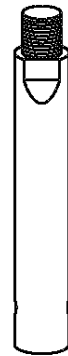

Steering Extension Shaft

Seat

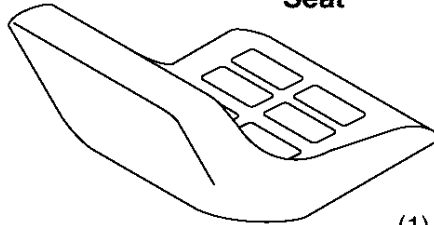

(1) Washer
17/32 x 1-3/16 x 12 Gauge



(1) Knob

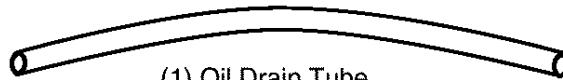

(1) Oil Drain Tube
For Future Use

Keys

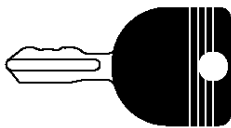

(2) Keys

Slope Sheet

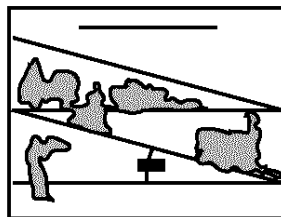

Video Cassette

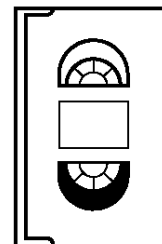

ASSEMBLY/PRE-OPERATION

Your new tractor has been assembled at the factory with the exception of those parts left unassembled for shipping purposes. To ensure safe and proper operation of your tractor all parts and hardware you assemble must be tightened securely. Use the correct tools as necessary to insure proper tightness. Review the video cassette before you begin.

TOOLS REQUIRED FOR ASSEMBLY

A socket wrench set will make assembly easier. Standard wrench sizes you need are listed below.

- (1) 3/4" wrench (1) Pliers
- (2) 7/16" wrench (1) Utility knife
- (1) Tire pressure gauge

When right or left hand is mentioned in this manual, it means when you are in the operating position (seated behind the steering wheel).

TO REMOVE TRACTOR FROM CARTON

UNPACK CARTON

1. Remove all accessible loose parts and parts boxes from carton.
2. Cut along dotted lines on all four panels of carton. Remove end panels and lay side panels flat.
3. Check for any additional loose parts or cartons and remove.

BEFORE REMOVING TRACTOR FROM SKID

ATTACH STEERING WHEEL

ASSEMBLE EXTENSION SHAFT AND BOOT

1. Slide extension shaft onto lower steering shaft. Align mounting holes in extension and lower shafts and install 1/4 hex bolt and locknut. Tighten securely.

IMPORTANT: Tighten bolt and nut securely to 10-12 ft. lbs torque.

2. Place tabs of steering boot over tab slots in dash and push down to secure.

INSTALL STEERING WHEEL

3. Position front wheels of the tractor so they are pointing straight forward.
4. Remove steering wheel adapter from steering wheel and slide adapter onto steering shaft extension.
5. Position steering wheel so cross bars are horizontal (left to right) and slide inside boot and onto adapter.
6. Assemble large flat washer, 1/2 hex nut and tighten securely.
7. Snap steering wheel insert into center of steering wheel.

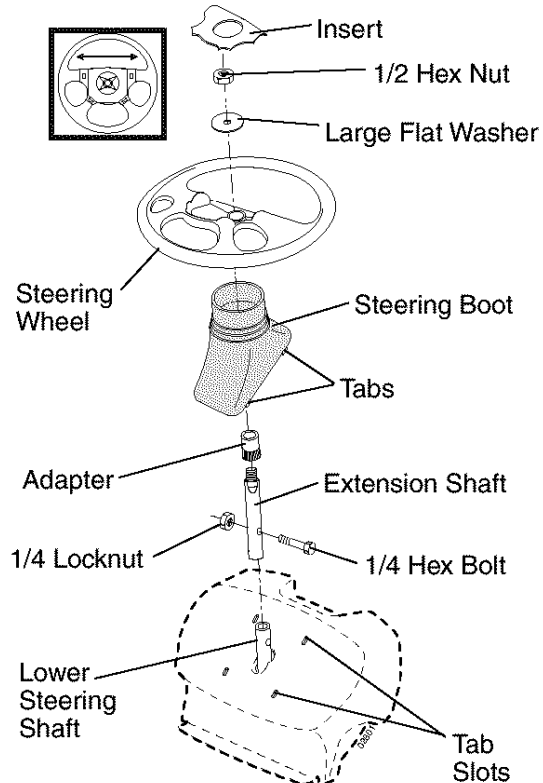

8. Remove protective materials from tractor hood and grill.

IMPORTANT: Check for and remove any staples in skid that may puncture tires where tractor is to roll off skid.

HOW TO SET UP YOUR TRACTOR

CHECK BATTERY

1. Lift hood to raised position.
- NOTE:** If this battery is put into service after month and year indicated on label (label located between terminals) charge battery for minimum of one hour at 6-10 amps. (See "BATTERY" in Maintenance section of this manual for charging instructions).

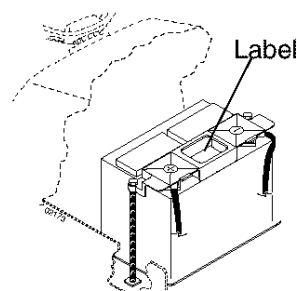

INSTALL SEAT

Adjust seat before tightening adjustment knob.

1. Remove adjustment knob and flat washer securing seat to cardboard packing and set aside for assembly of seat to tractor.
2. Pivot seat upward and remove from the cardboard packing. Remove the cardboard packing and discard.
3. Place seat on seat pan so head of shoulder bolt is positioned over large slotted hole in pan.
4. Push down on seat to engage shoulder bolt in slot and pull seat towards rear of tractor.
5. Pivot seat and pan forward and assemble adjustment knob and flat washer loosely. Do not tighten.
6. Lower seat into operating position and sit in seat.
7. Slide seat until a comfortable position is reached which allows you to press clutch/brake pedal all the way down.
8. Get off seat without moving its adjusted position.
9. Raise seat and tighten adjustment knob securely.

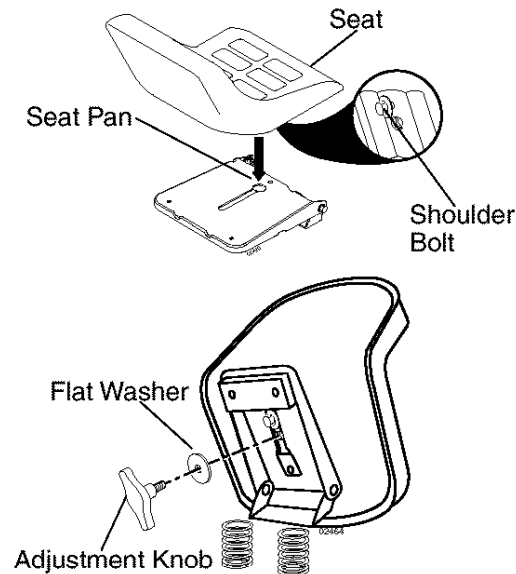

NOTE: You may now roll or drive your tractor off the skid. Follow the appropriate instruction below to remove the tractor from the skid.

TO ROLL TRACTOR OFF SKID (See Operation section for location and function of controls)

1. Press lift lever plunger and raise attachment lift lever to its highest position.

2. Release parking brake by depressing clutch/brake pedal.
3. Place gearshift lever in neutral (N) position.
4. Roll tractor forward off skid.
5. Remove banding holding deflector shield up against tractor.

TO DRIVE TRACTOR OFF SKID (See Operation section for location and function of controls)

WARNING: Before starting, read, understand and follow all instructions in the Operation section of this manual. Be sure tractor is in a well-ventilated area. Be sure the area in front of tractor is clear of other people and objects.

1. Be sure all the above assembly steps have been completed.
2. Check engine oil level and fill fuel tank with gasoline.
3. Sit on seat in operating position, depress clutch/brake pedal and set the parking brake.
4. Place gear shift lever in neutral (N) position.
5. Press lift lever plunger and raise attachment lift lever to its highest position.
6. Start the engine. After engine has started, move throttle control to idle position.
7. Depress clutch/brake pedal into full "BRAKE" position and hold. Move gearshift lever to 1st gear.
8. Slowly release clutch/brake pedal and slowly drive tractor off skid.
9. Apply brake to stop tractor, set parking brake and place gearshift lever in neutral position.
10. Turn ignition key to "STOP" position. Continue with the instructions that follow.

ASSEMBLE GAUGE WHEELS TO MOWER DECK

The gauge wheels are designed to keep the mower deck in proper position when operating mower. Be sure they are properly adjusted to ensure optimum mower performance.

1. Slide gauge wheel bar down into bracket channel, Be sure that gauge wheel bar aligning holes are on top. Assemble gauge wheels as shown using shoulder bolts, 3/8 washers and 3/8-16 center locknuts and tighten securely.

- Adjust gauge wheels before operating mower. See "TO ADJUST GAUGE WHEELS" in the Operation section of this manual.

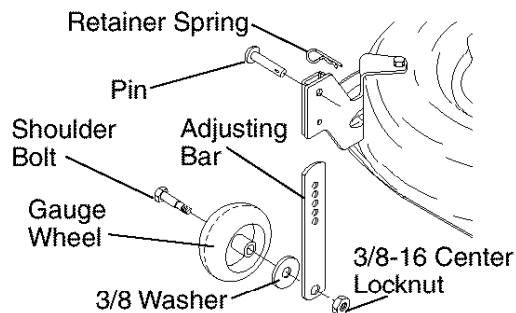

INSTALL MULCHER PLATE (If previously removed)

- Raise and hold deflector shield in upright position.
- Place front of mulcher plate over front of mower deck opening and slide into place, as shown.
- Hook front latch into hole on front of mower deck.
- Hook rear latch into hole on back of mower deck.

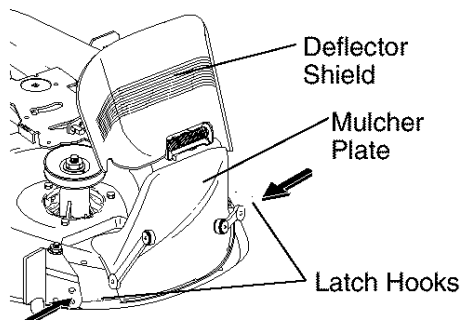

CAUTION: Do not remove deflector shield from mower. Raise and hold shield when attaching mulcher plate and allow it to rest on plate while in operation.

TO CONVERT TO BAGGING OR DISCHARGING

Simply remove mulcher plate and store in a safe place. Your mower is now ready for discharging or installation of optional grass catcher accessory.

NOTE: It is not necessary to change blades. The mulcher blades are designed for discharging and bagging also.

CHECK TIRE PRESSURE

The tires on your tractor were overinflated at the factory for shipping purposes. Correct tire pressure is important for best cutting performance.

- Reduce tire pressure to PSI shown in "PRODUCT SPECIFICATIONS" section of this manual.

CHECK DECK LEVELNESS

For best cutting results, mower housing should be properly leveled. See "TO LEVEL MOWER HOUSING" in the Service and Adjustments section of this manual.

CHECK FOR PROPER POSITION OF ALL BELTS

See the figures that are shown for replacing motion and mower blade drive belts in the Service and Adjustments section of this manual. Verify that the belts are routed correctly.

CHECK BRAKE SYSTEM

After you learn how to operate your tractor, check to see that the brake is properly adjusted. See "TO ADJUST BRAKE" in the Service and Adjustments section of this manual.

✓ CHECKLIST

Before you operate and enjoy your new tractor, we wish to assure that you receive the best performance and satisfaction from this Quality Product.

Please review the following checklist:

- ✓ All assembly instructions have been completed.
- ✓ No remaining loose parts in carton.
- ✓ Battery is properly prepared and charged. (Minimum 1 hour at 6 amps).
- ✓ Seat is adjusted comfortably and tightened securely.
- ✓ All tires are properly inflated. (For shipping purposes, the tires were overinflated at the factory).
- ✓ Be sure mower deck is properly leveled side-to-side/front-to-rear for best cutting results. (Tires must be properly inflated for leveling).
- ✓ Check mower and drive belts. Be sure they are routed properly around pulleys and inside all belt keepers.
- ✓ Check wiring. See that all connections are still secure and wires are properly clamped.

While learning how to use your tractor, pay extra attention to the following important items:

- ✓ Engine oil is at proper level.
- ✓ Fuel tank is filled with fresh, clean, regular unleaded gasoline.
- ✓ Become familiar with all controls - their location and function. Operate them before you start the engine.
- ✓ Be sure brake system is in safe operating condition.

OPERATION

These symbols may appear on your tractor or in literature supplied with the product. Learn and understand their meaning.

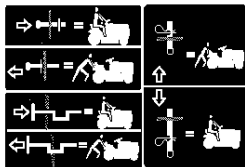
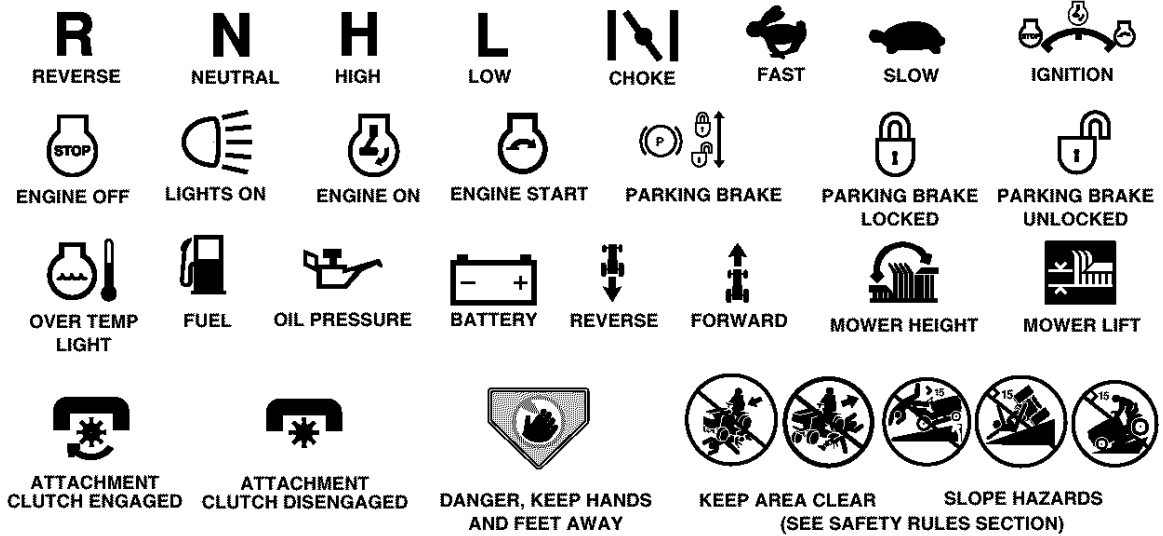

FREE WHEEL
(Automatic Models only)



Failure to follow instructions could result in serious injury or death. The safety alert symbol is used to identify safety information about hazards which can result in death, serious injury and/or property damage.



DANGER indicates a hazard which, if not avoided, will result in death or serious injury.



WARNING indicates a hazard which, if not avoided, could result in death or serious injury.



CAUTION indicates a hazard which, if not avoided, might result in minor or moderate injury.

CAUTION when used **without** the alert symbol, indicates a situation that **could result in damage to the tractor and/or engine.**



HOT SURFACES indicates a hazard which, if not avoided, could result in death, serious injury and/or property damage.



FIRE indicates a hazard which, if not avoided, could result in death, serious injury and/or property damage.

KNOW YOUR TRACTOR

READ THIS OWNER'S MANUAL AND SAFETY RULES BEFORE OPERATING YOUR TRACTOR

Compare the illustrations with your tractor to familiarize yourself with the locations of various controls and adjustments. Save this manual for future reference.

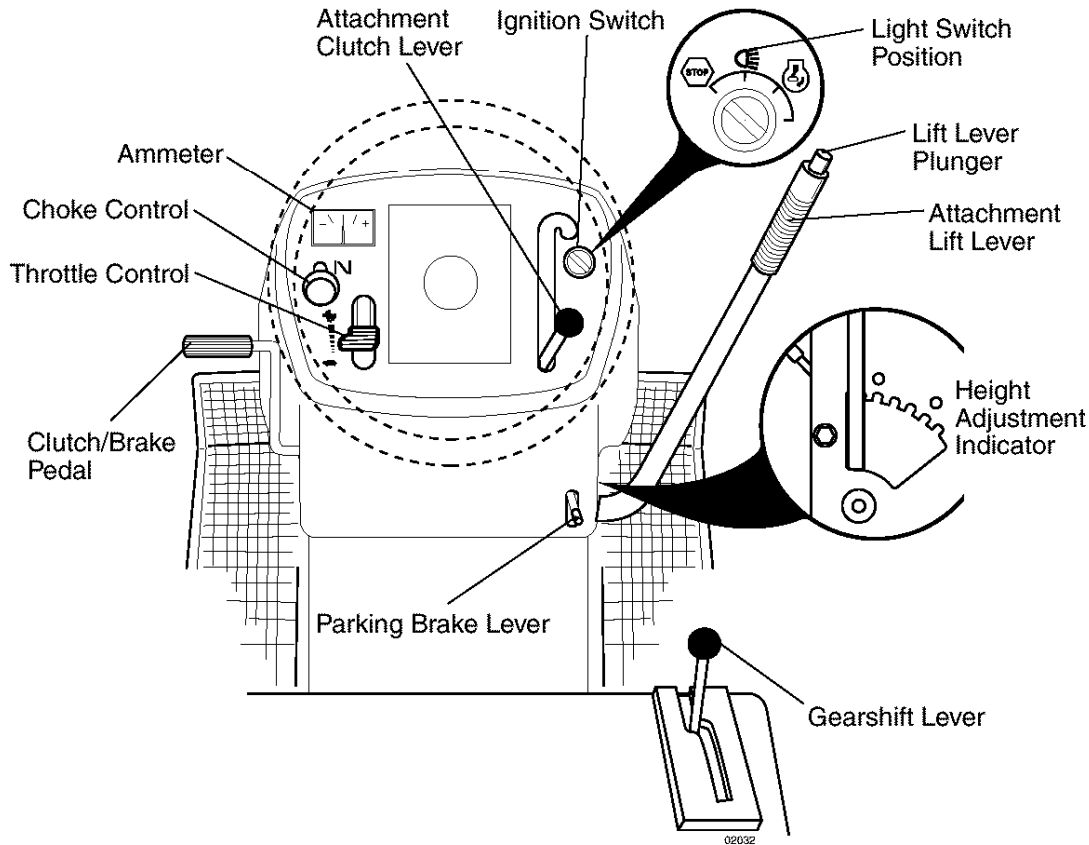

Our tractors conform to the safety standards of the American National Standards Institute.

AMMETER - Indicates charging (+) or discharging (-) of battery.

ATTACHMENT CLUTCH LEVER - Used to engage the mower blades, or other attachments mounted to your tractor.

ATTACHMENT LIFT LEVER - Used to raise, lower, and adjust the mower deck or other attachments mounted to your tractor.

CLUTCH/BRAKE PEDAL - Used for declutching and braking the tractor and starting the engine.

GEARSHIFT LEVER - Selects the speed and direction of tractor.

IGNITION SWITCH - Used for starting and stopping the engine.

LIFT LEVER PLUNGER - Used to release attachment lift lever when changing its position.

LIGHT SWITCH POSITION - Turns the headlights on and off.

PARKING BRAKE LEVER - Locks clutch/brake pedal into the brake position.

THROTTLE CONTROL - Used to control engine speed.

CHOKE CONTROL - Used when starting a cold engine.



The operation of any tractor can result in foreign objects thrown into the eyes, which can result in severe eye damage. Always wear safety glasses or eye shields while operating your tractor or performing any adjustments or repairs. We recommend a wide vision safety mask over spectacles or standard safety glasses.

HOW TO USE YOUR TRACTOR TO SET PARKING BRAKE

Your tractor is equipped with an operator presence sensing switch. When engine is running, any attempt by the operator to leave the seat without first setting the parking brake will shut off the engine.

1. Depress clutch/brake pedal all the way down and hold.
2. Pull parking brake lever up and release pressure from clutch/brake pedal. Pedal should remain in brake position. Make sure parking brake will hold tractor secure.

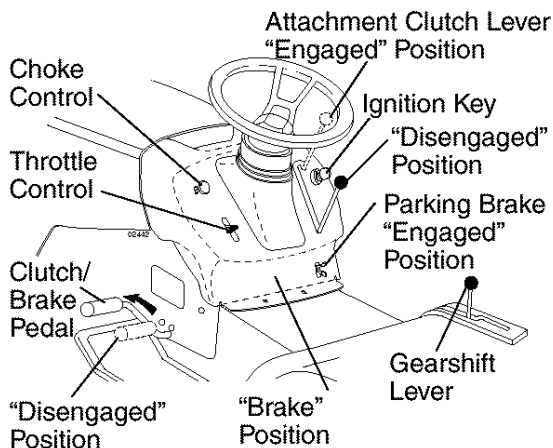

STOPPING

MOWER BLADES -

- To stop mower blades, move attachment clutch lever to disengaged position.

GROUND DRIVE -

- To stop ground drive, depress clutch/brake pedal all the way down.
- Move gearshift lever to neutral (N) position.

ENGINE -

- Move throttle control between half and full speed (fast) position.

NOTE: Failure to move throttle control between half and full speed (fast) position, before stopping, may cause engine to "backfire".

- Turn ignition key to "STOP" position and remove key. Always remove key when leaving tractor to prevent unauthorized use.
- Never use choke to stop engine.

IMPORTANT: Leaving the ignition switch in any position other than "STOP" will cause the battery to discharge and go dead.

NOTE: Under certain conditions when tractor is standing idle with the engine running, hot engine exhaust gases may cause "browning" of grass. To eliminate this possibility, always stop engine when stopping tractor on grass areas.

CAUTION: Always stop tractor completely, as described above, before leaving the operator's position.

TO USE THROTTLE CONTROL

Always operate engine at full throttle.

- Operating engine at less than full throttle reduces the battery charging rate.
- Full throttle offers the best bagging and mower performance.

TO USE CHOKE CONTROL

Use choke control whenever you are starting a cold engine. Do not use to start a warm engine.

- To engage choke control, pull knob out. Slowly push knob in to disengage.

TO MOVE FORWARD AND BACKWARD

The direction and speed of movement is controlled by the gearshift lever.

1. Start tractor with clutch/brake pedal depressed and gearshift lever in neutral (N) position.
2. Move gearshift lever to desired position.
3. Slowly release clutch/brake pedal to start movement.

IMPORTANT: Bring tractor to a complete stop before shifting or changing gears. Failure to do so will shorten the useful life of your transaxle.

TO ADJUST MOWER CUTTING HEIGHT

The position of the attachment lift lever determines the cutting height.

- Grasp lift lever.
- Press plunger with thumb and move lever to desired position.

The cutting height range is approximately 1-1/2 to 4". The heights are measured from the ground to the blade tip with the engine not running. These heights are approximate and may vary depending upon soil conditions, height of grass and types of grass being mowed.

- The average lawn should be cut to approximately 2-1/2 inches during the cool season and to over 3 inches during hot months. For healthier and better looking lawns, mow often and after moderate growth.
- For best cutting performance, grass over 6 inches in height should be mowed twice. Make the first cut relatively high; the second to desired height.

TO ADJUST GAUGE WHEELS

Gauge wheels are properly adjusted when they are slightly off the ground when mower is at the desired cutting height in operating position. Gauge wheels then keep the deck in proper position to help prevent scalping in most terrain conditions.

NOTE: Be sure tractor is on a flat level surface.

1. Lower mower and adjust mower to desired cutting height (See "TO ADJUST MOWER CUTTING HEIGHT" in this section of manual).
2. Remove retainer spring and clevis pin which secure each gauge wheel bar.
3. Lower gauge wheels to ground. Raise gauge wheels slightly to align holes in bracket and gauge wheel bar and insert clevis pin. Gauge wheels should be slightly off the ground.
4. Replace retainer spring into clevis pin.
5. Be sure all gauge wheels are in the same setting.

IMPORTANT: Be sure to readjust gauge wheels if you change the cutting height of the mower deck.

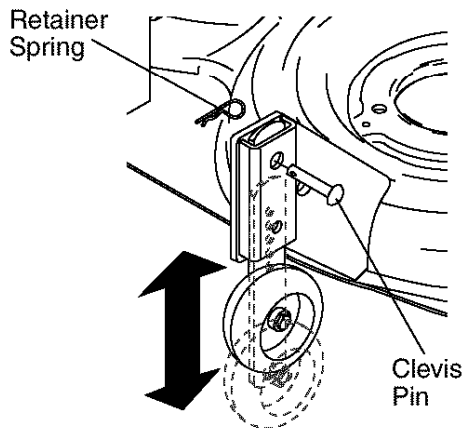

TO OPERATE MOWER

Your tractor is equipped with an operator presence sensing switch. Any attempt by the operator to leave the seat with the engine running and the attachment clutch engaged will shut off the engine.

1. Select desired height of cut.
2. Start mower blades by engaging attachment clutch control.

TO STOP MOWER BLADES - disengage attachment clutch control.

CAUTION: Do not operate the mower without either the entire grass catcher, on mowers so equipped, or the deflector shield in place.

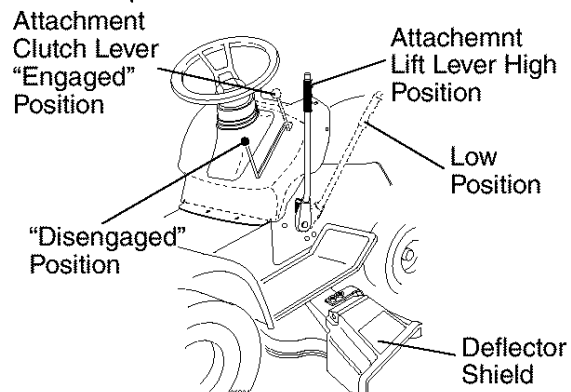

TO OPERATE ON HILLS

WARNING: Do not drive up or down hills with slopes greater than 15° and do not drive across any slope. Use the slope guide at the back of this manual.

- Choose the slowest speed before starting up or down hills.
- Avoid stopping or changing speed on hills.
- If slowing is necessary, move throttle control lever to slower position.
- If stopping is absolutely necessary, push clutch/brake pedal quickly to brake position and engage parking brake.
- Move gearshift lever to 1st gear. Be sure you have allowed room for tractor to roll slightly as you restart movement.
- To restart movement, slowly release parking brake and clutch/brake pedal.
- Make all turns slowly.

TO TRANSPORT

- Raise attachment lift to highest position with attachment lift control.
- When pushing or towing your tractor, be sure gearshift lever is in neutral (N) position.
- Do not push or tow tractor at more than five (5) MPH.

NOTE: To protect hood from damage when transporting your tractor on a truck or a trailer, be sure hood is closed and secured to tractor. Use an appropriate means of tying hood to tractor (rope, cord, etc.).

TOWING CARTS AND OTHER ATTACHMENTS

Tow only the attachments that are recommended by and comply with specifications of the manufacturer of your tractor. Use common sense when towing. Too heavy of a load, while on a slope, is dangerous. Tires can lose traction with the ground and cause you to lose control of your tractor.

BEFORE STARTING THE ENGINE CHECK ENGINE OIL LEVEL

The engine in your tractor has been shipped, from the factory, already filled with summer weight oil.

1. Check engine oil with tractor on level ground.
 2. Unthread and remove oil fill cap/dipstick; wipe oil off. Reinsert the dipstick into the tube and rest oil fill cap on the tube. Do not thread the cap onto the tube. Remove and read oil level. If necessary, add oil until "FULL" mark on dipstick is reached. Do not overfill.
- For cold weather operation you should change oil for easier starting (See the oil viscosity chart in the Maintenance section of this manual).
 - To change engine oil, see the Maintenance section in this manual.

ADD GASOLINE

- Fill fuel tank to bottom of filler neck. Do not overfill. Use fresh, clean, regular unleaded gasoline with a minimum of 87 octane. (Use of leaded gasoline will increase carbon and lead oxide deposits and reduce valve life). Do not mix oil with gasoline. Purchase fuel in quantities that can be used within 30 days to assure fuel freshness.

 **CAUTION:** Wipe off any spilled oil or fuel. Do not store, spill or use gasoline near an open flame.

IMPORTANT: When operating in temperatures below 32°F (0°C), use fresh, clean winter grade gasoline to help insure good cold weather starting.

CAUTION: Alcohol blended fuels (called gasohol or using ethanol or methanol) can attract moisture which leads to separation and formation of acids during storage. Acidic gas can damage the fuel system of an engine while in storage. To avoid engine problems, the fuel system should be emptied before storage of 30 days or longer. Drain the gas tank, start the engine and let it run until the fuel lines and carburetor are empty. Use fresh fuel next season. See Storage Instructions for additional information. Never use engine or carburetor cleaner products in the fuel tank or permanent damage may occur.

TO START ENGINE

When starting the engine for the first time or if the engine has run out of fuel, it will take extra cranking time to move fuel from the tank to the engine.

1. Sit on seat in operating position, depress clutch/brake pedal and set parking brake.
2. Place gear shift lever in neutral (N) position.
3. Move attachment clutch to disengaged position.
4. Move throttle control to fast position
5. Pull choke control out for a cold engine start attempt. For a warm engine start attempt the choke control may not be needed.

NOTE: Before starting, read the warm and cold starting procedures below.

6. Insert key into ignition and turn key clockwise to start position and release key as soon as engine starts. Do not run starter continuously for more than fifteen seconds per minute. If the engine does not start after several attempts, push choke control in, wait a few minutes and try again. If engine still does not start, pull the choke control out and retry.

WARM WEATHER STARTING (50° F and above)

7. When engine starts, slowly push choke control in until the engine begins to run smoothly. If the engine starts to run roughly, pull the choke control out slightly for a few seconds and then continue to push the control in slowly.
- The attachments and ground drive can now be used. If the engine does not accept the load, restart the engine and allow it to warm up for one minute using the choke as described above.

COLD WEATHER STARTING (50° F and below)

- When engine starts, slowly push choke control in until the engine begins to run smoothly. Continue to push the choke control in small steps allowing the engine to accept small changes in speed and load, until the choke control is fully in. If the engine starts to run roughly, pull the choke control out slightly for a few seconds and then continue to push the control in slowly. This may require an engine warm-up period from several seconds to several minutes, depending on the temperature.

- The attachments can be used during the engine warm-up period and may require the choke control be pulled out slightly.

NOTE: If at a high altitude (above 3000 feet) or in cold temperatures (below 32 F) the carburetor fuel mixture may need to be adjusted for best engine performance (see "TO ADJUST CARBURETOR" in the Service and Adjustments section of this manual).

MOWING TIPS

- Mower should be properly leveled for best mowing performance. See "TO LEVEL MOWER HOUSING" in the Service and Adjustments section of this manual.
- The left hand side of mower should be used for trimming.
- Drive so that clippings are discharged onto the area that has already been cut. Have the cut area to the right of the tractor. This will result in a more even distribution of clippings and more uniform cutting.
- When mowing large areas, start by turning to the right so that clippings will discharge away from shrubs, fences, driveways, etc. After one or two rounds, mow in the opposite direction making left hand turns until finished.

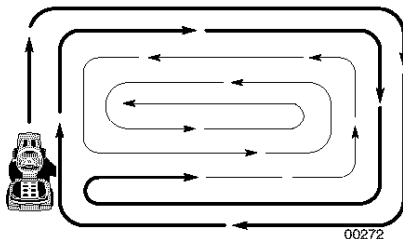

- If grass is extremely tall, it should be mowed twice to reduce load and possible fire hazard from dried clippings. Make first cut relatively high; the second to the desired height.
- Do not mow grass when it is wet. Wet grass will plug mower and leave undesirable clumps. Allow grass to dry before mowing.

- Always operate engine at full throttle when mowing to assure better mowing performance and proper discharge of material.** Regulate ground speed by selecting a low enough gear to give the mower cutting performance as well as the quality of cut desired.
- When operating attachments, select a ground speed that will suit the terrain and give best performance of the attachment being used.

MULCHING MOWING TIPS

IMPORTANT: For best performance, keep mower housing free of built-up grass and trash. Clean after each use.

- The special mulching blade will recut the grass clippings many times and reduce them in size so that as they fall onto the lawn they will disperse into the grass and not be noticed. Also, the mulched grass will biodegrade quickly to provide nutrients for the lawn. Always mulch with your highest engine (blade) speed as this will provide the best recutting action of the blades.
- Avoid cutting your lawn when it is wet. Wet grass tends to form clumps and interferes with the mulching action. The best time to mow your lawn is the early afternoon. At this time the grass has dried, the newly cut area will not be exposed to direct sunlight.
- For best results, adjust the mower cutting height so that the mower cuts off only the top one-third of the grass blades. For extremely heavy grass, reduce your width of cut on each pass and mow slowly.

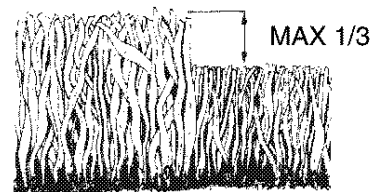

- Certain types of grass and grass conditions may require that an area be mulched a second time to completely hide the clippings. When doing a second cut, mow across (perpendicular) to the first cut path.
- Change your cutting pattern from week to week. Mow north to south one week then change to east to west the next week. This will help prevent matting and graining of the lawn.

TRACTOR

Always observe safety rules when performing any maintenance.

BRAKE OPERATION

If tractor requires more than six (6) feet stopping distance at high speed in highest gear, then brake must be adjusted. (See "TO ADJUST BRAKE" in the Service and Adjustments section of this manual).

TIRES

- Maintain proper air pressure in all tires (See "PRODUCT SPECIFICATIONS" section of this manual).
- Keep tires free of gasoline, oil, or insect control chemicals which can harm rubber.
- Avoid stumps, stones, deep ruts, sharp objects and other hazards that may cause tire damage.

NOTE: To seal tire punctures and prevent flat tires due to slow leaks, tire sealant may be purchased from your local parts dealer. Tire sealant also prevents tire dry rot and corrosion.

OPERATOR PRESENCE SYSTEM

Be sure operator presence and interlock systems are working properly. If your tractor does not function as described, repair the problem immediately.

- The engine should not start unless the clutch/brake pedal is fully depressed and attachment clutch control is in the disengaged position.
- When the engine is running, any attempt by the operator to leave the seat without first setting the parking brake should shut off the engine.
- When the engine is running and the attachment clutch is engaged, any attempt by the operator to leave the seat should shut off the engine.
- The attachment clutch should never operate unless the operator is in the seat.

BLADE CARE

For best results mower blades must be kept sharp. Replace bent or damaged blades.

BLADE REMOVAL

1. Raise mower to highest position to allow access to blades.
2. Remove blade bolt, lock washer and flat washer securing blade.
3. Install new or resharpened blade with trailing edge up towards deck as shown.

IMPORTANT: To ensure proper assembly, center hole in blade must align with star on mandrel assembly.

4. Reassemble blade bolt, lock washer and flat washer in exact order as shown.
5. Tighten blade bolt securely (27-35 Ft. Lbs. torque).

IMPORTANT: Blade bolt is heat treated. If bolt needs replacing, replace only with approve bolt shown in the Repair Parts.

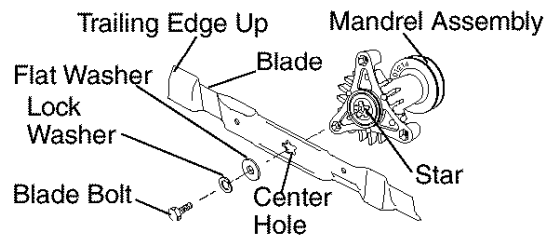

TO SHARPEN BLADE

NOTE: We do not recommend sharpening blade - but if you do, be sure the blade is balanced.

Care should be taken to keep the blade balanced. An unbalanced blade will cause excessive vibration and eventual damage to mower and engine.

- The blade can be sharpened with a file or on a grinding wheel. Do not attempt to sharpen while on the mower.
- To check blade balance, you will need a 5/8" diameter steel bolt, pin, or a cone balancer. (When using a cone balancer, follow the instructions supplied with balancer.)

NOTE: Do not use a nail for balancing blade. The lobes of the center hole may appear to be centered, but are not.

- Slide blade on to an unthreaded portion of the steel bolt or pin and hold the bolt or pin parallel with the ground. If blade is balanced, it should remain in a horizontal position. If either end of the blade moves downward, sharpen the heavy end until the blade is balanced.

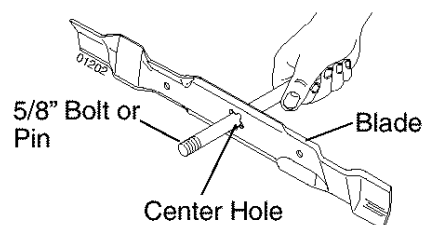

1. Loosen knob and remove cover.

TO SERVICE PRE-CLEANER

2. Slide foam pre-cleaner off cartridge.
3. Wash it in liquid detergent and water.
4. Squeeze it dry in a clean cloth. Allow it to dry.
5. Saturate it in engine oil. Wrap it in clean, absorbent cloth and squeeze to remove excess oil.

TO SERVICE CARTRIDGE

- Replace a dirty, bent, or damaged cartridge.

NOTE: Do not wash the paper cartridge or use pressurized air, as this will damage the cartridge.

1. Remove nut and cartridge plate.
2. Reinstall the pre-cleaner (cleaned and oiled) over the paper cartridge.
3. Check rubber seal for damage and proper position around stud. Replace if necessary.
4. Reassemble air cleaner, cartridge plate, and nut.
5. Reinstall air cleaner cover and secure by tightening knob.

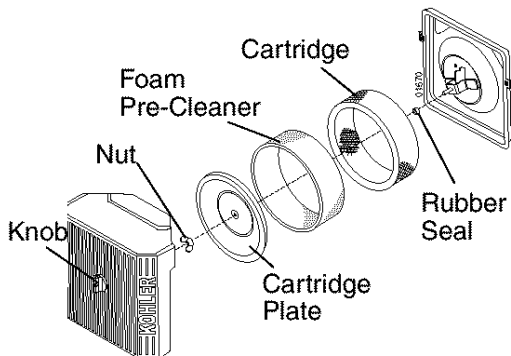

CLEAN AIR SCREEN

Air screen must be kept free of dirt and chaff to prevent engine damage from overheating. Clean with a wire brush or compressed air to remove dirt and stubborn dried gum fibers.

CLEAN AIR INTAKE/COOLING AREAS

To insure proper cooling, make sure the grass screen, cooling fins, and other external surfaces of the engine are kept clean at all times.

Every 100 hours of operation (more often under extremely dusty, dirty conditions), remove the blower housing and other cooling shrouds. Clean the cooling fins and external surfaces as necessary. Make sure the cooling shrouds are reinstalled.

NOTE: Operating the engine with a blocked grass screen, dirty or plugged cooling fins, and/or cooling shrouds removed will cause engine damage due to overheating.

ENGINE OIL FILTER

Replace the engine oil filter every season or every other oil change if the tractor is used more than 100 hours in one year.

MUFFLER

Inspect and replace corroded muffler and spark arrester (if equipped) as it could create a fire hazard and/or damage.

SPARK PLUG(S)

Replace spark plug(s) at the beginning of each mowing season or after every 100 hours of operation, whichever occurs first. Spark plug type and gap setting are shown in "PRODUCT SPECIFICATIONS" section of this manual.

IN-LINE FUEL FILTER

The fuel filter should be replaced once each season. If fuel filter becomes clogged, obstructing fuel flow to carburetor, replacement is required.

1. With engine cool, remove filter and plug fuel line sections.
2. Place new fuel filter in position in fuel line with arrow pointing towards carburetor.
3. Be sure there are no fuel line leaks and clamps are properly positioned.
4. Immediately wipe up any spilled gasoline.

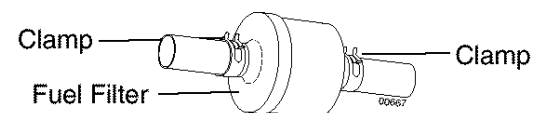

CLEANING

- Clean engine, battery, seat, finish, etc. of all foreign matter.
- Keep finished surfaces and wheels free of all gasoline, oil, etc.
- Protect painted surfaces with automotive type wax.

We do not recommend using a garden hose or pressure washer to clean your tractor unless the engine and transmission are covered to keep water out. Water in engine or transmission will shorten the useful life of your tractor. Use compressed air or a leaf blower to remove grass, leaves and trash from tractor and mower.

SERVICE AND ADJUSTMENTS



WARNING: TO AVOID SERIOUS INJURY, BEFORE PERFORMING ANY SERVICE OR ADJUSTMENTS:

1. Depress clutch/brake pedal fully and set parking brake.
2. Place gearshift lever in neutral (N) position.
3. Place attachment clutch in "DISENGAGED" position.
4. Turn ignition key to "STOP" and remove key.
5. Make sure the blades and all moving parts have completely stopped.
6. Disconnect spark plug wire from spark plug and place wire where it cannot come in contact with plug.

TRACTOR

TO REMOVE MOWER

Mower will be easier to remove from the right side of tractor.

1. Place attachment clutch in "DISENGAGED" position.
2. Move attachment lift lever forward to lower mower to its lowest position.
3. Roll belt off engine pulley.
4. Remove small retainer spring, and remove clutch spring off pulley bolt.
5. Remove large retainer spring, slide collar off and push housing guide out of bracket.
6. Disconnect anti-sway bar from chassis bracket by removing retainer spring.
7. Disconnect suspension arms from rear deck brackets by removing retainer springs.
8. Disconnect front links from deck by removing retainer springs.

9. Raise lift lever to raise suspension arms. Slide mower out from under tractor.

IMPORTANT: If an attachment other than the mower deck is to be mounted on the tractor, remove the front links and hook the clutch spring into square hole in frame.

TO INSTALL MOWER

1. Raise attachment lift lever to its highest position.
2. Slide mower under tractor with deflector shield to right side of tractor.
3. Lower lift lever to its lowest position.
4. Connect front links to mower deck and secure with retainer springs.
5. Connect suspension arms to rear deck brackets and secure with retainer springs.
6. Connect anti-sway bar to chassis bracket and secure with retainer spring.

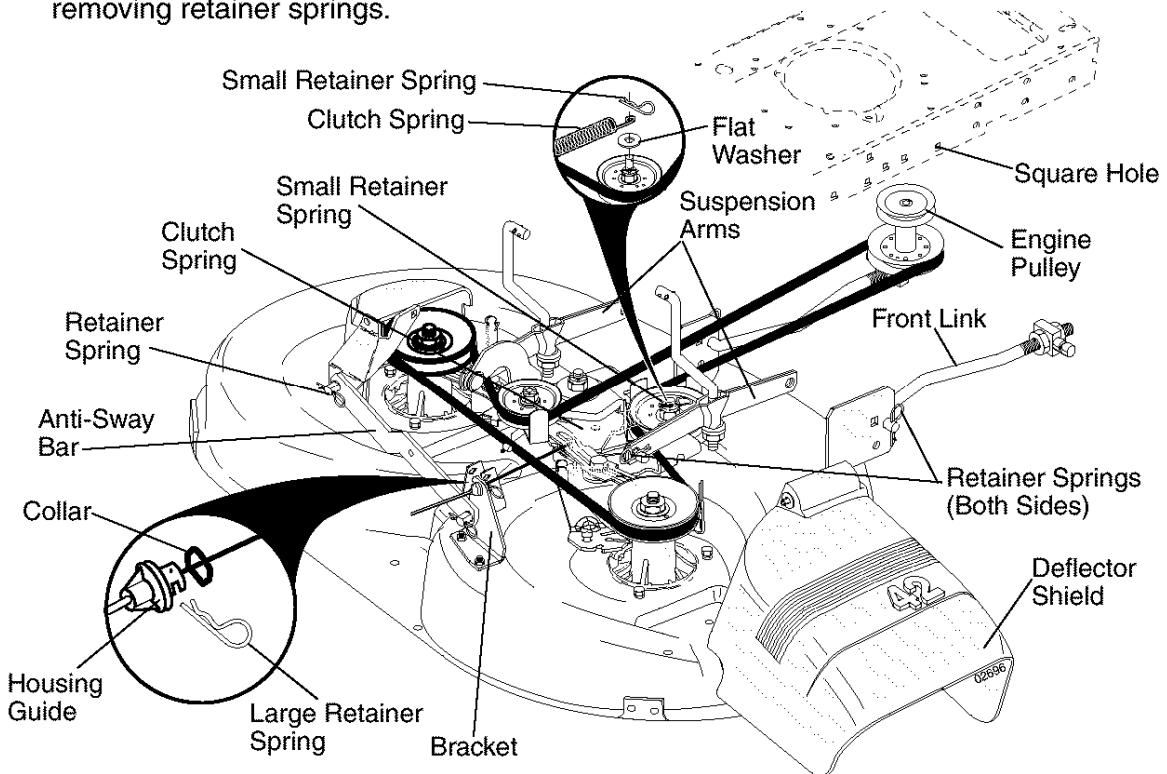

7. Push clutch cable housing guide into bracket, slide collar onto guide and secure with large retainer spring.
8. Place flat washer and clutch spring on idler pulley bolt and secure with small retainer spring.
9. Install belt onto engine pulley.

TO LEVEL MOWER HOUSING

Adjust the mower while tractor is parked on level ground or driveway. Make sure tires are properly inflated (See "PRODUCT SPECIFICATIONS" section of this manual). If tires are over or underinflated, you will not properly adjust your mower.

SIDE-TO-SIDE ADJUSTMENT

- Raise mower to its highest position.
- At the midpoint of both sides of mower, measure height from bottom edge of mower to ground. Distance "A" on both sides of mower should be the same or within 1/4" of each other.
- If adjustment is necessary, make adjustment on one side of mower only.
- To raise one side of mower, tighten lift link adjustment nut on that side.
- To lower one side of mower, loosen lift link adjustment nut on that side.

NOTE: Each full turn of adjustment nut will change mower height about 1/8".

- Recheck measurements after adjusting.

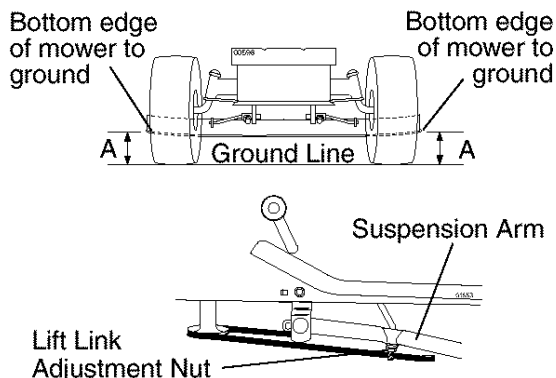

FRONT-TO-BACK ADJUSTMENT

IMPORTANT: Deck must be level side-to-side. If the following front-to-back adjustment is necessary, be sure to adjust both front links equally so mower will stay level side-to-side.

To obtain the best cutting results, the mower housing should be adjusted so that the front is approximately 1/8" to 1/2" lower than the rear when the mower is in its highest position.

Check adjustment on right side of tractor. Measure distance "D" directly in front and behind the mandrel at bottom edge of mower housing as shown.

- Before making any necessary adjustments, check that both front links are equal in length.
- If links are not equal in length, adjust one link to same length as other link.
- To lower front of mower loosen nut "E" on both front links an equal number of turns.
- When distance "D" is 1/8" to 1/2" lower at front than rear, tighten nuts "F" against trunnion on both front links.
- To raise front of mower, loosen nut "F" from trunnion on both front links. Tighten nut "E" on both front links an equal number of turns. The two front links must remain equal in length.
- When distance "D" is 1/8" to 1/2" lower at front than rear, tighten nut "F" against trunnion on both front links.
- Recheck side-to-side adjustment.

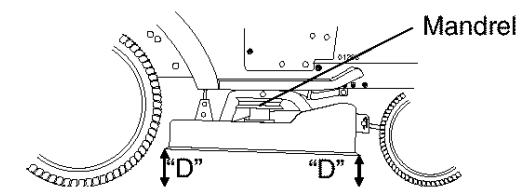

Both Front Links Should be Equal in Length

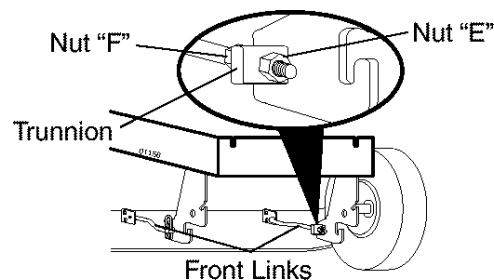
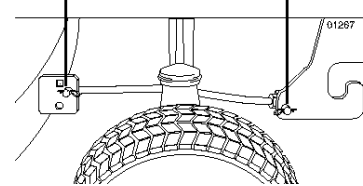

TO REPLACE MOWER BLADE DRIVE BELT

The mower blade drive belt may be replaced without tools. Park the tractor on level surface. Engage parking brake.

BELT REMOVAL -

1. Remove mower from tractor (See "TO REMOVE MOWER" in this section of manual).
2. Work belt off both mandrel pulleys and idler pulleys.
3. Pull belt away from mower.

BELT INSTALLATION -

1. Work belt around both mandrel pulleys and idler pulleys
2. Make sure belt is in all pulley grooves and inside all belt guides.
3. Install mower (See "To Install Mower" in this section of this manual).

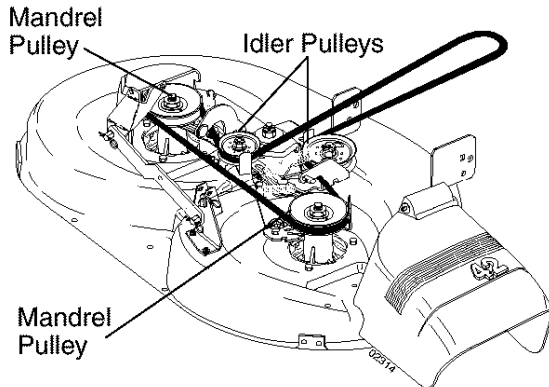

TO CHECK AND ADJUST BRAKE

Your tractor is equipped with an adjustable brake system which is mounted on the right side of the transaxle.

If tractor requires more than five (5) feet to stop at highest speed in highest gear on a level, dry concrete or paved surface, then brake must be checked and adjusted.

TO CHECK BRAKE

1. Park tractor on a level, dry concrete or paved surface, depress clutch/brake pedal all the way down and engage parking brake.
2. Place gear shift lever in neutral (N) position.

The rear wheels must lock and skid when you try to manually push the tractor forward. If the rear wheels rotate, the brake needs to be adjusted or the pads need to be replaced.

TO ADJUST BRAKE

1. Depress clutch/brake pedal all the way down and engage parking brake.
2. Measure distance between brake operating arm and nut "A" on brake rod.
3. If distance is other than 1-1/2", loosen jam nut and turn nut "A" until distance becomes 1-1/2". Retighten jam nut against nut "A".
4. Road test tractor for proper stopping distance as stated above. Readjust if necessary. If stopping distance is still greater than five (5) feet in highest gear, further maintenance is necessary. Replace brake pads or contact a Sears or other qualified service center.

With Parking Brake "Engaged"

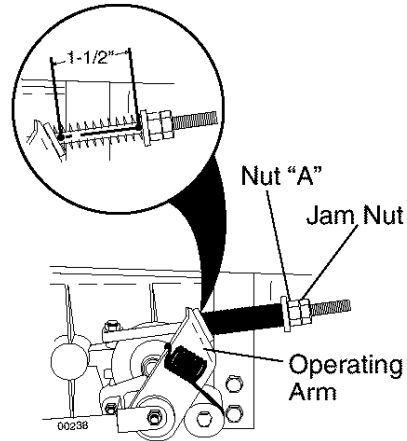

TO REPLACE MOTION DRIVE BELT

Park the tractor on level surface. Engage parking brake. For assistance, there is a belt installation guide decal on bottom side of left footrest.

BELT REMOVAL -

1. Remove mower (See "TO REMOVE MOWER" in this section of manual).
- NOTE:** Observe entire motion drive belt and position of all belt guides and keepers.
2. Remove belt from stationary idler and clutching idler.
3. Remove belt downward from around engine pulley.
4. Pull belt slack toward rear of tractor. Remove belt upwards from transaxle pulley by deflecting belt keepers.
5. Remove belt from center span keeper and pull belt away from tractor.

BELT INSTALLATION -

1. Carefully work new belt down between transaxle belt keepers and onto the input pulley.
2. Slide belt into the center span keeper.
3. Pull belt toward front of tractor and roll around the top groove of engine pulley.
4. Install belt through stationary idler and clutching idler.
5. Make sure belt is in all pulley grooves and inside all belt guides and keepers.
6. Install mower (See "TO INSTALL MOWER" in this section of manual).

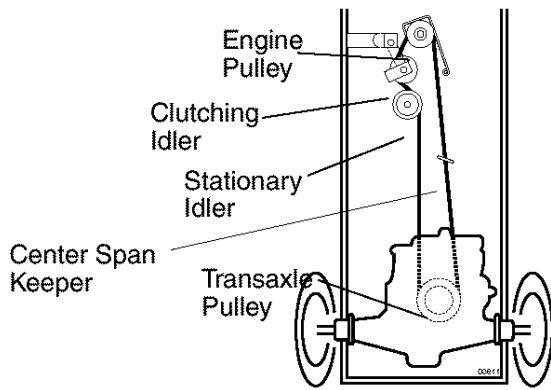

TRANSAXLE GEAR SHIFT LEVER NEUTRAL ADJUSTMENT

The transaxle should be in neutral when the gear shift lever is in neutral (N) (lock gate) position. The adjustment is preset at the factory; however, if adjustment is needed, proceed as follows:

1. Make sure transaxle is in neutral (N).
2. Loosen adjustment bolt in front of the right rear wheel.
3. Position the gear shift lever in the neutral (N) position.
4. Tighten adjustment bolt securely.

NOTE: If additional clearance is needed to get to adjustment bolt, move mower deck height to the lowest position.

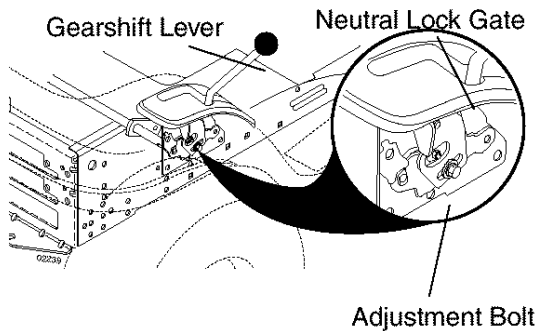

TO ADJUST STEERING WHEEL ALIGNMENT

If steering wheel crossbars are not horizontal (left to right) when wheels are positioned straight forward, remove steering wheel and reassemble with crossbars horizontal. Tighten securely.

FRONT WHEEL TOE-IN/CAMBER

The front wheel toe-in and camber are not adjustable on your tractor. If damage has occurred to affect the front wheel toe-in or camber, contact a Sears or other qualified service center.

TO REMOVE WHEEL FOR REPAIRS

1. Block up axle securely.
2. Remove axle cover, retaining ring and washers to allow wheel removal (rear wheels have a square key - Do not lose).
3. Repair tire and reassemble.

NOTE: On rear wheels only: align grooves in rear wheel hub and axle. Insert square key.

4. Replace washers and snap retaining ring securely in axle groove.
5. Replace axle cover.

NOTE: To seal tire punctures and prevent flat tires due to slow leaks, purchase and use tire sealant from Sears. Tire sealant also prevents tire dry rot and corrosion.

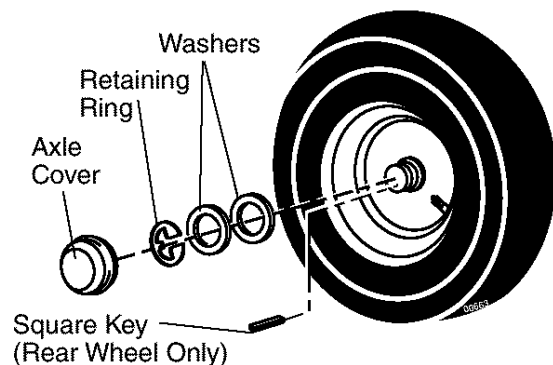

TO START ENGINE WITH A WEAK BATTERY

WARNING: Lead-acid batteries generate explosive gases. Keep sparks, flame and smoking materials away from batteries. Always wear eye protection when around batteries.

If your battery is too weak to start the engine, it should be recharged. (See "BATTERY" in the MAINTENANCE section of this manual).

If "jumper cables" are used for emergency starting, follow this procedure:

IMPORTANT: Your tractor is equipped with a 12 volt system. The other vehicle must also be a 12 volt system. Do not use your tractor battery to start other vehicles.

TO ATTACH JUMPER CABLES -

1. Connect one end of the RED cable to the POSITIVE (+) terminal of each battery(A-B), taking care not to short against tractor chassis.
2. Connect one end of the BLACK cable to the NEGATIVE (-) terminal (C) of fully charged battery.
3. Connect the other end of the BLACK cable (D) to good chassis ground, away from fuel tank and battery.

TO REMOVE CABLES, REVERSE ORDER -

1. BLACK cable first from chassis and then from the fully charged battery.
2. RED cable last from both batteries.

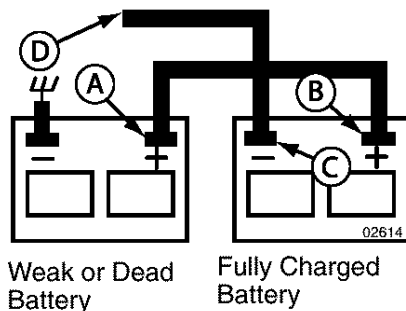

REPLACING BATTERY

⚠ WARNING: Do not short battery terminals by allowing a wrench or any other object to contact both terminals at the same time. Before connecting battery, remove metal bracelets, wristwatch bands, rings, etc.

Positive terminal must be connected first to prevent sparking from accidental grounding.

1. Lift hood to raised position.
2. Remove terminal guard.
3. Disconnect BLACK battery cable then RED battery cable and carefully remove battery from tractor.
4. Install new battery with terminals in same position as old battery.
5. Reinstall terminal guard.
6. First connect RED battery cable to positive (+) battery terminal with hex bolt and keps nut as shown. Tighten securely.
7. Connect BLACK grounding cable to negative (-) battery terminal with remaining hex bolt and keps nut. Tighten securely.
8. Close terminal access doors.
9. Close hood.

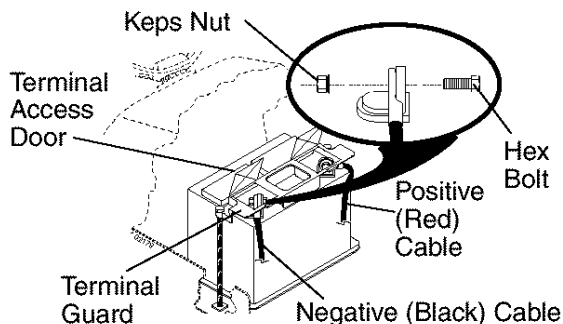

TO REPLACE HEADLIGHT BULB

1. Raise hood.
2. Pull bulb holder out of the hole in the backside of the grill.

3. Replace bulb in holder and push bulb holder securely back into the hole in the backside of the grill.
4. Close hood.

INTERLOCKS AND RELAYS

Loose or damaged wiring may cause your tractor to run poorly, stop running, or prevent it from starting.

- Check wiring. See electrical wiring diagram in the Repair Parts section.

TO REPLACE FUSE

Replace with 20 amp automotive-type plug-in fuse. The fuse holder is located behind the dash.

TO REMOVE HOOD AND GRILL ASSEMBLY

1. Raise hood.
2. Unsnap headlight wire connector.
3. Stand in front of tractor. Grasp hood at sides, tilt toward engine and lift off of tractor.
4. When replacing hood, be sure to reconnect the headlight wire connector.

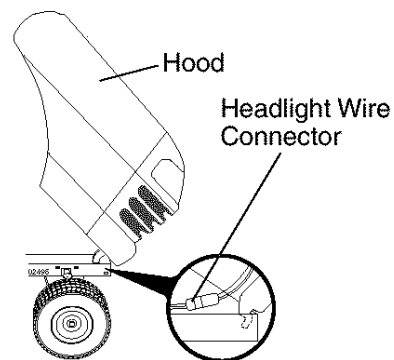

ENGINE

Maintenance, repair, or replacement of the emission control devices and systems, which are being done at the customer's expense, may be performed by any non-road engine repair establishment or individual. Warranty repairs must be performed by an authorized engine manufacturer's service outlet.

TO ADJUST THROTTLE CONTROL CABLE

The throttle control has been preset at the factory and adjustment should not be necessary. Check adjustment as described below before loosening cable. If adjustment is necessary, proceed as follows:

1. With engine not running, move throttle control lever to fast position.
2. Check that speed control lever is against stop screw. If it is not, loosen casing clamp screw and pull throttle cable until lever is against screw. Tighten clamp screw securely.

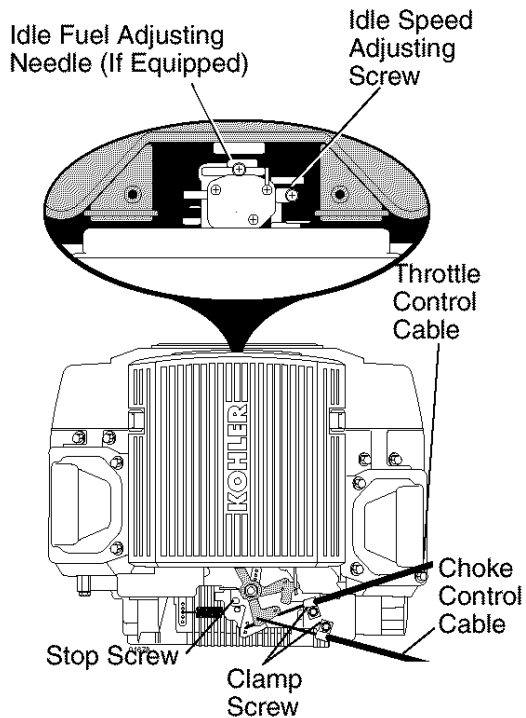

TO ADJUST CHOKE CONTROL

The choke control has been preset at the factory and adjustment should not be necessary. Check adjustment as described below before loosening cable. If adjustment is necessary, proceed as follows:

1. With engine not running, move choke control (located on dash panel) to full choke position.
2. Remove air cleaner cover, filter and cartridge plate to expose carburetor choke (See "AIR FILTER" in the Maintenance section of this manual).
3. Choke should be closed. If it is not, loosen casing clamp screw and move choke cable until choke is completely closed. Tighten casing clamp screw securely.
4. Reassemble air cleaner.

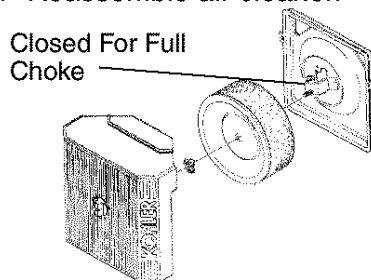

TO ADJUST CARBURETOR

The carburetor has been preset at the factory and adjustment should not be necessary. However, minor adjustment may be required to compensate for differences in fuel, temperature, altitude or load. If the carburetor does need adjustment, proceed as follows:

In general, turning the adjusting needles **in** (clockwise) decreases the supply of fuel to the engine giving a leaner fuel/air mixture. Turning the adjusting needles **out** (counterclockwise) increases the supply of fuel to the engine giving a richer fuel/air mixture.

IMPORTANT: Damage to the needles and the seats in carburetor may result if screw is turned in too tight.

PRELIMINARY SETTING -

1. Be sure you have a clean air filter, and the throttle control cable is adjusted properly (see "TO ADJUST THROTTLE CONTROL CABLE" in the Service and Adjustments section of this manual).
2. With engine off turn idle fuel adjusting needle **in** (clockwise) closing it finger tight and then turn **out** (counterclockwise) 1 turn.

FINAL SETTING -

1. Start engine and allow to warm for five minutes. Make final adjustments with engine running and shift/motion control lever in neutral (N) position.

NOTE: The high idle is set at the factory and cannot be adjusted.

2. Idle speed setting - With throttle control lever in slow position, engine should idle at 1750 RPM. If engine idles too slow or fast, turn idle speed adjusting screw in or out until correct idle is attained.
3. Idle fuel needle setting - With throttle control lever in slow position, turn idle fuel adjusting needle **in** (clockwise) until engine speed decreases and then turn **out** (counterclockwise) approximately 3/4 turn to obtain the best low speed performance.
4. Recheck idle speed. Readjust if necessary.

ACCELERATION TEST -

5. Move throttle control lever from slow to fast position. If engine hesitates or dies, turn idle fuel adjusting needle **out** (counterclockwise) 1/8 turn. Repeat test and continue to adjust, if necessary, until engine accelerates smoothly.

High speed stop is factory adjusted. Do not adjust-damage may result.

IMPORTANT: Never tamper with the engine governor, which is factory set for proper engine speed. Overspeeding the engine above the factory high speed setting can be dangerous. If you think the engine-governed high speed needs adjusting, contact a Sears or other qualified service center, which has proper equipment and experience to make any necessary adjustments.

STORAGE

Immediately prepare your tractor for storage at the end of the season or if the tractor will not be used for 30 days or more.

⚠ WARNING: Never store the tractor with gasoline in the tank inside a building where fumes may reach an open flame or spark. Allow the engine to cool before storing in any enclosure.

TRACTOR

Remove mower from tractor for winter storage. When mower is to be stored for a period of time, clean it thoroughly, remove all dirt, grease, leaves, etc. Store in a clean, dry area.

1. Clean entire tractor (See "CLEANING" in the Maintenance section of this manual).
2. Inspect and replace belts, if necessary (See belt replacement instructions in the Service and Adjustments section of this manual).
3. Lubricate as shown in the Maintenance section of this manual.
4. Be sure that all nuts, bolts and screws are securely fastened. Inspect moving parts for damage, breakage and wear. Replace if necessary.
5. Touch up all rusted or chipped paint surfaces; sand lightly before painting.

BATTERY

- Fully charge the battery for storage.
- After a period of time in storage, battery may require recharging.
- To help prevent corrosion and power leakage during long periods of storage, battery cables should be disconnected and battery cleaned thoroughly (see "TO CLEAN BATTERY AND TERMINALS" in the Maintenance section of this manual).
- After cleaning, leave cables disconnected and place cables where they cannot come in contact with battery terminals.
- If battery is removed from tractor for storage, do not store battery directly on concrete or damp surfaces.

ENGINE

FUEL SYSTEM

IMPORTANT: It is important to prevent gum deposits from forming in essential fuel system parts such as carburetor, fuel hose, or tank during storage. Also, alcohol

blended fuels (called gasohol or using ethanol or methanol) can attract moisture which leads to separation and formation of acids during storage. Acidic gas can damage the fuel system of an engine while in storage.

- Empty the fuel tank by starting the engine and letting it run until the fuel lines and carburetor are empty.
- Never use engine or carburetor cleaner products in the fuel tank or permanent damage may occur.
- Use fresh fuel next season.

NOTE: Fuel stabilizer is an acceptable alternative in minimizing the formation of fuel gum deposits during storage. Add stabilizer to gasoline in fuel tank or storage container. Always follow the mix ratio found on stabilizer container. Run engine at least 10 minutes after adding stabilizer to allow the stabilizer to reach the carburetor. Do not empty the gas tank and carburetor if using fuel stabilizer.

ENGINE OIL

Drain oil (with engine warm) and replace with clean engine oil. (See "ENGINE" in the Maintenance section of this manual).

CYLINDER(S)

1. Remove spark plug(s).
2. Pour one ounce of oil through spark plug hole(s) into cylinder(s).
3. Turn ignition key to "START" position for a few seconds to distribute oil.
4. Replace with new spark plug(s).

OTHER

- Do not store gasoline from one season to another.
- Replace your gasoline can if your can starts to rust. Rust and/or dirt in your gasoline will cause problems.
- If possible, store your tractor indoors and cover it to give protection from dust and dirt.
- Cover your tractor with a suitable protective cover that does not retain moisture. Do not use plastic. Plastic cannot breathe which allows condensation to form and will cause your tractor to rust.

IMPORTANT: Never cover tractor while engine and exhaust areas are still warm.

TROUBLESHOOTING CHART:

See appropriate section in manual unless directed to Sears service center

PROBLEM	CAUSE	CORRECTION
Will not start	<ol style="list-style-type: none"> 1. Out of fuel. 2. Engine not "CHOKED" properly. 3. Engine flooded. 4. Bad spark plug. 5. Dirty air filter. 6. Dirty fuel filter. 7. Water in fuel. 8. Loose or damaged wiring. 9. Carburetor out of adjustment. 10. Engine valves out of adjustment. 	<ol style="list-style-type: none"> 1. Fill fuel tank. 2. See "TO START ENGINE" in Operation section. 3. Wait several minutes before attempting to start. 4. Replace spark plug. 5. Clean/replace air filter. 6. Replace fuel filter. 7. Empty fuel tank and carburetor, refill tank with fresh gasoline and replace fuel filter. 8. Check all wiring. 9. See "To Adjust Carburetor" in Service and Adjustments section. 10. Contact a Sears or other qualified service center.
Hard to start	<ol style="list-style-type: none"> 1. Dirty air filter. 2. Bad spark plug. 3. Weak or dead battery. 4. Dirty fuel filter. 5. Stale or dirty fuel. 6. Loose or damaged wiring. 7. Carburetor out of adjustment. 8. Engine valves out of adjustment. 	<ol style="list-style-type: none"> 1. Clean/replace air filter. 2. Replace spark plug. 3. Recharge or replace battery. 4. Replace fuel filter. 5. Empty fuel tank and refill tank with fresh, clean gasoline. 6. Check all wiring. 7. See "To Adjust Carburetor" in Service and Adjustments section. 8. Contact a Sears or other qualified service center.
Engine will not turn over	<ol style="list-style-type: none"> 1. Clutch/brake pedal not depressed. 2. Attachment clutch is engaged. 3. Weak or dead battery. 4. Blown fuse. 5. Corroded battery terminals. 6. Loose or damaged wiring. 7. Faulty ignition switch. 8. Faulty solenoid or starter. 9. Faulty operator presence switch(es). 	<ol style="list-style-type: none"> 1. Depress clutch/brake pedal. 2. Disengage attachment clutch. 3. Recharge or replace battery. 4. Replace fuse. 5. Clean battery terminals. 6. Check all wiring. 7. Check/replace ignition switch. 8. Check/replace solenoid or starter. 9. Contact a Sears or other qualified service center.
Engine clicks but will not start	<ol style="list-style-type: none"> 1. Weak or dead battery. 2. Corroded battery terminals. 3. Loose or damaged wiring. 4. Faulty solenoid or starter. 	<ol style="list-style-type: none"> 1. Recharge or replace battery. 2. Clean battery terminals. 3. Check all wiring. 4. Check/replace solenoid or starter.

TROUBLESHOOTING CHART:

See appropriate section in manual unless directed to Sears service center

PROBLEM	CAUSE	CORRECTION
Loss of power	<ol style="list-style-type: none"> 1. Cutting too much grass/too fast. 2. Throttle in "CHOKE" position. 3. Build-up of grass, leaves and trash under mower. 4. Dirty air filter. 5. Low oil level/dirty oil. 6. Faulty spark plug. 7. Dirty fuel filter. 8. Stale or dirty fuel. 9. Water in fuel. 10. Spark plug wire loose. 11. Dirty engine air screen/fins. 12. Dirty/clogged muffler. 13. Loose or damaged wiring. 14. Carburetor out of adjustment. 15. Engine valves out of adjustment. 	<ol style="list-style-type: none"> 1. Raise cutting height/reduce speed. 2. Adjust throttle control. 3. Clean underside of mower housing. 4. Clean/replace air filter. 5. Check oil level/change oil. 6. Clean and regap or change spark plug. 7. Replace fuel filter. 8. Empty fuel tank and refill tank with fresh, clean gasoline. 9. Empty fuel tank and carburetor, refill tank with fresh gasoline and replace fuel filter. 10. Connect and tighten spark plug wire. 11. Clean engine air screen/fins. 12. Clean/replace muffler. 13. Check all wiring. 14. See "To Adjust Carburetor" in Service and Adjustments section. 15. Contact a Sears or other qualified service center.
Excessive vibration	<ol style="list-style-type: none"> 1. Worn, bent or loose blade. 2. Bent blade mandrel. 3. Loose/damaged part(s). 	<ol style="list-style-type: none"> 1. Replace blade. Tighten blade bolt. 2. Contact a Sears or other qualified service center. 3. Tighten loose part(s). Replace damaged parts.
Engine continues to run when operator leaves seat with attachment clutch engaged	<ol style="list-style-type: none"> 1. Faulty operator-safety presence control system. 	<ol style="list-style-type: none"> 1. Check wiring, switches and connections. If not corrected, contact Sears or other qualified service center.
Poor cut - uneven	<ol style="list-style-type: none"> 1. Worn, bent or loose blade. 2. Mower deck not level. 3. Buildup of grass, leaves, and trash under mower. 4. Bent blade mandrel. 5. Clogged mower deck vent holes from buildup of grass, leaves, and trash around mandrels. 	<ol style="list-style-type: none"> 1. Replace blade. Tighten blade bolt. 2. Level mower deck. 3. Clean underside of mower housing. 4. Contact a Sears or other qualified service center. 5. Clean around mandrels to open vent holes.

TROUBLESHOOTING CHART:

See appropriate section in manual unless directed to Sears service center

PROBLEM	CAUSE	CORRECTION
Mower blades will not rotate	<ol style="list-style-type: none"> 1. Obstruction in clutch mechanism. 2. Worn/damaged mower drive belt. 3. Frozen idler pulley. 4. Frozen blade mandrel. 	<ol style="list-style-type: none"> 1. Remove obstruction. 2. Replace mower drive belt. 3. Replace idler pulley. 4. Contact a Sears or other qualified service center.
Poor grass discharge	<ol style="list-style-type: none"> 1. Engine speed too slow. 2. Travel speed too fast. 3. Wet grass. 4. Mower deck not level. 5. Low/uneven tire air pressure. 6. Worn, bent or loose blade. 7. Buildup of grass, leaves and trash under mower. 8. Mower drive belt worn. 9. Blades improperly installed. 10. Improper blades used. 11. Clogged mower deck vent holes from buildup of grass, leaves, and trash around mandrels. 	<ol style="list-style-type: none"> 1. Place throttle control in "FAST" position. 2. Shift to slower speed. 3. Allow grass to dry before mowing. 4. Level mower deck. 5. Check tires for proper air pressure. 6. Replace/sharpen blade. Tighten blade bolt. 7. Clean underside of mower housing. 8. Replace mower drive belt. 9. Reinstall blades sharp edge down. 10. Replace with blades listed in this manual. 11. Clean around mandrels to open vent holes.
Headlight(s) not working (if so equipped)	<ol style="list-style-type: none"> 1. Switch is "OFF". 2. Bulb(s) or lamp(s) burned out. 3. Faulty light switch. 4. Loose or damaged wiring. 5. Blown fuse. 	<ol style="list-style-type: none"> 1. Turn switch "ON". 2. Replace bulb(s) or lamp(s). 3. Check/replace light switch. 4. Check wiring and connections. 5. Replace fuse.
Battery will not charge	<ol style="list-style-type: none"> 1. Bad battery cell(s). 2. Poor cable connections. 3. Faulty regulator (if so equipped). 4. Faulty alternator. 	<ol style="list-style-type: none"> 1. Replace battery. 2. Check/clean all connections. 3. Replace regulator. 4. Replace alternator.
Engine "backfires" when turning engine "OFF"	<ol style="list-style-type: none"> 1. Engine throttle control not set at "SLOW" position for 30 seconds before stopping engine. 	<ol style="list-style-type: none"> 1. Move throttle control to "SLOW" position and allow to idle for 30 seconds before stopping engine.

TRACTOR - - MODEL NUMBER 917.273471

SCHEMATIC

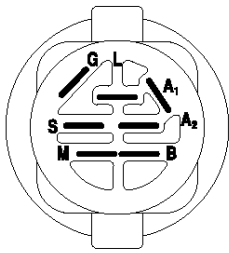
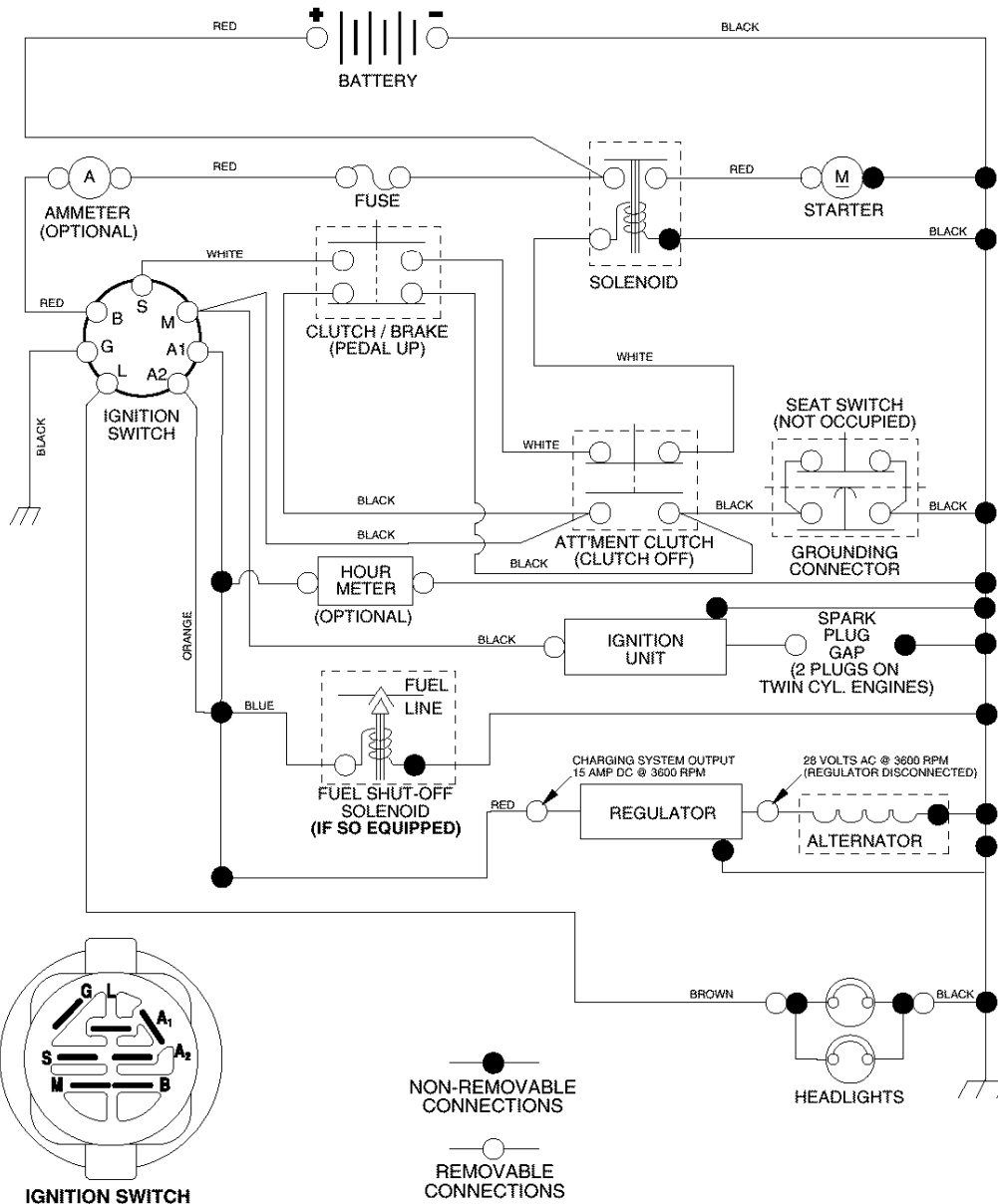

IGNITION SWITCH

POSITION	CIRCUIT	"MAKE"
OFF	M+G+A1	NONE
RUN/LIGHT	B+A1	A2+L
RUN	B+A1	NONE
START	B + S + A1	NONE

WIRING INSULATED CLIPS

NOTE: IF WIRING INSULATED CLIPS WERE REMOVED FOR SERVICING OF UNIT, THEY SHOULD BE REPLACED TO PROPERLY SECURE YOUR WIRING.

REPAIR PARTS

TRACTOR - - MODEL NUMBER 917.273471

ELECTRICAL

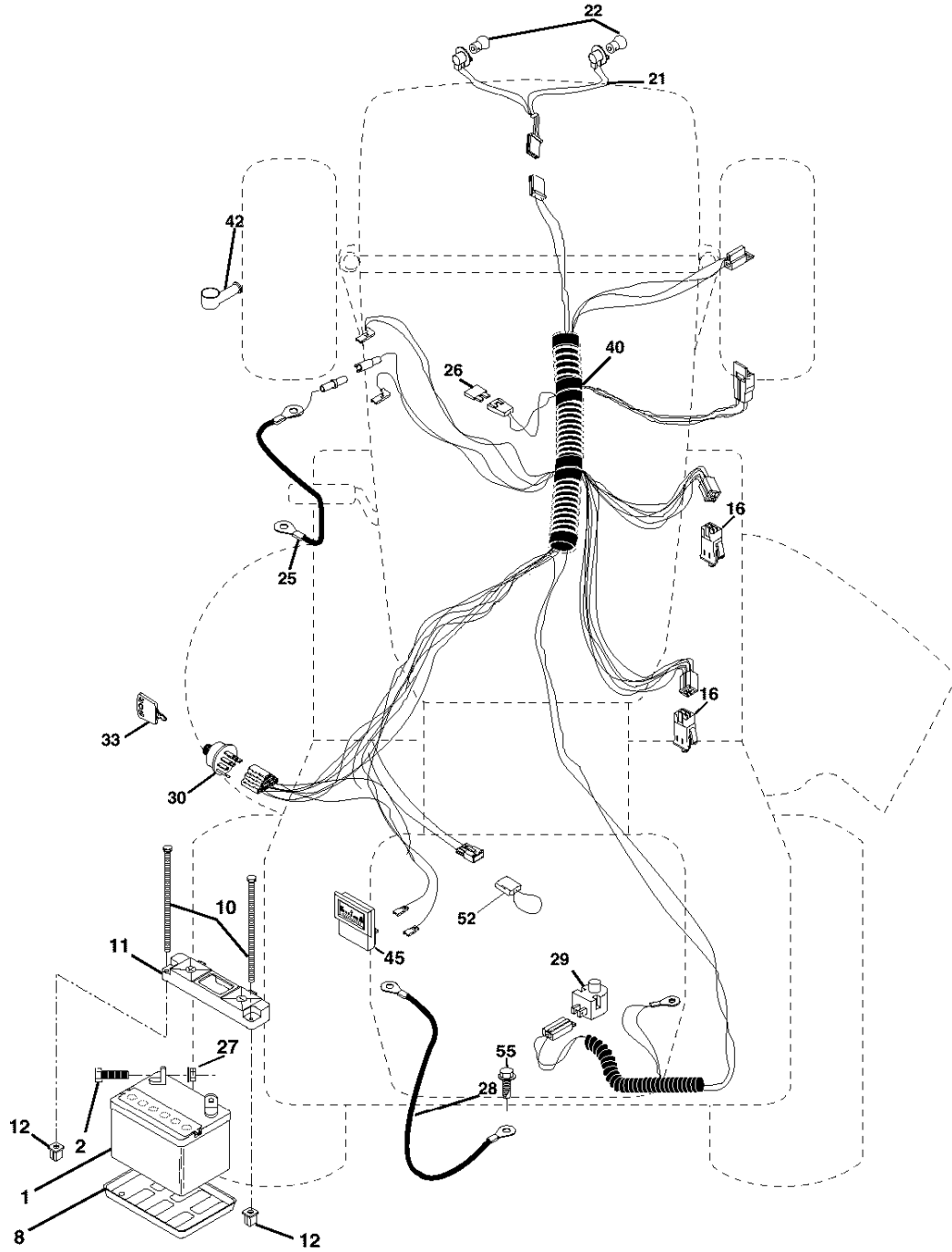

ELECTRICAL

TRACTOR - - MODEL NUMBER 917.273471

KEY NO.	PART NO.	DESCRIPTION
1	144927	Battery
2	74760412	Bolt Hex Hd 1/4-20 Unc x 3/4
8	7603J	Case Battery
10	145211	Bolt, Btr Front 1/4-20 x 7-1/2
11	150109	Holddown Battery Front Mount
12	145769	Nut, Push Nylon Battery Front 1/4
16	176138	Switch, Interlock Push-In
21	183759	Harness Light Socket (W/4152j)
22	4152J	Bulb Light #1156
25	178909	Cable Battery 6 Ga. Red 25"
26	175158	Fuse
27	73510400	Nut Keps Hex 1/4-20 Unc
28	145491	Cable Ground
29	121305X	Switch Seat
30	175566	Switch Ign
33	140403	Key Molded Craftsman
40	187576	Harness Ign
42	154336	Cover Terminal
45	122822X	Ammeter Rectangular 15 Amp
52	141940	Protection Wire Loop
55	17490508	Screw Thdrol 5/16-18 x 1/2

NOTE: All component dimensions given in U. S.
inches 1 inch = 25.4 mm

TRACTOR - - MODEL NUMBER 917.273471

CHASSIS AND ENCLOSURES

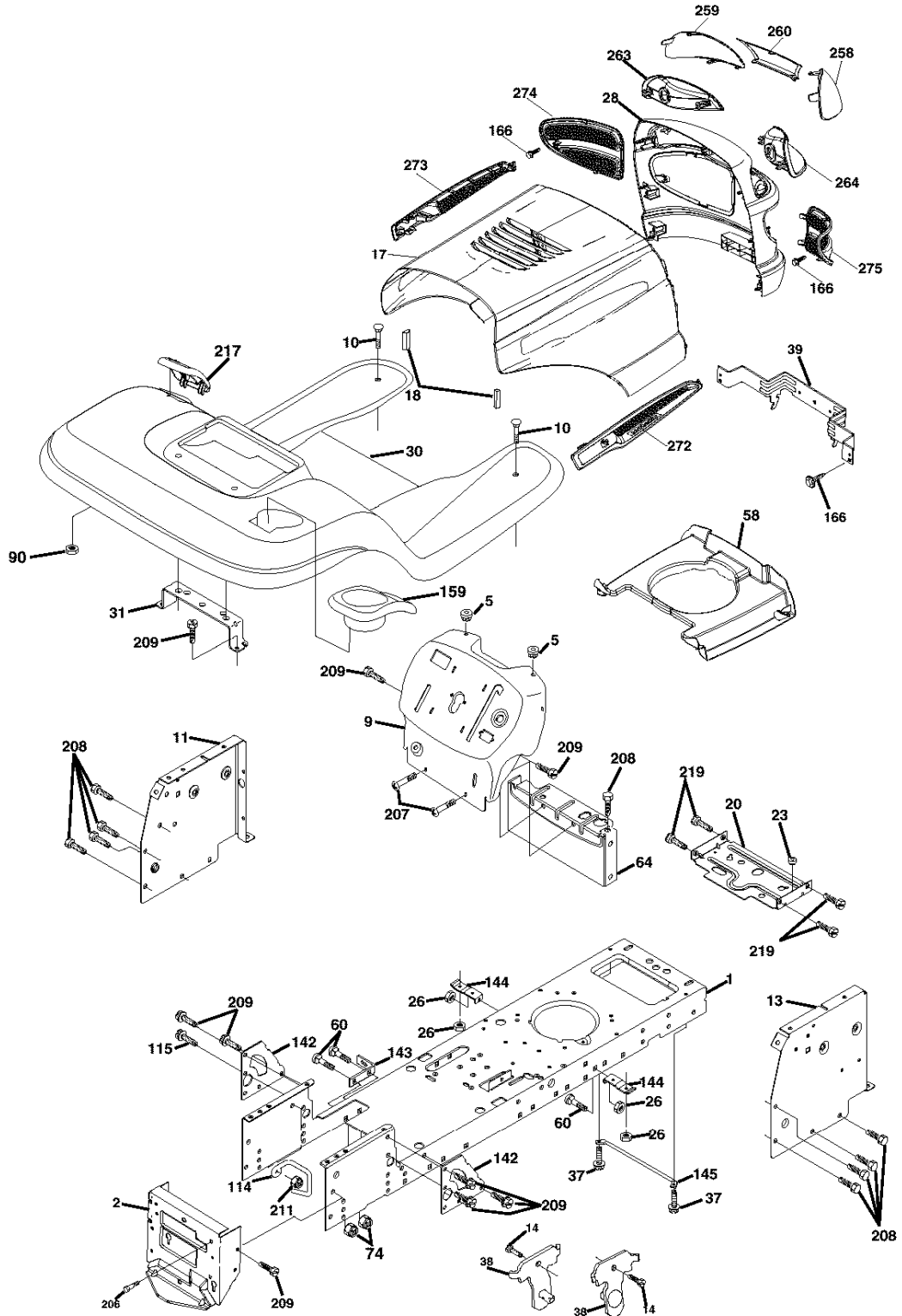

chassis-Laser -lt.stlt_25



TRACTOR - - MODEL NUMBER 917.273471
CHASSIS AND ENCLOSURES

KEY PART NO. NO.	DESCRIPTION	KEY PART NO. NO.	DESCRIPTION
1	174619 Chassis Assembly	143	186689 Bracket Swaybar Chassis
2	176554 Drawbar	144	175582 Bracket Pnt Footrest STLT
5	155272 Bumper Hood/Dash	145	156524 Rod Pivot Chassis/Hood
9	168337X013 Dash	159	179950X428 Cupholder
10	STD533710 Bolt, Carriage 3/8-16 x 1	166	171875 Screw Hwhd Hi-Lo #13-16 x 3/4
11	174996 Panel, Dash, L.H.	206	170165 Bolt Shoulder 5/16-18 TT
13	172105X010 Panel, Dash, R.H.	207	17670508 Screw Thdrol 5/16-18 x 1/2
14	17490608 Screw Thdrol 3/8-16 x 1/2	208	17670608 Screw Thdrol 3/8-16 x 1/2
17	184272X615 Hood Assembly	209	17000612 Screw Hex Wsh Thdr 3/8-16 x 3/4
18	184921 Bumper Hood	211	145212 Nut Hexflange Lock
20	180679 Plate Mtg Battery Fuel Tank	217	179132X428 Console Fuel Window
23	124028X Bushing, Snap, Nylon, Fuel Line	219	17000512 Screw 5/16-18 x 3/4
26	STD541437 Locknut, Hex, w/Insert 3/8-16 Unc	258	184264X599 Lens Laser RH
28	184259 Grille/Lens Asm	259	184263X599 Lens Laser LH
30	179131X615 Fend/Ftrest	260	184262X428 Cover Lens Laser
31	139976 Bracket, Fender Support	263	184265 Bezel Grille LH
37	17490508 Screw Thdrol 5/16-18 x 1/2	264	184266 Bezel Grille RH
38	175710 Pivot Bracket Assembly	272	185922X428 Vent Hood Laser III LH
39	174714 Bracket Pivot	273	185923X428 Vent Hood Laser III RH
58	187154 Air Duct	274	184260X428 Insert Grille LH
60	STD533707 Bolt Rdhd Sqnk 3/8-16 Unc x 3/4	275	184261X428 Insert Grille RH
64	154798 Dash Lower STLT	--	5479J Plug BTN .359 Dia.
74	STD541437 Nut Crownlock 3/8-16 Unc		
90	124346X Nut Self-Thd Wsh-Hd 1/4		
114	158112 Keeper Belt Rear Lh Stl		
115	17490620 Screw 3/8-16 x 1-1/4		
142	175702 Plate Reinforcement STLT		

NOTE: All component dimensions given in U. S. inches 1 inch = 25.4 mm



TRACTOR - - MODEL NUMBER 917.273471

GROUND DRIVE

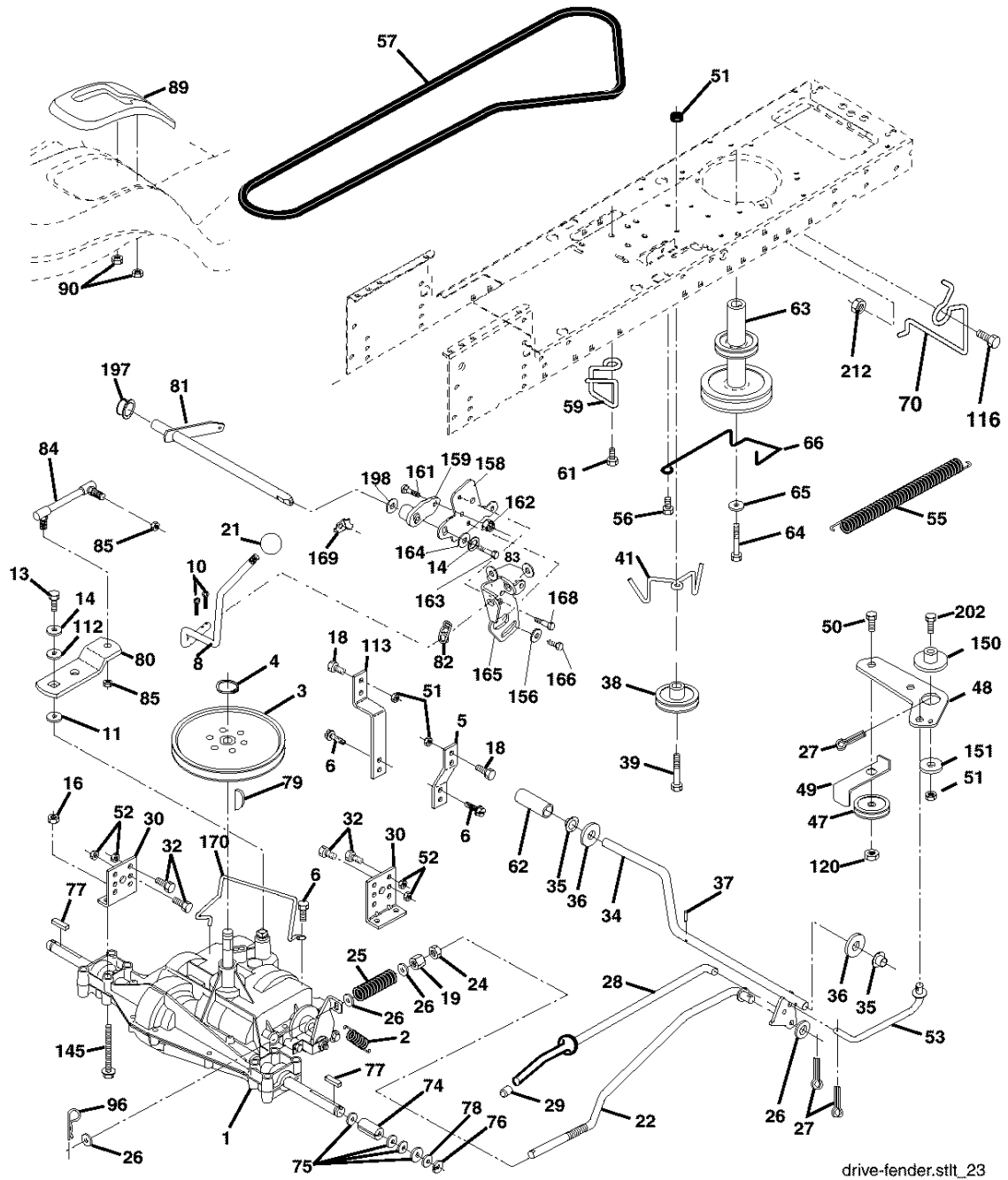

drive-fender.stlt_23



TRACTOR - - MODEL NUMBER 917.273471

GROUND DRIVE

KEY NO.	PART NO.	DESCRIPTION	KEY NO.	PART NO.	DESCRIPTION
1	-----	Transaxle (See Breakdown) Peerless 206-545C	64	173937	Bolt, Hex 7/16-20 x 4 Grade 5
2	146682	Spring, Return, Brake	65	STD551143	Washer
3	123666X	Pulley, Transaxle	66	154778	Keeper, Belt, Engine, Fool-Proof
4	12000028	Ring, Retainer	70	134683	Guide, Mower Drive Belt, R.H.
5	121520X	Strap, Torque	74	137057	Spacer, Axle
6	17060512	Screw 5/16-18 x 3/4	75	121749X	Washer 25/32 x 1-1/4 x 16 Ga.
8	165866	Rod Shifter Fender STLT	76	STD581075	E-Ring
10	STD561210	Pin, Cotter	77	123583X	Key, Square 2.0 x .1845/.1865
11	105701X	Washer, Shift Plate	78	121748X	Washer 25/32 x 1-5/8 x 16 Ga
13	74550412	Bolt 1/4-28 Unf W/Patch Gr. 8	79	STD580025	Key Woodruff
14	10040400	Washer Lock Hvy Helical	80	145090	Arm, Shift
16	73800500	Nut Lock Hx W/lins 5/16-18	81	165592	Shaft Asm Cross Tapered 650 20
18	STD523710	Bolt Fin Hex 3/8-16 Unc x 1 Gr 5	82	165711	Spring, Torsion
19	STD541437	Nut	83	19171216	Washer 17/32 x 3/4 x 16 Ga.
21	106933X	Knob	84	166231	Link Transaxle
22	130804	Rod, Brake	85	150360	Nut, Nylock
24	STD541237	Nut	89	158391X428	Console, Shift, STLT
25	106888X	Spring, Brake Rod	90	124346X	Nut, Self-Thding, Wsh Hd 1/4
26	STD551037	Washer	96	STD624003	Retainer Spring 1"
27	STD561210	Pin	112	19091210	Washer 9/32 x 3/4 x 10 Gauge
28	175765	Rod, Parking Brake	113	127285X	Strap Torque 90 Degrees
29	71673	Cap, Parking Brake	116	72140608	Bolt Rdhd Sqneck 3/8-16 x 1
30	169592	Bracket, Transaxle	120	73900600	Nut Lock Flg. 3/8-16
32	STD523107	Bolt	145	74490540	Bolt, Hex Flghd 5/16-18 Gr. 5
34	175578	Shaft Assembly, Foot Pedal	150	175456	Spacer Retainer
35	120183X	Bearing, Nylon	151	19133210	Washer 13/32 x 2 x 10 Ga.
36	STD551062	Washer	156	166002	Washer Srrted 5/16 ID x 1.125
37	STD571810	Roll Pin	158	165589	Bracket Shift Mount
38	179114	Pulley, Composite, Flat	159	183900	Hub Shift
39	74760648	Bolt, Fin Hex 3/8-16 x 3	161	72140406	Bolt Rdhd Sqnk 1/4-20 x 3/4 Gr.5
41	175556	Keeper, Belt, Idler	162	73680400	Nut Crownlock 1/4-20 Unc
47	127783	Pulley, Idler, V-Groove, Plastic	163	74780416	Bolt Hex Fin 1/4-20 Unc x 1 Gr 5
48	154407	Bellcrank Clutch Grnd Drv Stl	164	19091010	Washer 5/8 x .281 x 10 Ga
49	123205X	Retainer, Belt	165	165623	Bracket Pivot Lever
50	72110612	Bolt Carr. Sh. 3/8-16 x 1-1/2 Gr. 5	166	166880	Screw 5/16-18 x 5/8
51	STD541437	Nut Crown Lock 3/8-16 Unc	168	165492	Bolt Shoulder 5/16-18 x .561
52	STD541431	Nut Crown Lock 5/16-18 Unc	169	165580	Plate Fastening Lt
53	105710X	Link, Clutch	170	178394	Keeper Belt Transaxle Gear
55	105709X	Spring, Clutch Return	197	169613	Nyliner Snap-In
56	17060620	Screw 3/8-16 x 1-1/4	198	169593	Washer Nyliner
57	130801	V-Belt, Ground Drive	202	72110614	Bolt Carr. SH 3/8-16 x 1-3/4 Gr. 5
59	169691	Keeper, Belt, Center Span	212	145212	Nut Hex Flg. Lock
61	17120614	Screw 3/8-16 x .875			
62	8883R	Cover, Pedal			
63	175410	Pulley, Engine			

NOTE: All component dimensions given in U. S. inches 1 inch = 25.4 mm

TRACTOR - - MODEL NUMBER 917.273471

STEERING

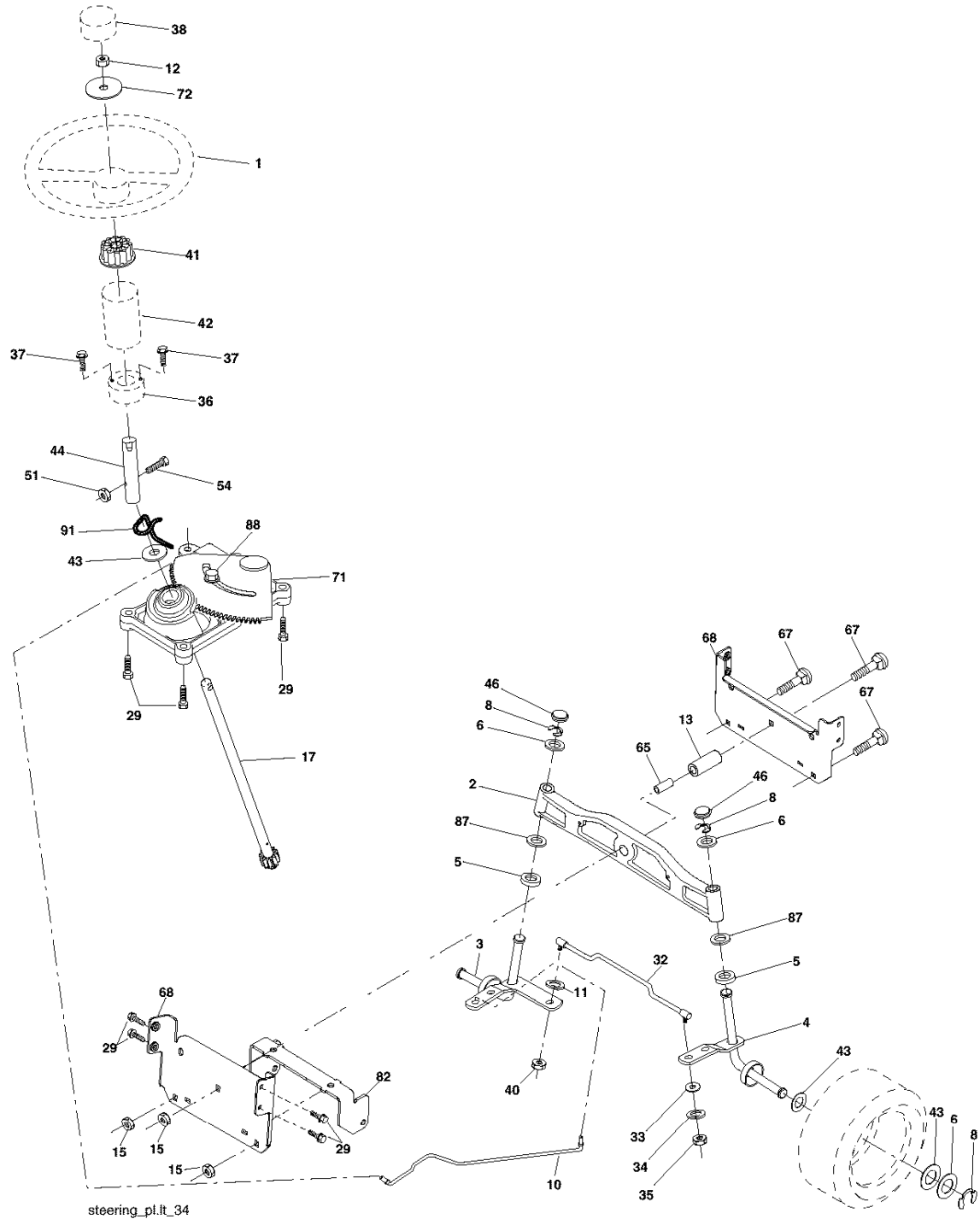

STEERING

TRACTOR - - MODEL NUMBER 917.273471

KEY NO.	PART NO.	DESCRIPTION
1	159944X428	Steering Wheel
2	184706	Axle Assembly
3	169840	Spindle Assembly, L.H.
4	169839	Spindle Assembly, R.H.
5	6266H	Bearing, Race, Thrust, Hardened
6	121748X	Washer 25/32 x 1-5/8 x 16 Gauge
8	12000029	Ring, Klip
10	175121	Draglink
11	STD551137	Washer, Lock
12	73940800	Nut Hex Jam Toplock 1/2-20 Unf
13	136518	Spacer, Bearing, Axle
15	145212	Nut, Hexflange Lock
17	180641	Shaft Assembly, Steering
29	17000612	Screw 3/8-16 x 3/4
32	171888	Rod, Tie
33	19111216	Washer 11/32 x 3/4 x 16 Ga.
34	10040500	Washer Lock 5/16
35	73540500	Crownlock Nut 5/16-24 Unf
36	155099	Bushing, Steering
37	152927	Screw
38	159946X428	Insert, Steering Wheel
39	19182411	Washer 9/16 ID x 1-1/2 OD 11 Ga.
40	STD541537	Gripco Nut
41	159945	Adaptor, Steering Wheel
42	145054X428	Boot, Steering Shaft
43	121749X	Washer 25/32 x 1-1/4 x 16 Ga.
44	180640	Extension Shaft Steering
46	184946X505	Cap, Spindle
51	73540400	Nut Crownlock 1/4-28
54	71130420	Bolt Hex 1/4-28 Unf x 1-1/4 Gr. 8
65	160367	Spacer Brace Axle
67	72110618	Bolt RDHD SQNK 3/8-16 x 2-1/4
68	169827	Axle, Brace
71	175146	Steering Asm
82	169835	Bracket Susp Chassis Front
87	173966	Washer Flat .781 x 1-1/2 x .14
88	175118	Bolt shoulder 7/16-20
91	175553	Clip Steering

NOTE: All component dimensions given in U. S.
inches 1 inch = 25.4 mm

TRACTOR - - MODEL NUMBER 917.273471

ENGINE

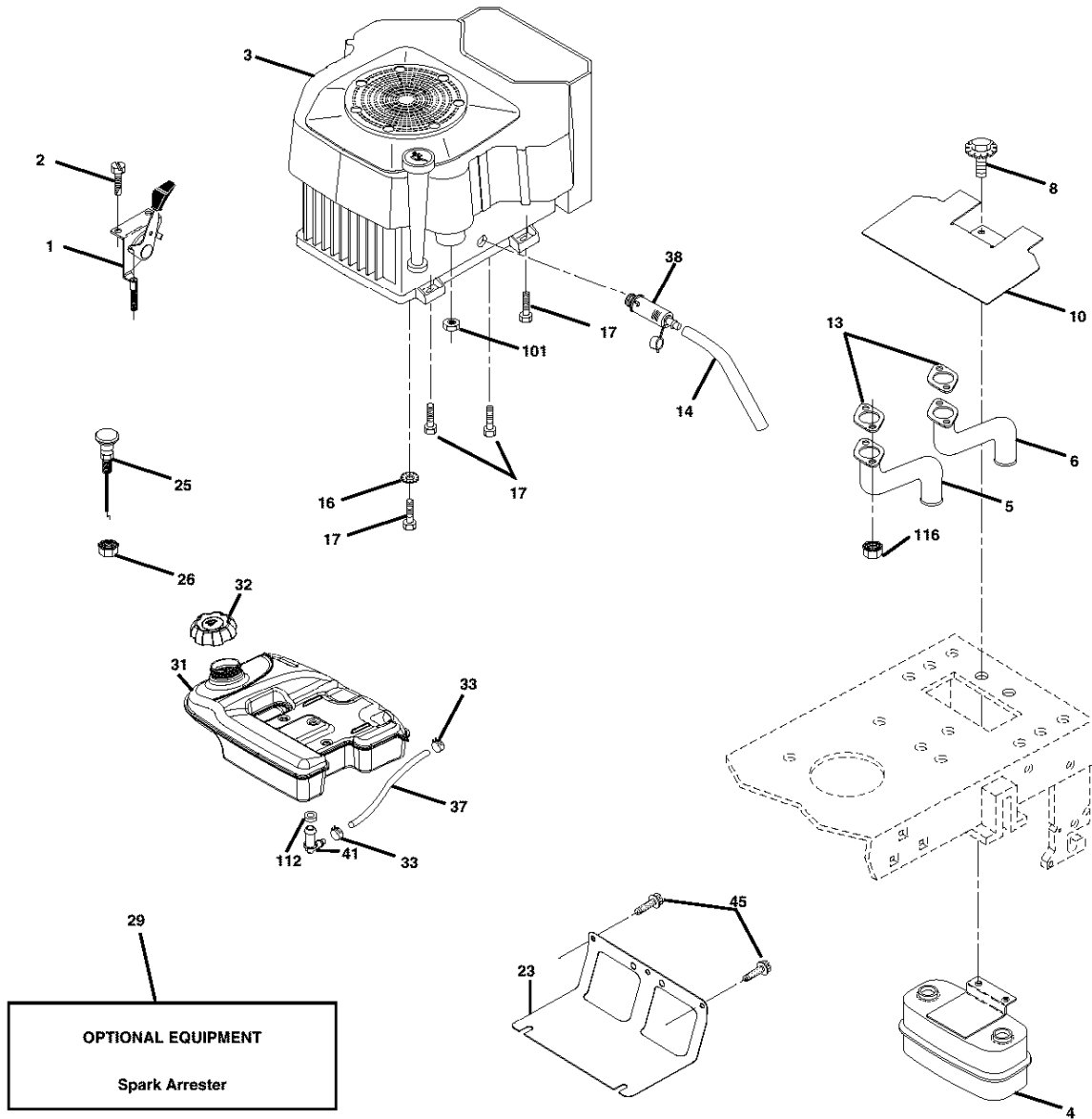

engine-ko.twin_15



ENGINE**TRACTOR - - MODEL NUMBER 917.273471**

KEY NO.	PART NO.	DESCRIPTION
1	187065	Control, Throt Paddle
2	17720408	Screw, Hex Thd Cut 1/4-20 x 1/2
3	-----	Engine, Kohler, (See Breakdown) No. CV624-65596
4	149723	Muffler Exhaust
5	146699	Exhaust Asm. Left
6	146700	Exhaust Asm. Right
8	171877	Bolt 5/16-18 Unc x 3/4 W/Sems
10	146629	Heat Shield Lt
13	24-041-49	Gasket, Muffler
14	148456	Tube Drain Oil Easy
16	STD551237	Washer Lock Ext Tooth 3/8
17	17060624	Screw 3/8-16 x 1-1/2
23	169837	Shield, Brn/Dbr Guard
25	145996	Control Choke
26	73920600	Nut Keps 3/8-24 Unf
29	137180	Arrestor, Spark
31	179022	Tank, Fuel
32	179124X428	Cap Fuel Guage
33	123487X	Clamp, Hose
37	8543R	Line, Fuel
38	181654	Plug, Oil Drain Easy
41	139277	Stem Tank Fuel
45	17000612	Screw Hex Wsh 3/8-16 x 3/4
101	M73030800	Nut Flange M8-1.25
112	3645J	Bushing
116	184362	Nut Hex Flange Toplock M8-1.25

NOTE: All component dimensions given in U. S.
inches 1 inch = 25.4 mm

TRACTOR - - MODEL NUMBER 917.273471
SEAT ASSEMBLY

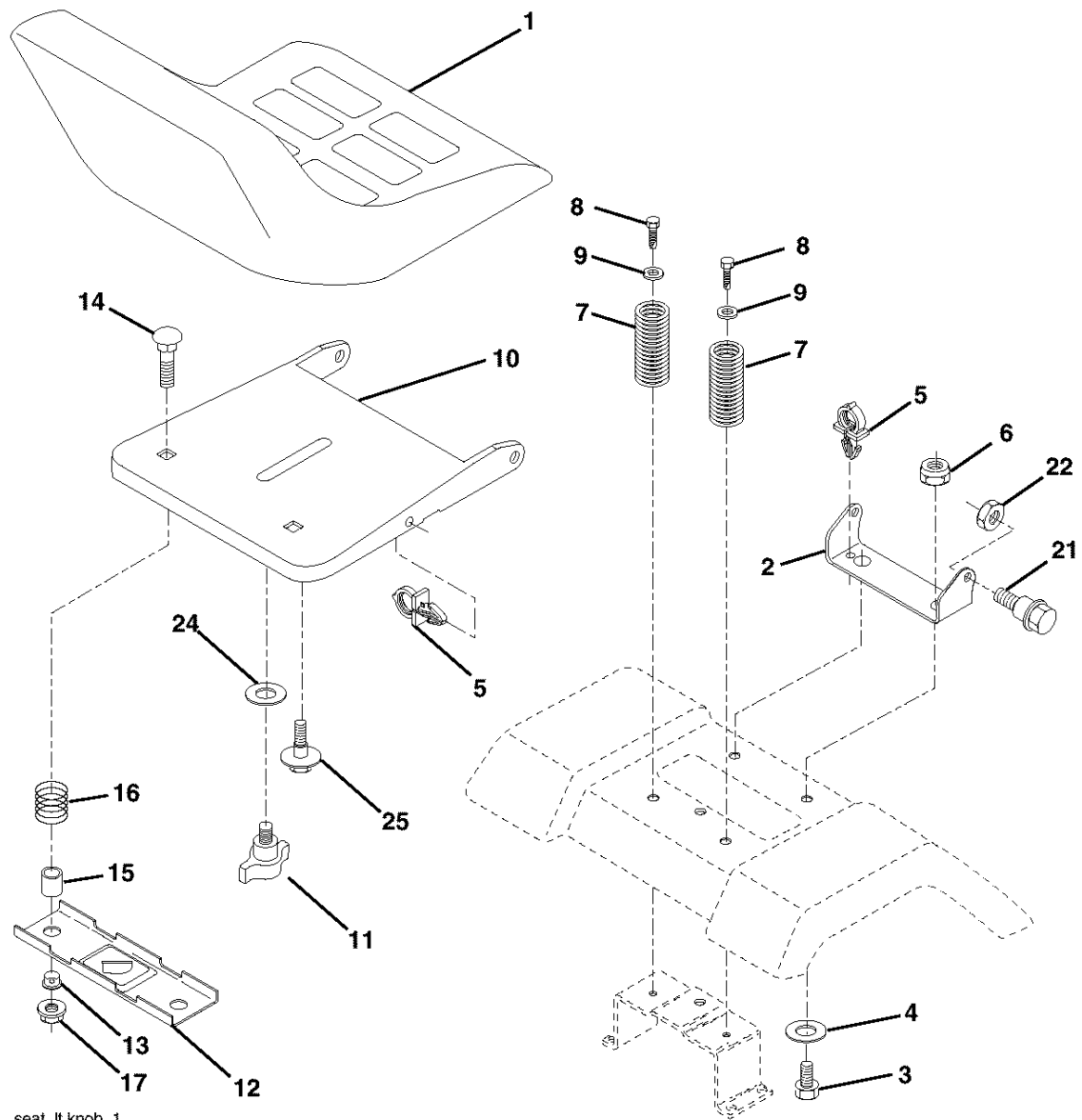

seat_lt.knob_1

KEY PART NO.	NO.	DESCRIPTION
1	187813	Seat
2	140551	Bracket, Pivot, Seat
3	71110616	Bolt
4	19131610	Washer 13/32 x 1 x 10 Gauge
5	145006	Clip, Push-In Hinged
6	STD541437	Nut
7	124181X	Spring, Seat
8	17000616	Screw 3/8-16 x 1-1/2
9	19131614	Washer 13/32 x 1 x 14 Gauge
10	182493	Pan, Seat
11	166369	Knob Seat
12	121246X	Bracket, Switch Mounting

KEY PART NO.	NO.	DESCRIPTION
13	121248X	Bushing, Snap
14	72050412	Bolt, Carriage 1/4-20 x 1-1/2
15	134300	Spacer, Split .28 x .88
16	121250X	Spring
17	123976X	Locknut, Flange 1/4 Grade 5
21	171852	Bolt, Shoulder 5/16-18 Unc
22	STD541431	Nut
24	19171912	Washer 17/32 x 1-3/16 x 12 Ga.
25	127018X	Bolt Shoulder 5/16-18 x.62

NOTE: All component dimensions given in U.S. inches 1 inch = 25.4 mm

TRACTOR - - MODEL NUMBER 917.273471

DECALS

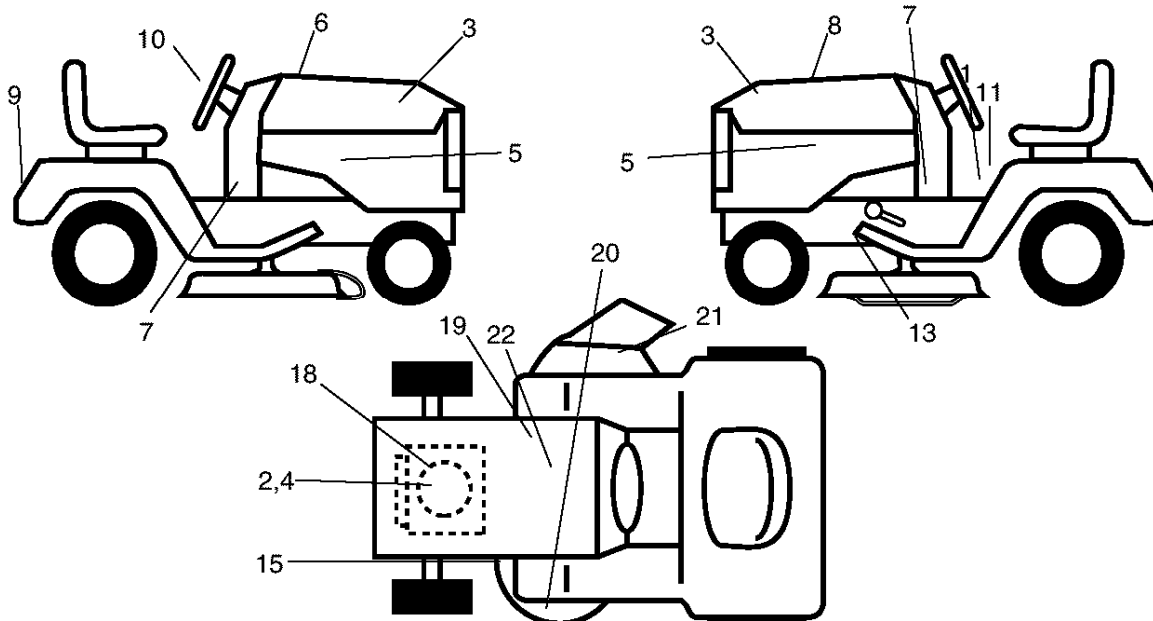

KEY PART NO. NO.

KEY PART NO.	NO.	DESCRIPTION
1	156439	Decal, Fender Danger Sears
2	177915	Decal, Engine
3	186366	Decal, Hood, R.H. /L.H.
4	177918	Decal, V-Twin
5	186367	Decal, Hood Side Panel
6	133644	Decal, Maintenance
7	177967	Decal, Lower Dash
8	187029	Decal, Rplcmnt
9	186572	Decal, Fender, Craftsman White
10	164065	Decal, Strng Whl Domed
11	156368	Decal, Fender STLTL Oper Inst E/S

KEY PART NO. NO.

KEY PART NO.	NO.	DESCRIPTION
13	146046	Decal, V-Belt Dr Sch Tractor
15	160396	Decal, Mower Drive Schematic
18	177914	Decal, Engine, Kohler
19	138047	Decal, Battery Diehard Sears
20	172331	Decal, Deck Sears
21	179128	Decal, Deck
22	149516	Decal, Battery
--	138311	Decal, Lift Handle
--	184310X428	Pad Footrest LH STLTL
--	184311X428	Pad Footrest RH STLTL
--	187040	Owner's Manual, English
--	187041	Owner's Manual, Spanish

WHEELS AND TIRES

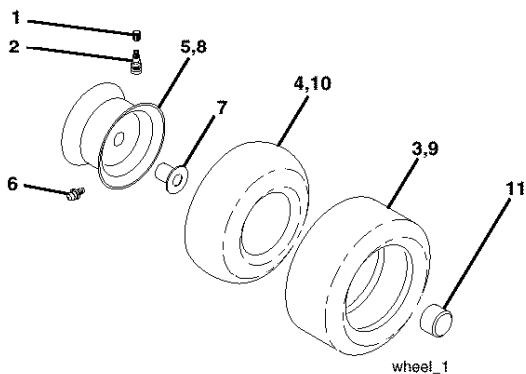

KEY PART NO. NO.

KEY PART NO.	NO.	DESCRIPTION
1	59192	Valve Cap, Tire
2	65139	Stem, Valve
3	177750	Tire, Front
4	59904	Tube, Front Tire (Not Provided, Service Item Only)
5	106732X624	Rim, Front
6	278H	Fitting, Grease (Front Wheel Only)
7	9040H	Bearing, Flange (Front Wheel Only)
8	106108X624	Rim, Rear
9	177751	Tire, Rear
10	7152J	Tube, Rear Tire (Not Provided, Service Item Only)
11	104757X428	Cap, Axle
--	144334	Sealant, Tire 10 oz.

NOTE: All component dimensions given in U. S. inches 1 inch = 25.4 mm

TRACTOR - - MODEL NUMBER 917.273471
LIFT ASSEMBLY

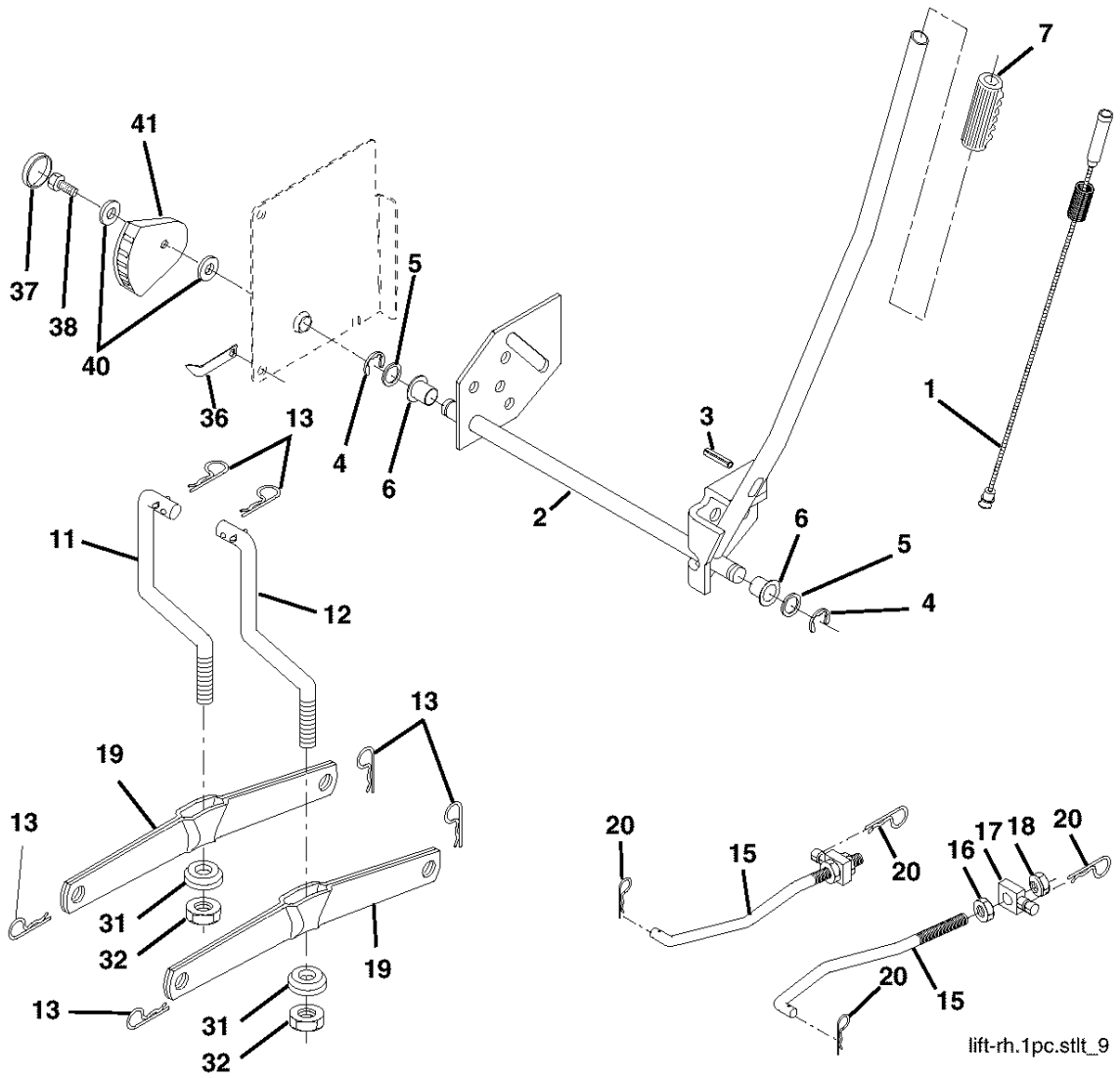

lift-rh.1pc.stlt_9



LIFT ASSEMBLY **TRACTOR - - MODEL NUMBER 917.273471**

KEY NO.	PART NO.	DESCRIPTION
1	159460	Wire Asm Inner/Sprg W/plunger LT
2	159471	Shaft Asm Lift RH w/Inf
3	105767X	Pin Groove 1 500 Zinc
4	12000002	E Ring #5133-62
5	19211621	Washer 21/32 x 1 x 21 Ga
6	120183X	Bearing Nylon Blk 629 Id
7	125631X	Grip Handle
8	122365X	Button Plunger Yellow
11	139865	Link Lift LH Fixed Length
12	139866	Link Lift RH Fixed Length
13	4939M	Retainer Spring
15	173288	Link Front
16	73350800	Nut Jam Hex 1/2-13 Unc
17	175689	Trunnion Blk Zinc
18	73800800	Nut Lock w/Wsh 1/2-13 Unc
19	139868	Arm Suspension Rear
20	163552	Retainer Spring
31	169865	Bearing Pvt Lift
32	73540600	Nut Crownlock 3/8 - 24
36	155097	Pointer Height Indicator
37	123935X	Plug Hole Blk 1.485/1.515 Dia.
38	17060516	Screw Thdrol 5/16-18 x 1
40	19112410	Washer 11/32 x 1-1/2 10 Ga.
41	155098	Indicator Height STLT

NOTE: All component dimensions given in U. S.
inches 1 inch = 25.4 mm



TRACTOR - - MODEL NUMBER 917.273471

MOWER DECK

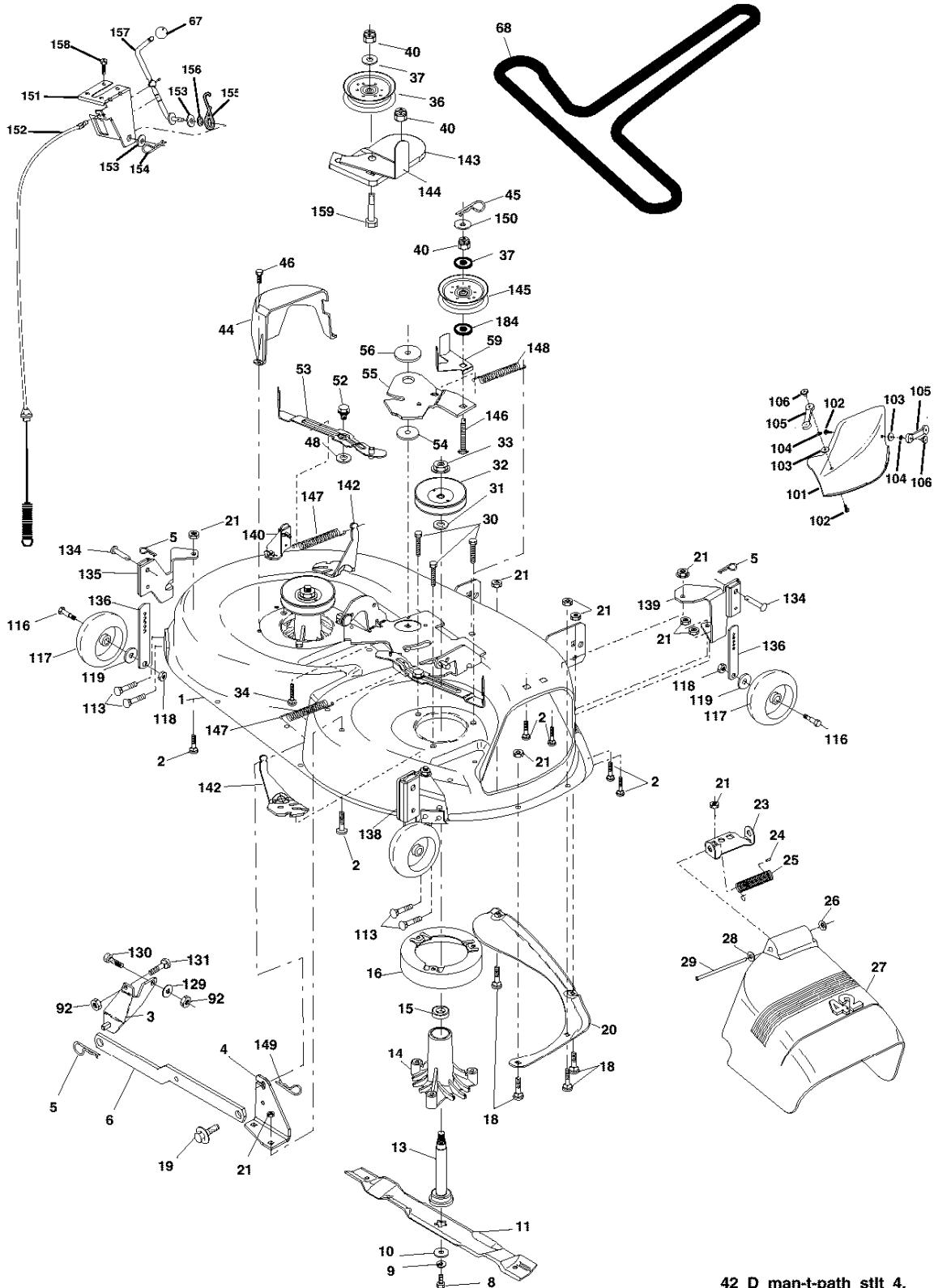

42_D_man-t-path_stlt_4.



TRACTOR - - MODEL NUMBER 917.273471

MOWER DECK

KEY NO.	PART NO.	DESCRIPTION	KEY NO.	PART NO.	DESCRIPTION
1	182032	Mower Deck Assembly, 42"	68	144959	V-Belt
2	STD533107	Bolt	92	STD541437	Nut
3	138017	Bracket Assembly, Sway Bar, Front	101	136420	Mulcher Cover
4	165460	Bracket Sway Bar 38/42" Deck	102	71081010	Screw Pan HD Phillip 10-24 x 5/8
5	STD624008	Retainer Spring	103	19061216	Washer #10
6	178024	Bar Sway Deck	104	STD551110	Washer, Lock
8	850857	Bolt, Hex 3/8-24 x 1.25 Gr. 8	105	160793	Latch Assembly, Bagger
9	STD551137	Washer, Lock	106	2029J	Nut, Weld
10	140296	Washer, Hardened (The following blades are available)	113	17060512	Screw 5/16-18 x 3/4
11	134149	Blade, 42" Mulching Std (For mulching mowers only)	116	184219	Bolt, Shoulder
--	139775	Blade, 42" Mulching Premium (For better wear when mulching)	117	174873	Wheel, Gauge
--	138971	Blade, 42" Hi-Lift (For bagging or discharging)	118	73930600	Nut, Centerlock 3/8-16
13	137645	Shaft Assembly, Mandrel, Vented	119	STD551037	Washer 3/8 x 7/8 x 14 Gauge
14	128774	Housing, Mandrel, Vented	129	19131312	Washer 13/32 x 13/16 x 12 Ga.
15	110485X	Bearing, Ball, Mandrel	130	STD523710	Bolt, Fin Hex 3/8-16 Unc x 1 Gr. 5
16	174493	Stripper, Mower Deck	131	STD533710	Bolt, Rdhd Sqnk 3/8-16 Unc x 1
18	72140506	Bolt, Carriage 5/16-18 x 3/4	134	156941	Pin Head Rivet
19	132827	Bolt, Shoulder	135	159765	Bracket Asm. Whl. Ga. Rear LH
20	159770	Baffle, Vortex	136	155986	Bar Adjusting Gauge Wheel
21	STD541431	Nut Crownlock 5/16-18 Unc	138	159763	Bracket Asm. Whl. Ga. Rear RH
23	177563	Bracket, Deflector	139	159767	Bracket Asm. Whl. Ga. Front RH
24	105304X	Cap, Sleeve	140	159768	Bracket Asm. Whl. Ga. Front LH
25	123713X	Spring, Torsion, Deflector	142	165890	Arm Spring Brake Mower
26	110452X	Nut, Push	143	157109	Bracket Arm Idler 42"
27	130968X428	Shield, Deflector	144	158634	Keeper Belt 42" Clutch Cable
28	19111016	Washer 11/32 x 5/8 x 16 Ga.	145	165888	Pulley Idler Flat
29	131491	Rod, Hinge	146	171977	Bolt Carriage Idler
30	173984	Screw Thdrol Washer Head	147	131335	Spring Extension
31	129963	Washer, Spacer	148	169022	Spring Return Idler
32	153535	Pulley, Mandrel	149	165898	Retainer Spring Yellow Zinc
33	178342	Nut, Toplock, Flanged	150	19091216	Washer 9/32 x 3/4 x 16 Ga.
34	STD533717	Bolt	151	169670	Bracket Clutch
36	131494	Pulley, Idler, Flat	152	169676	Cable Clutch 42 In
37	STD551037	Washer 13/32 x 13/16 x 16 Ga.	153	169674	Washer Flat 3/8" Type B
40	STD541437	Nut Crownlock 3/8-16 Unc	154	169675	Spring Retainer
44	140088	Guard, Mandrel, L.H.	155	169671	Spring Retention Lever
45	STD624003	Retainer	156	169672	Spacer
46	137729	Screw, Thd. Roll 1/4-20 x 5/8	157	169669	Rod Clutch
48	133944	Washer, Hardened	158	17720408	Screw Hex Thd Cut 1/4-20 x 1/2
52	139888	Bolt, Shoulder 5/16-18 Unc	159	STD533717	Bolt Rdhd Sqnk 3/8-16 Unc x 1-3/4
53	184907	Arm Assembly, Pad, Brake	184	19131410	Washer 13/32 x 7/8 x 10 Ga.
54	178515	Washer, Hardened	--	130794	Mandrel Assembly (Includes Housing, Shaf and Shaft Hardware Only-Pulley not included)
55	155046	Arm, Idler	--	186917	Replacement Mower, Complete (Std. Deck - Order separately mulcher cover and gauge wheel components key nos. 101-106 and 5, 116-119, 134-136)
56	165723	Spacer, Retainer			
59	141043	Guard, TUV Idler			
67	149846	Knob Custom Oval			

NOTE: All component dimensions given in U. S. inches 1 inch = 25.4 mm

TRACTOR - - MODEL NUMBER 917.273471
PEERLESS TRANSAXLE--MODEL NUMBER 206-545C

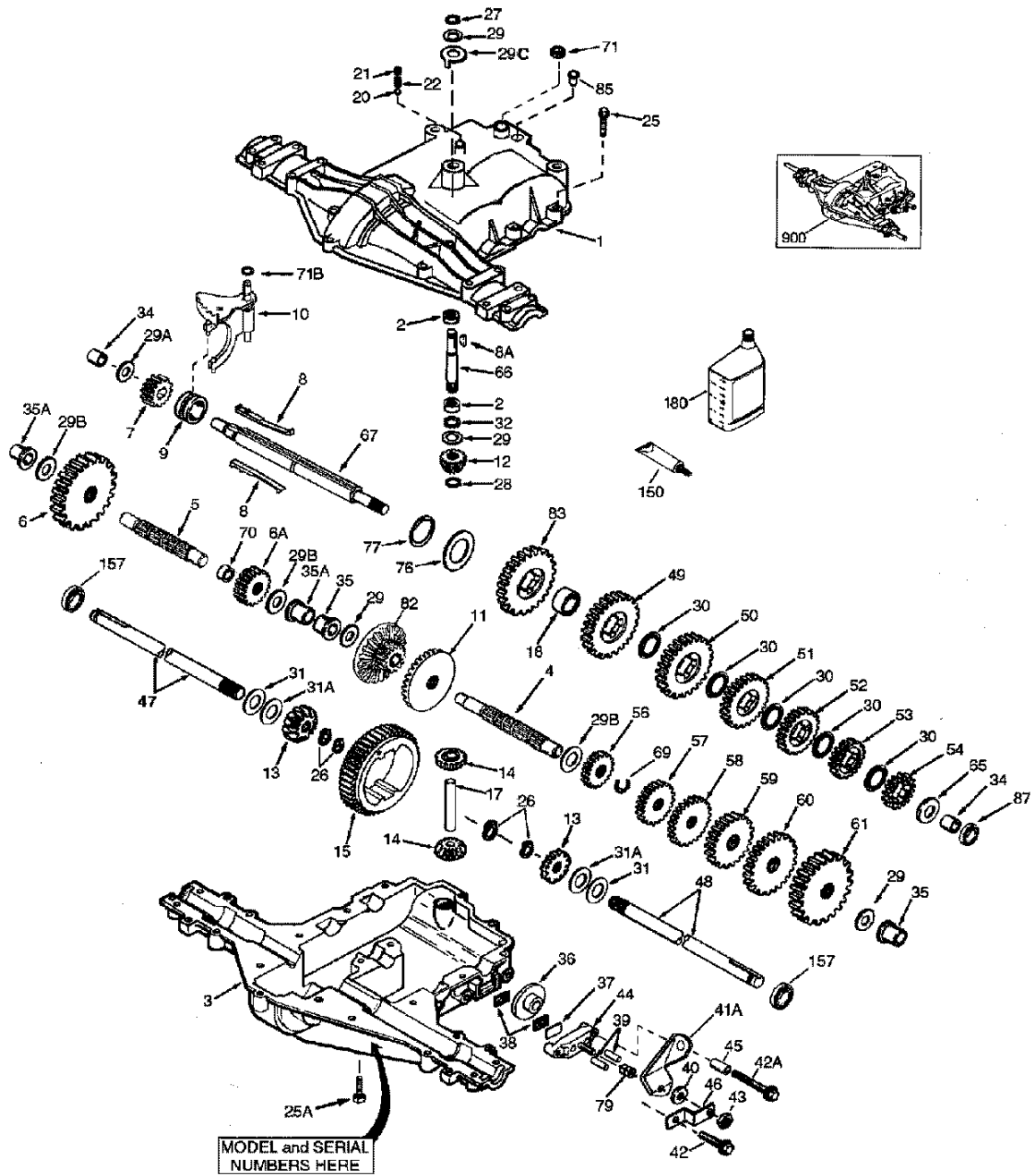

TRACTOR - - MODEL NUMBER 917.273471
PEERLESS TRANSAXLE--MODEL NUMBER 206-545C

KEY NO.	PART NO.	DESCRIPTION	KEY NO.	PART NO.	DESCRIPTION
1	772147	Transaxle Cover	39	786026	Dowel Pin
2	780086A	Needle Bearing 5/8"	40	792076A	Flat Washer .312 ID x .059W
3	770128	Transaxle Case	41A	790079	Brake Lever
4	776395	Countershaft	42	792073A	Screw 1/4 - 20 x 1-1/4"
5	776409	Output Shaft	42A	792085A	Screw 1/4 - 20 x 2 1/4"
6	778364	Spur Gear (38 teeth)	43	792075	Locknut 5 / 16 - 24
6A	778369	Spur Gear (15 teeth)	44	790025	Brake Pad Holder
7	778330	Spur Gear (11 teeth)	45	786066	Spacer .2625 x 1.0
8	792180	Shift Key	46	786086	Brake Lever Bracket
8A	792047	Woodruff Key #9	47	774690	Axle (11-15 / 16" Long)
9	784352	Shift Collar	48	774691	Axle (16 - 1 / 2" long)
10	784378	Shift Rod & Fork	49	778356	Spur Gear (29 teeth)
11	778334	Bevel Gear (30 teeth)	50	778338	Spur Gear (27 teeth)
12	778309	Input Bevel Pinion (13 teeth)	51	778354	Spur Gear (23 teeth)
13	778368	Bevel Gear (13 teeth) (Include. 14)	52	778352	Spur Gear (19 teeth)
14	778368	Bevel Pinion (13 teeth) (Include. 13)	53	778350	Spur Gear (16 teeth)
15	778370	Ring Gear (43 teeth)	54	778346	Spur Gear (15 teeth)
17	786188	Drive Pin	56	778355	Spur Gear (11 teeth)
18	786102	Spacer 1.130 X .695	57	778337	Spur Gear (13 teeth)
20	792077A	Ball 5/16" dia	58	778353	Spur Gear (17 teeth)
21	792078	Set Screw 3/8 - 16 x 3/8"	59	778351	Spur Gear (21 teeth)
22	792079	Spring .310 OD x .625 L	60	778349	Spur Gear (24 teeth)
25	792073A	Screw 1/4 - 20 x 1-1/4"	61	778345	Spur Gear (25 teeth)
25A	792177	Screw 1/4-20 x 1-3/8"	65	780189	Flat Washer .563 ID x .062W
26	792125	Retaining Ring (pkg of 2)	66	776422	Input Shaft
27	792035	Retaining Ring	67	776396	Shifter & Brake Shaft
28	788040	Retaining Ring	69	792170	Retaining Ring
29	780072	Thrust Washer .627 ID x .031W	70	786187	Spacer .890
29A	780160	Thrust Washer .762 ID x .031W	71	788069	Square Cut Ring
29B	780051	Thrust Washer .762 ID x .031W	71B	788092	"O" Ring
29C	780199	Anti-Rotation Washer .632	76	780090	Flat Washer 1.128 ID x .058W
30	780108	Cup Washer 1.127 ID x .032W	77	788078A	Inverted Retaining Ring
31	780001	Flat Washer .750 ID x .056W (Use As Needed)	79	792144	Spring .430 OD x .5000 L
31A	780195	Flat Washer .750 ID x .062W	82	778333	Bevel & Spur Gear (30 & 13 teeth)
32	788083	Oil Seal 5/8"	83	778338	Spur Gear (27 teeth)
34	780194	Bushing .563	85	792154	Oil Fill Plug
35	780193	Flanged Bushing 5 / 8" ID	87	788089A	Oil Seal 9 / 16"
35A	780197	Flanged Bushing .751	150	788093A	Liquid Gasket RTV Silicone
36	790075	Brake Disk	157	788088A	Oil Seal 3 / 4"
37	790007	Brake Pad Plate	180	730229A	Gear Oil 80W90
38	799021	Brake Pad (pkg of 2)	900	794712	Replacement MST 206-545C Transaxle

NOTE: All component dimensions given in
U.S. inches 1 inch = 25.4 mm

**TRACTOR - - MODEL NUMBER 917.273471
 KOHLER ENGINE-MODEL NUMBER CV624, TYPE NUMBER 65596**

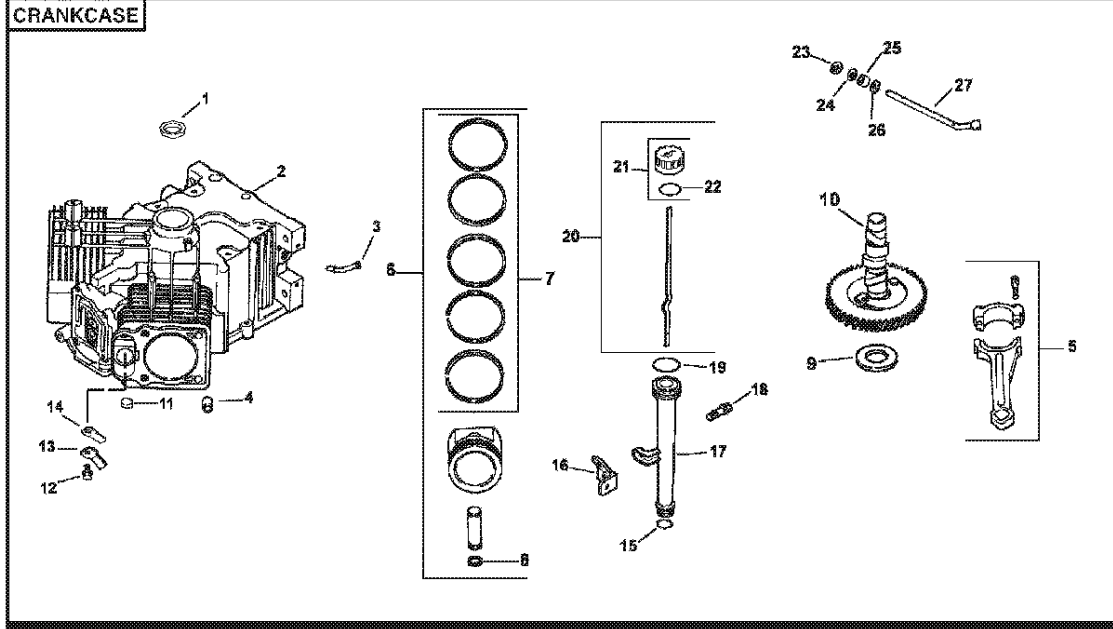
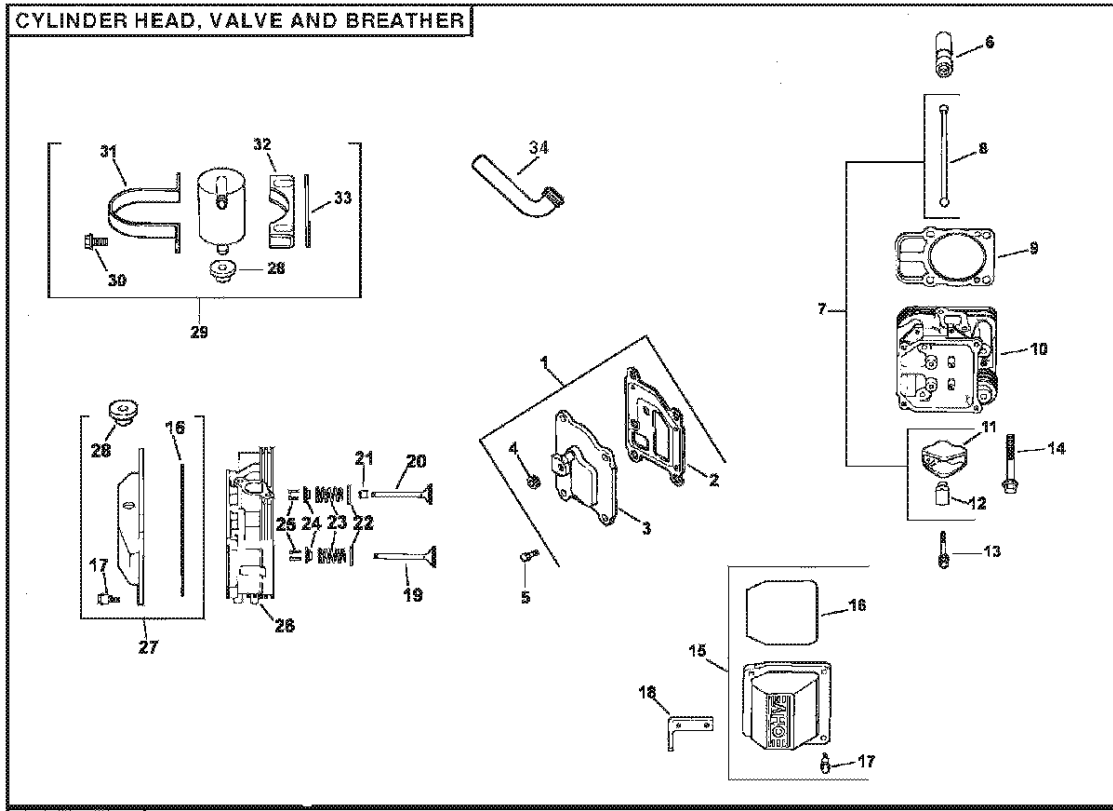

**TRACTOR - - MODEL NUMBER 917.273471
KOHLER ENGINE-MODEL NUMBER CV624, TYPE NUMBER 65596**

HEAD/VALVE/BREATHER

KEY PART NO. NO.	DESCRIPTION
1	24-033-01-S Kit, breather cover w/gasket (Includes 2-4)
2	24-041-23-S Gasket, breather
3	24-096-87-S Cover, breather
4	25-139-60-S Plug, allen hd. 1/8"
5	M-645020 Screw, hex. flange M6x1.0x20 (4)
6	25-351-01-S Lifter, valve (4)
7	24-755-66-S Kit, valve train (Includes 8,11,12)
8	24-411-05-S Rod, push (4)
9	24-041-08-S Gasket, cylinder head (2)
10	24-318-70-S Head assembly, #2 cylinder
11	25-186-01-S Arm, rocker (4)
12	24-599-01-S Pivot, rocker arm (4)
13	M-640034-S Screw, hex. flange M6x1.0x34 (4)
14	12-086-16-S Screw, hex. flange M10x1.5x90 (8)
15	24-755-74-S Kit, valve cover - plain (Includes 16,17)
16	24-153-23-S O-Ring
17	24-086-32-S Screw, shoulder (4)
18	24-445-01-S Strap, lifting
19	24-016-01-S Valve, exhaust (Std.) (2)
	24-016-02-S Valve, exhaust (.25) (2)
20	24-017-01-S Valve, intake (Std.) (2)
	24-017-02-S Valve, intake (.25) (2)
21	66-032-05-S Seal, valve stem (2)
22	235011-S Retainer, spring (4)
23	24-089-02-S Spring, valve (4)
24	12-173-01-S Cap, valve spring (4)
25	12-755-03-S Kit, retainer (4)
26	24-318-67-S Head assembly, #1 cylinder
27	24-755-76-S Kit, valve cover - breather (Incl. 16,17,28)
28	25-313-02-S Grommet, rubber
29	24-755-57-S Kit, breather separator (Includes 28,30-33)
30	M-545016-S Screw, hex. flange M5x0.8x16 (2)
31	24-445-02-S Strap, breather
32	24-126-44-S Bracket, breather separator
33	24-112-12-S Spacer
34	24-326-55-S Hose, Breather

CRANKCASE

KEY PART NO. NO.	DESCRIPTION
1	24-032-01-S Seal, oil front
2	Crankcase (USE: Miniblock 24 782 34)
3	24-294-13-S Fitting
4	24-380-13-S Pin, dowel locating (6)
5	24-067-13-S Connecting Rod (Std.) (2)
	24-067-14-S Connecting Rod (.25) (2)
6	24-874-17-S Piston w/Ring Set (Std.) (2) (Includes 7, 8)
	24-874-18-S Piston w/Ring Set (.25) (2)
	24-874-19-S Piston w/Ring Set (.50) (2)
	24-874-14-S Piston w/ring set (.08)
7	24-108-11-S Ring Set (Std.) (2)
	24-108-12-S Ring Set (.25) (2)
	24-108-13-S Ring Set (.50) (2)
8	24-018-01-S Retainer, piston pin (4)
9	12-422-09-S Shim, camshaft (A.R.)
	12-422-13-S Shim, camshaft (A.R.)
	12-422-07-S Shim, camshaft (A.R.)
	12-422-08-S Shim, camshaft (A.R.)
	12-422-10-S Shim, camshaft
	12-422-11-S Shim, camshaft (A.R.)
	12-422-12-S Shim, camshaft (A.R.)
10	24-012-10-S Camshaft
11	52-139-09-S Plug, cup
12	M-545010-S Screw, hex. flange M5x0.8x10 (2)
13	24-018-04-S Retainer, reed (2)
14	24-402-05-S Reed, breather (2)
15	12-153-01-S O-Ring, lower oil fill tube
16	24-126-19-S Bracket, oil fill tube
17	12-123-04-S Tube, oil fill
18	M-545016-S Screw, hex. flange M5x0.8x16
19	12-153-02-S O-Ring, upper oil fill tube
20	24-038-04-S Dipstick assembly (Includes 21, 22)
21	24-755-46-S Kit, oil fill cap (Includes 22)
22	12-153-03-S O-Ring, dipstick
23	24-018-09-S Retainer, ring
24	M-931010-S Washer, nylon (top)
25	28-032-09-S Seal, governor cross shaft
26	24-468-15-S Washer (bottom)
27	24-144-38-S Shaft, governor cross

NOTE: All component dimensions given in U.S. inches 1 inch = 25.4 mm

TRACTOR - - MODEL NUMBER 917.273471
KOHLER ENGINE-MODEL NUMBER CV624, TYPE NUMBER 65596

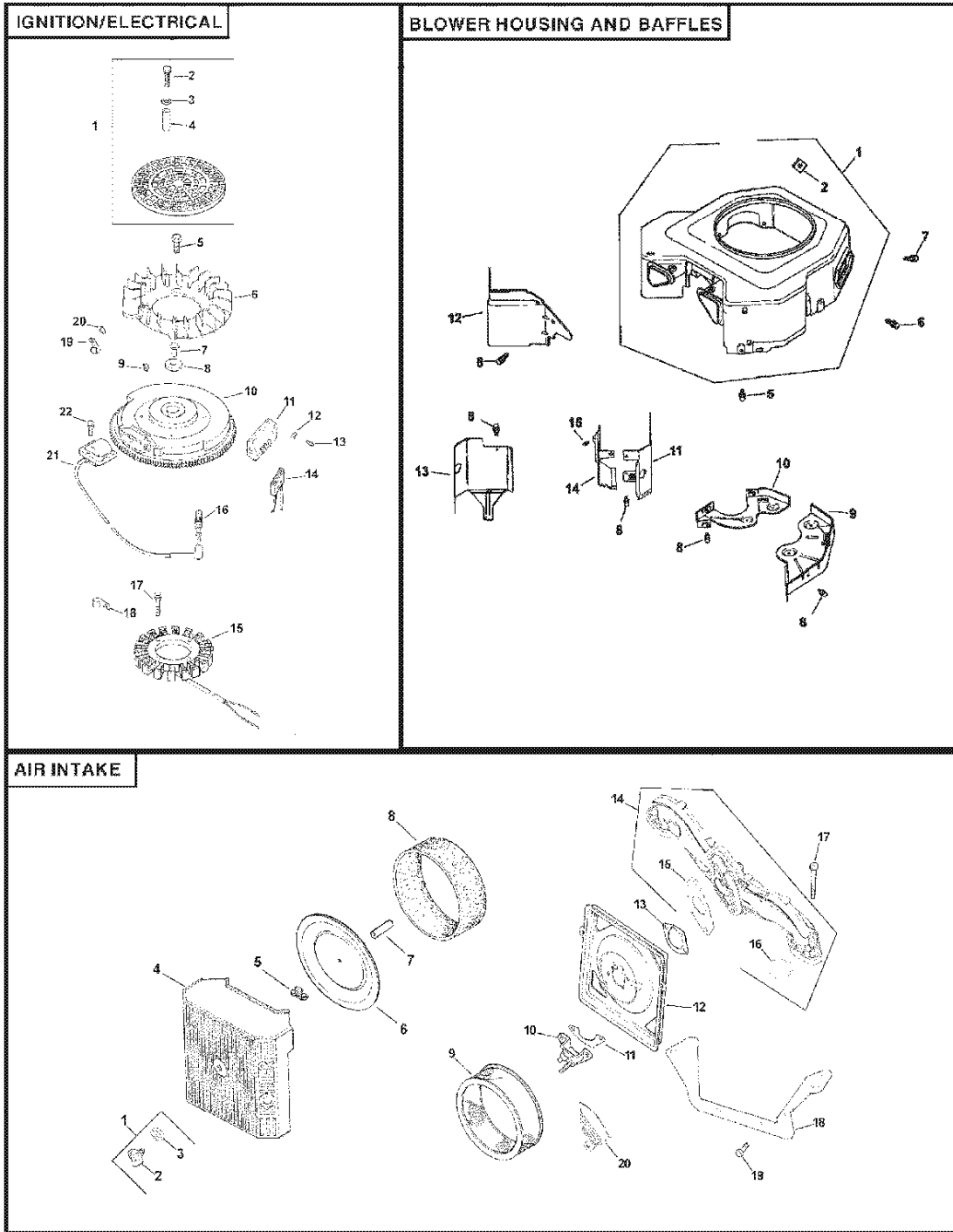

**TRACTOR - - MODEL NUMBER 917.273471
KOHLER ENGINE-MODEL NUMBER CV624, TYPE NUMBER 65596**

IGNITION/CHARGING

KEY PART NO.	NO.	DESCRIPTION
1	54-755-15-S	Kit, grass screen (Includes 2-4, and 24 113 18-S)
2	M-403025-S	Screw, hex. cap M4x0.7x25 (4)
3	X-25-92-S	Washer, plain 5/16" (4)
4	24-112-04-S	Spacer, grass screen (4)
5	25-086-47-S	Bolt, shoulder M6 X1.0 X16 S(4)
6	24-157-08-S	Fan
7	12-086-14-S	Screw, hex. flange M10x1.5x46
8	12-468-03-S	Washer, plain 3/8".
9	X-42-15-S	Key
10	24-025-04-S	Flywheel
11	25-403-03-S	Rectifier-regulator
12	X-25-92-S	Washer, plain 3/16" (2)
13	24-086-18-S	Screw, phillips hd. 11-16x7/8 (2)
14	236602-S	Connector (3 contact)
15	54-755-09-S	Kit, 15 amp stator (Includes 24 126 71-S)
16	12-132-02-S	Spark Plug (2)
17	M-548025-S	Screw, hex. cap M5x0.8x25 (2)
18	235173-S	Clip, cable
19	48-154-02-S	Clip, cable
20	X-25-63-S	Washer, plain 1/4"
21	24-584-01-S	Module, ignition (2)
22	M-545020-S	Screw, hex. flange M5x0.8x20 (4)
NOT ILLUSTRATED		
--	24-126-71-S	Bracket, stator wire
--	X-22-11-S	Washer, lock 1/4"
--	24-176-82-S	Harness, wiring Lead, black (rect.-reg. 5" - 12 gauge)
--	24-518-12-S	insulated grip barrel eyelets)
--	24-113-18-S	Decal, grass screen
--	25-454-03-S	Tie, wire (3)

BLOWER HOUSING & BAFFLES

KEY PART NO.	NO.	DESCRIPTION
1	24-027-114-S	Housing, blower (Incl. 2,24-096-85-s, 25-086-91-s)
2	24-100-01-S	Nut plastic (2)
5	M-545020-S	Screw, hex. flange M5x0.8x20 (4)
6	M-545016-S	Screw, hex. flange M5x0.8x16 (3)
7	M-551016-S	Screw, hex. flange M5x0.8x16
8	M-645016-S	Screw, hex. flange M6x1.0x16 (6)
9	24-146-16-S	Plate, backing - # 2 side
10	24-146-20-S	Plate, backing - # 1 side
11	24-063-20-S	Baffle, cylinder barrel-# 2 side
12	24-063-14-S	Baffle, valley - #2 side
13	24-063-58-S	Baffle, cylinder barrel-# 1 side
14	24-063-60-S	Baffle, valley - #1 side
15	M-545010-S	Screw, hex. flange M5x0.8x10 (2)

NOT ILLUSTRATED

24-096-85-S	Cover, blower housing
25-086-91-S	Screwing 10-16X1/2

AIR INTAKE/FILTRATION

KEY PART NO.	NO.	DESCRIPTION
1	54-755-01-S	Kit, knob with seal (Includes 2,3)
2	25-341-03-S	Knob, cover
3	24-153-20-S	O-Ring
4	24-096-67-S	Cover, air cleaner
5	12-100-01-S	Wing Nut
6	24-096-01-S	Cover, inner air cleaner
7	24-032-03-S	Seal, inner air cleaner
8	24-083-02-S	Precleaner, element
9	47-083-03-S	Element, air cleaner
10	24-109-10-S	Cup, fuel spitback
11	24-041-13-S	Gasket, fuel spitback cup
12	24-094-33-S	Base, air cleaner
13	24-041-14-S	Gasket, air cleaner base
14	24-164-51-S	Manifold, intake (Includes 15, 16)
15	24-041-52-S	Gasket, carburetor
16	24-153-27-S	O-ring(2)S
17	M-651055-S	Screw, hex. flange M6x1.0x55 (4)
18	24-126-130-S	Bracket, air cleaner base
19	M-545010-S	Screw, hex flange M5X0.8X10(2)
20	24-063-51-S	Baffle, fuel spit-back

NOTE: All component dimensions given in U.S. inches 1 inch = 25.4 mm

**TRACTOR - - MODEL NUMBER 917.273471
KOHLER ENGINE-MODEL NUMBER CV624, TYPE NUMBER 65596**

STARTING SYSTEM

KEY PART NO. NO.	DESCRIPTION
1	M-839080-S Screw, hex. flange M8x1.25x80 (2)
2	25-098-09-S Starter, solenoid shift assembly (Includes 3-7)
3	25-086-113-S Screw, external torx head (3)
4	25-435-05-S Kit, solenoid (Includes 3)
5	25-755-33-S Kit, pinion drive (Includes 6)
6	25 141 05-S Ring
7	25-221-01-S Kit, brush

ENGINE CONTROLS

KEY PART NO. NO.	DESCRIPTION
1	24-211-03-S Bolt, round head square neck
2	24-090-33-S Lever, governor
3	M-641060-S Nut, hex. flange M6x1.0
4	24-089-01-S Spring, linkage
5	25-158-08-S Bushing, linkage retaining
6	24-079-04-S Linkage, throttle
7	25-158-11-S Bushing, throttle linkage
8	M-545016-S Screw, hex. flange M5x0.8x16 (1)
9	M-547050-S Nut, hex. lock M5x0.8
10	24-089-03-S Spring, choke return
11	24-126-56-S Bracket, control
12	M-645016-S Screw, hex. flange M6x1.0x16 (4)
13	12-237-01-S Clamp, cable (2)
14	24-086-43-S Screw, thread forming (2)
15	24-090-07-S Lever, throttle actuator
16	X-20-1-S Washer, lock 1/4"
17	M-541050-S Nut, hex. flange M5x0.8
18	24-468-01-S Washer, plain 5.5 mm (3)
19	24-089-45-S Spring, governor
20	M-446030-S Nut, hex. M4x0.7
21	24-090-13-S Lever, throttle control
22	M-545020-S Screw, hex. flange M5x0.8x20
23	24-089-51-S Spring, throttle limiter
24	24-090-05-S Lever, choke
25	41-468-03-S Washer, spring 1/4"
26	M-403025-S Screw, hex. cap M4x0.7x25
27	24-079-22-S Linkage, choke

OIL PAN/LUBRICATION

KEY PART NO. NO.	DESCRIPTION
1	24-199-07-S Pan, oil assembly (Includes 2-11)
2	M-645025-S Screw, hex. flange M6x1.0x25 (2)
3	M-631005-S Washer, plain 6 mm (2)
4	24-393-37-S Oil pump assembly (Includes 5,6)
5	24-381-11-S Tube, oil pickup
6	24-153-01-S O-Ring, Oil pump
7	24-043-12-S Screen, oil
8	24-043-12-S Kit, governor gear w/pin (Includes 9)
9	12-380-01-S Pin, governor regulating
10	52-448-02-S Tab, locking
11	12-144-02-S Shaft, governor gear
12	24-153-08-S O-Ring
13	24-136-01-S Nipple, oil filter
14	52-050-02-S Filter, oil
15	25-139-62-S Plug, hex. ctsk. 3/8"
16	52-032-08-S Seal, oil (PTO end)
17	24-086-17-S Screw, hex. flange M8x1.25x45
18	24-086-16-S Screw, hex. flange M8x1.25x45 (9)
19	25-139-57-S Plug, sq. hd. solid 3/8" N.P.T.F.

NOTE: All component dimensions given in U.S. inches 1 inch = 25.4 mm

**TRACTOR - - MODEL NUMBER 917.273471
KOHLER ENGINE-MODEL NUMBER CV624, TYPE NUMBER 65596**

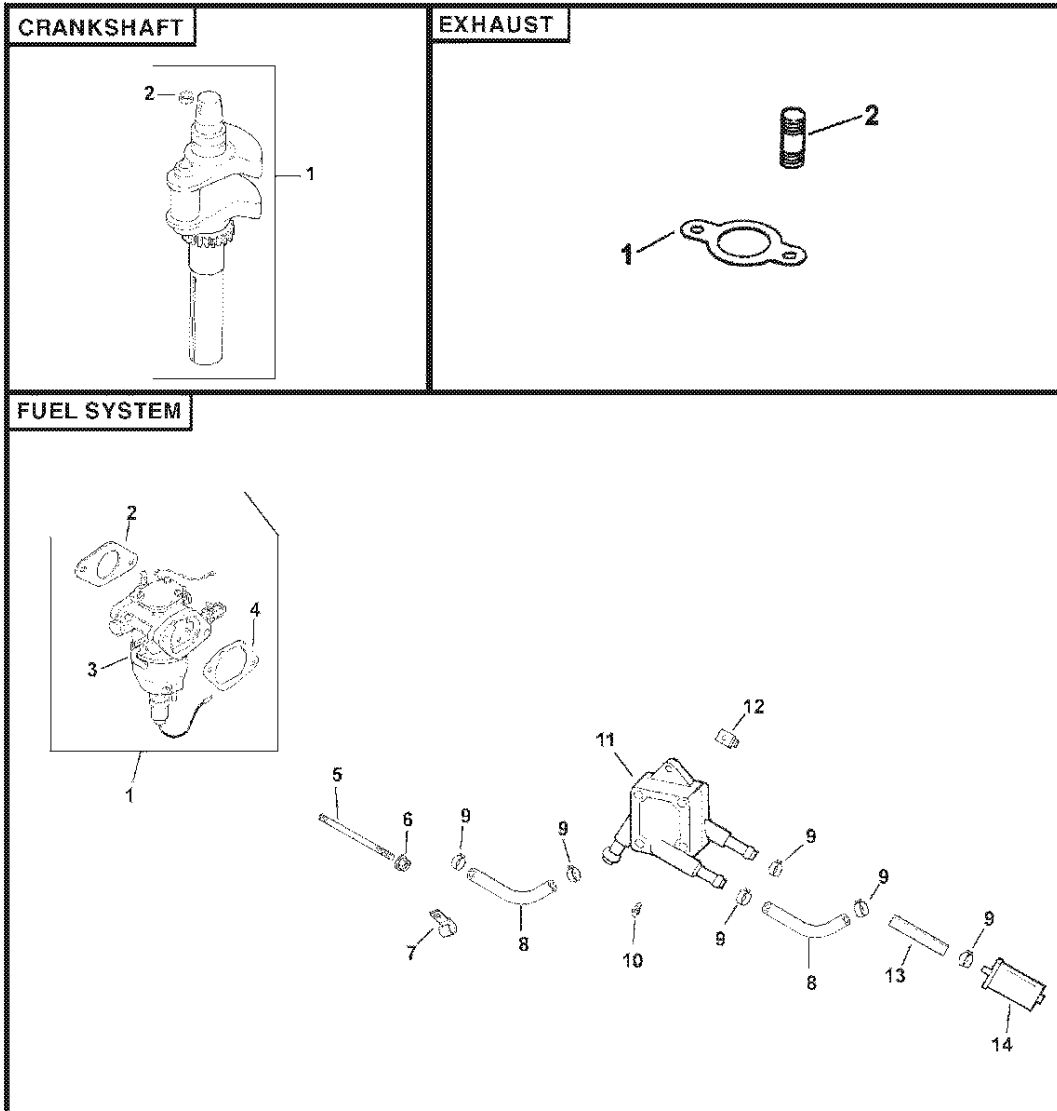

**TRACTOR - - MODEL NUMBER 917.273471
 KOHLER ENGINE-MODEL NUMBER CV624, TYPE NUMBER 65596**

CRANKSHAFT

KEY NO.	PART NO.	DESCRIPTION
1	24-014-42-S	Crankshaft (Includes 2)
2	52-139-09-S	Plug, cup

EXHAUST

KEY NO.	PART NO.	DESCRIPTION
1	24-041-49-S	Gasket, exhaust (2)
2	25-072-04-S	Stud, M8x1.25x33 (4)
NOT ILLUSTRATED		
--	PA-65596	Replacement Engine PA-65596
--	24-522-221	Short Block
--	24-782-34	Miniblock
--	24-755-107-S	Gasket Set

FUEL SYSTEM

KEY NO.	PART NO.	DESCRIPTION
1	24-853-25-S	Kit, carburetor w/gaskets (Includes 2-4)
2	24-041-52-S	Gasket, carburetor
3	24-053-25	Carburetor assembly (For information only not available separately) (Service with kits 24-757-18-S, 24-757-19-S, 24-757-20-S, 24-757-22-S)
4	24-041-14-S	Gasket, air cleaner base
5	M-629095-S	Stud, M6x1.0x95 (2)
6	M-641060-S	Nut, hex. flange M6x1.0 (2)
7	47-154-01-S	Clip, cable
8	24-353-03-S	Line, fuel 10-5/8" (2)
9	25-237-14-S	Clamp, hose (6)
10	24-086-12-S	Screw, hex. cap. M6x1.7x18 (2)
11	24-393-16-S	Pump, fuel - pulse
12	24-100-01-S	Nut, plastic (2)
13	15-353-04-S	Line, fuel 11-1/2"
14	24-050-02-S	Filter, fuel
NOT ILLUSTRATED		
--	24-757-18-S	Kit, overhaul w/gaskets
--	24-757-19-S	Kit, choke repair w/gaskets
--	24-757-20-S	Kit, gasket
--	24-757-22-S	Kit, solenoid replacement w/gaskets

NOTE: All component dimensions given in U.S. inches 1 inch = 25.4 mm



SERVICE NOTES

SUGGESTED GUIDE FOR SIGHTING SLOPES FOR SAFE OPERATION

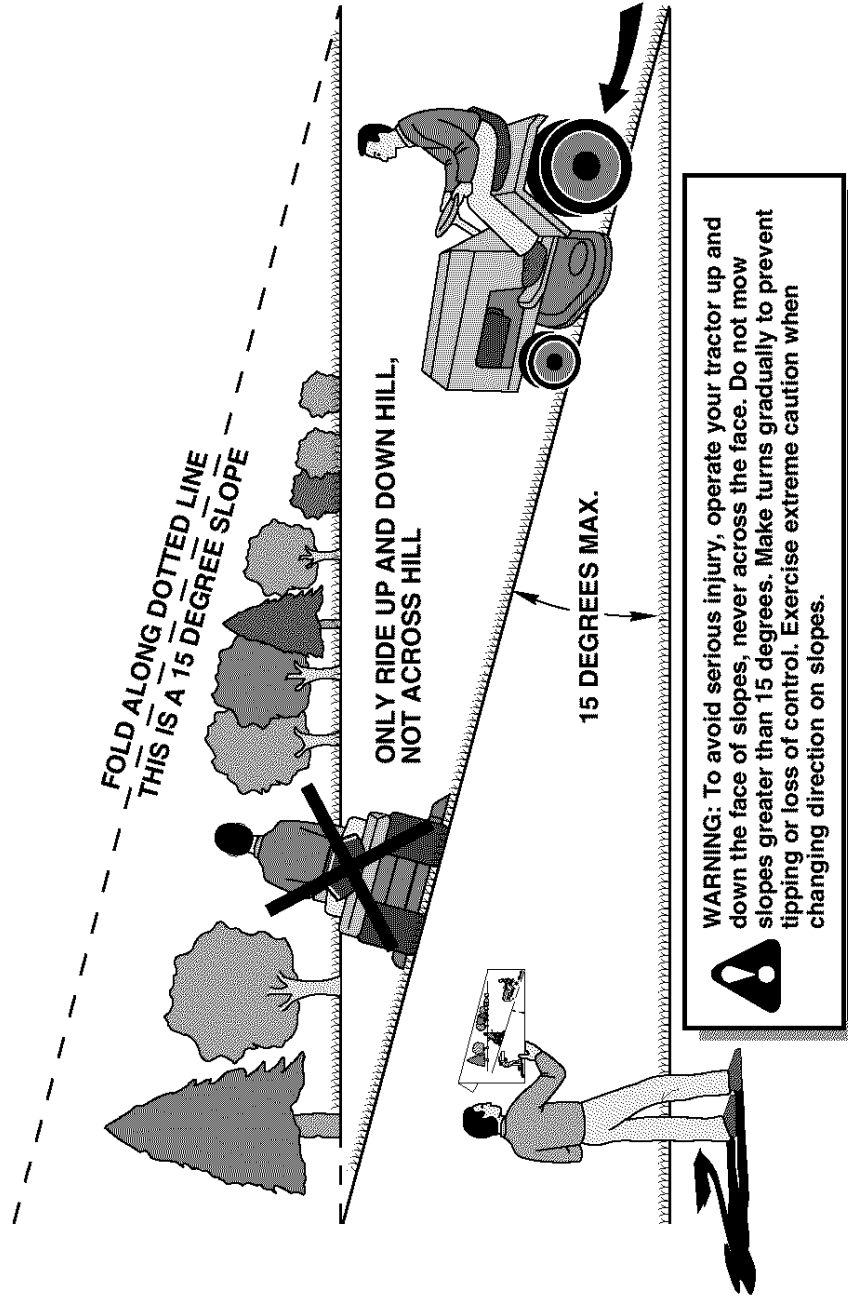

1. Fold this page along dotted line indicated above.
2. Hold page before you so that its left edge is vertically parallel to a tree trunk or other upright structure.
3. Sight across the fold in the direction of hill slope you want to measure.
4. Compare the angle of the fold with the slope of the hill.

Get it fixed, at your home or ours!

Your Home

For repair – **in your home** – of **all** major brand appliances, lawn and garden equipment, or heating and cooling systems, **no matter who made it, no matter who sold it!**

For the replacement parts, accessories and owner's manuals that you need to do-it-yourself.

For Sears professional installation of home appliances and items like garage door openers and water heaters.

1-800-4-MY-HOME[®] Anytime, day or night
(1-800-469-4663) (U S A and Canada)
www.sears.com www.sears.ca

Our Home

For repair of carry-in products like vacuums, lawn equipment, and electronics, call or go on-line for the nearest **Sears Parts and Repair Center.**

1-800-488-1222 Anytime, day or night (U S A only)
www.sears.com

To purchase a protection agreement (U.S.A.) or maintenance agreement (Canada) on a product serviced by Sears:

1-800-827-6655 (U S A) **1-800-361-6665** (Canada)

Para pedir servicio de reparación a domicilio, y para ordenar piezas:

1-888-SU-HOGARSM
(1-888-784-6427)

Au Canada pour service en français:

1-800-LE-FOYER^{MC}
(1-800-533-6937)
www.sears.ca

SEARS

02410

© Sears, Roebuck and Co

® Registered Trademark / TM Trademark / SM Service Mark of Sears, Roebuck and Co

® Marca Registrada / TM Marca de Fábrica / SM Marca de Servicio de Sears, Roebuck and Co

^{MC} Marque de commerce / ^{MD} Marque déposée de Sears, Roebuck and Co