

# SEARS

## owner's manual

Model No.  
536.270212

**CAUTION:**  
Read And Follow  
All Safety Rules  
And Instructions  
Before Operating  
This Equipment.



# CRAFTSMAN

**13.5 HP. ELECTRIC START  
30" MOWER / MULCHER  
5 SPEED  
REAR ENGINE RIDER**

- Assembly
- Operation
- Customer Responsibilities
- Service And Adjustment

# TABLE OF CONTENTS

WARRANTY .....	2	CUSTOMER RESPONSIBILITIES .....	18
CUSTOMER RESPONSIBILITIES .....	3	MAINTENANCE CHART .....	18
PRODUCT SPECIFICATIONS .....	3	CHECK THE TIRES .....	18
SAFETY RULES .....	4	HOW TO REMOVE AND INSTALL THE BLADE .....	19
RESPONSIBILITY OF THE OWNER .....	5	HOW TO SHARPEN THE BLADE .....	19
ACCESSORIES AND ATTACHMENTS .....	6	HOW TO ADJUST THE ATTACHMENT CLUTCH .....	20
ASSEMBLY .....	7	HOW TO CHECK AND ADJUST THE DRIVE BRAKE .....	21
MAINTENANCE FREE BATTERY .....	8	HOW TO CHECK AND ADJUST THE CLUTCH .....	21
HOW TO ASSEMBLE THE STEERING WHEEL .....	9	HOW TO REMOVE THE SIDE PANEL .....	22
HOW TO ASSEMBLE THE HUB CAPS .....	9	BATTERY SERVICE .....	22
CHECK THE TIRES .....	9	HOW TO CHARGE THE BATTERY .....	22
CHECK THE DRIVE BRAKE .....	9	WHERE TO LUBRICATE .....	23
CHECK THE BELTS .....	9	HOW TO CHECK THE OIL .....	24
HOW TO INSTALL THE SEAT .....	10	HOW TO CHANGE THE OIL .....	24
CHECK THE LEVEL OF THE MOWER HOUSING .....	10	HOW TO CLEAN THE COOLING SYSTEM .....	24
OPERATION .....	11	HOW TO CHECK THE MUFFLER .....	24
LOCATION OF CONTROLS .....	11	HOW TO CLEAN THE AIR FILTERS .....	25
HOW TO USE THE THROTTLE CONTROL .....	12	HOW TO CHECK THE SPARK PLUG .....	25
HOW TO USE THE ATTACHMENT CLUTCH .....	12	SERVICE AND ADJUSTMENT .....	26
HOW TO USE THE SHIFT LEVER .....	12	HOW TO ADJUST THE THROTTLE CONTROL .....	26
HOW TO SET THE PARKING BRAKE .....	13	HOW TO REMOVE THE MOWER HOUSING .....	27
HOW TO CHANGE THE CUTTING HEIGHT .....	13	HOW TO INSTALL THE MOWER HOUSING .....	27
HOW TO STOP THE UNIT .....	13	HOW TO LEVEL THE MOWER HOUSING .....	28
HOW TO TRANSPORT THE UNIT .....	13	HOW TO REPLACE THE MOTION DRIVE BELT .....	29
HOW TO OPERATE WITH THE MOWER HOUSING .....	14	HOW TO REPLACE THE MOWER DRIVE BELT .....	30
HOW TO OPERATE THE UNIT ON HILLS .....	14	HOW TO REPLACE THE FUSE .....	31
BEFORE STARTING THE ENGINE .....	15	HOW TO SET THE CUTTING HEIGHT .....	31
HOW TO START THE ENGINE .....	15	HOW TO CLEAN THE MOWER HOUSING .....	31
HOW TO START WITH A WEAK BATTERY .....	15	FRONT WHEEL ALIGNMENT .....	31
HOW TO CHANGE THE MULCHER PLATE .....	16	STORAGE (OVER 30 DAYS) .....	32
OPERATING TIPS .....	17	TROUBLE SHOOTING CHART .....	33
MOWING AND BAGGING TIPS .....	17	SLOPE GUIDE .....	34
MULCHING TIPS .....	17	INDEX .....	35
		REPAIR PARTS .....	36

## LIMITED WARRANTY ON CRAFTSMAN EQUIPMENT PARTS

For two (2) years from the date of purchase, if this Craftsman Equipment is maintained, lubricated and tuned up according to the instructions in the owner's manual, Sears will repair or replace free of charge any parts found to be defective in material or workmanship. Warranty service is available free of charge by taking your Craftsman equipment to your nearest Sears Service Center. In-home warranty service is available but a trip charge will apply. This Warranty applies only while this product is in the United States.

This Warranty does not cover:

- .. Expendable items which become worn during normal use, such as blades, spark plugs, air cleaners, belts, and oil filters.
- .. Tire replacement or repair caused by punctures from outside objects, such as nails, thorns, stumps or glass.
- .. Repairs necessary because of operator abuse, including but not limited to, damage caused by towing objects beyond the capability of the equipment, impacting objects that bend the frame or crankshaft, or over-speeding the engine.
- .. Repairs necessary because of operator negligence, including but not limited to, electrical and mechanical damage caused by improper storage, failure to use the proper grade and amount of engine oil, failure to keep the deck clear of flammable debris, or failure to maintain the equipment according to the instructions contained in the owner's manual.
- .. Engine (fuel system) cleaning or repairs caused by fuel determined to be contaminated or oxidized (stale). In general, fuel should be used within 30 days of its purchase date.
- .. Equipment used for commercial or rental purposes.

## LIMITED WARRANTY ON BATTERY

For ninety (90) days from date of purchase, if any battery is included with the equipment proves defective in material or workmanship and our testing determines the battery will not hold a charge, Sears will replace the battery at no charge. Warranty service is available free of charge by taking your Craftsman equipment to your nearest Sears Service Center. In-home warranty service is available but a trip charge will apply. This Warranty applies only while this product is in the United States.

**TO LOCATE THE NEAREST SEARS SERVICE CENTER OR TO SCHEDULE SERVICE, SIMPLY CONTACT SEARS AT 1-800-488-1222.**

This warranty gives you specific legal rights, and you may also have other rights, which vary from state to state.

Congratulations on your purchase of a Sears Rider. It has been designed, engineered and manufactured to give you the best possible dependability and performance.

If you experience any problems you cannot easily remedy, please see your nearest Sears Service Department. We have competent, well trained technicians and the proper tools to service or repair this unit.



Please read and keep this manual. The instructions will enable you to assemble and maintain your unit properly. Always observe the "Safety Rules".

## CUSTOMER RESPONSIBILITIES

- .. Carefully read and follow the rules for safe operation. Inspect the unit.
- .. Follow all the assembly instructions. Carefully adjust the unit.
- .. Know how to operate all standard and accessory equipment on the unit. Make sure the operator can correctly operate the unit.
- .. Operate the unit only with guards, shields and other safety items in place and working correctly.
- .. Complete all maintenance on the unit. Service the unit only with authorized or approved replacement parts.
- .. See the Maintenance Chart.

**NOTE:** This unit is equipped with an internal combustion engine and must not be used on or near any unimproved forest-covered, brush-covered or grass-covered land unless the engine's exhaust system is equipped with a spark arrester meeting applicable local or state laws (if any). If a spark arrester is used, it must be maintained in effective working order by the operator.

In the State of California, the above is required by law (Section 4442 of the California Public Resources Code). Other states may have similar laws. Federal laws apply on federal lands. See an Authorized Service Center for a spark arrester for the muffler.

**WARNING:**

**The engine exhaust from this product contains chemicals known to the State of California to cause cancer, birth defects or other reproductive harm.**

## MAINTENANCE AGREEMENT

A Sears Maintenance Agreement is available on this unit. See the nearest Sears Store for information.

---

## PRODUCT SPECIFICATIONS

- Engine ..... 13.6 HP.
- Charging System ..... 3 amperes at 3600 rpm
- Fuel Tank Size ..... 1 gallon
- Type of Fuel ..... Unleaded Regular
- Oil Capacity ..... 32 ounces (1 quart)
- Oil Type ..... Above 32 degrees SAE 30  
..... Below 32 degrees SAE 5W30
- Spark Plug (Gap 0.030") .. Champion RJ4C
- Tire Air Pressure ..... Front 22 psi (See tire sidewall)
- Tire Air Pressure ..... Rear 14 psi (See tire sidewall)
- All Gear Transaxle ..... 5 forward speeds and 1 reverse
- Ground Speed Range ..... Forward 4.3 mph  
..... Reverse 2.1 mph
- Tilt Seat ..... Tilts forward to access the battery.
- Mower Housing ..... Full-floating suspension, one blade.
- Cutting Height ..... 8 positions from 1½ to 4 inches.
- Blade Nut Torque ..... 30 foot-pounds (ft-lbs)

F-000614J

**Rear Engine Rider**

Record in the space below the serial number and the date of purchase of this unit.

The model number and serial number are found on a decal attached to the rear of the frame.

**Model Number:** 536.270212

**Serial Number:** \_\_\_\_\_

**Date of Purchase:** \_\_\_\_\_

Keep these numbers for future reference.



---

# OWNER'S INFORMATION

---

## SAFETY RULES

### Safe Operation Practices for Ride-on Mowers



**WARNING:** This cutting machine is capable of amputating hands and feet and throwing objects. Failure to observe the following safety instructions could result in serious injury or death.

#### I. General operation

1. Read, understand and follow all instructions in the Instruction Book, on the machine, the engine and with any attachments before starting.
2. Only allow responsible adults, who are familiar with the instructions, to operate the machine.
3. Clear the area of objects such as rocks, toys, wire, etc., which could be picked up and thrown by the blade.
4. Be sure the area is clear of other people before mowing. Stop the machine if anyone enters the area.
5. Never carry passengers.
6. Turn off power to the blades or any attachments before backing up. Do not mow in reverse unless absolutely necessary. Always look down and behind before and while backing.
7. Be aware of the mower discharge direction and do not point it at anyone. Do not operate the mower without either the entire grass bagger or the mower guard in place.
8. Slow down before turning.
9. Never leave a machine unattended with the engine running. Always turn off the blade(s), set the parking brake, stop the engine and remove the key before dismounting.
10. Turn off power to attachment(s) when transporting or not in use. Turn off the blade(s) when not mowing.
11. Stop the engine before removing the grass bagger or unclogging the chute.
12. Mow only in daylight or good artificial light.
13. Do not operate the machine while under the influence of alcohol or drugs or when very tired.
14. Watch for traffic when operating near or crossing roadways.
15. Use extra caution when loading or unloading the machine into a trailer or truck.
16. Disengage all attachment clutches and shift into Neutral before attempting to start the engine.
17. Always wear goggles, safety glasses, or an eye shield when you operate the unit to protect your eyes from foreign objects that can be thrown from the unit. Always wear eye protection when you make an adjustment or repair to the machine.
18. Use care when pulling loads or using heavy equipment.
  - a. Use only approved drawbar hitch points.
  - b. Limit loads to those you can safely control.
  - c. Do not turn sharply. Use care when backing.
  - d. Use counterweights or wheel weights when suggested in the Instruction Book.
19. Do not operate this machine if you are taking drugs or other medication which can cause drowsiness or affect your ability to operate this machine.
20. Do not use this machine if you are mentally or physically unable to operate this machine safely.
21. Data indicates that operators, age 60 years and above, are involved in a large percentage of riding mower related injuries. These operators should evaluate their ability to operate a riding mower safely enough to protect themselves and others from serious injury.

#### II. Slope operation

**Slopes and rough terrain are major factors related to loss-of-control and tip-over accidents, which can result in severe injury or death. ALL slopes require extra caution. If you cannot back up the slope or if you feel uneasy on the slope, do not mow it. See the "Slope Guide" in the back of this book to check for safe operation.**

##### DO

1. Mow up and down slopes, not across.
2. Remove obstacles such as rocks, limbs, etc...
3. Watch for holes, ruts or bumps. Uneven terrain could overturn the machine. *Tall grass can hide obstacles.*
4. Follow the manufacturer's recommendations for wheel weights or counterweights to improve stability.
5. Use extra care with grass baggers or other attachments, they can change the stability of the machine.
6. Keep all movement on the slopes **slow and gradual**. Do not make sudden changes in speed or direction.
7. Avoid starting or stopping on a slope. If tires lose traction, turn off the blades and proceed slowly **straight down** the slope.

##### DO NOT

1. **Do not** turn on slopes unless absolutely necessary, then only turn slowly and gradually downhill, if possible.
2. **Do not** mow drop-offs, ditches or embankments. A wheel over the edge or an edge caving in could cause a sudden overturn and an injury or death.
3. **Do not** mow on wet grass. Reduced traction could cause sliding.
4. **Do not** try to stabilize the machine by putting your foot on the ground.
5. **Do not** use a grass bagger or other rear mounted accessories on steep slopes (greater than 10 degrees).

---

## OWNER'S INFORMATION

---

### III. Children

**Tragic accidents can occur if the operator is not alert to the presence of children. Children are often attracted to the machine and the mowing activity. NEVER assume that children will remain where you last saw them.**

1. Keep children out of the mowing area and in the watchful care of another responsible adult.
2. Be alert and turn the engine off if children enter the area.
3. Before and when backing, look **behind and down** for small children.
4. Never carry children or any passengers, even with the blades off. They may fall off and be seriously injured or interfere with the safe operation of the machine.
5. Never allow children to operate the machine. Instruct children in the potential dangers of the machine.
6. Use extra care when approaching blind corners, shrubs, trees or other objects that may obscure vision.

### IV. Service

1. Use extra care when handling gasoline and other fuels. Fuels are flammable and the vapors are explosive.
  - a. Use only an approved container.
  - b. Never remove the gas cap or add fuel with the engine running. Allow the engine to cool for several minutes before refueling. Do not smoke.
  - c. Never refuel the machine indoors.
  - d. Never store the machine with fuel in the tank or fuel container inside where there is an open flame, such as a water heater.
2. Never start or run the engine inside a closed area.
3. Keep all nuts and bolts, especially the blade attachment nuts tight. Frequently check the blade(s) for wear or damage such as cracks and nicks. A blade that is bent or damaged must be immediately replaced with an original equipment blade from an authorized service dealer. For safety, replace the blade every two years. Keep the equipment in good condition.
4. Never tamper with the safety devices. Check their proper operation regularly.
5. To reduce fire hazards, keep the machine free of grass, leaves or other debris build-up. Clean up oil or fuel spills. Allow the machine to cool before storing.
6. Stop and inspect the equipment if you strike an object. Repair, if necessary, before restarting.
7. Never make adjustments or repairs with the engine running. The carburetor can be adjusted with the engine running. Do not change the engine governor settings or over-speed the engine.
8. Grass bagger components are subject to wear, damage and deterioration, which could expose moving parts or allow objects to be thrown. For storage, always make sure the grass bag is empty. Frequently check components and replace with manufacturer's recommended parts when necessary.
9. Mower blade(s) are sharp and can cut. Wrap the blade(s) or wear gloves and use extra caution when servicing them or the blade housing area.
10. Check the brake operation frequently. Adjust and service as required.
11. Wait for all movement to stop before servicing any part of the unit.

## RESPONSIBILITY OF THE OWNER

### Environmental Awareness

- .. Do not fill the engine's fuel tank completely full.
- .. Drain fuel for off-season storage.
- .. Use only unleaded gasoline.
- .. Service the air cleaner regularly.
- .. Change oil regularly. Use 30W oil in summer.
- .. Tune-up the engine regularly.
- .. Keep equipment in efficient operating condition.
- .. Dispose of used engine oil properly.



**Look for this symbol to indicate important safety precautions. This symbol indicates: "Attention! Become Alert! Your Safety is At Risk."**

# ACCESSORIES AND ATTACHMENTS

## ACCESSORIES AND ATTACHMENTS

These accessories and attachments were available when the unit was purchased. They are also available at most Sears retail outlets, catalog and service centers. Most Sears stores can order these items for you when you provide the model number of your riding mower.

### ENGINE

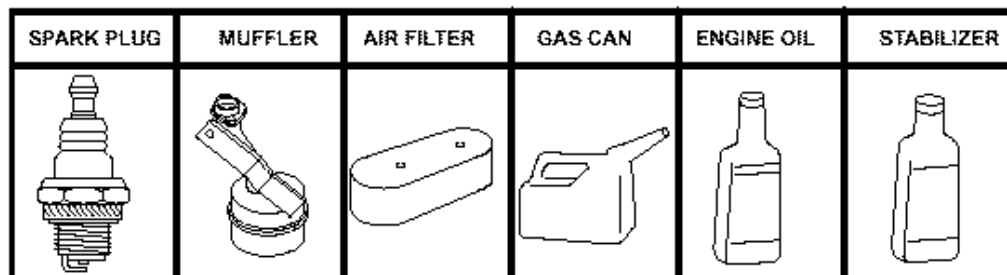

### MAINTENANCE

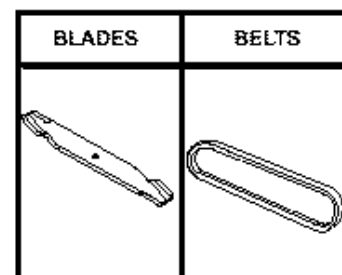

## PERFORMANCE

Sears offers a wide variety of attachments that fit your riding mower. Many of these are listed below with brief explanations of how they can help you. This list was current at the time of publication; however, it may change in future years – more attachments may be added, changes may be made in these attachments, or some may no longer be available or fit your model. **Contact your nearest Sears store for the accessories and attachments that are available for your unit.**

Most of these attachments do not require additional hitches or conversion kits (those that do are indicated) and are designed for easy attaching and detaching.

**GRASS BAGGER** lets you collect grass clippings and leaves for a healthier, neater looking lawn. Two Grass containers hold 33 gallon disposable plastic bags and offers 7 bushel capacity.

**LAWN SWEEPERS** let you collect grass clippings and leaves.

**LAWN VACS** for powerful collection of heavy grass clippings and leaves. Wand attachment to pick up debris in hard-to-reach places.

**CARTS** make hauling easy. Variety of sizes available.

**ROLLER** for smoother lawn surface. 36-inch wide, 18-inch diameter water-tight drum holds up to 390-lbs. of weight. Rounded edges prevent harm to turf. Adjustable scraper automatically cleans drum.

**SPREADER/SEEDERS** make seeding, fertilizing and weed killing easy. Broadcast spreaders are also useful for granular deicers and sand.

**CORING AERATOR** takes small plugs out of soil to allow moisture and nutrients to reach grass roots. 36-inch swath. 24 hardened 2.5-inch steel coring tips. 150-lb. weight tray.

**AERATOR** promotes deep root growth for a healthy lawn. Tapered 2.5-inch steel spikes mounted on 10-inch diameter disc puncture holes in soil at close intervals to let moisture soak in. Steel weight tray for increased penetration.

**MULCH RAKE/DETHATCHER** loosens soil and flips thatch and matted leaves to lawn surface for easy pickup. Twenty spring tine teeth. Useful to prepare bare areas for seeding. Available for front or rear mounting.

**SPRAYERS** use 12-volt DC electric motor that connects to the riding mower battery or other 12-volt source. Includes booms for automatic spraying when pulling, and hand held wand for spot spraying. Wand has adjustable spray pattern. For applying herbicides, insecticides, fungicides and liquid fertilizers.

**NOTE: Do not use pull-behind attachments on slopes that are greater than 10 degrees.**

# ASSEMBLY

## PREPARATION

The unit is completely assembled except for the items shown in Figure 1. These items are in the carton along with a parts bag. The parts bag contains the fasteners needed to complete the assembly of the unit. Find and remove these items. Do not discard any parts or material until the unit is assembled.

## HOW TO REMOVE FROM THE CARTON

To remove the unit from the carton, follow the instructions below.

1. Open the top of the carton.
2. Remove the wood frame at the top of the carton.
3. Cut each corner of the carton from the top to the bottom with a knife. Lower the sides of the carton to the ground.
4. Move the shift lever to the neutral (N) position.

**NOTE:** See the Operation section, page 11, for the location of the controls.

5. If the parking brake is engaged, completely depress the clutch/brake pedal to release the brake.
6. Move the lift lever to the highest position.

**CAUTION:** Check the bottom of the carton for staples. Remove any staples that are in the path of the tires.

7. From the front of the riding mower, carefully pull the riding mower forward off the wood frame.

## TOOLS YOU NEED TO ASSEMBLE THE UNIT

- |                                   |                          |
|-----------------------------------|--------------------------|
| 1. Adjustable wrench (2 required) | 5. Phillips screwdriver  |
| 2. Open end wrench 1/2" - 9/16"   | 6. Tire pressure gauge   |
| 3. Open end wrench 7/16" - 1/2"   | 7. Knife                 |
| 4. Blade type screwdriver         | 8. Socket Set (Optional) |

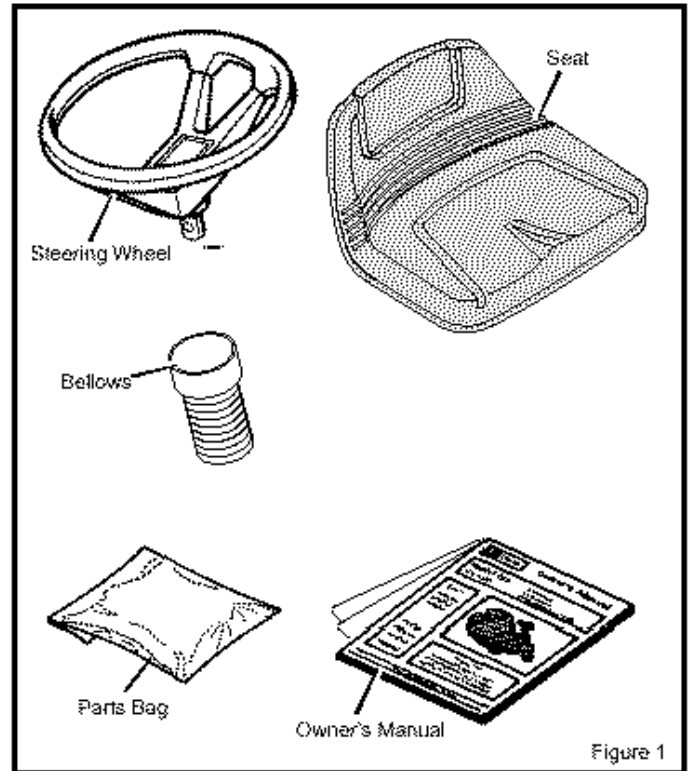
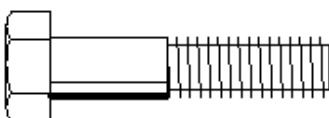

Figure 1

## MOWER PARTS BAG – CONTENTS

The fasteners and other loose parts are shown below. The fasteners are shown at full size. The quantity is shown in brackets ( ). On some models, all of the fasteners are not required.



1x102  
(1) Hex Bolt  
5/16" - 18x1 1/2"  
STD523115



18x16  
(2) Lockwasher  
STD551131

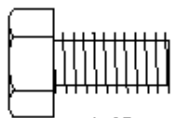

1x45  
(2) Hex Bolt  
5/16" - 18x5/8"  
STD523106

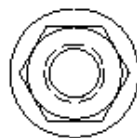

15x88  
(1) Flange Nut  
5/16" - 18  
STD541431



91275  
(2) Ignition Key

F-000614J

7

# ASSEMBLY

## MAINTENANCE FREE BATTERY

1. Check the **battery date** on top of the **battery** (Figure 2). The battery date tells if the battery must be charged.
2. If the **battery** is put into service *after* the **battery date**, the **battery** must be charged. See "How To Charge The Maintenance Free Battery".

## HOW TO CHARGE THE MAINTENANCE FREE BATTERY



**WARNING:** When you charge the battery, do not smoke. Keep the battery away from any sparks. The fumes from the battery acid can cause an explosion.

1. Remove the **battery**. See "How To Remove And Install The Battery" in the Customer Responsibilities section.
2. Use a 12 volt battery charger to charge the **battery**. Charge at a rate of 6 amperes for one hour. If you do not have a battery charger, have an authorized service center charge the battery.
3. Install the **battery**. See "How To Remove And Install The Battery" in the Customer Responsibilities section.

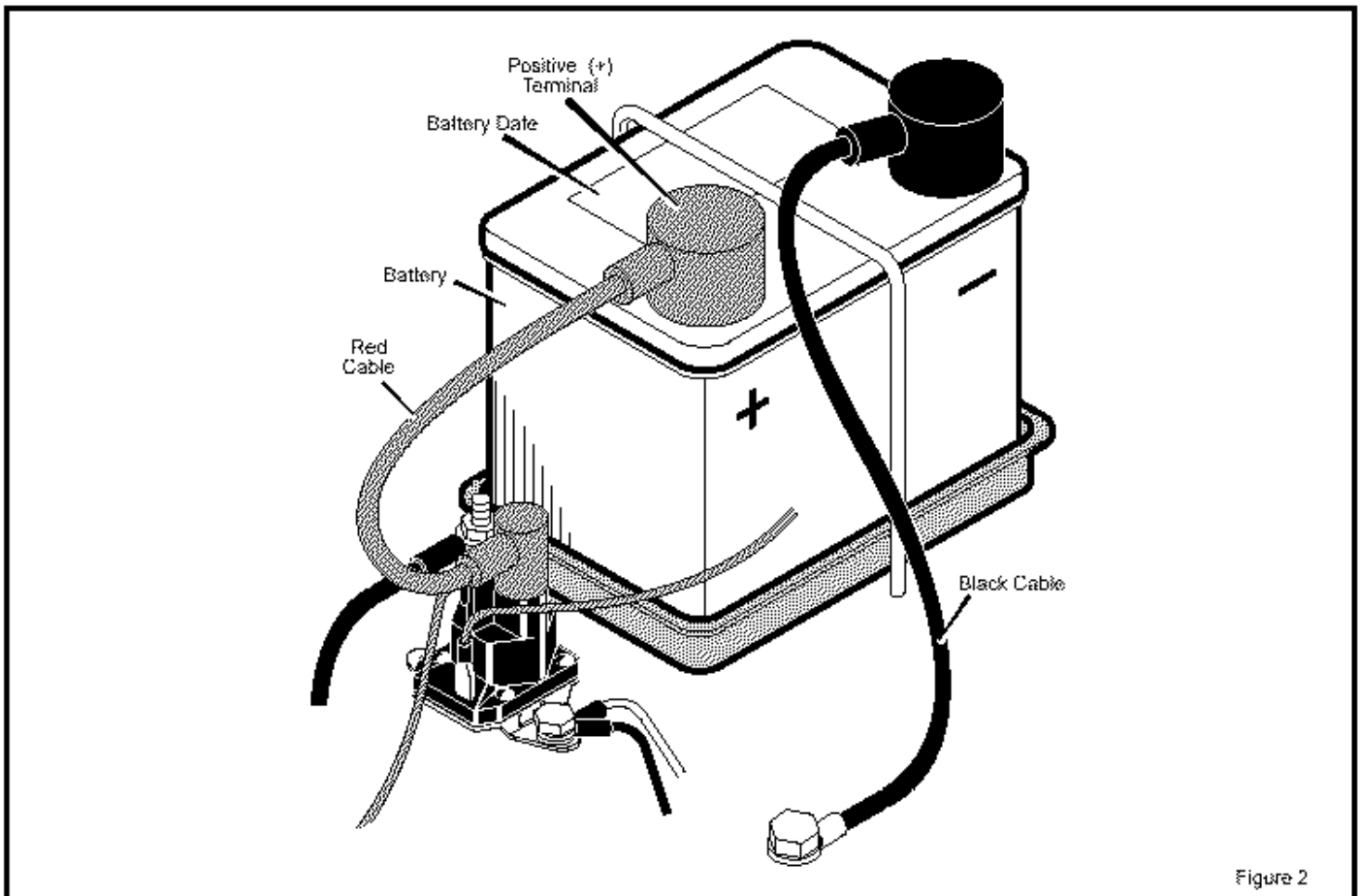
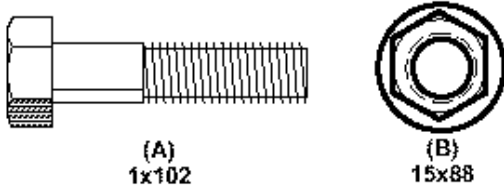

Figure 2

# ASSEMBLY

## HOW TO ASSEMBLE THE STEERING WHEEL

Use the fasteners shown below to install the **steering wheel**. The fasteners are shown at full size.



1. Make sure the front wheels point forward.
2. Some models have an *optional bellows*. Slide the **bellows** over the **steering post**. Make sure the **collar** of the **bellows** is on top (Figure 3).
3. Attach the **steering wheel** to the **steering post** with the fasteners. Tighten the fasteners.

**NOTE:** Make sure the steering wheel is tight. If the steering wheel is loose, tighten the fasteners.

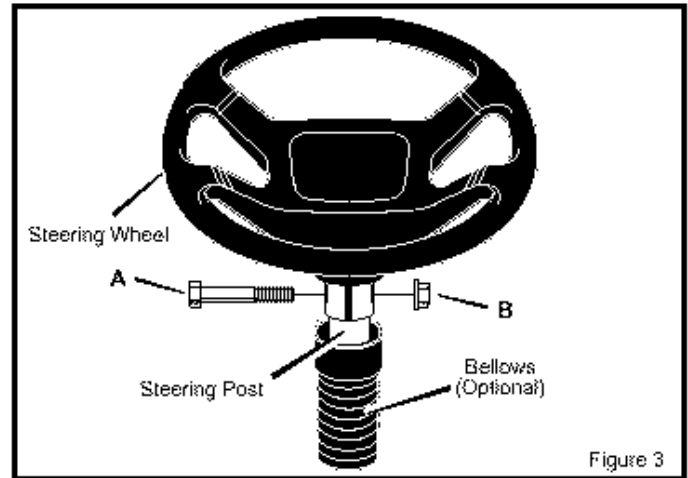

## CHECK THE TIRES

Check the air pressure in the tires. Tires with too much air pressure will cause the unit to ride rough. Also, the wrong air pressure will keep the mower housing from cutting level. The correct air pressure (PSI) is as follows.

Front Tires	22 PSI (1.5 BAR)
Rear Tires	14 PSI (1 BAR)

## CHECK THE DRIVE BRAKE

The drive brake can be easily checked as follows.

1. Set the parking brake. See page 13.
2. Move the shift lever to the neutral (N) position.
3. Push the unit.
4. If the rear wheels rotate, adjust the drive brake. See "How To Check And Adjust The Drive Brake" in the Customer Responsibilities section.

## CHECK THE BELTS

Move the lift lever to the lowest cutting height. Check the routing of the belts. Make sure the belts are not twisted. Make sure the belts are inside all the belt guides (Figure 4).

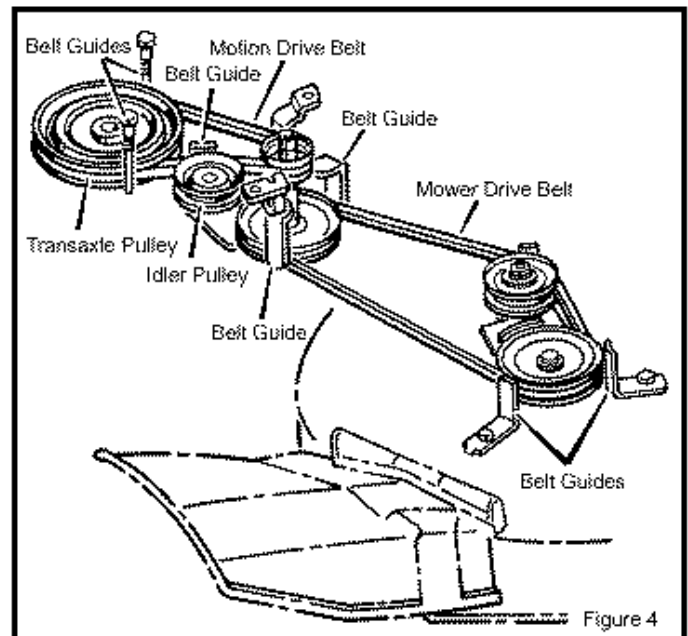

---

# ASSEMBLY

---

## HOW TO INSTALL THE SEAT

Use the fasteners shown below to install the **seat**. The fasteners are shown at full size.



1. Carefully remove the protective sleeve and the plastic bag from the **seat**. Do not damage the **wire** attached to the bottom of the **seat**.
2. Pivot the **seat hinge** to the position shown in Figure 5.
3. Align the holes in the **seat hinge** to the holes in the **seat** (Figure 5). Fasten the **seat** to the **seat hinge** with the fasteners as shown. Tighten the fasteners.
4. Check the operating position of the **seat**. If the **seat** needs to be adjusted, loosen the three nuts in the **seat bracket**. Slide the **seat bracket** forward or backward along the **seat adjusting holes** as shown. To keep the **seat** straight, tighten the rear nut and then tighten the two front nuts.
5. Fasten the **connector** to the **wire harness**. Make sure the **tab** on the **connector** locks into the **wire harness**.
6. Check the routing of the **wire harness**. Make sure the **wire harness** is between the **seat hinge** and the **seat bracket**.



**WARNING:** For correct and safe operation of the unit, fasten the connector to the wire harness. If the connector is not attached, the engine will stop when the attachment clutch is engaged.

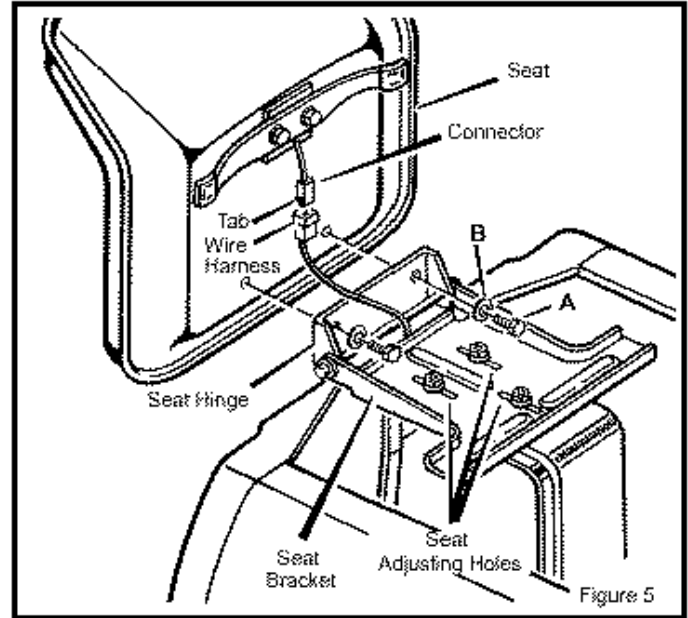

---

## CHECK THE LEVEL OF THE MOWER HOUSING

**NOTE:** After the unit is fully assembled, read the Operation section.

The level of cut was set at the factory. To check the level of cut, mow a short distance and look at the area that was cut. If the mower housing does not cut level, see the instructions on "How To Level The Mower Housing" in the Service And Adjustment section of this instruction book.

## OPERATION

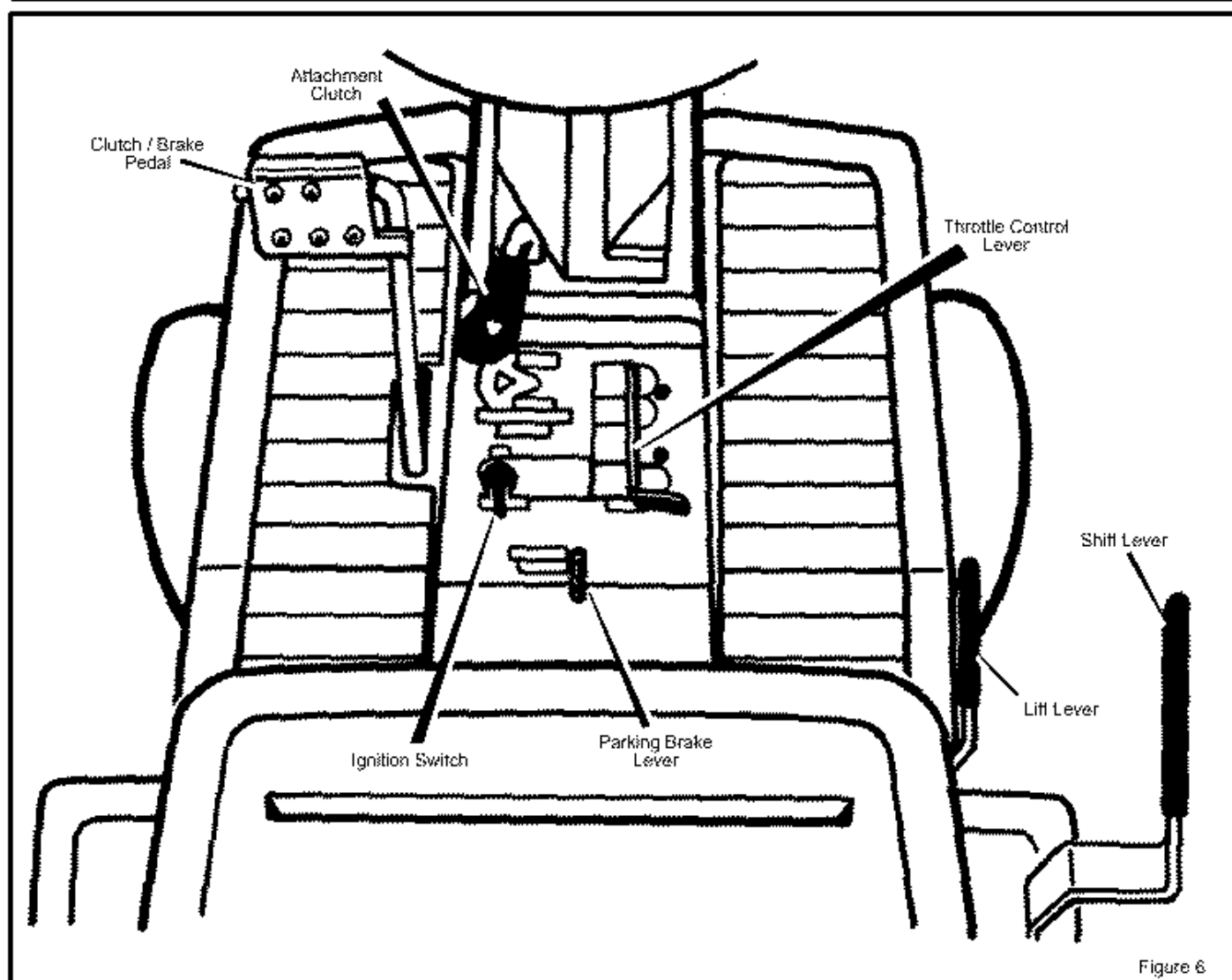

Figure 6



The operation of any lawn mower can result in foreign objects thrown in the eyes, which can result in severe eye damage. Always wear safety glasses or eye shields before starting your lawn mower and while mowing. We recommend the Wide Vision Safety Mask for over the spectacles or standard safety glasses, available at Sears Retail or Catalog Stores.

### LOCATION OF CONTROLS

**ATTACHMENT CLUTCH:** Use the attachment clutch to start and stop the rotation of the blade.

**CLUTCH / BRAKE PEDAL:** The pedal has two functions. The first function is a clutch. The second function is a brake.

**IGNITION SWITCH:** Use the ignition switch to start and stop the engine.

**LIFT LEVER:** Use the lift lever to change the height of cut.

**PARKING BRAKE LEVER:** Use the parking brake lever to engage the brake when you leave the unit.

**SHIFT LEVER:** Use the shift lever to change the speed of the unit.

**THROTTLE CONTROL LEVER:** Use the throttle control lever to increase or decrease the speed of the engine.

# OPERATION

## HOW TO USE THE THROTTLE CONTROL

Use the **throttle control** to increase or decrease the speed of the engine.

1. The FAST position is marked with a detent. For normal operation and when using a grass bagger, move the **throttle control** to the FAST position. For maximum charging of the battery and also for a cooler running engine, always operate the engine in the FAST position.
2. The engine governor is set at the factory for maximum performance. Do not adjust the governor to increase the speed of the engine.

## HOW TO USE THE ATTACHMENT CLUTCH

**Note:** If the engine stops when you engage the blade(s), the **seat switch is not activated**. Make sure you sit in the middle of the seat. Also, make sure the wire is connected to the seat switch.

The **attachment clutch** is next to the steering wheel (Figure 7). Use the **attachment clutch** to engage the blade(s).

1. Before you start the engine, make sure the **attachment clutch** is in the **DISENGAGE** position.
2. Move the **attachment clutch** to the **ENGAGE** position to rotate the blade(s).

3. Move the **attachment clutch** to the **DISENGAGE** position to stop the blade(s). Before you leave the operator's position, make sure the blade(s) has stopped rotating.
4. Before you ride the unit across a sidewalk or a road, move the **attachment clutch** to the **DISENGAGE** position.



**WARNING:** Always keep your hands and feet away from the blade, deflector opening, and the mower housing when the engine runs.

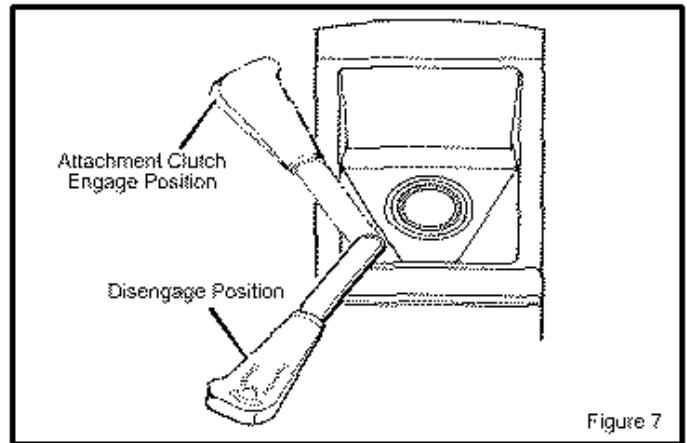

Figure 7

## HOW TO USE THE SHIFT LEVER

To change the forward speed or the direction of the unit, follow the steps below.

**CAUTION:** Before you move the shift lever, completely push the clutch/brake pedal forward to stop the unit. If the unit is not stopped, the gearbox can be damaged.

1. Completely push the clutch/brake pedal forward to stop the unit. Keep your foot on the pedal.
2. Move the throttle control lever to the SLOW position.
3. To move the **shift lever** to neutral (N) from a forward gear, pull the **shift lever** back and then move to the right (Figure 8).
4. To move the **shift lever** to a forward gear from neutral (N), pull the **shift lever** to the left and then push the **shift lever** forward.
5. SLOWLY release the clutch/brake pedal. Do not keep your foot on the pedal.

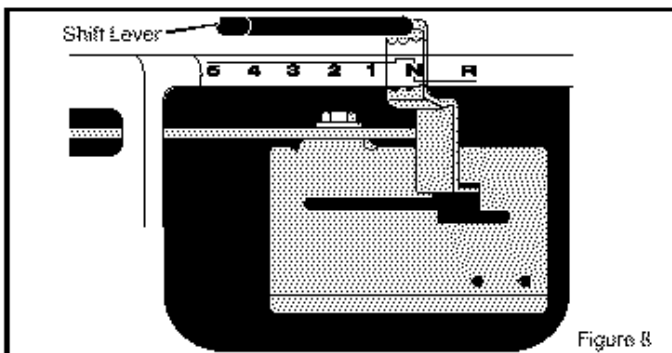

Figure 8

6. Move the throttle control to the FAST position.
7. To move the **shift lever** to reverse, stop the unit. Move the **shift lever** back to reverse (R).

**NOTE:** Belt noise can occur when the clutch is engaged. This noise is normal and does not affect the operation of the unit.

FUNCTION	SHIFT LEVER 5 Speeds	THROTTLE
Trimming	1	
Bagging Grass	1 or 2	
Mulching Grass	1 or 2	
Normal Mowing	2 or 3	
Easy Mowing	3 or 4	
Transport	5	
Pull Behind Attachments	2 or 3	

---

## OPERATION

---

### HOW TO SET THE PARKING BRAKE

1. Completely push the clutch/brake pedal forward.
2. Lift the **parking brake lever** (Figure 9).
3. Remove your foot from the clutch/brake pedal and then release the **parking brake lever**. Make sure the parking brake will hold the unit.
4. To release the parking brake, completely push the clutch/brake pedal forward. The parking brake will automatically release.



**WARNING:** Before you leave the operator's position, move the shift lever to the neutral (N) position. Set the parking brake. Move the attachment clutch to the DISENGAGE position. Stop the engine and remove the ignition key.

### HOW TO CHANGE THE CUTTING HEIGHT

To change the cutting height, raise or lower the **lift lever** as follows.

1. Move the **lift lever** down to lower the mower housing and up to raise the mower housing.
2. When you ride on a sidewalk or road, move the **lift lever** to the highest position and move the attachment clutch to the DISENGAGE position.

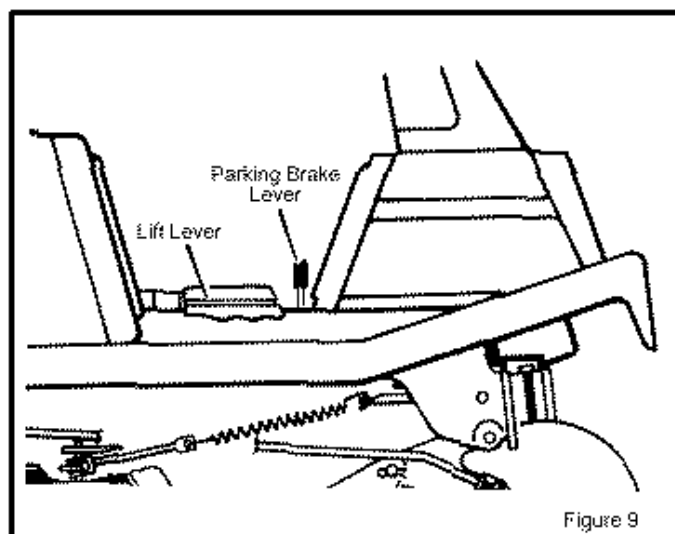

---

### HOW TO STOP THE UNIT

1. Completely push the **clutch/brake pedal** forward to stop the unit. Keep your foot on the pedal.
2. Move the attachment clutch to the DISENGAGE position.
3. Move the shift lever to the NEUTRAL position.
4. Set the parking brake.



**WARNING:** Make sure the parking brake will hold the unit.

5. Move the throttle control to the SLOW position.
6. To stop the engine, turn the ignition key to the OFF position. Remove the key.

---

### HOW TO TRANSPORT THE UNIT

To transport the unit, follow the steps below.

1. Move the attachment clutch to the DISENGAGE position.
2. Raise the lift lever to the highest position.
3. Move the throttle control to a position between SLOW and FAST.
4. To go faster, move the shift lever to a faster speed.

---

# OPERATION

---

## HOW TO OPERATE WITH THE MOWER HOUSING



**WARNING:** The deflector is a safety device. Do not remove the deflector. The deflector forces the discharged material toward the ground. Always keep the deflector in the down position. If the deflector is damaged, replace the deflector with an original equipment part from an authorized service center.

1. Start the engine.
2. Move the lift lever to a height of cut position.

**IMPORTANT:** In high or thick grass, cut the grass in the highest position first and then lower the mower housing to a lower position.

3. Move the throttle control to the SLOW position.
4. Move the attachment clutch to the ENGAGE position.
5. Push the clutch/brake pedal completely forward.

6. Move the shift lever to one of the speed settings.

**NOTE:** When you mow in heavy grass or mow with a bagger, put the shift lever in the slowest speed.

7. Slowly release the clutch/brake pedal.
8. Move the throttle control to the FAST position. If you need to go faster or slower, stop the unit and move the shift lever to another speed setting.
9. Make sure the level of cut is still correct. After you mow a short distance, look at the area that was cut. If the mower housing does not cut level, see the instructions on "How To Level The Mower Housing" in the Service And Adjustment section.



**WARNING:** For better control of the unit, always select a safe speed.

---

## HOW TO OPERATE THE UNIT ON HILLS



**WARNING:** Do not ride up or down slopes that are too steep to back straight up. Never ride the unit across a slope. See the "Slope Guide" in the back of this book for information on how to check slopes.

1. Before you ride up or down a hill, move the shift lever to the slowest speed.
2. Do not stop or change speed settings on a hill. If you must stop, quickly push the clutch/brake pedal forward and set the parking brake.

3. To start again, make sure the shift lever is in the slowest speed. Move the throttle control to the SLOW position. Slowly release the pedal.
4. If you must stop or start on a hill, always have enough space for the unit to roll when you release the brake and engage the clutch.
5. Be very careful when you change directions on a hill. When on a slope or in a turn on a hill, move the throttle control to the SLOW position to help prevent an accident.

# OPERATION

## BEFORE STARTING THE ENGINE

### CHECK THE OIL

**NOTE:** The engine was shipped from the factory filled with SAE 30 weight oil. Check the level of the oil. Add oil as needed.

1. Make sure the unit is level.

**NOTE:** Do not check the level of the oil while the engine runs.

2. Clean the area around the dipstick. Remove the dipstick. Wipe the oil from the dipstick.
3. Insert the dipstick into the oil fill tube. Turn the dipstick clockwise until it is tight. Remove the dipstick. Check the oil level on the dipstick. The oil level must reach the FULL mark on the dipstick.
4. If necessary, add oil until the oil reaches the FULL mark on the dipstick. The quantity of oil needed from ADD to FULL is shown on the dipstick. Do not add too much oil.

### ADD GASOLINE



**WARNING:** Always use a safety gasoline container. Do not smoke when adding gasoline to the fuel tank. Do not add gasoline when you are inside an enclosure. Before you add gasoline, stop the engine and let the engine cool for several minutes.

Fill the fuel tank with regular unleaded gasoline. Do not use premium unleaded gasoline. Make sure the gasoline is fresh and clean. Leaded gasoline will increase deposits and shorten the life of the valves.

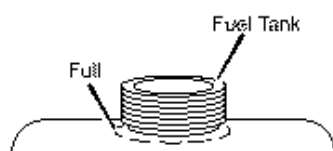

## HOW TO START THE ENGINE



**WARNING:** The electrical system has an operator presence system that includes a sensor switch mounted in the seat. These components tell the electrical system if the operator is sitting on the seat. This system will stop the engine when the operator leaves the seat if the attachment clutch is engaged. For your protection, always make sure this system operates correctly.

**NOTE:** The engine will not start unless you depress the clutch/brake pedal, move the shift lever to the neutral (N) position, and move the attachment clutch to the DISENGAGE position.

1. Sit in the middle of the seat. Push the clutch/brake pedal completely forward. Keep your foot on the pedal.
2. Move the shift lever to the neutral (N) position.

## HOW TO START WITH A WEAK BATTERY

If the battery is too weak to start the engine, the battery needs to be charged. If "Jumper Cables" are used to start the engine in an emergency, follow the procedure below.

**NOTE:** The unit is equipped with a 12 volt negative to ground system. Also, the other vehicle must have a 12 volt negative to ground system.



**WARNING:** Do not smoke. The fumes from the battery acid can cause an explosion. Keep the battery away from any flames or sparks. To prevent sparks, fasten the red "Jumper cable" to the positive (+) terminal before connecting the black "Jumper cable".

F-000614J

**CAUTION:** A mixture of alcohol (ethanol or methanol) and gasoline (called gasohol), will attract moisture and cause acid deposits during storage. While the unit is in storage, the acids in the fuel can damage the fuel system.

To prevent engine problems with the fuel system, empty the fuel system before storage of 30 days or longer as follows.

1. Drain the fuel tank.
2. Start the engine. Let the engine run until the fuel lines and the carburetor are empty.
3. After storage, make sure you use fresh fuel. See the storage instructions for additional information.
4. Never use engine cleaner or carburetor cleaner in the fuel tank or permanent damage can occur.

## CARBURETOR

The factory settings for the carburetor are for most conditions. If the engine is operated under the following conditions, you can adjust the carburetor mixture. See "How To Adjust The Carburetor" in the Service And Adjustment section.

1. The engine has a loss of power or does not run smooth.
  2. A change from summer to winter operation.
  3. A 40 degree change in the operation temperature. The carburetor was adjusted at 80 degrees at the factory.
  4. The engine is operated above 4,000 feet.
3. Make sure the attachment clutch is in the DISENGAGE position.
  4. Move the throttle control completely forward to the CHOKE or FAST position. Some models have a separate choke knob. Pull the choke knob to the full CHOKE position.
  5. Turn the ignition key to the START position. Release the key when the engine starts.
- NOTE:** If the engine does not start after four or five tries, move the throttle control to the FAST position. Again try to start the engine. If the engine will not start, see the TROUBLE SHOOTING CHART.
6. Slowly move the throttle control to the SLOW position. If model has a separate choke knob, push in the choke knob.
  7. Let a cold engine run for several minutes. Begin work when the engine is warm. To start a hot engine, move the throttle control to a position between FAST and SLOW.

**NOTE:** If the seat is raised when starting the engine, move the attachment clutch to the DISENGAGED position and engage the parking brake.

1. Connect each end of the RED "Jumper Cable" to the positive (+) terminals of each battery. Make sure you do not touch the chassis with the cables.
2. Connect one end of the BLACK "Jumper Cable" to the negative (-) terminal of the charged battery.
3. Connect the other end of the BLACK "Jumper Cable" to the mower's engine block.
4. Start the engine that has the weak battery last. Allow the engine to run.
5. To disconnect the "Jumper Cables", reverse the above steps.

# OPERATION

## HOW TO CHANGE THE MULCHER PLATE



**WARNING:** To prevent the engine from starting, disconnect the wire from the spark plug. Make sure the attachment clutch is in the **DISENGAGE** position.

The **mulcher plate** lets you mulch the grass for a clean, fine cut. To discharge the grass out the side or into a grass bagger, remove the **mulcher plate** as follows.

### How To Remove The Mulcher Plate

1. Raise the **deflector**. Remove the two wingnuts **B** and two carriage bolts **A** (Figure 10).

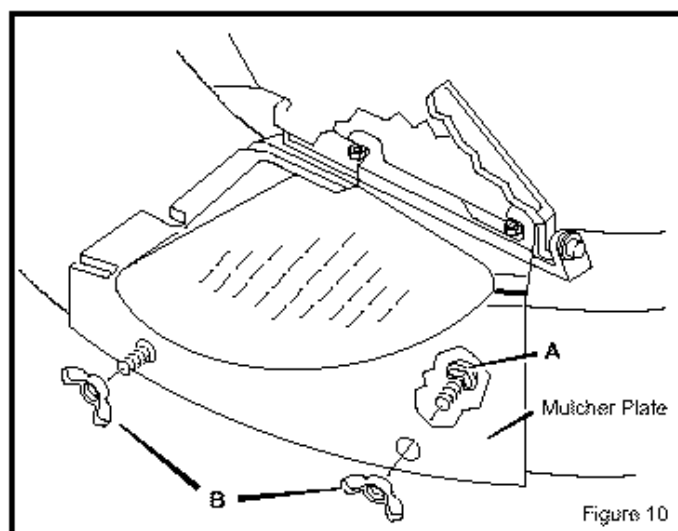

2. Slide the **mulcher plate** toward the front (Figure 11). Make sure the **tabs** on the **mulcher plate** are not locked behind the **nuts**.

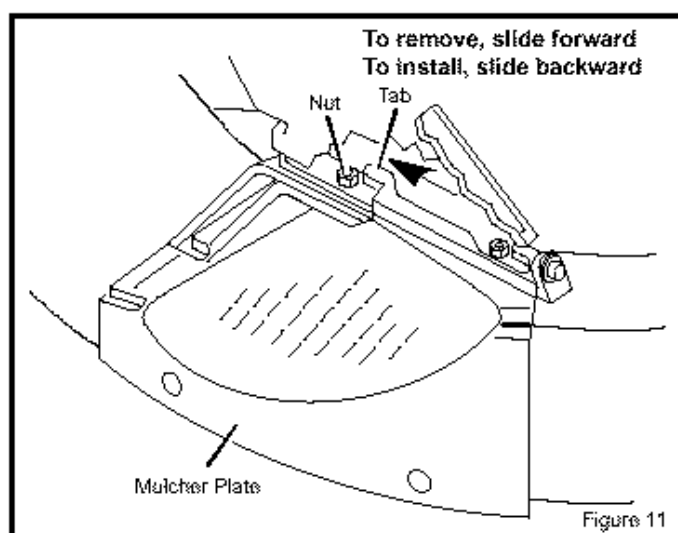

3. Lift the **mulcher plate** away from the mower housing (Figure 12).

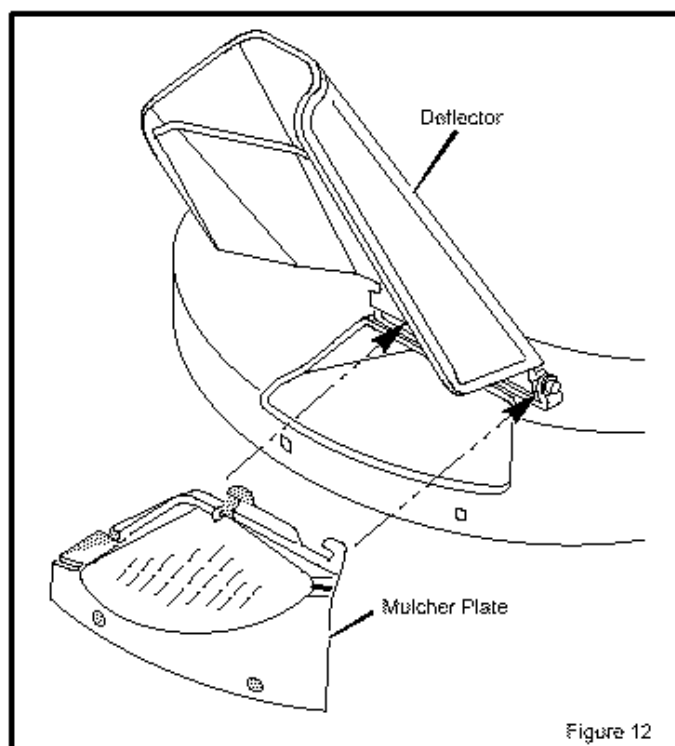

4. Attach wingnuts **B** and carriage bolts **A** to the **mulcher plate** for future use.

**IMPORTANT:** There are several different types of grass. Some types of grass are more difficult to cut. If you remove the mulcher plate and the grass does not discharge correctly, replace the blade with a standard blade. The part number of the standard blade is 56212E701.

### How To Install The Mulcher Plate

1. Remove wingnuts **B** and carriage bolts **A** from the **mulcher plate**.
2. Raise the **deflector**. Slide the **mulcher plate** under the **deflector** (Figure 12).
3. Push the **mulcher plate** to the rear. (Figure 11). Make sure the two **tabs** on the **mulcher plate** are locked around the two **nuts** for the deflector bracket.
4. Fasten the **mulcher plate** with two wingnuts **B** and two carriage bolts **A** (Figure 10).

# OPERATION

## OPERATING TIPS

1. Check the attachment clutch for correct adjustment. For the blade(s) to disengage correctly, the adjustment must be correct.
2. Before you use the unit, check the oil in the engine and add oil if necessary.
3. If the engine will not start, first make sure the wire is attached to the spark plug.
4. Make sure all the belts are inside all the belt guides. See the instructions on how to remove and install the motion drive and mower drive belts.
5. Before you make an inspection, adjustment (except for the carburetor) or repair, make sure the wire from the spark plug is disconnected.
6. Make sure the seat switch wire is connected. If the wire is not connected, the engine will not start.
7. For longer life of the battery, charge the battery every three months.
8. Use the shift lever to change the ground speed, not the throttle control.
9. Belt noise can occur when the blade or clutch is engaged. This noise is normal and does not affect the operation of the unit.
10. To move forward, always release the clutch/brake pedal slowly.

## MOWING AND BAGGING TIPS

1. For a lawn to look better, check the cutting level of the mower housing. See "How To Level The Mower Housing" in the Service And Adjustment section.
2. For the mower housing to cut level, make sure the tires have the correct amount of air pressure (PSI).
3. Every time you use the unit, check the blade. If the blade is bent or damaged, immediately replace the blade. Also, make sure the nut for the blade is tight.
4. Keep the blade(s) sharpened. A worn blade(s) will cause the ends of the grass to turn brown.
5. Do not cut or bag grass that is wet. Wet grass will not discharge correctly. Let the grass dry before cutting.
6. Use the left side of the mower housing to trim near an object.
7. Discharge the cut grass onto the mowed area. The result is a more even discharge of cut grass.
8. When you mow large areas, start by turning to the right so that the cut grass will discharge away from shrubs, fences, driveways, etc. After one or two rounds, mow in the opposite direction making left turns until finished (Figure 13).
9. If the grass is very high, cut two times to decrease the load on the engine. First cut with the mower housing in the highest position and then lower the mower housing for the second cut.
10. For better engine performance and an even discharge of the cut grass, always operate the engine with the throttle in FAST position.
11. When you use a bagger, operate the engine with the throttle in FAST position and the shift lever in first or second gear.
12. For better cutting performance and a quality cut, mow with the shift lever in one of the slower speeds.
13. After each use, clean the bottom and top of the mower housing for better performance. Also, a clean mower housing will help prevent a fire.

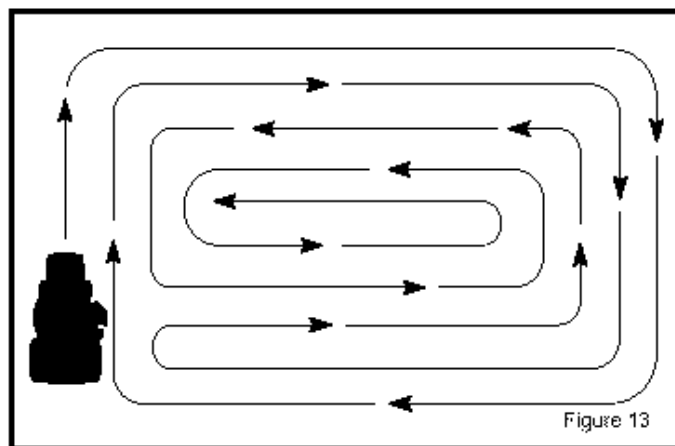

## MULCHING TIPS

When you use a mulcher attachment, the grass is cut into very small pieces. These small pieces will quickly break down. Because the nutrients are returned to the soil, the lawn will need less fertilizer. To correctly mulch the grass, follow the steps below.

1. Set the throttle in the FAST position. Operate the mower at a slower ground speed. If ground speed is too fast, the grass will not have an even cut.
2. Keep a sharp edge on the blade. A blade that is not sharp will cause the ends of the grass to become brown.
3. Make sure the grass is dry. Wet grass is difficult to cut.
4. Set the height of the mower housing so that only the top third of the grass is cut. If the grass is too high, set the height of the mower housing to the maximum height. Then, lower the mower housing for the second cut. Also, instead of using the full width of the mower housing, mulch at half the width.
5. Clean the bottom of the mower housing. Grass and other debris can keep the mower from working correctly.
6. If the grass grows fast, mulch more often.
7. If an area needs improvement, mulch a second time.

# CUSTOMER RESPONSIBILITIES

MAINTENANCE CHART							
	PROCEDURE	EACH USE	FIRST 2 HOURS	EVERY 25 HOURS	EVERY 50 HOURS	EVERY 100 HOURS	BEFORE STORAGE
<b>M O W E R</b>	Blade, Inspect and Sharpen			√			
	Attachment Clutch, Check			√			
	Brake, Check			√			
	Clutch, Check			√			
	Tires, Check			√			√
	Battery, Check and Charge			√			√
	Battery, Clean					√	√
	Lubrication					√	√
<b>E N G I N E</b>	Oil, Check	√					
	Cooling System, Clean	√					
	Oil, Change		√		√		√
	Air Filter, Clean				√		√
	Muffler, Check				√		
	Spark Plug, Check				√		√
	Fuel Filter, Replace (Remote Fuel Tanks Only)					√	
	Spark Plug, Replace					√	

## GENERAL RECOMMENDATIONS

1. The owner's responsibility is to maintain this product. This will extend the life of the product and is also necessary to maintain warranty coverage.
2. Check the spark plug, drive brake, lubricate the unit, and clean the air filter once a year.
3. Check the fasteners. Make sure all fasteners are tight.
4. Follow the Customer Responsibility and the Service And Adjustment section to keep the unit in good operating condition.



**WARNING:** Before you make an inspection, adjustment, or repair to the unit, disconnect the wire to the spark plug. Remove the wire from the spark plug to prevent the engine from starting by accident.

## CHECK THE TIRES

Check the air pressure in the tires. Tires with too much air pressure will cause the unit to ride rough. Also, the wrong air pressure will keep the mower housing from cutting level. The correct air pressure (PSI) is as follows. Semi-pneumatic front tires do not require air.

Front Tires	22 PSI (1.5 BAR)
Rear Tires	14 PSI (1 BAR)

# CUSTOMER RESPONSIBILITIES

## INSPECT BLADE



**WARNING:** Before you inspect or remove the blade, disconnect the wire to the spark plug. If the blade hits an object, stop the engine. Check the unit for damage. The blade has sharp edges. When you hold the blade, use gloves or cloth material to protect your hands.

If you keep the blade sharp and inspect the blade for damage, the blade will cut better and be more safe to operate. Frequently check the blade for excessive wear, cracks, or other damage. Frequently check the nut that holds the blade. Keep the nut tight. If the blade hits an object, stop the engine. Disconnect the wire to the spark plug. See if the blade is bent or damaged. Check the blade adapter for damage. Before you operate the unit, replace damaged parts with original equipment parts. See the authorized service center in your area. Every three years, have an authorized service person inspect the blade or replace the old blade with an original equipment part.

## HOW TO REMOVE AND INSTALL THE BLADE

1. Remove the mower housing. See the instructions on "How To Remove The Mower Housing".
2. Use a piece of wood to keep the blade from rotating.
3. Remove the nut that holds the blade (Figure 14).

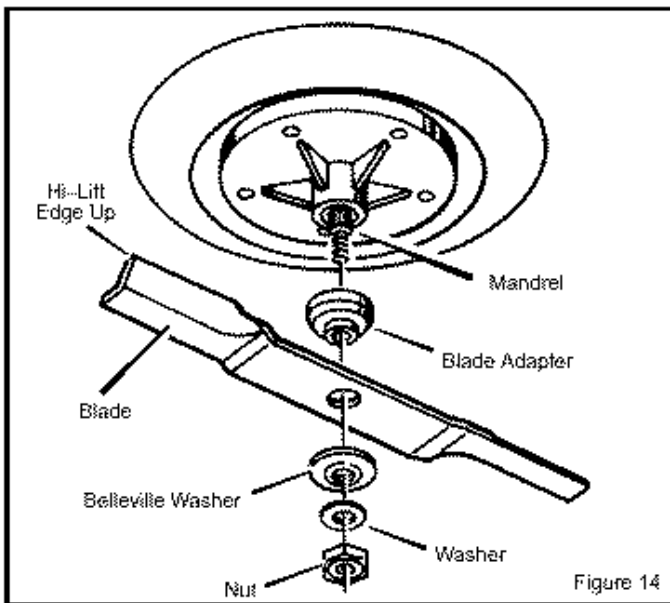

4. Check the blade and the blade adapter according to the instructions for "Inspect Blade". Replace a badly worn or damaged blade with an original equipment blade. See an authorized service center in your area.
5. Clean the top and bottom of the mower housing. Remove all the grass and debris.
6. Mount the blade and blade adapter on the mandrel (Figure 14).
7. Mount the blade so that the hi-lift edges are up. If the blade is upside down, the blade will not cut correctly and can cause an accident.
8. Fasten the blade with the original washers and nut. Make sure the outside rim of the Belleville washer is against the blade (Figure 15).



**WARNING:** Always keep the nut tight that holds the blade. A loose nut or blade can cause an accident.

9. Tighten the nut that holds the blade to a torque of 35 foot pounds (47.5 N-m).
10. Install the mower housing. See "How To Install The Mower Housing".

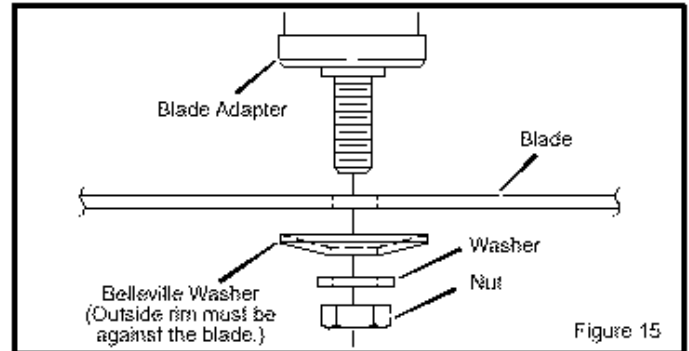

## HOW TO SHARPEN THE BLADE



**WARNING:** Vibration can be caused if the blade is not correctly balanced or if the blade is damaged. A blade that is damaged with cracks can break and cause an accident.

Keep a sharp edge on the blade. A blade that is not sharp will cause the tips of the grass to become brown.

1. Sharpen the blade two times a year or every 25 hours.
2. Remove the blade according to the instructions in "How To Remove And Install The Blade".
3. Clean the blade with a brush, soap and water. Check the blade. Look for cracks, nicks, or other damage. Replace a badly worn or damaged blade with an original equipment blade. See an authorized service center in your area.
4. Sharpen the blade with a file (Figure 16). Make sure you keep the original bevel angle.
5. Make sure the blade is balanced. Use a screwdriver and hold the blade parallel to the ground (Figure 16). A blade that is balanced will stay parallel to the ground. If the blade is not balanced, the heavy end will rotate toward the ground. Sharpen the heavy end until the blade is balanced.
6. A new blade will cut better than a badly worn blade. Every three years, have an authorized service person inspect the blade or replace the old blade with an original equipment blade.
7. Assemble the blade according to the instructions "How To Remove And Install The Blade".

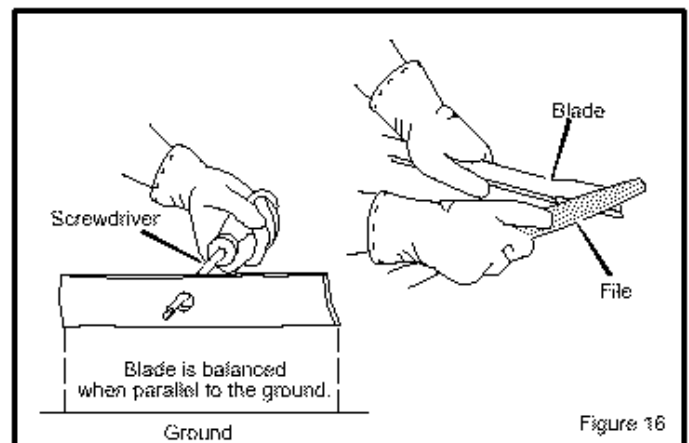

# CUSTOMER RESPONSIBILITIES

## HOW TO ADJUST THE ATTACHMENT CLUTCH



**WARNING:** To prevent an injury, the attachment clutch must operate correctly.

1. Stop the engine. Disconnect the wire from the spark plug.
2. Before you adjust the **attachment clutch**, check and level the mower housing. See "How To Level The Mower Housing." Make sure the mower housing is level before go to the next step.
3. Set the height of the mower housing in the lowest position.
4. Move the **attachment clutch** to the **DISENGAGE** position (Figure 17).
5. Check the **attachment clutch**. Before the **attachment clutch** engages, there must be 1/8" to 3/8" (3mm to 9mm) of free movement.
6. If an adjustment is needed, disconnect the **clevis** from the **pivot rod and bracket assembly** (Figure 18). Turn the **clevis** clockwise to decrease the free movement of the **attachment clutch**. Turn the **clevis** counterclockwise to increase the free movement.
7. Connect the **clevis** to the **pivot rod and bracket assembly**. Move the **attachment clutch** to the **DISENGAGE** position. Check the free movement of the **attachment clutch**.
8. Check the operation of the **blade brake**. Rotate the **pulley** with your hand. Make sure that the blade brake pad presses tightly against the **pulley**.
9. Move the **attachment clutch** to the **ENGAGE** position. Check the pad for the **blade brake**. If the pad is excessively worn or damaged, replace the **brake pad** assembly. Correct replacement parts and assistance are available from an authorized service center.

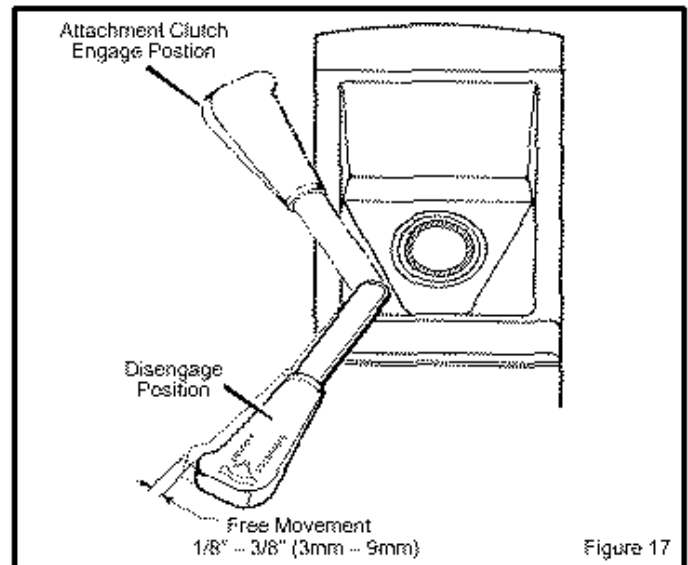

10. Attach the wire to the spark plug. Mow for a short distance and again check the operation of the **attachment clutch**.
11. When you move the **attachment clutch** to the **DISENGAGE** position, all movement will stop within five seconds if the adjustment is correct. If there is movement of the belt or the blade continue to rotate, engage and disengage the **attachment clutch** five times to remove any excess rubber from a new **mower drive belt**. If there is still blade rotation from the **DISENGAGED** position, again adjust the **attachment clutch** beginning with the first step. If you need assistance, take the unit to an authorized service center.
12. If you replace the **mower drive belt**, adjust the **attachment clutch**.

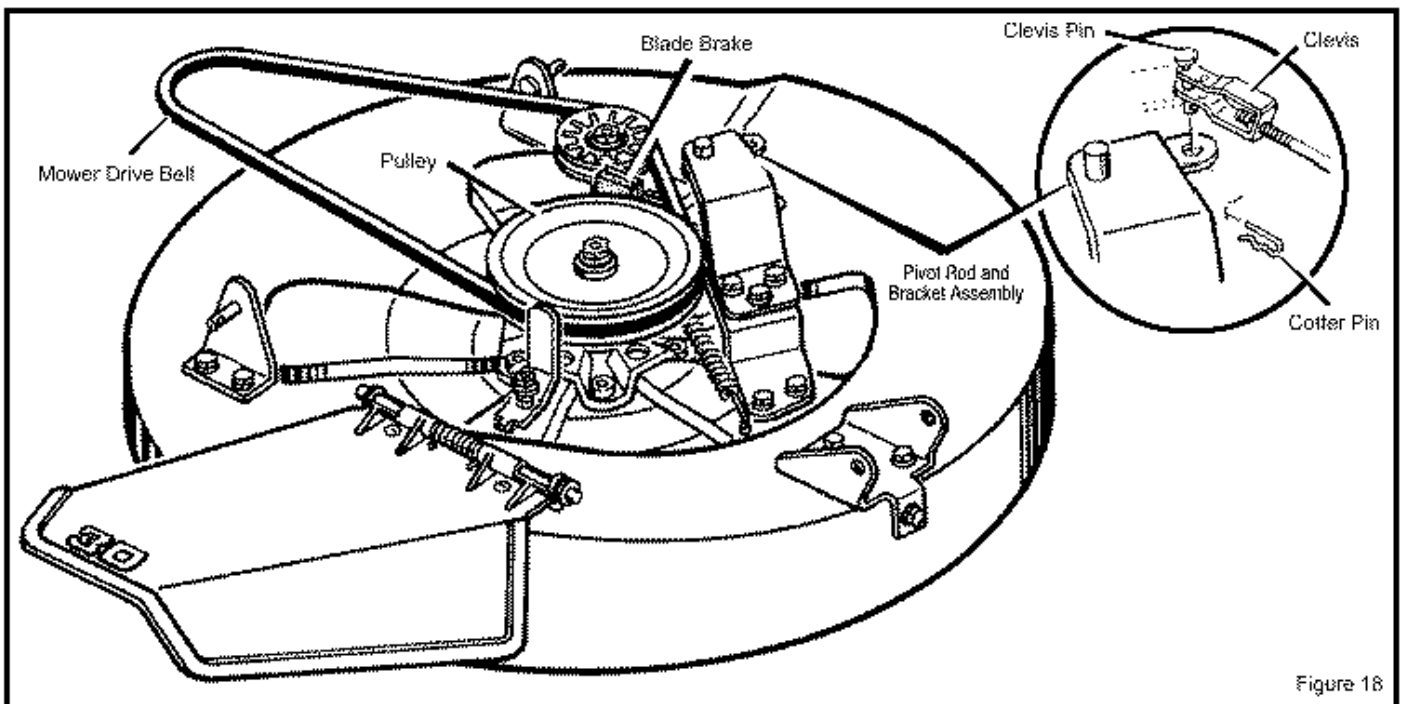

# CUSTOMER RESPONSIBILITIES

## HOW TO CHECK AND ADJUST THE DRIVE BRAKE

1. Before you adjust the brake, check the clutch adjustment. See the instructions on "How To Check And Adjust The Clutch".
  2. Make sure the shift lever is in the neutral (N) position.
  3. Disconnect the **adjustable nut** from the **brake arm** (Figure 20).
  4. Push the **brake arm** forward and hold in position.
  5. With the **brake arm** forward, rotate the **adjustable nut** **counterclockwise** on the **brake rod** until the **adjustable nut** is in line with hole in the **brake arm**.
- NOTE: If the adjustable nut will not line up with the hole in the brake arm, go to step 6. If the adjustable nut does line up with the hole in the brake arm, go to step 12.**
6. Pull the **brake arm** to the rear of the unit.
  7. The brake adjustment of the **transaxle** is located on the underside of the transaxle (Figure 19). Use one wrench to hold the **brake stud** and another wrench to hold the **hex nut**. Loosen the **hex nut** approximately 2 turns.
  8. Turn the **brake stud** clockwise 1/2 turn. Try to push the unit. If the unit rolls, again turn the **brake stud** clockwise 1/2 turn. Continue this adjustment until you feel resistance from the brake when you push the unit.
  9. Turn the **brake stud** counterclockwise one turn. Then, hold the **brake stud** with one wrench while you tighten the **hex nut** with another wrench.
  10. Push the **brake arm** forward and hold in position.
  11. With the **brake arm** forward, rotate the **adjustable nut** clockwise until the **adjustable nut** is in line with the hole in the **brake arm**.
  12. Connect the **adjustable nut** to the **brake arm** with the **washer** and **cotter pin**.
  13. Apply the parking brake. Try to push the unit. If the rear wheels do not turn, the brake is correctly adjusted. Release the parking brake. Push the unit to see if the wheels will freely roll.



**WARNING:** If you cannot correctly adjust the drive brake, take the unit to an Authorized Service Center.

## HOW TO CHECK AND ADJUST THE CLUTCH

If the motion drive belt is loose, the clutch will slip when: (1) going up a hill, (2) pulling a heavy load, or (3) the unit will not move forward. Check the clearance at the rear of the **pedal lever** (Figure 20). If the motion drive belt is loose, the clearance will be less than 1/2 inch and the clutch will slip. Adjust the clutch as follows.

1. Disconnect the **adjustable nut** from the idler bracket (Figure 20).
2. Turn the **adjustable nut** **clockwise** to increase the length of the **clutch rod**. This adjustment will increase the clearance at the **pedal**.
3. Connect the **adjustable nut** to the **idler bracket** with the **washer** and **cotter pin**. Check the clearance at the **pedal**. There must be 1/2 to 5/8 inch clearance at the back of the **pedal**.
4. After making an adjustment to the **pedal**, check the **brake rod** as described in the instructions, "How To Check And Adjust The Drive Brake".

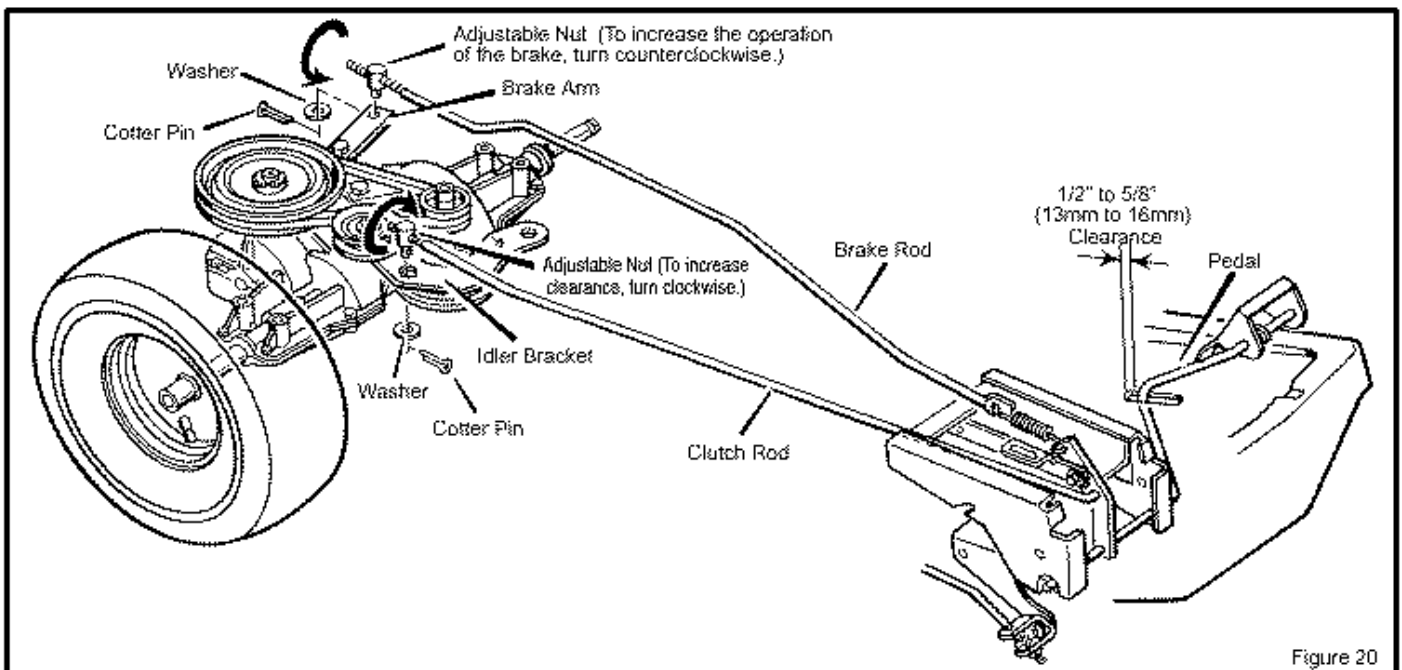
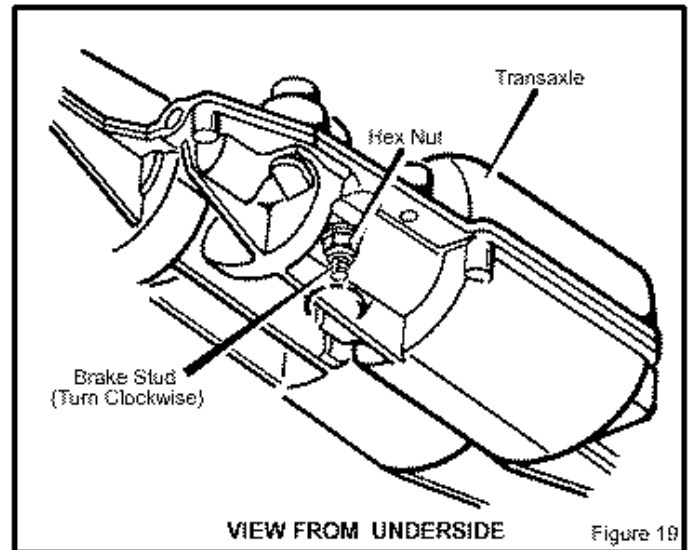

Figure 20

# CUSTOMER RESPONSIBILITIES

## HOW TO REMOVE THE SIDE PANEL

To help service the engine or the battery, each **side panel** can be easily removed.

1. Remove the **screws** that hold the back of the **side panel** (Figure 21).
2. Remove the large **screws** that hold the front of the **side panel** (Figure 22).
3. Slide the **side panel** back approximately one inch. Remove the **side panel**.

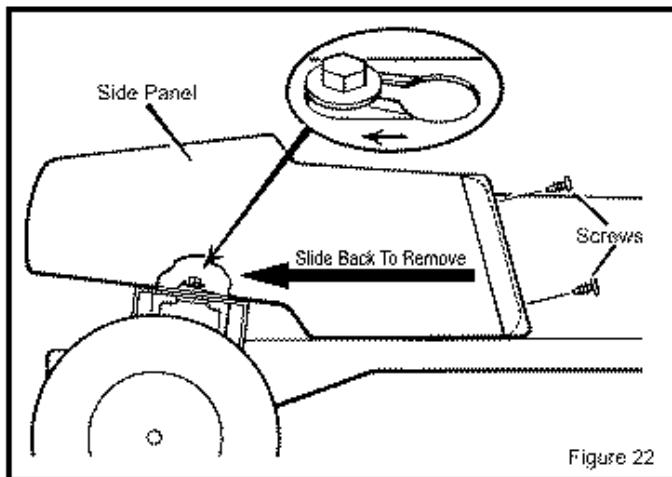
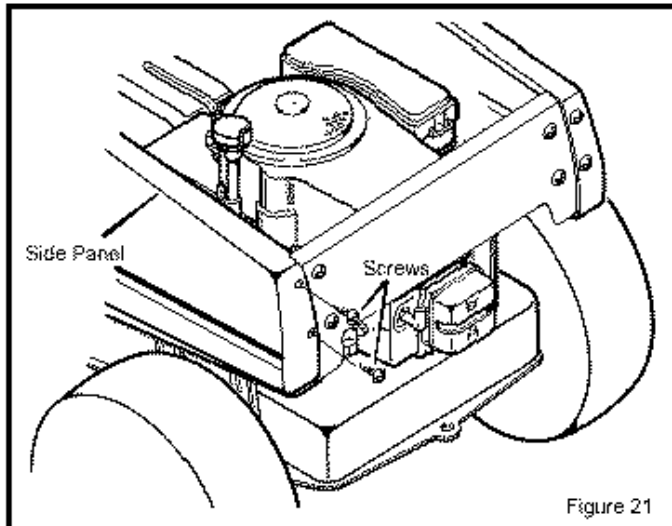

## BATTERY SERVICE

### HOW TO REMOVE AND INSTALL THE BATTERY

To charge or clean the **battery**, remove the **battery** from the unit as follows.



**WARNING:** To prevent sparks, disconnect the black battery cable from the negative (-) terminal before you disconnect the red cable.

**WARNING:** The battery contains sulfuric acid which is harmful to the skin, eyes and clothing. If the acid gets on the body or clothing, wash with water.

F-000614J

1. Remove the **black cable** from the negative (-) terminal (Figure 23).
2. Remove the **red cable** from the **positive (+) terminal**.
3. Remove the **battery clamp** from the battery.
4. Remove the **battery** from the unit.
5. To install the **battery**, reverse the above steps.

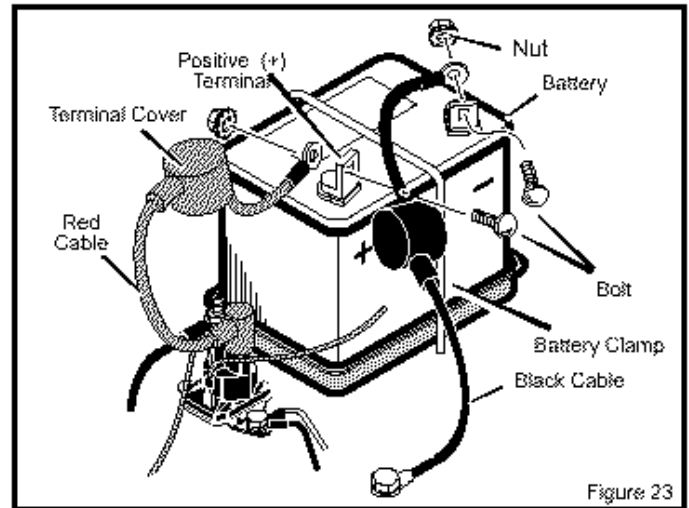

### HOW TO CHARGE THE BATTERY



**WARNING:** When you charge the battery, do not smoke. Keep the battery away from any sparks. The fumes from the battery acid can cause an explosion.

1. For longer life of the **battery**, charge the **battery** every three months.
2. Before you charge the **battery**, remove the **battery**.
3. To charge the **battery**, use a 12 volt battery charger. Charge at a rate of 3 amperes for 2 to 3 hours.
4. Install the **battery**.

### HOW TO CLEAN THE BATTERY

1. Remove the **battery**.
2. Wash the **battery** with a solution of one gallon of water and four tablespoons of baking soda (sodium bicarbonate). Make sure the solution does not get into the battery cells.
3. Clean the **terminals** and the ends of the **cables** with a wire brush.
4. Install the **battery**.
5. To prevent corrosion, apply grease to the **battery terminals**.

# CUSTOMER RESPONSIBILITIES

## WHERE TO LUBRICATE



Lubricate the areas shown with engine oil.



Apply grease with a brush to the areas shown.

**NOTE:** Apply grease to the steering gear assembly.

**CAUTION:** If the unit is operated in dry areas that have sand, use a dry graphite spray to lubricate the unit. Do not lubricate the nylon bearings for the front wheels. Oil or grease will damage the bearings.

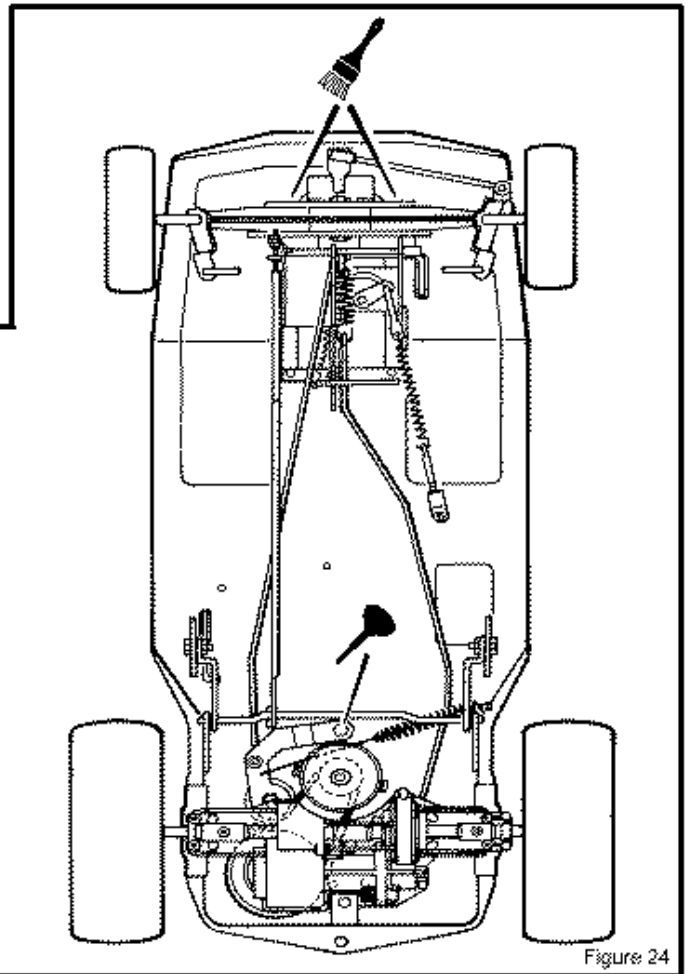
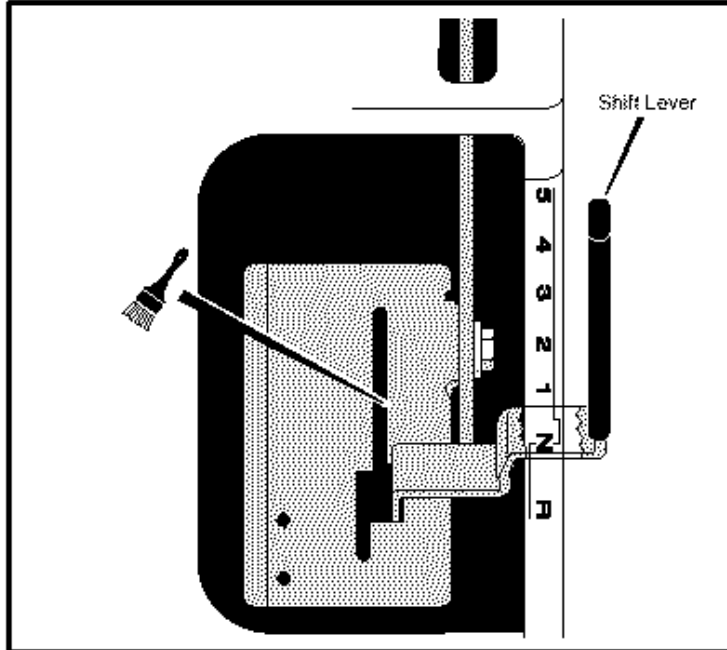

Figure 24

# CUSTOMER RESPONSIBILITIES

## ENGINE

### HOW TO CHECK THE OIL

**NOTE:** Do not check the level of the oil while the engine runs.

1. Make sure the unit is level.
2. Clean the area around the **dipstick** (Figure 25). Remove the **dipstick**. Wipe the oil from the **dipstick**.
3. Insert the **dipstick** into the oil fill tube. Turn the **dipstick** clockwise until it is tight. Remove the **dipstick**. Check the oil level on the **dipstick**. The oil level must reach the FULL mark on the **dipstick**.
4. If necessary, add oil until the oil reaches the FULL mark on the **dipstick**. The quantity of oil needed from ADD to FULL is shown on the **dipstick**. Do not add too much oil.

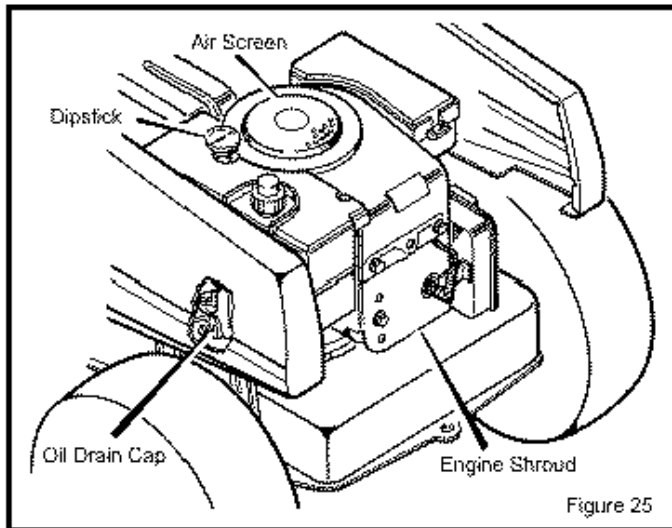

### HOW TO CHANGE THE OIL

**NOTE:** Do not drain the oil from a cold engine. Before you drain the oil, let the engine run for several minutes. Make sure you do not get oil on the belts.

1. Remove the oil **drain cap**. Drain the oil completely from the engine. Install and tighten the **oil drain cap**.
2. Only use a high quality detergent oil rated with API service classification SG. Select the oil's SAE viscosity grade according to the expected operating temperature using the temperature chart below:

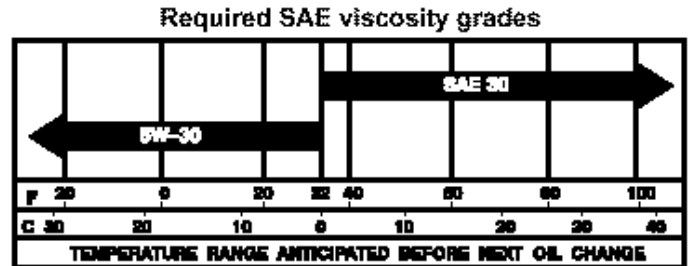

**NOTE:** Although multi-viscosity oils (5W30, 10W30, etc.) improve starting in cold weather, these multi-viscosity oils will result in increased oil consumption when used above 32° F. Check the engine oil level more frequently to avoid possible engine damage from running low on oil.

3. Clean the area around the **dipstick**. Remove the **dipstick**. Slowly pour approximately 32 ounces (1 quart) of oil into the oil extension tube.
4. Insert the **dipstick** into the oil extension tube. Turn the **dipstick** in a clockwise direction until it is tight. Remove the **dipstick**. Check the oil level on the **dipstick**. The oil level must reach the FULL mark on the **dipstick**.

### HOW TO CLEAN THE COOLING SYSTEM

The engine is air cooled. The air that cools the engine enters through the **air screen** on top of the engine. Clean the engine every 100 hours or every year as follows.

1. Remove any grass, dirt or debris from the **air screen** with a cloth or brush.
2. Inspect the edge of the **engine shroud** for grass or debris. Remove any grass or debris visible at the bottom edge of the **engine shroud**.

### HOW TO CHECK THE MUFFLER

Check the muffler every 50 hours. Make sure the muffler is correctly mounted and is not loose. If the muffler is worn or burnt, replace with a new muffler. A worn muffler is a fire hazard and can damage the engine.

If you mount a spark arrester to the muffler, also check the spark arrester when you check the muffler. If the spark arrester is worn or damaged, replace it with a new spark arrester. See your nearest authorized service center for a spark arrester.

## CUSTOMER RESPONSIBILITIES

### HOW TO CLEAN THE AIR FILTERS

Some engines have two filters, an outer **foam filter** around an inner **paper filter**. Clean the air filters every 50 hours. If you operate in dirty conditions, service more often.

**NOTE:** Never run the engine with the air filters removed. The air filters will help protect the engine against wear. For the correct replacement filter, see the parts list for the engine.

1. Remove the two **wingnuts** from the **cover** (Figure 26).
2. Remove the **cover** from the air cleaner.
3. Remove the two **nuts** from the filters.
4. Remove the air filters.
5. Clean the inside of the **base** and the **cover** with a cloth.
6. Remove the **foam filter** from the **paper filter**.
7. If equipped, wash the **foam filter** in a detergent and water solution. To remove the water solution, tightly roll the **foam filter** in a dry cloth. Remove the **foam filter** from the cloth. Completely dry the **foam filter**.  
**CAUTION:** Do not wash the filters in gasoline or other solvents that will burn.
8. Evenly apply SAE 30W oil to the dry **foam filter**.
9. To clean the **paper filter**, lightly tap the **paper filter** against a hard flat surface.
10. If the **paper filter** is very dirty, replace the **paper filter**.

11. Assemble the air filters with the two **nuts**.
12. Install the **cover**. Fasten the **cover** with the two **wingnuts**.

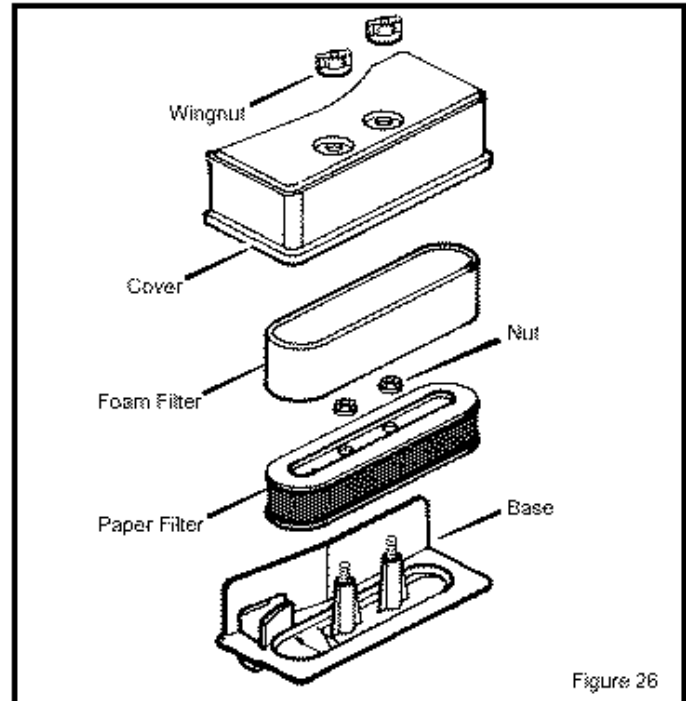

### HOW TO CHECK THE SPARK PLUG

1. Check the gap of the **spark plug** with a **feeler gauge** (Figure 27). The correct gap is **0.030"**.
2. For easy starting and good performance, replace the **spark plug** every two years.

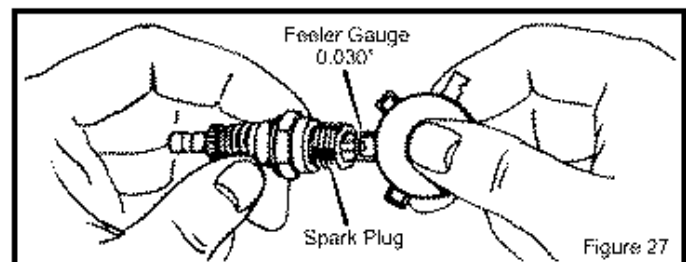

# SERVICE AND ADJUSTMENT

## HOW TO ADJUST THE THROTTLE CONTROL

For the best engine performance, set the throttle control as follows.

1. Move the **throttle control** to the **FAST** position (Figure 28).
2. Loosen the **clamp screw** so that the **throttle control cable** can move in the **cable clamp** (Figure 29). Do not remove the **cable clamp** or disconnect the **throttle control cable** from the **engine control lever**.
3. Move the **engine control lever** until the slot in the lever is aligned (lines up) with the hole in the **control bracket** as shown.
4. Tighten the **clamp screw**. Move the **throttle control** to the **SLOW** position and then back to the **FAST** position. Check the alignment of the **throttle control lever**. See step 3.
5. The **throttle control** is now set at the correct speed. When the **throttle control** is at the **FAST** position, the engine speed is 3400 + or - 100 RPM. When the **throttle control** is in the **SLOW** position, the engine speed is 2150 + or - 100 RPM.

**IMPORTANT:** Do not change the engine governor. If the engine governor needs an adjustment, go to the nearest Authorized Service Center. They have the equipment and experience to make the adjustment.

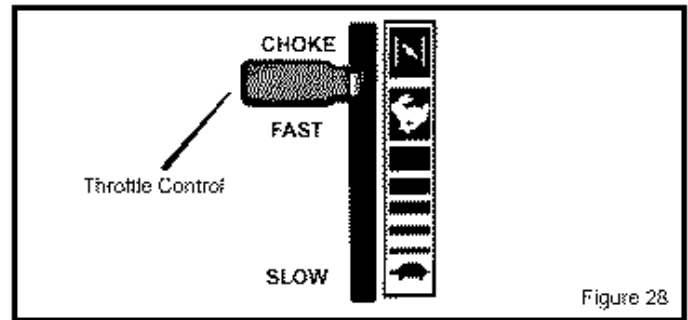

Figure 28

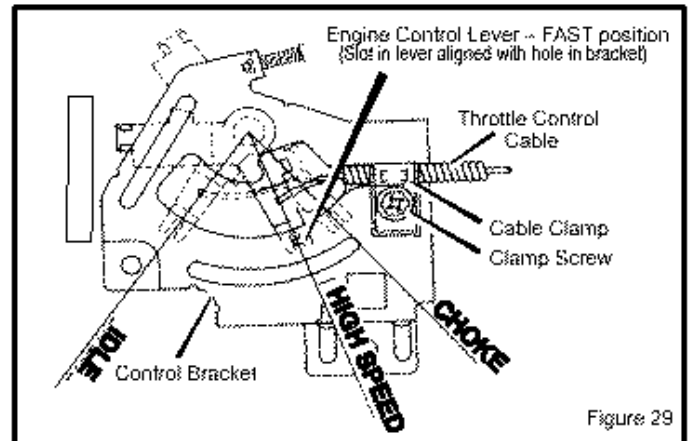

Figure 29

# SERVICE AND ADJUSTMENT

## HOW TO REMOVE THE MOWER HOUSING

1. Move the **lift lever** to the middle position.
2. Move the **attachment clutch** to the DISENGAGE position (Figure 30).
3. Disconnect the **blade drive link** from the **pivot rod and bracket assembly**. See illustration "C".
4. Remove the hair pins from the **adjuster plates**. See illustrations "A" and "B".
5. Move the mower housing to the left until the right side **adjuster plate** separates from the **hanger**. See illustration "A".
6. Move the mower housing to the right until the left side **adjuster plate** separates from the **hanger**. See illustration "B".
7. Remove the **long pin** from the **front hanger**. See illustration "D".
8. Remove the **mower drive belt** from the **stack pulley**. Slide the **mower drive belt** between the **stack pulley** and the **belt guide**.
9. Completely turn the steering wheel to the right. Pull the mower housing away from the left side of the unit.

## HOW TO INSTALL THE MOWER HOUSING

1. Completely turn the steering wheel to the right. Push the mower housing under the left side of the unit.
2. Slide the **mower drive belt** between the **stack pulley** and the **belt guide**. Put the **mower drive belt** around the **stack pulley**. Make sure the "V" side of the **mower drive belt** is against the **stack pulley**. Also, make sure the **mower drive belt** is not twisted.
3. Attach the **mower housing** to the **front hanger** with the **long pin**. Fasten with the washer and hair pin. See illustration "D".
4. Attach the **adjuster plates** to the **hangers** with the hair pins. See illustrations "A" and "B".
5. Connect the **blade drive link** to the **pivot rod and bracket assembly** with the fasteners. See illustration "C".
6. Move the **attachment clutch** to the ENGAGE position. Make sure the **mower drive belt** is inside all the **belt guides**.
7. Make sure the mower housing is level. See the instructions on "How To Level The Mower Housing".
8. Check the operation of the **attachment clutch**. See the instructions on "How To Adjust The Attachment Clutch".

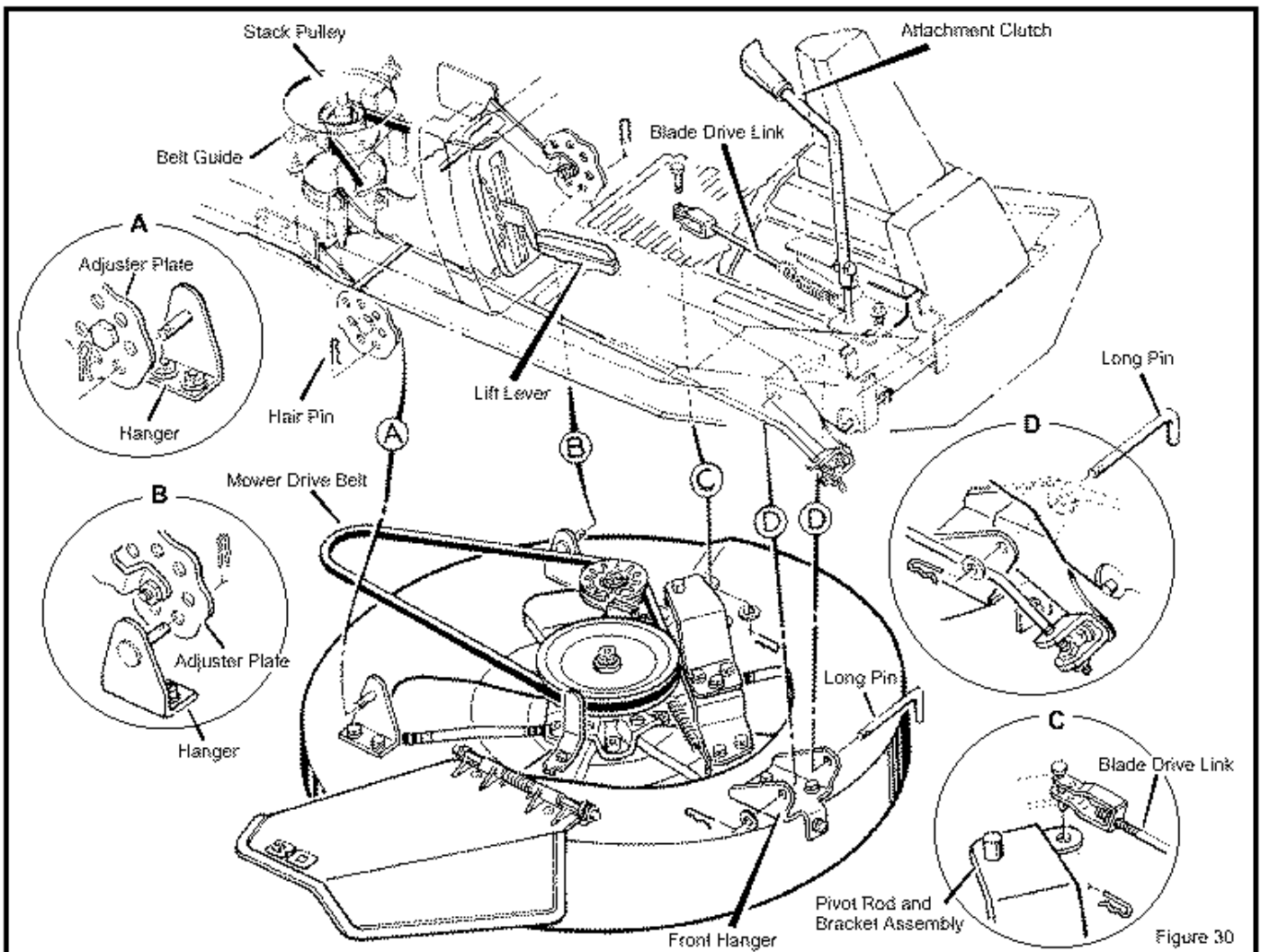

Figure 30

# SERVICE AND ADJUSTMENT

## HOW TO LEVEL THE MOWER HOUSING

If the mower housing is level, the blade will cut easier and the lawn will look better.



**WARNING:** Before you make an inspection, adjustment, or repair to the unit, disconnect the wire to the spark plug. Remove the spark plug wire to prevent the engine from starting by accident.

1. Make sure the unit is on a hard level surface.
2. Check the air pressure in the tires. If the air pressure is incorrect, the mower housing will not cut level. Make sure the rear tires are inflated to 14 psi. (1 BAR) and the front tires to 22 psi. (1.5 BAR).
3. Move the lever for the attachment clutch to the ENGAGE position. Move the lift lever to the middle position.
4. There are two adjustment procedures below that will level the mower housing.

## THE SIDE TO SIDE ADJUSTMENT

There are measuring points on the mower housing indicated by small round dimples **A**, **B**, **C**, and **D** shown in Figure 31. To determine if an adjustment is needed, use a ruler and measure the distance from the level surface to the bottom of the mower housing at points **C** and **D**. In correct adjustment, the mower housing at points **C** and **D** must be within  $\frac{1}{4}$ " (6 mm) of the same height. If the difference in the measurement is more than  $\frac{1}{4}$ " (6 mm), adjust as follows.

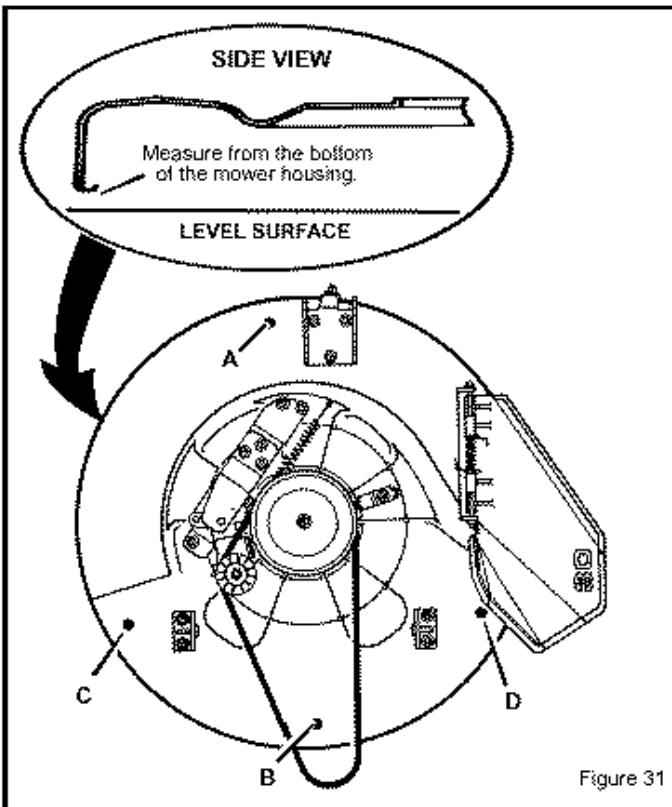

Figure 31

1. Disconnect one or both **adjuster plates** from the **hangers** (Figure 32).
2. The higher number holes in the **adjuster plates** will raise the height of the mower housing. The lower number holes will lower the mower housing.
3. Connect the **adjuster plates** to the **hangers** in the holes that will level the mower housing. Fasten the **adjuster plates** with the **hair pins**.
4. Check the housing for the correct adjustment. If necessary, repeat the adjustment.

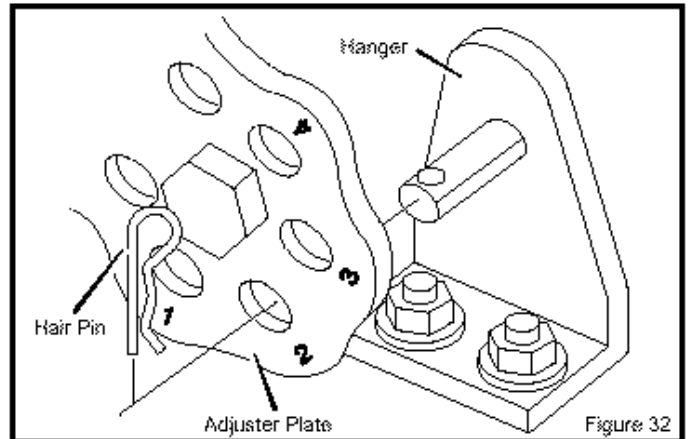

Figure 32

## THE FRONT TO BACK ADJUSTMENT

To determine if an adjustment is needed, use a ruler and measure the distance from the level surface to the bottom of the mower housing at points **A** and **B**. In correct adjustment, the front of the mower housing at point **A** will be  $\frac{1}{8}$ " to  $\frac{3}{8}$ " (3mm to 9mm) lower than the back of the mower housing at point **B**. Adjust as follows.

1. Loosen the **jam nut** (Figure 33).
2. Turn the **locknut** clockwise to raise the front of the mower housing. Turn the **locknut** counterclockwise to lower the front of the mower housing.
3. Check the housing for the correct adjustment. If necessary, repeat the adjustment.
4. Tighten the **jam nut**.
5. Connect the wire to the spark plug.

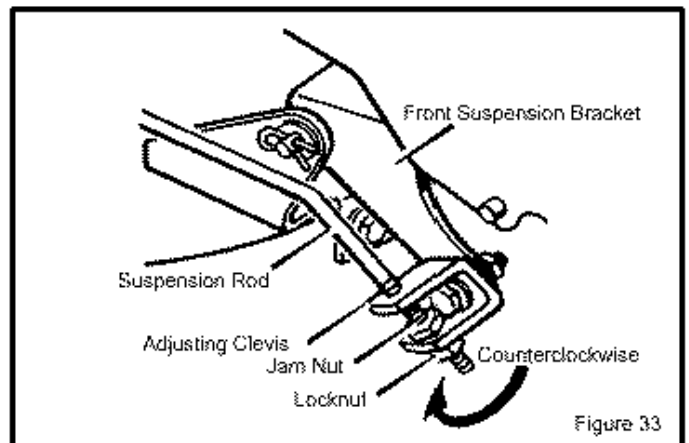

Figure 33

# SERVICE AND ADJUSTMENT

## HOW TO REPLACE THE MOTION DRIVE BELT

### REMOVAL

1. Remove the mower housing. See the instructions on "How To Remove The Mower Housing".
2. Completely push the clutch/brake pedal forward and engage the parking brake.
3. Try to pull the motion drive belt off the **drive pulley**. If the **belt guides** are too close to the **drive pulley**, loosen the **belt guides** (Figure 35).
4. Remove the motion drive belt from the **idler pulley**.
5. Pull the motion drive belt toward the front of the unit.
6. Remove the motion drive belt from the **stack pulley**. If necessary, loosen the **belt guide** at the **stack pulley**. A correct replacement part or assistance is available from an authorized service center in your area.

### INSTALLATION

1. Slide the motion drive belt between the **stack pulley** and the **belt guide**. Install the motion drive belt on the top pulley of the **stack pulley**. Make sure the "V" side of the belt is against the pulley (Figure 34).

2. Slide the motion drive belt between the **belt retainer** and **idler pulley**. Make sure the flat side of the motion drive belt is against the **idler pulley**. Also, make sure the belt is not twisted.
3. Install the motion drive belt around the **drive pulley**.
4. Make sure the motion drive belt is inside all the **belt guides**.
5. Make sure all the **belt guides** are tight.
6. Before you use the unit, check the adjustment of the clutch. See the instructions "How To Check And Adjust The Clutch".
7. Install the mower housing. See the instructions "How To Install The Mower Housing".

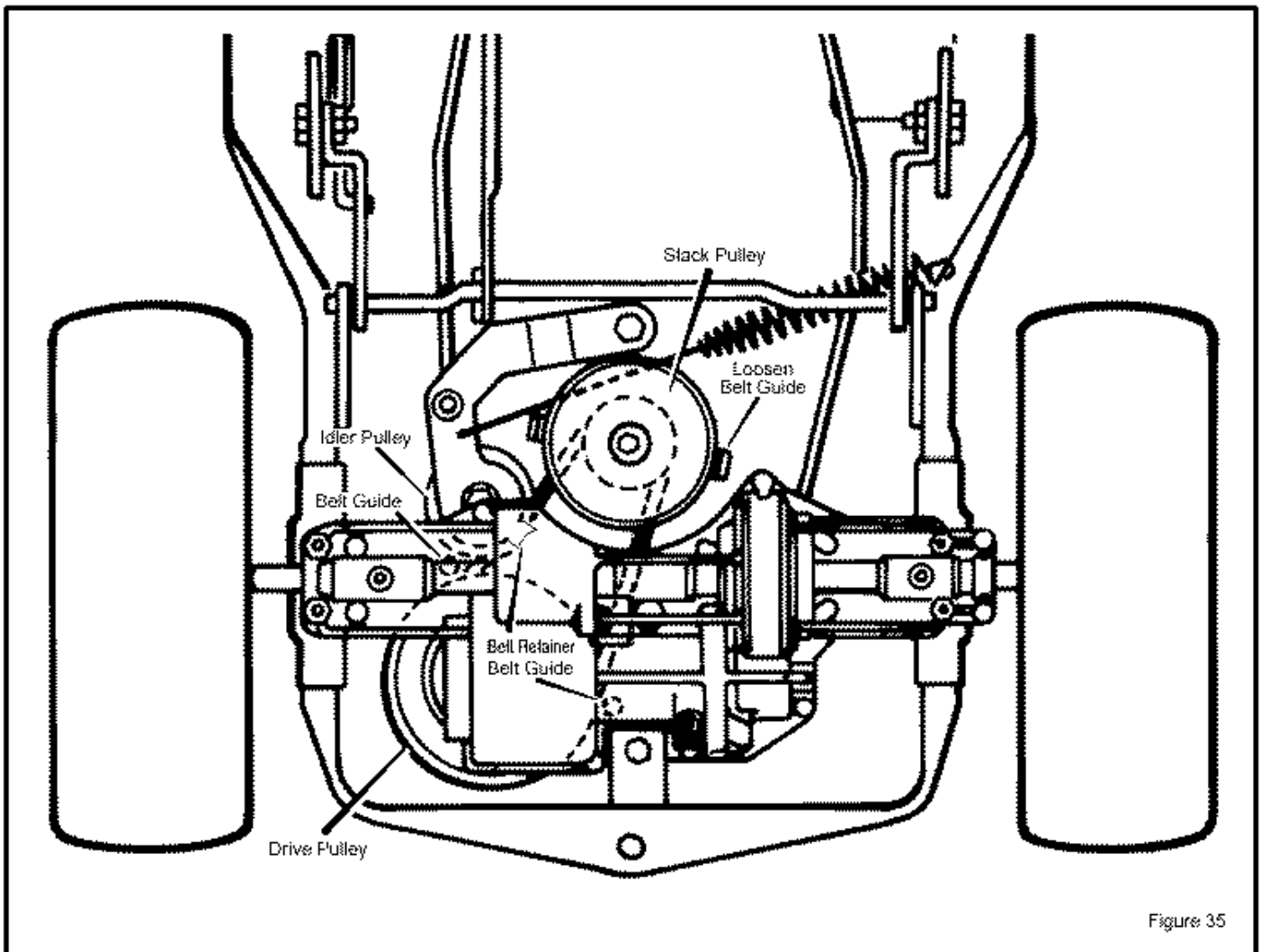
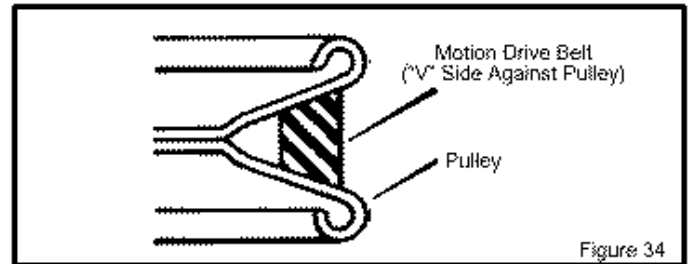

# SERVICE AND ADJUSTMENT

## HOW TO REPLACE THE MOWER DRIVE BELT

### REMOVAL

1. Move the lift lever to the lowest position.
2. Slide the **mower drive belt** between the stack pulley and the belt guide. Remove the **mower drive belt** from the stack pulley.
3. Pull the **belt retainer** away from the **idler pulley** and remove the **mower drive belt** (Figure 37).
4. Slide the **mower drive belt** between the **mandrel pulley** and the **belt guides**.

**NOTE:** Replace the mower drive belt with an original equipment belt from an authorized service center.

### INSTALLATION

1. Pull the **belt guides** away from the **mandrel pulley**. Slide the belt between the **belt guides** and the **mandrel pulley**.
2. Make sure the "V" side of the **mower drive belt** is against the **mandrel pulley** (Figure 36).

3. Pull the **belt retainer** away from the **idler pulley**. Put the **mower drive belt** around the **idler pulley**.
4. Make sure the **mower drive belt** is inside all the **belt guides**. Also make sure the **mower drive belt** is not twisted.
5. Slide the **mower drive belt** between the stack pulley and the belt guide. Install the **mower drive belt** around the the stack pulley.
6. Before you mow, check the attachment clutch. See the instructions on "How To Adjust The Attachment Clutch".

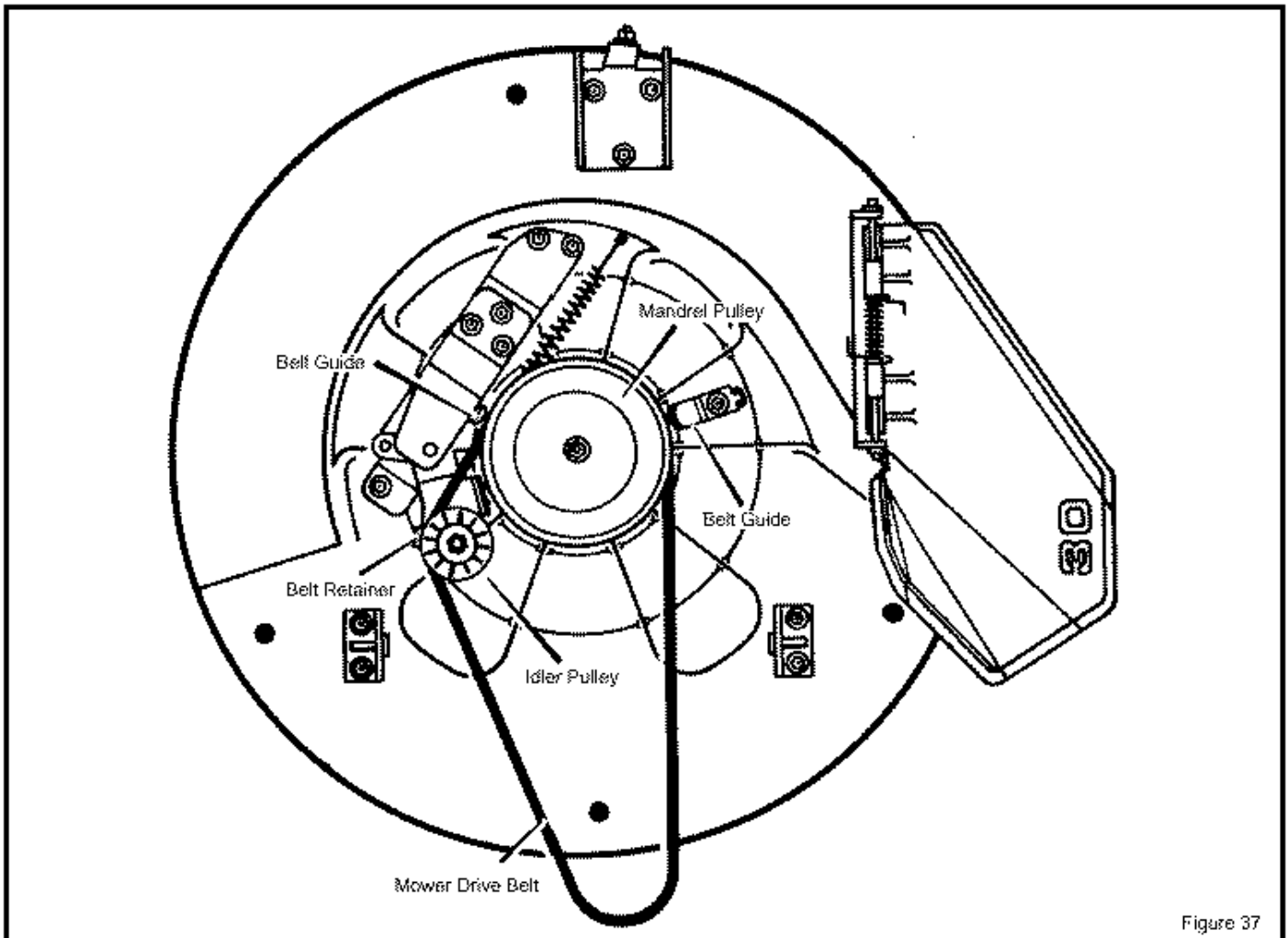
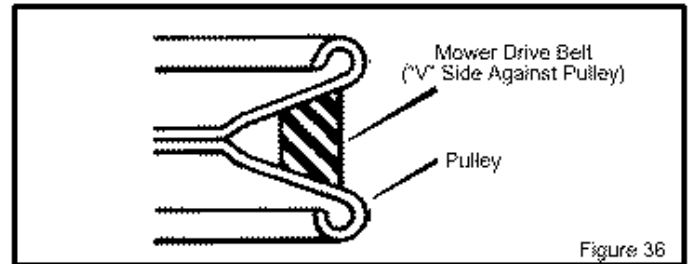

## SERVICE AND ADJUSTMENT

### HOW TO REPLACE THE FUSE

If the fuse is blown, the engine will not start. The location of the fuse is next to the battery. Remove the fuse and replace with a 15 amp. automotive fuse (Figure 38).

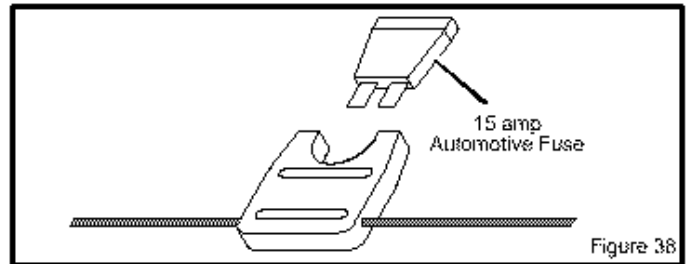

### HOW TO SET THE CUTTING HEIGHT

The cutting height is set at the factory from 1½ to 4 inches. To lower or raise the cutting height, make an adjustment to the **lifter rod** as follows.

1. Move the lift lever to the lowest position.
2. Disconnect the **lifter rod** from the **lifter arm** (Figure 39).
3. Turn the **lifter rod** clockwise to lower or counterclockwise to raise the cutting height.
4. Attach the **lifter rod** to the **lifter arm**.
5. Move the lift lever to the highest position. Make sure the pulleys or belt do not touch the bottom of the frame.

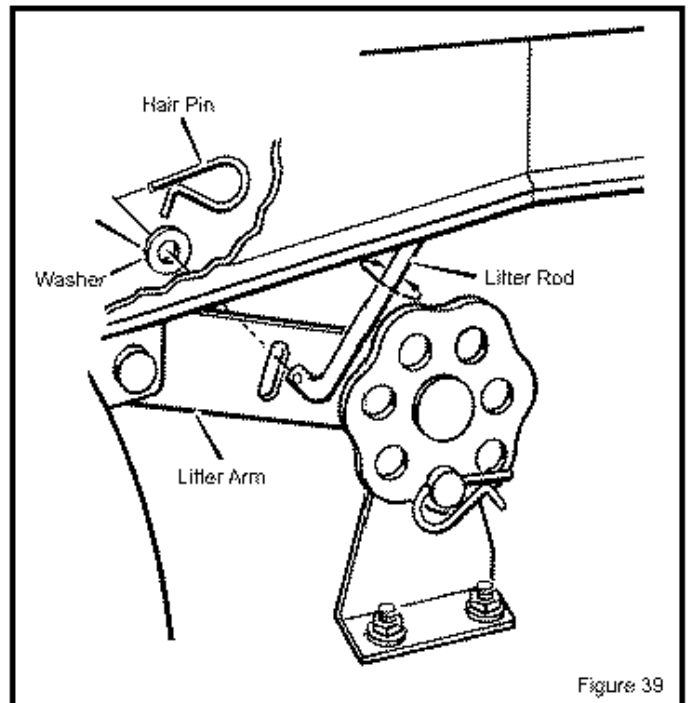

### HOW TO CLEAN THE MOWER HOUSING



**WARNING:** Before you clean the mower housing, stop the engine and disconnect the wire to the spark plug.

Grass and other debris on top of the mower housing can keep the belt from working correctly. For safety and correct operation, frequently clean the top of the mower housing. Remove grass and debris from around the pulleys and other moving parts.

1. Move the lever for the attachment clutch to the ENGAGE position.

2. Clean the top of the mower housing.
3. Move the lever for the attachment clutch to the DISENGAGE position.
4. Again clean the top of the mower housing.
5. After you cut the grass, clean the bottom of the mower housing.

### FRONT WHEEL ALIGNMENT

The alignment of the front wheels cannot be adjusted. If the steering is damaged and the alignment has changed, see your nearest authorized service center.

# SERVICE AND ADJUSTMENT

## STORAGE (over 30 days)

At the end of each year, prepare the unit for storage as follows.

### GENERAL INSPECTION

1. Inspect the belts. If the belts are damaged or worn, replace with replacement belts from the factory. See the belt replacement instructions in the Service And Adjustment section.
2. Make sure all nuts, bolts and screws are tight. Inspect moving parts for damage, breakage and wear. Replace if necessary.

### MOWER HOUSING

1. Clean the mower housing. See "How To Clean The Mower Housing".

### LUBRICATE THE UNIT

See the "Where To Lubricate" instructions in the Customer Responsibilities section.

### THE ENGINE

1. Clean the dirt and grass from the engine.
2. Change the oil. See the instructions, "How To Change The Oil".
3. Check the air screen. See the instructions, "How To Clean The Cooling System".
4. Check the spark plug. See the instructions, "How To Check The Spark Plug".

### THE FUEL SYSTEM



**WARNING:** Do not drain the gasoline inside a building or near a fire. Do not smoke because the fumes from the fuel can cause an explosion.

**CAUTION:** During storage, it is important to prevent deposits from occurring in fuel system parts like the carburetor, fuel filter, fuel line and the fuel tank. Alcohol gasoline mixtures (called gasohol or using ethanol or methanol) attract moisture causing acid deposits during storage. While the unit is in storage, the acids in the fuel can damage the fuel system. To

prevent engine problems with the fuel system, empty the fuel system before storage of 30 days or longer.

**NOTE:** Fuel stabilizer (like STA-BIL) is an acceptable alternative in reducing the formation of fuel gum in the fuel tank and the gasoline storage container. Always follow the mix ratio located on the container of stabilizer. Run the engine at least 10 minutes after adding the stabilizer to allow the stabilizer to reach the carburetor. Do not drain the fuel tank and carburetor if stabilizer is used.

If you do not use a stabilizer, do the following:

1. Start the engine.
2. Run the engine until the fuel tank and the carburetor are out of fuel and the engine stops.
3. Do not leave fuel in the fuel tank or the carburetor. The fuel can damage the function of the fuel system. Some models have a fuel drain (Figure 40). Hold a cloth under the fuel drain. Push the fuel drain until the carburetor is empty.
4. After storage, make sure you use fresh fuel.

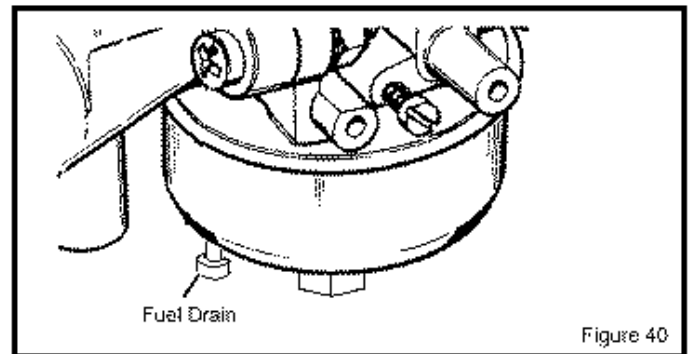

### THE BATTERY

1. Remove the battery.
2. Clean the battery terminals of any deposits.
3. Charge the battery. See the instructions on "How To Charge The Battery".
4. Store the battery in a cool, dry place.

**NOTE:** After a long time in storage, charge the battery.

# TROUBLE SHOOTING CHART

**PROBLEM: The engine will not start.**

1. Follow the steps, "How To Start The Engine" in this book.
2. Electric-Start Models: Clean the battery terminals. Tighten the cables.
3. Drain the fuel tank. Clean the fuel line. Replace the fuel filter.
4. Remove the spark plug(s). Move the throttle to the SLOW position. Turn the ignition key to the ON position. Try to start the engine several times. Install the spark plug.
5. Replace the spark plug.
6. Adjust the carburetor.

**PROBLEM: The engine will not turn over.**

1. Follow the steps, "How To Start The Engine" in this book.
2. Electric-Start Models: Check the level of the acid in the battery. If needed, add water. Charge the battery.
3. Replace the fuse.
4. Check the wiring harness for damage or a loose connection. Repair the damaged wire.
5. Electric-Start Models: replace the solenoid. Recoil-Start Models: replace the module.

**PROBLEM: The engine is difficult to start.**

1. Adjust the carburetor.
2. Replace the spark plug.
3. Replace the fuel filter.

**PROBLEM: The engine does not run smooth or has a loss of power.**

1. Check the oil.
2. Clean the air filter.
3. Clean the air screen.
4. Replace the spark plug.
5. The engine is working too hard. Use a lower gear.
6. Adjust the carburetor.
7. Replace the fuel filter.

**PROBLEM: The engine does not run smooth at fast speed.**

1. Replace the spark plug.
2. Adjust the throttle control.
3. Clean the air filter.
4. Replace the fuel filter.

**PROBLEM: The engine stops when the blades are engaged.**

1. To activate the seat sensor, always sit in the middle of the seat.
2. Check the wiring harness for damage or a loose connection. Repair the damaged wire.

**PROBLEM: On slopes, the engine stops.**

1. Mow up and down slopes. Never mow across a slope.
2. To activate the seat sensor, always sit in the middle of the seat.

**PROBLEM: The engine will not idle.**

1. Replace the spark plug.
2. Clean the air filter.
3. Adjust the carburetor.
4. Adjust the throttle control.
5. Drain the fuel tank. Clean the fuel line. Replace the fuel filter.

**PROBLEM: A hot engine causes a decrease in power.**

1. Clean the air screen.
2. Check the oil.
3. Adjust the carburetor.
4. Replace the fuel filter.

**PROBLEM: Excessive vibration.**

1. Replace the blade.
2. Check for loose engine bolts.
3. Decrease the air pressure in the tires.
4. Adjust the carburetor.
5. Check for a damaged belt or damaged pulley. Replace the damaged parts.

**PROBLEM: The grass does not discharge correctly.**

1. Stop the engine. Clean the mower housing.
2. Raise the height of cut.
3. Replace or sharpen the blade(s).
4. Move the shift lever to a slower speed.
5. Move the throttle control to the FAST position.
6. Replace the spring for the blade idler.

**PROBLEM: The mower housing does not cut level.**

1. Check the air pressure in the tires.
2. Adjust the level of the mower housing.
3. Check the front axle. If the front axle does not freely pivot, loosen the axle bolt(s).

**PROBLEM: The mower blades will not rotate.**

1. Check the mower drive belt. Make sure the belt is installed correctly.
2. Replace the mower drive belt.

**PROBLEM: The unit will not move when the clutch is engaged.**

1. Check the motion drive belt. Make sure the belt is installed correctly.
2. Adjust the clutch.
3. Replace the motion drive belt.

**PROBLEM: The unit moves slower or stops when the clutch is engaged.**

1. Adjust the clutch.
2. Replace the motion drive belt.

**PROBLEM: When the clutch/brake pedal is released, belt noise can be heard.**

1. Temporary belt noise does not change the operation of the unit. If belt noise is continuous, check the routing of the belt. Make sure the belt is inside all belt guides.
2. If the noise is continuous, adjust the clutch.

**PROBLEM: The rear wheels spin over uneven terrain.**

1. Check the front axle. If the front axle does not freely pivot, loosen the axle bolt(s).

**PROBLEM: The transaxle is difficult to shift between gears with the engine running and the clutch depressed.**

1. Check the clutch adjustment to make sure the belt stops when the clutch pedal is depressed with the transaxle in (N) neutral.
2. Check the belt guides around the transaxle drive pulley. Make sure the belt guides do not touch the pulley.

# SLOPE GUIDE

SIGHT AND HOLD THIS GUIDE LEVEL WITH A VERTICAL TREE, A CORNER OF A STRUCTURE, A POWER LINE POLE, OR A FENCE.

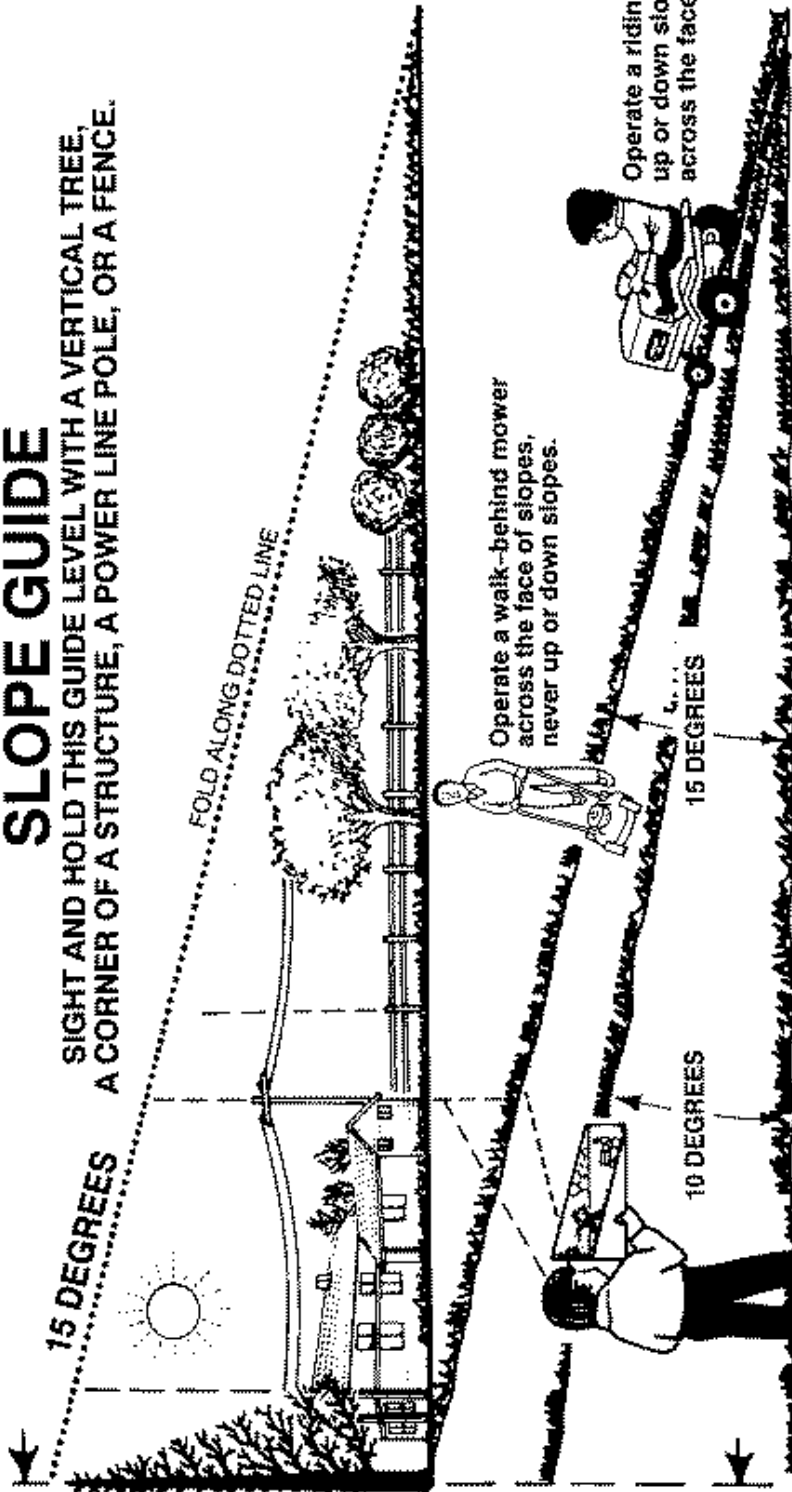

Operate a riding mower up or down slopes, never across the face of slopes.

Operate a walk-behind mower across the face of slopes, never up or down slopes.

On a riding mower to determine if a slope is safe to mow: (1) disengage the blade(s), (2) put the unit in reverse, and (3) try to back straight up the slope. If you can back up the slope, it is generally safe to mow. However, if you do not feel safe, or if you are not completely sure, use this guide and do not mow a slope that is greater than 15 degrees. If the riding mower is used with a pull-behind or rear mounted attachment, do not operate the unit on a slope that is greater than 10 degrees.

A 15 degree slope is a hill that increases in height at approximately 2.5 feet in 10 feet.  
 A 10 degree slope is a hill that increases in height at approximately 1.7 feet in 10 feet.



Use extreme care at all times, and avoid sudden turns or maneuvers. Follow other instructions in this manual for safety in mowing on slopes. Operate a riding mower up or down slopes, never across the face of slopes. Operate a walk-behind mower across the face of slopes, never up or down slopes. Use extra care when operating on or near slopes and obstructions.

\*\*\*\*\* CUT HERE TO USE SLOPE GUIDE \*\*\*\*\*

# INDEX

## A

- Adjustments
  - Attachment Clutch, 20
  - Clutch, 21
  - Drive Brake, 21
  - Mower Housing
    - Cutting Height, 31
    - Level, 28
- Air Screen, 24
- Attachment Clutch
  - Adjust, 20
  - Location, 11
  - Operation, 12
- Attachments, 6

## B

- Battery
  - Charge, 22
  - Check, 8
  - Check Acid Level, 22
  - Clean, 22
  - Emergency Start, 15
  - Install, 8
  - Removal, 8, 22

## Belt

- Motion Drive
  - Adjust, 21
  - Replace, 29
  - Routing, 9
- Mower Drive
  - Adjust, 20
  - Replace, 30
  - Routing, 9

## Blade

- Inspect, 19
- Remove And Install, 19
- Sharpen, 19

## C

- Clutch
  - Adjust, 21
  - Check, 21
- Clutch / Brake Pedal, Location, 11
- Customer Responsibilities
  - Attachment Clutch, 20
  - Battery
    - Charge, 22
    - Check Acid, 22
    - Clean, 22
  - Blade, 19
  - Clutch, 21
  - Drive Brake, 21
  - Filter, Air, 25
  - Lubrication, 23
  - Maintenance Chart, 18
  - Muffler, 24
  - Spark Plug, 26
- Cutting Height
  - Adjust, 28, 31
  - Change, 13

F-000614J

## D

- Drive Brake
  - Adjust, 21
  - Check, 21

## E

- Engine
  - Cooling System, 24
  - Fuel, 15
  - Lubrication, 24
  - Muffler, 24
  - Oil, 15, 24
  - Spark Arrester, 24
  - Starting, 15
  - Throttle Control, 12

## F

- Filter, Air, 25
- Fuel, Type, 15
- Fuse, 31

## I

- Ignition Switch, Location, 11

## L

- Lift Lever
  - Location, 11
  - Operation, 13
- Lubrication
  - Engine, 24
  - Mower, 23

## M

- Maintenance Chart, 18
- Motion Drive Belt
  - Adjust, 21
  - Replace, 29
- Mower Drive Belt
  - Adjust, 20
  - Replace, 30
- Mower Housing
  - Clean, 31
  - Cutting Height, 13, 31
  - Install, 27
  - Level Adjustment, 28
  - Operation, 14
  - Remove, 27
- Muffler, 24
  - Spark Arrester, 24
- Mulcher
  - Install, 16
  - Operation, 17
  - Remove, 16

## O

- Oil
  - Change, 24
  - Check, 15, 24

35

- Type, 15
- Operation
  - Attachment Clutch, 11, 12
  - Clutch / Brake Pedal, 11
  - Emergency Start, 15
  - Ignition Switch, 11
  - Lift Lever, 11, 13
  - Location Of Controls, 11
  - Mower Housing, 14
  - Mowing And Bagging, 17
  - Mulching, 17
  - Operate On Hills, 14
  - Parking Brake, 11, 13
  - Shift Lever, 11, 12
  - Start The Engine, 15
  - Stop The Unit, 13
  - Throttle Control, 11, 12
  - Transport, 13

## P

- Parking Brake
  - Location, 11
  - Operation, 13

## S

- Safety Rules, American National Standard Institute, 4-6
- Seat, Install, 10
- Service And Adjustment
  - Belt
    - Motion Drive, 29
    - Mower Drive, 30
  - Fuse, 31
  - Mower Housing
    - Clean, 31
    - Cutting Height, 31
    - Install, 27
    - Level, 28
    - Remove, 27
    - Storage, 32
  - Shift Lever
    - Location, 11
    - Operation, 12
  - Side Panel, 22
  - Slope Guide, 34
  - Spark Arrester, 24
  - Spark Plug, 25
  - Steering Wheel, 9
  - Storage, 32

## T

- Throttle Control
  - Location, 11
  - Operation, 12
- Tire Pressure, 9, 18, 28
- Trouble Shooting Chart, 33

## W

- Wheel Alignment, 31

# MODEL 536.270212

# REPAIR PARTS BODY CHASSIS

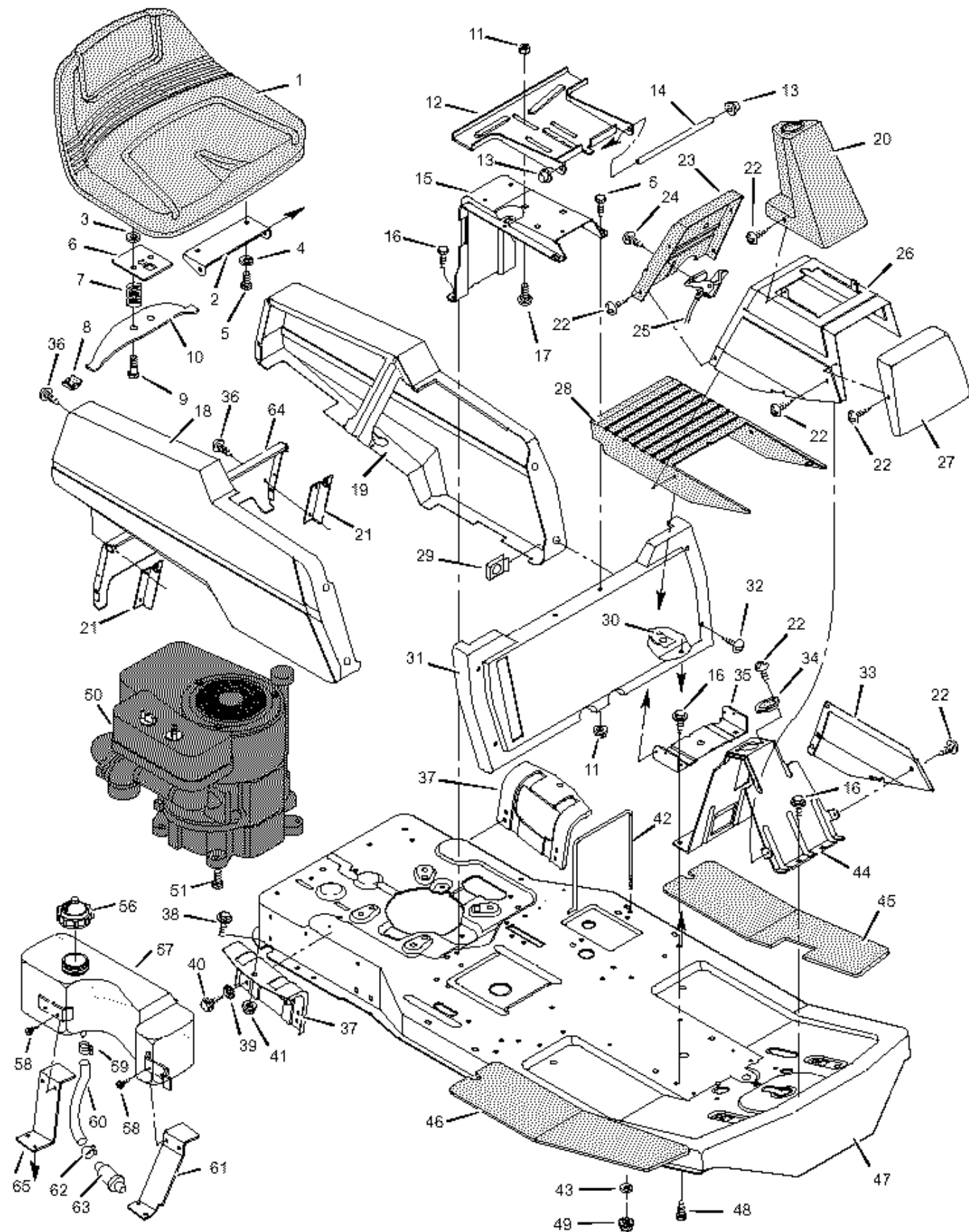

F-000614J

36

# MODEL 536.270212

# REPAIR PARTS BODY CHASSIS

Key No.	Description	Part No.	Mfg. No.	Key No.	Description	Part No.	Mfg. No.
1	Seat	92387		35	Bracket, Cover Mounting	56233E700	
2	Hinge, Seat	56516E700		36	Screw	26x250	
3	Retainer	28x64		37	Support, Body	56122E700	
4	Lockwasher	STD551131	18x16	38	Bolt, Shoulder	9x29	
5	Bolt, Hex	STD523106	1x45	39	Lockwasher	STD551231	19x6
6	Plate, Seat Switch	91963Z		40	Screw	26x49	
7	Spring, Compression	164x26		41	Locknut, Flange	STD541437	15x84
8	Glide, Seat Spring	91822		42	Clamp Assembly, Battery	54800Z	
9	Bolt, Shoulder	9x38		43	Washer	STD551025	17x38Z
10	Spring, Seat	91964		44	Support, Steering Column	56240E700	
11	Locknut, Flange	STD541431	15x88	45	Mat, Left	54795	
12	Bracket, Seat Pivot	56518E700		46	Mat, Right	54796	
13	Cap, Push On	28x23		47	Frame	56612E549	
14	Rod, Seat Hinge	56537Z		48	Screw	6x74	
15	Support, Seat	56519E700		49	Locknut	STD541425	15x66
16	Screw	26x249		50	Engine, Craftsman Model 143.981300	*	
17	Bolt, Carriage	STD533107	2x53	51	Bolt, Engine Mount	25x7	
18	Panel, Right Side	54764E549		56	Cap, Fuel	92317	
19	Panel, Left Side	54763E549		57	Tank, Fuel	55805	
20	Cover, Steering Column	94353		58	Screw, Hex	26x213	
21	Bracket, Panel	54747E549		59	Clamp, Hose	23717	
22	Screw, Tapping	26x270		60	Line, Fuel	91022	
23	Panel, Control	94351		61	Bracket, Remote Tank (Front)	94940	
24	Screw	STD610803	26x201	62	Clamp, Gas Line	91174	
25	Throttle Control	56247		63	Filter, Fuel	56002	
26	Console	56405E549		64	Panel, Rear	54782E549	
27	Cap, Front Console	56407E549		65	Bracket, Remote Tank (Rear)	94941	
28	Cover, Lower Console	94352		—	Owner's Manual (English)	F-000614J	
29	Retainer	28x52		—	Owner's Manual (Spanish)	F-000614JSP	
30	J-Nut	28x18		—	Decal, Right Panel	48x210	
31	Panel, Front	56235E549		—	Decal, Left Panel	48x211	
32	Screw, Southco	91330		—	Decal, Front Console	48x209	
33	Panel, Left Access	56406E549					
34	Bearing, Steering Post	56022					

\* NOTE: See pages 50 – 55 for replacement parts.  
F-000614J

# MODEL 536.270212

# REPAIR PARTS MOTION DRIVE

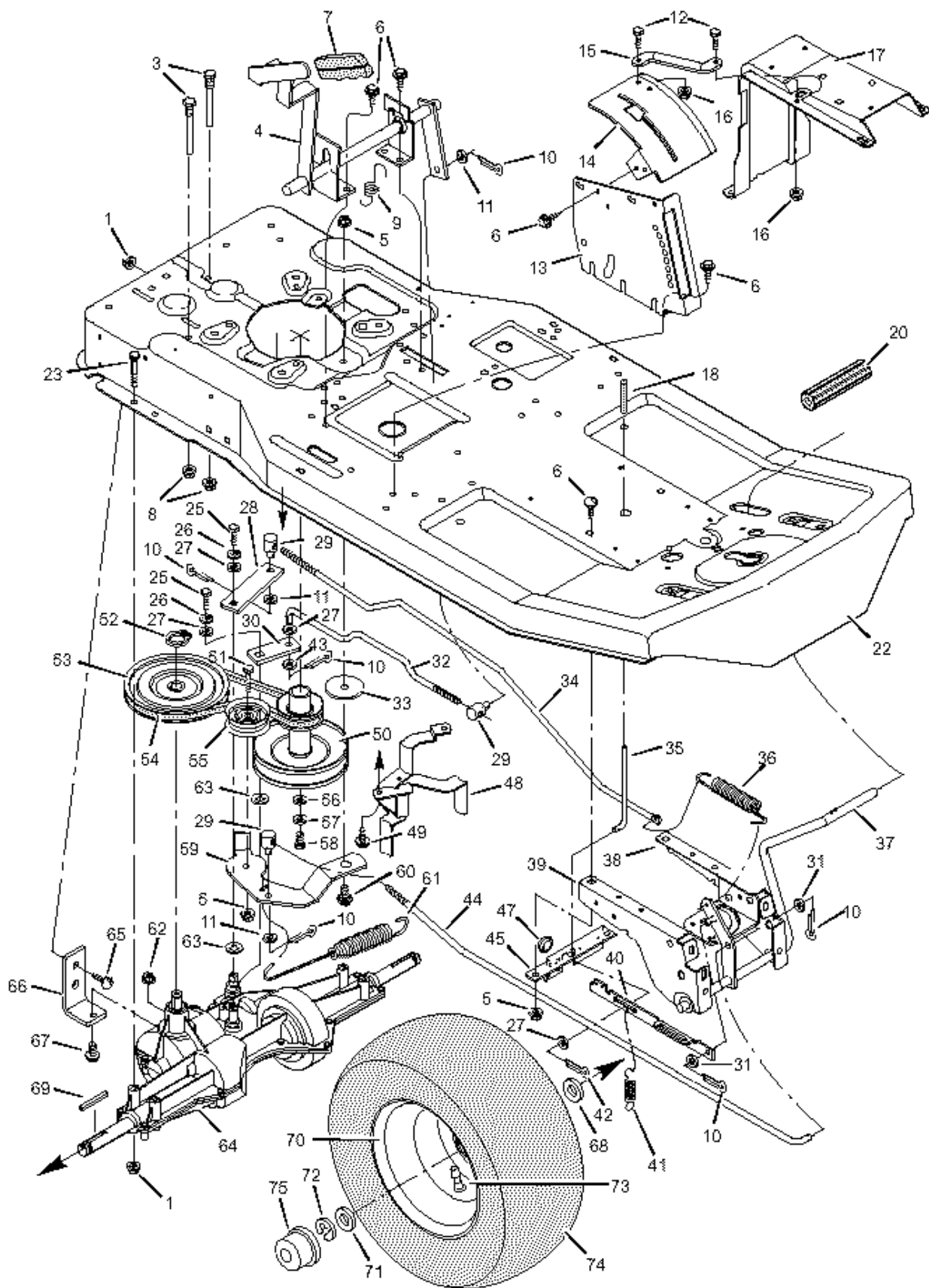

# MODEL 536.270212

# REPAIR PARTS MOTION DRIVE

Key No.	Description	Part No.	Mfg. No.	Key No.	Description	Part No.	Mfg. No.
1	Locknut, Flange	STD541431	15x88	40	Link, Parking Brake	56565Z	
3	Guide, Belt	93349		41	Spring, Extension	165x107	
4	Shifter Assembly	56610E701		42	Pin, Cotter	STD560907	30x50
5	Locknut, Flange	STD541437	15x84	43	Washer	STD551031	17x46Z
6	Screw	26x267		44	Rod, Clutch	56531Z	
7	Grip, Shift Lever	91573		45	Stop, Parking Brake	56227E701	
8	Hex Nut	15x79		47	Grommet	56623	
9	Spring, Extension	165x100		48	Guide, Belt	56215Z	
10	Pin, Cotter	STD560907	30x20	49	Screw	26x49	
11	Washer	STD551037	17x53Z	50	Pulley Assembly, Stack	92504Z	
12	Bolt, Hex	STD522506	1x38	51	Bolt, Hex	STD523715	1x111
13	Plate, Index	56595E701		52	Ring, Retainer	STD582062	11x7
14	Gate, Shift	56606E701		53	Pulley, Drive	56562	
15	Brace, Shift Gate	56529E701		54	Belt, Motion Drive	37x65	
16	Locknut, Flange	STD541425	15x89	55	Pulley, Idler	56526	
17	Support, Seat	56519E549		56	Washer	17x170	
18	Grip, Parking Brake	55873		57	Lockwasher	STD551243	19x35
20	Pedal	55825		58	Bolt, Hex	1x140	
22	Frame Assembly	56612E549		59	Bracket, Idler	1001034E701	
23	Bolt, Hex	1x124		60	Bolt, Shoulder	9x42	
25	Bolt, Hex	1x145		61	Spring, Extension	165x81	
26	Lockwasher	STD551125	18x32	62	Locknut, Hex	STD541431	15x43
27	Washer	17x36Z		63	Washer	17x148	
28	Yoke, Brake	56500Z		64	Transaxle, Dana Model 4450-1	†	
29	Nut, Adjusting	21920		65	Bolt, Carriage	STD533107	2x53
30	Yoke, Shift	56505Z		66	Bracket, Transaxle	56503E701	
31	Washer	STD551031	17x47Z	67	Bolt, Hex	1x139	
32	Rod, Shift	56591Z		68	Washer	17x160	
33	Washer, Hardened	17x174HT		69	Key, Square	56534	
34	Rod, Brake	56530Z		70	Wheel & Tire Assembly	92308-601	
35	Rod, Parking Brake	56410Z		71	Washer	17x195	
36	Spring, Extension	165x85		72	E-Ring	STD581075	11x3
37	Lever, Pedal	56511E701		73	Valve Stem **	24373	
38	Plate, Left Suspension	56224E701		74	Tire Only **	24393	
39	Plate, Right Suspension	56023E701		75	Hub Cap, Optional	94618	

\* See pages 48 - 49 for replacement parts.

\*\* Included with Key No. 70.



# MODEL 536.270212

# REPAIR PARTS STEERING

Key No.	Description	Part No.	Mfg. No.
1	Steering Wheel	54783	
2	Bellows, Steering Post	54789	
3	Bolt, Hex	STD523115	1x102
4	Locknut, Flange	STD541431	15x88
5	Post, Steering	56417C	
6	Nut, Hex	STD541531	15x90
9	Bolt, Carriage	STD533107	2x64
10	Screw	26x249	
11	Plate, Left Suspension	56224E701	
13	Plate, Right Suspension	56023E701	
14	Bolt, Hex	STD623725	1x69
15	Support, Front Axle	56231E701	
16	Pin, Cotter	STD561220	30x49
17	Bearing, Spindle	55003	
18	Adapter, Steering Post	56416	
19	Gear, Pinion	56418	
20	Axle Assembly, Front	56223E549	
21	Hanger Assembly, Front Axle	56230E701	
22	Bearing	55168	
23	Sector Assembly	56236E701	
24	Rod, Drag Link	56625E701	
25	Ball Joint, Steering	21031	
26	Nut, Hex	15x61	
27	Locknut, Flange	STD541537	15x87
28	Washer	17x87	
30	Washer	STD551037	17x53
32	Pin, Cotter	STD560907	30x20
34	Spindle Assembly, Left	55039E549	
35	Rod, Tie	55026E701	
36	Spindle Assembly, Right	55038E549	
37	Bearing, Wheel *	56105	
38	Tire Only *	55700	
39	Valve Stem *	24373	
40	Wheel & Tire Assembly	92303-601	
41	Washer	17x197	
42	Hub Cap	94618	

\* included with Key No. 40.  
F--000614J

# MODEL 536.270212

# REPAIR PARTS MOWER HOUSING SUSPENSION

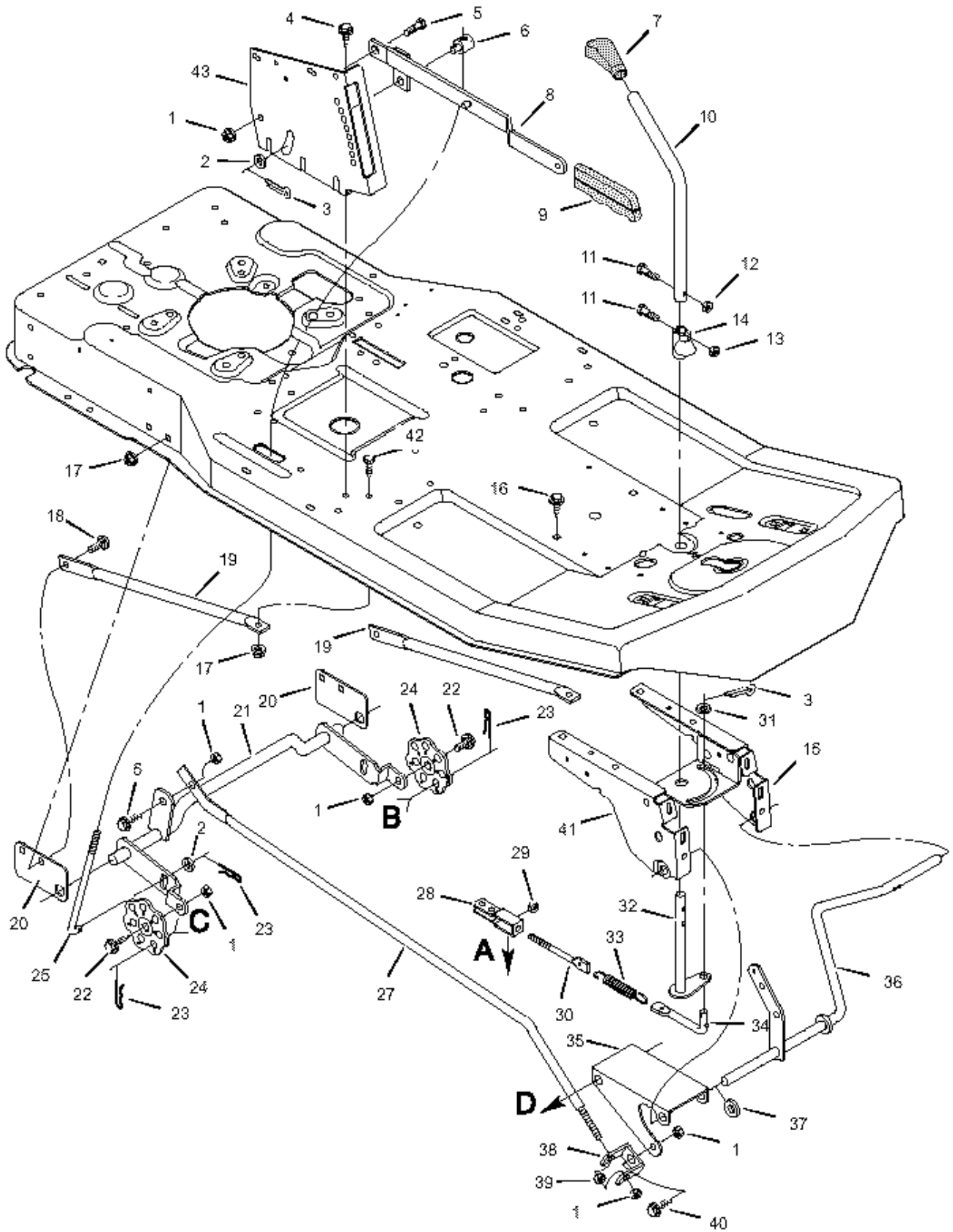

**MODEL 536.270212****REPAIR PARTS  
MOWER HOUSING SUSPENSION**

<b>Key No.</b>	<b>Description</b>	<b>Part No.</b>	<b>Mfg. No.</b>
1	Locknut, Flange	STD541437	15x84
2	Washer	STD551037	17x53
3	Pin, Cotter	STD560907	30x20
4	Screw	26x249	
5	Bolt, Shoulder	9x9Z	
6	Nut, Adjusting	21920	
7	Grip, Blade Control	92698	
8	Lever Assembly, Lift	56031E701	
9	Grip, Lift Lever	56160	
10	Attachment, Clutch	55928Z	
11	Bolt, Hex	STD522510	1x76
12	Locknut	STD541425	15x66
13	Locknut, Flange	STD541425	15x89
14	Cam, Blade Control	55853	
15	Plate, Left Suspension	56224E701	
16	Screw	26x249	
17	Locknut, Flange	STD541431	15x88
18	Bolt, Carriage	STD533107	2x64
19	Strut, Frame	55326E701	
20	Plate, Mounting	55270E701	
21	Rod Assembly, Rear Suspension	55346E701	
22	Bolt, Shoulder	9x4	
23	Pin, Hair	31x4	
24	Plate, Adjusting	55344E701	
25	Rod, Lifter	24839E701	
27	Rod, Suspension	55957E701	
28	Clevis	24471Z	
29	Nut, Hex	15x2	
30	Link, Blade Drive	55271Z	
31	Washer	17x48	
32	Rod and Arm Assembly	55930E701	
33	Spring, Extension	165x67	
34	Link, Front Deck	55179E701	
35	Bracket, Front Suspension	55139E701	
36	Lever, Pedal	56511E701	
37	Washer	17x122	
38	Clevis	55298	
39	Locknut, Hex	15x73	
40	Bolt, Shoulder	9x17	
41	Plate, Right Suspension	56023E701	
42	Bolt, Hex	STD523106	1x45
43	Plate, Index	56595E701	



# MODEL 536.270212

# REPAIR PARTS MOWER HOUSING

Key No.	Description	Part No.	Mfg. No.	Key No.	Description	Part No.	Mfg. No.
1	Belt, Mower Drive	37x57		27	Spring, Torsional	166x4	
2	Pulley, Splined	91951		28	Push On Cap	28x23	
3	Lockwasher	18x33		29	Rod	21197Z	
4	Locknut, Hex	15x100		30	Hinge, Chute Deflector	56213E701	
5	Nut, Hex	STD541450	15x41	31	Washer	17x91 Z	
6	Pulley, Idler	690410		32	Spring, Extension	165x68	
7	Bracket, Upper Idler	55921E701		33	Spacer	690369	
8	Spacer	55895Z		34	Bracket, Front	55916E701	
9	Assembly, Blade Idler	55979E701		35	Screw	26x216	
10	Locknut, Flange	STD541431	15x88	36	Bolt, Hex	STD523117	1x75
11	Pin, Clevis	29x99		37	Deflector, Chute	55971	
12	Clevis	24471Z		38	Mandrel	91921	
13	Bolt, Hex	STD523106	1x45	39	Adapter, Blade	92466	
14	Pin, Hair	STD624003	31x6	40	Washer, Belleville	17x166	
15	Guide, Belt	55977E701		41	Washer, Hardened	17x165	
16	Bracket, Lower Idler	55920E701		42	Nut, Hex	15x100	
17	Bolt, Carriage	STD533107	2x53Z	43	Pin, Pull	90828Z	
18	Nut, Flange	STD541031	15x79	44	Washer	STD551050	17x67Z
19	Guide, Belt	55894E701		45	Pin, Hair	STD624005	31x4
20	Spacer	91925		46	Housing, Blade	56059E701	
21	Bolt, Hex	STD525015	1x127	47	Blade, Mulcher	56217E701	
22	Housing, Mandrel	55962E701		1-47	Mower Housing, Complete	403343	
23	Guide, Belt	55956Z		48	Plate, Mulcher	56211E701	
24	Bracket, Hanger	55974E701		49	Bolt, Carriage	STD533107	2x64
25	Spring, Compression	164x1		50	Wingnut	14x86	
26	Nut, Hex	STD541431	15x43Z	51	Blade, Standard	56212E701	

# MODEL 536.270212

# REPAIR PARTS ELECTRICAL SYSTEM

POS.	FUNCTION	CIRCUIT (MAKE)
1	OFF	M+G
2	RUN	NONE
3	START	B+S

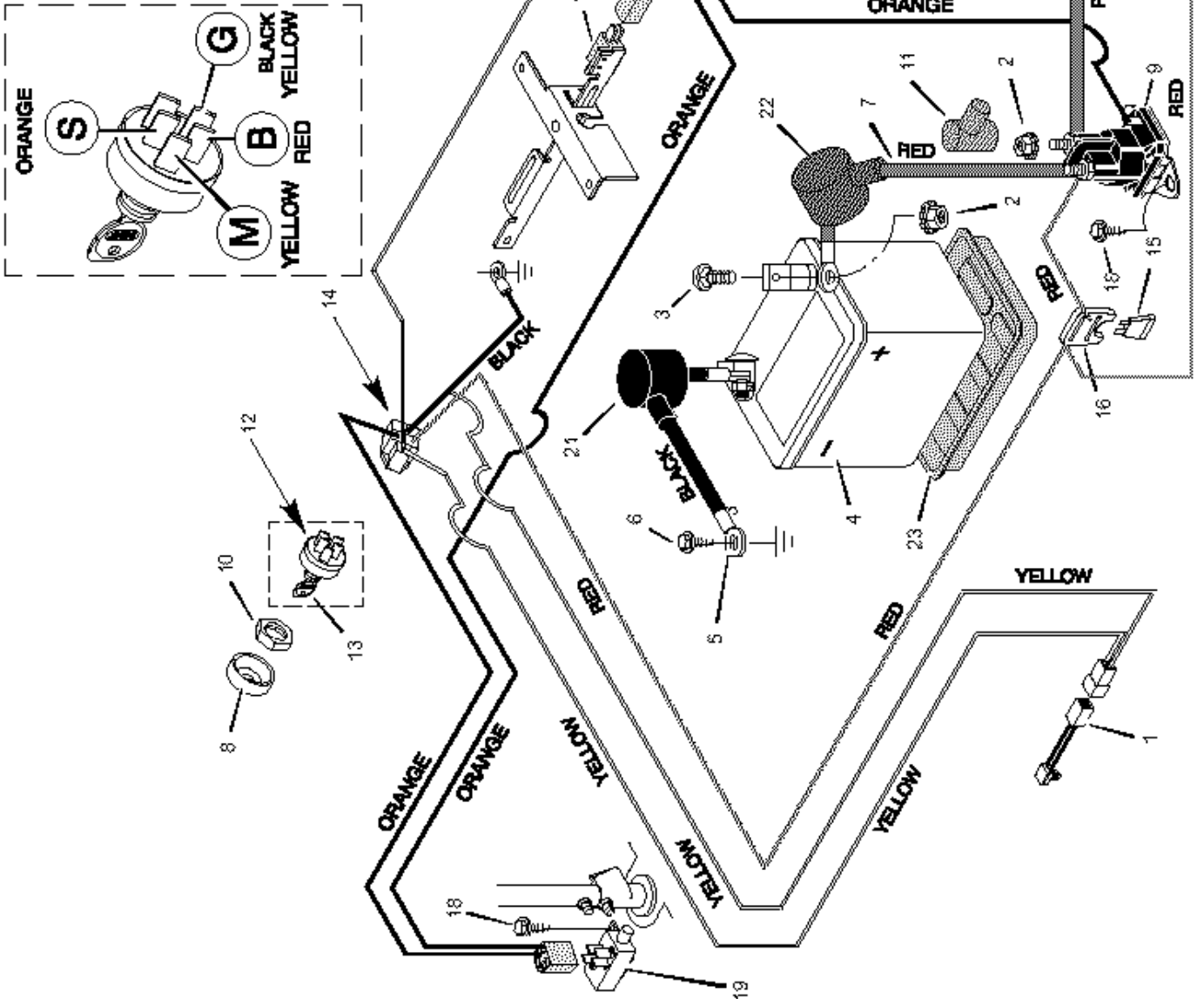

# MODEL 536.270212

# REPAIR PARTS ELECTRICAL SYSTEM

Key No.	Description	Part No.	Mfg. No.
1	Switch, Seat Sensor	91031	
2	Nut, Keys	STD541425	f5x66
3	Bolt, Carriage	STD533125	2x82
4	Battery (Type U1-L5)	92196	
5	Cable, Battery Ground (Black)	24x3	
6	Screw	26x249	
7	Cable, Positive Battery (Red)	24x24	
8	Cap, Ignition Switch	91488	
9	Solenoid	94613	
10	Nut, Ignition Switch	91489	
11	Cover, Solenoid	24196	
12	Switch, Ignition	21064	
13	Key, Ignition	91275	
14	Harness, Wire	250x84	
15	Fuse	54212	
16	Holder, Fuse	407078	
17	Switch, Attachment Clutch	91032	
18	Screw	26x233	
19	Switch, Limit	24273	
21	Cover, Black Terminal	690605	
22	Cover, Red Terminal	690604	
23	Tray, Battery	91896	

# MODEL 536.270212

# REPAIR PARTS 5 SPEED TRANSAXLE DANA MODEL: 4450-1

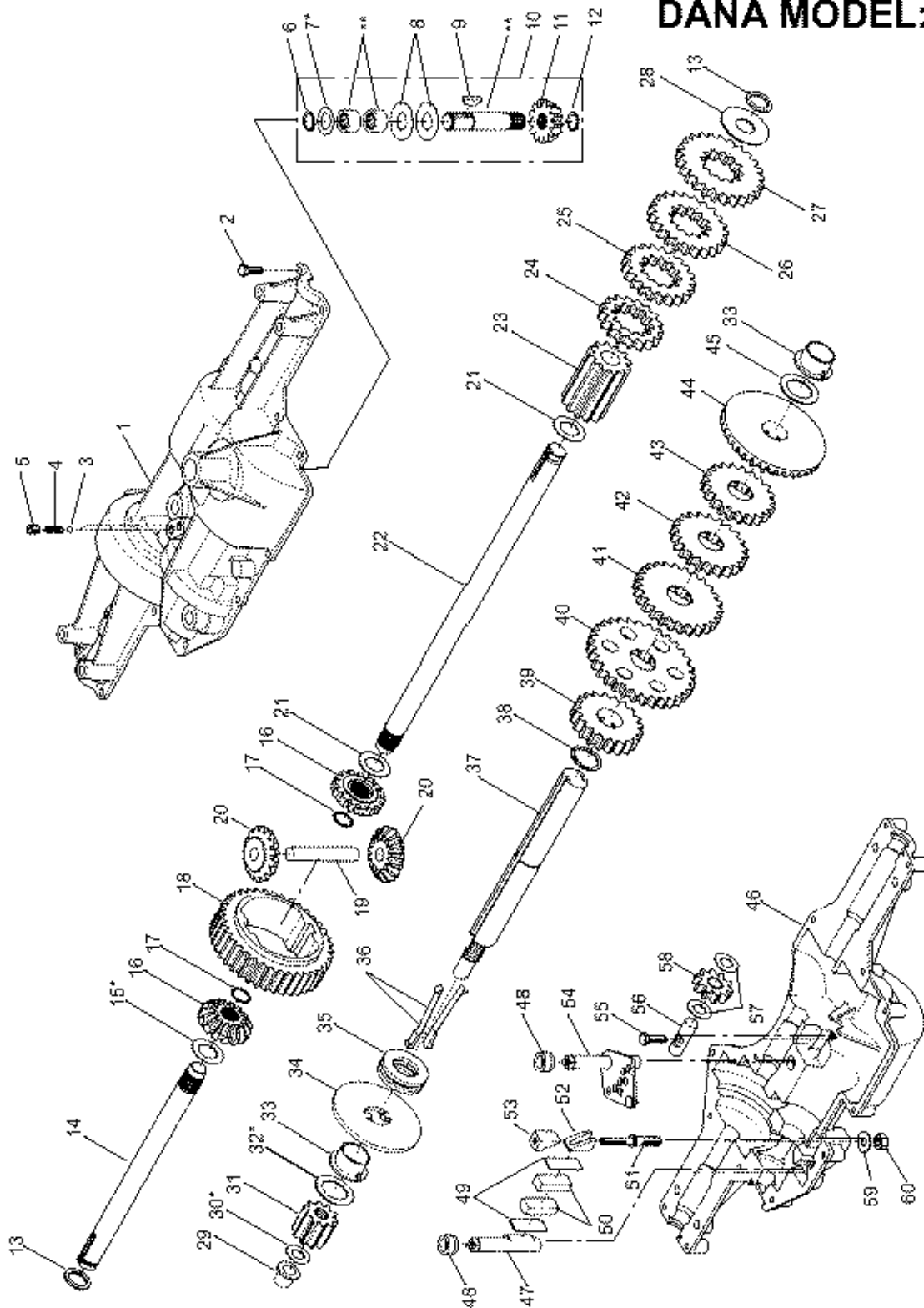

# MODEL 536.270212

# REPAIR PARTS 5 SPEED TRANSAXLE DANA MODEL: 4450-1

Key No.	Description	Part No.	Key No.	Description	Part No.
1	Housing, Upper	3975	30	Washer, Plain .505 x .942 x .010	*3886
2	Screw, Tapping 1/4-20 x .734 (14 req.)	1919	30	Washer, Plain .505 x .942 x .015	*3887
3	Bail, Detent (2 req.)	1151	30	Washer, Plain .505 x .942 x .020	*3888
4	Spring, Detent (2 req.)	3626	30	Washer, Plain .505 x .942 x .026	*3889
5	Screw, Set (2 req.)	3623	30	Washer, Plain .505 x .942 x .030	*3121
6	Ring, Retainer	1099	30	Washer, Plain .505 x .942 x .040	*3890
7	Washer, Plain .632 x 1.00 x .031	*1082	30	Washer, Plain .505 x .942 x .060	*3892
7	Washer, Plain .632 x 1.00 x .036	*1424	31	Gear, Spur -10T	3933
7	Washer, Plain .632 x 1.00 x .041	*1068	32	Washer, Plain 1.01 x 1.50 x .061	*3961
7	Washer, Plain .632 x 1.00 x .046	*1425	32	Washer, Plain 1.01 x 1.50 x .075	*3993
7	Washer, Plain .632 x 1.00 x .050	*1358	32	Washer, Plain 1.01 x 1.50 x .090	*3994
7	Washer, Plain .632 x 1.00 x .060	*1145	33	Bearing, Flange (2 req.)	3937
7	Washer, Plain .632 x 1.00 x .082	*1319	34	Disc, Brake	3990
8	Washer, Plain .632 x 1.38 x .046 (2 req.)	3876	35	Collar, Clutch	3959
9	Key, Woodruff, #9	1374	36	Key, Clutch (2 req.)	3996
10	Assembly Kit, Input Shaft	4513	37	Shaft, Drive	3997
11	Pinion, Bevel 13T	3936	38	Ring, Retainer	3958
12	Ring, Retainer	3956	39	Gear, Spur -20T	3949
13	Seal, Felt (2 req.)	3191	40	Gear, Spur -32T	3948
14	Axle, L.H.	3939	41	Gear, Spur -26T	3947
15	Washer, Plain .758 x 1.25 x .020	*3408	42	Gear, Spur -22T	3946
15	Washer, Plain .758 x 1.25 x .025	*3732	43	Gear, Spur -21T	3945
15	Washer, Plain .758 x 1.25 x .031	*3184	44	Gear, Bevel, Comb. 39 & 18T	3938
15	Washer, Plain .758 x 1.25 x .035	*3733	45	Washer, Plain 1.01 x 1.50 x .061	3961
15	Washer, Plain .758 x 1.25 x .040	*3198	46	Housing, Lower	3974
15	Washer, Plain .758 x 1.25 x .045	*3734	47	Shaft, Brake	5003
15	Washer, Plain .758 x 1.25 x .050	*3735	48	V-Ring (2 req.)	3789
16	Gear, Miter -15T (2 req.)	3780	49	Spacer (2 req.)	5036
17	Ring, Retainer (2 req.)	3656	50	Puck, Friction (2 req.)	5034
18	Gear, Spur -39T	3934	51	Stud, Adjustment -Brake	3998
19	Shaft, Cross	3919	52	Cam, Adjustment -Slotted	5000
20	Gear, Miter -15T (2 req.)	3781	53	Cam, Adjustment -Brake	3999
21	Washer, Plain .758 x 1.25 x .062 (2 req.)	3180	54	Assembly, Shifter	4449
22	Axle, R.H.	3940	55	Screw, Tap 1/4 -18 x .875	3396
23	Gear, Spur -12T	3953	56	Shaft, Idler	3987
24	Gear, Spur -17T	3951	57	Washer, Plain .505 x .942 x .015	3887
25	Gear, Spur -21T	3941	58	Assembly, Gear Spur -10T	4492
26	Gear, Spur -23T	3942	59	Washer, Plain .325 x .750 x .059	3906
27	Gear, Spur -25T	3943	60	Locknut 5/16 -24	3847
28	Washer, Plain .758 x 1.88 x .062	3955	61	Grease	4300
29	Bearing, Flange	3991			

\* Use in various combinations to maintain proper clearances.

\*\* Order Key Number 10.

F-000614J



# MODEL 536.270212

# ENGINE 143.981300 REPAIR PARTS

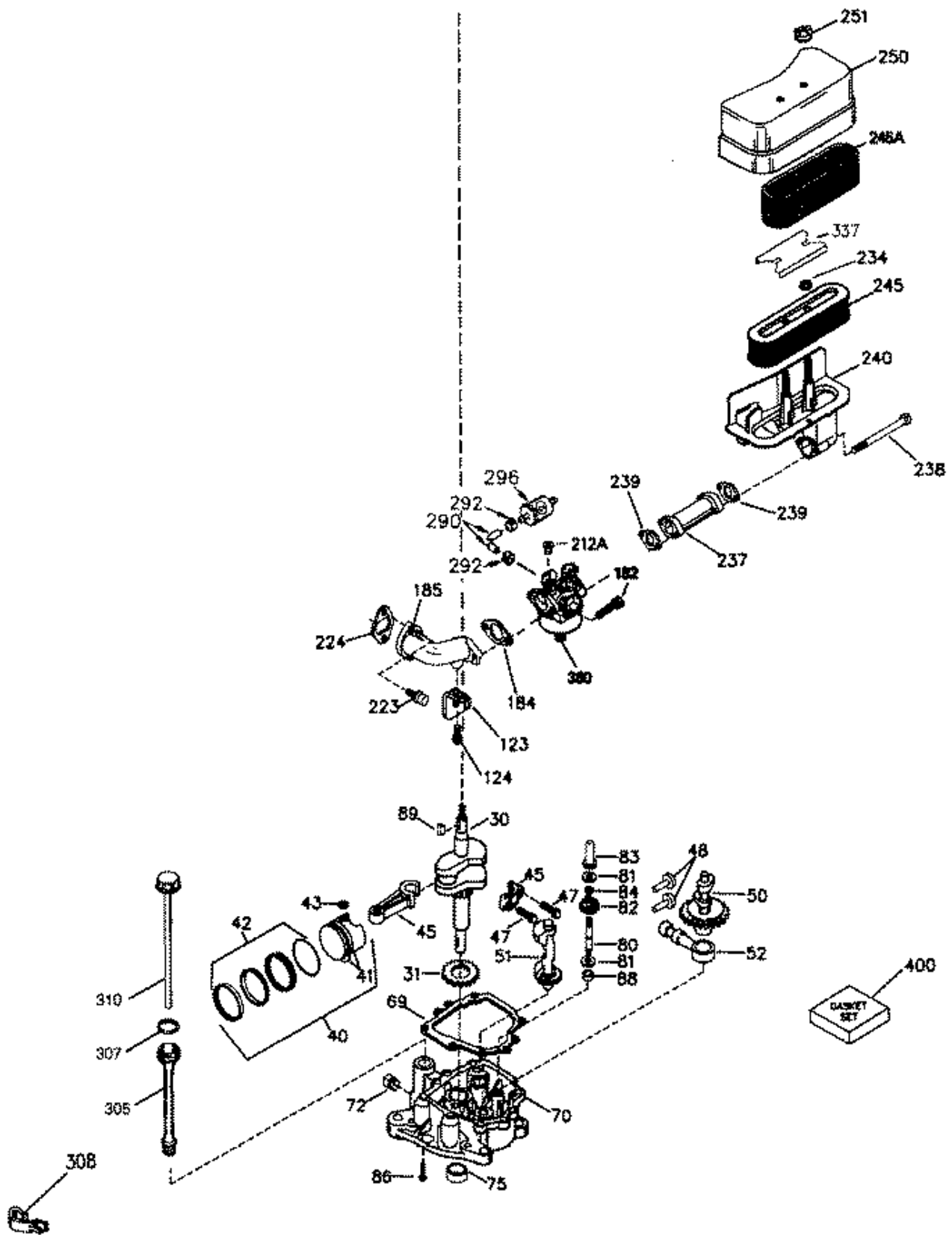

**MODEL 536.270212****ENGINE 143.981300 REPAIR PARTS**

Key No.	Description	Part No.	Key No.	Description	Part No.
1	Cylinder (Incl. 2 & 20)	35943A	68	Ground, Terminal	33356
2	Dowel Pin	27652	69	Mounting Flange Gasket	35317
14	Washer	28277	70	Mounting Flange (Incl. 72, 75 & 80)	35711A
15	Governor Rod	35324	72	Oil Drain Plug	31927
16	Governor Lever	36284A	75	Oil Seal	35319
17	Governor Lever Clamp	29916	80	Governor, Shaft	35712
18	Screw, 8-32 x 5/16"	651028	81	Washer	35479
19	Extension Spring	35945	82	Governor Gear Ass'y.	35321
20	Oil Seal	35319	83	Governor Spool	35322
25	Blower Housing Baffle	36460	84	Retaining Ring	29193
26	Screw, 1/4-20 x 5/8"	650561	86	Screw, 1/4-20 x 1-3/16"	650833
28	Lock Nut, 8-32	30322	88	Spacer	31707A
30	Crankshaft	35336B	89	Flywheel Key	32589
31	Counterbalance, Gear	35327	90	Flywheel (W/Ring Gear)	611093
35	Screw, 10-32 x 3/4"	29826	92	Lock Washer	650860
36	Lock Washer	29918	93	Flywheel Nut	650861
37	Lock Nut, 10-32	29216	100	Solid State Ignition	35135
38	Retaining, Ring	29642	101	Spark Plug Cover	610118
40	Piston, Pin & Ring Set (Std.)	35776A	102	Solid State Mounting Stud	651024
40	Piston, Pin & Ring Set (.010" OS)	35777A	103	Screw, Torx T-15, 10-24 x 15/16"	651007
40	Piston, Pin & Ring Set (.020" OS)	35778A	110	Ground Wire	35183
41	Piston & Pin Ass'y. (Std.) (Incl. 43)	35773A	119	Cylinder Head Gasket	35946
41	Piston & Pin Ass'y. (.010" OS) (Incl. 43)	35774A	120	Cylinder Head	35946
41	Piston & Pin Ass'y. (.020" OS) (Incl. 43)	35775A	123	Intake Pipe Brace	35288
42	Ring Set (Std.)	35779	124	Screw	651031
42	Ring Set (.010" OS)	35780	125	Exhaust Valve (Std.)	35308
42	Ring Set (.020" OS)	35781	125	Exhaust Valve (1/32" OS)	35433
43	Piston Pin Retaining Ring	35772	126	Intake Valve (Std.)	35309
45	Connecting Rod Ass'y. (Incl. 47)	36895	126	Intake Valve (1/32" OS)	35432
47	Connecting, Rod Bolt	651033	127	Washer	650691
48	Valve Lifter	35313	128	Belleville Washer	650690
50	Camshaft	35939	130	Screw, 5/16-18 x 2-1/2"	650946
51	Counterbalance Weight	35315A	135	Resistor Spark Plug (RJ4C)	34645
52	Oil Pump Ass'y.	31356	150	Valve Spring	33507
60	Blower Housing Extension	35316A	151	Valve Spring Keeper	33508
62	Screw, 8-32 x 3/8"	650760	153	Push Rod Guide	35949
63	Grommet	28545	154	Rocker Arm Stud	650945
65	Screw, 10-24 x 1/2"	650128	155	Rocker Arm	35950
66	Screw, Torx T-30	650990	156	Lock Washer	650890

**MODEL 536.270212****ENGINE 143.981300 REPAIR PARTS**

157	Lock Nut, 5/16-24	650947	265	Cylinder Head Cover	35959
158	Push Rod	35951	266	Screw, 5/16-18 x 1-1/4"	650876
159	Rocker Arm Cover Gasket	35952	269	Exhaust Manifold Gasket	35762
160	Rocker Arm Housing	35953A	270	Exhaust Manifold	36839
161	Screw, Torx T-30, 1/4-20 x 1/2"	30063	270A	Exhaust Port Liner	35829A
169	Valve Cover Gasket	27896A	271	Locking Plate	35293
170	Breather Body	28423	275	Muffler & Manifold	36542
171	Breather Element	28424	276	Locking Plate	35348
172	Valve Cover	28425	277	Screw, 5/16-18 x 4-1/2"	650877
173	Breather Tube	35350	290	Fuel Line (13.00")	30705
174	Screw, 10-24 x 1/2"	650128	292	Fuel Line Clamp	26460
180	Blower Housing Extension	35954	296	Fuel Filter (Incl. 292)	34279B
181	Screw, 10-24 x 9/16"	30200	305	Oil Fill Tube	35574
182	Screw, 1/4-20 x 27/32"	650517	307	"O". Ring	35499
184	Carburetor To Intake Pipe Gasket	33263	308	Fill Tube Clip	33997
185	Intake Pipe	35955	308A	Fill Tube Clip	35437
186	Governor Link	36285	310	Dipstick	35576
186A	Choke Link	35957	314	Screw, 1/4-20 x 3/4"	650873
200	Control Bracket (Incl. 203 & 204)	35956	315	Alternator Coil (3 Amp) (Incl. 321-323)	611116
203	Compression Spring	36482	321	Diode	611161
204	Screw, 6-32 x 2 1/32"	650777	322	Connector Body	611117
209	Screw, 10-32 x 7/16"	650902	323	Terminal	611118
210	Conduit Clip	27793	325	Wire Clip	34246
211	Screw, 10-32 x 3/8"	28942	326	Blower Housing Plug	36210
212A	Bushing	36286	337	Deflector	36407
223	Screw, Torx	650971	347	Screw, 10-32 x 9/16"	650949
224	Intake Pipe Gasket	35958	361	Screw, Torx T-30	650990
234	Nut & Lockwasher, 1/4-20	650825	363	Spring	34148
237	Air Cleaner Adapter	35286	370	Instruction Decal	36261
238	Screw	650875	370G	Instruction Decal	35274
239	Air Cleaner Gasket	33629	380	Carburetor (Incl. 184)	640115
240	Air Cleaner Body (Incl. 239)	35960	393	Cup and Screen	35962
245	Air Cleaner Filter (Incl. 234)	35403	394	Washer	650948
245A	Air Cleaner Filter	35404	395	Electric Starter Motor (12 Volt)	36680
250	Air Cleaner Cover	35961	400	Gasket Set: Includes 27896 (2), 33263 (1), 33629 (2), 34265 (1), 35317 (1), 35762 (2), 35946 (1), 35352 (1), 35958 (1).	35947
251	Wing Nut, 1/4-20	650886	414	Screen Kit (Optional)	35352
260	Blower Housing	35964	900	Replacement Engine, None	0
262	Screw, Torx T-30, 1/4-20 x 1/2"	30063	900	Replacement SB 752321, order from 71-999	0
263	Trim Ring	35963			
264	Screw, 5/16-18 x 5/8"	650273			
264A	Screw, Torx T-30, 1/4-20 x 1/2"	30063			

# MODEL 536.270212

# ENGINE 143.981300 REPAIR PARTS

Key No.	Description	Part No.	Key No.	Description	Part No.
0	Carburetor (Incl. 1A, 184 of Engine Parts List)	640115	47	Welch Plug, Idle Mixture Well	630748
1	Throttle Shaft & Lever Assembly	632649	48	Welch Plug, Atmospheric Vent	631027
1A	Bushing	36288			
2	Throttle Return Spring	632685			
4	Dust Seal Washer	631184			
5	Dust Seal	631183			
6	Throttle Shutter	632517			
7	Shutter Screw	650506			
10	Choke Shaft & Lever Assembly	632472			
11	Choke Return Spring	632473			
12	Dust Seal Washer	631184			
13	Dust Seal	631183			
14	Choke Shutter	632429A			
16	Fuel Fitting	632527			
17	Throttle Crack Screw / Idle Speed Screw	651025			
18	Tension Spring	630768			
20	Idle Restrictor Screw	640018			
20A	Idle Restrictor Screw Cap	640053			
25	Float Bowl	631867			
27	Float Shaft	631024			
28	Float	632019			
29	Float Bowl "O" Ring	631028			
30	Inlet Needle, Seat, & Clip	631021			
31	Spring Clip	631022			
36	Main Nozzle Tube	640005			
37	"O" Ring, Main Nozzle Tube	632547			
40	High Speed Bowl Nut	640116			
44	Bowl Nut Washer	27110			

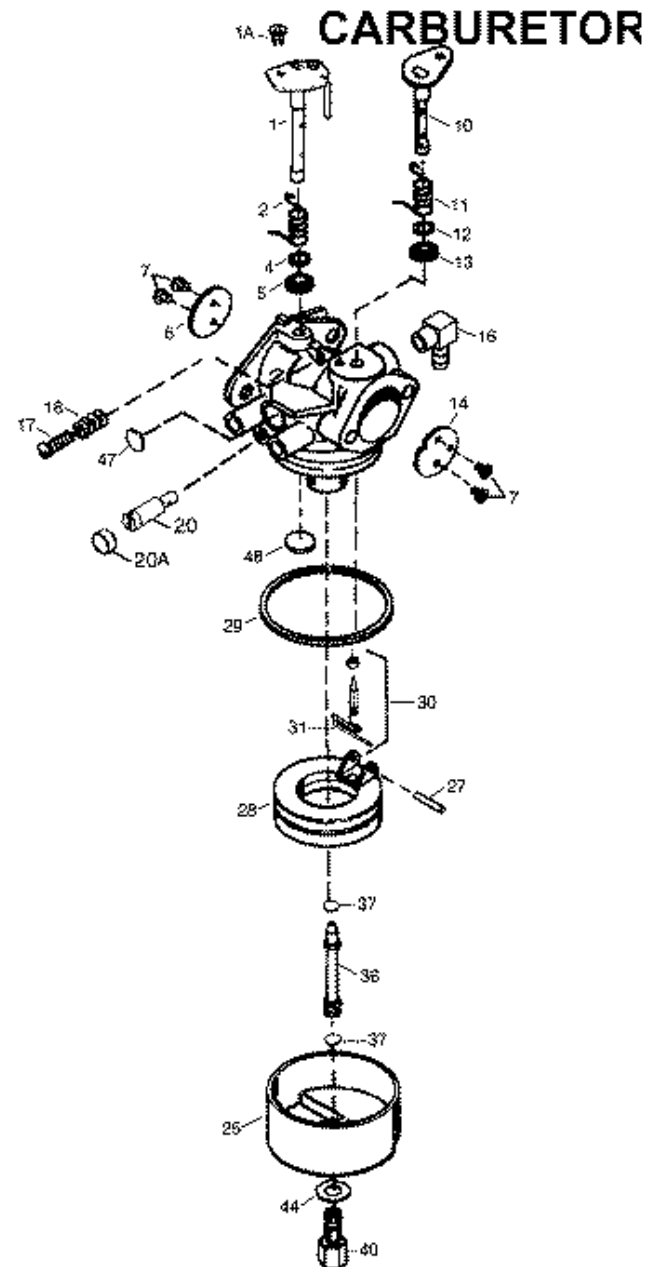

# MODEL 536.270212

# ENGINE 143.981300 REPAIR PARTS ELECTRIC STARTER

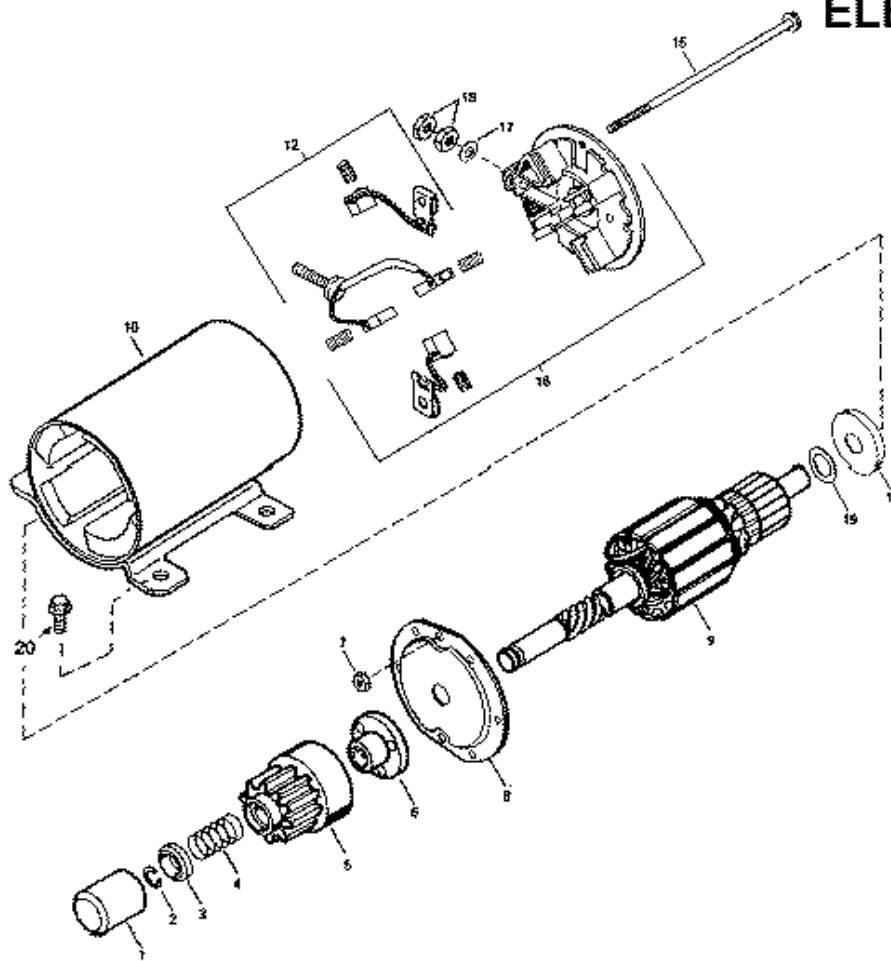

Key No.	Description	Part No.
0	Electric Starter	36680
1	Dust Cover	33451
2	Retainer Ring	33842
3	Spring Retainer	33430
4	Anti-drift Spring	33854
5	Gear	33432
6	Nut & Retainer	35893
7	Lock Nut	33450
8	Drive End Cap Assly.	35894
9	Armature	35895
10	Housing Ass'y	36699
12	Brush & Spring Kit	35896
14	Thrust Washer	35897
15	Bolt, 10-32 X 4-11/64"	35898
16	End Cap & Brush Card Ass'y. (Incl.12,14,17,18)	35899
17	Washer	650168
18	Nut	650864
20	Screw, Torx T-30, 1/4-20 x 15/32"	650990

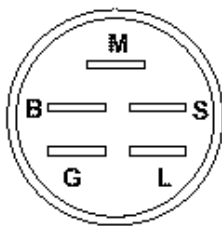
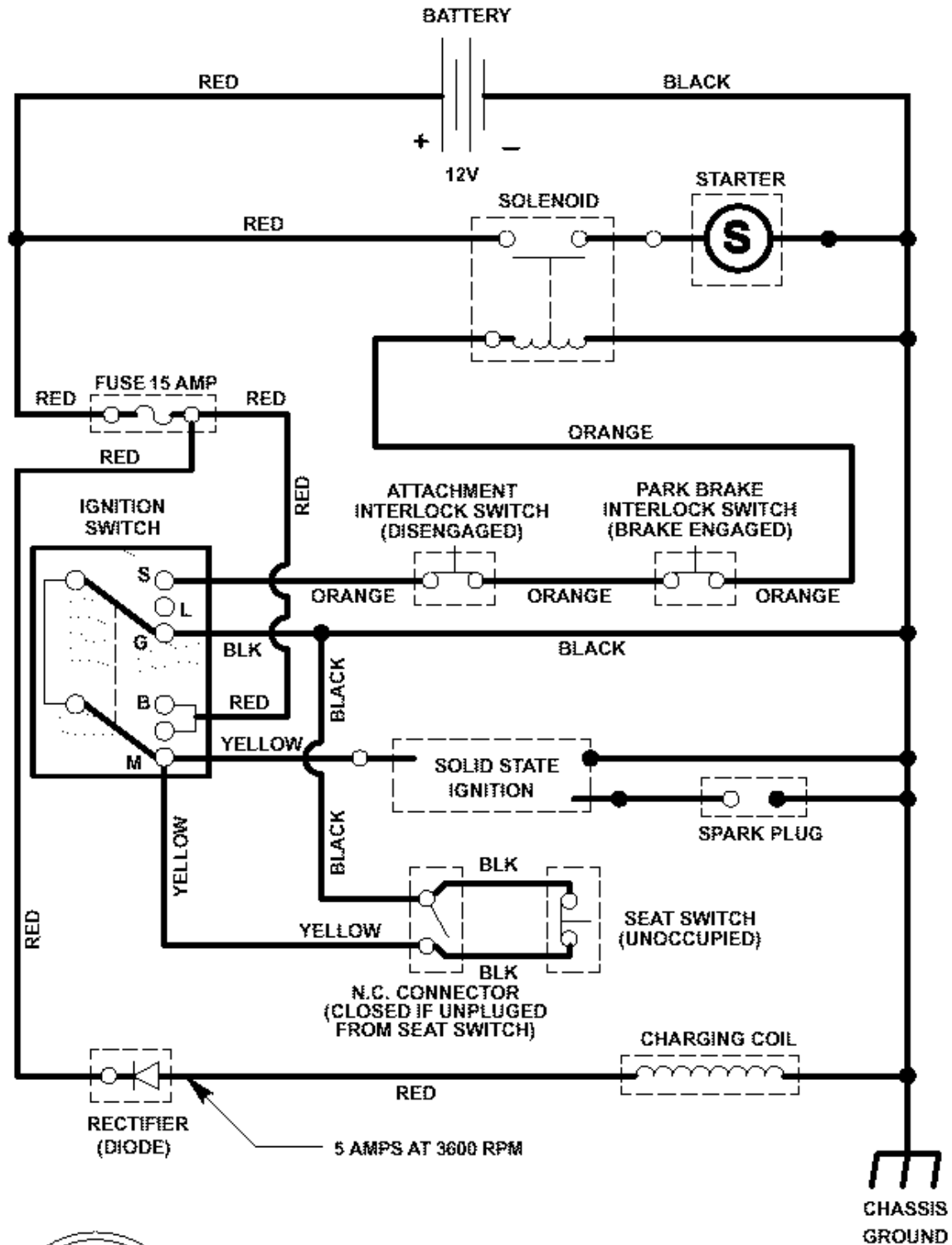

POSITION	FUNCTION	CIRCUIT
3	Start	B + S
2	Run	B + L
1	Off	G + M

---

## NOTES

---

---

## NOTES

---

---

## NOTES

---

# SEARS

## owner's manual

**Model No.  
536.270212**

### To Call Toll Free

**For Service  
1-800-4-REPAIR  
(1-800-473-7247)**

**For Parts  
1-800-366-PART  
(1-800-366-7278)**

# CRAFTSMAN

## 13.5 HP. ELECTRIC START 30" MOWER / MULCHER 5 SPEED REAR ENGINE RIDER

The Model Number for the mower is found on a decal attached to the back of the frame. The Model Number for the engine is found on the blower housing above the spark plug. Always give the Model Number when you call for service or order repair parts for your unit.

Repair parts can be ordered from any Sears Service Center/Department and most Sears Stores.

WHEN ORDERING REPAIR PARTS, ALWAYS HAVE THE FOLLOWING INFORMATION AS SHOWN IN THIS LIST.

- PRODUCT – REAR ENGINE RIDER
- MODEL NUMBER – 536.270212
- ENGINE MODEL NO. 143.981300
- PART NUMBER
- PART DESCRIPTION

Your Sears merchandise has added value when you consider Sears has service units nationwide staffed with Sears trained technicians. Sears technicians have the necessary parts, tools and equipment to meet the Sears pledge, "We Service What We Sell".