

TOPENS[®]

**A5/A8
A3S/A5S/A8S**

Installation Manual

For single swing gate installation

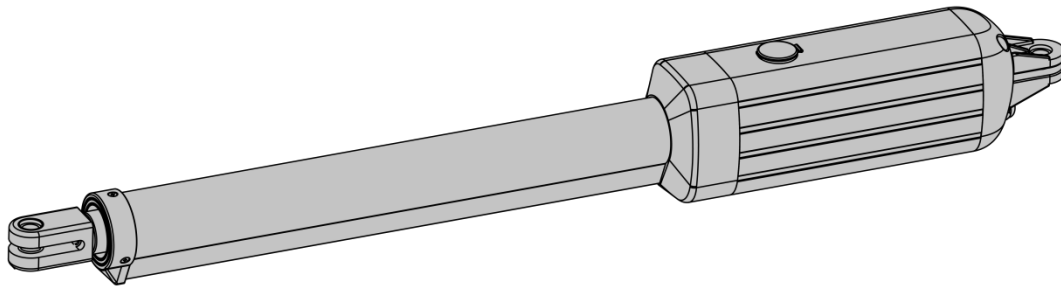

Installation Video



This series gate opener can be powered by batteries, add the 24V 12Ah automotive / marine type battery (required but not included) as the main power source. You can use the adapter, or solar panel & solar controller (optional), or both at the same time to charge the battery.

CONTACT US

For Technical Support and Installation Assistance

Visit our website at www.topens.com and fill out the online form

Alternatively, you can send an email to our service team at support@topens.com

To ensure prompt and effective assistance, kindly include the following information in your email:

- **Where Did You Purchase?** _____
- **Order Information** _____
- **Your Contact Information** _____
- **Gate Information (Weight and Length Per Leaf)** _____
- **Did You Purchase Any Accessories? (If Yes, Please List Them)** _____
- **Issue Description (Include Any Relevant Photo or Video)** _____

For Warranty Registration

To register your warranty, please visit www.topens.com

If you have any questions regarding what is covered by the TOPENS warranty, refer to the detailed policy at www.topens.com/pages/topens-limited-warranty.

Email Us: support@topens.com

Table of Contents

Important Safety Information	1
Packing List	4
Installation Overview	5
Specifications	6
Before You Begin	7
Pull-to-Open Gate Opener Mounting	9
Push-to-Open Gate Opener Mounting	13
Mount Control Box	17
Terminal Function of the Control Board	18
Connect the Arm to the Control Board	19
Connection of Power Supply	20
Program the Remote Control	24
Adjust the Limit Switch	25
Setting of the Control Board	26
Stall Force Adjustment & Obstruction Test	28
Connection of Accessories	29
TC188 Universal Keypad.....	29
TKP3 Wireless Keypad.....	31
TC173 Wireless Push Button.....	32
TC196 Tuya WiFi Remote Control.....	32
ET24 Electric Gate Lock	33
TEW3 Vehicle Sensor Exit Wand.....	34
TC175P Wired Keypad.....	35
HLR01 Homelink Remote Control Kit.....	35
JD24VY Warning Light.....	36
TRF3 Reflection Photocell Sensor.....	36
TC102 Infrared Photocell Sensor.....	37
ERM12 External Receiver	38
TC148 Waterproof Wall Push Button & TC147 Wall Push Button	38
Maintenance and Replacement Parts	39
Gate Opener Status Trouble Shooting	40

Important Safety Information

Product Usage

TOPENS gate opener meets all safety requirements for a Class I Residential Vehicular Gate Operator, and is only for use on vehicular access gates, not pedestrian gate applications.

Before Installation

- ◆ **GAIN UNDERSTANDING OF THE INSTALLATION PROCESS:** Please read this installation manual or view our online installation video before installing the gate opener.
- ◆ **LOCAL INSTALLATION COMPLIANCE:** Prior to installation, please verify that your planned installation complies with all relevant local building codes and ordinances. Dispose of packaging materials in accordance with local regulations.
- ◆ **SEPARATE PEDESTRIAN ACCESS:** The gate opener is intended for installation only on gates used for vehicles. Pedestrians should use a separate entrance to avoid contact with the moving vehicular gate.

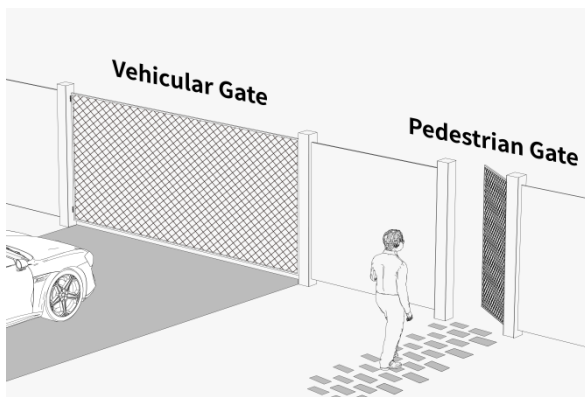

- ◆ **SWING GATE PREPARATION:** Do not attach wheels to the gate. Ensure that the gate is plumb, level, and swings freely on its hinges without binding or dragging on the ground. The gate should be mounted to a very stable post or column that is secured in the ground with concrete. If the post's width or diameter is under 15cm (6"), it should be either metal or set in cement. This ensures stability and minimizes the twisting effect caused by gate movement.

Repair or replace all worn or damaged gate hardware prior to installation.



- ◆ **ENTRAPMENT ZONES ASSESSMENT:** Identify all entrapment zones specific to your installation type. These zones are areas around the automatic gate system where a person or object could be caught that increase the risk of injury. Verify that entrapment areas are clear of potential obstructions before installing the gate opener.

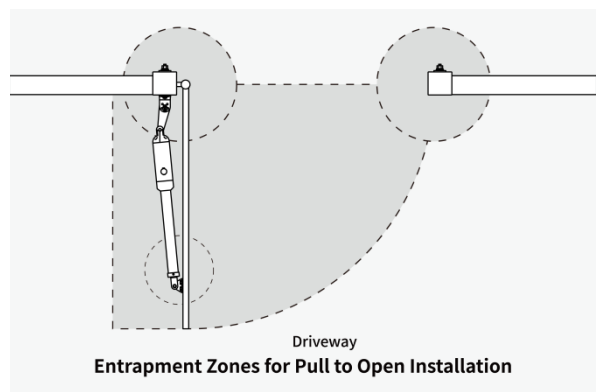

- ◆ **AVOID SOLID PANEL GATES:** The gate opener works with various gate types. Solid panel gates have a higher resistance to wind and may result in damage to the gate opener. Therefore, it is not recommended to use the opener with solid surface gates.

Important Safety Information

During Installation

- ◆ **INSTALLER AND END USER RESPONSIBILITY:** An experienced installer should perform the installation. Improper installation may result in property damage, severe injury or death. The gate opener is only part of the entire gate operating system, and it is the responsibility of the installer and end user to ensure that the total system is safe for its intended use.
- ◆ **DISCONNECT THE POWER SUPPLY:** Ensure that the gate opener is powered off before electrical wire connections or making any adjustments.
- ◆ **AVOID ENTRAPMENT ZONES:** Keep children, pets or livestock away from the entrapment zones to avoid the risk of injury or death.
- ◆ **INSTALL INSIDE PROPERTY BOUNDARIES:** Install the gate opener on the inside of the property. Do not install outside of the gate where the public has access to it.
- ◆ **INSTALL SAFETY SENSOR:** The gate opener is designed to stop and reverse the gate when the gate comes in contact with an obstruction. It is highly recommended to install a photocell sensor in the following

situations for safety: if you have children or pets at your property, the gate opener auto close function is set to ON, the gate opener stall force is set to the maximum, a vehicle exit sensor is installed, or other gate control devices are used.

- ◆ **GATE CONTROL ACCESSORIES PLACEMENT:** Gate control accessories intended for user activation must be located at least 1.5 meters (5') away from any moving part of the gate and where the user is prevented from reaching over, under, around or through the gate to operate the controls. Outdoor or easily accessible controls shall have a security feature to prevent unauthorized use.

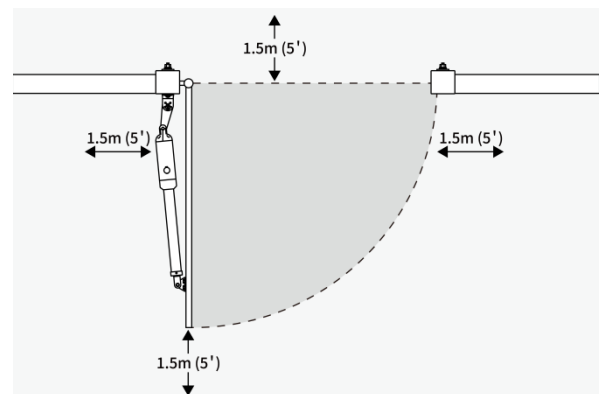

After Installation

- ◆ **WARNING SIGNS:** Attach the provided warning signs to both sides of the gate to alert the public about the automatic gate opener system. If your signs are damaged, please reach out to TOPENS Customer Support for replacements.

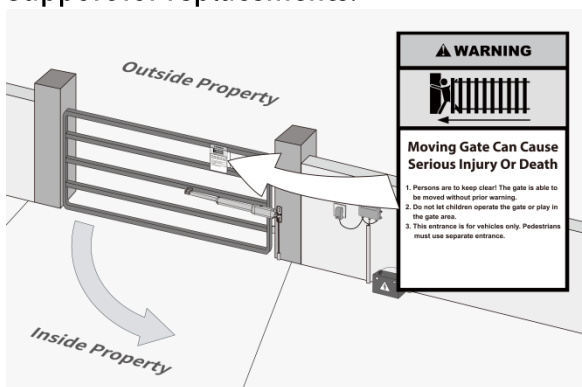

- ◆ **AWAY FROM MOVING GATES:** Keep children, pets and livestock away from the gate opener system as moving gates can be dangerous.
- ◆ **SECURE GATE CONTROL ACCESSORIES:** Prevent children from operating gate controls by keeping remote transmitters, keypads, and push buttons out of their reach. Store in a secure area when not in use.
- ◆ **MAINTENANCE OF GATE OPENER SYSTEM:** Regularly maintain the gate and gate opener system to ensure that the gate swings freely and remains level throughout

Important Safety Information

its entire swing path. Periodically check your posts, adjusting brackets or tightening hardware as needed. Turn off the power to the gate opener before performing any maintenance.

- ◆ **OBSTRUCTION PROTECTION TESTING:** Test the gate opener monthly. The gate must reverse or stop on contact with a rigid object or when an object activates the non-contact sensors. After adjusting the force or limit travel, retest the gate opener. Failure to adjust and retest the gate opener properly can increase the risk of injury or death.
- ◆ **POWER DISCONNECTION AND MANUAL**

OPENING: Understand how to disconnect the power and manually open the gate. Disconnect the gate opener from the gate only when the gate is not in motion and the gate opener system is turned off.

- ◆ **RECOGNIZE POTENTIAL RISKS IN AUTOMATED GATE SYSTEMS:** Save the installation manual. Make sure everyone who is using or will be around the gate and gate opener are aware of the dangers of automated gate systems. If a replacement manual is needed, you can download a copy from the TOPENS website (www.topens.com).

Note For Warranty

- ◆ **WARRANTY LIMITED TO TARGET MARKET:** The warranty is limited to the target market (Contiguous United States, Canada, UK, and Germany). Customers using the product outside these regions will be responsible for any additional expenses during the warranty replacement process.
- ◆ **GATE OPENER ABUSE:** TOPENS does not cover damage resulting from abuse, such as attempting to operate the gate opener beyond its specified capacity or using it for unintended purposes.
- ◆ **GATE OPENER MISUSE:** TOPENS does not cover damage resulting from misuse, including but not limited to operating the gate opener with incompatible power sources or using it in environments not recommended by TOPENS.
- ◆ **ALTERATIONS OR MODIFICATIONS:** Alterations or modifications made to the gate opener without prior consultation with TOPENS will also invalidate warranty coverage.
- ◆ **NON-COMPLIANCE WITH INSTRUCTIONS:** Failure to follow the installation instructions, including but not limited to

improper installation, maintenance will void the warranty.

- ◆ **THIRD PARTY ACCESSORIES:** TOPENS does not cover damage caused by third party accessories, except those specifically recommended by TOPENS Customer Support. It is important to use only compatible accessories to ensure compatibility and prevent damage to the gate opener.
- ◆ **CONTACT TOPENS SUPPORT:** Please ensure that the gate opener is installed, operated, and maintained in accordance with the guidelines outlined in the installation manual to avoid voiding the warranty. If you have any questions regarding proper usage or need assistance with compatible accessories, please contact TOPENS Customer Support for guidance.
- ◆ **DETAILED WARRANTY POLICY:** If you have any questions regarding what is covered by the TOPENS warranty, refer to the policy at www.topens.com/pages/topens-limited-warranty.

Packing List

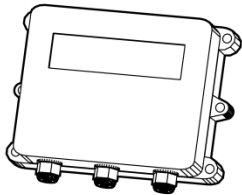

Control Box



TS24-U Adapter

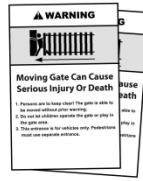

Warning Sign



Gate Bracket

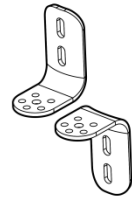

Post Bracket

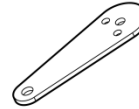

Pull-to-Open Bracket

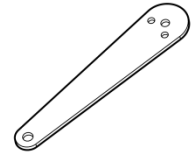

Push-to-Open Bracket

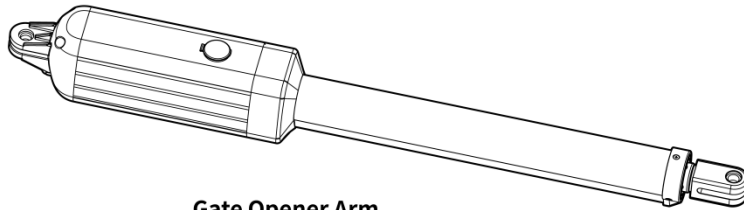

Gate Opener Arm



Remote Control

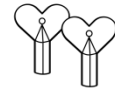

Release Key

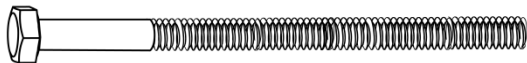

M10x200 Bolt (4)



12x40 Clevis Pin (1)



12x30 Clevis Pin (1)



M10x75 Bolt (2)



M10x35 Bolt (1)



Hairpin Clip (2)



Φ10 Lock Washer (7)



M8x30 Bolt (1)



Φ10 Washer (7)



Φ8 Washer (1)



M10 Nut (7)



M8 Nut (1)

Extra Part for A3S / A5S /A8S

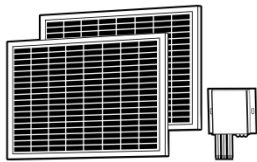

2 x 10W 24V Solar Panel &
1 x Solar Charge Controller

Safety Accessories

(Included in Specific Models, Check the Actual Package)

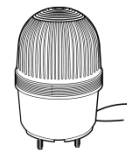

JD24VY
Warning Light

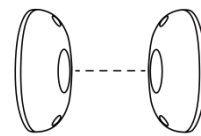

TC102 Infrared
Photocell Sensor

Installation Overview

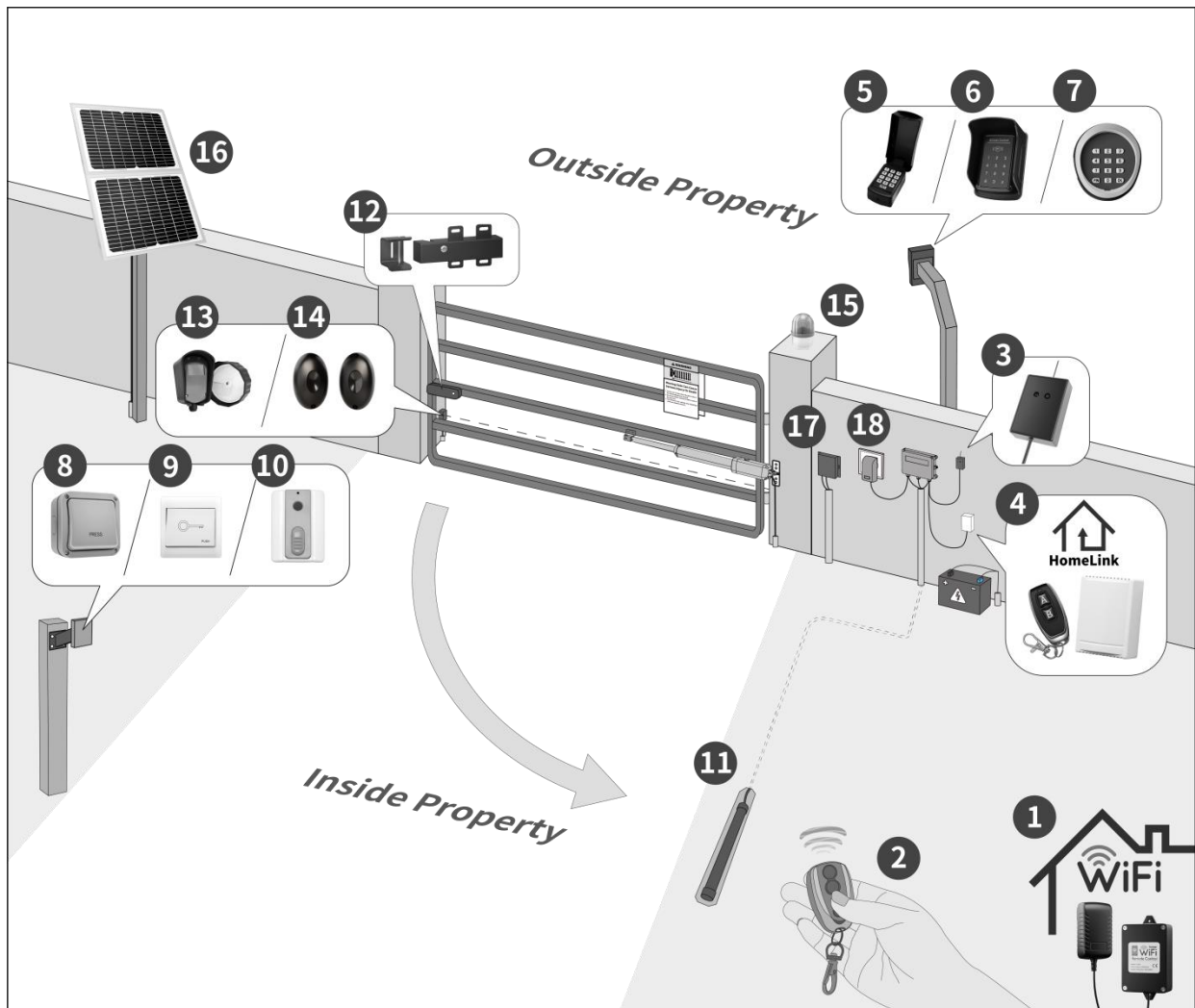

Example of Pull-to-Open Installation

Various TOPENS Accessories for Your Gate Opener System

❶ TC196 WiFi Remote Control	❷ TC173 Wireless Push Button
❸ M12 Remote Control	❹ TEW3 Vehicle Sensor Exit Wand
❺ ERM12 External Receiver	❻ ET24 Electric Gate Lock
❻ HLR01 Homelink Remote Control Kit	❼ TRF3 Reflection Photocell Sensor
❽ TC188 Universal Keypad	❽ TC102 Infrared Photocell Sensor
❾ TC175P Wired Keypad	❾ JD24VY Warning Light
❿ TKP3 Wireless Keypad	❿ TSQ20W 20W Solar Panel Kit
⓫ TC148 Waterproof Wall Push Button	⓫ TCS3 Solar Charge Controller
⓬ TC147 Wall Push Button	⓬ TS24-U Adapter

* Available on the TOPENS website (www.topens.com) and Amazon.

Specifications

Product Model	A3S	A5(S)	A8(S)
Power Input	Adapter Input: 100-240V ~ 50/60Hz		
Motor Voltage	24VDC		
Rated Current	1.5A	2A	3A
Motor Power	30W	50W	80W
Gate Opening / Closing Time	15 seconds (ideal condition)		
Gate Opening / Closing Speed	16mm/s (0.6 in/s)		
Max Travel Range	385mm (15.2 in)		
Working Temperature	-20°C ~ +50°C (0°F to 120°F)		
Protection Class	IP44 Waterproof		

Max Gate Weight and Gate Length

NOTE: Ball bearing hinges should be used on all gates weighing over 140kg (300lbs).

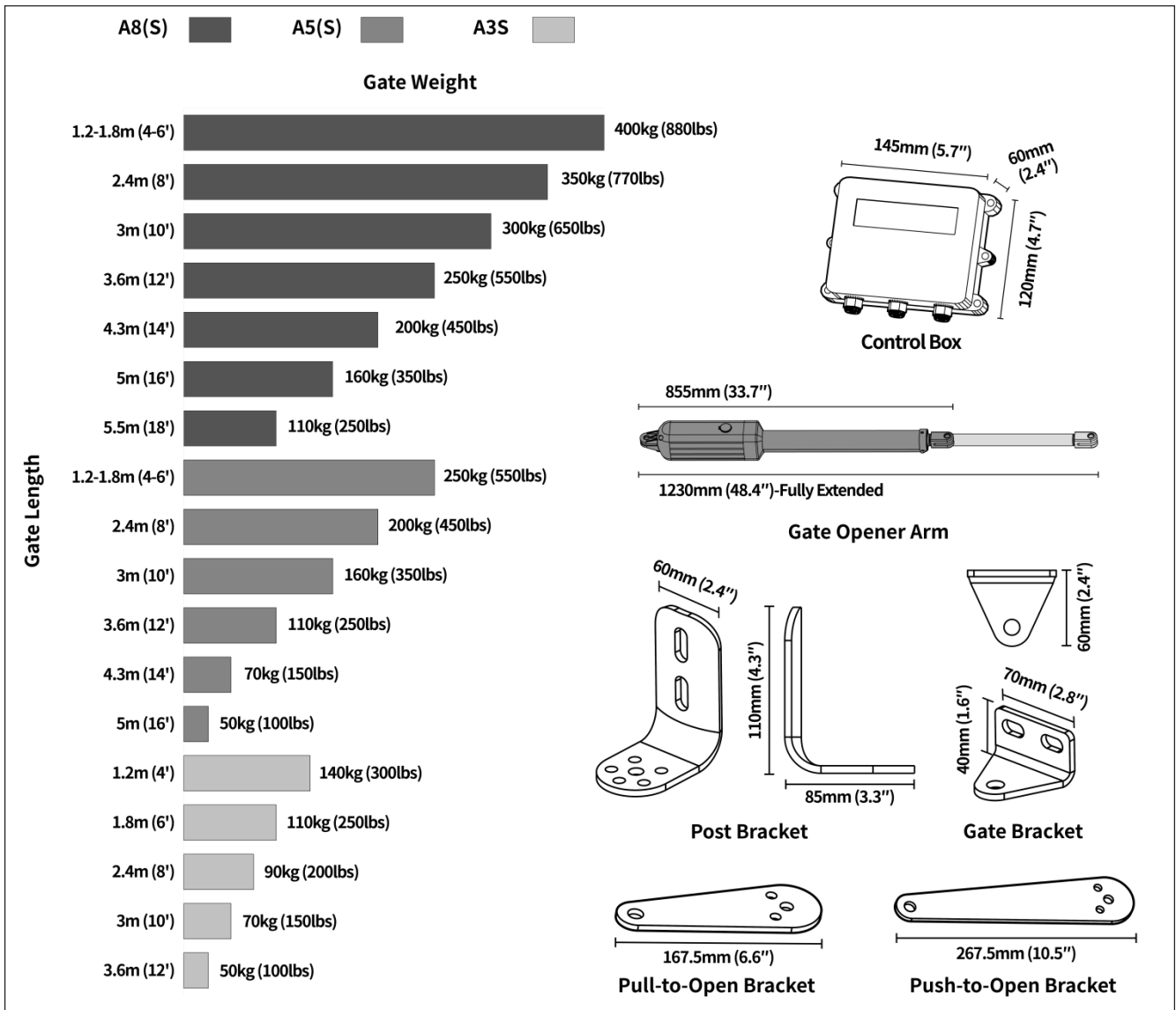

Before You Begin

Check the Gate

- ◆ Ensure that the gate is plumb, level, and swings freely on its hinges without binding or dragging on the ground.
- ◆ The gate should be mounted to a very stable post or column that is secured in the ground with concrete.
- ◆ Repair or replace all worn or damaged gate hardware prior to installation.

Tools Needed

- ◆ Power Drill
- ◆ Wire Strippers
- ◆ Level
- ◆ Phillips Screwdriver
- ◆ Tape Measure
- ◆ C-Clamps - small, medium, and large
- ◆ Hacksaw or Heavy Duty Bolt Cutters
- ◆ Open End Wrenches - 14# & 17# or Adjustable Wrenches

Items Not Included but May Needed

- ◆ **Battery and Solar Panel:** If you choose to use batteries and solar panels as main power source, you'll require 24V 12Ah battery (NOT included). Marine / automotive type battery or lead acid / GEL / AGM / flooded (deep cycle battery) batteries are supported, EXCEPT for lithium-ion battery. The batteries should be waterproof, or they should be placed in waterproof housing. Two 10W solar panels and one solar charge controller are included in A3S/A5S/A8S. If additional solar panel is needed, TOPENS solar panel kit is available for separate purchase.
- ◆ **PVC Conduit:** Required to protect the cable connecting TC102 infrared photocell sensor to the control board.
- ◆ **Connection Cable:** Connection cable may be required for power supply connection and wired accessories installation. Refer to the Connection of Power Supply and Connection of Accessories sections in this manual to purchase the correct cable.
- ◆ **Weatherproof Cover:** Use a weatherproof cover to protect the electrical outlet if it is located outdoors.
- ◆ **Surge Protector:** A surge protector with a rated current of 5A is recommended to use with the TS24-U adapter or power supply (sold separately).

Install Electric Gate Lock

- ◆ In windy areas, it is crucial to use an electric gate lock to ensure the gate remains securely closed and to prevent damage or malfunction caused by strong winds.

Install Photocell Sensor

- ◆ It is highly recommended to install a photocell sensor in the following situations for safety: if you have children or pets at your property, the gate opener auto close function is set to ON, the gate opener stall force is set to the maximum, a vehicle exit sensor is installed, or other gate control devices are used.

Before You Begin

Additional Hardware to Enhance Post Bracket Stability

- ◆ Ensure that the bolts to attach post bracket to wooden post are long enough to pass through the entire post.
- ◆ Add metal plate or larger washer between the bolt and the wooden post to improve bracket stability.
- ◆ For concrete post, use expansion bolts to securely mount the bracket.
- ◆ If the post's width or diameter is under 15cm (6"), it should be either metal or set in cement.

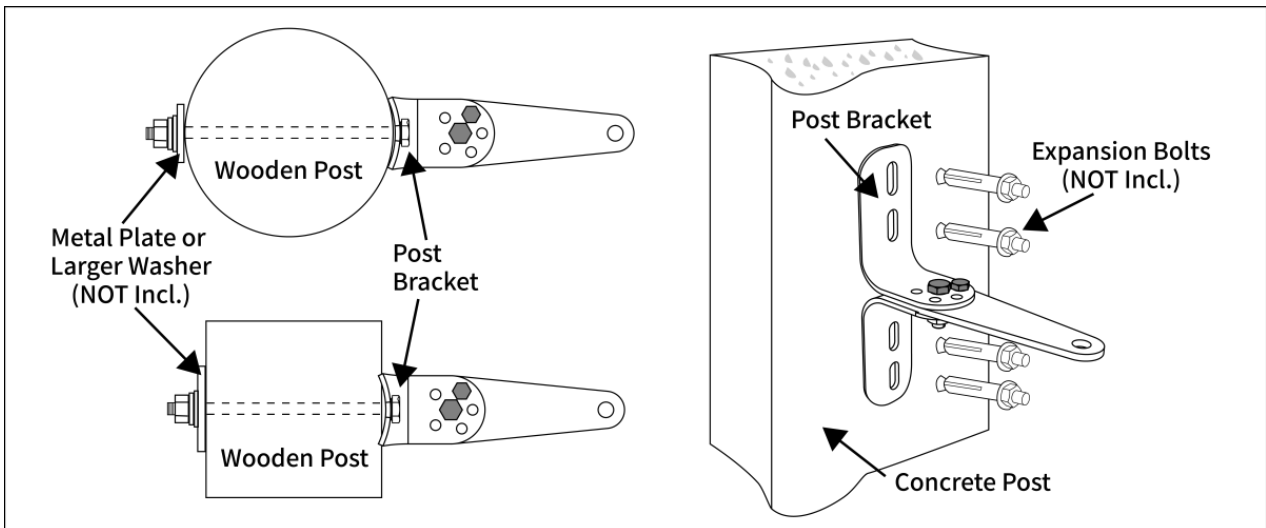

Check Gate Swing Direction

- ◆ Each gate is unique and the following steps outline common installation process.
- ◆ Please ensure that the PULL/PUSH TO OPEN setting on the control board matches the installation type.

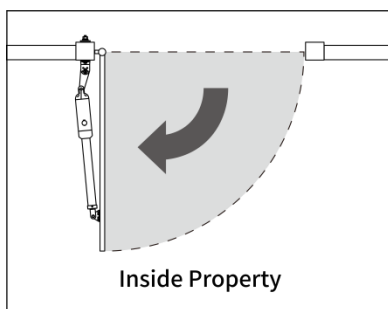

Pull-to-Open Installation Starts from Page 9

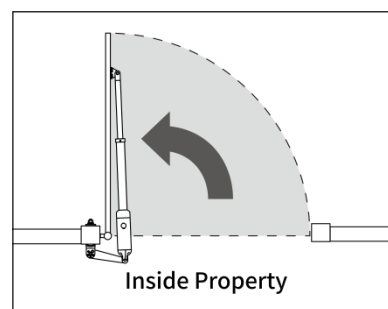

Push-to-Open Installation Starts from Page 13

NOTE: Improper installation may result in property damage, severe injury, and / or death.



Pull-to-Open Gate Opener Mounting

STEP 1

Assemble the Post Bracket and the Pull-to-Open Bracket

- ◆ Insert the bolts through the holes of post bracket and pull-to-open bracket, and fasten with washer and nut as shown.
- ◆ DO NOT over tighten the nut because the post bracket may need to be adjusted later.

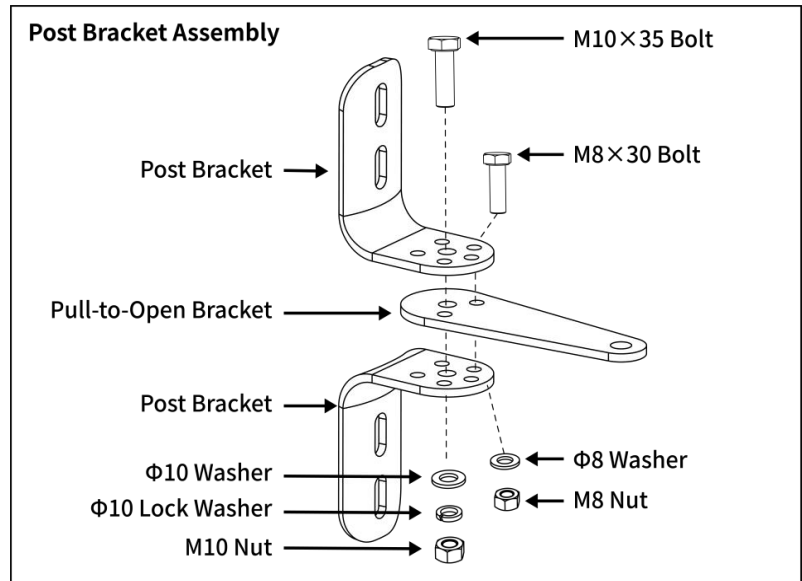

STEP 2

Determine the Position of the Post Bracket Assembly

- ◆ The table shows the maximum opening angle of the gate based on the dimensions of A and B. For example, if A is 16cm (6.3") and B is 14cm (5.5"), the maximum opening angle of the gate is 110°.
- ◆ Measure the dimension of A and B to determine the desired gate opening angle, and then mark the center of the mounting locations for the post bracket accordingly.
- ◆ **Pull-to-Open Installation** — Gate in open position with the moving rod fully retracted.

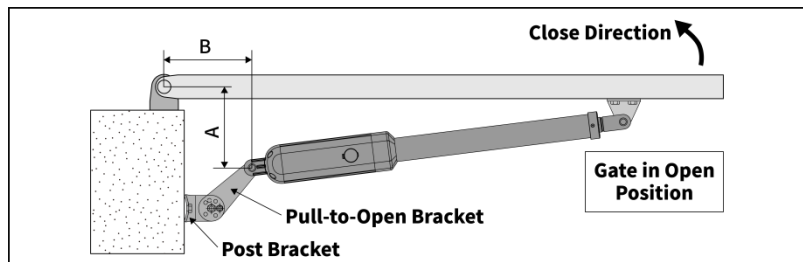

B \ A	10cm (3.9")	12cm (4.7")	14cm (5.5")	16cm (6.3")	18cm (7.1")	20cm (7.9")	22cm (8.7")	24cm (9.4")	26cm (10.2")
10cm (3.9")	90°	99°	106°	116°	118°	120°	111°	104°	100°
12cm (4.7")	90°	98°	105°	113°	116°	112°	105°	99°	95°
14cm (5.5")	90°	97°	104°	110°	111°	105°	99°	94°	91°
16cm (6.3")	90°	96°	103°	109°	103°	99°	94°	90°	87°
18cm (7.1")	90°	95°	101°	103°	96°	93°	89°	86°	83°
20cm (7.9")	90°	95°	99°	95°	90°	87°	84°	81°	79°
22cm (8.7")	90°	94°	95°	88°	84°	82°	80°	78°	76°
24cm (9.4")	90°	93°	87°	82°	79°	78°	76°	74°	73°
26cm (10.2")	90°	87°	81°	77°	75°	73°	72°	71°	70°
28cm (11")	84°	79°	75°	73°	71°	69°	69°	68°	68°



Pull-to-Open Gate Opener Mounting

STEP 3

Attach the Brackets to the Gate Opener Arm

- ◆ Attach the post bracket assembly and the gate bracket to the gate opener arm by inserting a clevis pin.
- ◆ Secure the clevis pin using the hairpin clip.

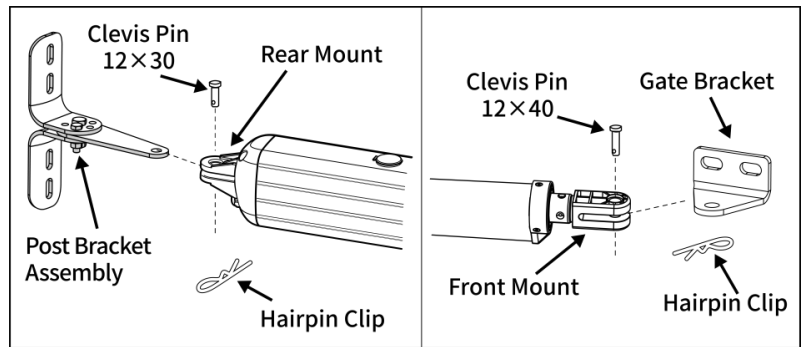

STEP 4

Release the Clutch

- ◆ Open the release hole plug on the top of the gate opener.
- ◆ Insert the manual release key, and turn it 90° clockwise.
- ◆ The gate opener is now in manual mode, allowing for manual extension and retraction of the moving rod.

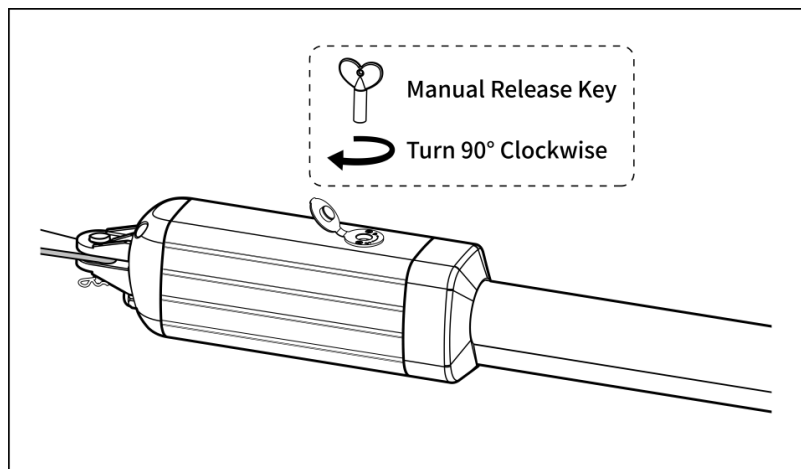

STEP 5

Position the Gate Opener on the Gate

- ◆ Clamp the gate opener arm along with the post bracket assembly to the marked position on the gate post.
- ◆ Make sure that the gate opener arm is fully retracted and the gate is fully opened to the desired position.
- ◆ Put a level on the arm, then use a C-clamp to secure the gate bracket onto the gate when the arm is level.

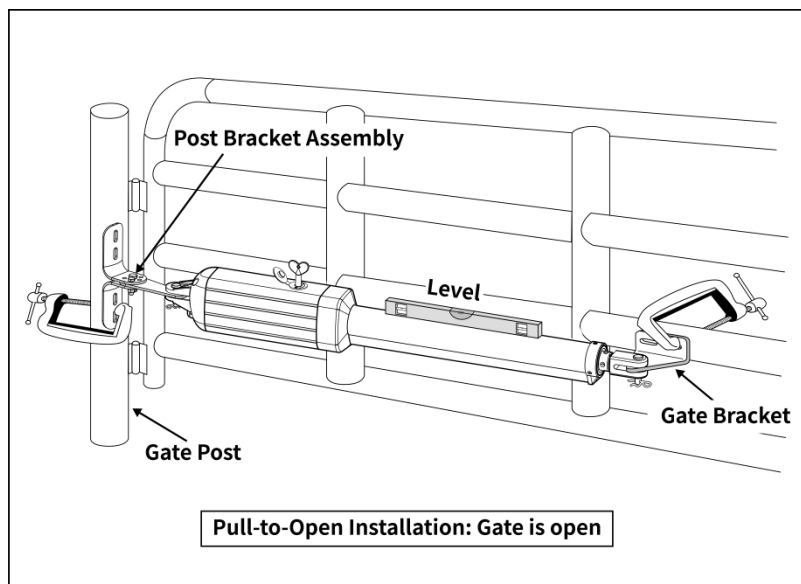



Pull-to-Open Gate Opener Mounting

STEP 6

Test Gate Travel and Mark the Brackets Mounting Locations

- ◆ Manually open and close the gate to ensure that the gate bracket position is correct.
- ◆ Ensure that there is a minimum clearance of 2.5cm (1") between the gate and the opener.
- ◆ Make sure that the gate opener does not bind against the pull-to-open bracket.
- ◆ If the clearance is less than 2.5cm (1"), or if the gate opener and the pull-to-open bracket are binding, rotate the pull-to-open bracket and/or move the post bracket assembly.
- ◆ Mark the center of the mounting locations for the brackets.

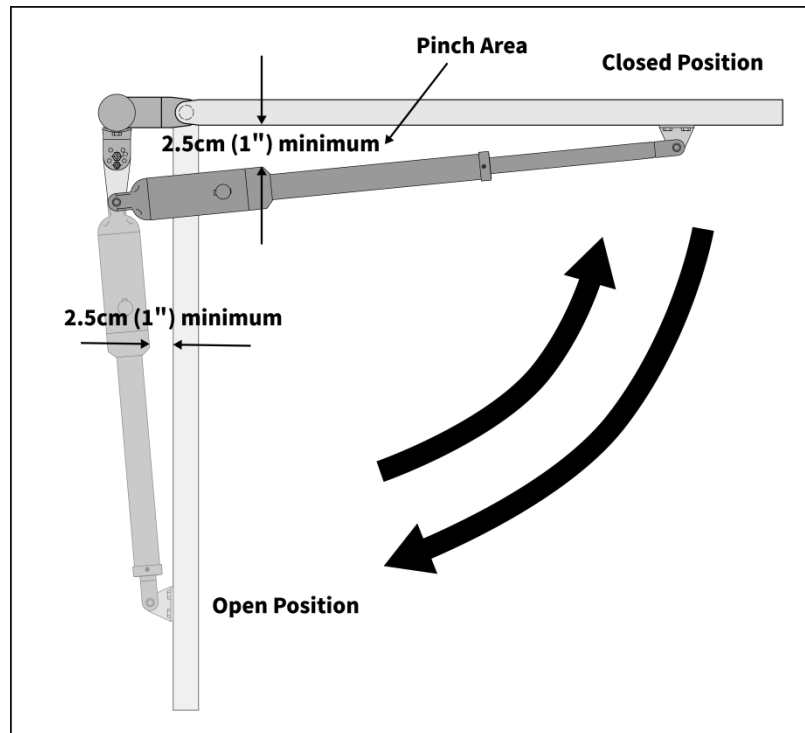

NOTE: This step is very important for determining the position of the gate opener arm and the gate opening angle. It is highly recommended to watch our step-by-step installation video on YouTube for guidance.

STEP 7

Drill Bracket Mounting Holes

- ◆ Remove the C-clamps and the gate opener arm.
- ◆ Drill 10.5mm (0.4") diameter holes through the post and the gate at the marked locations.

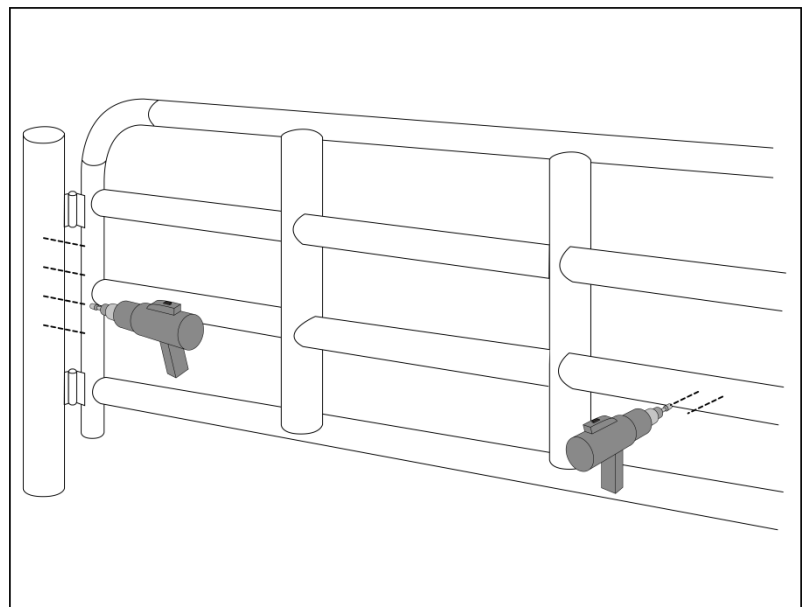



Pull-to-Open Gate Opener Mounting

STEP 8

Secure the Post Bracket

- ◆ Secure the post bracket assembly to the gate post by inserting M10 x 200 bolts through the post bracket assembly and the drilled holes in the gate post.
- ◆ Tighten each bolt using one ϕ 10 washer, one ϕ 10 lock washer, and one ϕ 10 nut. Cut off the bolts that extend beyond the tightened nuts.

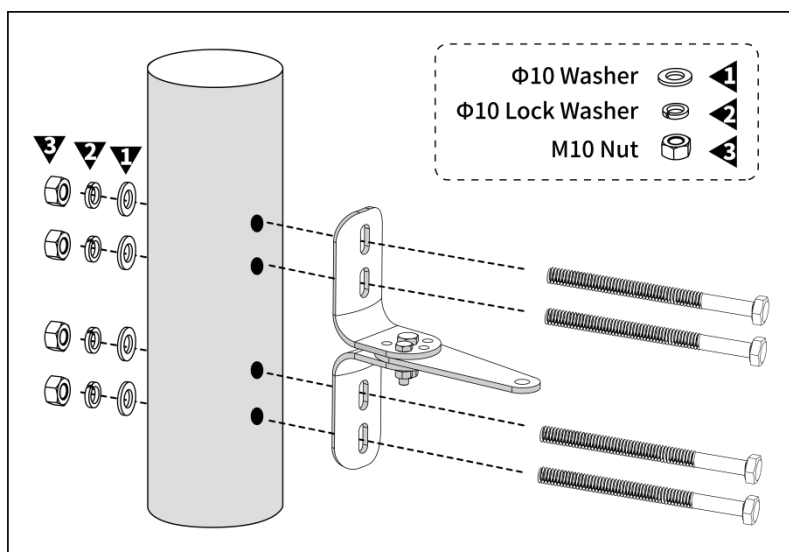

STEP 9

Secure the Gate Bracket

- ◆ Secure the gate bracket to the gate by inserting two M10 x 75 bolts through the gate bracket and the drilled holes in the gate.
- ◆ Tighten each bolt using one ϕ 10 washer, one ϕ 10 lock washer, and one ϕ 10 nut. Cut off the bolts that extend beyond the tightened nuts.

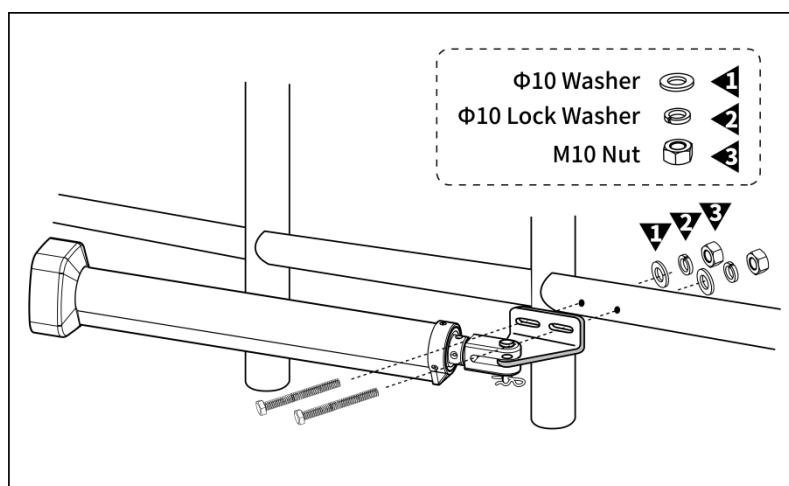

STEP 10

Turn Back the Clutch

- ◆ Manually move the gate to verify that if the installation is appropriate.
- ◆ Turn the release key 90° counterclockwise.

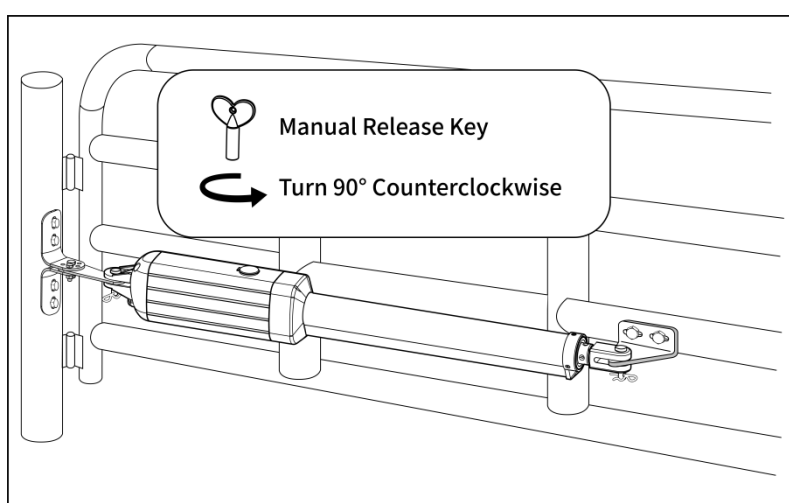

NOTE: Please ensure that the PULL/PUSH TO OPEN setting on the control board matches the installation type.



Push-to-Open Gate Opener Mounting

STEP 1

Assemble the Post Bracket and the Push-to-Open Bracket

- ◆ Insert the bolts through the holes of post bracket and push-to-open bracket, and fasten with washer and nut as shown.
- ◆ DO NOT over tighten the nut because the post bracket may need to be adjusted later.

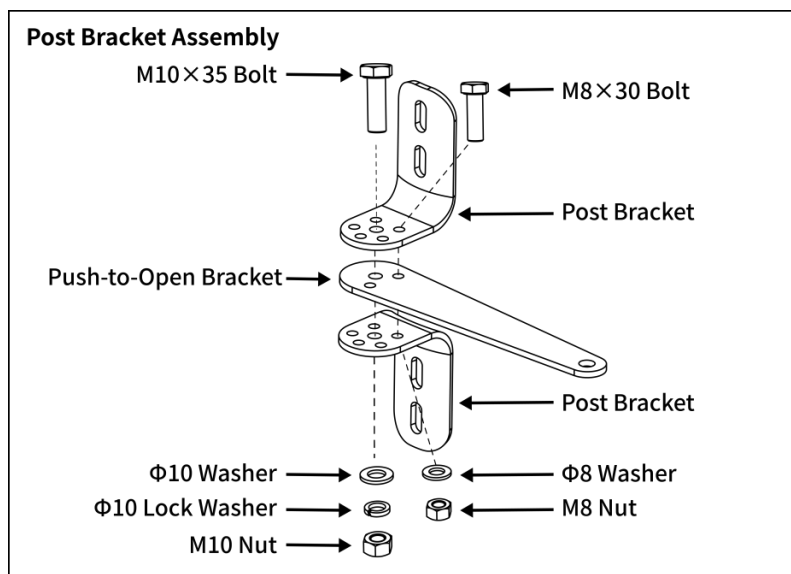

STEP 2

Determine the Position of the Post Bracket Assembly

- ◆ The table shows the maximum opening angle of the gate based on the dimensions of A and B. For example, if A is 15cm (5.9") and B is 12cm (4.7"), the maximum opening angle of the gate is 110°.
- ◆ Measure the dimension of A and B to determine the desired gate opening angle, and then mark the center of the mounting locations for the post bracket accordingly.
- ◆ **Push-to-Open Installation** — Gate in closed position with the moving rod fully retracted.

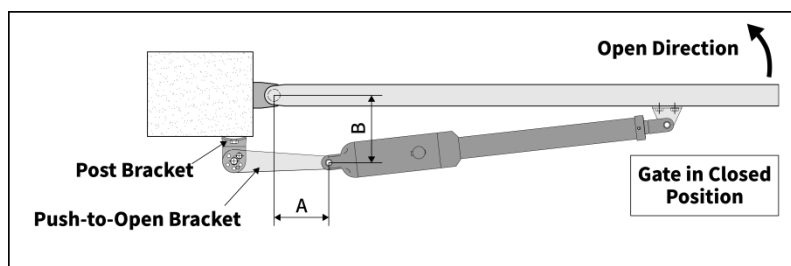

B \ A	15cm (5.9")	13cm (5.1")	11cm (4.3")	9cm (3.5")
10cm (3.9")	112°	105°	95°	86°
12cm (4.7")	110°	103°	95°	86°
14cm (5.5")	107°	101°	95°	86°
16cm (6.3")	105°	100°	94°	86°
18cm (7.1")	104°	99°	93°	86°
20cm (7.9")	103°	98°	93°	86°
22cm (8.7")	103°	97°	92°	87°
24cm (9.4")	95°	97°	92°	87°
26cm (10.2")	88°	96°	92°	87°
28cm (11")	82°	91°	91°	87°



Push-to-Open Gate Opener Mounting

STEP 3

Attach the Brackets to the Gate Opener Arm

- ◆ Attach the post bracket assembly and the gate bracket to the arm by inserting a clevis pin.
- ◆ Secure the clevis pin using the hairpin clip.

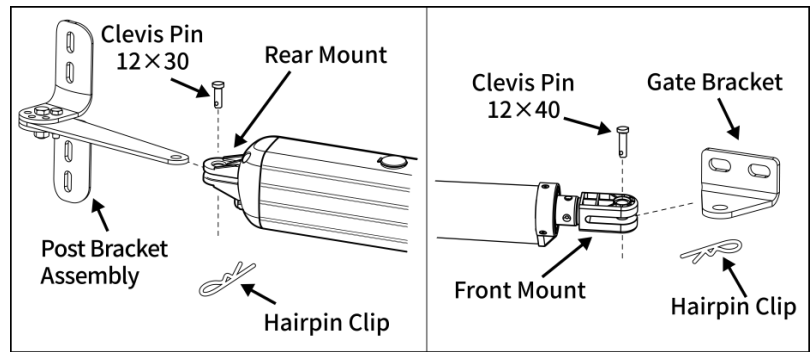

STEP 4

Release the Clutch

- ◆ Open the release hole plug on the top of the gate opener.
- ◆ Insert the manual release key, and turn it 90° clockwise.
- ◆ The gate opener is now in manual mode, allowing for manual extension and retraction of the moving rod.

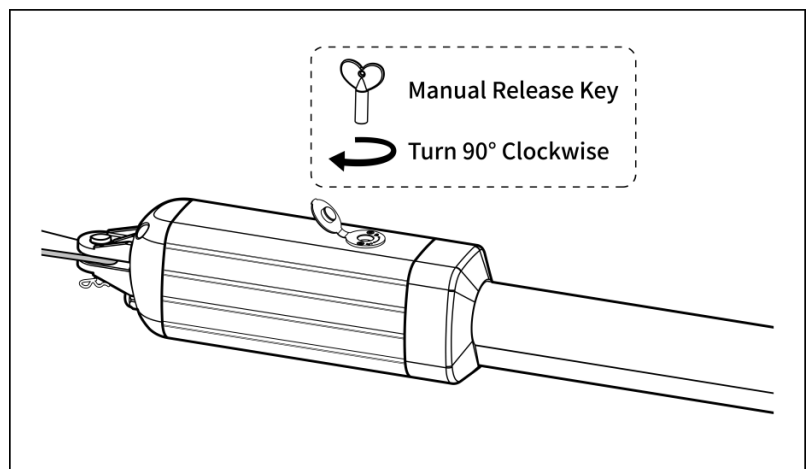

STEP 5

Position the Gate Opener on the Gate

- ◆ Clamp the gate opener arm along with the post bracket assembly to the marked position on the gate post.
- ◆ Make sure that the gate opener is fully retracted and the gate is fully closed to the desired position.
- ◆ Put a level on the arm, then use a C-clamp to secure the gate bracket onto the gate when the arm is level.

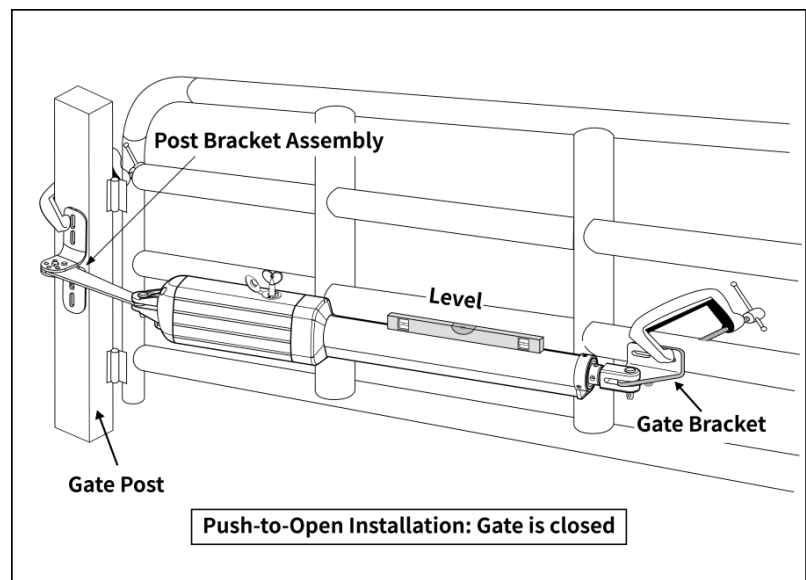



Push-to-Open Gate Opener Mounting

STEP 6

Test Gate Travel and Mark the Brackets Mounting Locations

- ◆ Manually open and close the gate to ensure that the gate bracket position is correct.
- ◆ Ensure that there is a minimum clearance of 2.5cm (1") between the gate and the opener.
- ◆ Make sure that the gate opener does not bind against the push-to-open bracket.
- ◆ If the clearance is less than 2.5cm (1"), or if the gate opener and the push-to-open bracket are binding, rotate the push-to-open bracket and/or move the post bracket assembly.
- ◆ Mark the center of the mounting locations for the brackets.

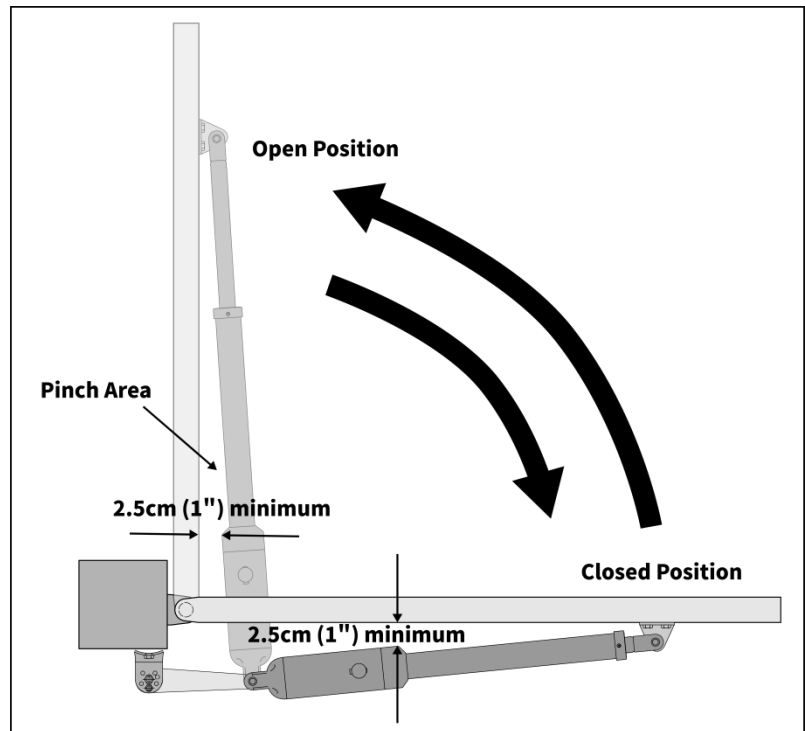

NOTE: This step is very important for determining the position of the gate opener arm and the gate opening angle. It is highly recommended to watch our step-by-step installation video on YouTube for guidance.

STEP 7

Drill Bracket Mounting Holes

- ◆ Remove the C-clamps and the gate opener arm.
- ◆ Drill 10.5mm (0.4") diameter holes through the post and the gate at the marked locations.

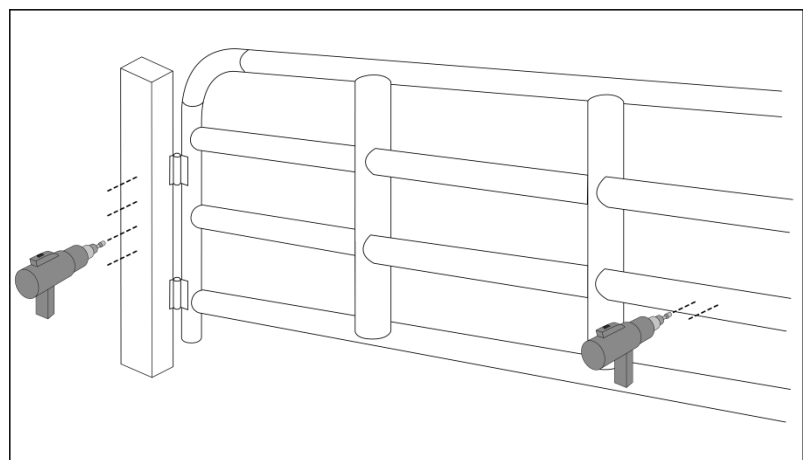



Push-to-Open Gate Opener Mounting

STEP 8

Secure the Post Bracket

- ◆ Secure the post bracket assembly to the gate post by inserting M10 x 200 bolts through the post bracket assembly and the drilled holes in the gate post.
- ◆ Tighten each bolt using one ϕ 10 washer, one ϕ 10 lock washer, and one ϕ 10 nut. Cut off the bolts that extend beyond the tightened nuts.

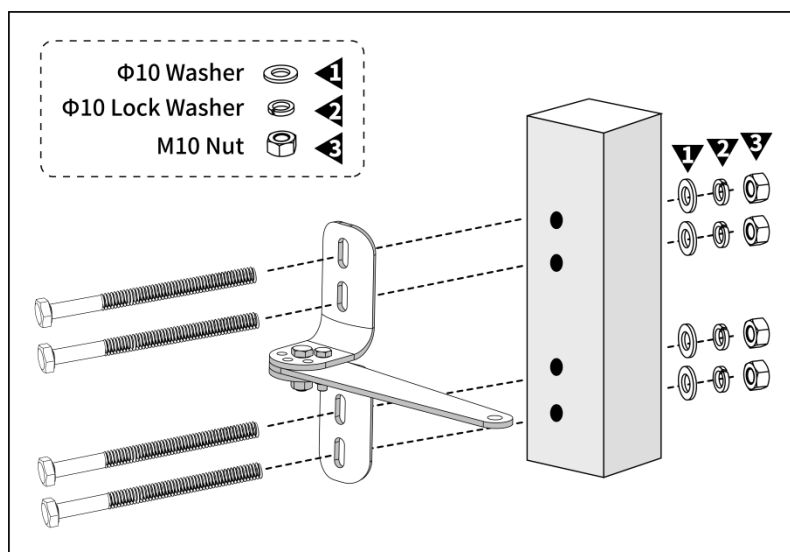

STEP 9

Secure the Gate Bracket

- ◆ Secure the gate bracket to the gate by inserting two M10 x 75 bolts through the gate bracket and the drilled holes in the gate.
- ◆ Tighten each bolt using one ϕ 10 washer, one ϕ 10 lock washer, and one ϕ 10 nut. Cut off the bolts that extend beyond the tightened nuts.

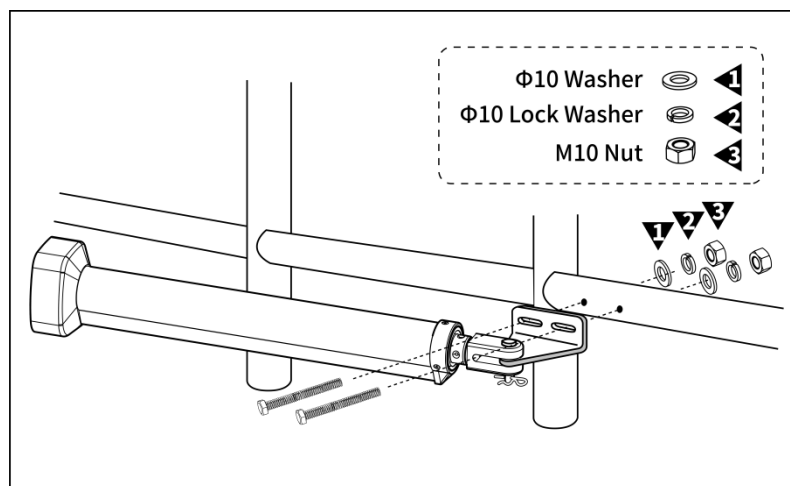

STEP 10

Turn Back the Clutch

- ◆ Manually move the gate to verify that if the installation is appropriate.
- ◆ Turn the release key 90° counterclockwise.

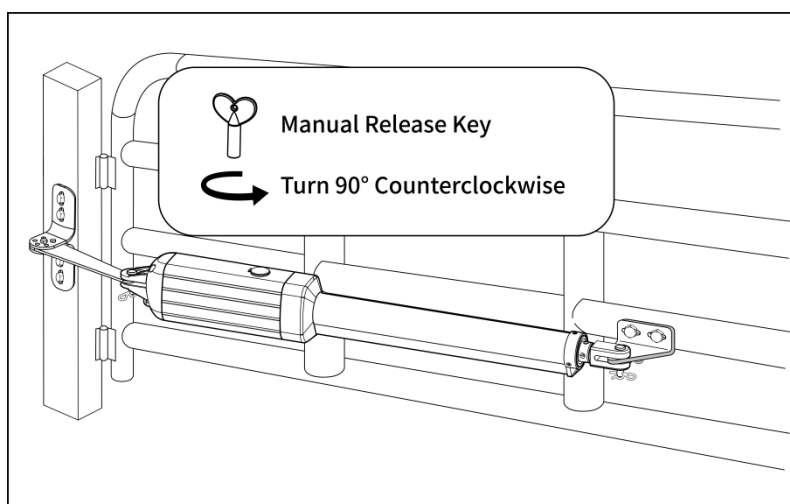

NOTE: Please ensure that the PULL/PUSH TO OPEN setting on the control board matches the installation type.

Mount Control Box

STEP 1

- ◆ Identify a suitable mounting location for the control box at least 1m (3.3ft.) above the ground and no more than 10m (33ft.) from the gate opener arm to prevent it from being flooded or buried under snow.

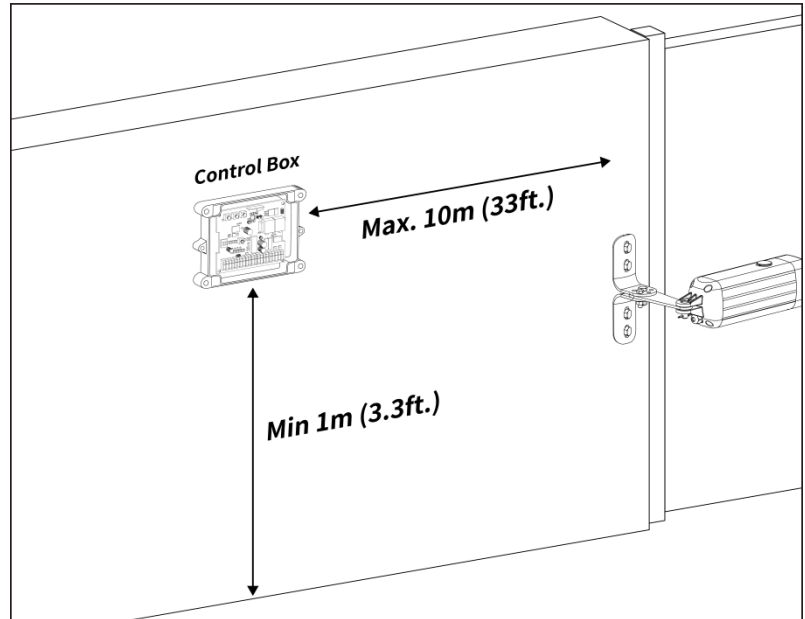

STEP 2

- ◆ Secure the control box using deck screws (NOT included).
- ◆ Use expansion tubes (NOT included) if mounting to a wall.

CAUTION: Make sure that the cable outlet hole is facing downward for proper drainage.

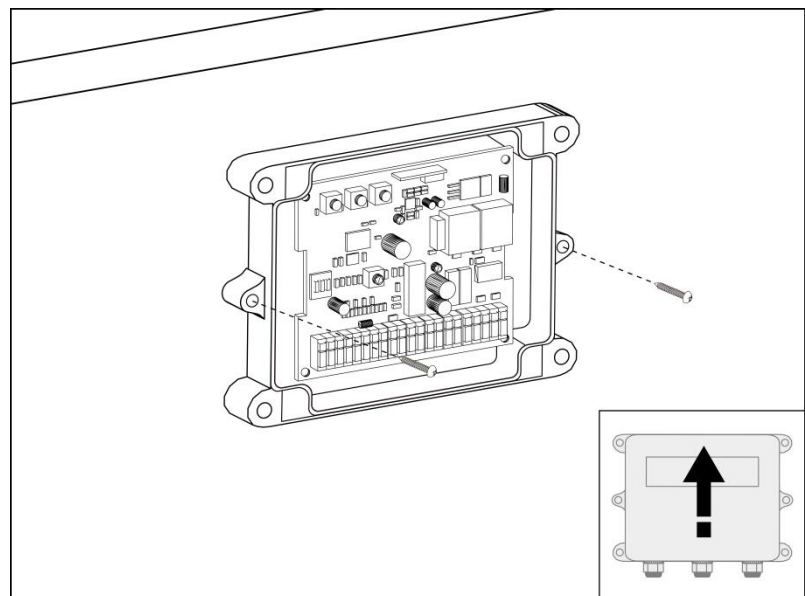

Terminal Function of the Control Board

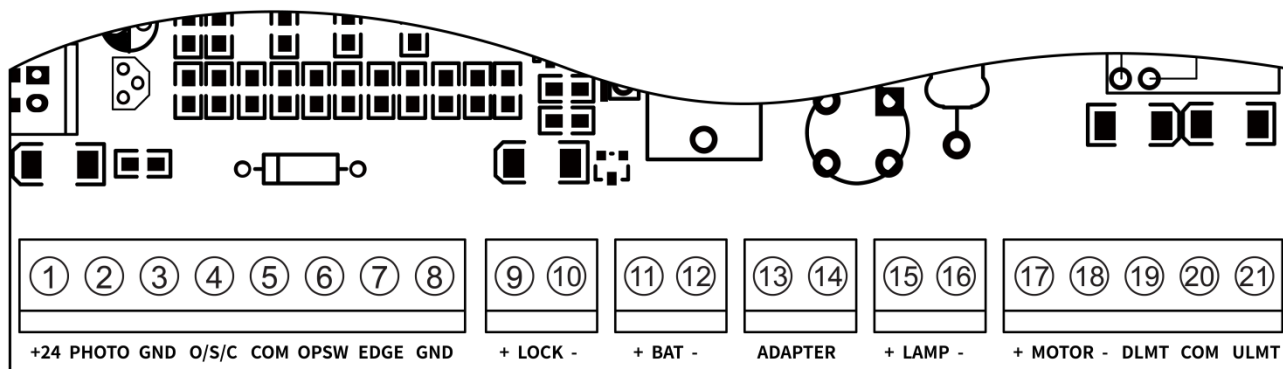

Terminal	Function
① “+24” ③ “GND”	Provide 24VDC voltage output to power photocell sensors
② “PHOTO” ③ “GND”	Receive signal input from a photocell sensor, operating on a normally closed (NC) input basis
④ “O/S/C” ⑤ “COM”	Control gate operation through a normally open dry contact signal input, commonly connected to push button, wired keypad, and external receiver for cyclic gate operation (open/stop/close/stop)
⑥ “OPSW” ⑤ “COM”	Accept the signal input of the gate opening, usually connected to the normally open output of a vehicle sensor
⑦ “EDGE” ⑧ “GND”	Receive signal input from an edge sensor, operating on a normally open input basis
⑨⑩ “+LOCK-”	Output terminals for swing gate electric lock, directly connected to the positive and negative wires of the lock. Ensure the lock is a fail secure type with a rated voltage of 24VDC and a rated current of less than 3A
⑪⑫ “+BAT-”	Input terminals for 24VDC power, typically connected to the positive and negative terminals of a 24VDC battery or 24VDC power supply, providing power to the entire system or other 24VDC accessories
⑬⑭ “ADAPTER”	Input terminals for a power adapter to charge the battery, can also be connected to a 36VDC or 24VAC power supply for battery charging
⑮⑯ “+LAMP-”	Output terminals for a warning light, connected to the positive and negative wires of the warning light. Ensure that the warning light has a rated voltage of 24VDC and a rated current of less than 1A
⑰⑱ “+MOTOR-”	Connect to the red and black wires of the gate opener arm
⑲ “DLMT” ⑳ “COM” ㉑ “ULMT”	Input terminals for limit switches, the near end limit switch connected to “DLMT” and “COM”, the far end limit switch connected to “ULMT” and “COM”

NOTE: For terminal wiring, remove the terminal from the control board and unscrew the terminal screws using a screwdriver. Insert the wire into the terminal, tighten the screws to secure the wire, and then reattach the terminal to the control board.

Connect the Arm to the Control Board

NOTE

- ◆ *It is highly recommended to watch our step-by-step installation video on YouTube for wire connection.*

- ◆ Insert the wire harness through the cable gland into the control box.
- ◆ Connect the red wire into terminal ⑰ “+MOTOR1”, the black wire into terminal ⑱ “MOTOR1-”, the blue wire into terminal ⑲ “DLMT”, the green wire into terminal ⑳ “COM”, and the yellow wire into terminal ㉑ “ULMT” .
- ◆ Tighten each of the screws so that the wires do not come loose and fall out.

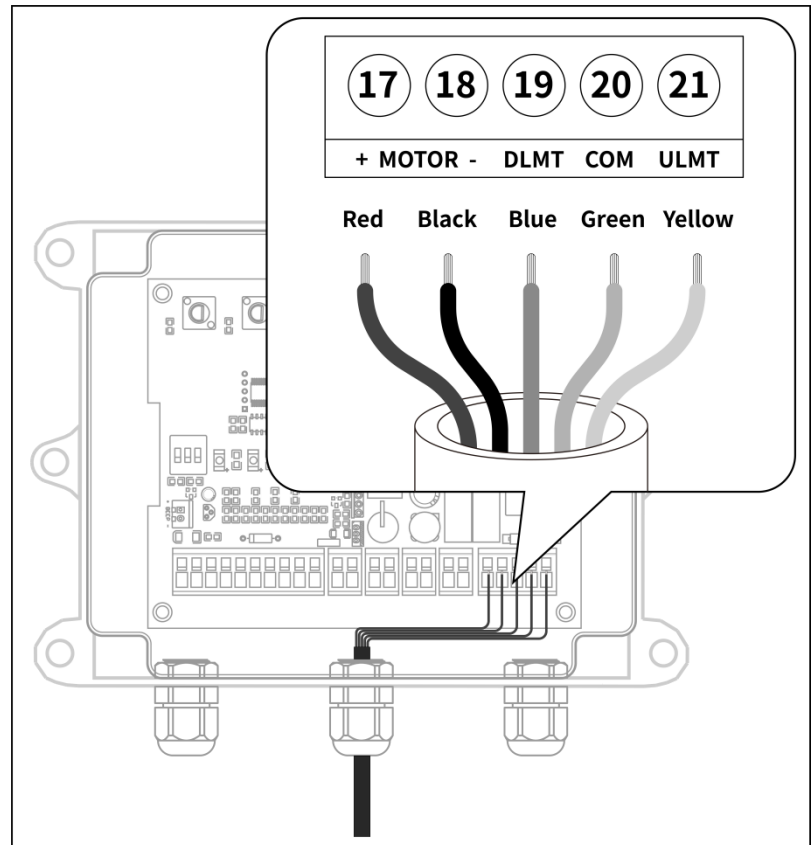

Connection of Power Supply

WARNING

- ◆ A professional electrician is required for wire connection to avoid the risk of injury, electric shock, or death. NEVER connect the gate opener to the electrical outlet before all the installations have been done.
- ◆ It is recommended to use a surge protector with a rated current of 5A with the TS24-U adapter or power supply (sold separately). Protect the electrical outlet with a weatherproof cover if it is located outdoors.

Power Mode 1

By the Adapter and Batteries

- ◆ Connect the TS24-U adapter to the “ADAPTER” terminals of the control board, regardless of the polarity of the wires.
- ◆ Connect two 12VDC batteries in series to achieve 24VDC (batteries not included).
- ◆ Connect the batteries to the “+BAT-” terminals of the control board.
- ◆ Plug the TS24-U adapter into an electrical outlet.

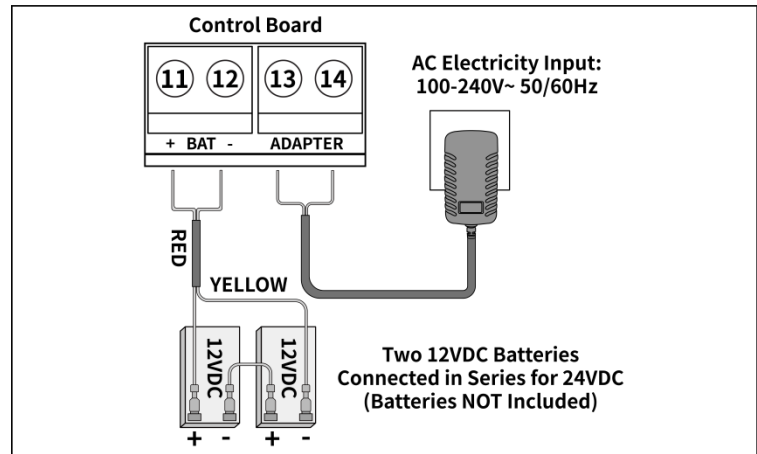

IMPORTANT NOTES

- ◆ The adapter is ONLY used to charge the battery. The length of the adapter output cable is 1.2m (4ft.). To extend the cable, the cable should be at least $2C \times 1.3 \text{ mm}^2$ (16AWG). If the distance between the control board and the adapter is more than 100m (330ft.), the cable should be at least $2C \times 2 \text{ mm}^2$ (14AWG). The maximum extension distance is 300m (1000ft.).
- ◆ If the gate opener is powered by batteries and utilizes AC electricity for charging, a minimum of a 24VDC 7Ah automotive / marine type battery is required.

Power Mode 2

Use AC Electricity Only

- ◆ Connect the male terminals from the output wires of the DPS180-U AC-DC power supply (sold separately) to the female terminals of the power input wires connected to the “+BAT-” terminals of the control board.
- ◆ Plug the DPS180-U power cord into an electrical outlet.

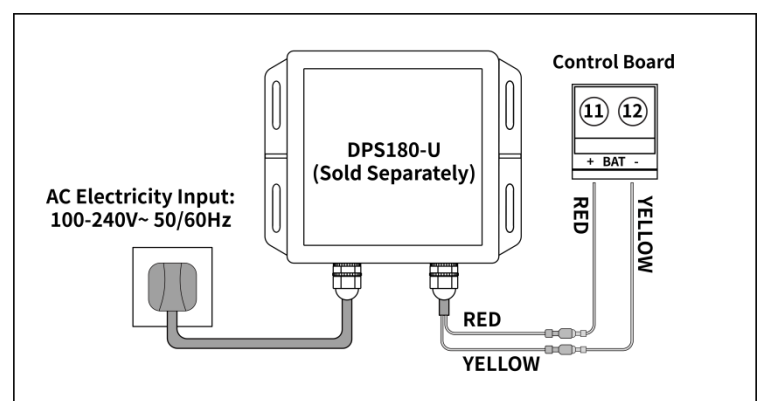

IMPORTANT NOTE

- ◆ The DPS180-U power supply can NOT connect with batteries or solar panels.

Connection of Power Supply

Power Mode 3

By the Adapter, Solar Panels and Batteries

- ◆ Connect the BAT wires of the TCS3 solar charge controller to the “+BAT-” terminals of the control board.
- ◆ Tape the LOAD wires of the TCS3 solar controller to prevent a short circuit.
- ◆ Connect two 12VDC batteries in series to achieve 24VDC (batteries not included).
- ◆ Connect the batteries to the “+BAT-” terminals of the control board.
- ◆ Assemble the solar panels and connect the solar panels in parallel and mount in an area clear of all obstructions and shading from buildings and trees. The solar panel should face south if it is located north of the equator. If it is located south of the equator, it should face north.
- ◆ Connect the SOLAR wires of the TCS3 solar controller to the solar panels.
- ◆ Connect the TS24-U adapter to the “ADAPTER” terminals of the control board, regardless of the polarity of the wires.
- ◆ Plug the TS24-U adapter into an electrical outlet.

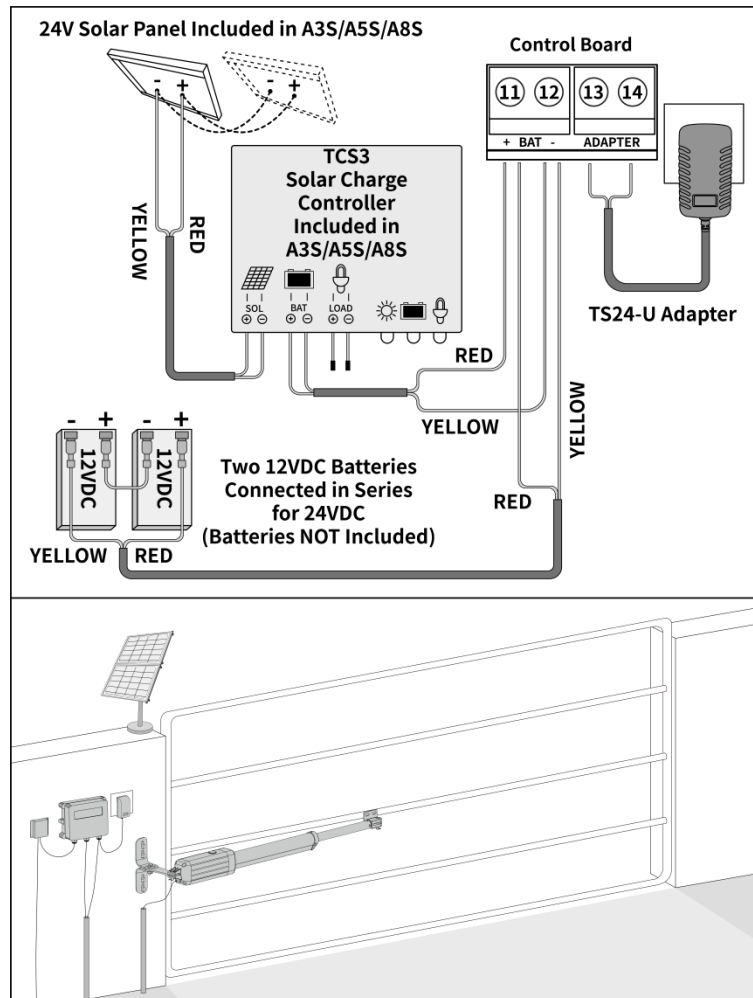

IMPORTANT NOTES

- ◆ The batteries should be waterproof, or they should be placed in waterproof housing.
- ◆ The adapter is ONLY used to charge the battery. The length of the adapter output cable is 1.2m (4ft.). To extend the cable, the cable should be at least 2C x 1.3 mm² (16AWG). If the distance between the control board and the adapter is more than 100m (330ft.), the cable should be at least 2C x 2 mm² (14AWG). The maximum extension distance is 300m (1000ft.).
- ◆ The TCS3 solar charge controller supports a maximum solar panel power of 240W, exceeding this limit can cause damage to it.
- ◆ If the gate opener is powered by batteries and utilizes both AC electricity and solar panel for charging, a minimum of a 24VDC 7Ah automotive / marine type battery and a 24V 20W solar panel are required.

Connection of Power Supply

Power Mode 4

By Solar Panels and Batteries

- ◆ Connect the LOAD wires of the TCS3 solar charge controller to the “+BAT-” terminals of the control board.
- ◆ Connect two 12VDC batteries in series to achieve 24VDC (batteries not included).
- ◆ Connect the BAT wires of the TCS3 solar controller to the batteries.
- ◆ Assemble the solar panels and connect the solar panels in parallel and mount in an area clear of all obstructions and shading from buildings and trees. The solar panel should face south if it is located north of the equator. If it is located south of the equator, it should face north.
- ◆ Connect the SOLAR wires of the TCS3 solar controller to the solar panels.

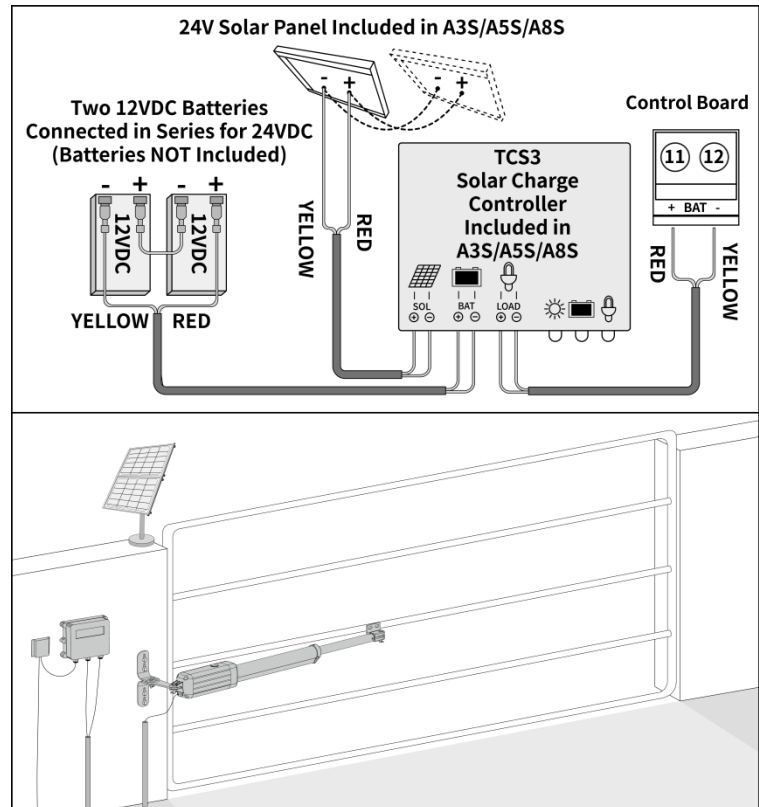

IMPORTANT NOTES

- ◆ *The batteries should be waterproof, or they should be placed in waterproof housing.*
- ◆ *The TCS3 Solar Charge Controller supports a maximum solar panel power of 240W, exceeding this limit can cause damage to it.*
- ◆ *If the system is only powered by battery and utilizes the solar panel for charging, a minimum of a 24VDC 12Ah automotive/marine type battery and a 24V 20W solar panel are required.*
- ◆ *If there are more than 6 hours of sunlight per day and no accessories are connected (except for the photocell sensor, electric lock, push button, and warning light), the gate opener can operate 10 cycles per day.*
- ◆ *Add more solar panels and increase battery capacity if there is less than 6 hours of sunlight per day or if using any accessories (such as an external receiver, exit wand, or wired keypad).*
- ◆ *For precise recommendations on solar panel power and battery capacity, please contact our customer support at www.topens.com.*

Connection of Power Supply

Power Mode 5

By AC Electricity, Solar Panels and Back-up Batteries

- ◆ Connect the male terminals from the LOAD output wires of the UPS01 power supply (sold separately) to the female terminals of the power input wires connected to the “+BAT-” terminals of the control board.
- ◆ Connect two 12VDC batteries in series to achieve 24VDC (batteries not included).
- ◆ Connect the BAT wires of the UPS01 power supply to the batteries.
- ◆ Assemble the solar panels and connect the solar panels in parallel and mount in an area clear of all obstructions and shading from buildings and trees. The solar panel should face south if it is located north of the equator. If it is located south of the equator, it should face north.
- ◆ Connect the SOLAR wires of the UPS01 power supply to the solar panels.
- ◆ Plug the UPS01 power cord into an electrical outlet.

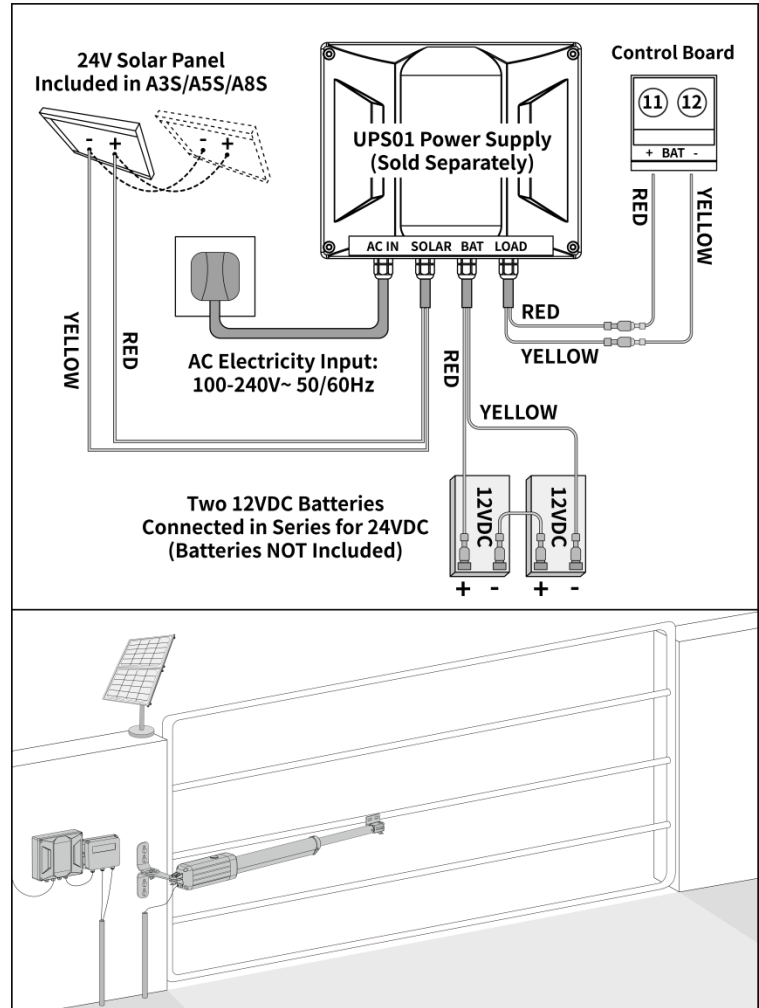

NOTE ABOUT THE BATTERY AND SOLAR PANEL

- ◆ *The batteries should be waterproof, or they should be placed in waterproof housing.*
- ◆ *The UPS01 power supply supports a maximum solar panel power of 240W, exceeding this limit can cause damage to the UPS01 power supply.*
- ◆ *If AC power failures occur for less than 8 hours per day, you can use a minimum of 24VDC 5Ah automotive/marine type battery and a 24V 10W solar panel as a backup power source.*

Program the Remote Control

NOTE

- ◆ *Keep the gate movement area free of obstructions, and ensure children, pets and livestock stay away from the gate opener system while the gate is in motion.*
- ◆ *If you lose any remote control, please erase and reprogram all remaining remote controls for safety.*

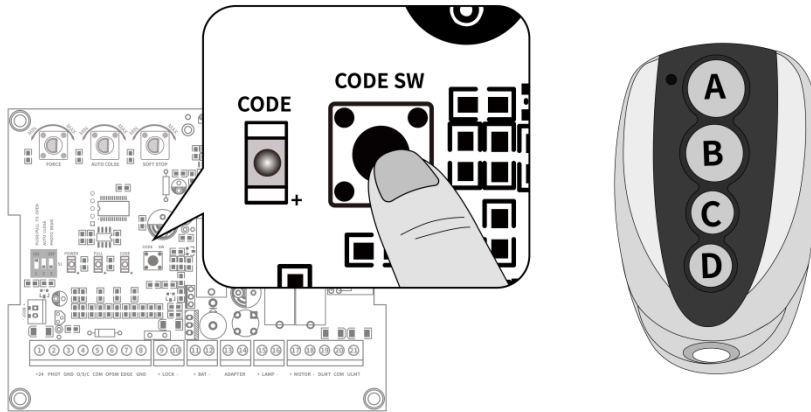

Function of the Remote Control Button

- ◆ Each remote has four buttons, from top to bottom are separately A, B, C and D.
- ◆ For the swing gate opener, all four buttons share the same function. You can use any of these buttons to program with the gate opener.
- ◆ Each press of the programmed button will cycle the gate through open, stop, close, stop, and open.

How to Program the Remote Control

The remote control **MUST** be programmed to the gate opener before use. The remote controls that come with the gate opener are preprogrammed.

If you purchase additional remote controls, or if the programmed remotes are not working, repeat the programming steps below for each remote control.

Enter Programming Mode

- ◆ Press and release the CODE SW button on the control board. The CODE LED will turn on, indicating that the gate opener is now in programming mode.

Program the Remote Control

- ◆ Press the remote control button you want to program once, then press it again after the LED on the remote turns off.
- ◆ The CODE LED will flash for 3 seconds and then turn off, indicating successful programming.

Additional Remote Controls

- ◆ The gate opener can pair Max. 8 M12 remote controls on its own, and up to 250 with the ERM12 External Receiver (sold separately on the TOPENS website www.topens.com).

How to Erase All Programmed Remote Controls

- ◆ Press and hold the CODE SW button until the CODE LED turns from ON to OFF. Now all programmed remote controls have been erased.

Adjust the Limit Switch

NOTE

- ◆ The position of Limit Switch A has been fixed at the factory, do not adjust it.
- ◆ The limit switches are located underneath the arm. Turn the arm over to access the limit switch screws. Once the adjustment is completed, remember to turn the arm back to its correct position.

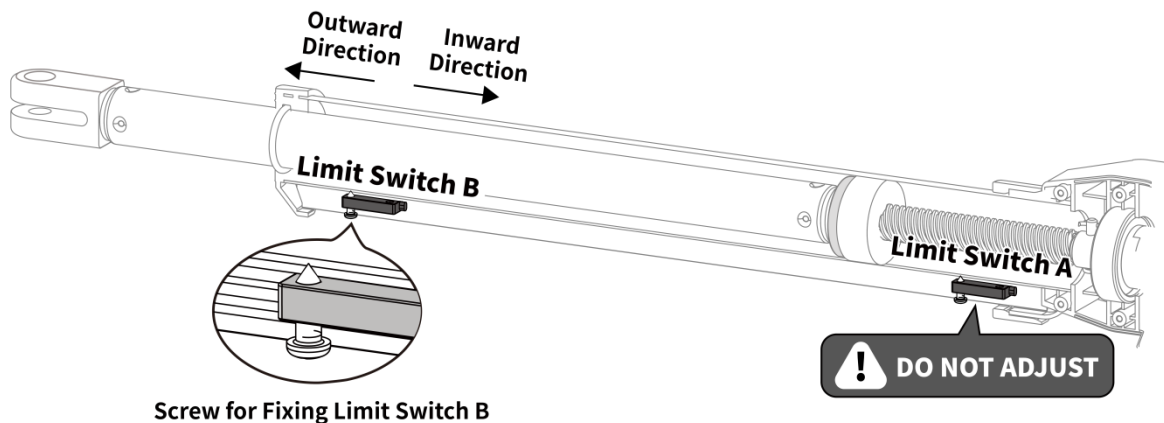

For Pull-to-Open Installation

Adjust the Limit Switch B to Determine the Closed Position

- ◆ Make sure that the moving rod is fully retracted when the gate is in the fully open position before adjusting the limit switch.
- ◆ Turn on power to operate the gate opener, the arm will extend to close the gate.
- ◆ If the gate closes over the desired closed position, press the remote control to stop the gate opener. Use a screwdriver to loosen the screw of the limit B, slightly slide the limit switch B inwards.
- ◆ If the gate closes halfway and fails to get to the desired closed position, slightly slide the limit switch B outwards.
- ◆ Please repeat the above steps until the gate reaches and automatically stops at the desired closed position. Then tighten the screw firmly.

For Push-to-Open Installation

Adjust the Limit Switch B to Determine the Open Position

- ◆ Make sure that the moving rod is fully retracted when the gate is in the fully closed position before adjusting the limit switch.
- ◆ Turn on power to operate the gate opener, the arm will extend to open the gate.
- ◆ If the gate opens over the desired open position, press the remote control to stop the gate opener. Use a screwdriver to loosen the screw of the limit B, slightly slide the limit switch B inwards.
- ◆ If the gate opens halfway and fails to get to the desired open position, slightly slide the limit switch B outwards.
- ◆ Please repeat the above steps until the gate reaches and automatically stops at the desired open position. Then tighten the screw firmly.

Setting of the Control Board

WARNING

- ◆ Ensure that the gate opener is powered off when making any adjustments.
- ◆ Keep away from the gate while setting up the gate opener system to avoid unexpected gate movement.
- ◆ Carefully adjust the DIP switches to prevent the risk of damaging the gate opener and causing injury or death.
- ◆ Always seek assistance from a professional technician or electrician if you have any questions.

DIP Switches

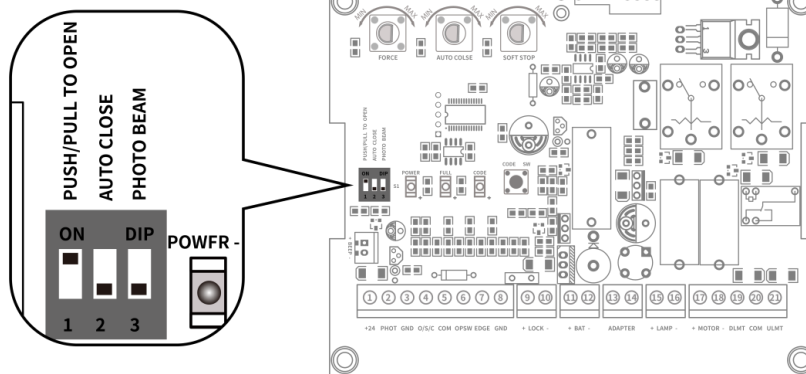

DIP Switch #1: Set Pull/Push-to-Open

ON – Push-to-Open

OFF – Pull-to-Open

The factory default setting is **OFF**.

If the gate opens into the property (Pull-to-Open), set the DIP Switch to **OFF**.

If the gate opens out from the property (Push-to-Open), set the DIP Switch to **ON**.

DIP Switch #2: Enable/Disable Auto Close Function

ON – Auto close function enabled

OFF – Auto close function disabled

The factory default setting is **OFF**. The auto close function allows the gate to automatically close after a set period.

IMPORTANT NOTES:

- ◆ The auto close function should be enabled if a vehicle sensor exit wand is installed.
- ◆ When the auto close function is enabled, the photocell sensor is highly recommended to be installed with the gate opener for safety.
- ◆ The auto close time can be adjusted by turning the AUTO CLOSE Potentiometer.

DIP Switch #3: Enable/Disable Photocell Sensor Function

ON – Photocell sensor function enabled

OFF – Photocell sensor function disabled

The factory default setting is **OFF**.

Set the switch #3 to **ON** to enable the photocell sensor function if you want to use the photocell sensor with the gate opener.

Setting of the Control Board

Potentiometers

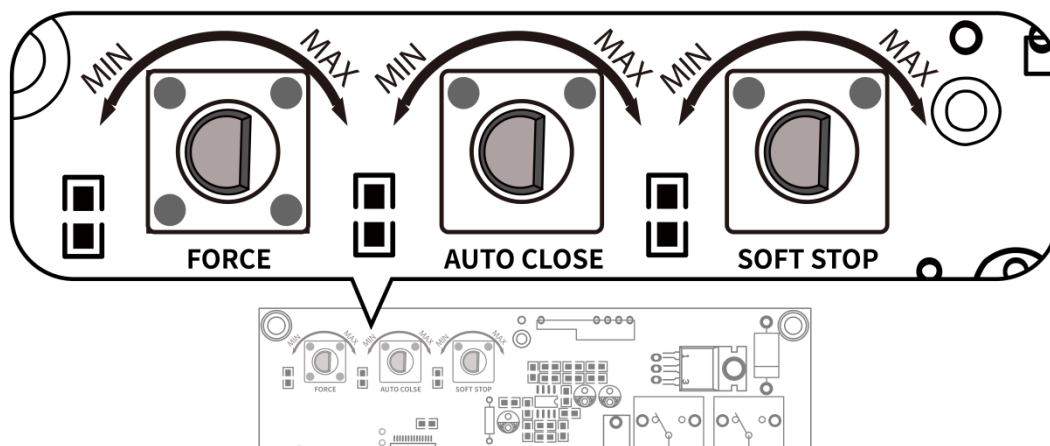

FORCE Potentiometer: Adjust the Stall Force of the Gate Opener

- ◆ Turn the potentiometer clockwise to increase the force, and counterclockwise to decrease it.
- ◆ Stall force regulates the gate's sensitivity to obstacles during operation. A higher stall force decreases sensitivity, making the gate less likely to detect objects. A lower stall force increases sensitivity, causing the gate to stop or reverse when encountering even minor obstructions.

AUTO CLOSE Potentiometer: Adjust the Auto Close Time of the Gate Opener

- ◆ Turn the potentiometer clockwise to increase the auto close time, and counterclockwise to decrease it. The auto close time can be adjusted from 3 to 120 seconds.

SOFT STOP Potentiometer: Adjust the Soft Stop Period of the Gate Opener

- ◆ Turn the potentiometer clockwise to increase the soft stop period, and counterclockwise to decrease it. The soft stop period can be adjusted from 1 to 5 seconds.
- ◆ The soft stop is designed to slow down the gate during the final phase before it fully stops, protecting the motor.
- ◆ Turn off the power to the gate opener before making adjustment. After adjusting, turn on the power and use the remote control to run a complete open and close cycle to calibrate the full open and close times. This will ensure the adjustment is effective in subsequent cycles.

Stall Force Adjustment & Obstruction Test

Fine Tune the Stall Force

This force should be high enough to ensure the gate reaches both the open and close limits without reversing unnecessarily or causing frequent interruptions, but low enough to prevent injury if an obstruction is encountered. The appropriate stall force setting will depend on the gate's length and weight, so fine-tuning may be required. Follow these steps to adjust the stall force:

- ◆ **Initial Assessment:** Use the remote control to open and close the gate and observe its movement.
- ◆ **Adjust the Stall Force:** If the gate reverses before reaching the fully close position or stops before reaching the fully open position, increase the stall force by turning the FORCE Potentiometer slightly clockwise.
- ◆ **Perform the Obstruction Test:** Run the test after every force setting adjustment (see below).

Obstruction Test

This test ensures that the gate opener's automatic obstruction sensing feature is functioning correctly. The gate should have enough force to reach both the open and close limits, but it **MUST** reverse when encountering a solid object during closing and stop during opening.

- ◆ **Operate the Gate:** Open and close the gate with the remote control, ensuring that the gate stops at the proper open and close limit positions.
- ◆ **Setup for the Test:** Place a solid, immovable object in the gate's path to simulate an obstruction.
- ◆ **Test Gate Closure and Opening:** Run the gate in the closing direction towards the obstruction and conduct the same test with the gate moving in the opening direction.
- ◆ **Adjust Force if Necessary:** The gate should reverse when it encounters the obstruction during closing and stop during opening. If the gate does not reverse or stop, reduce the force by turning the FORCE Potentiometer slightly counterclockwise.

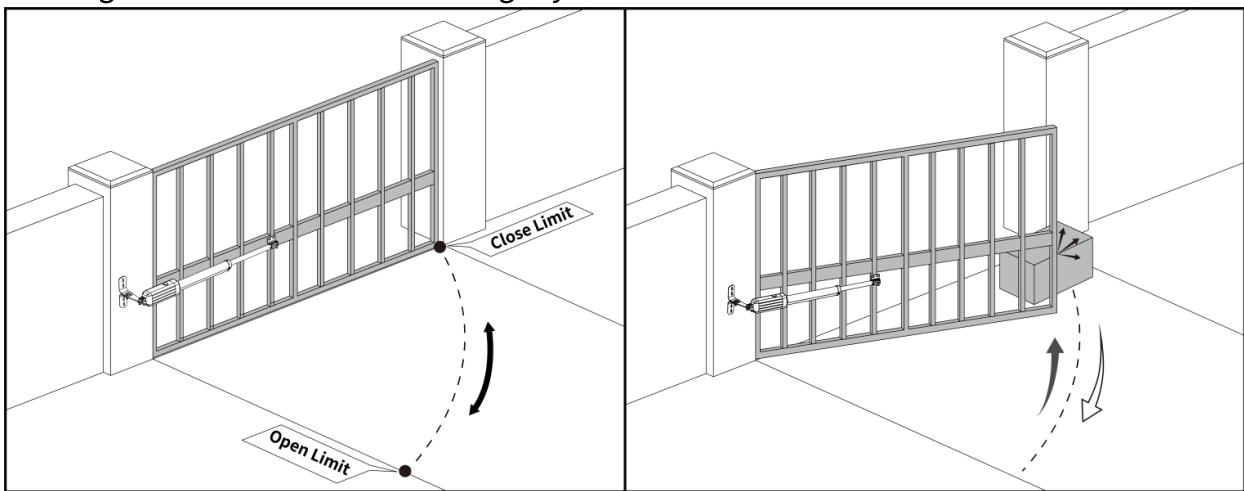

NOTES:

- ◆ *If the stall force is set too low (i.e., the sensitivity is too high), the gate may stop or reverse too easily, even with minimal obstruction or resistance, such as strong wind or heavy snow.*
- ◆ *Always perform an obstruction test for the gate each time you set up the control board or restart it after a power outage.*
- ◆ *The gate opener is designed to reverse the gate when the gate comes in contact with an obstruction during closing and to stop the gate during opening. It is highly recommended to install a photocell sensor for additional safety.*

Connection of Accessories

NOTE

- ◆ This section covers only the programming and wire connections with the control board. For additional operations, please refer to the corresponding accessory user manual.
- ◆ It is highly recommended to install a photocell sensor in the following situations for safety: if you have children or pets at your property, the gate opener auto close function is set to ON, the gate opener stall force is set to the maximum, a vehicle exit sensor is installed, or other gate control devices are used.

TC188 Universal Keypad

Operate the gate using a user-defined password. You can use this keypad wirelessly or wire it to the gate opener according to your needs.

Wireless Mode Programming and Operation

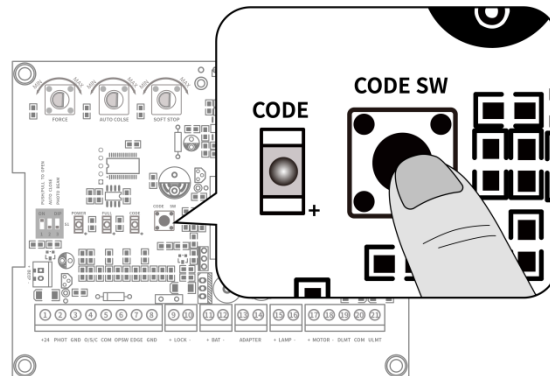
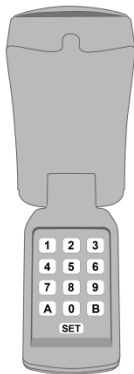

Step 1 Program New Master Code

Factory default master code is 9999, all codes should be 4 digits in length.

SET 4 digits Old Master Code SET 01 SET 4 digits New Master Code SET 4 digits New Master Code SET

Step 2 Add New Permanent Entry Code

SET Master Code SET 02 SET Entry Code SET Entry Code SET

Step 3 Program with the Gate Opener

- ◆ Input the entry code of the keypad.
- ◆ Press and release the CODE SW button on the control board. The CODE LED will turn on, indicating that the gate opener is now in programming mode.
- ◆ Press button A (or B) once, and the keypad LED backlight will flash quickly. Press it again after the backlight changes from a rapid flash to a slow flash.
- ◆ The CODE LED will flash for 3 seconds and then turn off, indicating successful programming.

Step 4 Operate the Gate Opener

Input the entry code and then press the programmed button A (or B) to operate the gate. Within 3 seconds of pressing button A (or B), you can press the button again without re-entering the code to operate the gate.

Connection of Accessories

Wired Mode Connection and Operation

Step 1 Remove the Battery

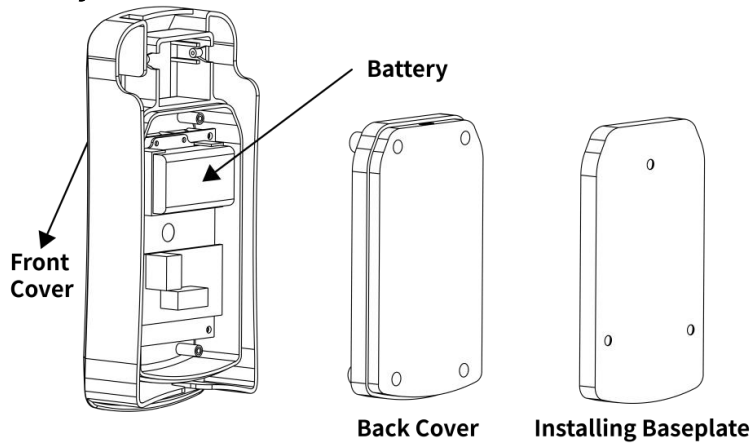

Step 2 Wire Connection

Connect the “COM” and “NO” terminals to the control board terminal ④ “O/S/C” and terminal ⑤ “COM”. Then connect the “9-24V AC/DC” terminals to the control board terminal ⑤ “COM” and terminal ⑪ “+BAT”. Polarity does not matter for these connections.

NOTE: A 4C x 0.3 mm² (22AWG) cable is required for the wire connection, but it is NOT included.

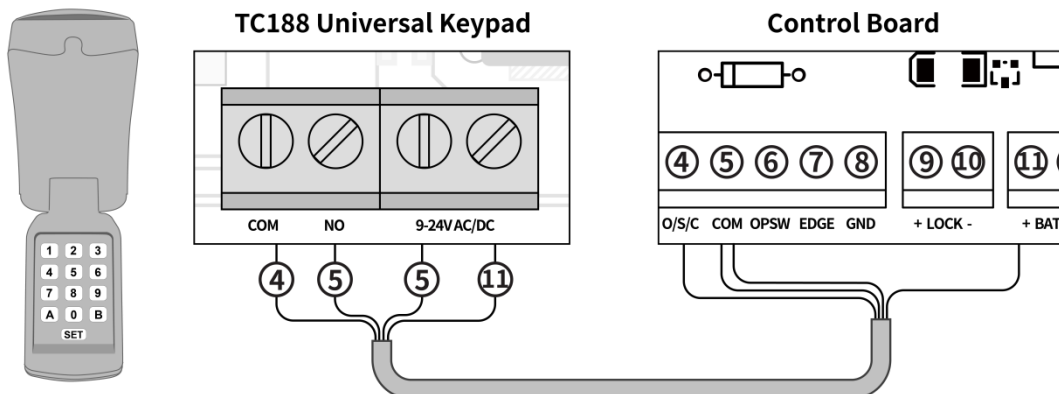

Step 3 Program New Master Code

Factory default master code is 9999, all codes should be 4 digits in length.

SET 4 Digits Old Master Code SET 01 SET 4 Digits New Master Code SET 4 Digits New Master Code SET

Step 4 Add New Permanent Entry Code

SET Master Code SET 02 SET Entry Code SET Entry Code SET

Step 5 Operate the Gate Opener

Input the entry code and then press button A (or B) to operate the gate. Within 3 seconds of pressing button A (or B), you can press the button again without re-entering the code to operate the gate.

NOTE: If the gate opener is ONLY solar powered, please add more solar panels and upgrade the battery capacity to support the additional power consumption by the wired keypad.

Connection of Accessories

TKP3 Wireless Keypad

Operate the gate with a user defined password

Programming and Operation

- ◆ Press and release the CODE SW button on the control board. The CODE LED will turn on, indicating that the gate opener is now in programming mode.
- ◆ Press the button “OK” on the keypad and the CODE LED will flash for 3 seconds and then turn off, indicating successful programming.
- ◆ Use the default password “888888” to operate the gate opener. Press “PIN” “8 8 8 8 8 8” and then press the button “OK” to operate the opener. Just one press of the button “OK” , the moving gate will stop for quick passing through.

Change the Password

- ◆ Press “PIN” and then input the old six digits password and then press “PIN” again, the CODE LED will be ON.
- ◆ Input the new six digits password and then press the “PIN” to confirm the new setting, CODE LED will flash for 3 seconds and then turn off which indicates the password has been changed successfully.
- ◆ Press “PIN” “new six digits password” and then press the button “OK” to operate the gate opener.

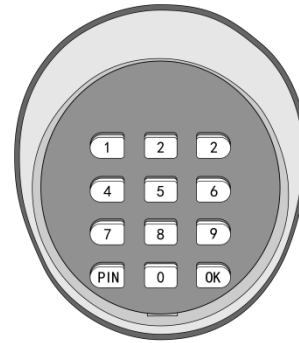

Program the Keypad

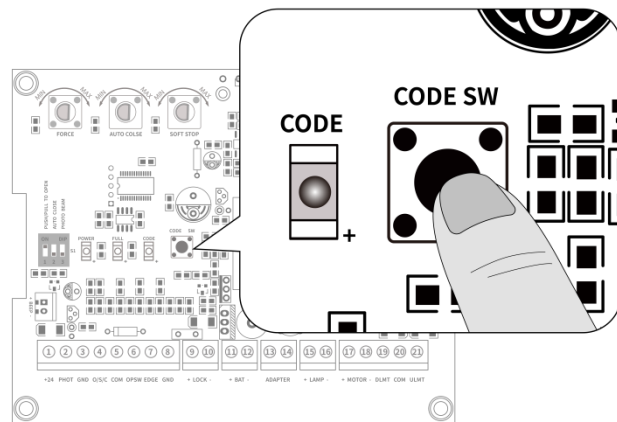

Use the Default Password

PIN 888888 OK

Change the Password

PIN Old Six Digits Password PIN

New Six Digits Password PIN

Use the New Password

PIN New Six Digits Password OK

NOTES:

- ◆ Each button press during programming must be completed within 1 second to ensure successful programming.
- ◆ If you forget the password, you can reset the keypad to restore the default code "888888" by reprogramming it.

Connection of Accessories

TC173 Wireless Push Button

Open/close gate by pressing the wireless button

Programming and Operation

- ◆ Press and release the CODE SW button on the control board. The CODE LED will turn on, indicating that the gate opener is now in programming mode.
- ◆ Press the push button once, then press it again after the LED on the push button turns off. The CODE LED will flash for 3 seconds and then turn off, indicating successful programming.
- ◆ Each press of the button will cycle the gate through open, stop, close, stop, and open.

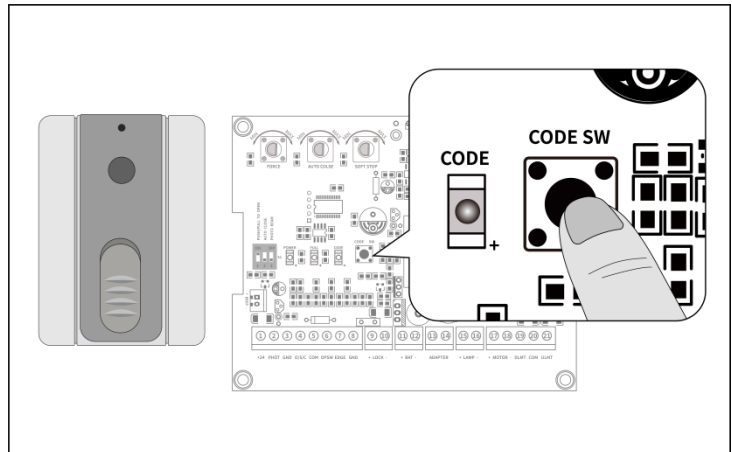

TC196 Tuya WiFi Remote Control

- ◆ Control the gate opener with your cellphone anytime and anywhere when the remote controller is connected with WiFi.
- ◆ Please see detailed connection steps in TC196 user manual.

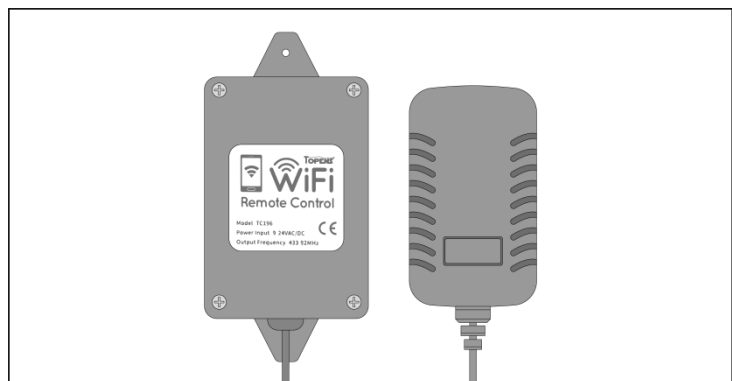

Connection of Accessories

ET24 Electric Gate Lock

Locks and unlocks the gate automatically

Wire Connection

- ◆ Connect the electric lock to the control board terminal ⑨ and ⑩ “+LOCK-”, regardless of the polarity of the wires.

Key Installation Notes

- ◆ For pull to open gate, install the lock on the gate and the receiver on the wall or gate post.
- ◆ For push to open gate, install the lock on the wall or gate post, and the receiver on the gate.
- ◆ The lock and receiver must fit close. Check it when the gates close firmly.
- ◆ Ensure that the lock and receiver are level, aligned with the gate opener arm, and mounted on a tube fence or other solid part of the gate surface.

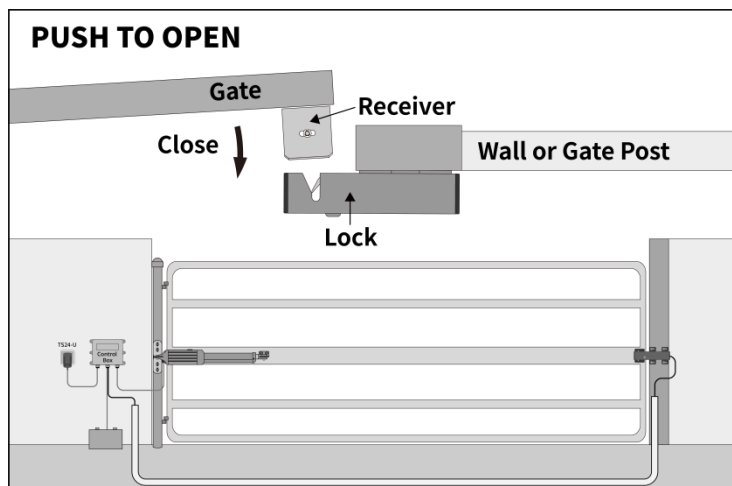
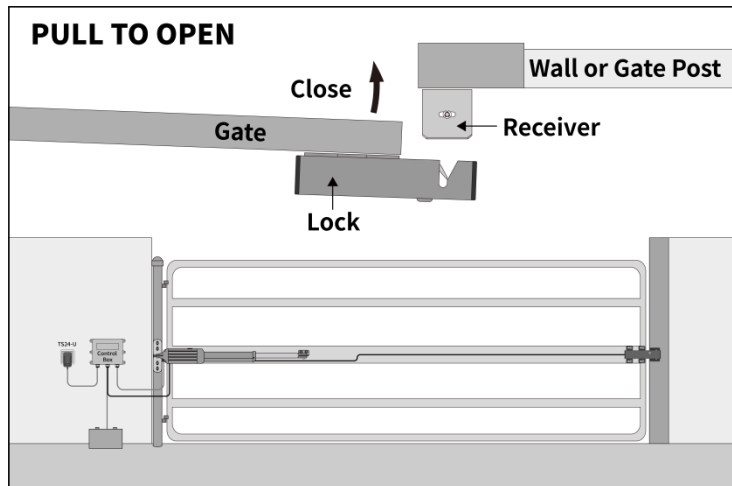
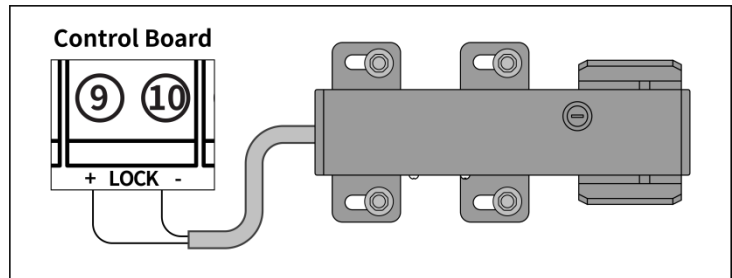

Connection of Accessories

TEW3 Vehicle Sensor Exit Wand

Opens the gate automatically when senses an approaching car

Wire Connection

- ◆ Connect the BLACK wire to the control board terminal ⑤ “COM” .
- ◆ Connect the BLUE wire to the control board terminal ⑥ “OPSW” .
- ◆ Connect the RED wire to the control board terminal ⑪ “BAT+” .
- ◆ Connect the GREEN wire to the control board terminal ⑫ “BAT-” .
- ◆ The sensitivity range adjustment board should be wired to the GREEN wire and the YELLOW wire of the wand, regardless of the polarity of the wires.

Key Installation Notes

- ◆ Install the wand 7.5m to 30m (25ft. to 100ft.) away from the gate, and bury it 5cm (2") deep from ground and 20cm (8") from the driveway edge.
- ◆ Install the wand away from any power lines to avoid interrupting the detection signal.
- ◆ It is strongly recommended to enable the auto close function by referring to the Setting of the Control Board section in this manual to ensure home security.

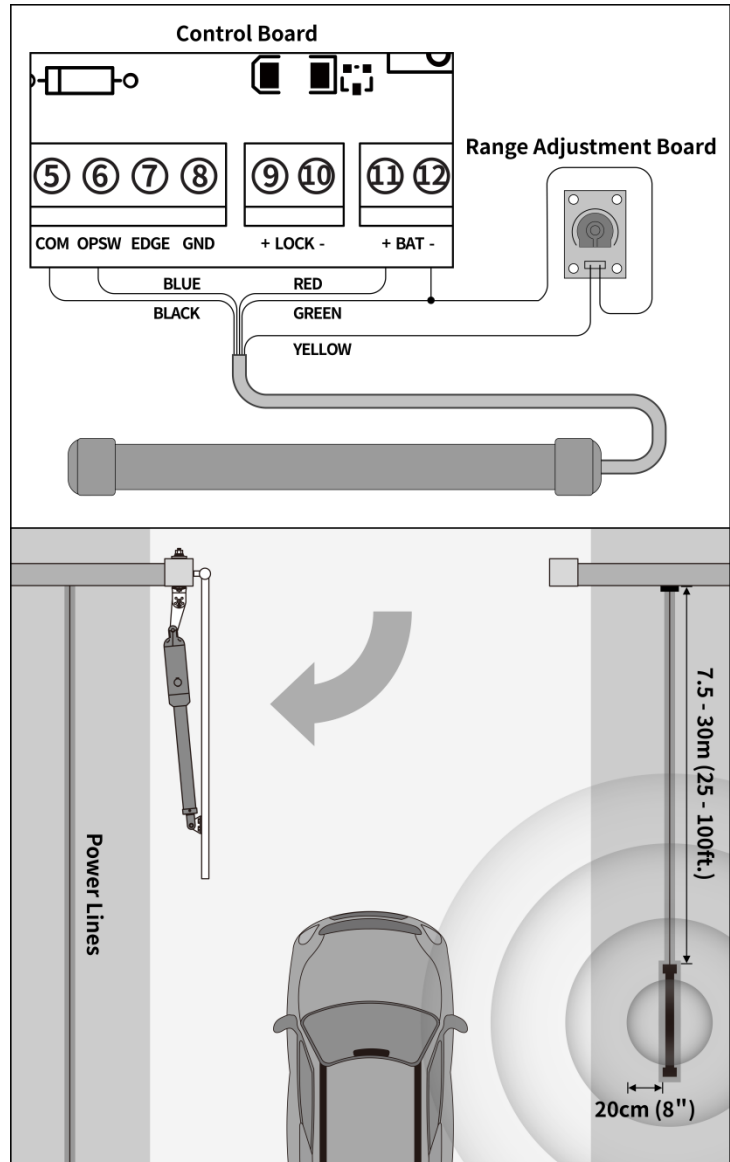

NOTE: If the gate opener is ONLY solar powered, please add more solar panels and upgrade the battery capacity to support the additional power consumption by the exit wand.

Connection of Accessories

TC175P Wired Keypad

Operate the gate with a user defined password / ID card

Wire Connection

- ◆ Connect the wires from the JP2 terminals of the wired keypad to the control board.
- ◆ Connect the BLUE wire to the control board terminal ④ “O/S/C” .
- ◆ Connect the BLACK wire to the control board terminal ⑤ “COM” .
- ◆ Connect the PURPLE wire to the control board terminal ⑤ “COM” .
- ◆ Connect the RED wire to the control board terminal ⑪ “BAT+” .

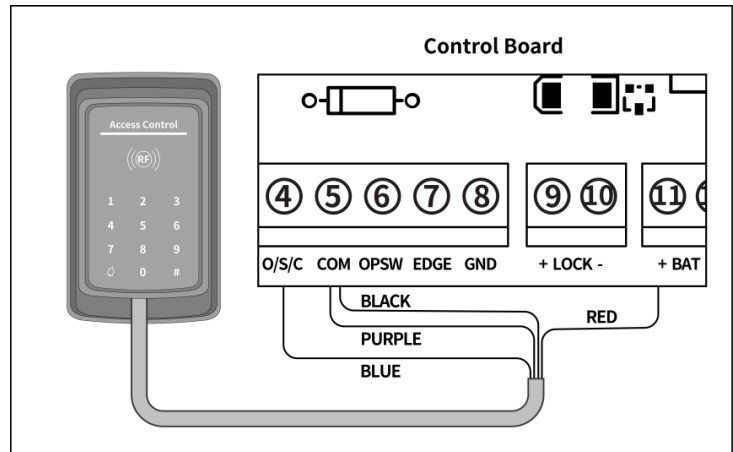

NOTES:

- ◆ A 4C x 0.3 mm² (22AWG) cable is required for the wire connection, but it is NOT included.
- ◆ Please see detailed password setting steps in TC175P user manual.
- ◆ If the gate opener is ONLY solar powered, please add more solar panels and upgrade the battery capacity to support the additional power consumption by the wired keypad.

HLR01 Homelink Remote Control Kit

Links the gate opener with your car's HomeLink system, allows for easy control of the gate opener through the HomeLink system.

Wire Connection

- ◆ Connect terminal ① to the control board terminal ⑤ “COM” .
- ◆ Connect terminal ② to the control board terminal ④ “O/S/C” .
- ◆ Connect terminal ⑦ “+DC” to the control board terminal ⑪ “BAT+” .
- ◆ Connect terminal ⑧ “DC-” to the control board terminal ⑫ “BAT-” .

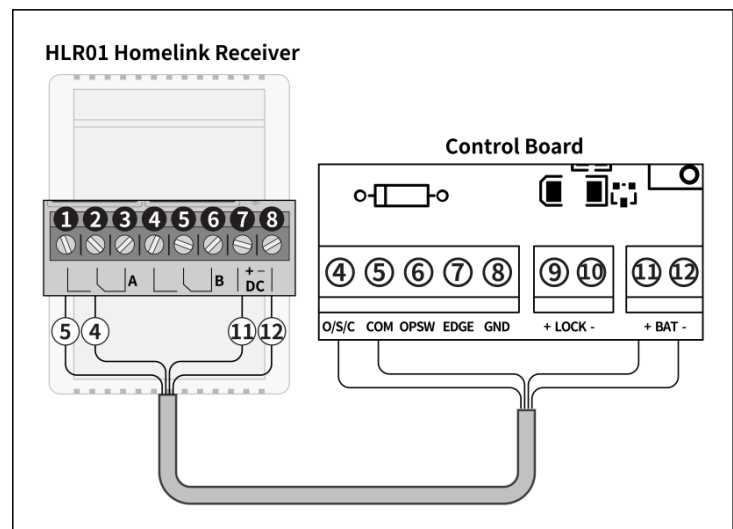

NOTES:

- ◆ A 4C x 0.3 mm² (22AWG) cable is required for the wire connection, but it is NOT included.
- ◆ Please see detailed programming steps with Homelink system in HLR01 user manual.
- ◆ If the gate opener is ONLY solar powered, please add more solar panels and upgrade the battery capacity to support the additional power consumption by the Homelink receiver.

Connection of Accessories

JD24VY Warning Light

Flashing when the gate is moving, improving your gate safety

Wire Connection

- ◆ Connect the RED wire to the control board terminal ⑮ “LAMP+” .
- ◆ Connect the BLACK wire to the control board terminal ⑯ “LAMP-”.

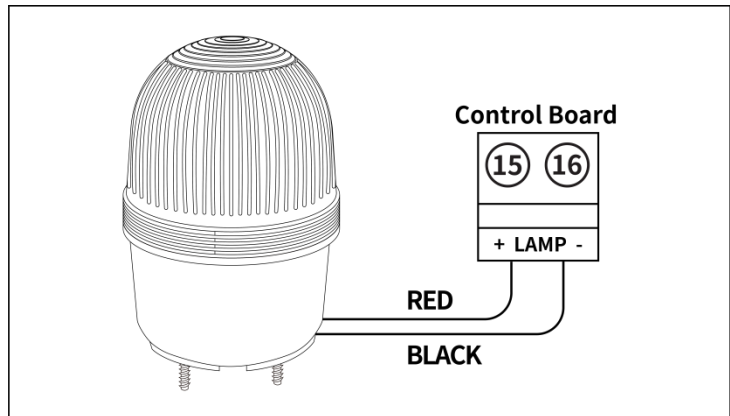

NOTE: A 2C x 0.3 mm² (22AWG) cable is required for the wire connection, but it is NOT included.

TRF3 Reflection Photocell Sensor

Prevents the gate from closing when obstructed, adds security with simple wire connection

Wire Connection

- ◆ Connect “ 10-25VAC/12-30VDC ” terminals to the control board terminal ① “+24” and terminal ③ “GND” , regardless of the polarity of the wires. Connect “NC” terminal to the control board terminal ② “PHOTO” . Connect “COM” terminal to the control board terminal ③ “GND” .
- ◆ Set the DIP switch #3 to **ON** to enable the photocell sensor function.

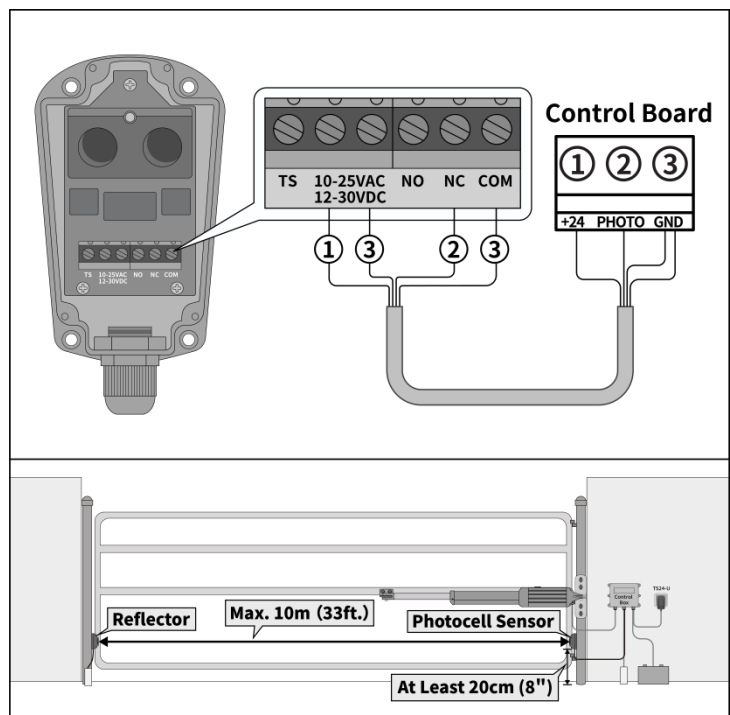

Key Installation Notes

- ◆ Mount the photocell sensor at least 20cm (8") above the ground.
- ◆ Power on the gate opener. Position the reflector directly opposite the mounted photocell sensor. With a press of the remote control, the photocell sensor working light turns to green, confirming that the reflector is in the correct position.
- ◆ The maximum sensing range of the photocell sensor is 10m (33ft.).

NOTE: A 4C x 0.3 mm² (22AWG) cable is required for the wire connection, but it is NOT included.

Connection of Accessories

TC102 Infrared Photocell Sensor

Prevents the gate from closing when obstructed, adds security

Wire Connection

- ◆ For the emitter, connect “~ +” terminal to the control board terminal ① “+24”, connect “~ -” terminal to the control board terminal ③ “GND” .
- ◆ For the receiver, connect “~ +” terminal to the control board terminal ① “+24”, connect “~ -” terminal to the control board terminal ③ “GND” . Connect the “NC” terminal to the control board terminal ② “PHOTO” , connect “COM” terminal to the control board terminal ③ “GND” .
- ◆ Set the DIP switch #3 to **ON** to enable the photocell sensor function.

Key Installation Notes

- ◆ Mount the photocell sensor at least 20cm (8") above the ground.
- ◆ Place the receiver on the control box side of the gate opener, directly facing the emitter.
- ◆ Ensure that both the emitter and receiver are aligned with each other. If manual precise alignment is difficult, use a visible laser beam for assistance.
- ◆ The maximum sensing range is 20m (65ft.), and the recommended distance between the emitter and receiver is 3m to 14m (10ft. to 46ft.).
- ◆ Put the cables into PVC conduit and bury the conduit underground to prevent damage.

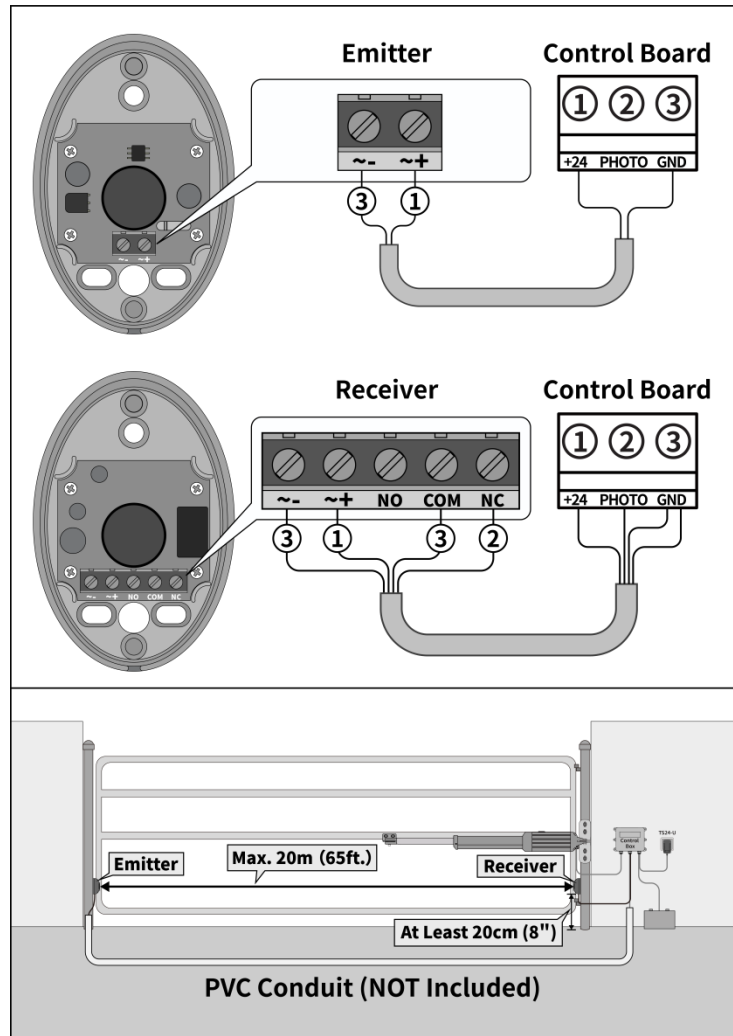

NOTE: Connect the emitter to the gate opener with a 2C x 0.3 mm² (22AWG) cable. Connect the receiver to the gate opener with a 4C x 0.3 mm² (22AWG) cable. Cables are required but NOT included.

Connection of Accessories

ERM12 External Receiver

Allows up to 250 remotes to be programmed with the gate opener

Wire Connection

- ◆ Connect the BROWN wire to the control board terminal ④ "O/S/C".
- ◆ Connect the BLACK wire to the control board terminal ⑤ "COM".
- ◆ Connect the RED wire to the control board terminal ⑪ "BAT+".

Program the Remote Control with the Receiver

- ◆ Before programming, ensure the M12 remote control is removed from the control board to avoid conflicts.
- ◆ Press and release the Learn Button on the receiver, the LED light will turn ON. Press the remote control button you want to program once, then press it again after the LED on the remote turns off.
- ◆ The LED Light on the receiver will flash for 3 seconds and then turn OFF indicating successfully programming.

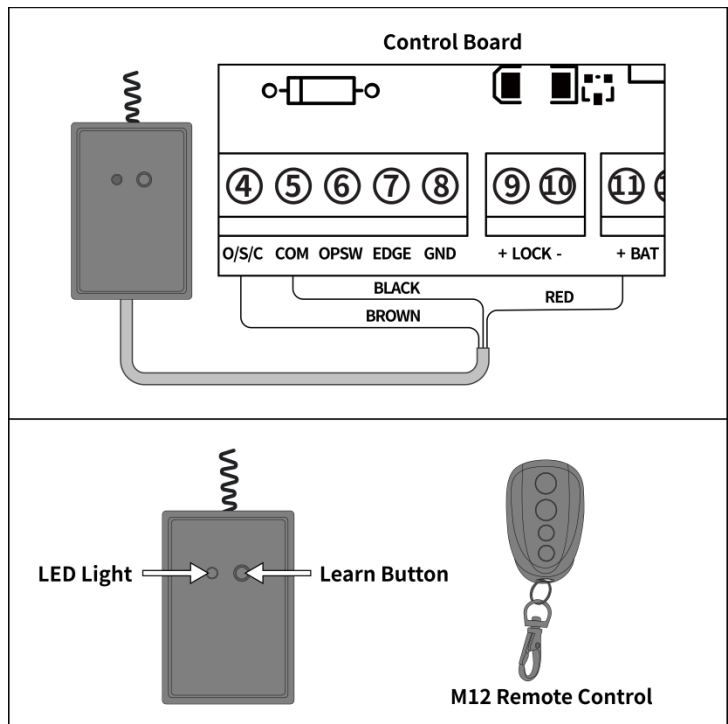

NOTE: If the gate opener is ONLY solar powered, please add more solar panels and upgrade the battery capacity to support the additional power consumption by the receiver.

TC148 Waterproof Wall Push Button & TC147 Wall Push Button

Open/close gate by pressing wired button

Wire Connection

- ◆ Connect the push button to the control board terminal ④ "O/S/C" and terminal ⑤ "COM", regardless of the polarity of the wires.
- ◆ Each press of the button will cycle the gate through open, stop, close, stop, and open.

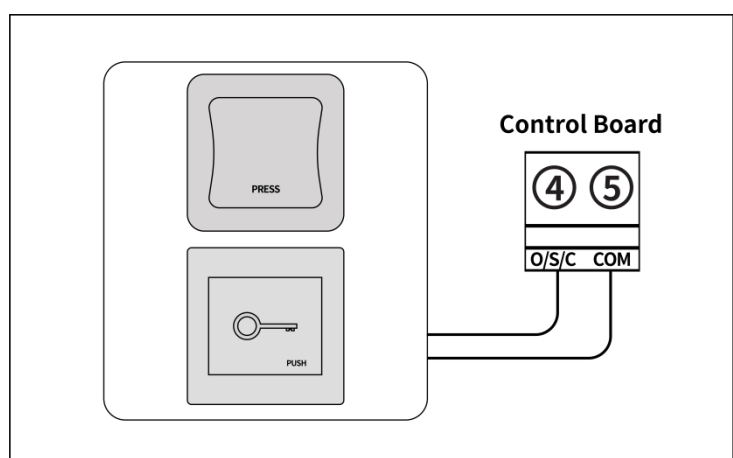

NOTE: A 2C x 0.3 mm² (22AWG) cable is required for the wire connection, but it is NOT included.

Maintenance and Replacement Parts

Maintenance

WARNING

Disconnect all power (AC and battery) to the gate opener before routine inspections and lubrication.

Routine Inspections

- ◆ **Inspect the Gate:** Check for any signs of damage, rust, or wear on the gate and hinges.
- ◆ **Check Gate Opener Arm:** Check that the arm is securely attached to both the gate and post brackets. Tighten any loose bolts and screws.
- ◆ **Examine Cables and Wires:** Ensure that all cables and wires are intact, without any cuts or frays.
- ◆ **Battery Maintenance:** Regularly check for battery leakage and ensure that its casing is intact. Monitor the battery voltage through the control board. Replace the battery every 2-3 years and recycle old batteries properly.

Cleaning and Lubrication

- ◆ Using a clean, dry cloth to wipe the gate opener shaft, and then apply a silicone spray to reduce its friction.
- ◆ In cold climates where temperatures drop to 1° C (30° F) or below, apply silicone spray to the gate opener arm every 4-6 weeks to prevent freezing. Ensure the silicone freezing point is lower than the lowest local temperature.

Monthly Obstruction Test

The gate must reverse when encountering a solid object during closing and stop during opening. If the stall force is adjusted, retest the gate opener by referring to the Stall Force Adjustment & Obstruction Test section in this manual. Failure to properly adjust and retest the gate opener can increase the risk of injury or death.

Replacement Parts

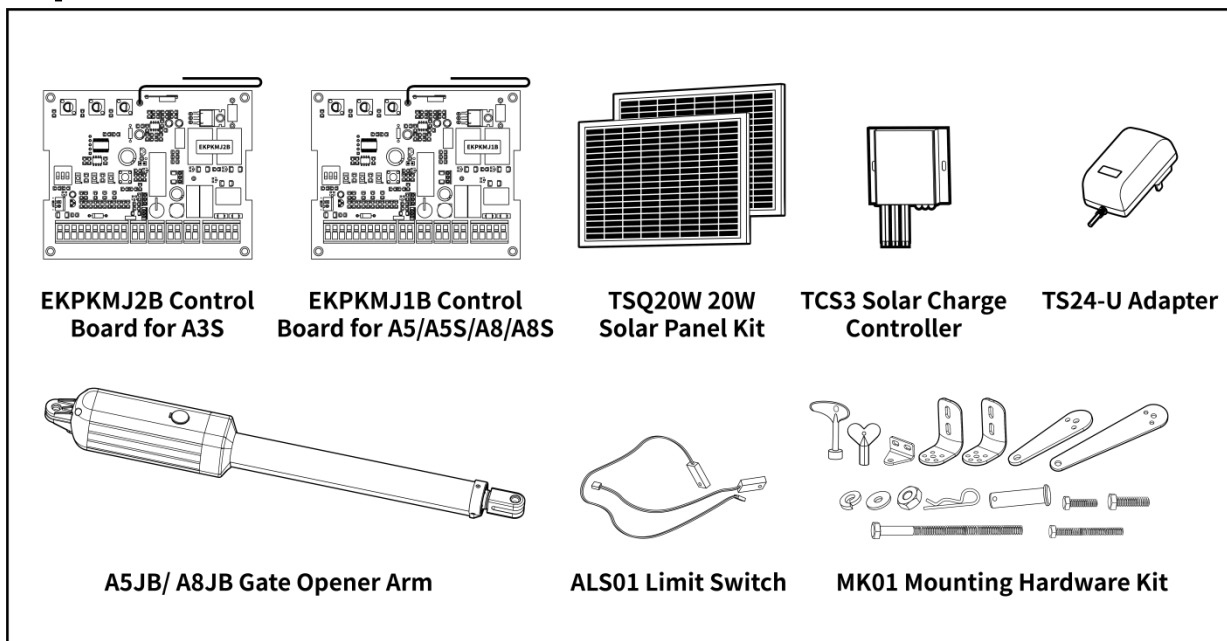

* Available on the TOPENS website (www.topens.com) and Amazon.

Gate Opener Status Trouble Shooting

If your gate opener does not function properly after installation, please follow the steps below before contacting us for assistance. This guide provides common trouble shooting steps to help resolve issues efficiently. For further assistance, please feel free to contact us through our website at www.topens.com.

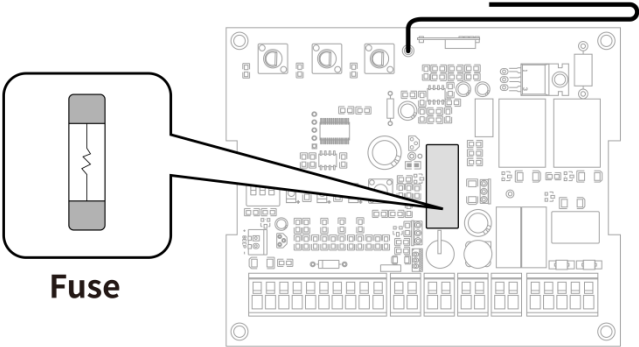
Symptom	Possible Solution(s)
<p>The opener does not run Power LED does not ON</p>	<p>Step 1 Check Connection: Ensure that the connection between the batteries and the control board is correct and secure.</p> <p>Step 2 Verify Power Supply: Confirm that the TS24-U adapter is plugged into an AC main socket or that the batteries (two 12V batteries connected in series) are properly connected to the TCS3 solar charge controller.</p> <p>Step 3 Check Battery Voltage: If only battery is used to power the gate opener, ensure it is not over-discharged. The voltage should be above 22V for normal operation. Allow the battery to charge until it reaches above 22VDC.</p> <p>Step 4 Inspect TCS3 Solar Charge Controller Output: If solar panels and the TCS3 solar charge controller are used to charge batteries, measure the output voltage of the TCS3 solar charge controller. If it is below 21VDC while the battery voltage is above 22VDC, the solar charge controller may be defective.</p> <p>Step 5 Examine Control Board Fuse: Check the fuse in the control board and replace it with the backup fuse that comes with the gate opener if it burns out. The fuse type is $\varnothing 5 \times 20$mm 5A 250VAC fast blow glass fuse.</p> <div data-bbox="451 1227 1425 1601" style="border: 1px dashed gray; padding: 10px; text-align: center;">  <p data-bbox="635 1507 711 1541">Fuse</p> </div> <p>Step 6 Check Control Board: Inspect the control board and replace it if needed.</p>
<p>The opener does not run. Only the CODE LED is ON slightly</p>	<p>Check Wire Connection: Ensure the batteries are properly connected to the control board, and verify that the wire connections are secure. Please note that two 12VDC batteries are required to power the gate opener. The included adapter is only intended for charging the batteries, not for directly powering the gate opener.</p>

Gate Opener Status Trouble Shooting

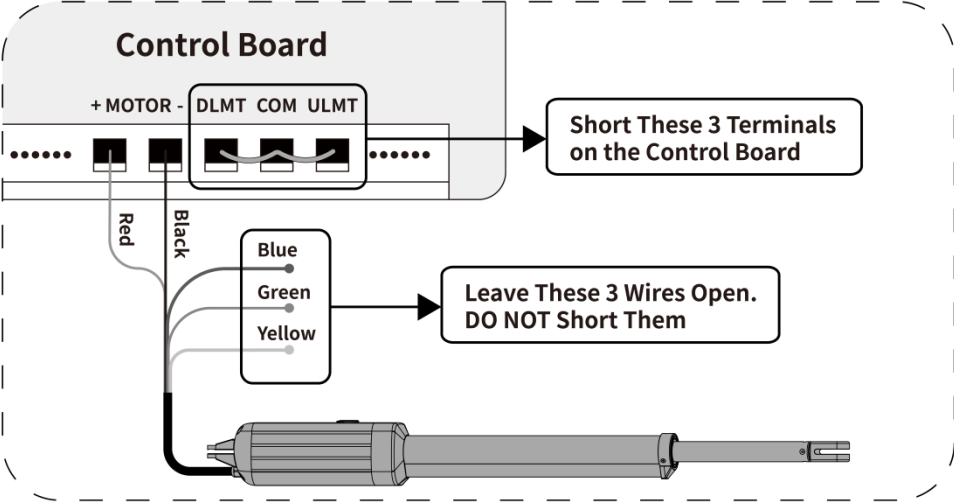
Symptom	Possible Solution(s)
<p>Gate opener does not run when you press the remote control The control board POWER LED: Flash (1 Blink every second)</p>	<p>Step 1 Check Remote Control Programming: Ensure that the remote control is correctly programmed to the control board. If not, refer to the Program the Remote Control section in this manual to reprogram the remote.</p> <p>Step 2 Replace Remote Control Battery: The remote control battery may be exhausted. Replace the battery with a new one and attempt to operate the gate again.</p> <p>Step 3 Check the Limit Switch: Remove the BLUE, GREEN, and YELLOW wires of the arm from the control board and use a jumper wire to short the DLMT, COM, and ULMT terminals on the control board where the three wires were connected. Then, try operating the gate again. If the arm runs normally, the limit switch is faulty.</p>  <p>Step 4 Inspect the Control Board: The control board might be faulty. Inspect the control board for any visible damage or malfunction. If needed, replace the control board with a new one.</p>
<p>Gate can open but does not close</p>	<p>Step 1 Check Photocell Sensor Beam Blockage: Make sure the photocell sensor beam is not blocked if a photocell sensor is used.</p> <p>Step 2 Check the Limit Switch: Remove the BLUE, GREEN, and YELLOW wires of the arm from the control board and use a jumper wire to short the DLMT, COM, and ULMT terminals on the control board where the three wires were connected (refer to the diagram above for guidance). Then, try operating the gate again. If the arm runs normally, the limit switch is faulty.</p> <p>Step 3 Inspect the Control Board: The control board might be faulty. Inspect the control board for any visible damage or malfunction. If needed, replace the control board with a new one.</p>

Gate Opener Status Trouble Shooting

Symptom	Possible Solution(s)
Gate automatically opens, but does not automatically close	<p>Check DIP Switch Setting: The setting of DIP switch #1 may be incorrect. DIP Switch #1 on the control board is used to select the gate's operation mode (push/pull to open). If the gate opens into the property (pull to open), set the DIP Switch to OFF (factory default setting). If the gate opens out from the property (push to open), set the DIP Switch to ON.</p>
Remote control range less than 20m (65ft.)	<p>Step 1 Adjust the Position and Direction of the Antenna: Open the control box and locate the black antenna on the top of the control board. Adjust the position and direction (vertical, horizontal or tilted) of the antenna to optimize signal reception. Test the gate operation with the remote control to check if the control range has improved. If the range remains insufficient, proceed to Step 2.</p> <p>Step 2 Pull the Antenna Out from the Control Box: Pull the antenna through the cable gland at the bottom of the control box and extend it fully straight for optimal signal reception. Test the gate operation with the remote control to check if the control range has increased. If the range is still insufficient, proceed to Step 3.</p> <div data-bbox="454 1039 1423 1406" data-label="Image"> </div> <p>Step 3 Add an ERM12 External Receiver: Connect the ERM12 external receiver to the control board of the gate opener. Program the M12 remote control with the ERM12 external receiver. Before programming, ensure the M12 remote control is removed from the control board to avoid conflicts. After programming, test the remote control to see if the range has improved.</p>
The opener does not run. Power LED flash rapidly (the LED is ON 200ms per second, normally the LED ON 500ms per second).	<p>Check Battery Voltage: The battery may be over-discharged. Check the battery voltage to ensure it is above 22V, as this is necessary for the gate opener to function properly.</p>

Gate Opener Status Trouble Shooting

Symptom	Possible Solution(s)
Gate opens randomly	<p>Step 1 Check DIP Switch Setting: DIP Switch #1 on the control board is used to select the gate's operation mode (push/pull to open). If the gate opens into the property (pull to open), set the DIP Switch to OFF (factory default setting). If the gate opens out from the property (push to open), set the DIP Switch to ON.</p> <p>Step 2 Isolate the Issue with Wired Accessories: Disconnect all wired accessories from the control board. Turn off DIP Switch #3 to disable the photocell sensor function. Try operating the gate again. If the problem disappears, the issue might be with one of the accessories. Connect each accessory one by one to identify which one causes the problem. If the issue is still present after disconnecting all accessories, proceed to Step 3.</p> <p>Step 3 Reprogram Remote Controls: First remove all existing remote codes from the control board and then reprogram the remote controls. Operate the gate to see if the random opening issue has been resolved.</p> <p>Step 4 Replace the Control Board: If none of the above steps resolve the issue, the control board may be faulty. Replace the control board with a new one.</p>
Soft stop function is abnormal	<p>Step 1 Turn Off the Power to the Gate Opener and Restart It: If you have used the release key to manually open the gate or reset the soft stop time, turn off the power to the gate opener and restart it. Then, use the remote control to run a complete open and close cycle to calibrate the full open and close times.</p> <p>Step 2 Check the Limit Switch: Check if the limit switch is functioning and can stop the gate.</p> <p>Step 3 Check If the Soft Stop Functions Correctly: Test the soft stop function when it is not mounted on the gate. If it functions properly, ensure the gate is level, swings freely on its hinges, and that the gate opener is not affected by the inertia of gate opening and closing or by any gate spring force.</p> <p>Step 4 Replace the Control Board: If none of the above steps resolve the issue, the control board may be faulty. Replace the control board with a new one.</p>
Gate moves a little and then reverse or stop	<p>Step 1 Adjust Stall Force: The stall force setting might be too low. Turn off the power to the gate opener, then locate FORCE Potentiometer on the control board and turn it slightly clockwise to increase the stall force. After adjusting, use the remote to open and close the gate to check if the issue is resolved.</p> <p>Step 2 Check for Free Swinging: Disconnect the gate from the gate opener and ensure the gate swings freely without any binding.</p>

DECLARATION OF CONFORMITY



CTS

CTS (NINGBO) TESTING SERVICE TECHNOLOGY
OPERATE ACCORDING TO ISO/IEC 17025

EC DECLARATION OF CONFORMITY

EU - ELECTROMAGNETIC COMPATIBILITY DIRECTIVE -

This declares that the following designated product

swing gate opener

Model No.: EK700M, EK280, EK365,
A3(EK280), A5(EK365), A8(EK700M)

(Product identification)

Complies with the essential protection requirements of the European Parliament and of the Council Directive 2014/30/EU on the approximation of the laws of the Member States relating to electromagnetic compatibility.

This declaration applies to all specimens manufactured in accordance with the attached manufacturing drawings which form part of this declaration.

Assessment of compliance of the product with the requirements relating to electromagnetic compatibility was based on the following standards:

EN 55014-1:2017,
EN 55014-2:2015

(Identification of regulations / standards)

This declaration is the responsibility of the Applicant / importer

HANGZHOU SANFORD TOOLS CO.,LTD.
8 SHENG Di ROAD , YUHANG TOWN, HANGZHOU 311121 ,CHINA

(Name / Address)



THIS DOC IS ONLY VALID IN CONNECTION WITH TEST REPORT NUMBER: CNB3180705-00517-E

MANUFACTURER / IMPORTER

TEST LABORATORY

This is the result of test, that was carried out from the submitted type-samples of a product in conformity with the specification of the respective standards.
The declaration holder has the right to fix the CE-mark for EMC on the product complying with the inspection sample

(Date)

17 July 2018

(Date)

(Surname, forename)

(Company stamp)

(Company stamp)



CTS (Ningbo) Testing Service Technology Co., Ltd.
NB test site: Fl.1 & 8 West, Bldg. B, No. 66, Qingyi Rd., Hi-Tech Zone, Ningbo, Zhejiang, China
GZ test site: A101, No.65, Zhuji Road, Tianhe District, Guangzhou, Guangdong, China

DECLARATION OF CONFORMITY



CTS

CENTRE OF TESTING SERVICE
OPERATE ACCORDING TO ISO/IEC 17025

EC DECLARATION OF CONFORMITY EU - LOW VOLTAGE DIRECTIVE -

This declares that the following designated product:

Swing gate opener
Model No.: EK700M, EK280, EK365, A3(EK280)
A5(EK365), A8(EK700M)
.....
(Product identification)

Complies with the requirements of the European Community Directive 2014/35/EU.
This declaration is awarded following tests carried out on samples of the product referred to above.
Assumption of compliance of the product with the requirements relating to the
Low Voltage Directive (LVD) was based on the following standards:

EN 60335-1: 2012+A11:2014
EN 60335-2-103:2015
.....

(Identification of regulations / standards)

This declaration is the responsibility of the manufacturer / importer

HANGZHOU SANFORD TOOLS CO., LTD.
8 SHENG DI ROAD, YUHANG TOWN, HANGZHOU 311121, CHINA
.....

(Name / Address)



THIS DOC IS ONLY VALID IN CONNECTION WITH TEST REPORT NUMBER: CNB3180705-00519-1.

MANUFACTURER / IMPORTER

.....
(Date)

.....
(Surname, forename)
.....
(Company stamp)

TEST LABORATORY

This is the result of test that was carried out from the submitted type-samples of a product in conformity with the specification of the respective standards.
The declaration holder has the right to fix the CE-mark for LVD on the product complying with the inspection sample.

31 July 2018

.....
(Date)

Lei Zhang
.....
(Company stamp)



CTS (Ningbo) Testing Service Technology Co., Ltd.

Fl.1 & 8 West, Bldg. B, No. 66, Qingyi Rd., Hi-Tech Zone, Ningbo, Zhejiang, China

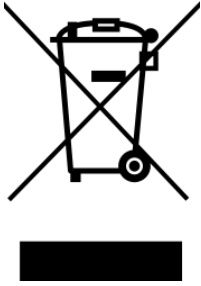

According to Waste of Electrical and Electronic Equipment (WEEE) directive, WEEE should be separately collected and treated. If at any time in future you need to dispose of this product, please do NOT dispose of this product with household waste. Please send this product to WEEE collecting points where available.

Feedback & Review

Your comments and suggestions are important to us
as they help us provide the best possible service.

Should you have any need to contact us, the info below will help you get in touch:



TOPENS Website

www.topens.com

Contact Us:

E-mail: support@topens.com

Kindly include your purchase channel, order #, gate information, issue description and your contact information. All your concerns will be replied within 24 hours.

Tel: +1 (888) 750 9899 (Toll Free USA & Canada)