

GENERAL INFORMATION:

Most underbar units ship with items that are to be installed at the job site. Below is a check list of items that should be included in the carton with the unit:

Unit	Leg(s)(1)	Faucet(s)	Drain(s)	Overflow(s)	Bottle Wells	Cover
Underbar Sinks	✓	✓	✓	✓	--	--
Deli Units	✓	✓	✓	--	--	--
Drop-In Sinks	--	✓	✓	--	--	--
Combination Units	✓	✓	✓	✓	--	✓
Ice Chests	✓	--	✓	--	--	✓
Ice Chest Stations	✓	✓(2)	✓	--	--	✓
Glass Rack	✓	--	✓(4)	--	--	--
Bottle Storage Display	✓	--	--	--	--	--
Slanted Liquor Display	✓	--	--	--	--	--
Open Storage Rack	✓	--	--	--	--	--
Underbar Storage Units	✓	✓(2)	✓	--	--	--
Pass Thrus	✓	--	✓	--	--	✓
Drainboards	✓	--	✓	--	--	--
Filler Sections	(3)	--	--	--	--	--
Add-On Units	✓	✓(2)	✓(4)	--	✓	--
Wall-Mount Hand Sink	--	✓	✓	--	--	--
Drop-In Concession Sinks	--	✓(2)	✓	--	--	--

NOTES:

- (1) Legs include mounting hardware
- (2) Some models have a faucet
- (3) Model DC90FS ships with one leg assembly
- (4) Some models have a drain

INSTALLATION INSTRUCTIONS

1. Carefully remove unit from carton. Leg assemblies, mounting hardware and other "standard" items, are packaged separately, but ship in the unit carton.
2. To prevent any scratching, flatten out carton and place unit upside down on it.
3. Using enclosed sheet metal screws, attach leg assemblies (see drawing at right).
4. Place unit upright at installation location.
5. Level the unit by turning adjustable feet.
6. Attach all other necessary hardware and plumbing, making sure local codes are followed.

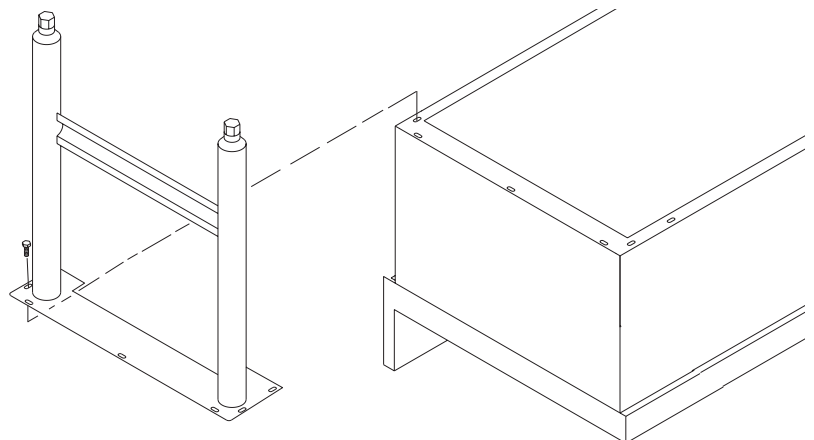

PROPER CARE AND CLEANING

HOW TO CLEAN STAINLESS STEEL:

Under ordinary conditions, the secret of keeping your stainless surfaces bright as new is simple: light but frequent cleaning, usually with no more than a damp cloth. Then dry with a soft cloth.

For slightly more difficult applications, you may use any of the following (1) ammonia in water, (2) detergent in water, or (3) special solvents, such as alcohol, baking soda, vinegar or turpentine. Follow these with a thorough washing with detergent and hot water, then rinse and dry with a soft, clean cloth. For a high polish, apply a mild abrasive cleanser and rub in the direction of the polish lines to preserve the original finish. You must always be careful not to rub in dirt that is on the metal surface when you clean.

PRECAUTIONS:

1. Strong bleaches tend to corrode many materials and should not come in contact with stainless steel sinks or utensils longer than 30 minutes. When these chemicals are used, the stainless should be rinsed thoroughly. (Warranty does not cover pitting from bleach misuse.)
2. Some foods, such as mustard, mayonnaise, lemon juice, vinegar, salt, or dressings containing these, will attack and corrode stainless.
3. Ordinary steel wool should not be used to clean stainless; particles may lodge in the surface and rust. Allowing the wool to rest on a stainless surface may cause a rusty appearance. For difficult cleaning jobs, stainless steel "sponges" or pads are recommended.
4. Gritty, hard abrasives will mar a stainless finish and are not recommended.
5. Sharp knives or choppers usually have hard carbon steel edges and will leave their mark on stainless surfaces.

IMPORTANT TOP (FOR YOUR UNDERBAR SINK):

When you close for the day, don't just pull the overflow pipes and leave. Take time to thoroughly rinse solutions from each tank. It will keep your unit looking new and add years to its functional life.

LIMITED WARRANTY

LaCrosse extends a limited warranty to the original user on the products it manufactures. All products are under warranty to be free of original defects, material or workmanship, under normal use and service for a period of one (1) year from date of shipment. Proof of purchase must accompany all warranty claims. Parts will be replaced or repaired at the company's option on a no-charge basis (except for labor). Inspection by and at the LaCrosse factory, of parts claimed defective, shall be final in determining warranty status. The manufacturer is not responsible for any damage or business loss of any kind resulting from a defect in the unit, or for any charges related to the removal of a defective unit or installation of a replacement unit.

This warranty shall be considered VOID if: the unit is installed by someone other than a licensed plumber or not in accordance with local code; the unit is altered or modified; the unit has any accessory parts attached which are not recommended or installed by the manufacturer; THE UNIT IS CLEANED With CHEMICALS OR DETERGENTS NOT IN ACCORDANCE With THE MANUFACTURER'S DIRECTIONS OR NOT RECOMMENDED FOR USE ON STAINLESS STEEL.

EXCLUSIVE REMEDY. If the goods purchased in connection with this document are returned by Purchaser FOB, LaCrosse's Onalaska plant pursuant to written authorization and instructions from LaCrosse within the applicable warranty period set forth above and such goods are found to be defective by LaCrosse under one of the applicable foregoing Limited Warranties, LaCrosse will at its sole election either (a) repair or replace such defective goods at LaCrosse's cost or or (b) accept the return of such defective goods at the invoice price of such goods for a credit.

THE WARRANTY SET FORTH ABOVE IS THE EXCLUSIVE WARRANTY PROVIDED BY LACROSSE, AND ALL OTHER WARRANTIES, INCLUDING ANY IMPLIED WARRANTIES OR MERCHANTABILITY OR FITNESS FOR A PARTICULAR PURPOSE, ARE EXPRESSLY DISCLAIMED. IN THE EVENT ANY IMPLIED WARRANTY IS NOT HEREBY EFFECTIVELY DISCLAIMED DUE TO OPERATION OF LAW, SUCH IMPLIED WARRANTY IS LIMITED IN DURATION TO THE DURATION OF THE APPLICABLE WARRANTY STATED ABOVE. THE REMEDIES SET FORTH ABOVE ARE THE SOLE AND EXCLUSIVE REMEDIES AVAILABLE HEREUNDER. LACROSSE WILL NOT BE LIABLE FOR ANY INCIDENTAL OR CONSEQUENTIAL DAMAGES DIRECTLY OR INDIRECTLY RELATED TO THE SALE, HANDLING OR USE OF THE EQUIPMENT, AND IN ANY EVENT LACROSSE'S LIABILITY IN CONNECTION With THE EQUIPMENT, INCLUDING FOR CLAIMS BASED ON NEGLIGENCE OR STRICT LIABILITY, IS LIMITED TO THE PURCHASE PRICE THEREFORE.

L#1038.1016

