

COMPACTOR

Use & Care Guide

For questions about features, operation/performance parts, accessories or service, call: **1-800-253-1301**.

In Canada, call for assistance **1-800-461-5681**, for installation and service, call: **1-800-807-6777**

or visit our website at...

www.whirlpool.com or www.whirlpool.com/canada

Table of Contents	2
-------------------------	---

TABLE OF CONTENTS

COMPACTOR SAFETY	3
INSTALLATION INSTRUCTIONS	4
Unpacking	4
Location Requirements	4
Electrical Requirements	5
Freestanding and Undercounter Installation	6
Changing the Decorative Panel	7
COMPACTOR USE	9
How Your Compactor Works.....	9
Loading.....	9
Starting the Compactor	10
Removing a Filled Bag	10
Installing a New Bag	11
COMPACTOR CARE	11
Cleaning.....	11
TROUBLESHOOTING	12
ASSISTANCE OR SERVICE	13
In the U.S.A.	13
In Canada	13
Accessories	13
WARRANTY	16



COMPACTOR SAFETY

Your safety and the safety of others are very important.

We have provided many important safety messages in this manual and on your appliance. Always read and obey all safety messages.



This is the safety alert symbol.

This symbol alerts you to potential hazards that can kill or hurt you and others.

All safety messages will follow the safety alert symbol and either the word "DANGER" or "WARNING." These words mean:

⚠ DANGER

You can be killed or seriously injured if you don't immediately follow instructions.

⚠ WARNING

You can be killed or seriously injured if you don't follow instructions.

All safety messages will tell you what the potential hazard is, tell you how to reduce the chance of injury, and tell you what can happen if the instructions are not followed.

IMPORTANT SAFETY INSTRUCTIONS

WARNING: When using an electrical appliance, basic precautions should always be followed, including the following:

- Read all instructions before using the compactor.
- Close supervision is necessary when used by or near children. Do not allow to be used as a toy, or to run unattended at any time. Lock Key Switch when not in use and store key out of reach of children.
- Do not touch moving parts.
- Do not operate with a damaged cord set, plug, motor, or after damage in any manner. Have the compactor examined, repaired or adjusted by an authorized serviceperson.
- Use only for intended use as described in this manual. Do not use other than manufacturer's recommended attachments.
- Do not compact toxic or volatile flammable material such as oily rags and insect sprays. Do not compact lighted cigarettes, cigars, or other hot or burning items. Do not overload the compactor.
- Do not take apart the compactor. Incorrect reassembly can cause electric shock when subsequently used.
- Handle a loaded trash bag with care. Sharp objects can pierce the bag and cause injury. Do not overload trash bag with heavy material such as glass.
- This compactor is intended for household use only.

SAVE THESE INSTRUCTIONS

INSTALLATION INSTRUCTIONS

Installer: Leave Use and Care Guide with the homeowner.

Homeowner: Keep Use & Care Guide for future reference and for local electrical inspector's use, if required.

Unpacking

IMPORTANT:

- Do not grasp console to move compactor.
 - Begin in the room where the compactor will be located.
1. Remove compactor from shipping carton. Remove all protective packaging materials such as tape and shipping pads. Use a mild solution of liquid household cleaner and warm water to remove waxy residue caused by protective shipping material. Dry thoroughly with a soft cloth. For more information, see the "Cleaning" section.
 2. Check to be sure the power cord is attached to the cord clip on the rear of the compactor.

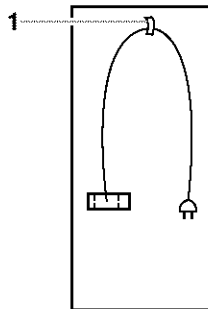

1. Cord clip

3. Place the two corner posts from the carton on the floor near the compactor. Open the compactor drawer and remove any shipping materials or other items from the drawer. Do not remove the compactor bag. Grasp the handle and raise the front of drawer until it clears the drawer stops. Grasp sides of drawer and lift drawer out of compactor. Place the drawer on the two corner posts.

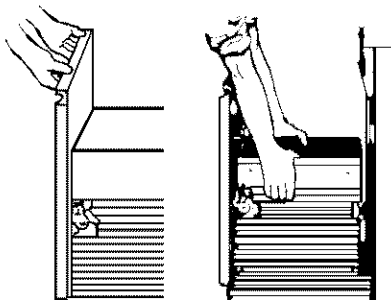

⚠ WARNING

Excessive Weight Hazard

Use two or more people to move and install compactor.

Failure to do so can result in back or other injury.

4. Place the other two corner posts on the floor to the side of the compactor. Grasp the sides of the compactor cabinet and put compactor on its side on top of the corner posts. Remove the shipping base from the bottom of the compactor.

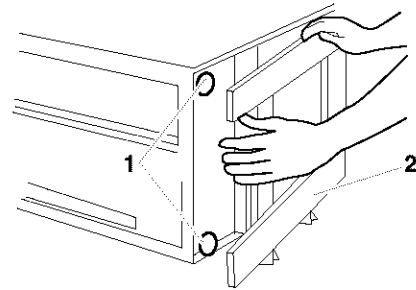

1. Leveling legs
2. Shipping base

Location Requirements

Product dimensions

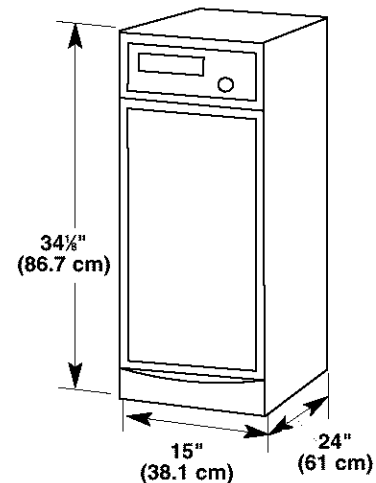

Cutout dimensions

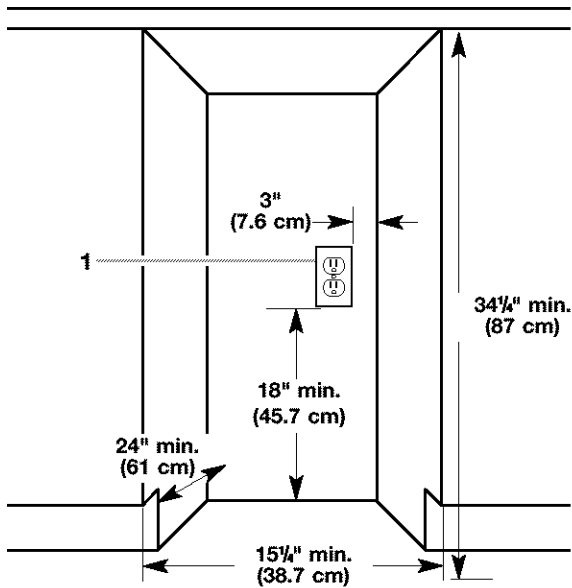

1. Grounded electrical outlet must be a minimum of 3 in. (7.6 cm) away from surrounding cabinets or nearby walls as shown. It can be placed either to the left or the right side of the product.

Clearance dimensions

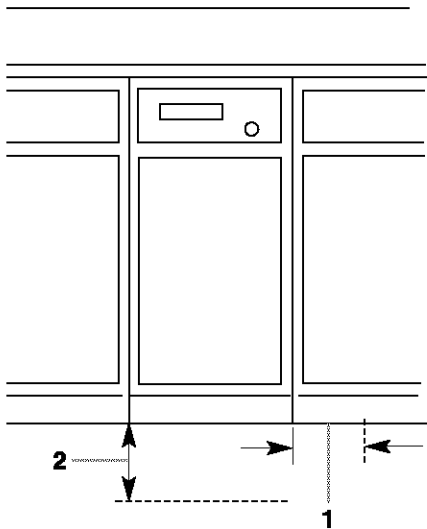

1. Leave 6 in. (15.2 cm) of clearance space to the right side of the compactor in order to remove the compactor bags.
2. Leave 23 in. (58.4 cm) of clearance in front of the compactor in order to fully open or remove the compactor drawer.

Electrical Requirements

⚠ WARNING



Electrical Shock Hazard

Plug into a grounded 3 prong outlet.

Do not remove ground prong.

Do not use an adapter.

Failure to follow these instructions can result in death, fire, or electrical shock.

Recommended Grounding Method

This compactor is for use on a single phase, 115-volt, 60 Hz, AC only 15 or 20 ampere fused and properly grounded circuit and is equipped with a grounding plug as shown below. Time delay fuse or circuit breaker is recommended. It is recommended that a separate circuit serving only this appliance be provided. In the event of an electrical short circuit, grounding reduces the risk of electric shock by providing an escape wire for the electric current. Do not modify the plug attached to the compactor; use only with a grounded receptacle.

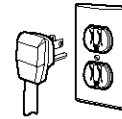

This compactor must be grounded while in use to reduce the risk of electric shock. The compactor is equipped with a three-conductor cord and three-prong grounding-type plug to fit the proper grounding-type receptacle. The green (or green and yellow) conductor in the cord is the grounding wire. Never connect the green (or green and yellow) wire to a live terminal. The outlet should be properly installed and grounded in accordance with the National Electrical Code and Local codes and ordinances. No adapter should be used with this appliance.

Freestanding and Undercounter Installation

NOTE: Proper installation is your responsibility. Make sure you have everything necessary for correct installation. It is the personal responsibility and obligation of the customer to contact a qualified installer to assure that electrical installation meets all National and Local codes and ordinances.

Tools and materials needed for installation:

Level	Phillips No. 2 Screwdriver
Tape Measure	Flat-Head Screwdriver
Pliers	5/16 in. Hex-Head Socket Wrench
Scissors	Utility Knife

IMPORTANT:

- Do not grasp control panel to move compactor.
- Slide compactor onto cardboard or hardboard before moving compactor across floor to prevent damaging floor covering.
- Do not allow the rear frame of the compactor to touch the floor covering when lifting or moving compactor.

Freestanding installation

1. Use pliers to lower leveling legs away from cabinet. Place level inside on the floor of the cabinet. Check that the compactor is level from front to back and side to side. Adjust the leveling legs until the compactor is level.

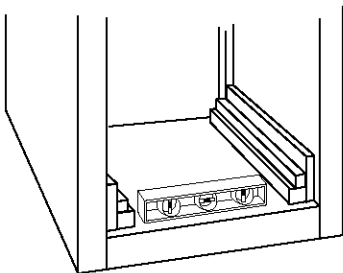

2. Move the compactor close to its final position.
3. Plug into a grounded 3 prong outlet.
4. Carefully move compactor into its final position. Check that compactor is still level. Repeat step 1 if necessary.
5. Grasp sides of compactor drawer and place bottom of drawer into tracks. Lift at the handle so drawer will go over drawer stops. Close drawer. Check to see if drawer opens freely. If the toe plate rubs against floor, see "Adjusting the Toe Plate" for further instructions.

Undercounter installation

NOTE: Installation hardware is not provided with full cabinet models.

1. Measure the height of your cabinet opening. The top of the compactor should be at least 1/8 in. (3 mm) from the top of the cabinet opening.
The rear wheels are preset for a cabinet opening height of 34 1/4 in. (87 cm) (Position A).

To adjust for other cabinet opening heights:

- Loosen self-tapping screw just enough to clear stud from hole in position "A."
- Move the rear wheel and stud to position "B" or "C" as needed for your cabinet opening measurement:
Position B: 34 1/4 in. to 34 7/16 in. (87 to 87.5 cm)
Position C: 34 7/16 in. to 34 5/8 in. (87.5 to 88 cm)
NOTE: To level the unit in position C, you may need to add shims under the leveling legs.
- Tighten screw. Repeat for other rear wheel.

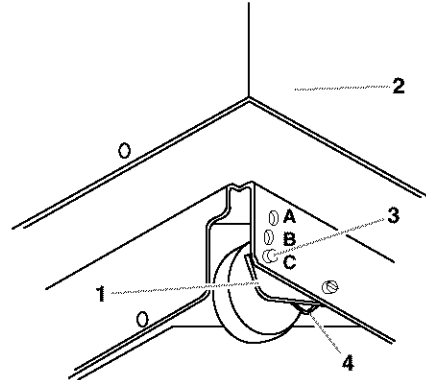

1. Wheel bracket assembly
2. Cabinet
3. Locating stud
4. Self-tapping screw (pivot)

2. Use pliers to lower leveling legs away from cabinet. Adjust legs so there will be a 1/8 in. (3 mm) to 1/4 in. (6.4 mm) space between the top of the compactor and the top of the cabinet opening. Stand the compactor upright.
3. For model with cabinet, remove the plastic plugs from the compactor cabinet top.
4. Move the compactor close to its final position.
5. Plug into a grounded 3 prong outlet.
6. Determine if you want the compactor frame or drawer front flush with the cabinet front.

Using the two #8-18 x 5/16 in. screws, install the retaining brackets to cabinet top as needed:

- If the compactor frame is to be flush with the cabinet front, place retaining bracket screws through "A."
- If the compactor drawer front is to be flush with the cabinet front, place retaining bracket screws through "C."
- If the compactor is to be midway between "A" and "C," place the retaining bracket screws through "B."

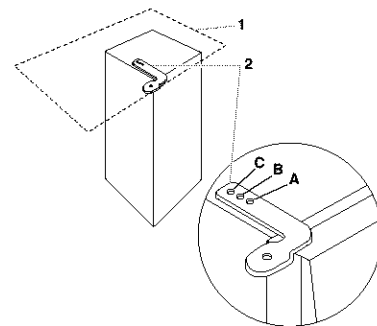

1. Countertop
2. Retaining bracket

- Carefully lift the front slightly and roll compactor into the cabinet opening.

Using the two #8-18 x ½ in. screws, fasten the retaining brackets to the countertop with the mounting screws.

If brackets cannot be attached to the underside of countertop, attach mounting clips to brackets. Fasten compactor to cabinet front with mounting screws through mounting clips.

Countertop mounting

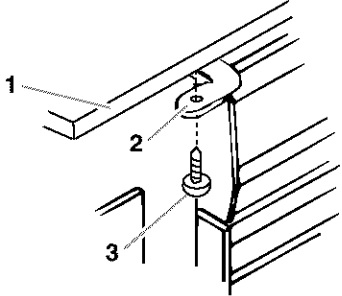

- Countertop
- Retaining bracket
- Mounting screw

Cabinet-front mounting

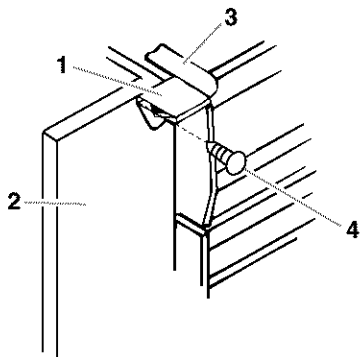

- Mounting clip
- Cabinet
- Retaining bracket
- Mounting screw

- Grasp sides of compactor drawer and place bottom of drawer into tracks. Lift at the handle so drawer will go over drawer stops. Close drawer. Check to see if drawer opens freely. If the toe plate rubs against floor see "Adjusting the Toe Plate" for further instructions.

Adjusting the Toe Plate

If the toe plate rubs the floor covering, the toe plate clearance may be changed as follows:

- Mark on each side of the toe plate the amount of toe plate that rubs the floor covering.
- Remove the drawer from the unit. (See Step 3 in the "Unpacking" section.)
- Use a ruler and a pencil or chalk to draw a line between the marks on each side of toe plate.
- Use scissors or utility knife to cut toe plate along line.
- Replace drawer. If toe plate still rubs floor covering, repeat steps 1-4.

Changing the Decorative Panel

There are three options for changing the decorative panel:

- Order an acrylic panel
- Create a custom panel for use with a trim kit
- Create a custom panel for installation without trim

To order an acrylic panel or a trim kit, see the "Assistance or Service" section for information or call the toll-free number on the cover.

Trim kit panel dimensions

Use these dimension drawings to create a custom panel for use with a trim kit. Then, follow the installation instructions provided with the kit.

Flat panel: A 7/32 in. (5.6 mm) thick panel is required. This is the same thickness as a standard ¼ in. plywood or paneling.

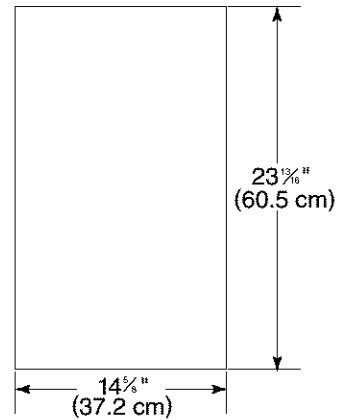

Raised panel: The outer section of panel must be 7/32 in. (5.6 mm) thick to fit into trim. Design raised panel sections using dimensions shown above.

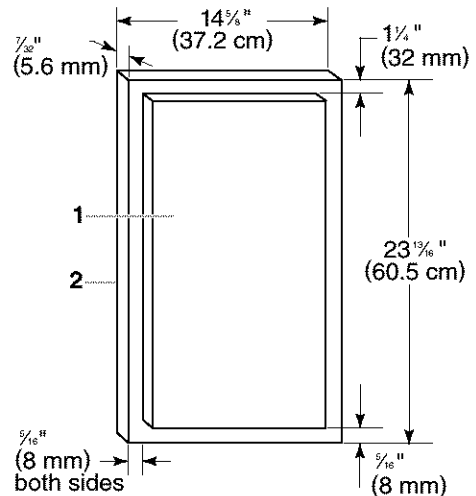

- Raised panel or decorative trim
- Outer section of panel

Trimless panel with handle

Dimensions

Use these dimension drawings to create a custom panel for use without a trim kit. The panel should be $\frac{1}{2}$ in. to $\frac{5}{8}$ in. (13 mm to 16 mm) thick.

NOTE: A thicker panel may need rounded front corners and a cut-out for access to the handle.

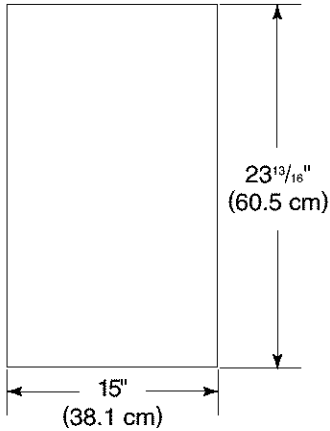

Installation

1. Remove foot pedal, toe guard, and decorative panel.
2. Align the top of the custom panel with the bottom of the handle.
3. Secure the panel from the back using 4 – #8 x 1 in. wood screws as shown.
4. Reinstall the toe guard using the existing screws and $\frac{1}{2}$ in. washer. Then, reinstall the foot pedal.

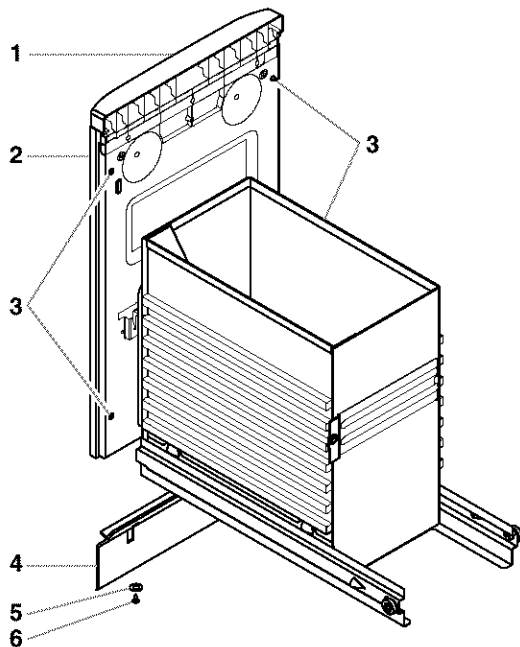

1. Handle
2. Custom Panel
3. #8 x 1" Wood Screws
4. Toe Guard
5. Washer
6. Toe Guard Screw

Trimless panel without handle

Dimensions

Use these dimension drawings to create a custom panel for use without a trim kit. The panel should be $\frac{1}{2}$ in. (13 mm) min. thick.

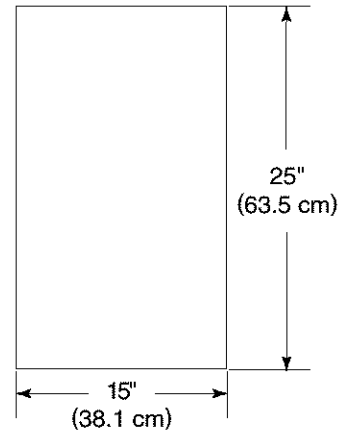

Installation

1. Remove foot pedal, toe guard, decorative panel, and handle.
2. Align the bottom of the custom panel with the bottom of the drawer front.
3. Secure the panel from the back using 4 – #8 x 1 in. wood screws as shown.
4. Attach a 15 in. x $\frac{1}{2}$ in. quarter-round filler along the top of the drawer front using glue or screws.
5. Reinstall the toe guard using the existing screws and $\frac{1}{2}$ in. washer. Then, reinstall the foot pedal.

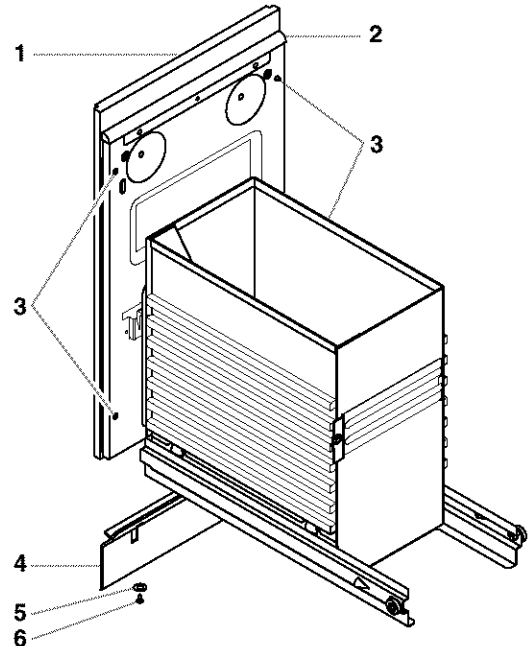

1. Custom Panel
2. 15" x $\frac{1}{2}$ " Quarter-round
3. #8 x 1" Wood Screws
4. Toe Guard
5. Washer
6. Toe Guard Screw

COMPACTOR USE

How Your Compactor Works

The compacting ram is the part of the compactor which compresses the trash. The compacting ram does not go to the bottom of the drawer. You will not see compacting of trash the first few times you load the compactor.

NOTE: The compactor drawer should be more than ½ full before the compactor can begin to compress the load.

You may hear a noise when glass breaks. Strong glass bottles may not break at all. The trash in a full compactor bag will be about ¼ the size of its original bulk.

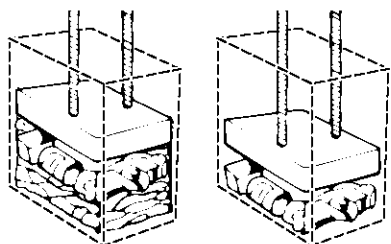

Load bulky trash, bottles, and cans in the center of the drawer. Bottles or cans not placed in the center may become caught between the ram and the drawer. The Drawer Monitor Switch then senses a “misload” and causes the ram to return to the “up” position without compacting.

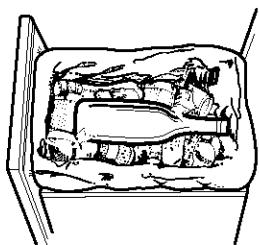

Loading

⚠ WARNING



Explosion Hazard

Do not compact any container, aerosol cans, or cloths which might contain insecticide, hair spray, engine starting fluid, paints, liquids, thinners, or any other poisonous or explosive products.

Doing so can result in death, explosion, or fire.

⚠ WARNING



Cut Hazard

Do not push items down into compactor with hands or feet.

Doing so can result in cuts.

NOTE: You will not see compacting of trash the first few times you load the compactor. The compactor drawer should be about ½ full before the compactor can begin to compress the load.

1. Open the drawer. Lift and pull the handle or press the toe bar to open the drawer.

NOTE: Pressing the toe bar opens the container only 3 in. to 6 in. (7.6 cm to 15.2 cm), depending on the load.

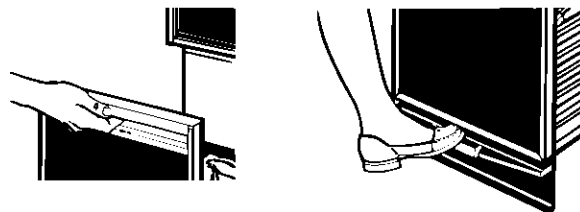

2. Place trash in compactor.
 - Wrap or cover wet or messy trash.
 - Do not compact items that may develop offensive odors such as raw meat, fish, grapefruit rinds, disposable diapers, or personal hygiene items.

- Load bottles or cans on their sides in the center of the drawer. Do not load bottles in an upright position.

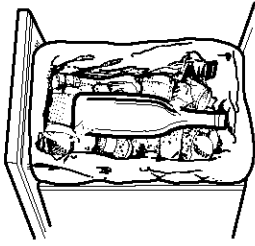

3. Close the drawer.

Starting the Compactor

Depending on your model, you may have a single control (Style 1) or a dual control (Style 2) compactor.

Style 1:

To start and stop the compactor:

1. To start the compactor, turn the Key-Knob to START and then let go. The compactor will automatically stop at the end of the cycle.



2. To stop the compactor during a cycle:
 - Turn the Key-Knob to LOCK/OFF.
 - Then turn the Key-Knob to ON so the compacting ram will rise.
 - When the ram stops rising, you can open the drawer.

To remove the Key-Knob:

1. Turn the Key-Knob to the LOCK/OFF position.
2. Remove the Key-Knob and store it out of children's reach.



Style 2:

To start and stop the compactor:

1. To start the compactor:
 - Turn the Key-Switch to ON.
 - Press ON.
 - Press START. The compactor will automatically stop at the end of the cycle.

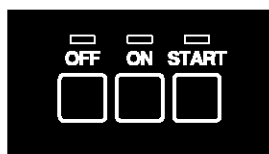
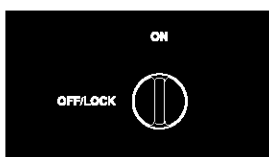

2. To stop the compactor during a cycle:
 - Press OFF.
 - Press ON. The compacting ram will rise. When the ram stops rising, you can open the drawer.

To remove the Key-Switch:

1. Turn the Key-Switch to the OFF/LOCK position.
2. Remove and store key out of children's reach.

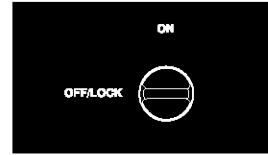

Removing a Filled Bag

When the trash is compacted to the top of the drawer, remove the bag. If the bag is too heavy, compact less trash before emptying it in the future.

⚠ WARNING

Cut Hazard

Do not push items down into compactor with hands or feet.
Doing so can result in cuts.

1. Pull the drawer completely open.
2. Remove top of bag from bag retainer buttons. Pull up all four bag cuffs. Close bag with twist tie provided.

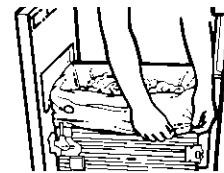

3. Push Side-Lock Latch down and tilt drawer side open.

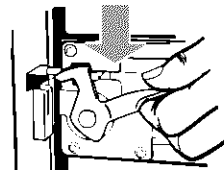

4. Lift out bag.

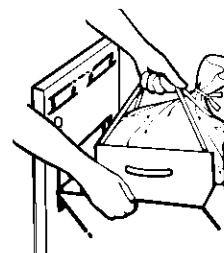

Installing a New Bag

IMPORTANT:

Before installing a new bag, be sure:

- The drawer side is securely locked.
- The container is clean and free of debris.

Do not use any kind of bag other than those designed especially for use in your compactor. Order replacement compactor bags through your local dealer or by calling the toll-free number on the cover or in the "Assistance or Service" section.

1. Place folded bag into the drawer. Open bag and pull top edges over the drawer top.

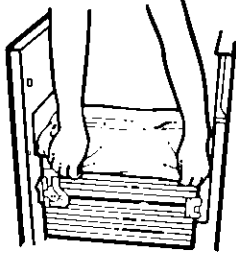

2. Lock bag in place by pulling the four prepunched holes over the bag retainer buttons. Holes will expand over the buttons without damaging the bag.
3. Press inside of bag against the drawer bottom, sides and corners for a smooth fit.

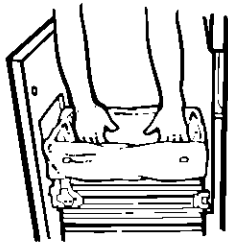

COMPACTOR CARE

Your new compactor is designed to give you many years of dependable service. However, there are a few things you are expected to do in order to maintain your compactor properly. This section will tell you how to clean and care for your compactor.

Cleaning

Before cleaning the compactor, turn the Key-Knob (or Key-Switch) to the OFF & LOCK position and remove it.

NOTE: Any services other than those outlined in this section should be performed by a designated service representative.

Cleaning Exterior Surfaces

1. Wash exterior surfaces (including stainless steel) with a clean sponge or soft cloth and a mild detergent in warm water. Do not use abrasive or harsh cleaners. Rinse and dry thoroughly with a soft cloth.
2. Wipe up spills right away. Some foods can damage the finish if left on the compactor surface.

Cleaning Inside the Drawer

NOTE: You may want to wear protective gloves as there may be bits of glass in the drawer.

1. Remove the bag. (See the "Removing a Filled Bag" section.)
2. Press down on the lever-action lock (or Side-Lock latch).

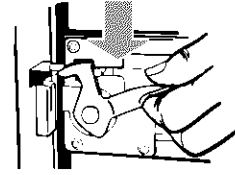

3. Hold the lever-action lock down and tilt the side of the drawer out until the lock clears the drawer front.

NOTE: If desired, the drawer side can be removed by tilting it up, then lifting it out.

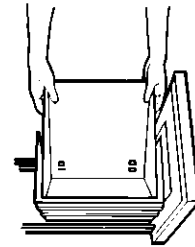

4. Wash the interior of the drawer with a clean sponge or soft cloth and a mild detergent in warm water. Rinse and dry thoroughly with a soft cloth.
5. If the drawer side was removed, slide it back into the tilted position.
6. Press the lever-action lock (or Side-Lock Latch) down while pushing the drawer side to the upright position.
7. Latch the drawer side by pushing up the lever-action lock (or Side-Lock Latch).

Cleaning Inside the Cabinet

NOTE: You may want to wear protective gloves as there may be bits of glass in the cabinet.

1. Pull the drawer out until it stops.

NOTE: Look to see how the drawer rollers move in the tracks. It will be easier to replace the drawer when you are finished cleaning.

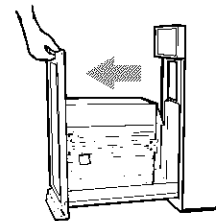

2. Lift the front of the drawer to clear the stops.

3. Grasp the drawer on the sides and pull it out the rest of the way. Set the drawer down gently.

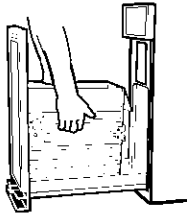

4. Vacuum the inside of the cabinet. Liquid spills or wet trash should be cleaned up by hand, or by using a vacuum designed to pick up liquids.

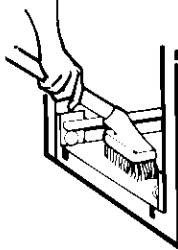

5. Wash the inside of the cabinet with a clean sponge or soft cloth and a mild detergent in warm water. Rinse and dry thoroughly with a soft cloth.
6. To replace the drawer, grasp it by the sides and insert the rollers onto the tracks.
7. Lift the front of the drawer and push it in fully past the stops.

Cleaning the Ram

NOTE: You may want to wear protective gloves as there may be bits of glass on the ram cover.

1. Wipe glass particles off of the ram cover with a cloth or paper towels.
2. Remove foods with a clean sponge or soft cloth and a mild detergent in warm water. Rinse and dry thoroughly with a soft cloth.

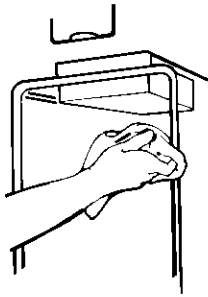

Cleaning before a vacation

If you will be away for more than a couple of days, remove the compactor bag. Remove the Key-Knob (or Key-Switch) and store it out of children's reach.

TROUBLESHOOTING

Try the solutions suggested here first in order to avoid the cost of an unnecessary service call.

Trash is not compacting

- **Is the drawer less than half full?** Drawer must be more than half full before trash is compacted.

Your compactor won't operate

- **Is the power supply cord unplugged?** Plug into a grounded 3 prong outlet.
- **Has a household fuse or circuit breaker tripped?** Replace the fuse or reset the circuit breaker.
- **Is the drawer completely closed?** Close the drawer firmly and start the compactor again.
- **Is the Key-Knob turned all the way to START?** Turn the Key-Knob (Key-Switch) fully to START and release (on some models). See the "Starting the Compactor" section.
- **Did you press ON before pressing START?** Press ON before pressing START (on some models). See the "Starting the Compactor" section.

The drawer won't open

- **Is the ram all the way up?** Drawer will open only when ram is fully raised.
- **To raise the ram on models with a Key-Knob (or Key-Switch):** Turn the Key-Knob (Key-Switch) to START and release. See the "Starting the Compactor" section.
- **To raise the ram on models with push button controls:** Press OFF, and then press ON. See the "Starting the Compactor" section.

There is not enough compaction or force

- **Do you use the compacting cycle frequently enough?** Compacting works best when only a few items are loaded.

Bottles don't break

- **How often do you notice this?** Bottles will not break every time. The thickness of the bottle's glass and the content of the trash load below it may prevent the bottle from breaking.

ASSISTANCE OR SERVICE

Before calling for assistance or service, please check "Troubleshooting." It may save you the cost of a service call. If you still need help, follow the instructions below.

When calling, please know the purchase date and the complete model and serial number of your appliance. This information will help us to better respond to your request.

If you need replacement parts

If you need to order replacement parts, we recommend that you only use FSP® replacement parts. FSP® replacement parts will fit right and work right because they are made with the same precision used to build every new WHIRLPOOL® appliance.

To locate FSP® replacement parts in your area, call our Customer Interaction Center telephone number or your nearest designated service center.

In the U.S.A.

Call the Whirlpool Customer Interaction Center toll free: **1-800-253-1301**.

Our consultants provide assistance with:

- Features and specifications on our full line of appliances.
- Installation information.
- Use and maintenance procedures.
- Accessory and repair parts sales.
- Specialized customer assistance (Spanish speaking, hearing impaired, limited vision, etc.).
- Referrals to local dealers, repair parts distributors, and service companies. Whirlpool designated service technicians are trained to fulfill the product warranty and provide after-warranty service, anywhere in the United States.

To locate the Whirlpool designated service company in your area, you can also look in your telephone directory Yellow Pages.

For further assistance

If you need further assistance, you can write to Whirlpool Corporation with any questions or concerns at:

Whirlpool Brand Home Appliances
Customer Interaction Center
553 Benson Road
Benton Harbor, MI 49022-2692

Please include a daytime phone number in your correspondence.

In Canada

Call the Whirlpool Canada Customer Interaction Center toll free: **1-800-461-5681** 8:30 a.m. - 5:30 p.m. (EST)

Our consultants provide assistance with:

- Features and specifications on our full line of appliances.
- Referrals to local dealers.

For service in Canada

Call **1-800-807-6777**. Whirlpool Canada designated service technicians are trained to fulfill the product warranty and provide after-warranty service, anywhere in Canada.

For further assistance

If you need further assistance, you can write to Whirlpool Canada with any questions or concerns at:

Customer Interaction Center
Whirlpool Canada
1901 Minnesota Court
Mississauga, Ontario L5N 3A7

Please include a daytime phone number in your correspondence.

Accessories

To ensure the proper functioning of your compactor, use FSP® replacement parts only. To order replacement parts or accessories, call **1-800-253-1301** and ask for the appropriate part number listed below or contact your authorized Whirlpool dealer. In Canada, call **1-800-461-5681**.

Replacement Bags - Call for Part Number

Trim Kits for Custom Front Panels:

Order Part #9871381 (Brushed stainless steel)

Order Part #9871382 (White)

Order Part #9871383 (Black)

Order Part #9871384 (Almond)

Order Part #9871600 (Biscuit)

See section "Changing the Decorative Panel" for custom panel dimensions.

Notes

Notes

WHIRLPOOL® COMPACTOR WARRANTY

ONE-YEAR FULL WARRANTY ON COMPACTOR

For one year from the date of purchase, when this compactor is operated and maintained according to instructions attached to or furnished with the product, Whirlpool Corporation will pay for FSP® replacement parts and repair labor costs to correct defects in materials or workmanship. Service must be provided by a Whirlpool designated service company.

Whirlpool Corporation will not pay for:

1. Service calls to correct the installation of your compactor, to instruct you how to use your compactor, or to replace house fuses or correct house wiring.
 2. Repairs when your compactor is used in other than normal, single-family household use.
 3. Pickup and delivery. Your compactor is designed to be repaired in the home.
 4. Damage resulting from accident, alteration, misuse, abuse, fire, flood, improper installation, acts of God, or use of products not approved by Whirlpool Corporation.
 5. Repairs to parts or systems resulting from unauthorized modifications made to the appliance.
 6. Replacement parts or repair labor costs for units operated outside the United States or Canada.
 7. Charcoal Filters.
 8. In Canada, travel or transportation expenses for customers who reside in remote areas.
-

WHIRLPOOL CORPORATION AND WHIRLPOOL CANADA SHALL NOT BE LIABLE FOR INCIDENTAL OR CONSEQUENTIAL DAMAGES

Some states or provinces do not allow the exclusion or limitation of incidental or consequential damages, so this exclusion or limitation may not apply to you. This warranty gives you specific legal rights, and you may also have other rights which vary from state to state or province to province.

Outside the 50 United States and Canada, this warranty does not apply. Contact your authorized Whirlpool dealer to determine if another warranty applies.

If you need service, first see the "Troubleshooting" section of this book. After checking "Troubleshooting," additional help can be found by checking the "Assistance or Service" section or by calling the Whirlpool Customer Interaction Center, 1-800-253-1301 (toll-free), from anywhere in the U.S.A. In Canada, contact your Whirlpool Canada Appliance designated service company or call 1-800-807-6777.

9/01

Keep this book and your sales slip together for future reference. You must provide proof of purchase or installation date for in-warranty service.

Write down the following information about your compactor to better help you obtain assistance or service if you ever need it. You will need to know your complete model number and serial number. You can find this information on the model and serial number label located on the inside wall of the compactor drawer.

Dealer name _____

Address _____

Phone number _____

Model number _____

Serial number _____

Purchase date _____

9871676B

© 2001 Whirlpool Corporation.
All rights reserved.

® Registered Trademark/TM Trademark of Whirlpool, U.S.A.
Whirlpool Canada licensee in Canada

9/01
Printed in U.S.A.

