

Save This Manual  
For Future Reference

**SEARS**

**owners  
manual**

**MODEL NO.  
113.247440**

**ELECTRONIC BAND SAW  
WITH LEG SET**

Serial  
Number \_\_\_\_\_  
Model and serial numbers  
may be found at the  
left-hand side of the base.  
You should record both  
model and serial number  
in a safe place for future  
use.

**CAUTION:**

**READ ALL  
INSTRUCTIONS  
CAREFULLY**

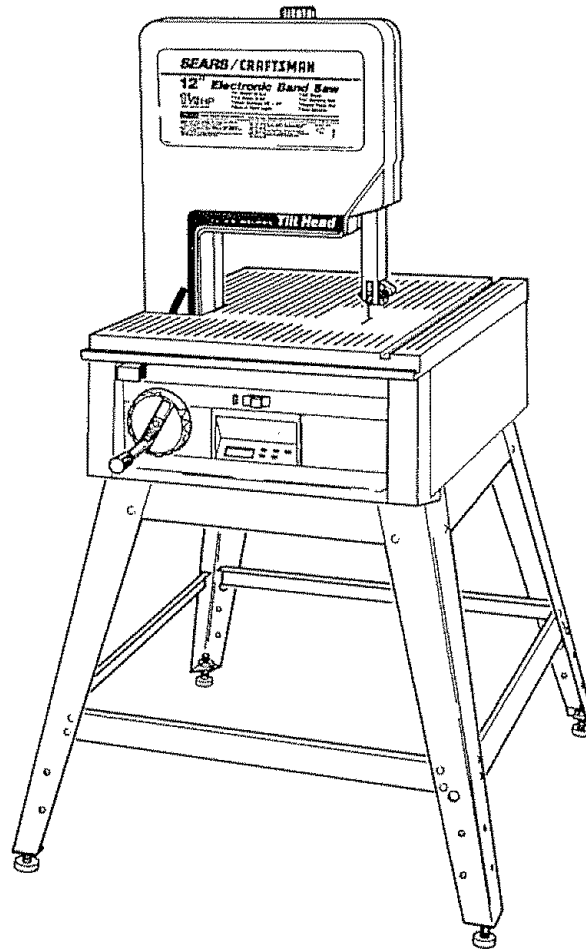

**SEARS / CRAFTSMAN®**

## **12-INCH ELECTRONIC BAND SAW**

- assembly
- operating
- repair parts

Sold by SEARS, ROEBUCK AND CO., Chicago, IL. 60684 U.S.A.

## FULL ONE YEAR WARRANTY ON CRAFTSMAN BAND SAW

If within one year from the date of purchase, this Craftsman Band Saw fails due to a defect in material or workmanship, Sears will repair it, free of charge.

WARRANTY SERVICE IS AVAILABLE BY SIMPLY CONTACTING THE NEAREST SEARS SERVICE CENTER/DEPARTMENT THROUGHOUT THE UNITED STATES.

This warranty applies only while this product is used in the United States.

This warranty gives you specific legal rights and you may also have other rights which vary from state to state.

SEARS, ROEBUCK AND CO., DEPT. 698/731A Sears Tower, Chicago, IL 60684

# GENERAL SAFETY INSTRUCTIONS FOR POWER TOOLS

## 1. KNOW YOUR POWER TOOL

Read and understand the owner's manual and labels affixed to the tool. Learn its application and limitations as well as the specific potential hazards peculiar to this tool.

## 2. GROUND ALL TOOLS

This tool is equipped with an approved 3-conductor cord and a 3-prong grounding type plug to fit the proper grounding type receptacle. The green conductor in the cord is the grounding wire. Never connect the green wire to a live terminal.

## 3. KEEP GUARDS IN PLACE,

in working order, and in proper adjustment and alignment.

## 4. REMOVE ADJUSTING KEYS AND WRENCHES

Form habit of checking to see that keys and adjusting wrenches are removed from tool before turning it on.

## 5. KEEP WORK AREA CLEAN

Cluttered areas and benches invite accidents. Floor must not be slippery due to wax or sawdust.

## 6. AVOID DANGEROUS ENVIRONMENT

Don't use power tools in damp or wet locations or expose them to rain. Keep work area well lighted. Provide adequate surrounding work space.

## 7. KEEP CHILDREN AWAY

All visitors should be kept a safe distance from work area.

## 8. MAKE WORKSHOP CHILD-PROOF

— with padlocks, master switches, or by removing starter keys.

## 9. DON'T FORCE TOOL

It will do the job better and safer at the rate for which it was designed.

## 10. USE RIGHT TOOL

Don't force tool or attachment to do a job it was not designed for.

## 11. WEAR PROPER APPAREL

Do not wear loose clothing, gloves, neckties or jewelry (rings, wrist watches) to get caught in moving parts. Nonslip footwear is recommended. Wear protective hair covering to contain long hair. Roll long sleeves above the elbow.

## 12. USE SAFETY GOGGLES (Head Protection)

Wear Safety goggles (must comply with ANSI

Z87.1) at all times. Everyday eyeglasses only have impact resistant lenses, they are NOT safety glasses. Also, use face or dust mask if cutting operation is dusty, and ear protectors (plugs or muffs) during extended periods of operation.

## 13. SECURE WORK

Use clamps or a vise to hold work when practical. It's safer than using your hand, and frees both hands to operate tool.

## 14. DON'T OVERREACH

Keep proper footing and balance at all times.

## 15. MAINTAIN TOOLS WITH CARE

Keep tools sharp and clean for best and safest performances. Follow instructions for lubricating and changing accessories.

## 16. DISCONNECT TOOLS

before servicing; when changing accessories such as blades, bits, cutters, etc.

## 17. AVOID ACCIDENTAL STARTING

Make sure switch is in "OFF" position before plugging in.

## 18. USE RECOMMENDED ACCESSORIES

Consult the owner's manual for recommended accessories. Follow the instructions that accompany the accessories. The use of improper accessories may cause hazards.

## 19. NEVER STAND ON TOOL

Serious injury could occur if the tool is tipped or if the cutting tool is accidentally contacted. Do not store materials above or near the tool such that it is necessary to stand on the tool to reach them.

## 20. CHECK DAMAGED PARTS

Before further use of the tool, a guard or other part that is damaged should be carefully checked to ensure that it will operate properly and perform its intended function. Check for alignment of moving parts, binding of moving parts, breakage of parts, mounting, and any other conditions that may effect its operation. A guard or other part that is damaged should be properly repaired or replaced.

## 21. NEVER LEAVE TOOL RUNNING UNATTENDED

Turn power off. Don't leave tool until it comes to a complete stop.

# additional safety instructions for band saw

Safety is a combination of common sense, staying alert, and knowing how your band saw works.

## BEFORE USING THE SAW:

**WARNING: TO AVOID MISTAKES THAT COULD RESULT IN SERIOUS, PERMANENT INJURY, DO NOT PLUG THE SAW IN UNTIL THE FOLLOWING STEPS HAVE BEEN SATISFACTORILY COMPLETED:**

1. Assembly and alignment.
2. Learn the function and proper use of the on-off switch, bevel crank and lock, upper blade guide

and lock knob, lower blade guide, tension adjusting knob and tension scale, and blade thrust bearing adjustment.

3. Read and understand all safety instructions and operating procedures throughout the manual.
4. Read the following labels which appear on the front of the band saw and blade guard.



## SEARS / CRAFTSMAN

---

# 12" Electronic Band Saw

### 1 1/8 HP

MAX DEVELOPED

- 6" Depth of Cut
- Tilt Blade 0-45°
- Work Surface 23" x 27"
- Built-in Work Light

- 80" Blade
- 1/2" Sanding Belt
- Digital Read Out
- Two Speeds

**DANGER** FOR YOUR OWN SAFETY: Know This Tool! Read and Understand Owner's Manual before Using this Machine.

<ul style="list-style-type: none"><li>* Always wear safety goggles that comply with ANSI Z87.1</li><li>* Before turning saw on, check and adjust:<ul style="list-style-type: none"><li>a) Blade Tension</li><li>b) Blade Guide</li><li>c) Thrust Bearings</li></ul></li><li>* Before turning saw on, adjust UPPER BLADE GUIDE to just clear workpiece</li><li>* Support, fixture or brace workpiece firmly against table so it will not rock or twist from your hand.</li></ul>	<ul style="list-style-type: none"><li>* Plan hand position so a sudden slip won't cause injury.</li><li>* Turn saw off and wait for blade to stop before feeding jammed material.</li><li>* Turn saw off, remove switch key, and wait for blade to stop before adjusting saw, changing blades or leaving area.</li><li>* Maintain 1/8" maximum clearance between table and sanding belt.</li></ul>	<p><b>ELECTRICAL RATINGS</b></p> <ul style="list-style-type: none"><li>• 120 VOLTS</li><li>• 30 AC</li><li>• 7.0 AMP</li></ul>
---	--	--

## WHEN INSTALLING OR MOVING THE SAW

1. To avoid injury from unexpected saw movement:
  - a. Place the saw on a firm level surface where there is plenty of room for feeding the workpiece
  - b. Adjust the saw so the table is level and the saw does not rock
  - c. Bolt the saw to the floor if it tends to slip, slide, or tip over during operations like cutting long, heavy boards
  - d. Turn saw off and unplug electric cord before moving the saw to a new area
2. Store and use the band saw indoors.

## BEFORE EACH USE

1. Inspect your saw. If any part of this band saw is missing, or bent, or failed in any way, or any electrical components do not work properly, turn the saw off, remove switch key, and unplug the saw. Replace damaged, missing, or failed parts before using the saw again.
2. Plan your work to protect your eyes, hands, face, ears and body

- a. Do not do layout, assembly, or set up work on the table while the saw is running.
- b. Wear safety goggles (not glasses) that comply with ANSI Z87.1 (shown on package) Using any power tool can result in foreign objects being thrown into the eyes, which can result in permanent eye damage. Safety goggles are



available at Sears retail or catalog stores. Use of glasses or use of goggles not in compliance with ANSI Z87.1 could result in severe injury from breakage of the eye protection

- c. For dusty operations, wear a face shield along with safety goggles.
- d. Use extra caution with large, very small, or awkward workpieces.
  1. Use extra supports (tables, saw horses, etc.) for any workpieces large enough to tip when not held down to the table top.

# additional safety instructions

2. Do not feed small pieces that require your finger holding the workpiece to go under the guard area. Use jigs or fixtures to hold the work and keep your hands away from the blade
3. When cutting irregularly shaped workpieces, plan your work so it will not pinch the blade. A piece of molding, for example, must lay flat or be held by a fixture or jig that will not let it twist, rock or slip while being cut.
4. Properly support round material such as dowel rods, or tubing. They have a tendency to roll while being cut, causing the blade to "bite." To avoid this, always use a "V" block, or clamp the workpiece to a miter gage
- e. To avoid risk of hearing damage, wear ear plugs or muffs during extended periods of operation.
- f. To avoid being suddenly caught in the blade:
  1. Do not wear gloves
  2. Remove all jewelry and loose clothing.
  3. Tie back long hair.
  4. Roll long sleeves above the elbow.
- g. To avoid injury from accidental starting, always unplug saw, turn switch off and remove switch key before removing the guard, installing or removing any blade, accessory or attachment, or making any adjustments.
- h. To avoid slips and jams causing injury:
  1. Choose the right size and style blade for the material and the type of cutting you plan to do. Use this band saw to cut and sand only wood, wood like products and plastic
  2. Make sure the blade teeth point downward toward the table
  3. Make sure the blade tracking guides and thrust bearings are properly adjusted
  4. Always check and correctly adjust blade or sanding belt tension.
- i. To avoid accidental blade contact, minimize blade breakage and provide maximum blade support
  1. Always adjust the upper blade guide and blade guard to just clear the workpiece.
  2. Plan your hand placement so your fingers will not be where a sudden slip could cause them to hit the blade
- j. Make sure all clamps and locks are tight and there is no excessive play in any parts.
- k. To avoid an electrical shock, make sure your fingers do not touch the metal prongs on the plug when installing or removing the plug to or from a live outlet.

- l. Never turn your band saw "ON" before clearing everything except the workpiece and related feed or support devices off the table

## BEFORE SANDING

1. Keep the table and sanding belt adjusted so the gap between them is no more than 1/16-inch wide
2. To avoid fire, shock, or cause electrical shorts, do not sand metal. It could ignite the sawdust inside the saw

## WHENEVER SAW IS RUNNING

**WARNING: DO NOT ALLOW FAMILIARITY (GAINED FROM FREQUENT USE OF YOUR BAND SAW) TO CAUSE A CARELESS MISTAKE. ALWAYS REMEMBER THAT A CARELESS FRACTION OF A SECOND IS SUFFICIENT TO INFLICT SEVERE INJURY.**

- a. If your saw makes unfamiliar noise or if it vibrates excessively, stop immediately. Turn the saw off, remove switch key and unplug the saw. Do not restart until finding and correcting the problem.
- b. Avoid awkward hand positions where a sudden slip could cause a hand to move into the blade or the sanding belt.
- c. Feed the workpiece only fast enough to let the blade cut without bogging down or binding.
- d. Before freeing jammed material, turn saw off. Remove switch key. Remove plug from power source outlet. Wait for all moving parts to stop.
- e. When backing up the workpiece, the blade may bind in the kerf (cut). This is usually caused by sawdust clogging up the kerf or because the blade comes out of the guides. If this happens:
  1. Turn saw off.
  2. Unplug saw.
  3. Remove switch key.
  4. Wait for all moving parts to stop.
  5. Remove band saw cover.
  6. Stick a flat blade screwdriver or wedge into the kerf.
  7. Turn the upper wheel by hand while backing up the workpiece.
- f. Before removing loose pieces from the table, turn saw off and wait for all moving parts to stop.

## ACCESSORIES

To avoid injury from untested or improper accessories, use only Recommended Accessories listed on the Accessory page of this manual.

# table of contents

	Page		Page
General Safety Instructions for Power Tools	2	Location and Function of the Electronic	
Additional Safety Instructions for Band Saw	3	Indicator System	17
Before Using the Saw	3	Digital Readout Display	17
When Installing or Moving the Saw	3	Function Keys	17
Before Each Use	3	Battery Cover	17
Before Sanding	4	Using the Electronic Indicator System	18
Whenever Saw is Running	4	Installing the Blade	19
Accessories	4	Aligning the Blade and Blade Guides	20
Glossary of Terms for Woodworking	5	Mounting the Front Table	22
Electrical Connections	6	Squaring the Blade to the Table	24
Power Supply	6	Location and Function of Controls	25
Motor Safety Protection	6	On-Off Switch	25
Wire Sizes	7	Tilting Head for Bevel Cut	25
Unpacking and Checking Contents	7	Adjusting Bevel Lock Knob	25
Tools Needed	7	Basic Band Saw Operation	26
Table of Loose Parts	8	Circle Cutting	26
Loose Parts Bags	9	Sawdust Collection	26
Assembly and Alignment	10	Installing Sanding Attachment	27
Assembling Leg Set	10	Installing the Sanding Belt	27
Mounting the Motor	11	Recommended Accessories	28
Selecting Blade Speed	14	Maintenance	29
Recommended Speed Settings	14	Adjusting Band Saw Bevel Travel	29
Mounting the Saw to the Leg Set	14	Adjusting Upper Blade Guide Travel	29
Attaching Trim Caps and Trim Ledge	15	Trouble Shooting	30
Attaching Handwheel	15	Repair Parts	34
Getting to Know Your Band Saw	16		

## glossary of terms for woodworking

### Beveling

An angle cutting operation through the face of the board

### Crosscut

A cutting operation made across the width of the workpiece.

### Compound Cutting

A simultaneous bevel and miter cutting operation.

### FPM

Feet per minute. Used in reference to surface speed of blade

### Freehand (as used for band saw)

Performing a cut without the workpiece properly supported on the work table

### Gum

A sticky, sap based residue from wood products.

### Kerf

The material removed by the blade in a through cut or the slot produced by the blade in a non-through or partial cut

### Leading End

The end of the workpiece which is pushed into the cutting tool first

### Mitering

An angle cutting operation made across the width of the workpiece

### Push Stick

A device used to feed the workpiece through the saw during narrow ripping type operations so the operator's hands are kept well away from the blade.

### Resaw

A cutting operation to reduce the thickness of the workpiece to make thinner pieces

### Resin

A sticky, sap based substance that has dried.

### Ripping

A cutting operation along the length of the workpiece

### Sawblade Path

The area of the worktable or workpiece directly in line with the saw blade.

### Set

The distance the tip of the saw blade tooth is bent outward from the face of the blade.

### Trailing End

The workpiece end last cut by the saw blade.

### Workpiece

The item on which the cutting operation is being performed. The surfaces of a workpiece or commonly referred to as faces, ends, and edges.

### Worktable

The surface on which the workpiece rests while performing a cutting or sanding operation.

# electrical connections

## POWER SUPPLY

### Motor Specifications

The AC motor used in this saw is a capacitor-start, non-reversible type having the following specifications:

Rated H.P.	5/8
Maximum Developed H.P.	1-1/8
Voltage	120
Amperes	7.9
Hertz (Cycles)	60
Phase	Single
RPM	1725
Rotation of Shaft	Clockwise

**WARNING: TO AVOID ELECTRICAL HAZARDS, FIRE HAZARDS, OR DAMAGE TO THE TOOL, USE PROPER CIRCUIT PROTECTION. YOUR SAW IS WIRED AT THE FACTORY FOR 120V OPERATION. CONNECT TO A 120V, 15-AMP, BRANCH CIRCUIT AND USE A 15-AMP FUSE OR CIRCUIT BREAKER. TO AVOID SHOCK OR FIRE, IF POWER CORD IS WORN OR CUT, OR DAMAGED IN ANY WAY, HAVE IT REPLACED IMMEDIATELY.**

**IF NOT PROPERLY GROUNDED THIS POWER TOOL CAN CAUSE ELECTRICAL SHOCK — PARTICULARLY WHEN USED IN DAMP LOCATIONS CLOSE TO PLUMBING. IF AN ELECTRICAL SHOCK OCCURS THERE IS ALSO THE POTENTIAL OF A SECONDARY HAZARD SUCH AS YOUR HANDS CONTACTING THE SAWBLADE. NOT ALL OUTLETS ARE PROPERLY GROUNDED. IF YOU ARE NOT SURE THAT YOUR OUTLET IS PROPERLY GROUNDED, HAVE IT CHECKED BY A QUALIFIED ELECTRICIAN.**

Your unit has a plug that looks like the one shown below

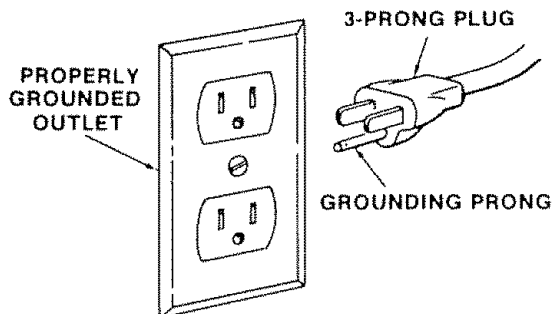

This power tool is equipped with a 3-conductor cord and ground type plug listed by Underwriters' Laboratories. The ground conductor has a green jacket and is attached to the tool housing at one end and to the ground prong in the attachment plug at the other end

This plug requires a mating 3-conductor grounded type outlet as shown above.

**WARNING: TO MAINTAIN PROPER TOOL GROUNDING WHENEVER THE OUTLET YOU ARE PLANNING TO USE FOR THIS POWER TOOL IS OF THE TWO PRONG TYPE, DO NOT REMOVE OR ALTER THE GROUNDING PRONG IN ANY MANNER.**

It is recommended that you have a qualified electrician replace the two prong outlet with a properly grounded three prong outlet.

## MOTOR SAFETY PROTECTION

**CAUTION: To avoid motor damage this motor should be blown out or vacuumed frequently to keep sawdust from interfering with normal motor ventilation.**

1. This tool should be connected to a 120V, 15 amp branch circuit with a 15 amp fuse or circuit breaker. Failure to use the proper size fuse can result in damage to the motor.
2. If the motor fails to start, turn the power switch to the "OFF" position immediately. UNPLUG THE TOOL. Check the saw blade to make sure it turns freely. If the blade is free, try to start the motor again. If the motor still does not start, refer to the "Motor Trouble-Shooting Chart."
3. If the motor suddenly stalls while cutting wood, turn the power switch off, unplug the tool, and free the blade from the wood. The motor may now be restarted and the cut finished.
4. Frequent "blowing" of fuses or tripping of circuit breakers may result if:
  - a. MOTOR IS OVERLOADED - Overloading can occur if you feed too rapidly.
  - b. LOW VOLTAGE - Although the motor is designed for operation on the voltage and frequency specified on the motor nameplate, normal loads will be handled safely on voltages not more than 10% above or below the nameplate voltage. Heavy loads, however, require that voltage at motor terminals equals the voltage specified on nameplate.

- Most motor troubles may be traced to loose or incorrect connections, overload, reduced input voltage (such as small size wire in the supply circuit) or to overly long supply circuit wire. Always check the connections, the load and the supply circuit whenever motor fails to perform satisfactorily. Check wire size and length with the Wire Size Chart below.

## WIRE SIZES

The use of any extension cord will cause some loss of power. To keep this to a minimum and to prevent overheating and motor burn-out, use the table below to determine the minimum wire size (A.W.G.) extension cord. Use only 3-wire extension cords which have 3-prong grounding type plugs and 3-pole receptacles which accepts the tools plug

**CAUTION: For circuits that are farther away from electrical service box, the wire size must be increased proportionately in order to deliver ample voltage to the saw motor.**

Length of the Conductor	120 Volts Wire Sizes Required (American Wire Gage Number)
0 - 25 Ft.	16
26 - 50 Ft.	14
51 - 100 Ft.	12

## unpacking and checking contents

### TOOLS NEEDED

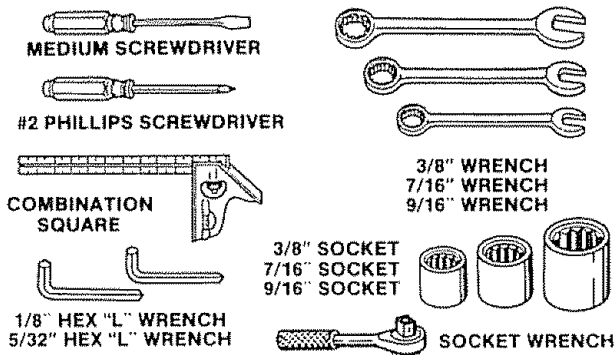

COMBINATION SQUARE MUST BE TRUE

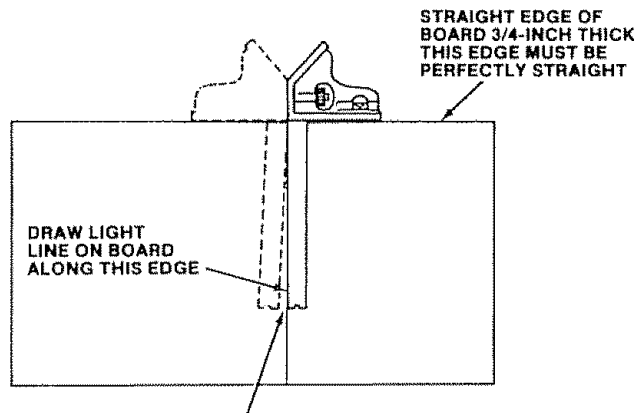

SHOULD BE NO GAP OR OVERLAP HERE WHEN SQUARE IS FLIPPED OVER IN DOTTED POSITION

**WARNING: TO AVOID INJURY FROM UNEXPECTED STARTING OR ELECTRICAL SHOCK, DO NOT PLUG THE SAW IN UNTIL ALL ASSEMBLY AND ALIGNMENT STEPS ARE COMPLETE. THE POWER CORD MUST REMAIN UNPLUGGED WHENEVER YOU ARE WORKING ON THE SAW.**

### Unpacking and Checking Contents

- Separate all "loose parts" from packaging materials and check each item with "Table of Loose Parts" to make sure all items are accounted for, before discarding any packing material.

**WARNING: IF ANY PARTS ARE MISSING, DO NOT ATTEMPT TO ASSEMBLE THE BAND SAW, PLUG IN THE POWER CORD, OR TURN THE SWITCH ON UNTIL THE MISSING PARTS ARE OBTAINED AND ARE INSTALLED CORRECTLY.**

- Remove front table and front cover first while saw is being unpacked. To remove the front cover, pull the cover at the neck and underside of throat area.

# unpacking and checking contents

## TABLE OF LOOSE PARTS

Model 113.247440 Electronic Band Saw comes complete in one carton and includes steel legs

ITEM	DESCRIPTION	QTY.
AA	Motor	1
BB	Basic Saw Assembly	1
CC	Owners Manual	1
DD	Leg	4
EE	Stiffener, Upper	4
FF	Stiffener, Lower	4
GG	Trim Cap, L.H.	1
HH	Trim Cap, R.H.	1
JJ	Trim Ledge	1
KK	Loose Parts Bag containing the following items:	
	Band Saw Blade	1
	Sanding Belt 1/2 x 80	1
	Handwheel Assembly	1
	Bag of Loose Parts #507655	1
	Bag of Loose Parts #507657	1
	Bag of Loose Parts #507741	1
	Battery	1

**NOTE:** To avoid damage to the band saw leave it laying on its left side until you are ready to mount it to the leg set or cabinet. To prevent scratching the finish, lay a piece of the packing box under the saw.

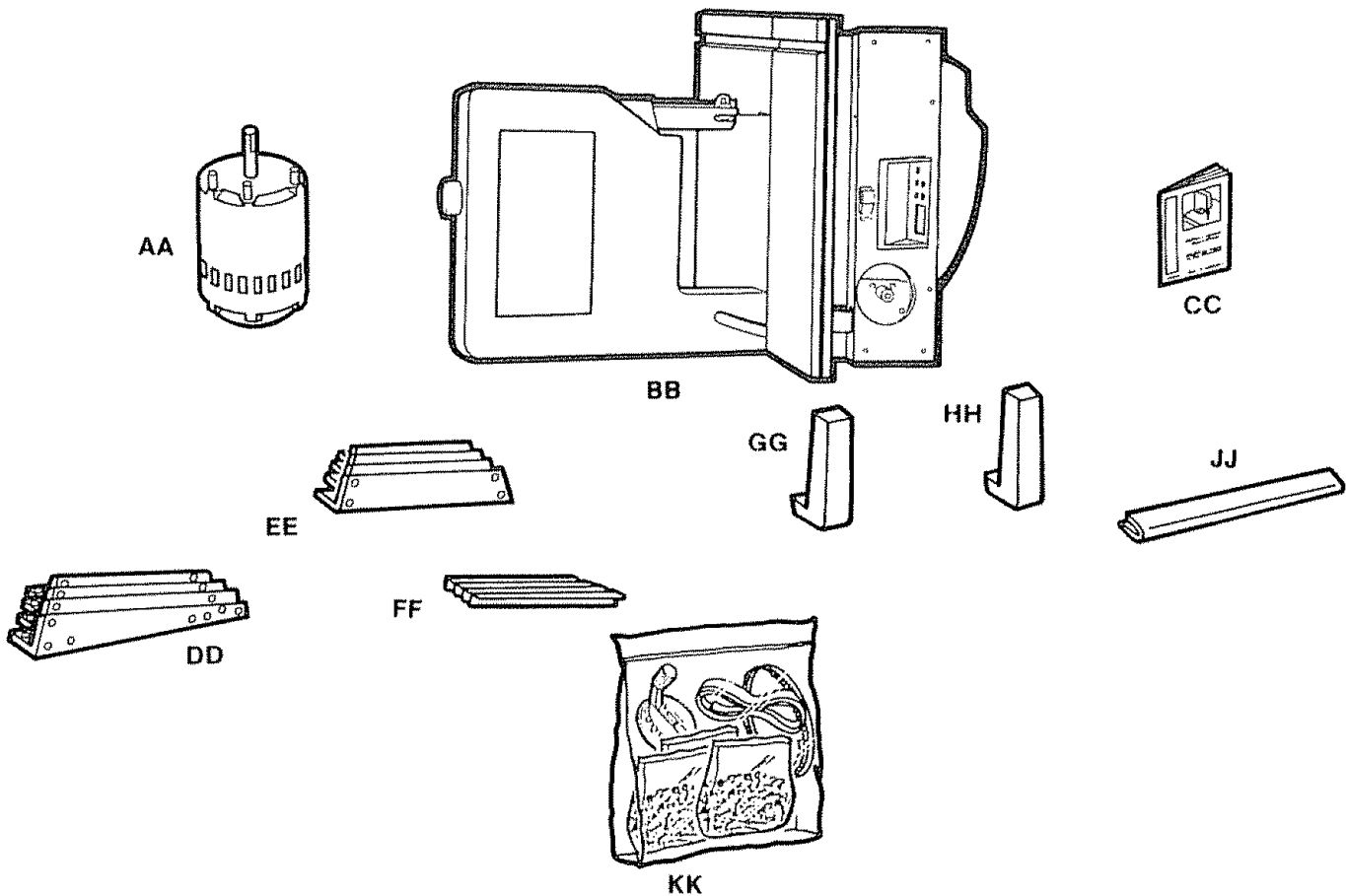

**LIST OF LOOSE PARTS IN BAG #507657**

ITEM	DESCRIPTION	QTY.
A	Truss Head Screw 1/4-20 x 1/2	44
B	Lockwasher Ext. 1/4	44
C	Hex Nut 1/4-20	44
D	Leveling Foot	4
E	Hex Jam Nut 3/8-16	8

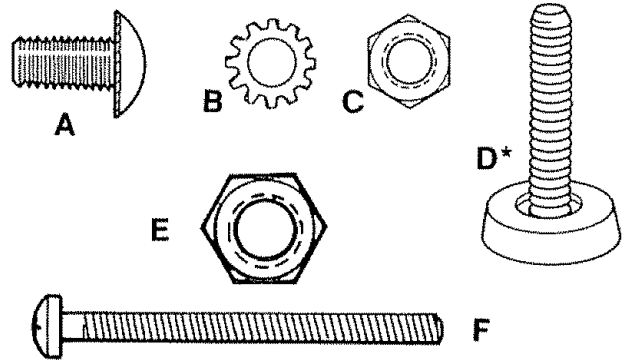

**LIST OF LOOSE PARTS IN BAG #507655**

ITEM	DESCRIPTION	QTY.
F	Pan Hd. Screw 10-32 x 2	1
G	Hex Nut 10-32	1
H	Switch Key	1
I	Lo Hd. Screw Cap 1/4-20 x 5/8	2
J	Spacer #10 x 5/16	3
K	Hex Flange Lock Nut 10-32	4
L	Locking Setscrew 1/4-20 x 1/2	3
M	Wingnut 5/16-18	1
N	Pan Hd. Screw 1/4-20 x 5/8	2
B	Lockwasher Ext. 1/4	2
C	Hex Nut 1/4-20	2
O	Hex Hd. Screw Ty TT 1/4-20 x 5/8	4
P	Pan Hd. Screw Ty BT 1/4 x 1/2	6

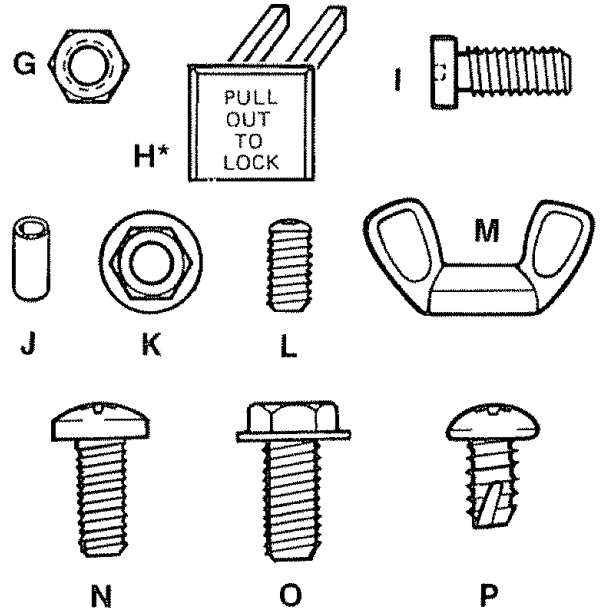

**LIST OF LOOSE PARTS IN BAG #507741**

ITEM	DESCRIPTION	QTY.
R	Sanding Platen	1
S	Table Alignment Key	1
T	Table Latch	2
U	Belt Tension Stud	1
V	Poly "V" Belt	1
W	Poly "V" Pulley	1
X	Table Latch Spring	2
Y	Table Alignment Spring	2
Z	Key 3/16 Sq. x 15/16	1

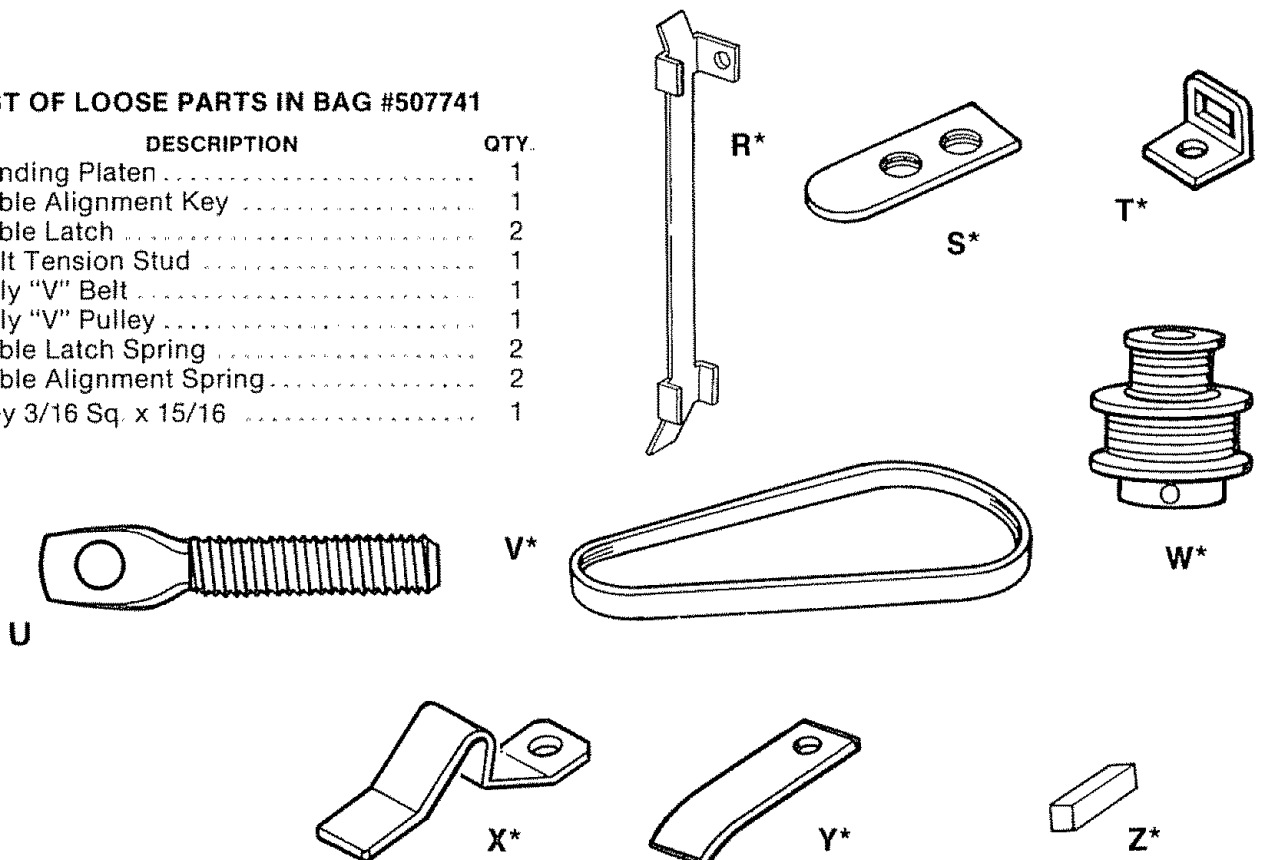

\*NOT SHOWN TO SCALE

# assembly and alignment

## ASSEMBLING LEG SET

From the loose parts bag find the following hardware:

ITEM	DESCRIPTION	QTY.
A	Truss Head Bolts 1/4-20 x 1/2	40
B	Lock Washers Ext. 1/4	40
C	Hex Nuts 1/4-20	40
D	Leveling Feet	4
E	Hex Nut 3/8-16	8

From the loose parts find the following items:

ITEM	DESCRIPTION	QTY.
DD	Legs	4
EE	Upper stiffeners	4
FF	Lower stiffeners	4

Assemble the Leg Set as follows:

1. Attach the four (4) legs to the four (4) upper stiffeners as shown. Three (3) bolts, washers, and nuts are required to fasten each end of upper stiffener to a leg. Hand tighten hex nuts.
2. Attach the four (4) lower stiffeners to the legs. Two (2) bolts, washers and nuts are required to hold each end of a lower stiffener in place. Hand tighten hex nuts.

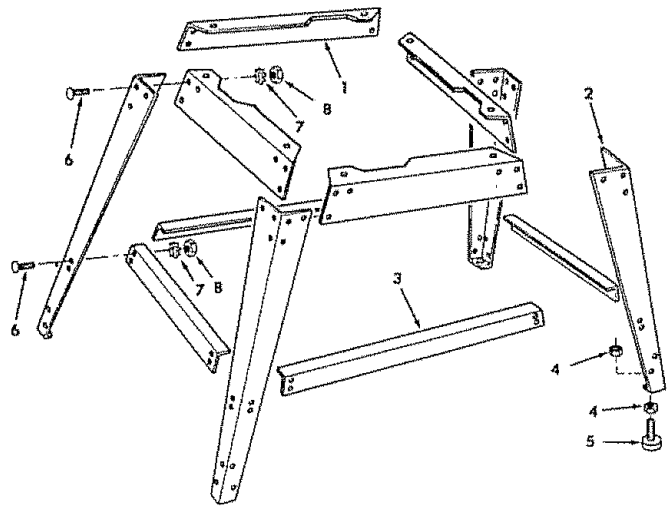

3. Attach four (4) leveling feet to bottom of each leg as illustrated. Hand tighten hex nuts.
4. Put leg set in area intended for use of saw. With a 7/16-inch wrench or socket, securely tighten all bolts. Adjust leveling feet.

**WARNING: TO AVOID INJURY FROM UNEXPECTED SAW OR WORK MOVEMENT, LEVELING FEET MUST BE ADJUSTED SO THAT SAW DOES NOT ROCK.**

To Adjust leveling feet so the saw will sit properly:

- a. Move saw to desired location.
- b. With 9/16-inch wrench loosen bottom nut.
- c. Back off top nut by hand.
- d. Raise or lower foot by adjusting bottom nut using 9/16-inch wrench.
- e. Snug top nut against inside of leg by hand.
- f. Adjust all four feet as necessary then tighten all four bottom nuts using a 9/16-inch wrench.

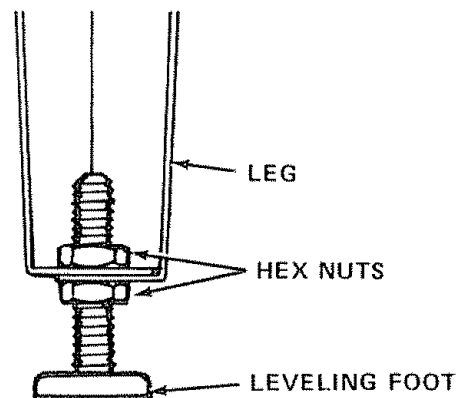

## MOUNTING THE MOTOR

1. Find the following parts:

ITEM	DESCRIPTION	QTY.
AA	Motor	1
J	Spacer (1/4 O D. x 5/16)	3
K	Flanged Locknut #10-32	4
M	Wing Nut 5/16-18	1
U	Belt Tension Stud	1
W	Motor Pulley w/Setscrew	1
V	Poly "V" Belt	1
Z	Key 3/16 Sq. x 15/16	1

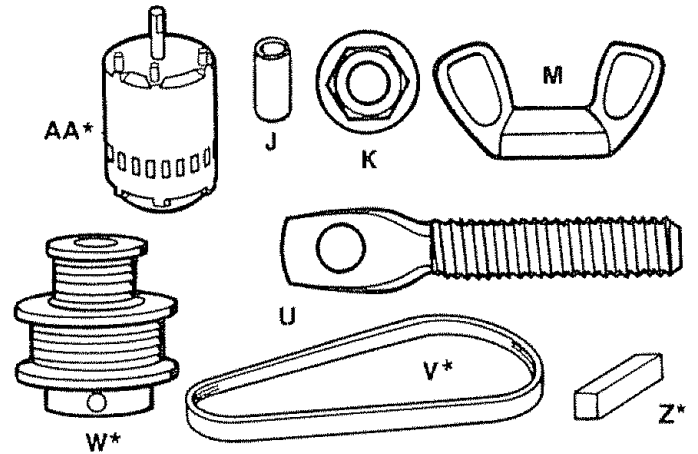

\*NOT SHOWN TO SCALE

- Have the band saw positioned on its left side as unpacked. To prevent scratching the finish, lay a piece of the packing box under the saw.
- Place the three (3) spacers onto the three motor studs as shown. Pay attention to where the oil plug is located. No spacer goes on the fourth motor stud.

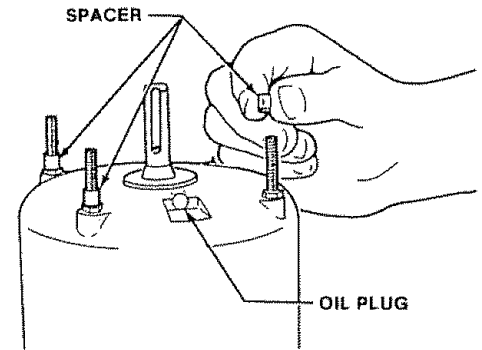

- Place the shaft key into the groove on the motor shaft. Align the groove in the pulley with the shaft key and install the motor pulley on the motor shaft with the setscrew toward the motor. The pulley has an internal shoulder that will position the pulley the correct distance on the motor shaft.

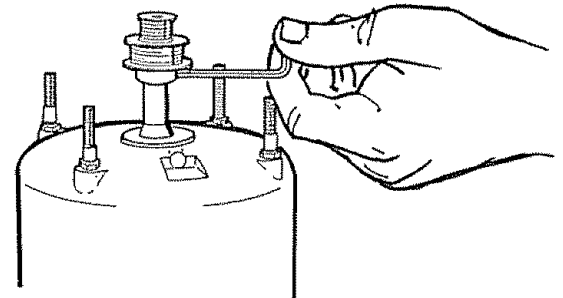

- Place the Poly "V" belt into the motor mount as shown on the underside of the band saw.
- Look at the motor mount and find the slot that is narrower than the other three. When mounting the motor, the motor stud without a spacer goes into this slot.

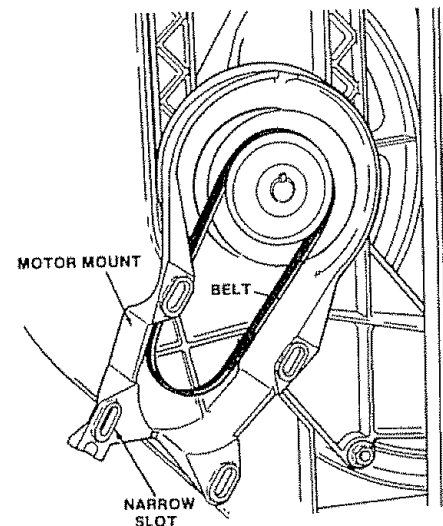

7. Carefully position the motor so that the poly "V" belt is around the motor pulley and the four motor studs align with the slots in the motor mount
8. Push motor studs through and install the flanged lock nuts to the three (3) motor studs with spacers. Start the flanged nuts by hand only at this time.

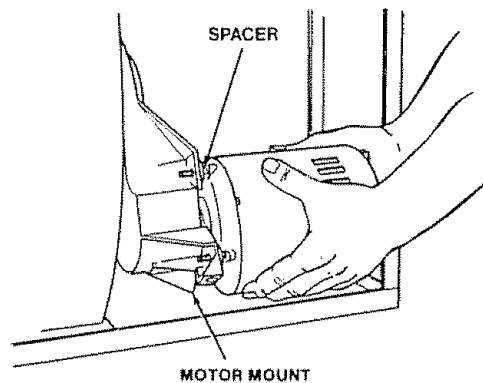

9. Install the threaded stud through the hole in the lower leg of the motor mount and over the motor stud as shown.

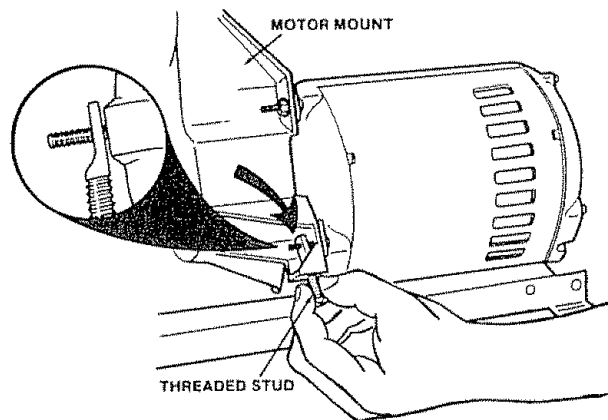

10. Install a flanged lock nut onto this motor stud. Tighten the flanged lock nuts, using a 3/8-inch wrench, until almost tight.

**NOTE:** Do not over-tighten the flange nuts. The motor should slide in the grooves to allow tensioning of the belt.

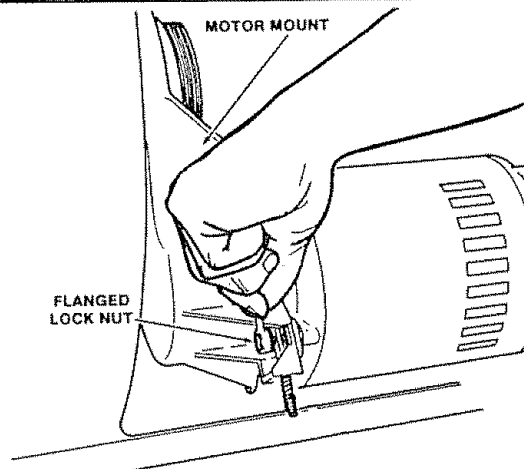

11. Install the wing nut on the threaded stud.
12. Check that the poly "V" belt is on both pulleys being sure that it is centered on each pulley.
13. Check that the pulleys are in line by sighting down the side of the large pulley to see if it lines up with the small pulley. If the pulleys are not in line, loosen the set screw holding the pulley on the motor shaft and position the pulley. A notch in the small end of the motor support is provided for access to the set screw and belt.

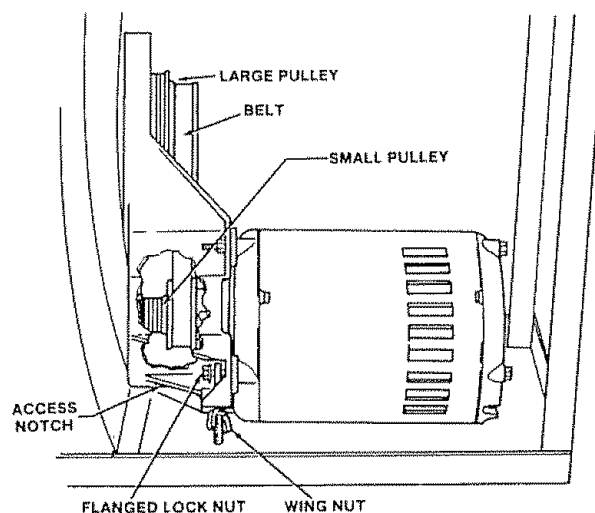

- 14 Belt tensioning is done by tightening the wing nut which pulls the motor down. The motor slides on the three (3) spacers and is locked in place by the flanged lock nut at the threaded stud.

Belt tension is important. Over tensioning may cause vibration while too little tension may allow the belt to slip under heavy loads

TIGHTEN FLANGE  
NUT AFTER TENSIONING  
BELT WITH WING NUT

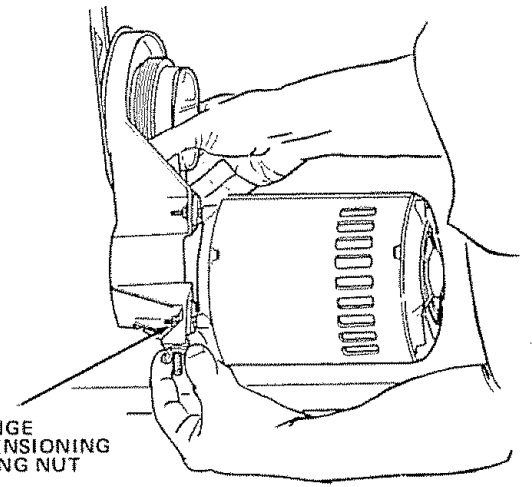

## CONNECTING THE MOTOR

1. Next, the motor cord needs to be wired into the motor. Coming from the underside of the table will be a cord with a black, white and green wire. This is the motor cord.

**WARNING: FOR YOUR OWN SAFETY, NEVER PLUG THE SAW IN UNTIL ALL ASSEMBLY STEPS ARE COMPLETED.**

2. Loosen the two screws holding the connector box cover on the back side of the motor. Swing the cover open.
3. Install the green ground wire by removing the green grounding screw and inserting it through the round metal terminal on the green ground wire of the motor cord. Reinstall the green screw into the hole from which it was removed and tighten securely.

**WARNING: TO AVOID ELECTROCUTION, NEVER CONNECT ANYTHING BUT THE GROUND WIRE (COLORED GREEN) TO THE GREEN SCREW.**

4. Insert terminal end of WHITE wire on spade terminal marked T4 on the motor. Push terminal firmly until seated.
5. Insert terminal end of BLACK wire on spade terminal marked T1 on the motor. Push terminal firmly until seated.
6. Close motor connector box being sure that power cord is seated in the largest strain relief groove and tighten box cover screws.
7. DO NOT plug in power cord.

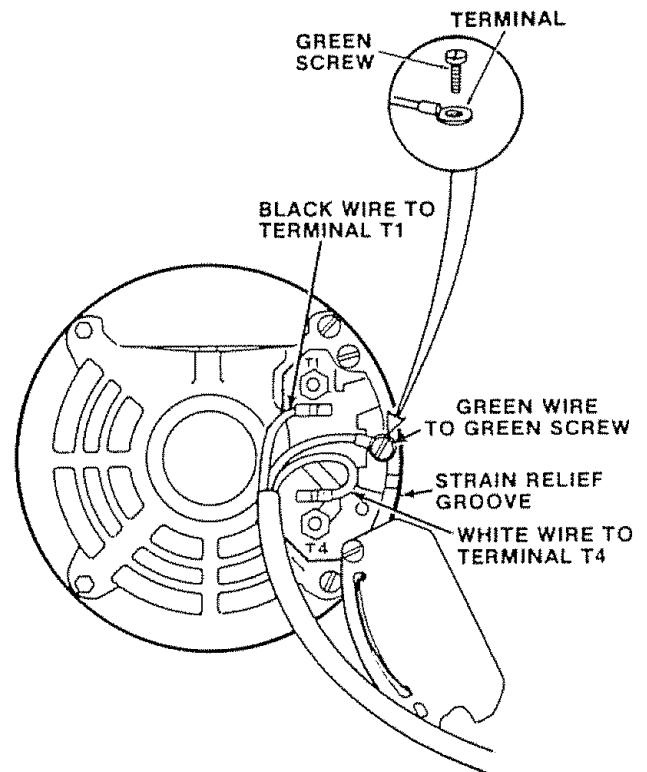

## SELECTING BLADE SPEED

The band saw has two speed settings: 3000 FPM for normal operation and 1500 FPM for operation requiring more control of the work piece.

When changing speeds from 1500 to 3000 FPM remove the belt from the band saw pulley first. When going from 3000 to 1500 FPM remove the belt from the motor pulley first

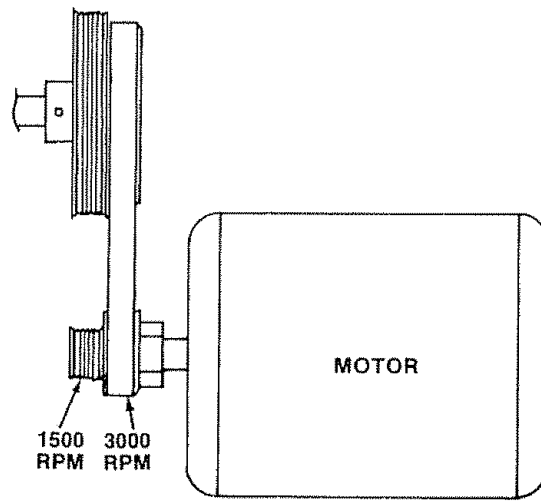

## RECOMMENDED SPEED SETTINGS

### 1. 3000 Feet per Minute

- a. Basic Wood Cutting.
- b. Resawing

Most effective with skip tooth, hook tooth, and regular tooth blades.

### 2. 1500 Feet per Minute

- a. Intricate Wood Cutting
- b. Veneers, Tile, Plastics
- c. Non-Ferrous Metals (Brass, Copper, Aluminum)\*

Most effective with blades that have 15 teeth per inch.

**CAUTION: This band saw will not cut steel. Steel cutting requires the blade speed to be 140 FPM.**

\*Must use recommended blade for non-ferrous metals.

## MOUNTING THE SAW TO THE LEG SET

### 1. From loose parts bag find the following hardware:

ITEM	DESCRIPTION	QTY.
A	Truss Head Bolts 1/4-20 x 1/2	4
B	Lockwashers External 1/4	4
C	Hex Nuts 1/4-20	4

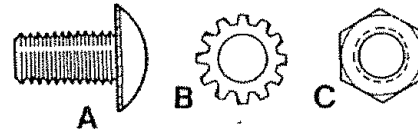

2. Place saw on leg set so that holes in bottom of saw line up with holes in top of leg set.
3. Install bolts, lockwashers, and nuts as shown. Tighten securely using a 7/16-inch wrench or socket. The front two bolts hold the saw, lower wheel cover and leg set together. Install these bolts from the bottom side.
4. After the band saw has been mounted to the leg set, go back and tighten all the nuts holding the leg set together.

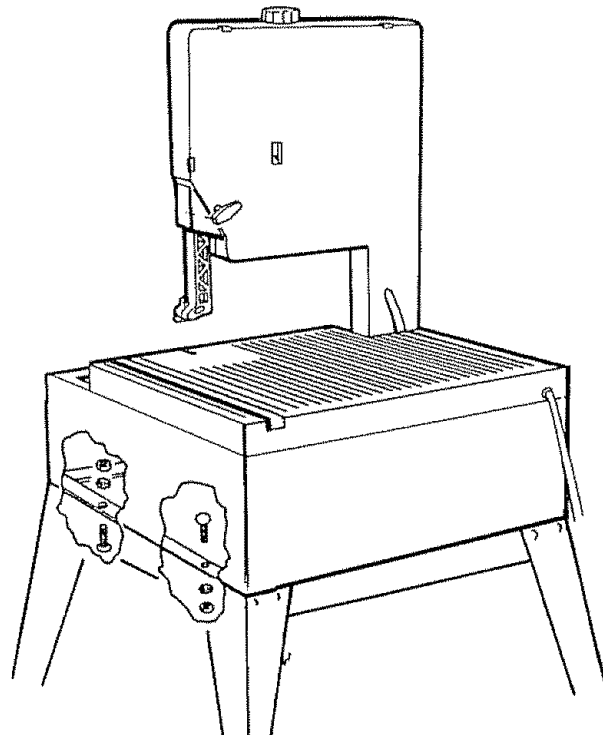
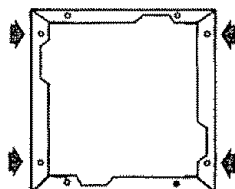

## ATTACHING TRIM CAPS & TRIM LEDGE

1. Locate the two (2) trim caps, the trim ledge, and from loose parts bag six (6) screws 1/4 x 1/2.
2. Place the trim ledge against the bottom of the base, then reach through the base and secure the trim ledge with the two screws using a phillips screwdriver.

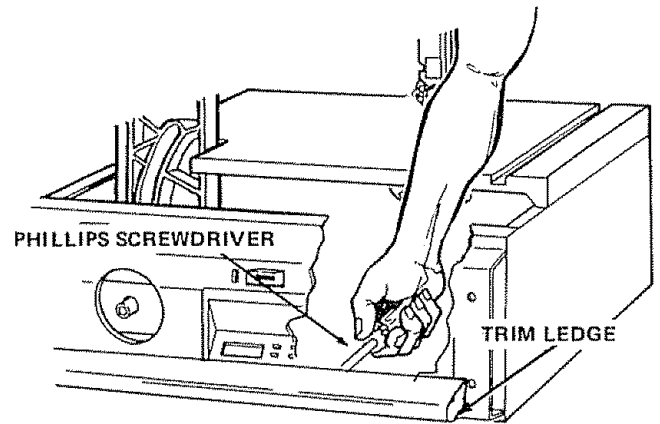

3. Position the trim caps in place and hold as illustrated.
4. Then reach through the base and secure the trim cap with the two (2) screws using a phillips screwdriver. Repeat procedure for other side.

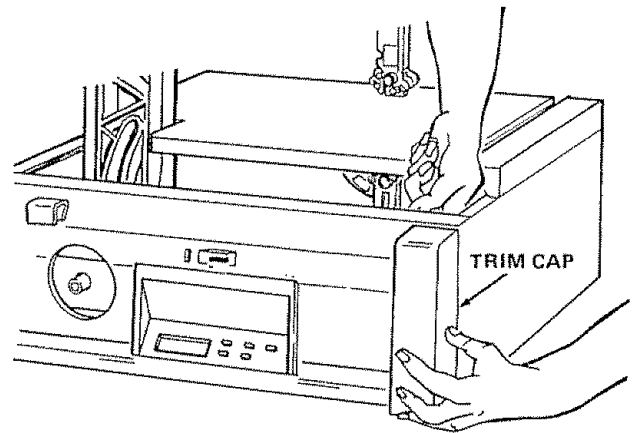

## ATTACHING THE HANDWHEEL

1. From loose parts bag find one (1) pan head screw 10-32 x 2 and one (1) hex nut. Install the handwheel. Reach inside the base to the back side of the bevel mechanism and put the nut in place. Hold the nut in place with a finger. Install the screw through the center of the handwheel and tighten with a phillips screwdriver.
2. Hold the handle and pull the red release button with your finger to close the handle.

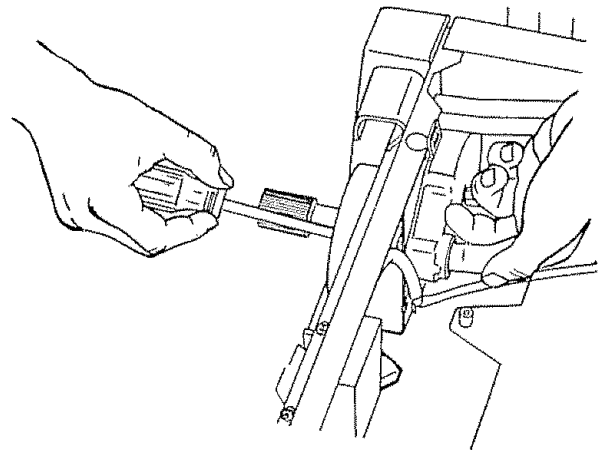

# getting to know your band saw

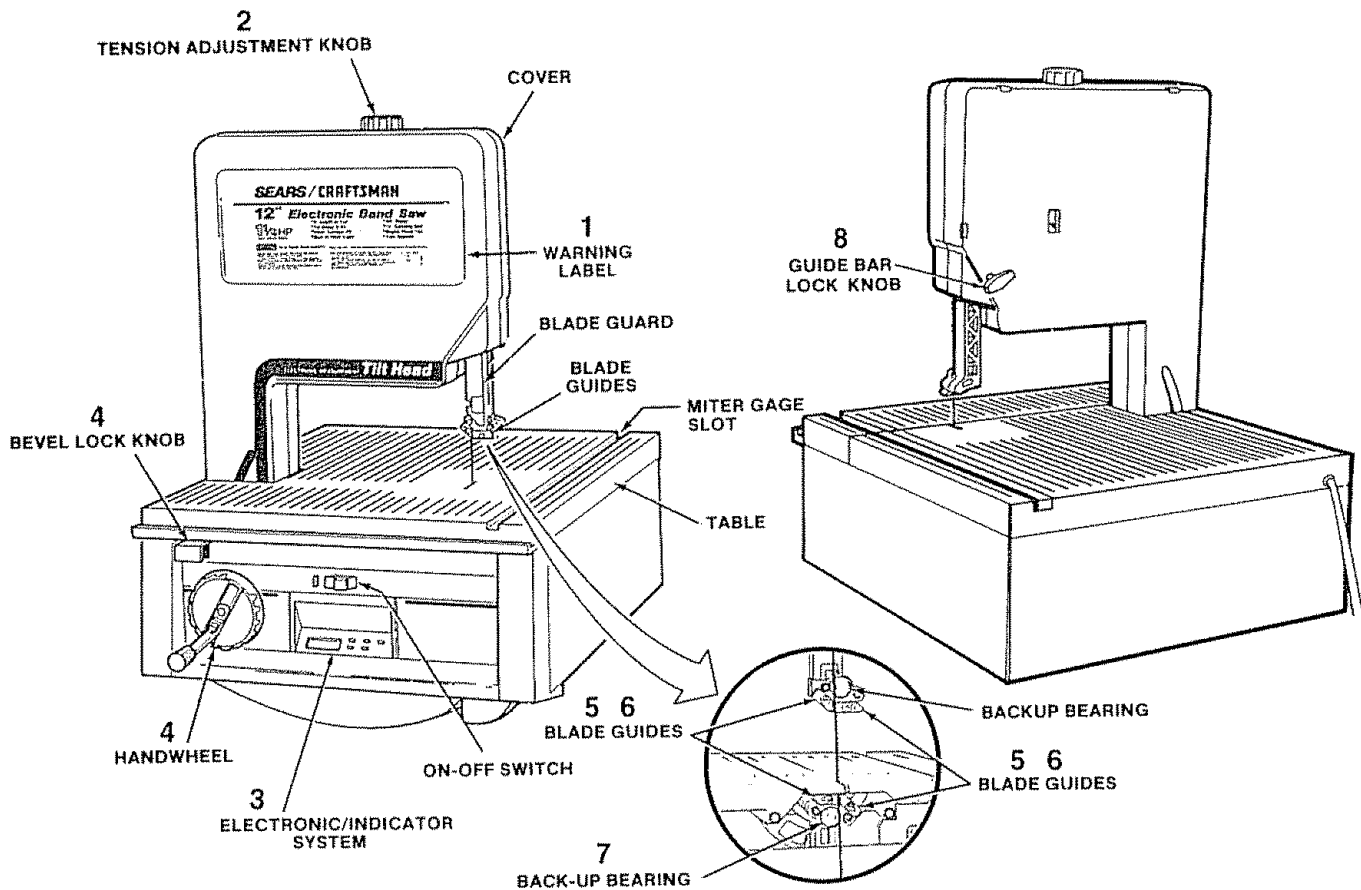

## GETTING TO KNOW YOUR BAND SAW

1. Warning Labels.
2. Tensions adjustment knob - Tightening the knob will increase the tension on the blade. Loosening it will decrease the tension. Clockwise to tension, counter clockwise to loosen.
3. Electronic Indicator System - Digital readout for blade tension, bevel angle and blade speed (FPM).
4. Setting Bevel Angle - Pull the bevel lock knob and adjust the band saw to the desired angle by turning the handwheel, then push in the bevel lock to secure.
5. Blade Guide Adjustment - The guides can be adjusted in or out for various widths of blades and locked in place by the set screws.
6. Lateral Blade Guide Adjustment - The guides can be adjusted sideways and locked in position by the capscrews to prevent the blade from twisting during operation.
7. Blade Backup Bearing Adjustment - The thrust bearings can be adjusted in or out for various widths of blades and locked in place by the setscrews.
8. Guide Bar Lock Knob - The upper blade guides should just clear the workpiece while cutting. Always adjust the guides before turning on the band saw and lock the guide bar by tightening the knob.

# location and function of the electronic indicator system

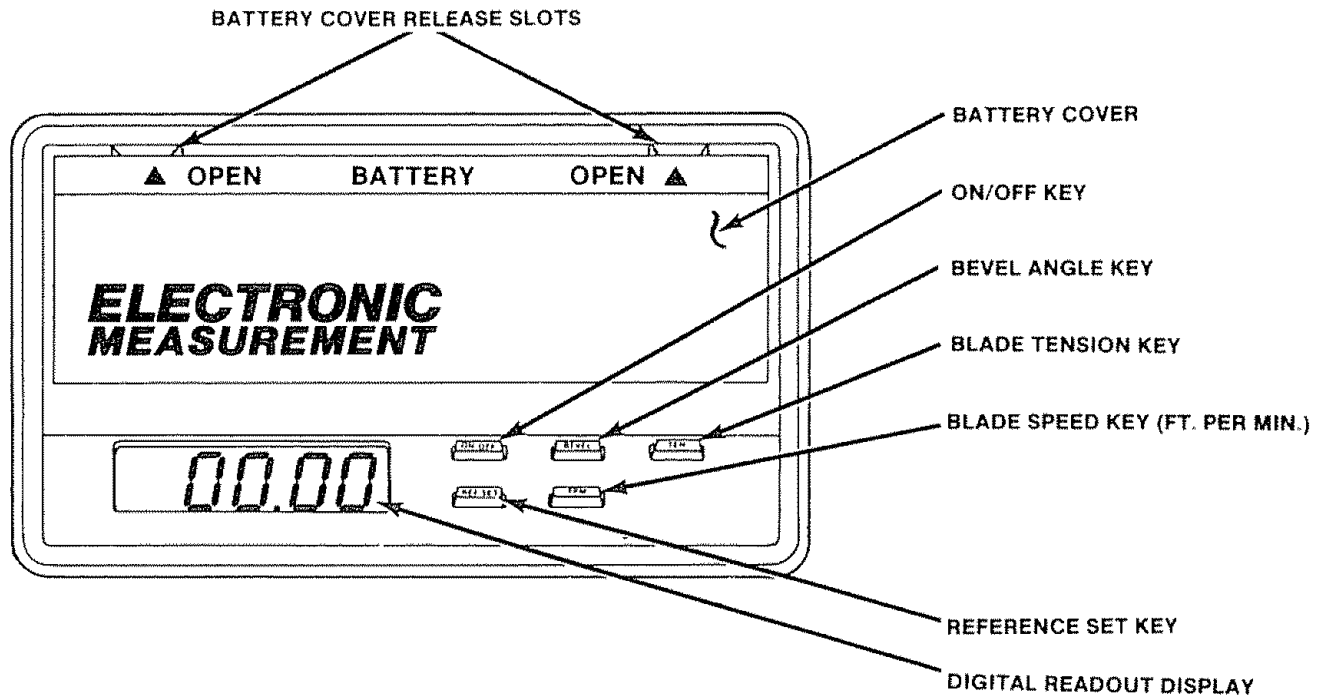

## DIGITAL READOUT DISPLAY

The Liquid Crystal Display, or LCD, on this saw gives the user the ability to accurately position the blade and monitor the set-up. The three functions displayed are:

**Bevel Angle** - Shows the present angle of the blade to the table. The  key is used to set the zero degree point

**Blade Tension** - Displays the blade size for which the tension has been adjusted.

**Blade Speed** - Displays the speed of the blade in surface feet per minute (FPM).

**NOTE:** The function being displayed is indicated by an abbreviated name of the function in the left hand area of the display; either BEV, TEN, or FPM.

## BATTERY COVER

The Battery Cover covers the battery compartment. To release the cover, insert a small coin into one of the release slots and twist. Remove the cover.





### 1. Installing the Battery

The battery is supplied with the loose parts. It is a 6-volt, type J alkaline battery. Install the battery with the contact end down and the "+" terminal towards the left. Push the battery down and back until the top edge of the battery is caught under the ribs in the compartment. Do not force the battery. If it doesn't push in easily, remove the battery and check that it is positioned correctly.

### 2. Reinstall battery cover by inserting the tabs on the lower edge of the cover into the mounting holes in the control and pushing the cover into position

## FUNCTION KEYS

The five keys located to the right of the display are the function keys. They are:

-  — Turns the display "On" or "Off"
-  — Selects the Bevel Angle display
-  — Selects the Blade Tension display
-  — Selects the Blade Speed display
-  — Sets the Bevel Angle to Zero

**NOTE:** In order to extend battery life the display will shut off approximately five (5) minutes after the last key was pressed.

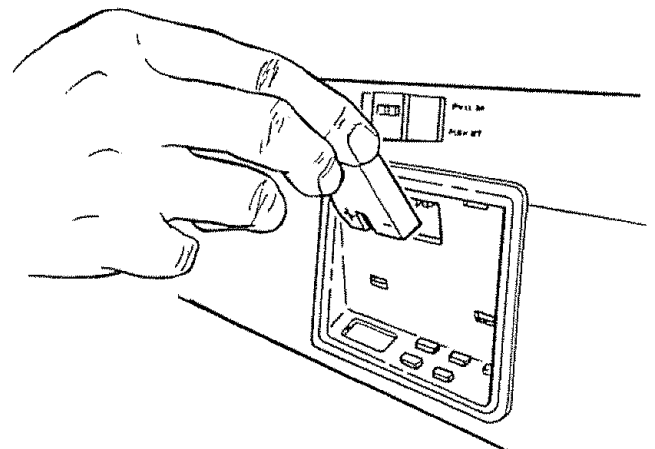

# USING THE ELECTRONIC INDICATOR SYSTEM

## 1. Setting the Bevel Angle Reference Point

Whenever the battery is installed or a new zero point is desired, it is necessary to set the zero reference. Normally the zero reference is set with the blade vertical to the table. When the blade is in the desired position for the zero point do the following.

- Press the **ON/OFF** key if display is off
- Press the **BEVEL** key, then the **REF SET** key.
- Display should read: 

## 2. Selecting Blade Tension

- Press the **ON/OFF** key if display is off.
- Press the **TEN** key.
- The digital display will show one of seven tension settings. Turn the tension knob until the correct read-out appears for the blade or sanding belt you have selected

Read-out	Indicates correct tension for:
L	Loose - no tension
S	Sanding Belt
.125	1/8" blade
.250	1/4" blade
.375	3/8" blade
.500	1/2" blade
E	Overtensioned

## 3. Blade Speed

The digital display will read out one of two starting speeds, depending on where the motor belt is positioned on the pulleys. The two starting speeds are 3000 FPM and 1500 FPM. The speed ranges for each starting point are:

<b>3000</b>	<b>1500</b>
2800	1400
*2600	*1300
2400	1200
2200	1100
2000	1000

The band saw motor will stall if the blade speed drops two steps\* below operating speed.

**NOTE:** It is important to maintain maximum cutting efficiency by keeping the blade speed as fast as possible. Do not feed the work piece too rapidly. It will overload the motor and stall the blade

## INSTALLING THE BLADE

1. Loosen the upper blade guide assembly and lower to approximately 3 inches above rear table and retighten lock knob. This is necessary to make adjustments to blade guide and back up roller bearing.

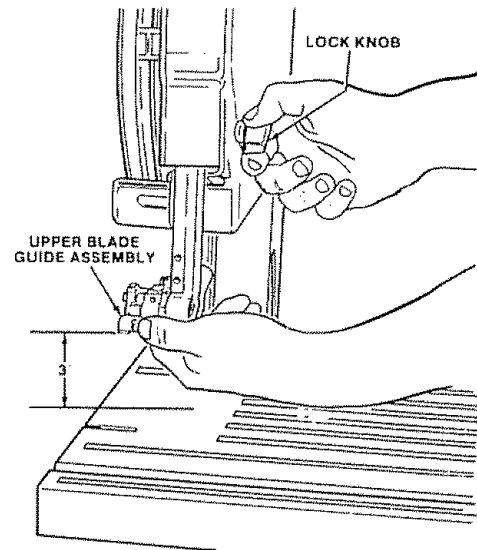

2. Remove the blade guard by loosening the two (2) mounting screws with a phillips screwdriver and lifting the blade guard upward.

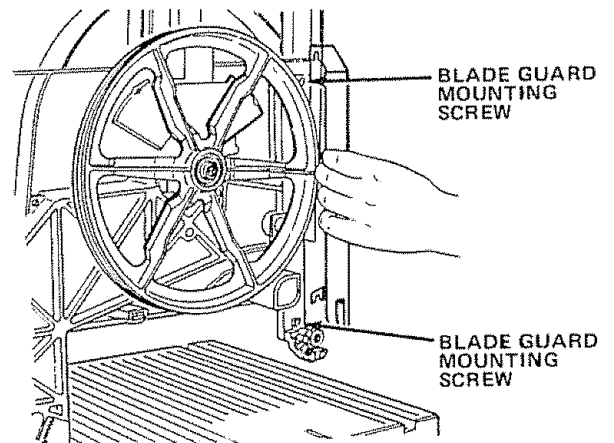

3. Loosen the two capscrews that lock the upper blade guides using a 1/8-inch hex "L" wrench and separate them about 1/8-inch. Repeat the same step for the lower blade guides.

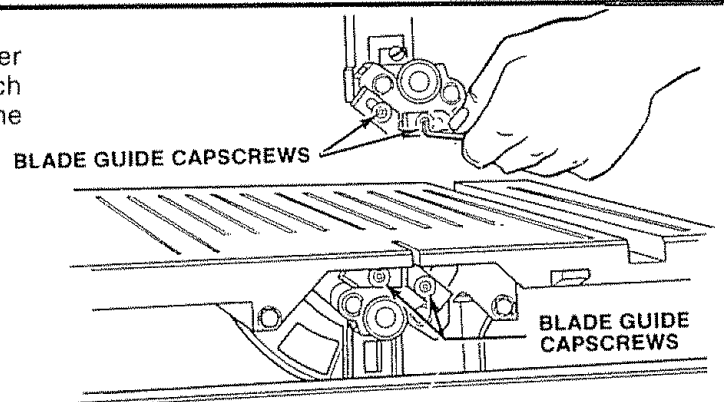

4. Loosen the setscrew which locks the blade guide support and push the support all the way back. Repeat for lower blade guide support.

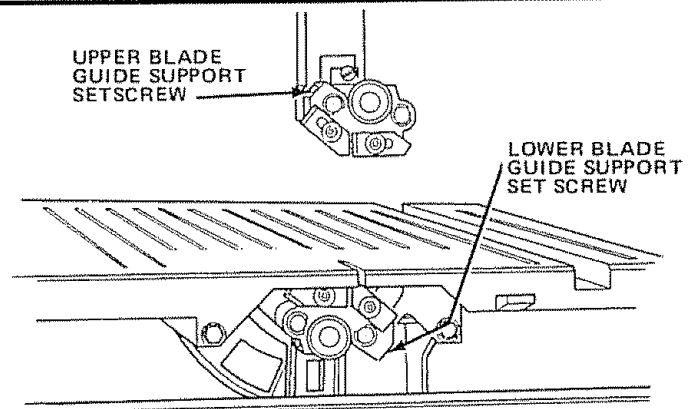

- Loosen the setscrew which locks the upper back up bearing and push the bearing all the way back. Repeat procedure for lower back up bearing.

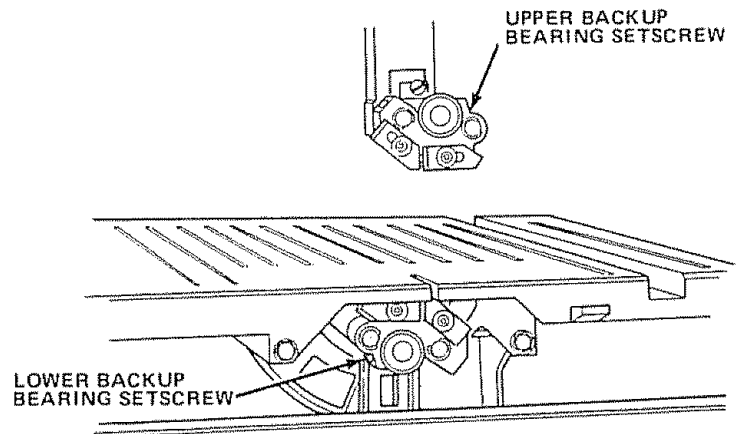

**CAUTION:** To avoid being scraped, if the blade should suddenly uncoil, wear safety goggles. Carefully uncoil the blade holding it at arms length.

- Uncoil the blade.
- Place the blade over the wheels with the teeth pointing downwards toward the table as shown. Make sure the blade is between the blade guides and is in the center of the rubber tires.

**NOTE:** If the blade will not reach around both wheels, lower the upper wheel by turning the tension knob counterclockwise.

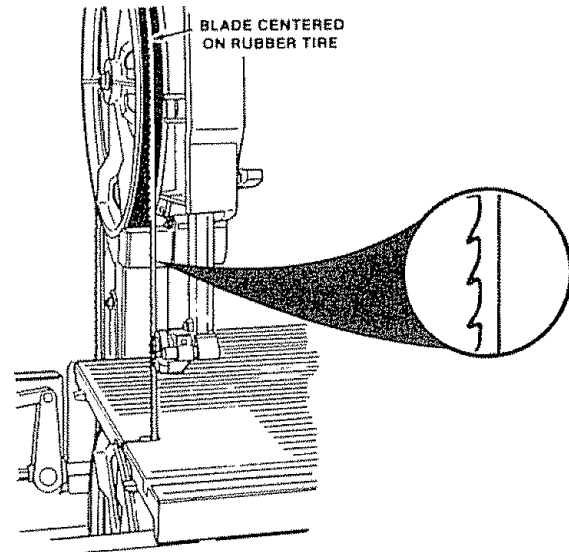

## ALIGNING THE BLADE AND BLADE GUIDE ASSEMBLIES

This band saw comes equipped with a 1/4-inch blade. This band saw can be used with blades of width from 1/8-inch to 1/2-inch. The alignment steps must be followed for proper tension, blade guide, and bearing adjustments for each different blade.

Refer to the blade usage section for the recommended blade size for best results during most band saw operations.

**NOTE:** It is critical to the life of the blade that the following steps are followed. Premature blade breakage will result if these steps are omitted.

- Turn on the digital display and push the **TEN** key. Turn the tension knob until the display reads .250. Turn the tension knob one additional turn. This will set the correct tension for 1/4-inch blade.

**WARNING: TO AVOID INJURY FROM UNEXPECTED STARTING OR ELECTRICAL SHOCK, DO NOT PLUG THE SAW IN. THE POWER CORD MUST REMAIN UNPLUGGED WHENEVER YOU ARE WORKING ON THE SAW.**

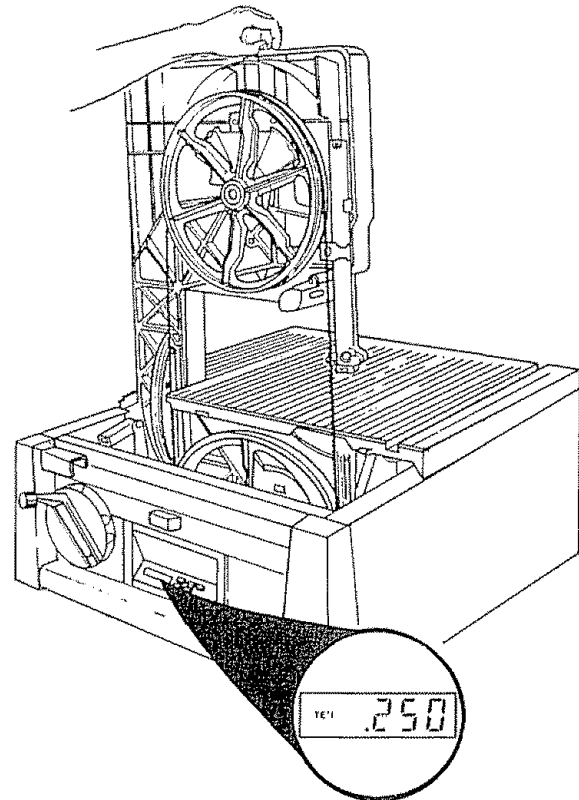

2. Turn the upper wheel by hand a few times and notice if the blade remains in the center of the tire on the top wheel.

If the blade moves away from the center of the tire while you are turning it, the blade is not tracking properly.

The top wheel shaft is hinged so the blade can be tracked. Tilt the wheel by turning the tracking adjustment screw using a medium screw driver. (See illustration.)

- a. If the blade moves toward the front of the band saw:

Turn the tracking adjustment screw clockwise about 1/4 of a turn, as though you were tightening it.

- b. If the blade moves toward the back of the band saw:

Turn the tracking adjustment screw counter-clockwise about 1/4 of a turn as though you were loosening it.

- c. Check adjustment by turning wheel by hand.

TRACKING ADJUSTMENT SCREW

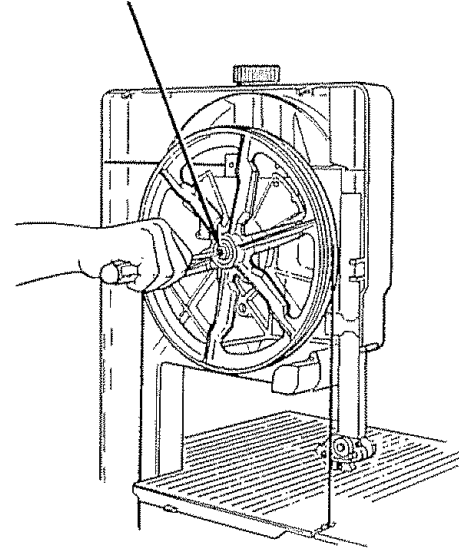

3. The upper and lower blade guides support the blade and keep it from twisting during operation. Adjust blade guide support whenever blades are changed or replaced with a different width.

4. Push the blade guide support toward the blade and adjust the blade guides so they are about 1/32-inch from the deepest part of the blade teeth. This deep part is called a gullet. Tighten the set screw locking the blade guide support. Turn the upper wheel, by hand, checking the position of the blade guide support.

**NOTE:** Letting the blade teeth hit the blade guides while using the band saw will ruin the blade. The set of the teeth and the sharpened edge of the teeth would be damaged. Proper adjustment of the upper and lower blade guide assemblies will prevent this from happening.

Repeat procedure for lower blade guide support.

5. Slide the two blade guides evenly against the sides of the blade. Do not push the blade guides or pinch the blade guides against the blade. Rotate the upper wheel by hand so the blade travels downward. This leaves proper space for blade. Make sure one guide is not further from the blade than the other. Tighten both setscrews with a 1/8-inch hex "L" wrench. Repeat procedure for lower blade guides.

**NOTE:** The backup bearings support the blade from the rear and will spin when the blade is pushed against them while you are cutting. As soon as you stop cutting, the bearings should stop spinning.

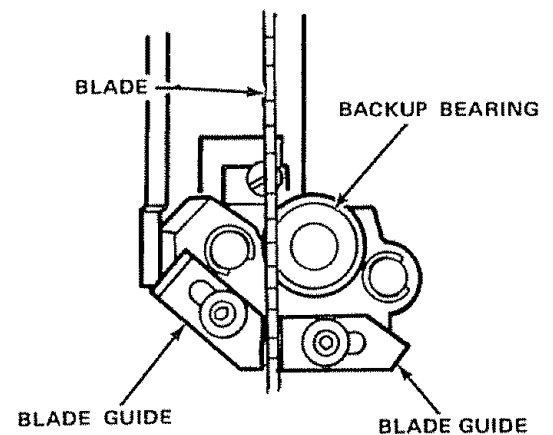
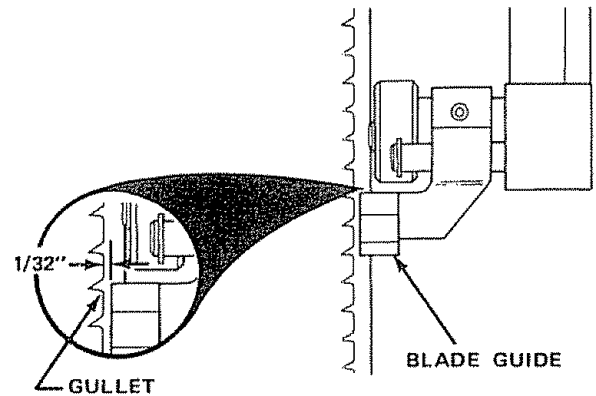

6. To insure the backup bearing is properly supporting the blade, push the bearing toward the blade until it almost touches it. Turn the upper wheel, by hand, checking the backup bearing to make sure it is not turning. If the bearing is turning the blade is too close. Move bearing slightly away from blade and tighten set screw with 1/8" hex "L" wrench. Turn upper wheel and recheck the bearing. Adjust again if necessary.
7. Repeat procedure for lower backup bearing.
8. Turn upper wheel by hand and check the blade guides and backup bearings to make sure they are adjusted correctly. Make any readjustments if necessary.
9. Install blade guard and tighten with phillips screwdriver (See illustration, page 19 )

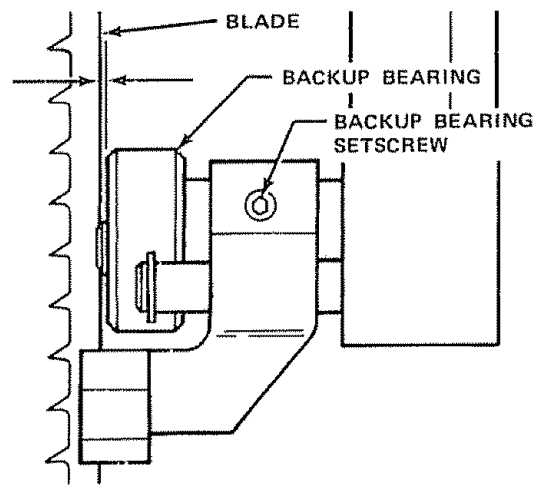

10. Install the front cover. Rest top edge of cover on two latch springs along the top edge of back cover. Swing cover down into position, engaging the three other latch springs. Push the front cover into position on the back cover. Check that the lip on the front cover completely overlaps the lip on the rear cover.

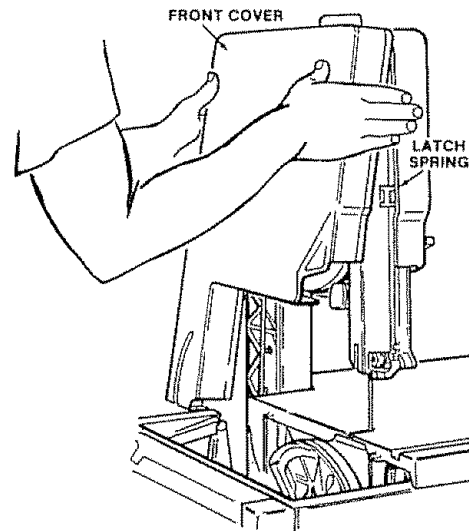

### MOUNTING THE FRONT TABLE

1. Turn front table over. Locate the two (2) latch springs, two (2) alignment springs, and the four (4) 1/4-20 x 5/8 hex washer head thread forming screws.
2. Install the two latch springs on the front table as illustrated using a 3/8-inch wrench or socket. Install the two alignment springs on the front table as illustrated using a 3/8-inch wrench or socket.

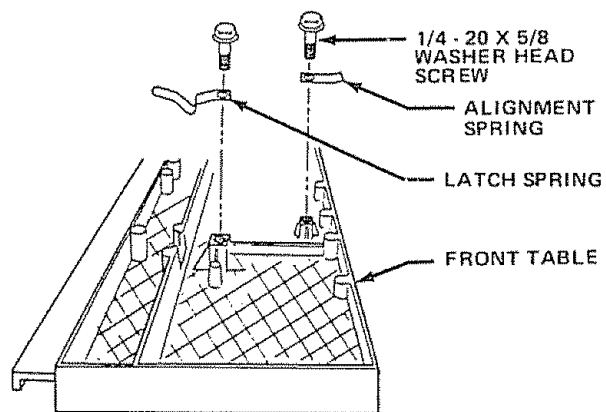

3. Locate the two (2) oval point setscrews 1/4-20 x 1/2 and use an 1/8-inch hex "L" wrench to install in the two holes, as illustrated, but do not allow the screws to extend beyond the underside of the table.

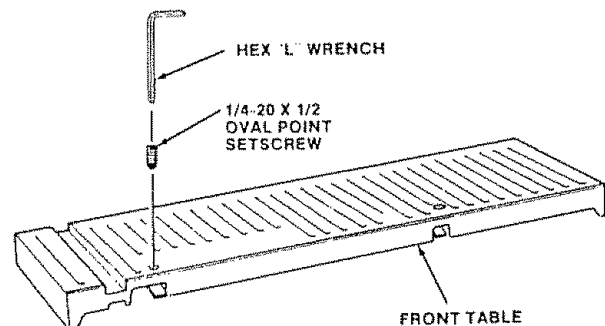

4. Locate the two (2) table latches, two (2) pan head screws, lockwashers, and hex nuts. Install the table latches to the underside of the front of the base in holes provided

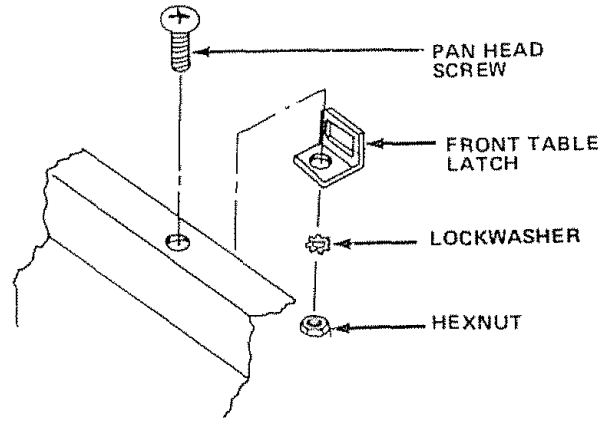
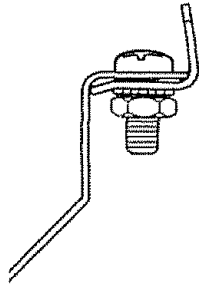

5. Locate the table alignment key and the two (2) 1/4-20 x 1 low head capscrews. Install the key under the rear table miter gage slot and install the two screws but do not tighten at this time

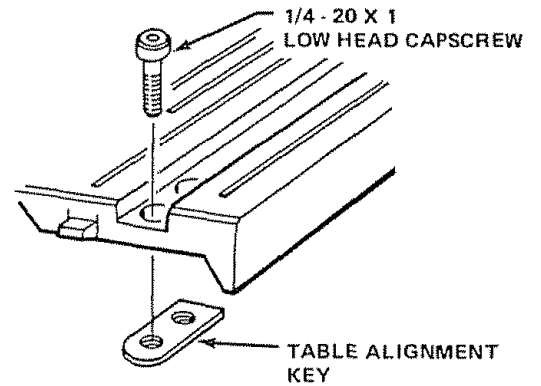

6. Mount the table to the base as follows:
- Hold the front edge of the table. Position the rear edge of the table so that the two flat springs slip under the two tabs on the rear table.
  - Line up the miter gage slots in the front and rear tables.
  - Push the front edge of the table backward and downward until the table snaps into position.

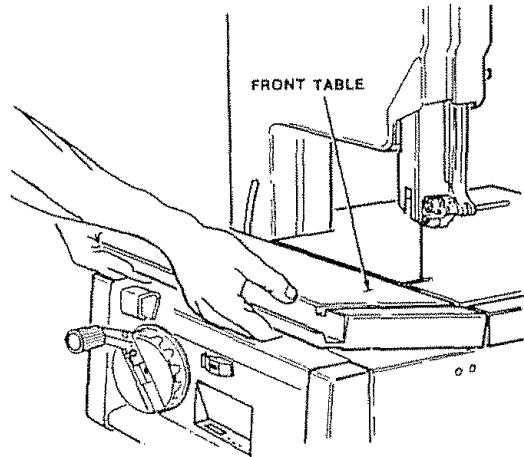

7. Use a 1/8-inch hex "L" wrench to adjust the two leveling setscrews to bring the rear edge of the front table up to the same height as the front edge of the rear table

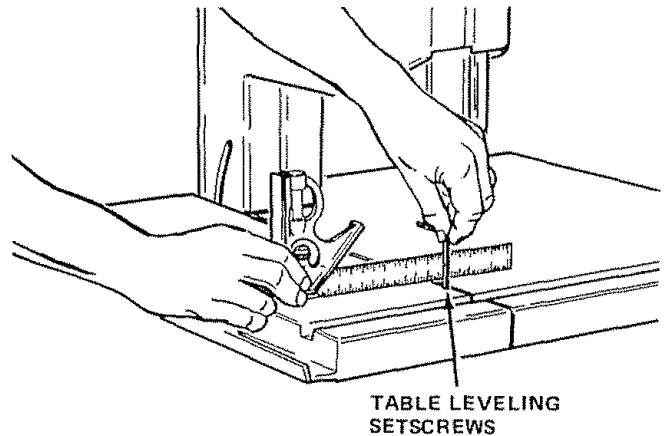

- 8 To keep the miter gage grooves in line, use a flat blade screwdriver against the head of one of the low head capscrews in the miter gage groove to force the table alignment key firmly forward into the notch in the front table
- 9 While holding the alignment key into the notch, tighten the other capscrew. Remove the screwdriver and tighten the remaining screw. Check that the miter gage grooves line up
- 10 Check the operation of springs and tabs by removing the front table and reinstalling. Remove the table by lifting up on two spring tabs under front edge of the table until springs are free, then pulling forward.

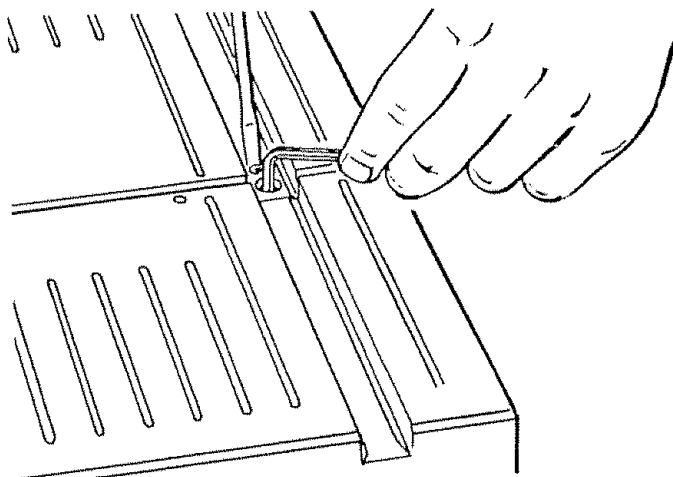

## SQUARING THE BLADE TO THE TABLE

To assure repeatability and accuracy, it is important to square the blade to the table and adjust the 0° position stop. This will guarantee that the blade will return to the square position after the head has been moved for a bevel cut.

1. Locate the 1/4-20 x 1/2 oval point setscrew and use an 1/8-inch hex "L" wrench to install it in the hole located at the left front of the rear table. The setscrew has a lock patch that will make it hard to turn.
2. Slide the upper blade guard to its top most position and tighten knob.
3. Release bevel lock by pulling out bevel lock knob under left front edge of table
4. Place a combination square on the table against the blade. Adjust the position of the blade to the table by turning the handwheel. When the blade is flush against the combination square lock the bevel lock knob. Use a 1/8-inch hex "L" wrench to set the 0° stop. Turn screw until it makes contact with the frame.
5. Unlock bevel lock, bevel the blade, then return to 0° position. Push in bevel lock knob and recheck blade to make sure it is square to the table.

**NOTE:** The combination square must be "true" — see the beginning of the unpacking and checking contents section for checking the combination square procedure.

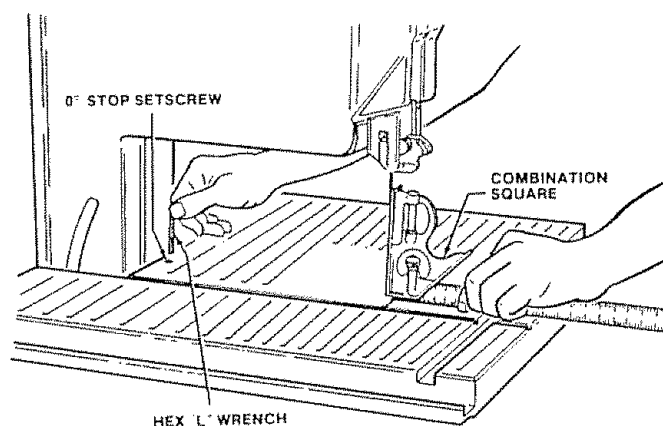

# location and function of controls

## ON-OFF SWITCH

**NOTE:** The On-Off switch has a locking feature. This feature is intended to help prevent unauthorized and possibly hazardous use by children and others.

- 1 Insert yellow key into switch.
- 2 To turn on, insert finger under end of red switch lever and pull end out.
- 3 To turn off switch, push red lever in towards the base.
- 4 **WARNING:** The locking feature provided is to help prevent unauthorized use of your saw. Always remove the yellow key and keep it in a safe place. To remove yellow key, hold thumb on the end of red lever to keep switch in "Off" position and pull yellow key straight out.

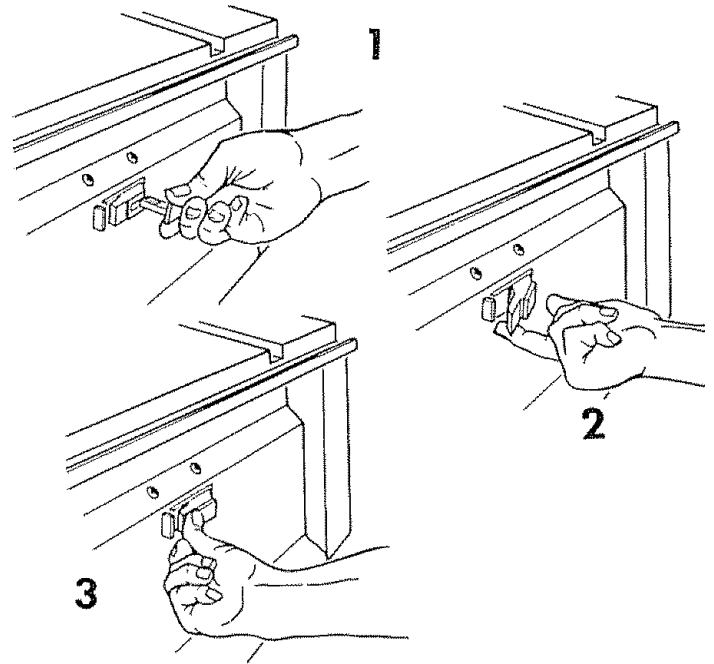

## TILTING HEAD FOR BEVEL CUT

1. Unlock bevel lock by pulling out on knob located under the left front edge of the table.
2. Turn handwheel counter-clockwise to increase the tilt angle of the blade. The digital display will read out the angle of the blade to the table.
3. Lock the bevel lock by pushing in on knob until it is fully seated when desired bevel angle is reached.

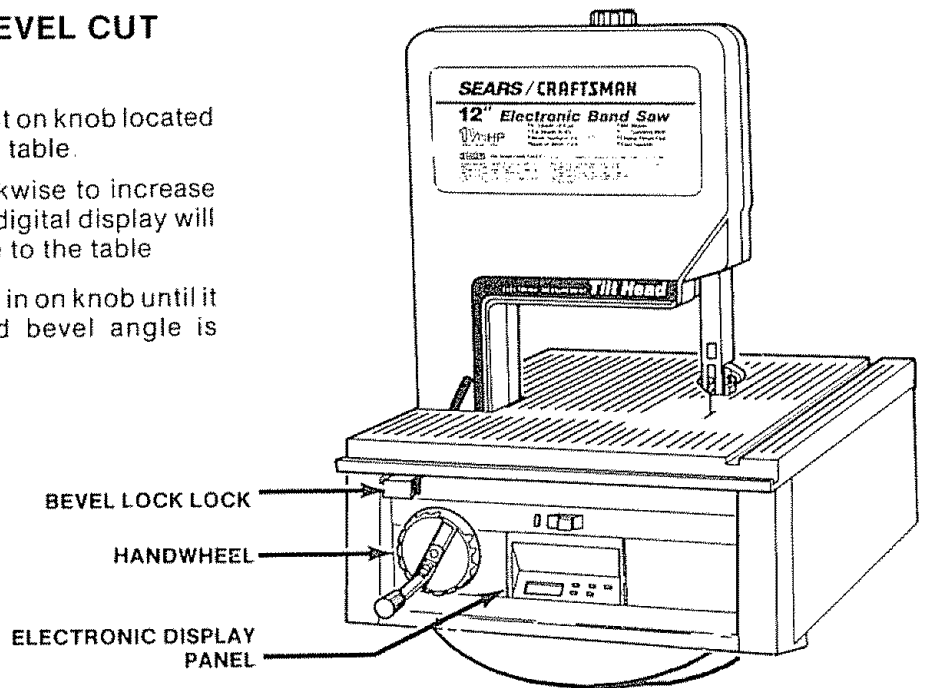

## ADJUSTING BEVEL LOCK KNOB

The bevel lock knob is factory adjusted and set. If after repeated use it becomes necessary to adjust:

1. Pull the bevel lock forward and bevel the band saw to 25 degrees.
2. Use a 9/16-inch wrench or socket to adjust the locking nut behind the band saw mounting frame. Turn nut clockwise to tighten.
3. Recheck bevel lock knob and readjust if necessary.

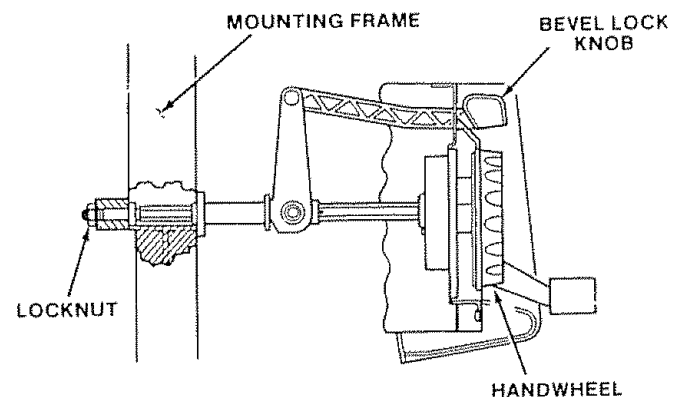

# basic band saw operation

**WARNING: FOR YOUR SAFETY, COMPLY WITH ALL THE SAFETY INSTRUCTIONS ON PAGES 2-4 BEFORE USING THE BAND SAW.**

A band saw is basically a "curve cutting" machine. It is not capable of doing inside cutting.

Your Craftsman Band Saw is not only capable of the usual band saw operations, but it can be converted into a sander as well. You can finish wood, certain compositions and plastics.

It is also used for straight-line cutting operations such as crosscutting, ripping, mitering, beveling, compound cutting, and resawing.

Operation	Recommended Blade Size (Inches)
Cross Cutting	1/4, 3/8, 1/2
Ripping	1/2
Mitering	1/4, 3/8, 1/2
Beveling	1/4, 3/8, 1/2
Compound Cutting	1/4, 3/8, 1/2
Circle Cutting	See Chart Below
Resawing	1/2
Curve Cutting	1/8, 1/4

## CIRCLE CUTTING

1. Adjust the upper guides to just clear the workpiece.
2. Use both hands while feeding the work into the blade. Hold the workpiece firmly against the table. Use gentle pressure, and do not force the work, but allow the blade to cut.
3. The smallest diameter that can be cut out is determined by the width of the blade. For example, a 1/4-inch wide blade will cut a minimum diameter of approximately 1-1/2-inch (see chart).

BLADE SELECTION GUIDE FOR MINIMUM CIRCLE CUTTING

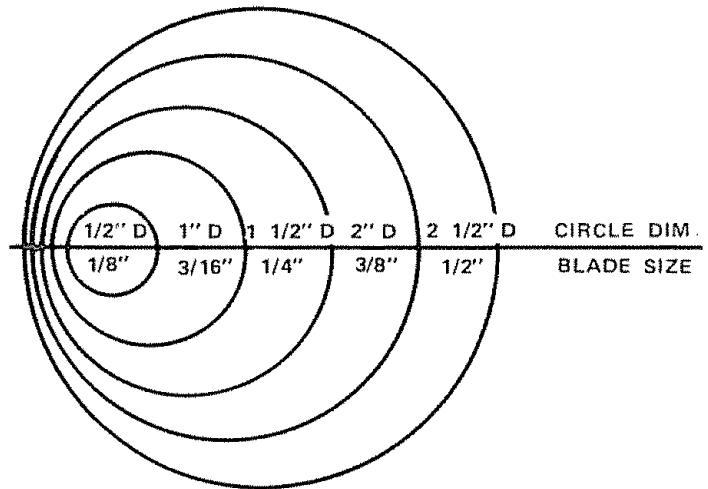

## SAWDUST COLLECTION

1. There is an opening provided in the rear of the bottom cover to attach a 2-1/2-inch hose from a wet/dry vac to control sawdust.

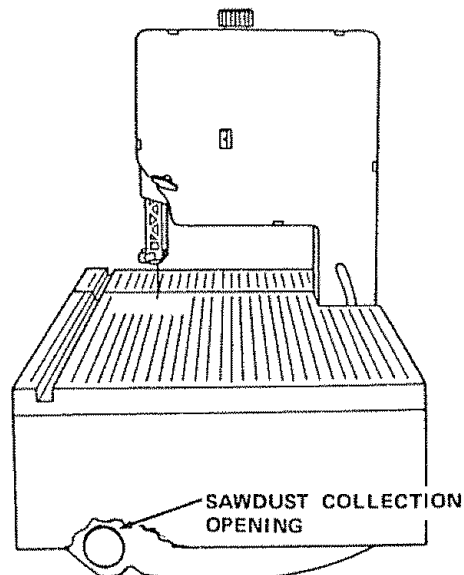

## INSTALLING SANDING ATTACHMENT

**NOTE:** The sanding belt cuts very rapidly. Practice with some scraps of wood first before you attempt to sand your actual workpiece

1. To install the sanding belt and sanding platen, remove the front table, front cover, blade guard, and the blade.
2. Use a 1/8-inch hex "L" wrench and remove the upper and lower right blade guides. The mounting screw used for the upper blade guide will be used to hold the sanding platen in place.
3. Loosen the setscrews that hold the upper and lower backup bearings in place and push the bearings all the way back. Tighten setscrews so bearings will remain.

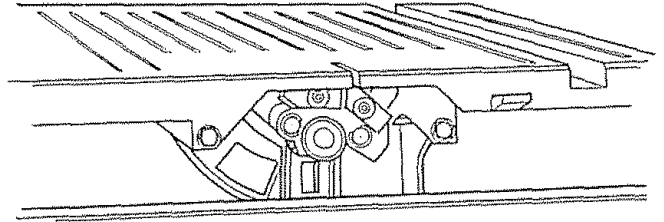
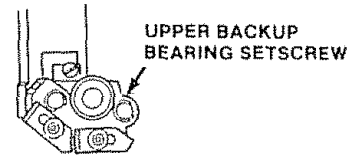

4. Slide the sanding platen into the blade slot in the table and fasten to the upper blade guide assembly where the right blade guide mounts. It may be necessary to loosen the left blade guide and slide it backwards until platen is in place.
5. Slide the upper left blade guide towards the sanding platen and tighten mounting screw securely.
6. Slide the lower left blade guide towards the sanding platen until the platen rests 1/8-inch away from the right edge of the slot in the work table.

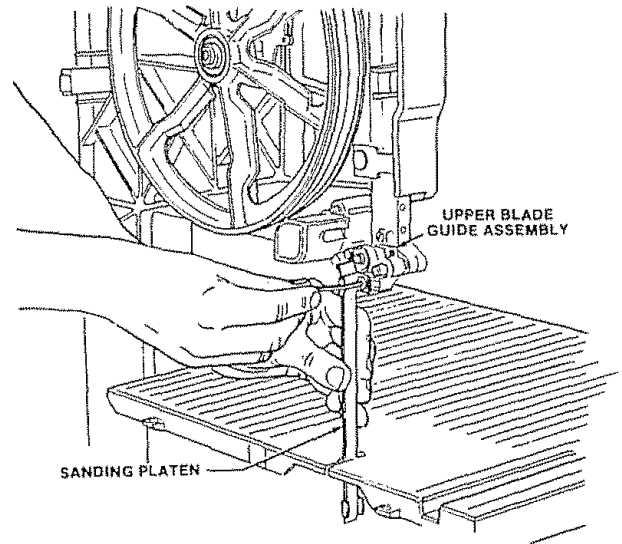

## INSTALLING THE SANDING BELT

1. Install the sanding belt and adjust tension to the sanding position. (The letter "S" on the scale.)  
**NOTE:** Check the tension often when a new belt is installed. A new belt will stretch during use.
2. Rotate the upper wheel by hand (clockwise) to check the sanding belt tracking. Adjust tracking if necessary. (Reference the blade tracking section for tracking procedure.)
3. After tracking the sanding belt if the belt and the platen do not align, loosen the upper blade guide support and slide the support in or out to align. Then tighten set screws to hold support and platen in place. It may also be necessary to adjust the lower blade guide support to align the blade guide with the sanding platen.

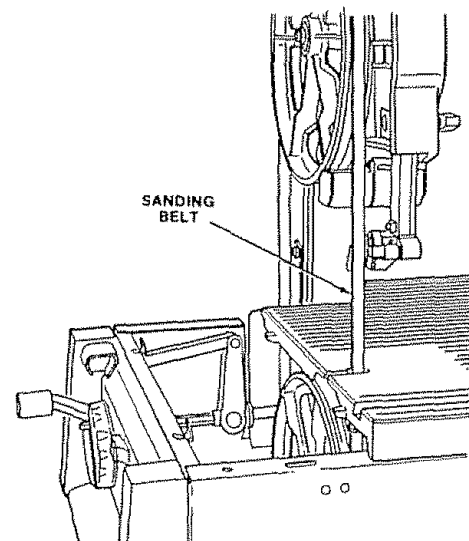

## recommended accessories

Miter Gauge .....	9-29929
Hold-Down Clamp for Miter Gauge .....	9-29928
Stop-Rods for Miter Gauge .....	9-29924
Rip Fence .....	9-23402
Blades and Sanding Belts .....	See Catalog
Circle Cutting Attachment .....	9-23411
Power Tool Know How Handbooks	
Radial Saw (includes band saw section) ..	9-2917
Table Saw (includes band saw section) ...	9-2918

The recommended accessories listed here are current and were available at the time this manual was printed.

# maintenance

**WARNING: FOR YOUR OWN SAFETY, TURN SWITCH "OFF" AND REMOVE PLUG FROM POWER SOURCE OUTLET BEFORE MAINTAINING OR LUBRICATING YOUR BAND SAW.**

## Tires

Pitch and sawdust that build up on the tires should be removed with a stiff brush or scraped off with a piece of wood.

**CAUTION: To avoid damaging the tires do not use a sharp knife or any kind of solvent.**

When the tires become worn they should be replaced. When replacing the tires, stretch them around the wheels but do not glue them on.

## ADJUSTING BAND SAW BEVEL TRAVEL

If the band saw will not hold its position when at a bevel angle, and before the bevel lock is locked, or if it is difficult to change the bevel angle, an adjustment is necessary to correct the force required to bevel the band saw.

To adjust the force required to bevel the band saw, locate the three (3) capscrews holding the frame to the motor mount. The capscrews are located in the recessed area behind the hub of the lower wheel at the 2 o'clock, 6 o'clock, and 10 o'clock positions. Use a 3/16-inch hexagonal "L" wrench that has a 4-inch leg, reach between the spokes of the lower wheel to the capscrews. Adjust the capscrews equally until the bevel action is smooth and the saw will hold its position before the bevel lock is locked.

## ADJUSTING THE UPPER BLADE GUIDE TRAVEL

If the upper guide bar will not move up and down easily or falls when the lock knob is loosened, the following adjustment should be performed.

1. Remove the Guide Bar Lock Knob and the washer which is under it.
2. Using a 7/16" socket or wrench, tighten the nut which is under the washer to just tight.

3. Then loosen the same nut 1 turn.
4. Move the guide bar up and down to check for smooth movement while still holding its position when released.
5. Make further adjustments to the nut as required to get the guide bar to move smoothly and hold its position when released.
6. Reinstall the washer and Guide Bar Lock Knob.

## General Maintenance

Keep your band saw clean. Remove the sawdust from the inside. Vacuum or blow out frequently.

Do not allow filth to build up on the table, the guides or the back-up bearings. Clean them with **Craftsman Gum and Pitch Remover**.

**CAUTION: Do not immerse the backup bearings in the gum and pitch remover.**

Put a thin coat of paste wax on the table so that the wood slides easily while cutting.

## Light Bulb

To replace the light bulb remove the front cover. Use a phillips screwdriver to remove the lens and replace the bulb. The light bulb is a 25 watt bayonet mount bulb.

## Motor

Frequently blow or vacuum out any sawdust from the motor. Follow lubrication instruction on the motor label.

**WARNING: TO AVOID EYE INJURY FROM BLOWING DEBRIS, WEAR SAFETY GOGGLES WHEN BLOWING OUT SAWDUST.**

**WARNING: TO AVOID ELECTROCUTION OR FIRE, IMMEDIATELY REPLACE A WORN, CUT, OR DAMAGED POWER CORD.**

## Lubrication

All of the ball bearings are packed with grease at the factory. They require no further lubrication.

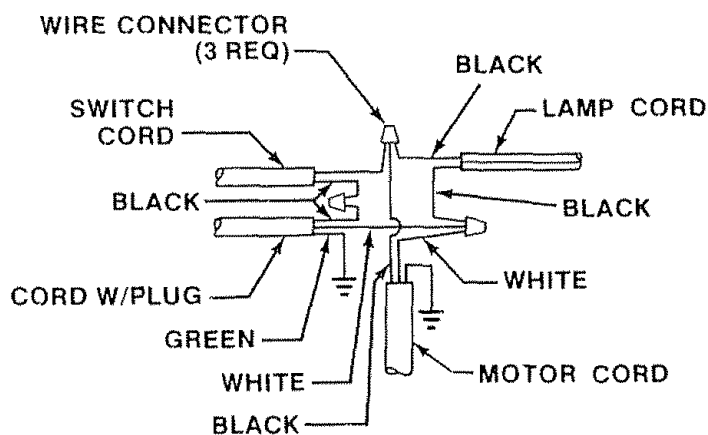

WIRING DIAGRAM

# trouble shooting

**WARNING: FOR YOUR OWN SAFETY, TURN SWITCH "OFF" AND REMOVE PLUG FROM POWER SOURCE OUTLET BEFORE TROUBLE SHOOTING YOUR BAND SAW/SANDER.**





TROUBLE	PROBABLE CAUSE	REMEDY
<b>Blade does not run in the approximate center of the upper wheel.</b>	1. Not tracking properly.	1. Adjust tracking, see Assembly Section, "Installing the Blade."
<b>Blade does not run in the approximate center of the lower wheel.</b>	1. Lower wheel not positioned correctly on shaft.	1. Reposition the wheel by loosening setscrew and slide wheel in or out to allow blade to run in center of wheel.
<b>Band Saw slows down when cutting.</b>	1. Belt too loose. 2. Cutting too small a radius. 3. Dull blade 4. Overloading motor.	1. Adjust belt tension, see Assembly Section "Installing and Aligning the Belt." 2. Stop feeding, and back up the material slightly, until the band saw speeds up. 3. Replace blade. 4. Slow down, trying to cut too fast.
<b>Blades breaking.</b>	1. Too much tension on blade 2. Kink in blade caused by cutting too small a radius or turning the material too fast when cutting.	1. Adjust tension. See Getting To Know Your Band Saw. 2. Use correct cutting technique. See Basic Band Saw Operation Section.
<b>Blade dulls too quickly.</b>	1. Blade guides set too close to teeth. 2. Cutting incorrect material.	1. Adjust upper and lower blade guides. See Assembly Section "Installing the Blade."
<b>Band saw vibrates.</b>	1. Too much tension on motor belt.	1. Adjust according to "Installing and Aligning Poly "V" Belt" section.

## trouble shooting — motor

**NOTE:** Motors used on wood-working tools are particularly susceptible to the accumulation of sawdust and wood chips and should be blown out or "vacuumed" frequently to prevent interference with normal motor ventilation and proper operation of the centrifugally-operated starting switch.

TROUBLE	PROBABLE CAUSE	REMEDY
<b>Excessive noise.</b>	1. Motor.	1. Have motor checked by qualified service technician. Repair service is available at your nearest Sears store.
<b>Motor fails to develop full power. NOTE: LOW VOLTAGE:</b> (Power output of motor decreases rapidly with decrease in voltage at motor terminals. For example, a reduction of 10% in voltage causes a reduction of 19% in maximum power output of which the motor is capable, and a reduction of 20% in voltage causes a reduction of 36% in maximum power output.)	1. Circuit overloaded with lights, appliances and other motors. 2. Undersize wires or circuit too long 3. General overloading of power company facilities	1. Do not use other appliances or motors on same circuit when using the saw. 2. Increase wire sizes, or reduce length of wiring. See "Motor Specifications and Electrical Requirements" section. 3. Request a voltage check from the power company
<b>Motor starts slowly or fails to come up to full speed.</b>	1. Low voltage 2. Windings burned out or open. 3. Starting switch not operating.	1. Request voltage check from the power company. Check size of circuit wiring. 2. Have motor repaired or replaced 3. Blow out sawdust from motor. Have motor repaired.
<b>Motor overheats.</b>	1. Motor overloaded. 2. Improper cooling (Air circulation restricted through motor due to sawdust accumulation.	1. Feed work slower into blade. 2. Clean out sawdust to provide normal air circulation through motor. See "Maintenance and Lubrication" section.
<b>Starting switch in motor will not operate.</b>	1. Burned switch contacts (due to extended hold-in periods caused by low line voltage, etc.) 2. Shorted capacitor. 3. Loose or broken connections.	1. Have switch replaced and request a voltage check from the power company. 2. Have capacitor tested and replace if defective. 3. Have wiring checked and repaired.
<b>Motor stalls</b> (resulting in blown fuses or tripped circuit breakers)	1. Starting switch not operating 2. Voltage too low to permit motor to reach operating speed. 3. Fuses or circuit breakers do not have sufficient capacity.	1. Have switch replaced. 2. Request voltage check from the power company. 3. Install proper size fuses or circuit breakers.
<b>Frequent opening of fuses or circuit breakers.</b>	1. Motor overloaded. 2. Fuses or circuit breakers do not have sufficient capacity 3. Starting switch not operating (motor does not reach speed)	1. Feed work slower into blade. 2. Install proper size fuses or circuit breakers. Check that wiring will handle load. 3. Have switch replaced. Blow out sawdust.

## trouble shooting — electronics

PROBLEM	PROBABLE CAUSE	SUGGESTED CORRECTIVE ACTION
<b>No display when  is pressed.</b>	<ol style="list-style-type: none"> <li>1. Battery incorrectly installed or missing</li> <li>2. Battery contacts dirty or corroded</li> <li>3. Battery dead.</li> <li>4. Digital display failure</li> </ol>	<ul style="list-style-type: none"> <li>- Adjust battery position in compartment.</li> <li>- Install battery</li> <li>- Clean battery contacts.</li> <li>- Replace battery. Battery is 6 volt, size J, alkaline type.</li> <li>- Have electronics checked <b>by qualified technician. Repair service available at nearest Sears Store.</b></li> </ul>
<b>Display shows </b>	<ol style="list-style-type: none"> <li>1. Normal display when battery is first installed in unit.</li> <li>2. Bevel display was not ref-set</li> <li>3. Poor battery contact to indicator display leads causing intermittent power to display.</li> <li>4. Digital display failure</li> </ol>	<ul style="list-style-type: none"> <li>- No action required.</li> <li>- Follow procedure for setting bevel reference point in this manual.</li> <li>- Clean battery contacts. Adjust battery position in compartment.</li> <li>- Have electronics checked <b>by qualified service technician. Repair service available at nearest Sears store.</b></li> </ul>
<b>Display dim.</b>	<ol style="list-style-type: none"> <li>1. Low battery voltage</li> <li>2. Temperature below 32° F.</li> </ol>	<ul style="list-style-type: none"> <li>- Replace battery. Battery is 6 volt, size J, alkaline type.</li> <li>- Allow saw to warm above 32° F.</li> </ul>
<b>Display dark.</b>	<ol style="list-style-type: none"> <li>1. Temperature above 120° F.</li> </ol>	<ul style="list-style-type: none"> <li>- Allow saw to cool below 120° F.</li> </ul>
<b>Display blanks after a few minutes.</b>	<ol style="list-style-type: none"> <li>1. Normal.</li> </ol>	<ul style="list-style-type: none"> <li>- Press  key. Display should return.</li> </ul>
<b>Display shows </b>	<ol style="list-style-type: none"> <li>1. Head tilted too rapidly for digital display to monitor.</li> </ol>	<ul style="list-style-type: none"> <li>- Reset bevel zero reference</li> </ul>
<b>Display will reset to zero but immediately shows when bevel is moved.</b> 	<ol style="list-style-type: none"> <li>1. Encoder or digital display defective.</li> </ol>	<ul style="list-style-type: none"> <li>- Have electronics checked <b>by qualified technician. Repair service available at nearest Sears store.</b></li> </ul>
<b>Display does not change when bevel is moved.</b>	<ol style="list-style-type: none"> <li>1. Wrong display function selected.</li> <li>2. Encoder or digital display defective.</li> <li>3. Rib on lower slide not engaging encoder.</li> </ol>	<ul style="list-style-type: none"> <li>- Select bevel function.</li> <li>- Have electronics checked <b>by qualified technician. Repair service available at nearest Sears store.</b></li> <li>- Have electronics checked by <b>qualified technician. Repair service available at nearest Sears store.</b></li> </ul>

## trouble shooting — electronics

PROBLEM	PROBABLE CAUSE	SUGGESTED CORRECTIVE ACTION
Display does not change when blade speed is changed.	<ol style="list-style-type: none"> <li>1. Wrong display function selected.</li> <li>2. Encoder or digital display defective.</li> </ol>	<ul style="list-style-type: none"> <li>- Select FPM function.</li> <li>- Have electronics checked <b>by qualified technician. Repair service available at nearest Sears store.</b></li> </ul>
Display changes back and forth between 3000 & 2800 in fpm function.	<ol style="list-style-type: none"> <li>1. Slight variations in in blade speed.</li> </ol>	<ul style="list-style-type: none"> <li>- Normal</li> </ul>
Display does not change when blade tension is changed.	<ol style="list-style-type: none"> <li>1. Wrong display function selected</li> <li>2. Encoder or digital display defective</li> <li>3. Encoder not engaged with tab on actuator.</li> </ol>	<ul style="list-style-type: none"> <li>- Select <span style="border: 1px solid black; padding: 2px;">TEN</span> function.</li> <li>- Have electronics checked <b>by qualified technician. Repair service available at nearest Sears store.</b></li> <li>- Engage tab of actuator with encoder.</li> </ul>
Display shows in tension function. <div style="border: 1px solid black; display: inline-block; padding: 2px; margin-top: 5px;">E</div>	<ol style="list-style-type: none"> <li>1. Blade too tight</li> </ol>	<ul style="list-style-type: none"> <li>- Normal. Reduce blade tension.</li> </ul>

# PARTS LIST FOR CRAFTSMAN 12-INCH ELECTRONIC BAND SAW MODEL 113.247440

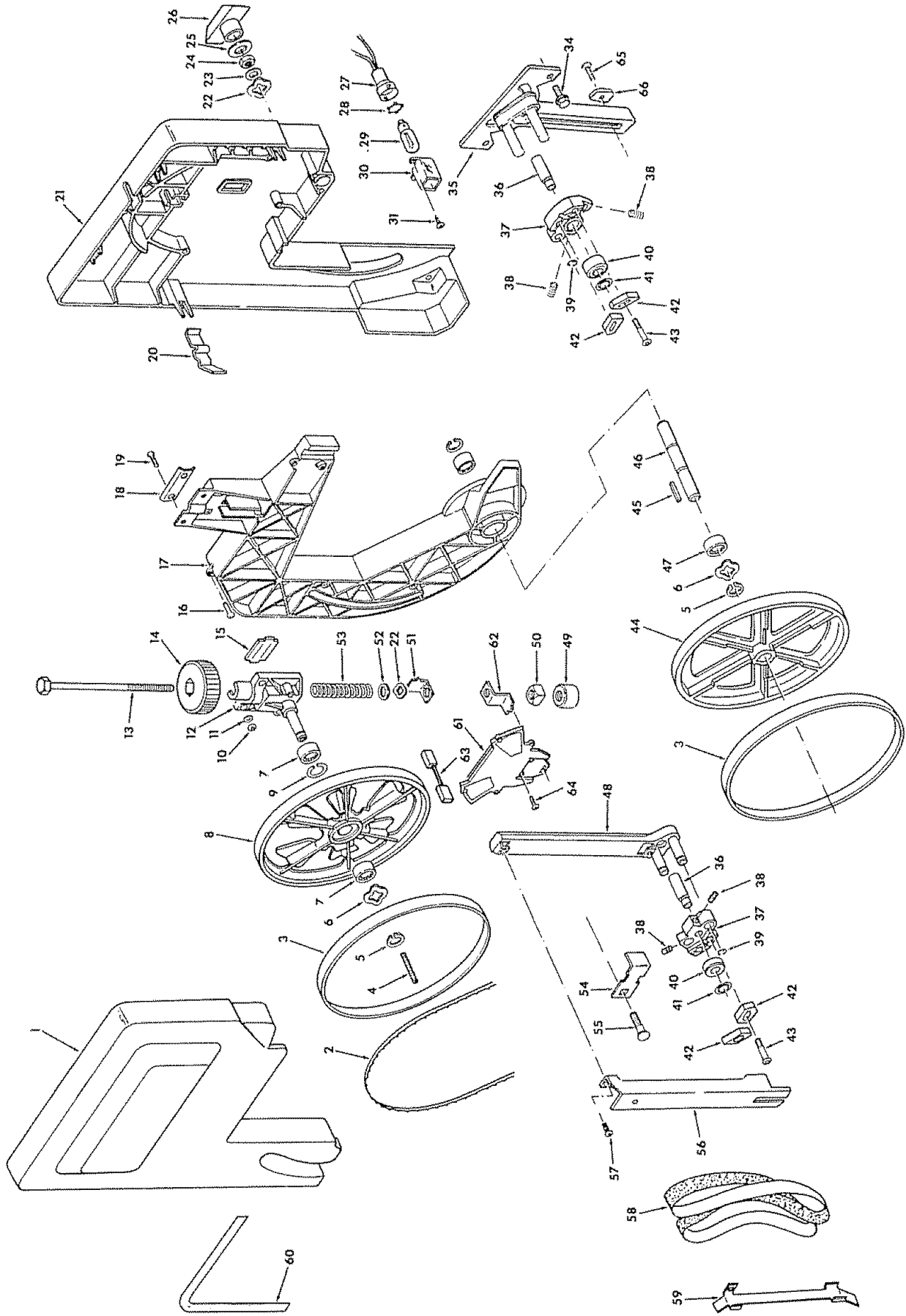

**PARTS LIST FOR CRAFTSMAN 12-INCH ELECTRONIC BAND SAW  
MODEL 113.247440**

Always order by Part Number - Not by Key Number

**FIGURE 1 - DRIVE ASSEMBLY PARTS**

Key No.	Part No.	Description
1	507830	Cover, Front w/Label
2	9-26595	†Blade, Band Saw
3	41815	Tire
4	816600	Screw, Sl. Hd Set 5/16-18 x 2-1/8
5	STD582062	*Ring, Retaining 5/8
6	41711	Washer, Spring
7	805034	Bearing, Ball
8	816419-2	Wheel, Upper
9	41812	Ring, Retaining 1-3/8
10	STD541431	*Nut, Lock 5/16-18
11	STD551031	*Washer, 21/64 x 5/8 x 1/32
12	816364	Support Assembly, Upper Wheel
13	816446	Screw, Blade Tension 3/8-16 x 10-1/4
14	816437	Knob, Blade Tension
15	816350	Plate, Support
16	808380-5	Screw, Pan Hd. Plastite #8 x 3/4
17	816433	Frame
18	816453	Plate, Pivot Support
19	STD533110	*Bolt, Carriage High Strength 5/16-18 x 1
20	816464	Latch, Cover
21	816429	Cover, Rear
22	808447-2	Washer, Wave 3/8 x 3/4 x .016
23	60128	Washer, 17/64 x 5/8 x 1/32
24	STD541425	*Nut, Lock 1/4
25	805552-20	Washer 17/64 x 1 x 1/16
26	816435	Knob, 1/4-20
27	816444	Socket, Light
28	808335-2	Retainer
29	STD372252	*Bulb, Light
30	816380	Lens
31	808380-1	Screw, Pan Hd. Plastite, No 6 x 3/8

Key No.	Part No.	Description
34	815865-2	Screw, Hex Wash Hd. 1/4-20 x 5/8
35	816362	Slide Assembly, Lower
36	816356	Shaft, Bearing Support
37	816365	Support, Guide
38	STD502502	*Screw Soc Set 1/4-20 x 1/4
39	808819-1	Ring, Retaining
40	STD315485	*Bearing Ball
41	60416	★Ring, Retaining 5/16
42	816379	Guide, Blade
43	60334	Screw, Socket Button Cap No 10-32 x 3/4
44	69059	Wheel, Drive
45	STD580103	*Key, 3/16 Sq. x 15/16
46	816387	Shaft, Lower Wheel
47	STD315238	*Bearing, Ball
48	816363	Slide Assembly, Upper
49	816349	Follower
50	816358	Nut, Heavy Square 3/8-16
51	816377	Indicator, Tension
52	STD551037	*Washer, .380 x .750 x .03
53	816353	Spring, Blade Tension
54	816361	Lock, Slide
55	109093	Bolt, Carriage 1/4-20 x 1-3/4
56	816388	Guard, Blade
57	813786-2	Screw, Pan Cross Hd. Type "TT" No 8-32 x 5/8
58	9-22361	†Belt, Sanding 1/2 x 80
59	816368	Platen, Sanding
60	816607	Label Trim
61	816406	Encoder Spd./Ten.
62	816599	Actuator Tension
63	816393	Cord Sensor
64	15545	Screw, Pan Hd Ty "T" 8-32 x 3/4
65	816273	Screw, Truss Hd. 1/4-20 x 1/2
66	818000	Guide, Lower slide
—	SP5225	Owners Manual (Not Ills )

\*Standard Hardware Item may be Purchased Locally.

†Stock Item - May be secured through the Hardware Department of most Sears Retail Stores or Catalog Order Houses

★If this part is removed, discard and replace with a new push nut.

# PARTS LIST FOR CRAFTSMAN 12-INCH ELECTRONIC BAND SAW MODEL 113.247440

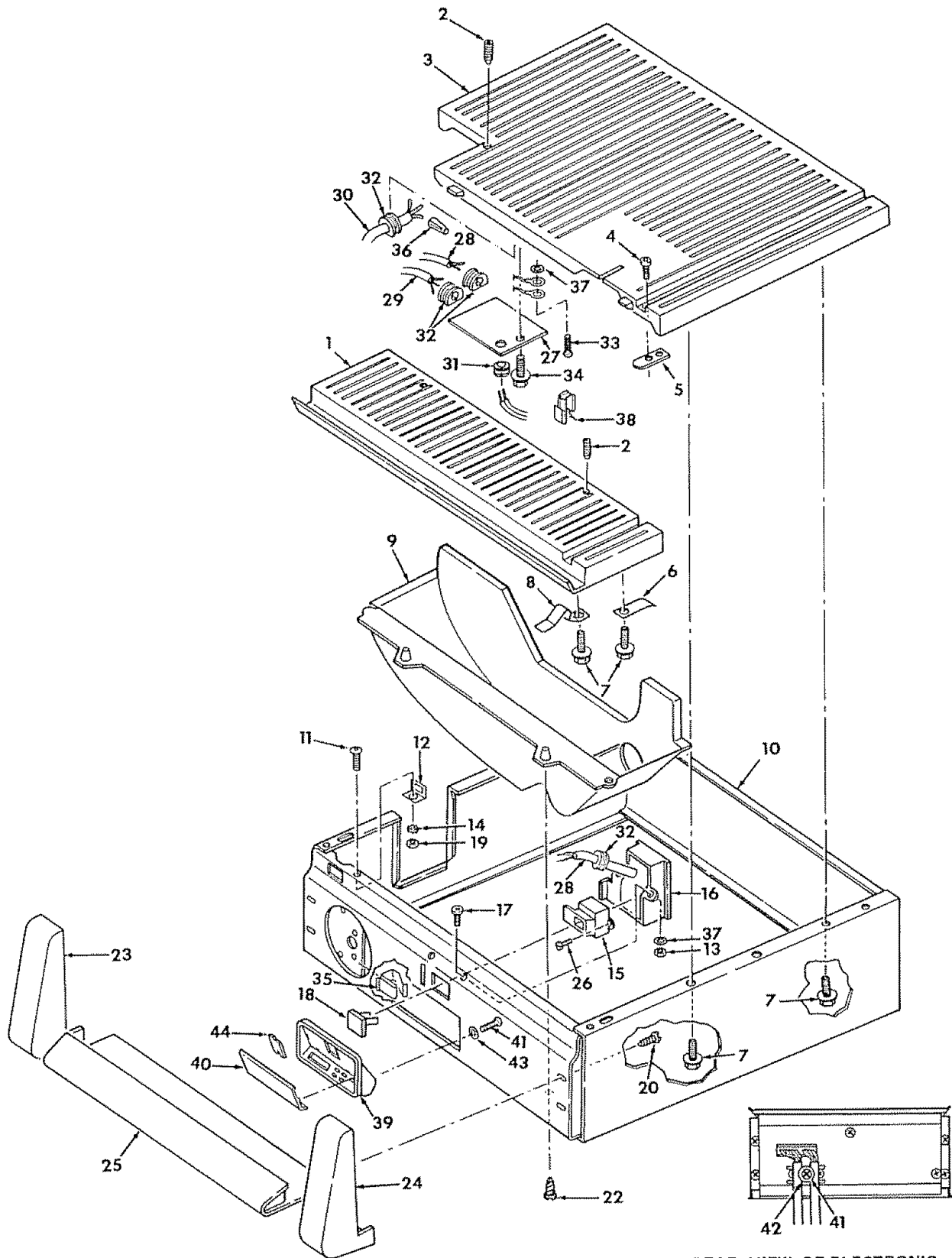

REAR VIEW OF ELECTRONIC CONTROL PANEL

**PARTS LIST FOR CRAFTSMAN 12-INCH ELECTRONIC BAND SAW  
MODEL 113.247440**

Always order by Part Number - Not by Key Number

**FIGURE 2 - BASE COMPONENTS**

Key No.	Part No.	Description
1	816434	Table, Front
2	806036-2	Screw, Locking Set 1/4-20 x 1/2
3	816420	Table, Rear
4	810214-2	Screw, Low Hd Cap 1/4-20 x 5/8
5	816371	Key, Table Alignment
6	816370	Spring, Table Alignment
7	815865-2	Screw, Hex Washer Hd Type "TT" 1/4-20 x 5/8
8	816442	Spring, Table Latch
9	816417	Cover, Bottom
10	816438	Base Assembly
11	STD512505	*Screw, Pan Hd 1/4-20 x 1/2
12	816441	Latch, Table
13	STD541110	*Nut, Hex 10-32
14	STD551225	*Lockwasher, Ext 1/4
15	816113	Switch, Locking
16	816403	Box, Switch
17	STD511105	*Screw, Pan Cross 10-32 x 1/2
18	815863	Key, Switch
19	STD541025	*Nut, Hex 1/4-20
20	815935	Screw, Pan Cross Type "BT" 1/4 x 1/2
22	60419	Screw, Pan Hd Plastite No 8 x 1/2

Key No.	Part No.	Description
23	815869	Cap, Trim L H.
24	815881	Cap, Trim R H.
25	815928	Trim, Ledge
26	808380-2	Screw, Pan Hd. Plastite No 8 x 3/8
27	816372	Plate, Cover
28	816436	Cord, Switch
29	816448	Cord, w/Plug
30	816888	Cord, Motor
31	169123-12	Relief, Strain
32	815868	Relief, Strain
33	816333-2	Screw, Pan Hd. Ty TT 10-32 x 3/8
34	STD522505	*Screw, Hex Wash Hd 1/4-20 x 1/2
35	62204	Clip, Cord
36	STD375006	*Connector, Wire
37	STD551210	*Lockwasher, Int #10
38	65093	Clip Wire
39	816404	Control, Band Saw
40	816376	Lid Battery
41	808380-1	Screw, Pan Hd. Plastite #6 x 3/8
42	STD551008	*Washer 3/16 x 1/2 x 1/32
43	STD551206	*Lockwasher Int. #6
44	STD363539	•Battery
—	507655	Bag of Loose Parts (Not Ills )
—	507741	Bag of Loose Parts (Not Ills )

\*Standard Hardware Item may be Purchased Locally

- Can also use these battery numbers:  
Eveready #539  
Rayovac #867  
Duracel #7K67

**PARTS LIST FOR CRAFTSMAN 12-INCH ELECTRONIC BAND SAW  
MODEL 113.247440**

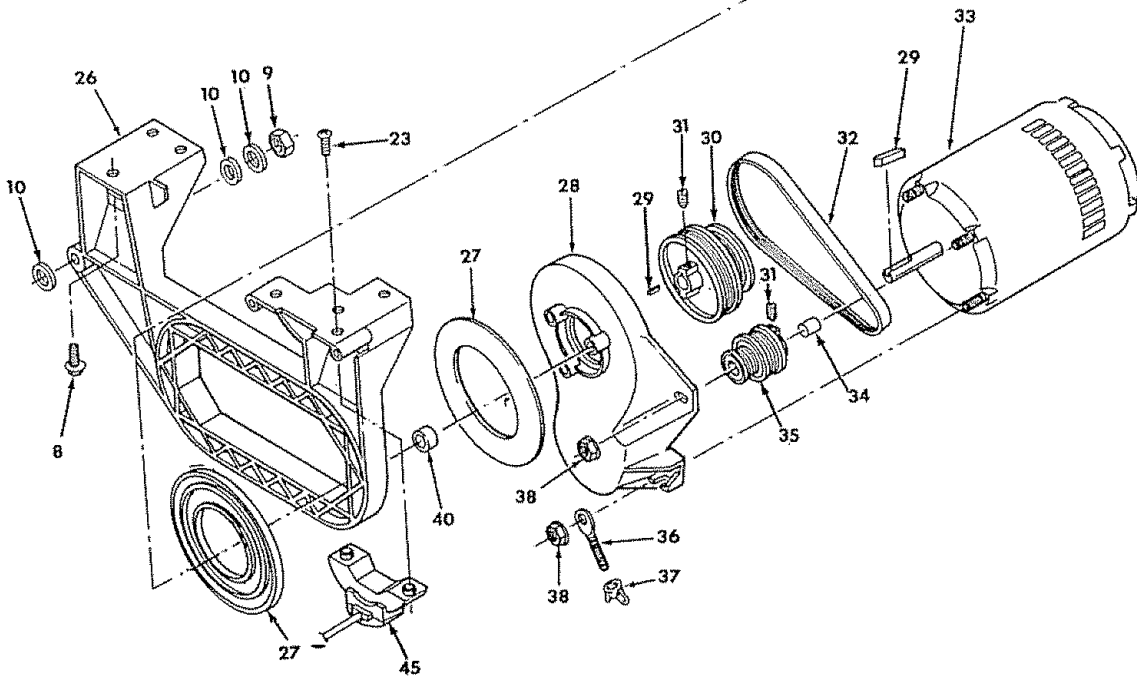
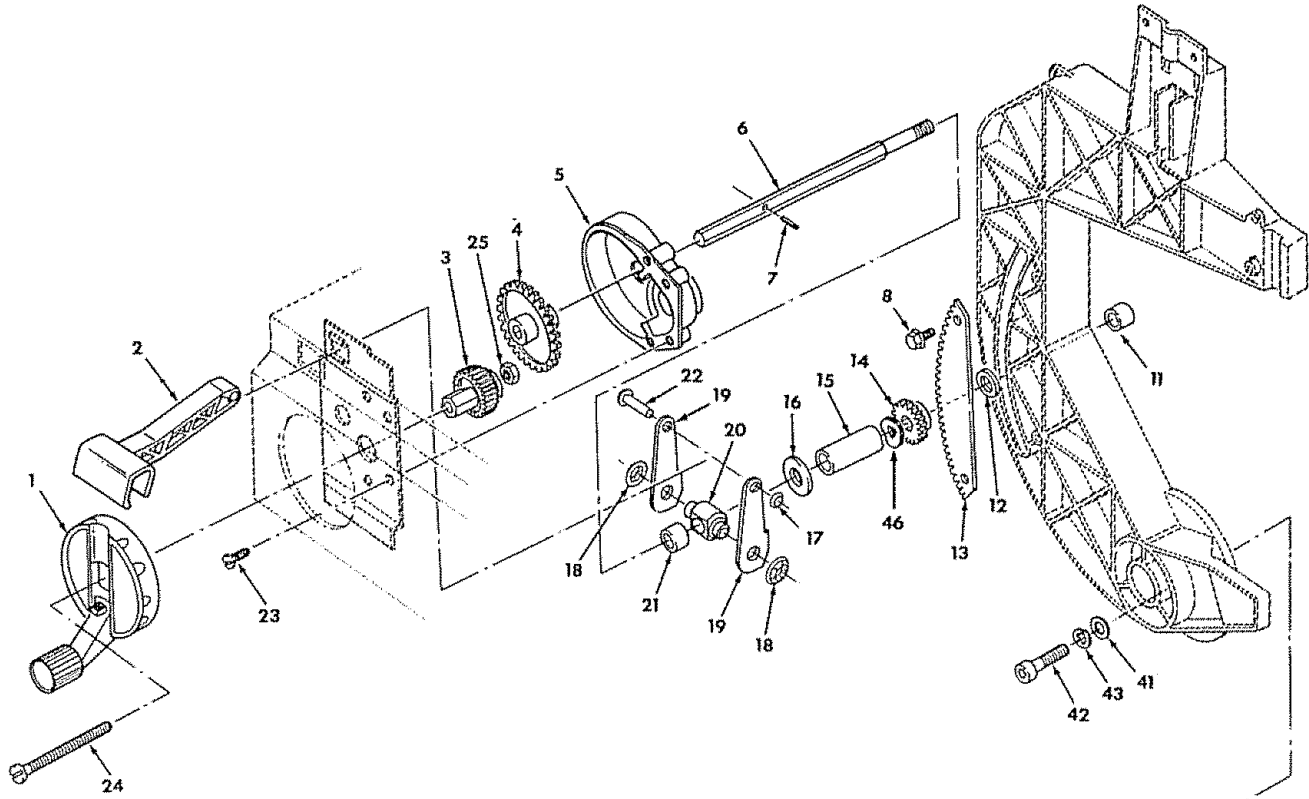

**PARTS LIST FOR CRAFTSMAN 12-INCH ELECTRONIC BAND SAW  
MODEL 113.247440**

Always order by Part Number - Not by Key Number

**FIGURE 3 - BEVEL DRIVE AND MOTOR MOUNT ASSEMBLY PARTS**

Key No.	Part No.	Description
1	816499	Handwheel Assembly
2	816386	Knob, Bevel Lock
3	816381	Pinion, Handwheel
4	816384	Gear, Handwheel
5	816543	Cover, Bevel Gear
6	816382	Shaft, Bevel
7	STD571207	*Pin, Roll 1/8 x 3/4
8	815865-2	Screw, Hex Washer Hd Ty TT 1/4-20 x 5/8
9	9414202	Nut, Lock 3/8-16
10	805556-23	Washer, .380 x .750 x .03
11	816452	Spacer 9/16 x 1/4
12	60317	Washer, 21/32 x 1 x 1/64
13	816443	Gear, Segment
14	816348	Pinion, Bevel Drive
15	802392-38	Spacer 1/2 x 2
16	805562-1	Washer, .507 x 1.25 x .125
17	60208	★Nut, Push 1/4
18	60240	★Nut, Push 3/8
19	816360	Cam, Bevel Lock
20	816359	Mount, Bevel Lock
21	816465	Spacer 1/2 x .59
22	815774-3	Rivet 1/4 x 1-1/8
23	60419	Screw, Pan Hd Plastite No 8 x 1/2
24	809372-18	Screw, Pan Hd 10-32 x 2

Key No.	Part No.	Description
25	STD541110	*Nut, Hex 10-32
26	816504	Support Frame
27	817165	Washer, Plastic
28	816422	Mount, Motor
29	STD580103	*Key 3/16 Sq x 15/16
30	816407	Pulley, Polyrib 2 Step
31	STD503105	*Screw, Set 5/16-18 x 1/2
32	816439-2	Belt, Poly V
33	816612	▲Motor 1725 R P M.
34	60453	Spacer, Motor Mount #10 x 5/16
35	816390	Pulley, Polyrib 2 Step
36	816815	Stud, Belt Tension
37	STD541631	*Nut, Die Cast Wing 5/16 x 18
38	816817	Nut, Hex Flange Lock 10-32
40	816445	Bushing, Rubber
41	STD551012	*Washer 17/64 x 1/2 x 1/32
42	815992-1	Screw, Hex Socket Head Ty "TT" 1/4-20 x 3/4
43	STD551125	*Lockwasher 1/4
44	STD502505	*Screw, Soc. Set 1/4-20 x 1/2
45	816405	Encoder Bevel
46	813024-4	Washer, Spring

\*Standard Hardware Item may be Purchased Locally

★If this part is removed, discard and replace with new push nut.

▲Any attempt to repair this motor may create a hazard unless repair is done by a Qualified Service Technician  
Repair Service is available at your nearest Sears Store.

**PARTS LIST FOR CRAFTSMAN 12-INCH ELECTRONIC BAND SAW  
MODEL 113.247440**

**FIGURE 4 - PARTS LIST LEG SET**

Always order by Part Number - Not by Key Number

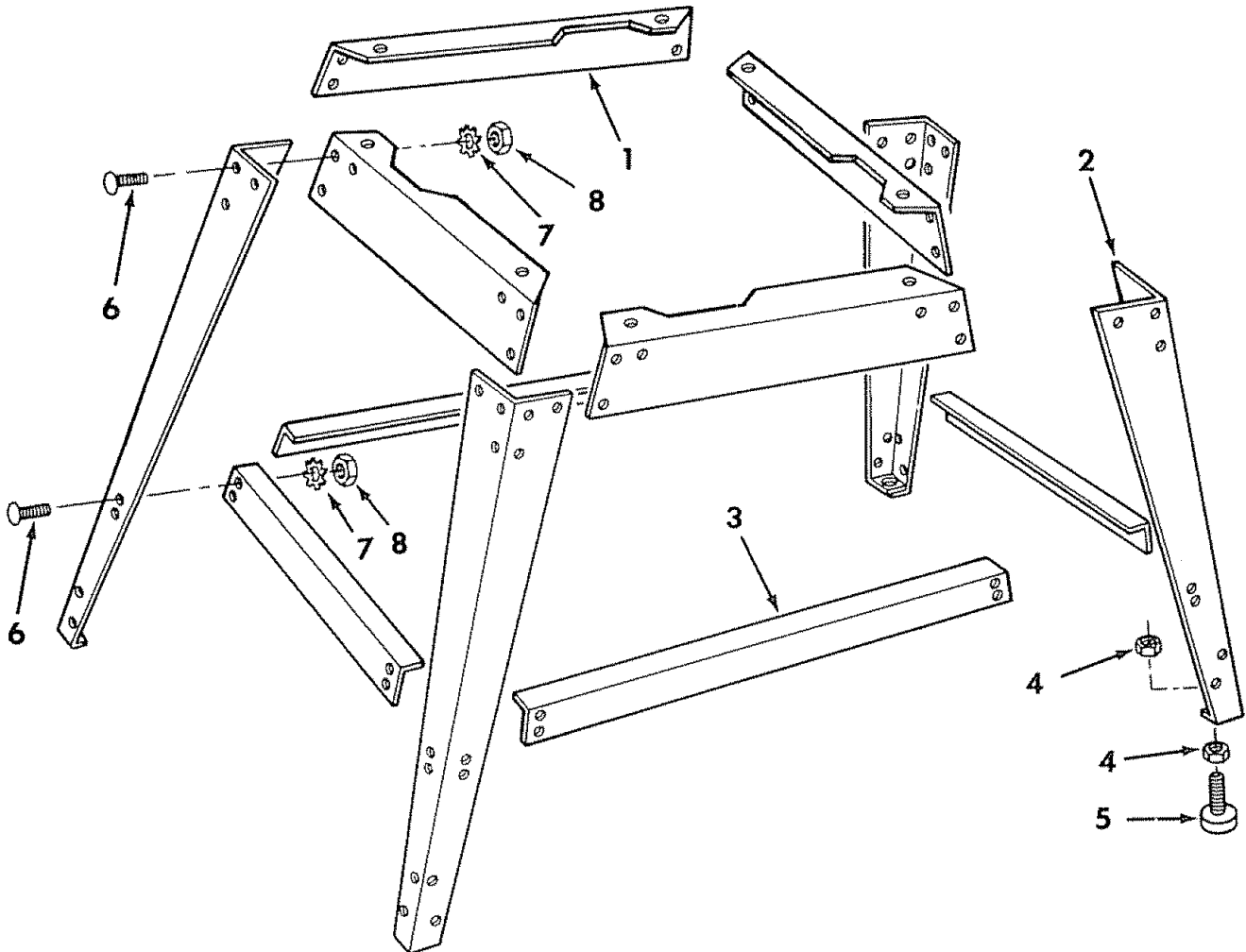

Key No.	Part No.	Description
1	815918	Stiffener, Leg
2	817105	Leg
3	815909	Stiffener, Lower
4	STD541237	*Nut, Hex Jam 3/8-16
5	803835-1	Foot, Leveling
6	805589-5	Screw Truss Hd. 1/4-20 x 1/2
7	STD551225	*Lockwasher, Int. 1/4
8	STD541025	*Nut, 1/4-20
—	507657	Bag of Loose Parts (Not. Ills.)

\*Standard Hardware Item may be Purchased Locally.







# SEARS

## owners manual

### SERVICE

### MODEL NO. 113.247440

ELECTRONIC BAND SAW  
WITH LEG SET

### HOW TO ORDER REPAIR PARTS

## 12-INCH ELECTRONIC BAND SAW

Now that you have purchased your 12-Inch Electronic Band Saw, should a need ever exist for repair parts or service, simply contact any Sears Service Center and most Sears, Roebuck and Co. stores. Be sure to provide all pertinent facts when you call or visit.

The model number of your 12-Inch Electronic Band Saw will be found on a plate attached to your saw, at the left-hand side of the base.

WHEN ORDERING REPAIR PARTS, ALWAYS GIVE THE FOLLOWING INFORMATION:

**PART NUMBER**

**PART DESCRIPTION**

**MODEL NUMBER**  
113.247440

**NAME OF ITEM**  
12-Inch Electronic Band Saw

All parts listed may be ordered from any Sears Service Center and most Sears stores. If the parts you need are not stocked locally, your order will be electronically transmitted to a Sears Repair Parts Distribution Center for handling.

Sold by SEARS, ROEBUCK AND CO., Chicago, IL. 60684 U.S.A.