

01 What's in the Box

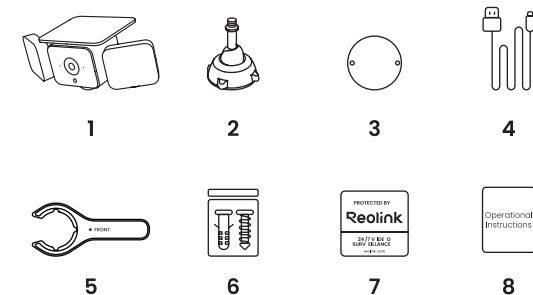

1. Camera
2. Mounting Bracket
3. Mounting Template
4. USB-C Cable
5. Mounting Wrench
6. Pack of Screws
7. Surveillance Sticker
8. Operational Instructions

02 Device Overview

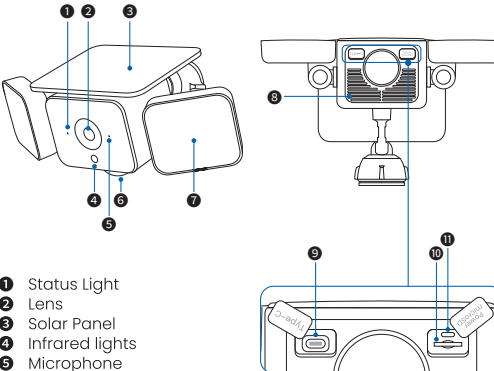

- 1 Status Light
- 2 Lens
- 3 Solar Panel
- 4 Infrared lights
- 5 Microphone
- 6 PIR Motion Sensor
- 7 Spotlight
- 8 Speaker
- 9 USB-C Port
- 10 microSD Card Slot
- 11 Power/Reset Button

Power Button Functions:

- Power on:** Press and hold the button for 2 seconds.
- Power off:** Press and hold the button for 5 seconds.
- Factory reset:** Triple-press the button while the camera is on.

03 Charging Instructions

For optimal performance, fully charge the battery before mounting the camera.

Use a power adapter (sold separately) to charge the battery.

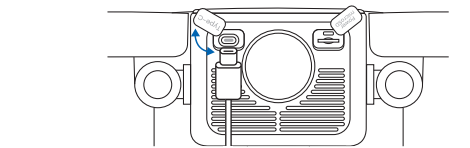

Always reseal the charging port with the rubber plug after charging to keep it weatherproof.

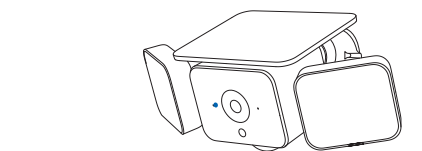

Charging Indicator:

- Blue flashing LED: Charging
- Solid blue LED: Fully charged

04 Initial Setup

01/Download the Reolink App



Download on the App Store

GET IT ON Google Play

02/Complete the Setup

Press and hold the power button to turn on the camera. Tap the + button in the top corner, scan the QR code and follow the on-screen instructions to complete the setup.

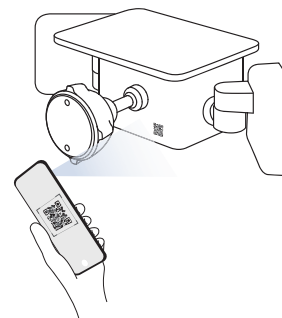
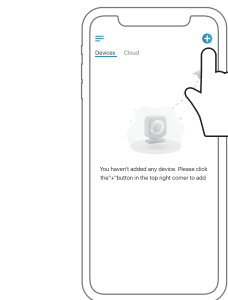
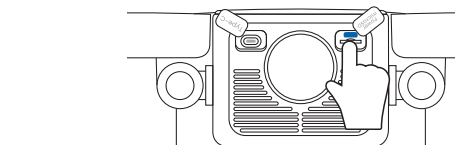

05 Installation Steps

01/Installation Tips

- Position the camera 2-3 meters (7-10 ft) above the ground to maximize the PIR motion sensor's detection range.
- For optimal detection, install the camera at an angle where movement crosses its detection zones.

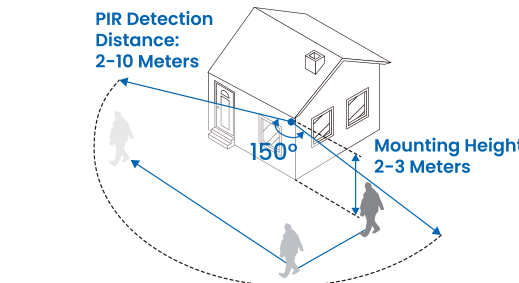

NOTE: If a subject moves straight toward the camera, the PIR sensor may fail to detect motion. It is recommended to select a location with good viewing angle through the Reolink APP before drilling and installation.

02/Installation Steps

1 Unscrew the back cover.

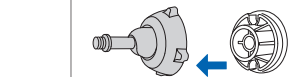

2 Drill holes and insert anchors.

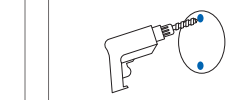

3 Install the base.

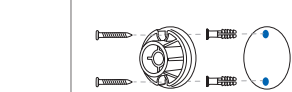

4 Tighten the base.

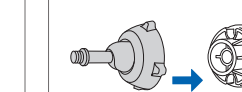

5 Mount the camera.

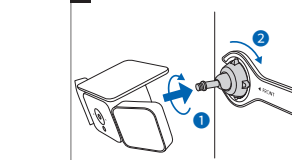

6 Adjust the angle.

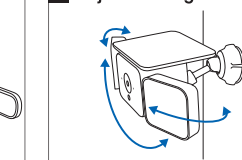

NOTE: Ensure the solar panel gets at least 1 hour of direct sunlight daily.

05 Specifications

Size: 101.5*264*161.2 mm
Weight: 721 g
Operating Temperature: -20°C to 55°C (-4°F to 131°F)
Charging Temperature: 0°C to 45°C (32°F to 113°F)
Operating Humidity: 10%~90%
Weather Resistance: IP66 certified weatherproof

For more specifications, visit <https://reolink.com/>.

06 Troubleshooting

Camera is Not Powering On

If your camera is not turning on, please apply the following solutions:

Charge the battery with a DC 5V/2A power adapter. When the blue light is on, the battery is fully charged.

If the problem is not solved, please contact Reolink Support.

Failed to Connect to Wi-Fi During Initial Setup Process

If the camera fails to connect to Wi-Fi, please try the following solutions:

- Ensure that you have entered the correct Wi-Fi password.
- Move the camera closer to your router to ensure a strong Wi-Fi signal.
- Change the encryption method of the Wi-Fi network to WPA2-MD5.



- PSK/WPA-PSK on your router interface.
- Change your Wi-Fi SSID or password and make sure that SSID is within 31 characters and password is within 64 characters.
- Set your password using only the characters available on the keyboard.

If the problem is not solved, please contact Reolink Support.

07 Important Safety Instructions

Please read the instructions carefully before using the camera. For tips on extending battery life, visit our support post: <https://support.reolink.com/hc/en-us/articles/360006991893>

1. Charge the battery with a standard and high-quality DC 5V battery charger or Reolink solar panel. It is not compatible with solar panels from any other brands.
2. Replace only with the same or equivalent type of equipment and accessories recommended by the manufacturer. Using an incorrect type poses an explosion risk.
3. Do not remove a built-in battery from the camera.
4. Charge the battery only in temperatures between 0°C and 45°C. And use it only in temperatures ranging from -20°C and 55°C.
5. Do not charge, use or store a battery camera near heat sources, such as space heaters, cooking surfaces, cooking appliances, irons, radiators, or fireplaces. Extreme heat may cause an explosion.
6. Do not expose the camera with a battery to extremely low air pressure environments, as this may cause an explosion.
7. Do not place the camera with a battery in hot wilderness areas or expose it to lightning, as this poses a risk of fire.

8. Do not hit or heavily compress the camera with a battery, as this poses a risk of fire or explosion.
9. Do not use the battery if it appears damaged, swollen, or compromised in any way (e.g., leaking, emitting odors, dented, corroded, rusted, cracked, swollen, melted, or scratched).
10. Keep the camera and battery away from children.
11. Do not ingest or swallow battery. If the battery is ingested or swallowed, it can cause severe internal burns and damage. Seek immediate medical attention if you suspect the battery has been ingested or placed inside any part of the body.
12. Do not attempt to disassemble, repair, or alter the camera or battery by yourself.
13. Keep the charging port dry, clean and free of any debris. Cover it with the rubber plug after the battery is fully charged.
14. Always follow the local safety laws and regulations when using the camera.
15. Always follow the local waste and recycling laws to dispose of used batteries.
16. The light source of this luminaire is not replaceable; when the light source reaches its end of life the whole luminaire shall be replaced.

08 Legal Disclaimer

To the maximum extent permitted by applicable law, this document and the product described, with its hardware, software, firmware, and services, are delivered on an "as-is" and "as-available" basis, with all faults and without warranty of any kind. Reolink disclaims all warranties, express or implied, including but not limited to, warranties of merchantability, satisfactory quality, fitness for a particular purpose, accuracy, and non-

infringement of third-party rights. In no event will Reolink, its directors, officers, employees, or agents be liable to you for any special, consequential, incidental or indirect damages, including but not limited to damages for loss of business profits, business interruption, or loss of data or documentation, in connection with the use of this product, even if Reolink has been advised of the possibility of such damages.

To the extent permitted by applicable law, your use of the Reolink products and services is at your sole risk and you assume all risks associated with internet access. Reolink does not take any responsibilities for abnormal operation, privacy leakage or other damages resulting from cyber attacks, hacker attacks, virus inspections, or other internet security risks. However, Reolink will provide timely technical support if required.

The laws and regulations related to this product vary by jurisdiction. Please check all relevant laws and regulations in your jurisdiction before using this product to ensure that your use conforms to the applicable law and regulation. During the use of the product, you must comply with relevant local laws and regulations. Reolink is not responsible for any illegal or improper use and its consequences. Reolink is not liable in the event that this product is used with illegitimate purposes, such as third-party rights infringement, medical treatment, safety equipment, or other situations where the product failure could lead to death or personal injury, or for weapons of mass destruction, chemical and biological weapons, nuclear explosion, and any unsafe nuclear energy uses or anti-humanity purposes. In the event of any conflicts between this manual and the applicable law, the latter prevails.

09 Notification of Compliance

FCC Statement

This device complies with Part 15 of the FCC Rules. Operation is subject to the following two conditions:

- (1) This device may not cause harmful interference, and
- (2) This device must accept any interference received, including interference that may cause undesired operation. Changes or modifications not expressly approved by the party responsible for compliance could void the user's authority to operate the equipment.

This equipment has been tested and found to comply with the limits for a Class B digital device, pursuant to Part 15 of the FCC Rules. These limits are designed to provide reasonable protection against harmful interference in a residential installation. This equipment generates uses and can radiate radio frequency energy and, if not installed and used in accordance with the instructions, may cause harmful interference to radio communications. However, there is no guarantee that interference will not occur in a particular installation. If this equipment does cause harmful interference to radio or television reception, which can be determined by turning the equipment off and on, the user is encouraged to try to correct the interference by one or more of the following measures:

- Reorient or relocate the receiving antenna.
- Increase the separation between the equipment and receiver.
- Connect the equipment into an outlet on a circuit different from that to which the receiver is connected.
- Consult the dealer or an experienced radio/TV technician for help.

FCC Radiation Exposure statement

This equipment complies with FCC radiation exposure limits set forth for an uncontrolled environment. This equipment should be installed and operated with minimum distance 20cm between the radiator & your body.

ISED Statement

This device complies with Industry Canada licence-exempt RSS standard(s). Operation is subject to the following two conditions: (1) this device may not cause interference, and (2) this device must accept any interference, including interference that may cause undesired operation of the device. This equipment should be installed and operated with a minimum distance of 20 cm between the radiator and your body.

Le présent appareil est conforme aux CNR d'Industrie Canada applicables aux appareils radio exempts de licence. L'exploitation est autorisée aux deux conditions suivantes : (1) l'appareil ne doit pas produire de brouillage, et (2) l'utilisateur de l'appareil doit accepter tout brouillage radioélectrique subi, même si le brouillage est susceptible d'en compromettre le fonctionnement. Cet équipement doit être installé et utilisé avec une distance minimale de 20 cm entre la source de rayonnement et votre corps.

MODIFICATION: Any changes or modifications not expressly approved by the grantee of this device could void the user's authority to operate the device.

MODIFICATION : les changements ou modifications non expressément approuvés par le fournisseur de licence de

l'appareil sont susceptibles d'annuler l'autorisation accordée à l'utilisateur de se servir de l'équipement.

This Class B digital apparatus complies with Canadian ICES-003. Cet appareil numérique de la classe B est conforme à la norme NMB-003 du Canada.

Operation of 5150-5350 MHz is restricted to indoor use only. Le fonctionnement de 5150-5350 MHz est limité à une utilisation en intérieur uniquement.

Hereby, REOLINK INNOVATION LIMITED declares that this device is in compliance with Cyber Security (Security Standards for Smart Devices) Rules 2025. For the Statement of Compliance, visit the Web site <https://reolink.com/product-compliance/>.

Limited Warranty

This product comes with a 2-year limited warranty that is valid only if purchased from Reolink Official Store or a Reolink authorized reseller. Learn more: <https://reolink.com/warranty-and-return/>.

NOTE: We hope that you enjoy the new purchase. But if you are not satisfied with the product and plan to return, we strongly suggest that you reset the camera to factory default settings and take out the inserted SD card before returning.

Terms and Privacy

Use of the product is subject to your agreement to the Terms of Service and Privacy Policy at reolink.com

Terms of Service

By using the Product Software that is embedded on the Reolink product, you agree to the terms&conditions between you and Reolink. Learn more: <https://reolink.com/terms-conditions/>

Technical Support

If you need any technical help, please visit our official support site and contact our support team before returning the products, <https://support.reolink.com>.

Trademarks Acknowledgement

"Reolink" and other Reolink's trademarks and logos are the properties of Reolink. Other trademarks and logos mentioned are the properties of their respective owners.

REOLINK INNOVATION LIMITED

FLAT/RM 705 7/F FA YUEN COMMERCIAL BUILDING 75-77 FA YUEN STREET MONG KOK KL HONG KONG