

Husqvarna

Operator Manual

MZ6128 / 966502301

MZ28ZT BF / 966582501

FD52M / 966582601

FD61M / 966582701

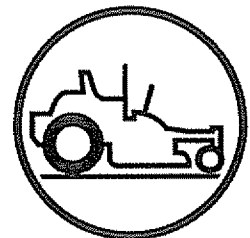

Please read the operator's manual carefully and make sure you understand the instructions before using the machine.

English

**To implement improvements, specifications and designs can be altered without prior notification.
Note that no legal demands can be placed based on the information contained in these instructions.
Use only original parts for repairs. The use of other parts voids the warranty.
Do not modify or install non-standard equipment to the unit without consent from the manufacturer.
Modifications to the unit may cause unsafe operations or damage the unit.**

**When this product is worn out and no longer used, it should
be returned to the reseller or other party for recycling.**

CONTENTS

INTRODUCTION	5	Stopping the Engine.....	31
Driving and Transport on Public Roads	5	Mowing Tips	32
Towing	5	Manual Transport.....	33
Operating	5	MAINTENANCE	34
Good Service	6	Battery	36
SYMBOLS AND DECALS	7	Safety System	37
SAFETY	9	Tire Pressures	37
Safety Instructions	9	Parking Brake	37
Personal Safety Equipment	11	Deck Belt	38
Slope Operation	11	Pump Belt	39
Safe Handling of Gasoline	13	V-belts	39
General Maintenance	14	Cutting Blades	40
Transport	16	Adjusting the Mower Deck	41
Towing	16	Leveling deck.....	41
Spark Arrestor	16	Anti-scalp rollers	42
CONTROLS	17	Caster Wheels	43
Control Locations	17	Hardware	43
Motion Control Levers	18	Cleaning	43
Hour Meter	19	LUBRICATION	44
Tracking	19	Lubrication Schedule	44
Parking Brake	20	Wheel and Deck Zerks	45
Blade Switch	20	Front Wheel Mount	45
Ignition Switch	20	Front Wheel Bearings	45
Fuses	21	Deck Spindles	45
Cutting Height Adjuster	22	Transaxle (Transmission) Fluid Change	46
Fuel Shut Off Valve	22	Purging Procedures	47
Refueling	23	TROUBLESHOOTING GUIDE	48
OPERATION	24	STORAGE	50
Training	24	Winter Storage	50
Steering	24	Service	50
Before Starting	25	WIRING DIAGRAMS	51
Starting the Engine	25	TECHNICAL DATA	52
Jumper Cables	28	Torque Specifications	55
Running	29	CONFORMITY CERTIFICATES	56
Operating on Hills	30	SERVICE JOURNAL	57



WARNING!

Failure to follow cautious operating practices can result in serious injury to the operator or other persons. The owner must understand these instructions, and must allow only trained persons who understand these instructions to operate the mower.

Each person operating the mower must be of sound mind and body and must not be under the influence of any mind altering substance.



WARNING!

Engine exhaust, some of its constituents, and certain vehicle components contain or emit chemicals known to the State of California to cause cancer and birth defects or other reproductive harm.



WARNING!

Battery posts, terminals and related accessories contain lead and lead compounds, chemicals known to the State of California to cause cancer and birth defects or other reproductive harm. Wash hands after handling.

INTRODUCTION

Congratulations

Thank you for purchasing a Husqvarna ride-on mower. This machine is built for superior efficiency to rapidly mow primarily large areas. A control panel that is easily accessible to the operator and a hydrostatic transmission regulated by steering controls both contribute to the machine's performance.

This manual is a valuable document. Read the contents carefully before using or servicing the machine. The following of instructions (use, service, maintenance) by all who operate this machine is important for the safety of the operator and others. It can also considerably increase the life span of the machine and increase its resale value.

If you sell your machine, be sure to give the operator's manual to the new owner.

The final chapter of this operator's manual provides a Service Journal. Ensure that service and repair work are documented. A well-kept service journal reduces service costs for the maintenance and affects the machine's resale value. Please contact your dealer for more information. Take the operator's manual along when the machine is taken to your dealer for service.

General

In this operator's manual, left and right, backward and forward are used in relation to the machine's normal driving direction.

Continuous dedication to improve our products require that specifications and design are subject to change without notice.

Driving and Transport on Public Roads

Check applicable road traffic regulations before transporting on public roads. If the machine is transported, you must always use approved fastening equipment and ensure that the machine is well anchored. DO NOT operate this machine on public roadways.

Towing

If machine is equipped with a tow hitch, use extreme caution when towing. Never allow children or others in or on the towed equipment. Make wide turns to avoid jack-knifing. Travel slowly and allow extra distance to stop.

Do not tow on sloped ground. The weight of the towed equipment may cause loss of traction and loss of control.

Follow the manufacturer's recommendation for weight limits for towed equipment. Do not tow near ditches, canals, and other hazards.

Operating

This machine is constructed only for mowing grass on lawns and even ground without obstacles such as stones, tree stumps, etc. The machine can also be used for other tasks when equipped with special accessories provided by the manufacturer. Operating instructions for the accessories are provided with delivery. All other types of uses are incorrect. The manufacturer's directions concerning operation, maintenance, and repairs must be carefully followed.

Lawn mowers and all power equipment can be potentially dangerous if used improperly. Safety requires good judgment, careful use in accordance with these instructions and common sense.

The machine must only be operated, maintained, and repaired by persons familiar with the machine's special characteristics and who are also knowledgeable about the safety instructions. Use only approved repair parts to maintain this machine.

Accident prevention regulations, other general safety regulations, occupational safety rules, and traffic regulations must be followed without fail.

Unauthorized modifications to the design of the machine may absolve the manufacturer from liability for any resulting personal injury or property damage.

INTRODUCTION

Good Service

Husqvarna's products are sold all over the world and only in specialized retail stores with complete service. This ensures that you as a customer receive only the best support and service. Before the product is delivered, the machine has, for example, been inspected and adjusted by your retailer. See the certificate in the Service Journal in this operator's manual.

When you need spare parts or support in service questions, warranty issues, etc., please consult the following professional:

This manual belongs to the machine with the manufacturing number:	Engine	Transmission

Manufacturing Number

The machine's manufacturing number can be found on the printed plate affixed to the engine compartment.

Stated on the plate, from the top are:

1. The machine's type designation (I.D.).
2. The manufacturer's type number (Model).
3. The machine's serial number (Serial no.)

Please have the type designation and serial number available when ordering spare parts.

The engine's manufacturing number is stamped on one of the valve covers.

The plate states:

4. The engine's model.
5. The engine's type.
6. Code

Please have these available when ordering spare parts.

The wheel motors and hydrostatic pumps have a barcode decal affixed at the rear.

SYMBOLS AND DECALS

These symbols are found on the machine and in the operator's manual.

Study them carefully so that you know what they mean.



WARNING!
 XXXX XXXXXX XXXXX XXXX XXXXXXXXXXXX
 XXXXXX XXXXXXXXXXXX. XX XXXXXXXXXXX XXXX
 XXXXXX.

Used in this publication to notify the reader of a risk of **personal injury or death**, particularly if the reader should neglect to follow instructions given in the manual.

IMPORTANT INFORMATION
 XXXX XXXXXX XXXXX XXXX XXXXXXXXXXXX XXXXXX
 XXXXXXXXXXXX. XX XXXXXXXXXXX XXXX XXXXXX.

Used in this publication to notify the reader of a risk of **material damage**, particularly if the reader should neglect to follow instructions given in the manual. Used also when there is a potential for misuse or misassembly.



Reverse



Neutral



Fast



Slow



Fuel



Warning!



Parking Brake



CE conformity marking Only for European market

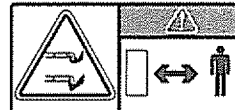

Warning! Rotating blades, keep away from the discharge deck



Do not touch parts



Battery acid is corrosive, explosive and flammable



Do not stand here

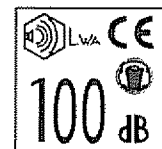

Noise emissions to the surroundings in accordance with the European Union's directive. The machine's emission is stated in the chapter TECHNICAL DATA and on the decals. Only machines for European market



Use protective glasses



Use protective gloves



SYMBOLS AND DECALS

Read
Operator's
Manual

Shut off engine and
remove key before
performing any
maintenance or repair work

Keep a safe
distance from
the machine

Use on slopes
no greater
than 10°

No passengers

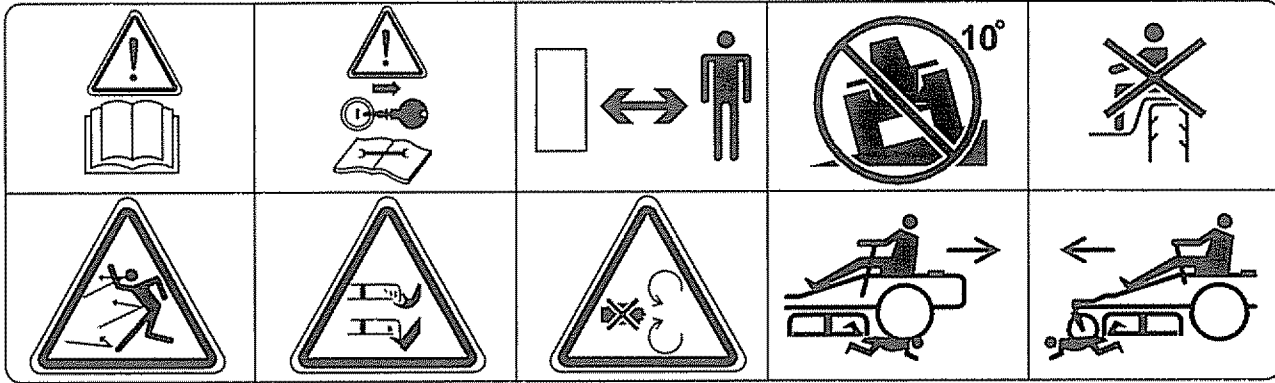

Whole body
exposure to
thrown objects

Severing of fingers
and toes

Do not open or
remove safety
shields while
engine is running

Careful backing up.
watch for other
people

Careful going
forward, watch for
other people



Moving sharp blades under cover

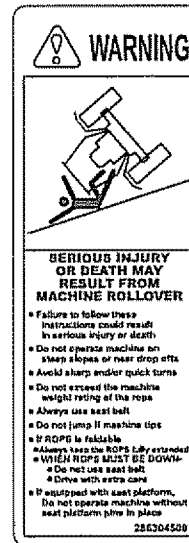

SAFETY

Safety Instructions

These instructions are for your safety. Read them carefully.



WARNING!

This symbol means that important safety instructions need to be emphasized. It concerns your safety.

IMPORTANT: THIS CUTTING MACHINE IS CAPABLE OF AMPUTATING HANDS AND FEET AND THROWING OBJECTS. FAILURE TO OBSERVE THE FOLLOWING SAFETY INSTRUCTIONS COULD RESULT IN SERIOUS INJURY OR DEATH

General Operation

- Read, understand, and follow all instructions on the machine and in the manual before starting
- Do not put hands or feet near rotating parts or under the machine. Keep clear of the discharge opening at all times
- Only allow responsible adults, who are familiar with the instructions, to operate the machine.
- Clear the area of objects such as rocks, toys, wire, etc., which could be picked up and thrown by the blades.
- Be sure the area is clear of bystanders before operating. Stop machine if anyone enters the area.
- Never carry passengers. The machine is only intended for use by one person.
- Do not mow in reverse unless absolutely necessary. Always look down and behind before and while backing.
- Never direct discharged material toward anyone. Avoid discharging material against a wall or obstruction. Material may ricochet back toward the operator. Stop the blades when crossing gravel surfaces.
- Do not operate machine without the entire grass catcher, discharge guard, or other safety devices in place and working
- Slow down before turning.
- Never leave a running machine unattended. Always turn off blades, set parking brake, stop engine, and remove keys before dismounting.
- Disengage blades when not mowing. Shut off engine and wait for all parts to come to a complete stop before cleaning the machine, removing the grass catcher, or unclogging the discharge guard.
- Operate machine only in daylight or good artificial light.
- Do not operate the machine while under the influence of alcohol or drugs.

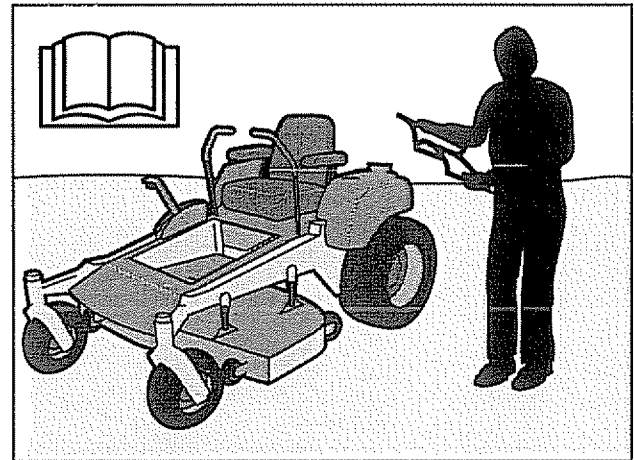

8011-512

Read the operator's manual before starting the machine

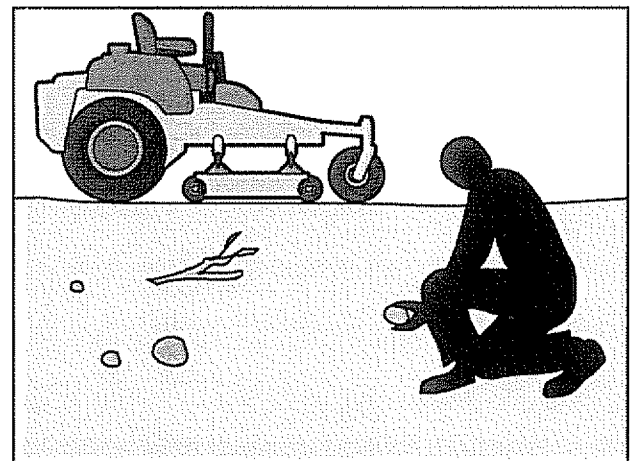

8011-513

Clear the area of objects before mowing

SAFETY

- Watch for traffic when operating near or crossing roadways.
- Use extra care when loading or unloading the machine into a trailer or truck.
- Always wear eye protection when operating machine.
- Data indicates that operators age 60 years and above are involved in a large percentage of riding mower-related injuries. These operators should evaluate their ability to operate the riding mower safely enough to protect themselves and others from serious injury.
- Follow the manufacturer's recommendation for wheel weights or counterweights
- Anyone who operates this machine must first read and understand this Operation Manual. Local laws may regulate the age of the user.
- Keep machine free of grass, leaves or other debris buildup which can touch the hot exhaust or engine parts and burn. Do not allow the mower deck to plow leaves or other debris, causing buildup to occur.
- Clean any oil or fuel spillage before operating or storing the machine.
- Allow machine to cool before storage

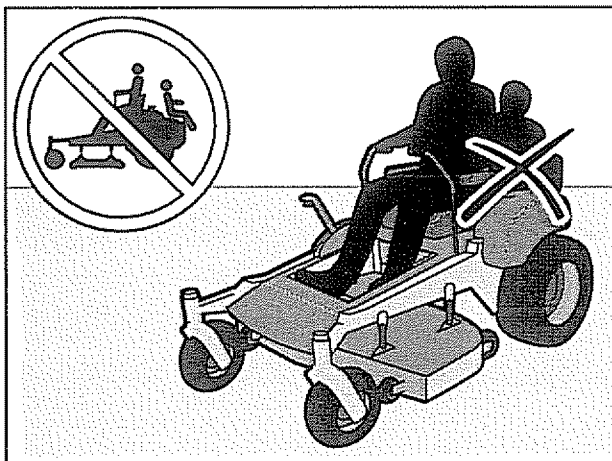

8011-520

Never take passengers



WARNING!

Engine exhaust and certain vehicle components contain or emit chemicals considered to cause cancer, birth defects, or other reproductive system damage. The engine exhaust contains carbon monoxide, which is an odorless, colorless, poisonous gas. Do not use the machine in enclosed spaces.

SAFETY

Personal Safety Equipment



WARNING!

When using the machine, approved personal protective equipment (shown in illustrations) shall be used. Personal protective equipment cannot eliminate the risk of injury but it will reduce the degree of injury if an accident does happen. Ask your retailer for help in choosing the right equipment.

- Make sure that you have first aid equipment close at hand when using the machine.
- Never use the machine when barefoot.
- Always wear protective shoes or boots, preferably with steel toe caps.
- Always wear approved protective glasses or a full visor when assembling or driving.
- Always wear gloves when handling the blades.
- Never wear loose clothing that can get caught in moving parts.
- Use ear protectors to avoid damage to hearing.

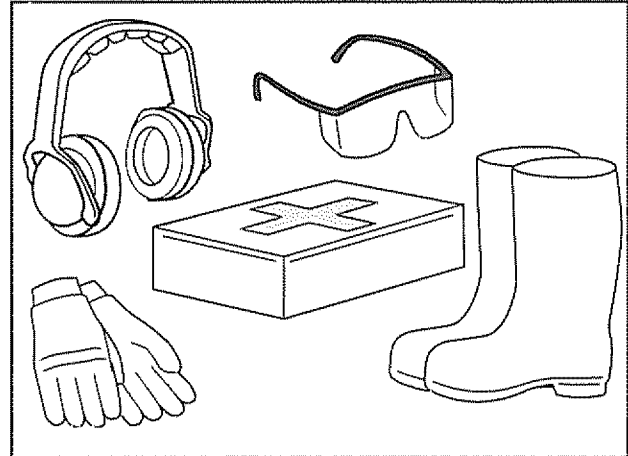

Personal protective equipment

6011-670e

Slope Operation

Slopes are a major factor related to loss of control and tip-over accidents, which can result in severe injury or death. Operation on all slopes requires extra caution. If you cannot back up the slope or if you feel uneasy on it, do not mow it.

- Mow up and down slopes (10 degrees maximum), not across.
- Watch for holes, ruts, bumps, rocks, or other hidden objects. Uneven terrain could overturn the machine. Tall grass can hide obstacles.
- Choose a low ground speed so that you will not have to stop while on the slope.
- Do not mow on wet grass. Tires may lose traction.
- Avoid starting, stopping, or turning on a slope. If the tires lose traction, disengage the blades and proceed slowly straight down the slope.
- Keep movement on the slopes slow and gradual. Do not make sudden changes in speed or direction, which could cause machine to roll over.
- Use extra care while operating machine with grass catchers or other attachments; they can affect the stability of the machine.
- Do not use on steep slopes.
- Do not try to stabilize the machine by putting a foot on the ground.
- Do not mow near drop-offs, ditches, or embankments. The machine could suddenly roll over if a wheel is over the edge or if the edge caves in.

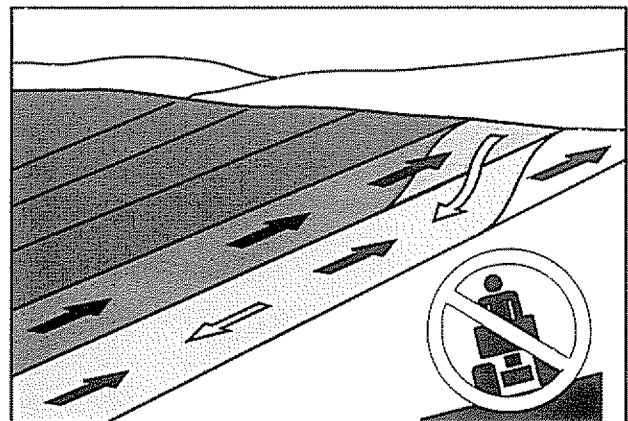

Mow up and down, not side to side

6003-004



WARNING!

Do not drive up or down hills with slopes greater than 10 degrees. Do not drive across any slopes.

SAFETY

Children

Tragic accidents can occur if the operator is not alert to the presence of children. Children are often attracted to the machine and the mowing activity. *Never* assume that children will remain out of the path of danger.

- Keep children out of the mowing area and in the watchful care of a responsible adult other than the operator.
- Be alert and turn machine off if a child enters the area.
- Before and while backing, look behind and down for small children.
- Never carry children, even with the blades shut off. They may fall off and be seriously injured or interfere with safe machine operation. Children who have been given rides in the past may suddenly appear in the mowing area for another ride and be run over or backed over by the machine.
- Never allow children to operate the machine.
- Use extra care when approaching blind corners, shrubs, trees, or other objects that may block the view of a child.

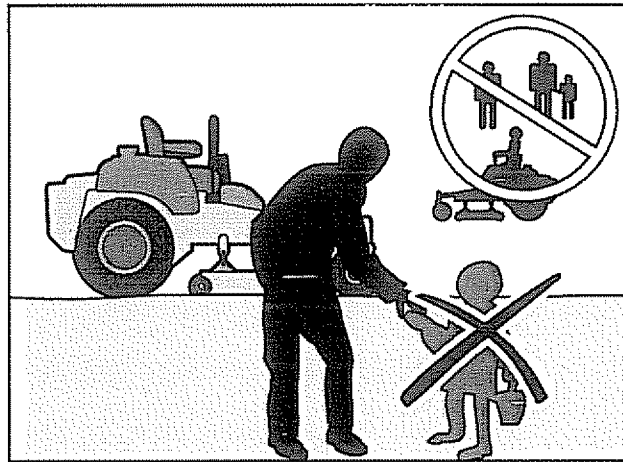

8011-516

Keep children away from work area

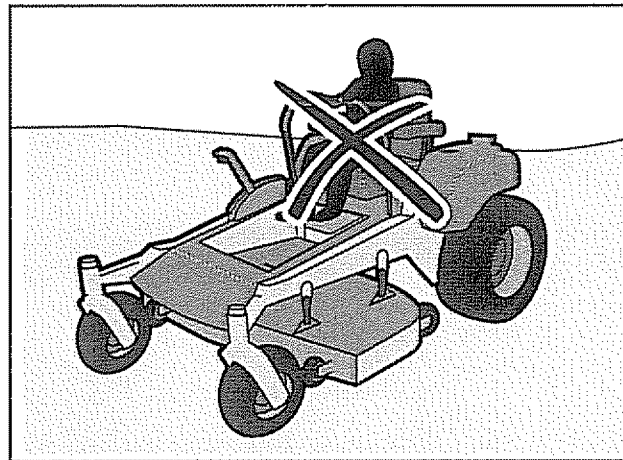

8011-517

Never allow children to operate the machine

SAFETY



WARNING!

The engine must not be started when the driver's floor plate or any protective plate for the mower deck's drive belt is removed.

Safe Handling of Gasoline

To avoid personal injury or property damage, use extreme care in handling gasoline. Gasoline is extremely flammable and the vapors are explosive.

- Extinguish all cigarettes, cigars, pipes, and other sources of ignition.
- Use only approved gasoline container.
- Never remove gas cap or add fuel with the engine running. Allow engine to cool at least two (2) minutes before refueling.
- Never fuel the machine indoors.
- Never store the machine or fuel container where there is an open flame, spark, or pilot light such as on a water heater or other appliance.
- Before beginning to refuel, minimize the risk of static electricity by touching a metal surface.
- Never fill containers inside a vehicle or on a truck or trailer bed with plastic liner. Always place containers on the ground away from the vehicle when filling.
- Remove gas-powered equipment from the truck or trailer and refuel it on the ground. If this is not possible, refuel such equipment with a portable container, rather than from a gasoline dispenser nozzle.
- Keep the nozzle in contact with the rim of the fuel tank or container opening at all times until fueling is complete. Do not use a nozzle lock-open device.
- If fuel is spilled on clothing, change clothing immediately.
- Never overfill fuel tank. Replace gas cap and tighten securely.
- Do not start the engine near spilled fuel.
- Never use gasoline as a cleaning agent.
- If leaks arise in fuel system, engine must not be started until problem has been resolved.
- Check the fuel level before each use and leave space for the fuel to expand, as the heat from the engine and the sun may otherwise cause the fuel to expand and overflow.

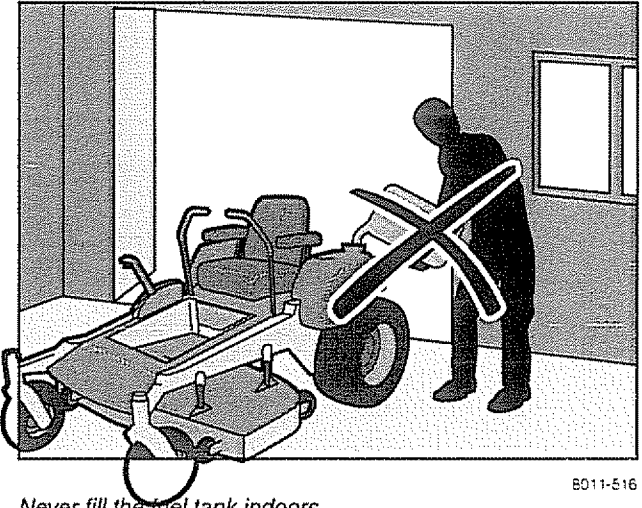

Never fill the fuel tank indoors

B011-516



WARNING!

The engine and the exhaust system become very hot during operation.

There is risk for burns if touched.

Allow engine and exhaust system to cool at least two (2) minutes before refueling.

SAFETY

General Maintenance

- Never operate machine in a closed area
- Keep all nuts and bolts tight to be sure the equipment is in safe working condition.
- Never tamper with safety devices. Check their proper operation regularly.
- Keep machine free of grass, leaves, or other debris buildup. Clean oil or fuel spillage and remove any fuel-soaked debris. Allow machine to cool before storing.
- If the machine strikes a foreign object, stop and inspect the machine. Repair, if necessary, before restarting.
- Never make any adjustments or repairs with the engine running.
- Check grass catcher components and the discharge guard frequently and replace with manufacturer's recommended parts, when necessary.
- Mower blades are sharp. Wrap the blade or wear gloves, and use extra caution when servicing them.
- Check brake operation frequently. Adjust and service as required.
- Maintain or replace safety and instruction labels, as necessary.
- Do not modify safety equipment. Check regularly to be sure it works properly. The machine must not be driven with defective or unmounted protective plates, protective cowlings, safety switches, or other protective devices.
- Do not change the settings of governors and avoid running the engine with overly high engine speeds. If the engine runs too fast, there is risk for damaging the machine components.
- Be very careful when handling battery acid. Acid on skin can cause serious corrosive burns. If battery acid is spilled on skin, rinse immediately with water.
- Acid in the eyes can cause blindness, contact a doctor immediately.
- Be careful when servicing the battery. Explosive gases form in the battery. Never perform maintenance on the battery when smoking or near open flames or sparks.
- The battery can explode and cause serious injury or damage.
- Ensure that the equipment is in good condition and that all nuts and bolts, especially those fastening the blade attachments, are properly tightened and torqued.

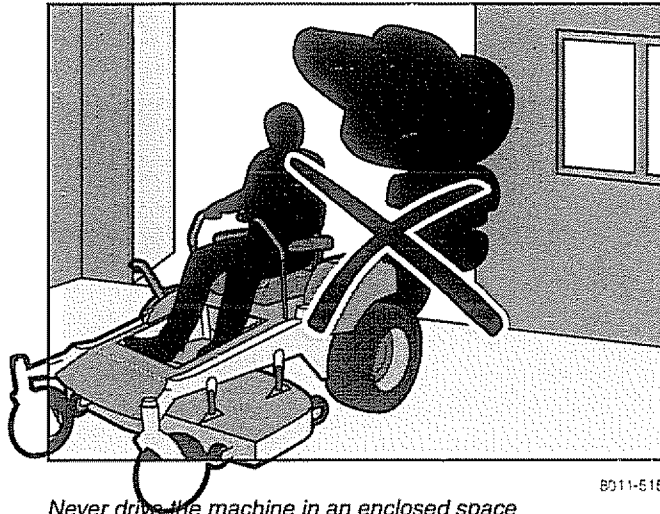

Never drive the machine in an enclosed space

B311-515



WARNING!

Use protective glasses for maintenance work.



WARNING!

The battery contains lead and lead compounds, chemicals that are considered to cause cancer, birth defects, and other reproductive system damage. Wash your hands after handling the battery.

SAFETY

Sparking can occur when working with the battery and the heavy cables of the starter circuit. This can cause battery explosion, fire or eye injury. Sparking in this circuit can not occur after the chassis cable (normally negative, black) is removed from the battery.

- Use protective goggles.
- Ensure that the fuel filler cap is mounted tightly and no flammable substances are stored in an open vessel.



WARNING!

Avoid electrical sparking and its consequences by the following routines:

- Never work with the starter circuit if there is spilled fuel.
- Disconnect the negative cable from the battery first and reconnect it last.
- Do not make a bridge short circuit across the starter relay to run the starter.
- Never use the machine indoors or in spaces lacking proper ventilation. The exhaust fumes contain carbon monoxide, an odorless, poisonous, and lethal gas.
- Stop to inspect the equipment if the machine runs over or into anything. If necessary, make repairs before starting.
- Never make adjustments with the engine running.
- The machine is tested and approved only with the equipment originally provided or recommended by the manufacturer. Only use approved repair parts for the machine.
- The blades are sharp and can cause cuts and gashes. Wrap the blades or use protective gloves when handling them.
- Check the parking brake's functionality regularly. Adjust and service as necessary.
- The mulch blades should only be used in familiar areas when higher quality mowing is desired.
- Reduce the risk of fire by removing grass, leaves, and other debris that may have accumulated on the machine.
- Allow the machine to cool before putting it in storage.
- Regularly clean deck and underside of deck, avoid spraying engine and electrical components with water.

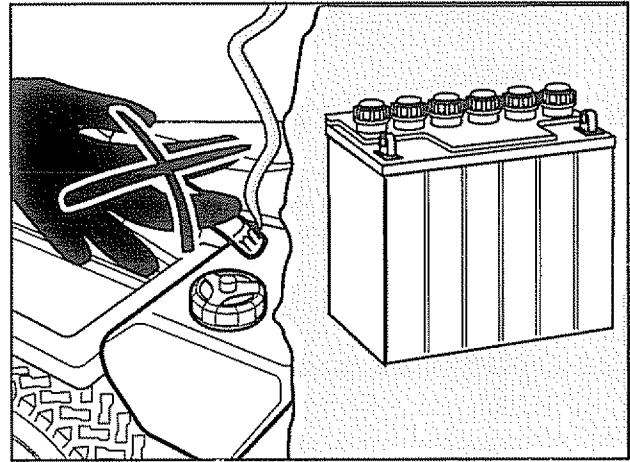

8003-009

Do not smoke when performing maintenance on the battery. The battery can explode and cause serious injury/damage.

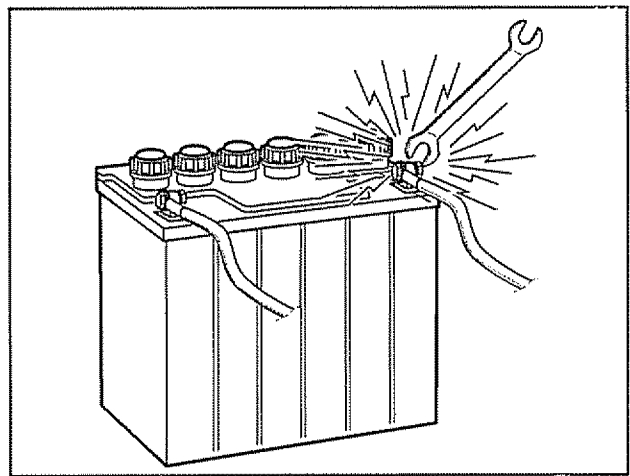

8003-726

Risk of sparking

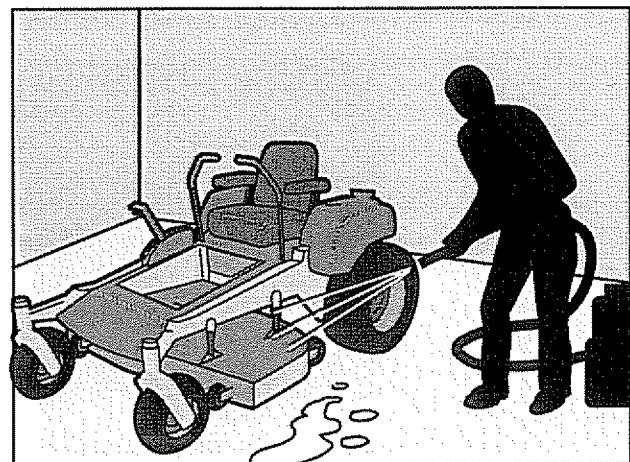

8011-514

Regularly clean deck

SAFETY

Transport

- The machine is heavy and can cause serious crushing injuries. Be extra cautious when it is loaded on or unloaded from a vehicle or trailer.
- Use an approved trailer to transport the machine. Activate the parking brake, turn off the fuel supply, and fasten the machine with approved fastening devices, such as bands, chains, or straps, when transporting.
- Do not operate this machine on public roadways.
- Check and abide by local traffic regulations before transporting the machine on any road.
- Do not tow this machine: it may cause damage to the drive system.
- Load the unit onto truck or trailer by driving up ramps of suitable strength using a slow speed. Do not lift! The machine is not intended to be lifted by hand.

Towing

If machine is equipped with a tow hitch, use extreme caution when towing. Never allow children or others in or on towed equipment.

Make wide turns to avoid jack-knifing. Travel slowly and allow extra distance to stop. Do not tow on sloped ground. The weight of the towed equipment may cause loss of traction and loss of control.

Follow the manufacturer's recommendation for weight limits for towed equipment. Do not tow near ditches, canals, and other hazards.

Spark Arrestor

A spark arrestor for the muffler is available through your authorized Husqvarna dealer.



WARNING!

Escaping hydraulic oil under pressure can have sufficient force to penetrate the skin, causing serious injury. If injured by escaping fluid, see a doctor at once. Serious infection or reaction can develop if proper medical treatment is not administered immediately.

IMPORTANT INFORMATION

The parking brake is not sufficient to lock the machine in place during transport. Ensure that the machine is well fastened to the transport vehicle. Always reverse the machine onto the transport vehicle to avoid tipping it over.



WARNING!

This mower is equipped with an internal combustion engine and should not be used on or near any unimproved forested, bush covered or grassy lands unless the engine's system is equipped with a spark arrestor meeting applicable local or state laws (if any).

CONTROLS

This operator's manual describes the Husqvarna Zero Turn Rider. The rider is fitted with a Briggs & Stratton four-stroke overhead valve engine developing 28 horse power*

Transmission from the engine is made via belt-driven hydraulic pumps. Using the left and right steering controls, the flow is regulated and thereby the direction and speed.

Control Locations

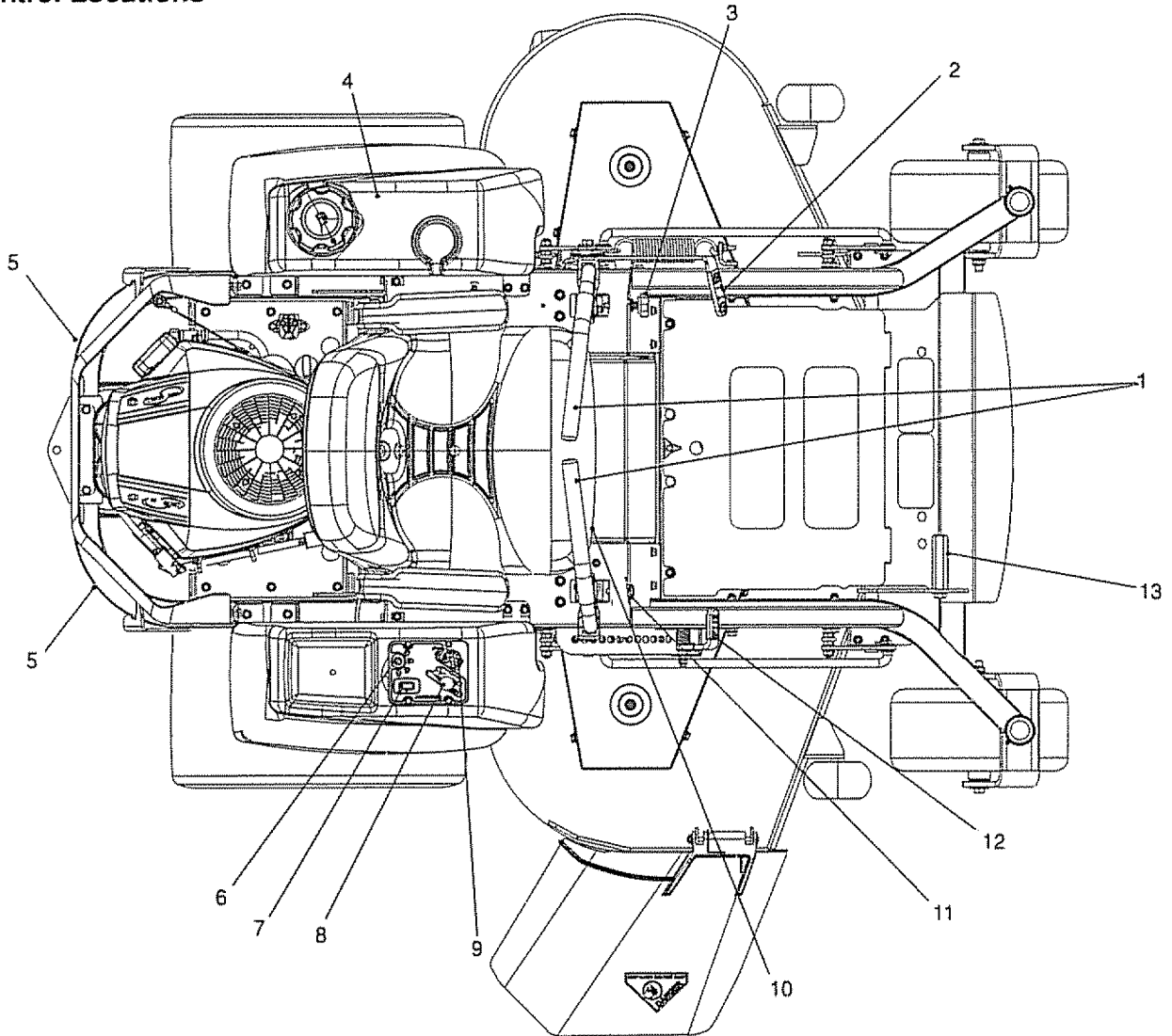

5056-039

- | | | |
|--------------------------|---------------------|---------------------------|
| 1. Motion control levers | 6. Ignition switch | 10. Seat adjustment lever |
| 2. Parking brake | 7. Hour meter | 11. Right tracking bolt |
| 3. Tracking knob | 8. Throttle control | 12. Height adjustment |
| 4. Fuel tank | 9. Blade switch | 13. Deck lift |
| 5. Hydro release levers | | |

**The power rating of the engines indicated is the average net power output (at specified rpm) of a typical production engine for the engine model measured to SAE standard J1349/ISO1585. Mass production engines may differ from this value. Actual power output for the engine installed in the final machine will depend on the operating speed, environmental conditions and other variables.*

CONTROLS

Motion Control Levers

The machine's speed and direction are continuously variable using the two steering controls. The steering controls can be moved forward or backward about a neutral position. Furthermore, there is a neutral position, which is locked if the steering controls are moved outward.

When both controls are in the neutral position (N), the machine stands still.

By moving both controls an equal amount forward or backward, the machine moves in a straight line forward or backward respectively.

For example, to turn right while moving forward, move the right control towards the neutral position. The rotation of the right wheel is reduced and the machine turns to the right.

Zero turn can be achieved by moving one control backward (behind the neutral position) and carefully moving the other steering control forward from its neutral position. The rotation direction when zero turning is determined by which steering control is moved backward behind the neutral position. If the left steering control is pulled backward, the machine turns to the left. Use extra care when using this maneuver.

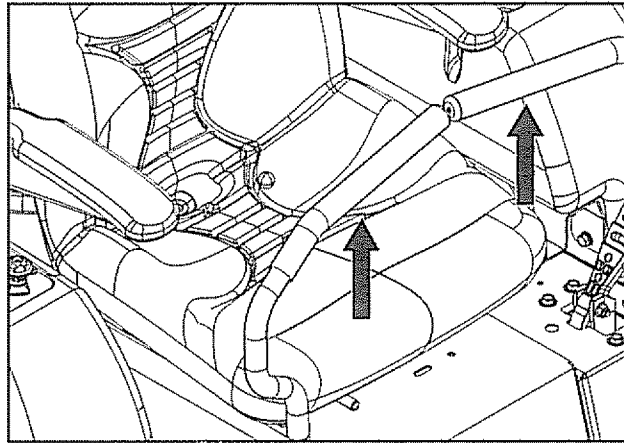

8056-042

Steering controls



WARNING!

The machine can turn very rapidly if one steering control is moved much further forward than the other.

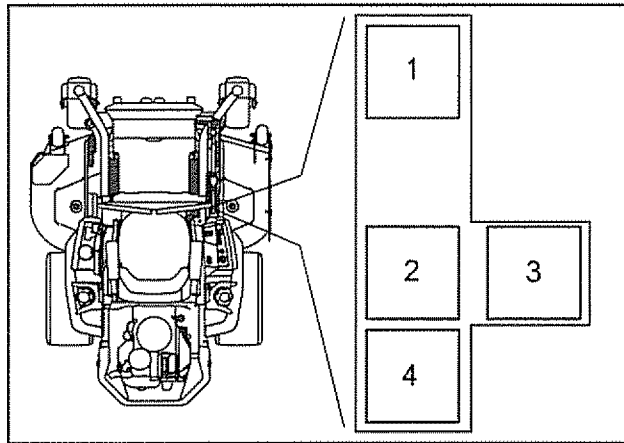

8065-053

- 1 Forward
- 2 Neutral
- 3 Neutral slot. Neutral lock
- 4 Reverse

Motion control lever pattern (right side)

CONTROLS

Hour Meter

The hour meter displays the total operating time. It will flash CHG OIL (Change Oil) at 50 hour intervals. The flash duration is one hour before and one hour after the interval. The CHG OIL icon will come on and shut off automatically. The hour meter cannot be manually reset.

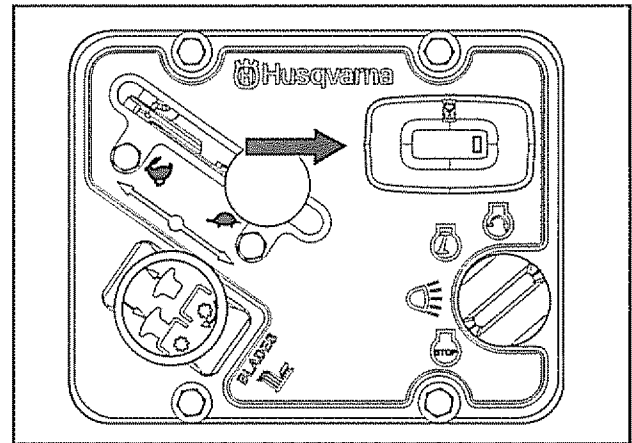

6056-043

Hour meter

Tracking

If the mower is not tracking straight, check the air pressure in both rear tires. Recommended air pressure for the rear tires is 15 psi (1 bar)

- 1 Tracking adjustments are made using the tracking knob. The tracking knob acts as limiting device for the motion control levers when in the full-forward position.
- 2 For preliminary tracking adjustment, move unit to an open, unobstructed area such as an empty parking lot or open field.
- 3 Rotating the tracking knob allows fine tuning adjustments so the machine tracks straight with the steering control levers in the full forward position.
- 4 Rotate the knob clockwise (as viewed from the operation position) to increase the speed on the left lever. Rotate counter clockwise to decrease speed.

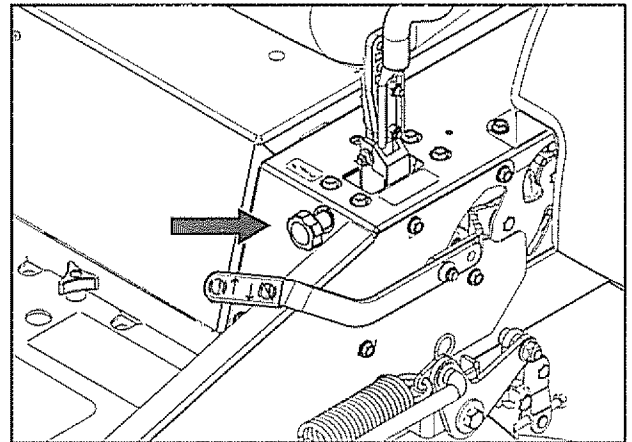

6056-044

Tracking adjustment

CONTROLS

Parking Brake

The parking brake is found on the left of the machine. Pull the lever backward to activate the brake and push forward to release it.

IMPORTANT INFORMATION

The machine must stand absolutely still when applying the parking brake. Always set the parking brake before dismounting. Release the parking brake before moving the mower.

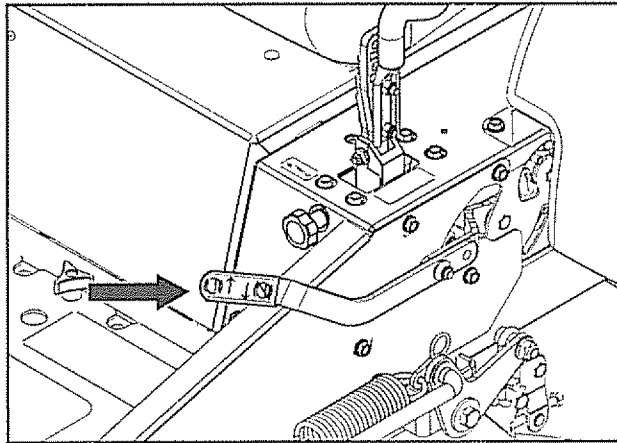

Parking brake

8058-044

Blade Switch

To engage the mower deck, pull the blade switch knob out. The mower blades are disengaged when the knob is pressed down fully.

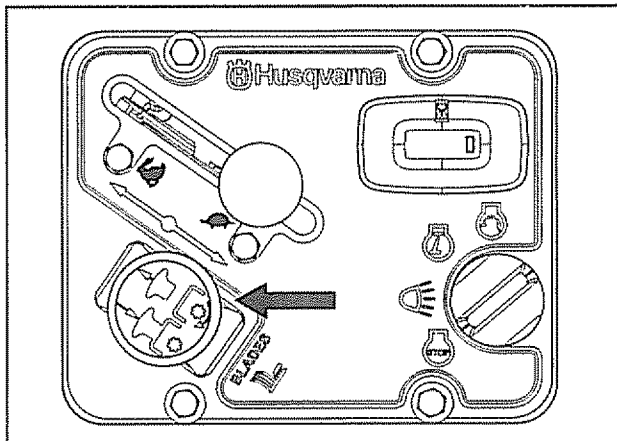

Blade switch

8058-043

Ignition Switch

The ignition key is placed on the control panel and is used to start and stop the engine.

Turn the key clockwise to start the engine.

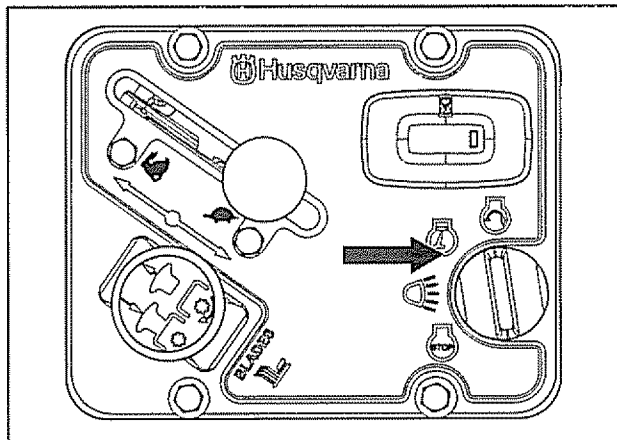

Ignition switch

8058-043

CONTROLS

Release the key to the RUN position when the engine has started.

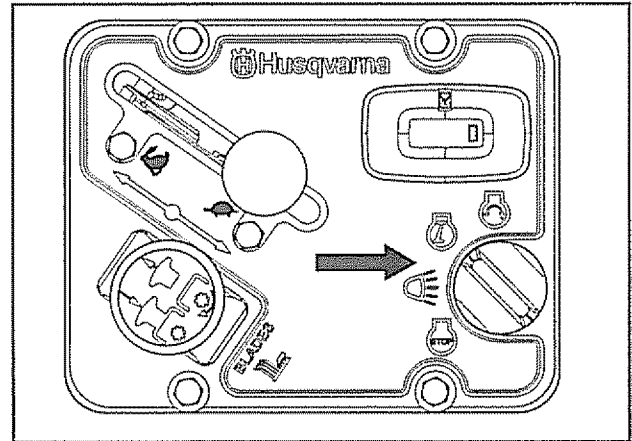

8056-046

Ignition switch - RUN position

For using "accessory", turn the key counter clockwise

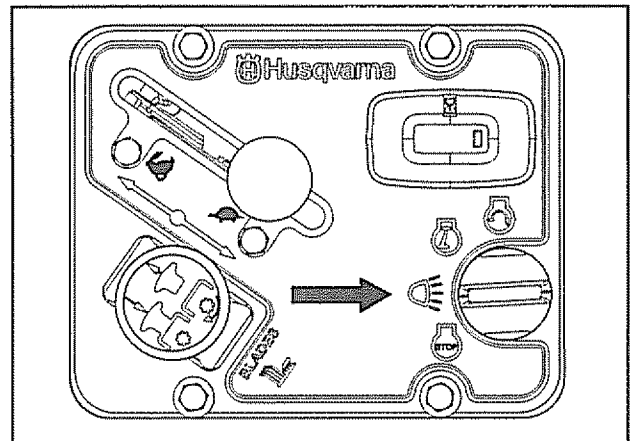

8066-005

Ignition switch - accessory

Fuses

Fuses are located on the left hand side of the machine. They are accessed by tilting the seat forward. Fuses are flat pin fuses type as used in automobiles.

There are two fuses with ratings and functions:

1. 20 A, Primary fuse
2. 7.5 A, Mower deck coupling

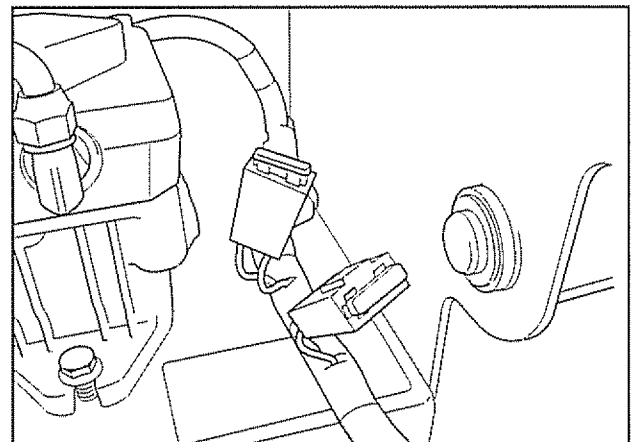

8011-420

Fuses

CONTROLS

Cutting Height Adjuster

The desired cutting height is set with the height pin. The cutting height pedal releases the deck lift to place the deck and the selected height.

For transport, push the lift pedal fully forward until the deck lift latches in the transport (highest) position.

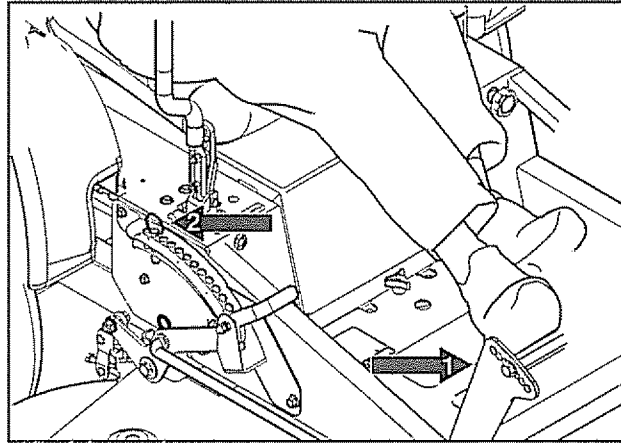

8065-017

1. Release pedal
 2. Height pin
- Cut height selection pedals*

Seat Adjustment Lever

The seat can be adjusted lengthways. When making adjustments, the lever under the front edge of the seat is moved to the left (as seen by the driver in the seat), after which the seat can be moved backward or forward.

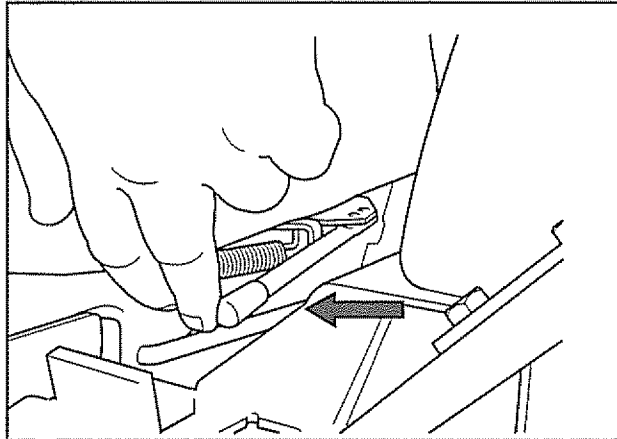

8011-441

Lengthways adjustment

Fuel Shut Off Valve

The fuel shut off valve is centered behind the rear of the seat. The valve is off when the handle tab is turned **perpendicular** to the fuel line.

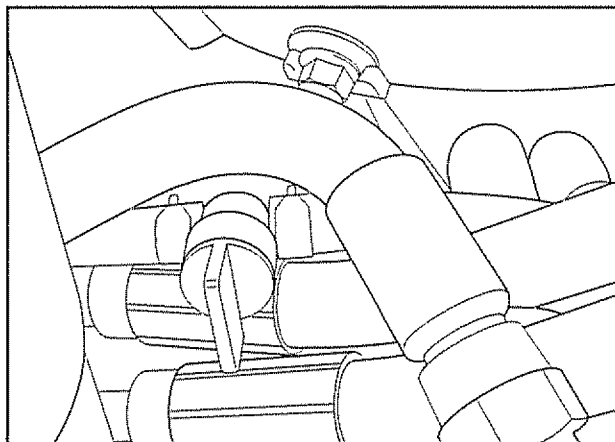

8565-010

Fuel shut off valve in the CLOSED position.

CONTROLS

Refueling

Read the safety instructions before refueling. The capacity for the tank is 5 gallons (19 liters)

Regularly check the gas cap gasket for damage and keep the cap properly tightened.

The engine will run on a minimum of 87-octane unleaded gasoline (no oil mix). Environmentally adapted alkylate gasoline can be used. See Technical Data concerning ethanol fuel. Methanol fuel is not allowed. Do not use E85 alcohol based fuel. Damage to the engine and components may occur.

When operating in temperatures below 32° F. (0° C), use fresh, clean winter grade gasoline to help insure good cold weather starting.

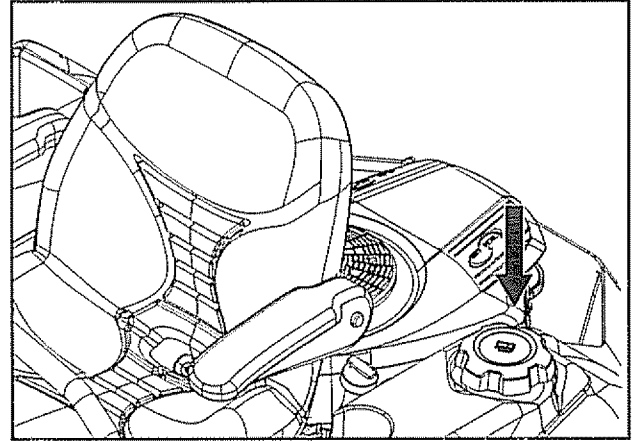

B065-007

Gasoline fuel tank



WARNING!

Gasoline is highly flammable. Observe caution and fill the tank outdoors (see the safety instruction).



WARNING!

The engine and the exhaust system become very hot during operation. Risk for burns if touched. Allow engine and exhaust system to cool at least two (2) minutes before refueling



WARNING!

Fill to bottom of filler neck. Do not overfill. Wipe off any spilled oil or fuel. Do not store, spill or use gasoline near an open flame.

IMPORTANT INFORMATION

Experience indicates that alcohol blended fuels (called gasohol, ethanol or methanol) can attract moisture which leads to separation and formation of acids during storage. Acidic gas can damage the fuel system of an engine while in storage. To avoid engine problems, the fuel system should be emptied before storage of 30 days or longer. Drain the gas tank, start the engine and let it run until the fuel lines and carburetor are empty. Use fresh fuel the next season. See *Storage Instructions* for additional information. Never use engine or carburetor cleaners in the fuel tank or permanent damage may occur.

OPERATION

Read the **Safety Instructions** section and the following pages if you are unfamiliar with the machine.

Training

Zero turn mowers are far more maneuverable than typical riding mowers due to their unique steering capabilities.

We suggest that this section be reviewed in its entirety prior to attempting to move the mower under its own power. Additionally, we suggest when first operating the mower, use a reduced throttle speed and reduced ground speed by NOT moving control levers to the furthest forward or reverse positions during initial operation, or until operator becomes comfortable with controls. We also suggest first time users, or new users to Zero Turn mowers to become familiar with the mower's movement on a hard surface, such as concrete or blacktop PRIOR to attempting to operate on turf. Until operator becomes comfortable with mower controls and zero turning capability, they may damage turf due to overly aggressive maneuvers.

Steering

To move forward and backward

The direction and speed of the mower's movements is effected by the movement of the control lever(s) on each side of mower. The left control lever controls the left wheel. The right control lever controls the right wheel.

IMPORTANT INFORMATION

When control levers are in the reverse position they return to neutral when released. This may cause the mower to suddenly stop.

First time users should push mower (see *Manual Transport* in the **Operation** section) to an open, flat area, without other people or vehicles or obstacles nearby. To move unit under its own power, the operator must be in the seat, start engine (see *Before Starting* in the **Operation** section), adjust engine speed to idle, disengage parking brake, do not engage blades at this time, rotate control levers inward. As long as the control levers have not been

moved forward or backwards, the mower will not move. Slowly move both control levers forward slightly. This will allow mower to start moving forward in a straight line. Pull back on control levers to the neutral position and mower should stop moving. Pull back slightly on control levers, this will allow mower to start moving backwards. Push forward on control levers to the neutral position and mower should stop moving.

To turn to the right

While moving in a forward direction, pull the right lever back towards the neutral position while maintaining the position of the left lever, this will slow the rotation of the right wheel and cause the machine to turn in that direction.

To turn to the left

While moving in a forward direction pull the left lever back towards the neutral position while maintaining the position of the right lever, this will slow the rotation of the left wheel and cause the machine to turn in that direction.

To zero turn

While moving in a forward direction, first pull both control levers back until the mower stops or slows dramatically.

Then by alternating one lever slightly to the forward position and the other in the reverse position, the mower turns to the direction of the reverse position lever.

OPERATION

Before Starting

- Read the sections Safety Instructions and Controls before starting the machine.
- Perform the daily maintenance before starting (see maintenance schedule in the Maintenance section)
- Check that there is sufficient fuel in the fuel tank.
- Adjust the seat to the desired position.

The following conditions must be fulfilled before the engine can be started:

1. The blade switch for engaging the mower blades must be depressed.
2. The parking brake must be on.
3. Both steering controls must be in the locked (outer) neutral position

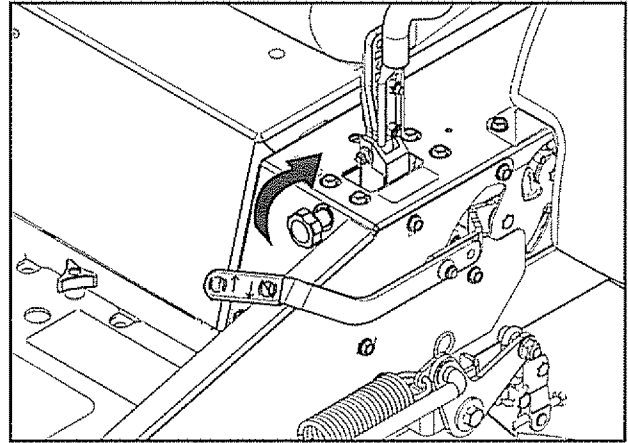

E05E-044

Activate parking brake before starting

Starting the Engine

1. Sit on the seat
2. Raise the mower deck to the transport position by locking the lift pedal fully forward.
3. Activate the parking brake

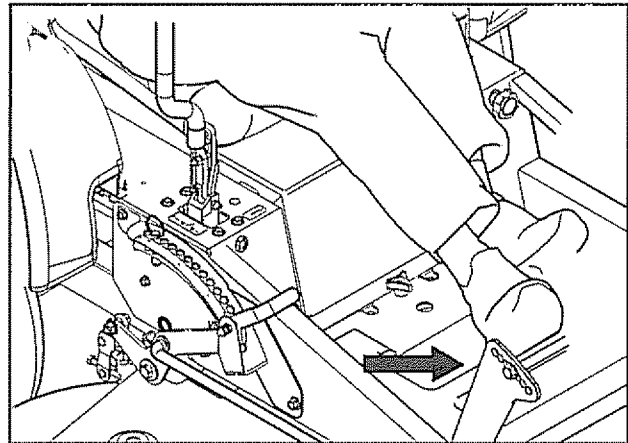

E05E-048

Set mower deck to the transport position

OPERATION

- 4 Disengage the mower blades by depressing the blade switch

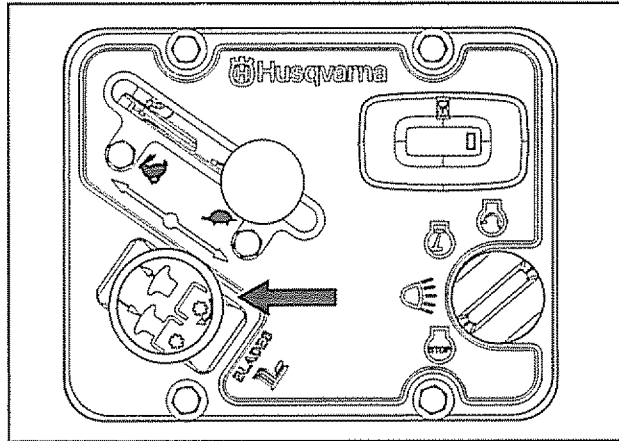

8056-043

Press the control for disengaging the mower deck

- 5 Move the steering controls outward to the locked (outer) neutral position.

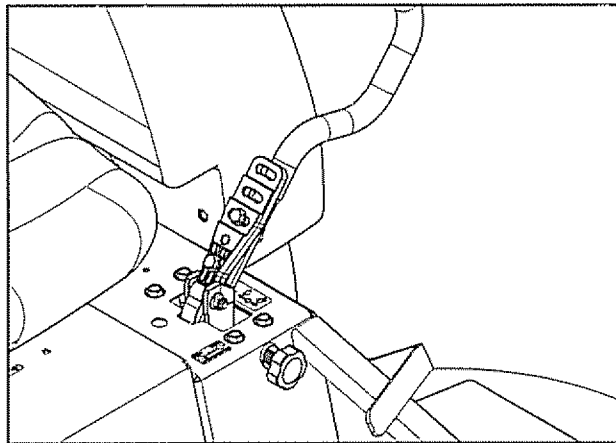

80661-012

Place controls in neutral position

- 6 Move the throttle to the middle position

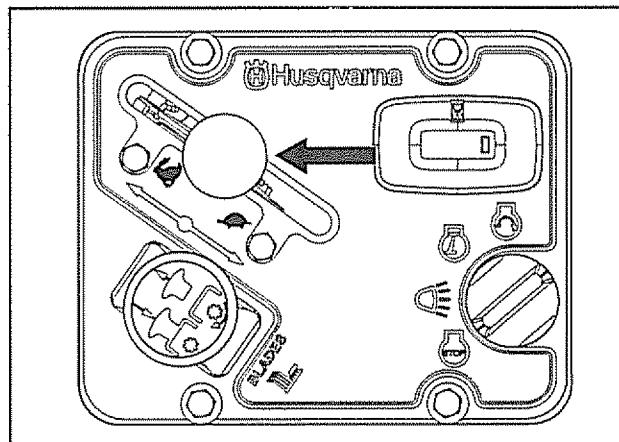

80656-050

Set the throttle

OPERATION

7. Open the fuel tank valve.



WARNING!

Engine exhaust and certain vehicle components contain or emit chemicals considered to cause cancer, birth defects or other reproductive system damage. The engine exhaust contains carbon monoxide, which is an odorless, colorless, poisonous gas. Do not use the machine in enclosed spaces.

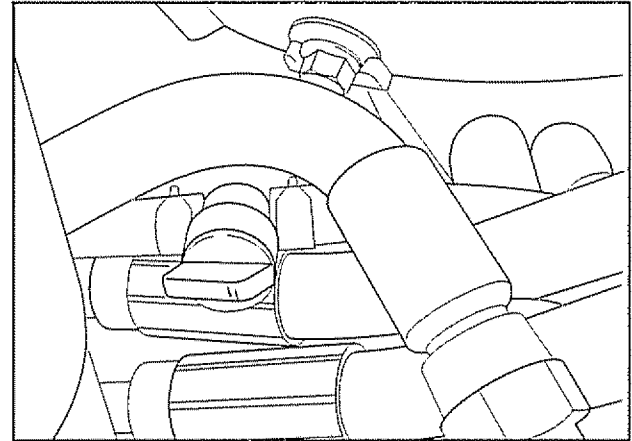

8065-013

Fuel valve in the OPEN position

8. Press in and turn the ignition key to the start position.

IMPORTANT INFORMATION

Do not run the starter for more than 5 seconds each time. If the engine does not start, wait about 10 seconds before retrying.

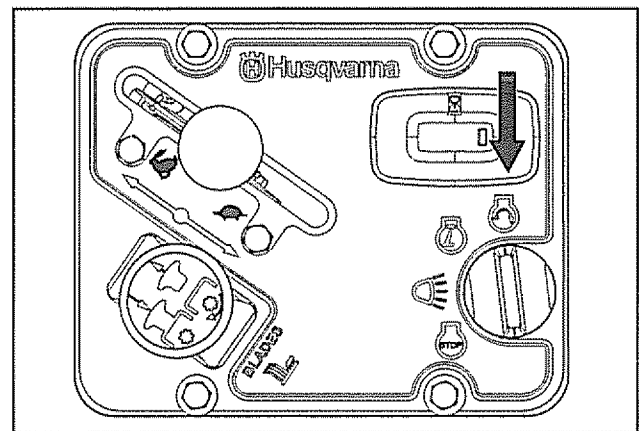

80658-050

Turn to the START position

IMPORTANT INFORMATION

The Briggs & Stratton engine on this unit is equipped with Electronic Fuel Management (EFM). The engine choke is automatically regulated during starting and warm up.

9. When the engine starts, immediately release the ignition key back to the run position.
10. Set the desired engine speed with the throttle. Allow the engine to run at a moderate speed, "half throttle", for 3-5 minutes before loading it too heavily. USE FULL THROTTLE WHEN MOWING.

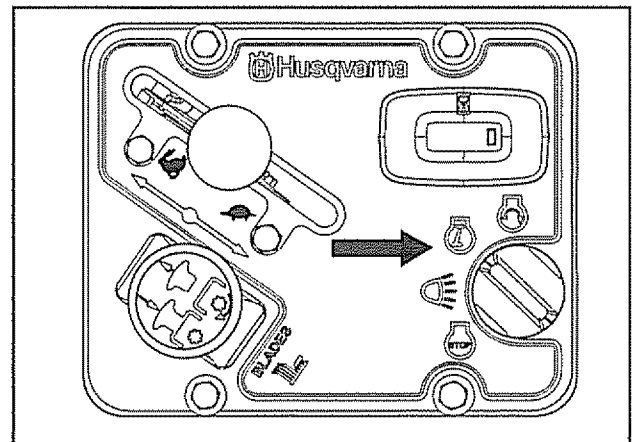

8066-038

Release ignition to the RUN position

OPERATION

Weak Battery

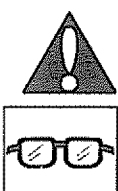
 **WARNING!**
Lead-acid batteries generate explosive gases. Keep sparks, flame and smoking materials away from batteries. Always wear eye protection when around batteries.

IMPORTANT INFORMATION

The mower is equipped with a 12-volt negative grounded system. The other vehicle must also be a 12-volt negative grounded system. Do not use the mower to start other vehicles.

IMPORTANT INFORMATION

Refer to the EFM Information Sheet from the unit literature packet for specific jump starting instructions.

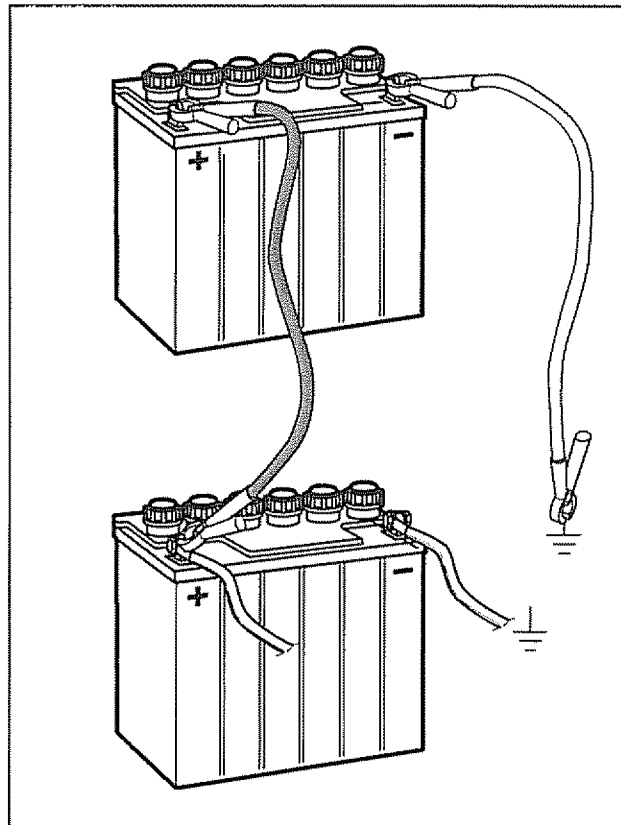

Jumper cable connection

8011-642

If "jumper cables" are used for emergency starting, follow this procedure:

Jumper Cables

- Connect each end of the RED cable to the POSITIVE (+) terminal on each battery, taking care not to short against chassis.
- Connect one end of the BLACK cable to the NEGATIVE (-) terminal of the fully charged battery.
- Connect the other end of the BLACK cable to a good CHASSIS GROUND on the mower with the discharged battery, away from the fuel tank and battery.

To remove cables, reverse order

- Remove BLACK cable first from chassis and then from the fully charged battery.
- Remove RED cable last from both batteries.

OPERATION

Running

1. Release the parking brake by moving the lever downward
NOTE: The mower is equipped with an operator presence system. When the engine is running, any attempt by the operator to leave the seat without first setting the parking brake will shut off the engine.
2. Move the steering controls to the neutral position (N)

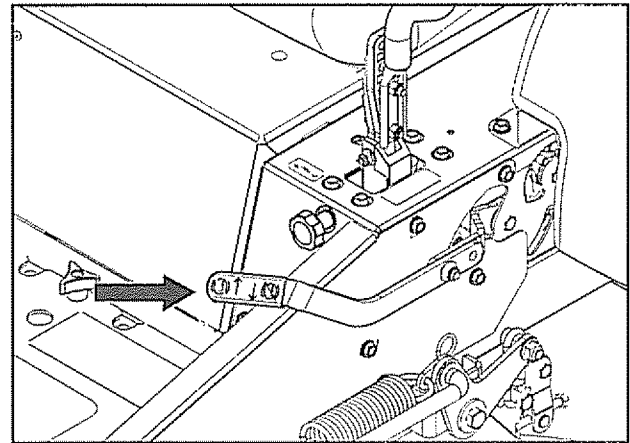

8058-044

Parking brake

3. Select the cutting height by setting the cutting height pin into the desired hole. Release foot pedal latch and lower deck to set cutting height.
4. Make sure the work area is free from objects that could be thrown by the rotating blades.

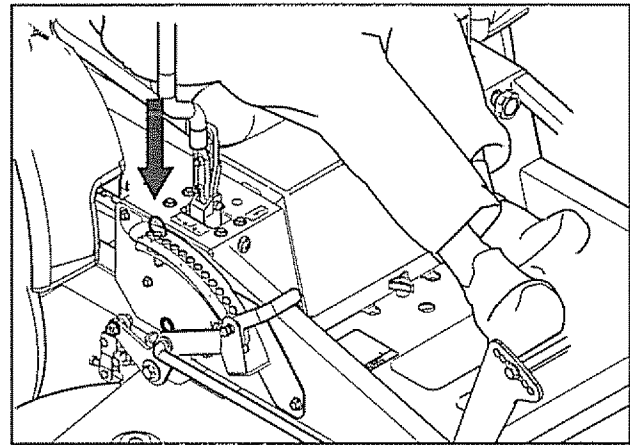

8065-017

Cutting height selection



WARNING!

Ensure that no one is near mower when engaging blade switch.

5. Engage the mower deck by pulling out the blade switch.
6. Move throttle control to full throttle (rabbit symbol).
7. The machine's speed and direction are continuously variable using the two steering controls. When both controls are in the neutral position, the machine stands still. By moving both controls an equal amount forward or backward, the machine moves in a straight line forward or backward respectively.

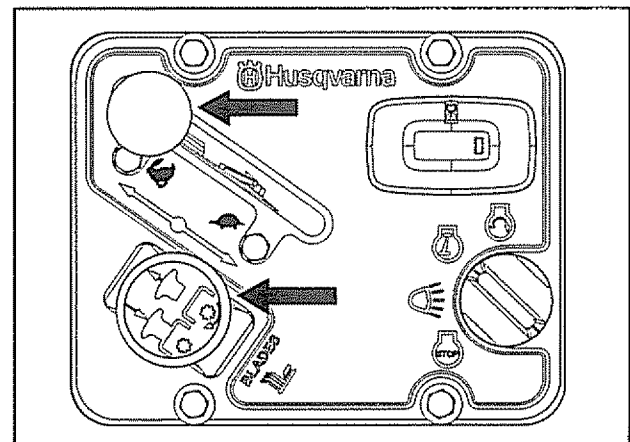

8065-016

Engage the mower deck and move the throttle to FULL

OPERATION

Operating on Hills

Read the Safety Instructions *Driving on Slopes* in the *Safety Instructions*.



WARNING!

Do not drive up or down hills with slopes greater than 10 degrees. Do not drive across slopes.

IMPORTANT INFORMATION

Control levers return to neutral when released. This may cause the mower to suddenly stop.

- The slowest speed possible should be used before starting up or down hills.
- Avoid stopping or changing speed on hills.
- If stopping is absolutely necessary, pull drive levers into the neutral position and push to the outside of the unit and engage the parking brake.

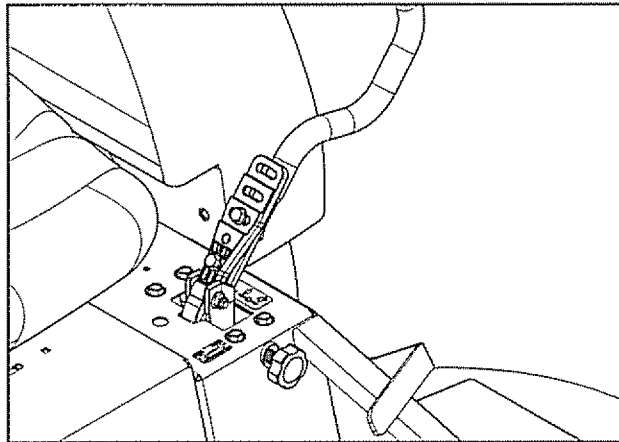

80561-012

Place controls in neutral position

- To restart movement, release the parking brake.
- Pull the control levers back to the center of the mower and press forward to regain forward motion.
- Make all turns slowly.

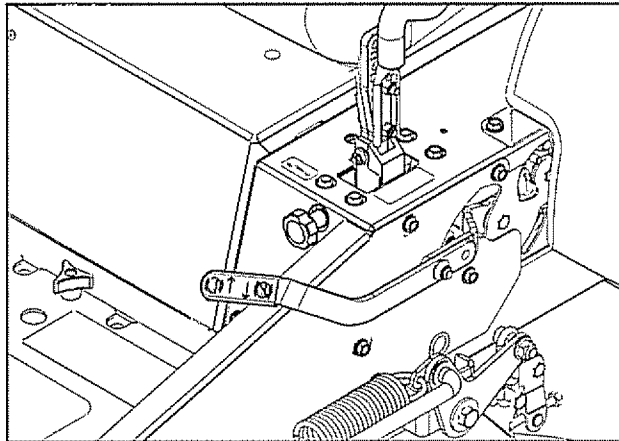

8055-044

Release the parking brake to restart movement

OPERATION

Stopping the Engine

Move the throttle to the minimum position (tortoise symbol). If the engine has been worked hard, allow it to idle at least 60 seconds to attain a normal operating temperature before stopping. To prevent fouling the spark plugs, avoid idling the engine for longer periods.

1. Disengage the mower deck by depressing the blade switch

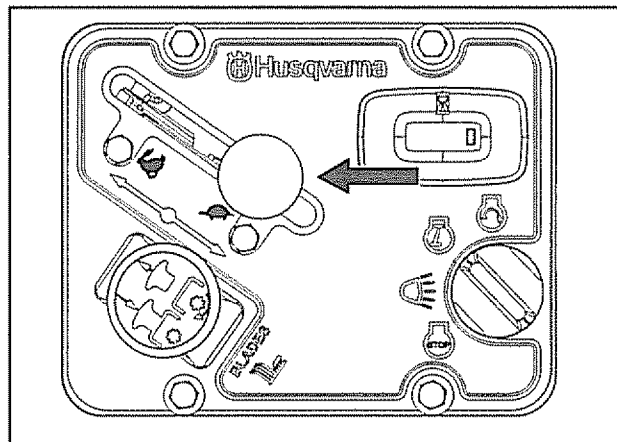

8058-046

Disengage the mower deck and move throttle to minimum

2. Raise the mower deck by pressing the foot pedal forward to the transport position.
3. When the machine is standing still, activate the parking brake by pulling the lever upward.
4. Move the throttle to the minimum position (tortoise symbol) Turn the ignition key to the stop position.

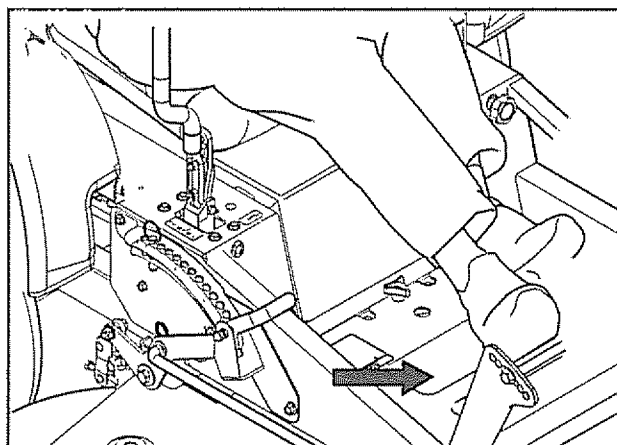

8058-048

Raise deck to transport position

5. Move the steering controls outward
6. Remove key. To prevent unauthorized use, always remove key when leaving the mower.

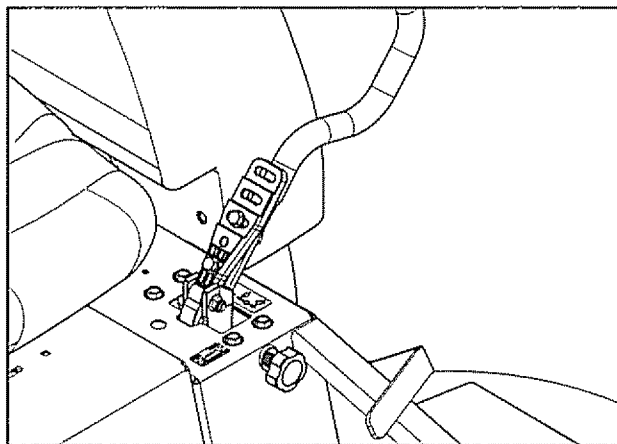

8061-012

Place controls in neutral position to stop

OPERATION

Mowing Tips

- Observe and flag rocks and other fixed objects to avoid collisions
- Begin with a high cutting height and reduce it until the desired mowing result is attained. The average lawn should be cut to 2½" (64 mm) during the cool season and over 3" (76 mm) during the hot months. For healthier and better looking lawns, mow often after moderate growth
- For best cutting performance, grass over 6" (15 cm) in height should be mowed twice. Make the first cut relatively high; the second to the desired height.
- The mowing result will be best with a high engine speed (the blades rotate rapidly) and low speed (the rider moves slowly). If the grass is not too long and dense, the driving speed can be increased without negatively affecting the mowing result.
- The finest lawns are obtained by mowing often. The lawn becomes more even and the grass clippings more evenly distributed over the mown area. The total time taken is not increased as a higher operating speed can be used without poor mowing results.
- Avoid mowing wet lawns. The mowing result is poorer because the wheels sink into the soft lawn, clumps build, and the grass clippings fasten under the cowl.
- Hose the mower deck underside with water after each use. When cleaning, the mower deck shall be raised into the transport position. Make sure the mower is cooled and the engine is off.
- Use compressed air to clean top surface of the deck. Avoid flooding water on top surface, engine and electrical components.
- When the mulching kit is used, it is important that the mowing interval is frequent and that the deck is cleaned more often.



WARNING!

Clear the lawn of stones and other objects that can be thrown out by the blades.

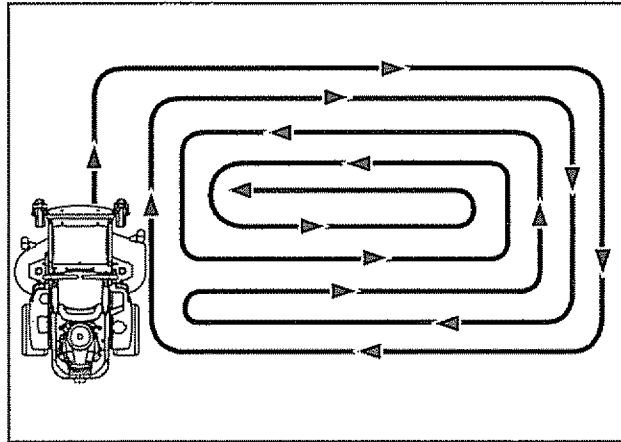

Mowing pattern

8011-603b



WARNING!

Never drive the rider on terrain that slopes more than 10 degrees. Mow slopes up and down, never side to side. Avoid sudden directional changes.

OPERATION

Manual Transport



WARNING!

No adjustments or maintenance should be carried out unless:

- the engine stopped
- the ignition key removed
- the parking brake activated

When pushing or pulling the mower, engage the IZT (Integrated Zereturn Transaxle) bypass linkages. The linkages are located on each side of the rear of the unit below the rear engine plate.

Raise the deck to the highest (transport) position. Pull the bypass linkages up and out of the keyhole slots. Release the lever with the head outside the bracket and held into the bypass setting.

To reengage the IZTs to drive, reverse the above procedure.

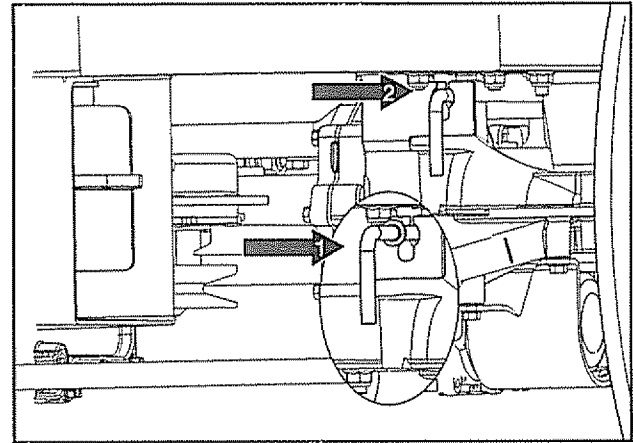

#065-061

- 1 IZT locked into the bypass position
 - 2 Linkage lever, engaged
- Right side, IZT linkage*

MAINTENANCE

MAINTENANCE	Daily		At least once each year	Maintenance interval in hours		
	Before	After		50	250	500
Check the parking brake	●					
Check the engine's oil level (every refueling)	■					
Check the safety system	●					
Check for fuel and oil leakages	◆					
Check/clean the engine's cooling air intake		■				
Check the mower deck		●				
Check for loose hardware (screws, nuts)		●				
Clean under the mower deck		●		●	●	●
Start the engine and blades, listen for unusual sounds		◆				
Check for damage		◆		◆	◆	◆
Thoroughly clean around the engine		◆		◆	◆	◆
Clean around belts, belt pulleys		◆		◆	◆	◆
Check the tire pressures		●		●	●	●
Check battery connections			●	●	●	●
Sharpen ³⁾ / Replace mower blades			●	●	●	●
Clean the engine's cooling air intake ²⁾			■	■	■	■
Clean the air cleaner's pre-filter ²⁾ (foam)			■		■	
Clean the air cleaner's filter cartridge ²⁾ (paper filter)			■		■	
Check/adjust the parking brake			●	●	●	●
Inspect muffler/spark arrestor			◆	◆	◆	◆

¹⁾ First change after 8-10 hours. When operating with a heavy load or at high ambient temperatures, replace every 50 hours. ²⁾ In dusty conditions, cleaning and replacement are required more often. ³⁾ Performed by authorized service workshop

● = Described in this manual

◆ = Not described in this manual

■ = Refer to the engine manufacturer's manual

MAINTENANCE

MAINTENANCE	Daily		At least once each year	Maintenance interval in hours		
	Before	After		50	250	500
Check/adjust throttle cable					■	
Check the condition of belts, belt pulleys			●		●	
Change the engine oil ¹⁾			■	■		
Replace the engine oil filter			■		■	
Clean/replace the spark plugs			■		■	
Replace the fuel filter			●		●	
Replace air filter ²⁾ (paper filter)			■		■	
Check the caster wheels (every 200 hours)			●		●	
Replace the air cleaner's pre-filter ²⁾ (foam)			■			
Check the hydraulic oil in the oil tank		●				
Change the hydraulic oil (every 500 hours)			●			●
Replace the hydraulic oil filter (every 500 hours)			●			●
Dismantle and inspect starter ³⁾ (every 500 hours)						◆
Check/adjust the mower deck			●			●
Check the engine valve clearance ³⁾			◆			◆
Perform the 500-hour service ³⁾			◆			◆

¹⁾ First change after 5-8 hours. When operating with a heavy load or at high ambient temperatures, replace every 50 hours. ²⁾ In dusty conditions, cleaning and replacement are required more often. ³⁾ Performed by authorized service workshop.

● = Described in this manual

◆ = Not described in this manual

■ = Refer to the engine manufacturer's manual



WARNING!

Before performing any service or adjustment checklist:

- Engage the parking brake.
- Place the Blade-switch in the disengaged position.
- Turn the ignition switch to "OFF" position and remove the key.
- Make sure the blades and all moving parts have completely stopped.
- Disconnect the spark plug wire from all spark plugs and place the wire where it cannot come in contact with the plug.

MAINTENANCE

Battery

Your mower is equipped with a maintenance free battery and does not need servicing. However, periodic charging of the battery with an automotive type battery charger will extend its life.

- Keep battery and terminals clean
- Keep battery bolts tight
- See chart for charging times.

STANDARD BATTERY	STATE OF CHARGE	APPROXIMATE BATTERY CHARGING TIME* TO FULL CHARGE AT 80°F / 27°C			
		Maximum Rate at:			
		50 Amps	30 Amps	20 Amps	10 Amps
12.6V	100%	- FULL CHARGE -			
12.4V	75%	20 min.	35 min.	48 min.	90 min.
12.2V	50%	45 min.	75 min.	95 min.	180 min.
12.0V	25%	65 min.	115 min.	145 min.	260 min.
11.8V	0%	85 min.	150 min.	195 min.	370 min.

*Charging time depends on battery capacity, condition, age, temperature and efficiency of charger.



WARNING!

Always wear eye protection when around batteries.

Cleaning battery and terminals

Corrosion and dirt on the battery and terminals can cause the battery to "leak" power.

1. Open the terminal access doors
2. Disconnect BLACK battery cable first, then the RED battery cable and remove the battery from the machine.
3. Rinse the battery with plain water and dry.
4. Clean terminals and battery cable ends with wire brush until shiny.
5. Coat terminals with grease or petroleum jelly
6. Reinstall battery.

Replacing battery

1. Lift seat and rotate forward.
2. Open terminal access doors
3. Using two 1/2" wrenches disconnect BLACK battery cable then RED battery cable.
4. Using a 7/16" wrench, remove the bolts on either side of the terminal guard and lift off guard.
5. Carefully remove the battery from the mower.
6. Install new battery with terminals in the same position as the old battery.
7. Reinstall battery terminal guard.
8. First connect RED battery cable to positive (+) battery terminal with hex bolt and hex nut.
9. Connect BLACK grounding cable to negative (-) battery terminal with remaining hex bolt and hex nut.
10. Close access doors.
11. Lower seat.

IMPORTANT INFORMATION

Do not attempt to open or remove caps or covers. Adding or checking level of electrolyte is not necessary.

Always use two wrenches for the terminal screws.



WARNING!

Do not short battery terminals by allowing a wrench or any other object to contact both terminals at the same time. Before connecting battery, remove metal bracelets, wristwatch bands, rings, etc.

Positive terminal must be connected first to prevent sparks from accidental grounding.

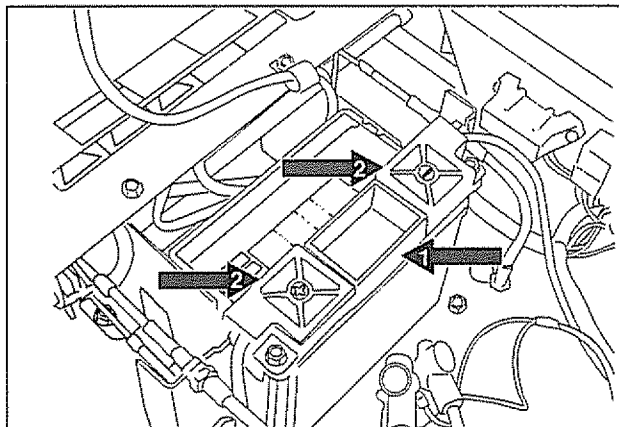

CZ-22

1. Terminal guard
 2. Access doors
- Battery cleaning and installation

MAINTENANCE

Safety System

This machine is equipped with a safety system that prevents starting or driving under the following conditions

The engine can only be started when:

1. The mower deck is disengaged
2. The steering controls are in the outer, locked neutral position
3. The parking brake is on.

Make daily inspections to ensure that the safety system works by attempting to start the engine when one of the conditions is not met. Change the conditions and try again.

If the machine starts when one of these conditions is not met, turn the machine off and repair the safety system before using the machine again.

Make sure the engine stops when the park brake is not engaged and the operator leaves the seated position.

Check that the engine stops if the mower blades are engaged and the driver temporarily moves off the driver's seat.

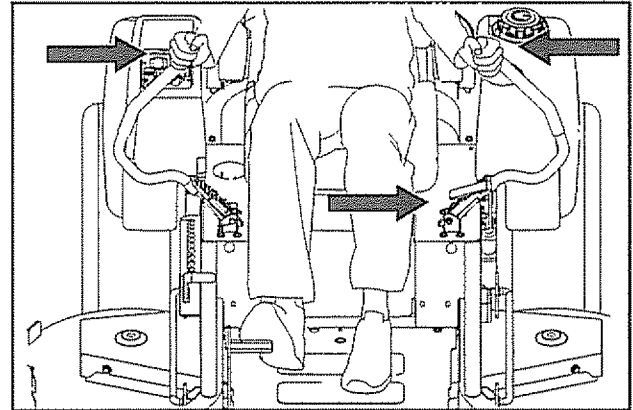

8061-032

Conditions for starting

IMPORTANT INFORMATION

To be able to drive, the driver must sit in the seat and release the parking brake before the steering controls can be moved into the neutral position, otherwise the engine will stop.

Tire Pressures

Fill tire pressures to 15 psi / 103 kPa / 1 bar

IMPORTANT INFORMATION

DO NOT add any type of tire liner or foam fill material to the drive tires. Excessive loads created by foam filled tires will cause premature failures.
Only use O.E.M. specified tires.

Parking Brake

Visually check that no damage is found on the lever, links, or switch belonging to the parking brake. Perform a standstill test and check that there is sufficient braking action.



WARNING!

Faulty adjustment results in reduced braking ability and can cause an accident.

IMPORTANT INFORMATION

The machine must be standing still when applying the parking brake.

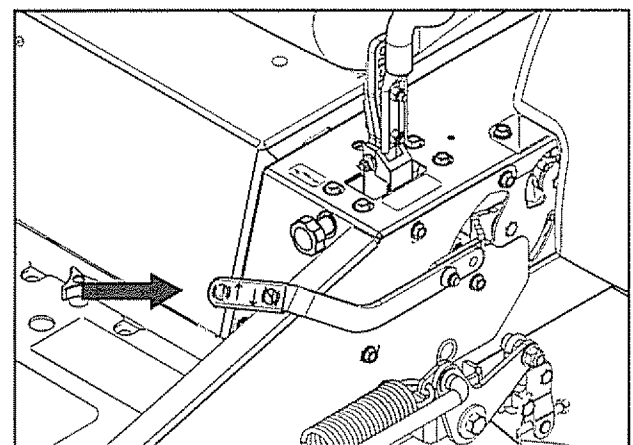

8058-044

Parking brake

MAINTENANCE

Deck Belt

Deck Belt Removal

Park on a level surface. Apply park brake. Lower the deck into the lowest cutting position.

1. Remove foot plate and belt shields.
2. Using a ratchet or breaker bar with a $\frac{9}{16}$ " socket on the spring idler bolt, relieve the tension on the belt.
3. Remove any dirt or grass that may have accumulated around the cutter housings and entire deck surface.
4. Carefully roll the belt over the top of the cutter housing pulleys.
5. Remove the belt from around the electric clutch on the engine shaft and off the mower deck.

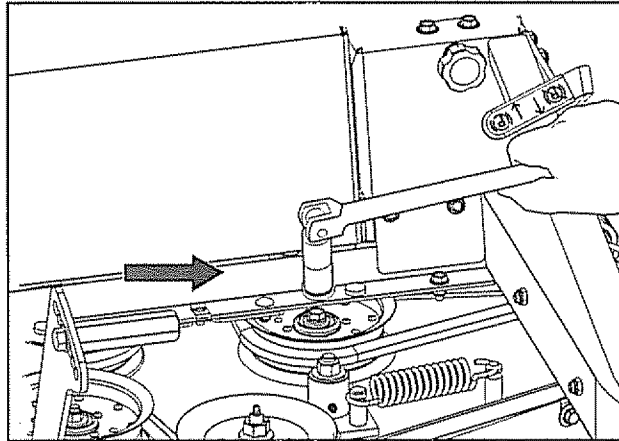

Slackening the belt tensioner

8058-063

Deck Belt Installation

NOTE: For ease in installing the deck belt, refer to the routing decal on the deck.

1. Wrap the deck belt around the electric clutch pulley that is located on the engine shaft.
2. Route the belt forward between the spring loaded and stationary pulleys.
3. Place belt around spring loaded idler pulley
4. Wrap the belt around the stationary idler pulley and around the mandrel housings.
5. Push inward on the idler arm and carefully route belt over stationary idler pulley. Once belt is properly routed, slowly release idler arm to tension belt.
6. Check that there are not twists in the belt and that the routing matches the routing decal.
7. Replace belt shields on both mandrel housings and secure with fasteners.

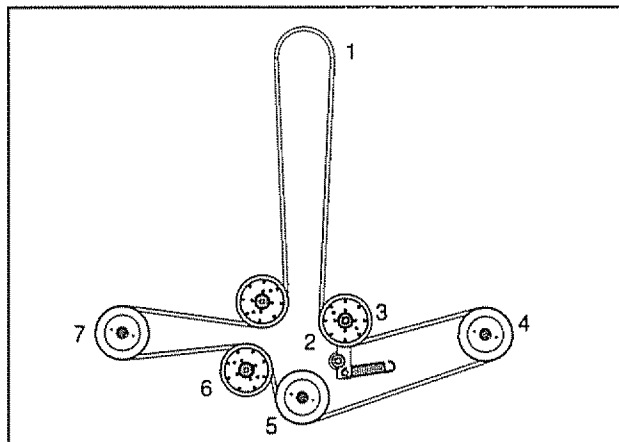

Belt routing, deck belt

8058-061

MAINTENANCE

Pump Belt

The belts are not adjustable. Replace belts if they begin to slip from wear.

Replacing Pump Belt

Park the mower on a level surface. Engage the parking brake.

Belt Removal

From the top side of the deck:

1. Remove the deck belt (see *Deck Belt Removal* in this section of the manual).
2. Tilt seat forward to access fan covers. Remove both fan covers.

From the underside of the mower:

3. Remove clutch stop to access the belt.
4. With a $\frac{1}{2}$ " breaker bar and using the square opening in the pump idler arm, shift the arm to create slack in the belt.
5. With the idler arm in the slack position, slip a screwdriver, clevis pin or similar into the $\frac{3}{8}$ " hole in the plate that sits between the two fan covers. This will keep the idler in the extended position and allow removal of the breaker bar.
6. Remove belt from the engine and pump pulleys over the top of the fans.

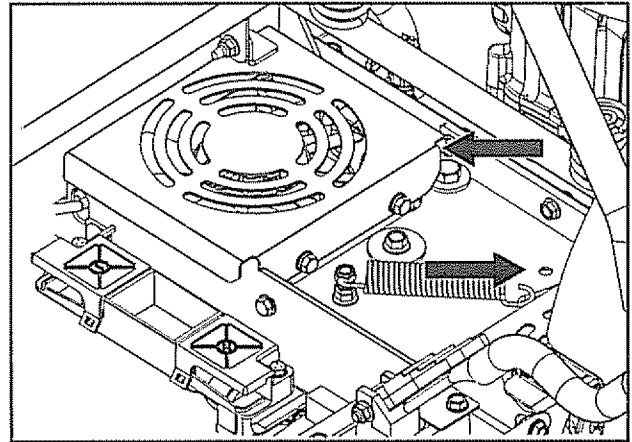

8056-C64

Remove fan covers

Belt Installation

1. If the pump is not locked in the extended position, repeat Steps 4 and 5 from the above instructions.
2. Slip the belt over the fans and route it between the idler pulleys.
3. Place the belt over the right and left idler pulleys.
4. Place the belt on the engine pulley.
5. Use the breaker bar to hold the tension off the belt while removing the implement used as a brace in the plate.
6. Replace and secure clutch stop.
7. Reinstall the fan shields.
8. Reinstall the deck belt. (See *Deck Belt Installation* in this section of the manual).

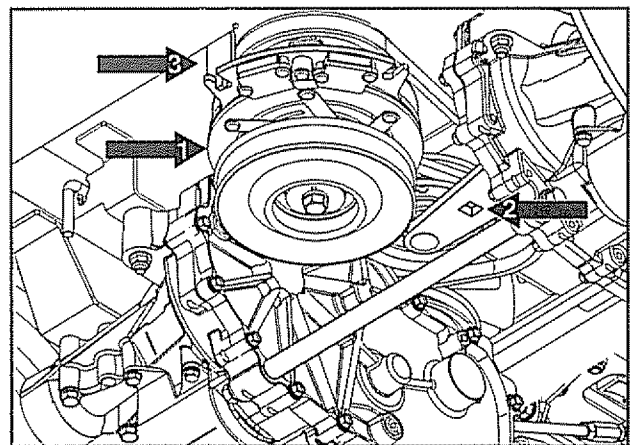

8056-C60

1. Electric clutch
 2. Idler arm release placement
 3. Clutch stop
- Pump belt removal*

V-belts

Check every 100 hours of operation. Check for severe cracking and large nicks.

NOTE: The belt will show some small cracks in normal operation.

MAINTENANCE

Cutting Blades

To attain the best mowing effect, it is important that the blades are well sharpened and not damaged.

Bent or cracked blades or blades with large nicks should be replaced.

Blades damaged from hitting obstacles that result in a breakdown should be replaced. The service workshop should decide whether the blade can be repaired/ground or must be replaced. Balance the blades after sharpening.

Check the blade mounts.

Blade Replacement

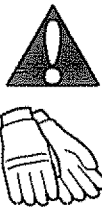

WARNING!

Blades are sharp. Protect your hands with gloves and/or wrap blades with a heavy cloth when handling.

1. Remove blade bolt by turning counterclockwise.
2. Install new or re-sharpened blade with stamped "GRASS SIDE" facing towards ground/grass (down) or "THIS SIDE UP" facing deck and cutter housing.
3. Install and tighten blade bolt securely.
4. Torque blade bolt to 45-55 ft-lbs (60-75 Nm).

IMPORTANT INFORMATION

Special blade bolt is heat treated.

Replace with a Husqvarna bolt if required.

Do not use lower grade hardware than specified.



WARNING!

Blades are sharp. Protect your hands with gloves and/or wrap blades with a heavy cloth when handling.



IMPORTANT INFORMATION

The sharpening of blades should be carried out by an authorized service workshop.

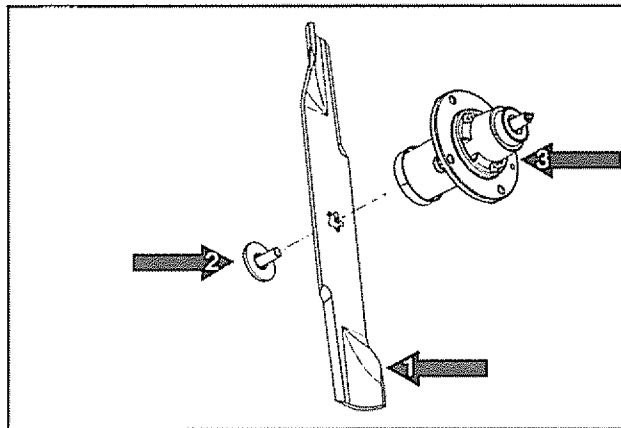

- 1 Blade
 - 2 Blade bolt (special)
 - 3 Cutter housing
- Blade attachment



WARNING!

Before performing any service or adjustment checklist:

1. Engage the parking brake.
2. Place the Blade switch in the disengaged position.
3. Turn ignition switch to "OFF" position and remove the key.
4. Make sure the blades and all moving parts have completely stopped.
5. Disconnect the spark plug wire from all spark plugs and place the wire where it cannot come in contact with the plug.

MAINTENANCE

Adjusting the Mower Deck

Check the tire pressure before adjustment of the mower deck. See *Tire Pressures* in *Maintenance* section. Faulty mower deck adjustments will cause an uneven mowing result.

Leveling deck

Adjust the deck while the mower is on a level surface. Make sure the tires are inflated to the correct pressure. See *Technical Data / Transmission*. If tires are under or over inflated, you cannot properly adjust your deck.

Four slots control the height and pitch of the mower deck. The deck should be adjusted slightly higher in the rear.

NOTE: To insure accuracy of leveling procedure, mower deck drive belt must be installed prior to leveling deck.

1. Wear heavy gloves. Turn each outer blade tip to align with the deck or in a side-to-side manner.
2. Measure from the floor surface up to the bottom of the blade tip on the discharge side of the mower deck. Retain this measurement. Move to the opposite side, check that measurement is the same. If adjustment is required, loosen the locknut and move mounting bolt up or down in slot until both side-to-side measurements are equal. Retain measurement.
3. Turn both outer blades to align with the deck in front-to-rear manner. Reposition rear mounting bolts up or down until rear of mower deck is positioned level to $\frac{1}{8}''$ higher in the rear than the side-to-side measurement.
4. Confirm measurements once again. Blade tips should be level in a side-to-side manner. In the rear, blade tips should be level to $\frac{1}{8}''$ higher than side-to-side measurement. In the front, blade tips should be level to $\frac{1}{8}''$ lower than side-to-side measurement.

NOTE: This will place the mower deck in a base measurement position. Additional adjustment may be required to achieve desired cut for the type of grass or conditions being mowed.

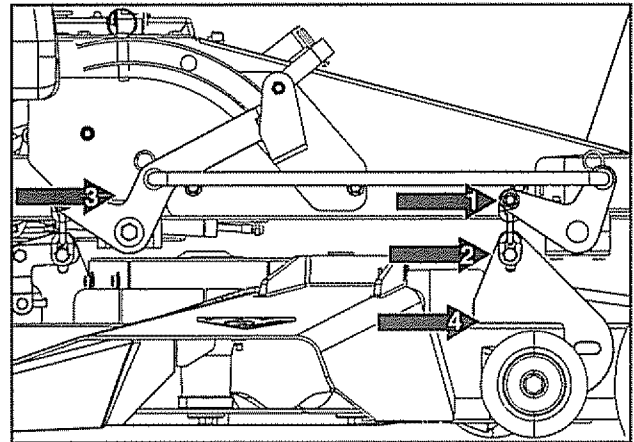
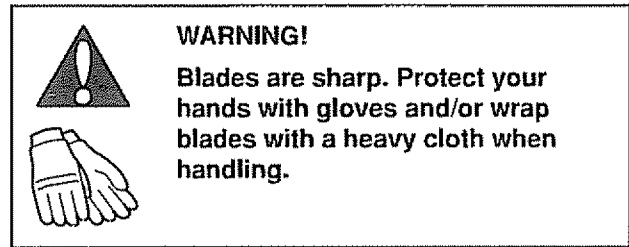

E011-EQ1-3

1. Front lift arm
 2. Chain
 3. Rear lift arm
 4. Slotted deck hanger plates
- Leveling the mower deck*

MAINTENANCE

Anti-scalp rollers

Anti-scalp rollers are properly adjusted when they are just slightly off of the ground when the deck is at the desired cutting height in the operating position. Anti-scalp rollers then keep the deck in the proper position to help prevent scalping in most terrain conditions.

IMPORTANT INFORMATION

Adjust anti-scalp rollers with the mower on a flat level surface.

The **anti-scalp rollers** can be set in three positions:

- Upper position 1½" to 3" (38 to 76 mm) grass.
- Middle position 3" to 4½" (76 to 114 mm) grass.
- Lower position 4½" to 6" (114 to 152 mm) grass.

The rollers should be approximately ¼" (6.5 mm) from ground. Do not adjust the rollers to support the deck.

IMPORTANT INFORMATION

The anti-scalp rollers must not be used for gauge wheels or the roller and deck may be damaged.

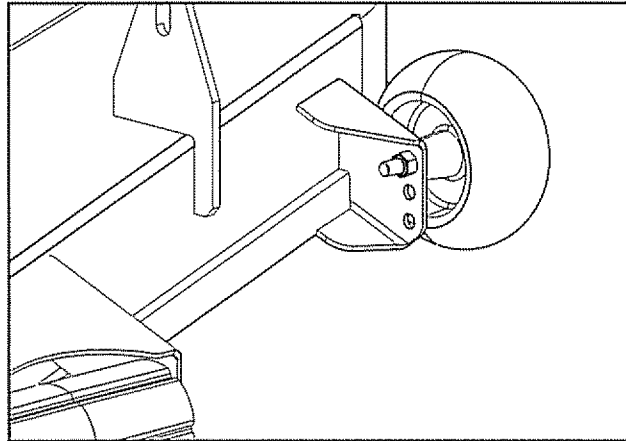

Anti-scalp rollers

805B-05A

MAINTENANCE

Caster Wheels

Check every 200 hours. Check that wheels rotate freely.

IMPORTANT INFORMATION

DO NOT add any type of tire liner or foam fill material to the tires. Excessive loads created by foam tires will cause premature failures.

Use only O.E.M. specified tires.

Removal and Installation

Remove nut and caster bolt. Pull the wheel out of the fork.

To reinstall, reverse the order. Tighten caster bolt.

If wheels do not rotate freely, take the unit to the dealer for service.

Hardware

Check daily. Inspect the entire machine for loose or missing hardware.

Cleaning

Regular cleaning and washing, especially under the mower deck, will increase the machine's life-span. Make it a habit to clean the machine directly after use (after it is cooled), before the dirt sticks.

Do not spray water on the top of the mower deck. Use compressed air to clean the top side of mower deck. Regularly clean deck and underside of the deck with normal water pressure. Do not use a high pressure washer or steam cleaner. Avoid spraying engine and electrical components with water.

Do not rinse hot surfaces with cold water. Let unit cool before washing.

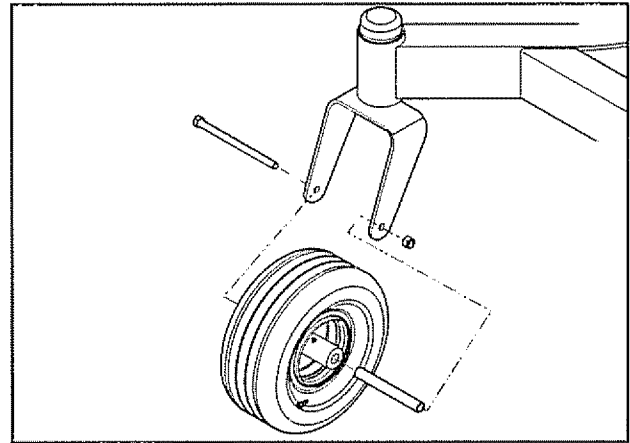

Caster wheel









8058-055







Use protective glasses when cleaning and washing.

LUBRICATION

Lubrication Schedule

12/12	1/52	1/365			25h	50h	100h	200h	300h
					1  (2x)				
					2  (2x)				
					3 				
				▲					
			▲	▲					
				*					

E056-056

12/12 Every year	Lubricate with grease gun 	Level check 
1/52 Every Week	Oil change 	
1/365 Every day	Filter change 	

* Change hydraulic drive filters.

▲ See Engine Manufacturer's manual

General

Remove the ignition key to prevent unintentional movements during lubrication.

When lubricating with an oil can, it must be filled with engine oil.

When lubricating with grease, unless otherwise stated, use high grade molybdenum disulphide grease.

For daily use, the machine should be lubricated twice weekly.

Wipe away excess grease after lubrication

It is important to avoid getting lubricant on the belts or the drive surfaces on the belt pulleys. Should this happen, attempt to clean them with spirits. If the belt continues to slip after cleaning, it must be replaced. Gasoline or other petroleum products must not be used to clean belts.

LUBRICATION

Wheel and Deck Zerks

Use only good quality bearing grease.

Grease from well-known brand names (petrochemical companies, etc) usually maintains a good quality

Front Wheel Mount

Lubricate with a grease gun until the grease is forced out.

Front Wheel Bearings

Lubricate 3-4 strokes with a grease gun on each set of wheel bearings.

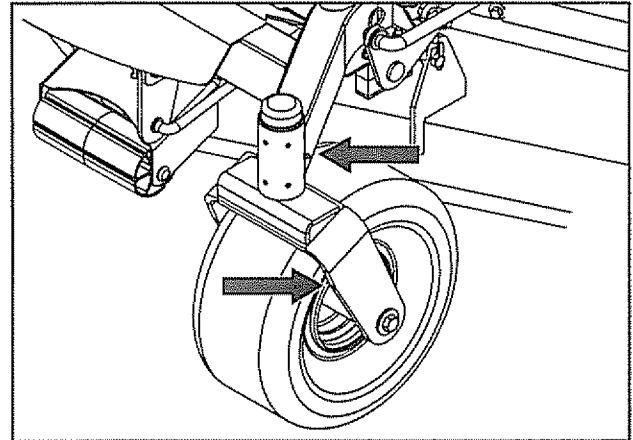

6056-057

Lubricating front wheels

Deck Spindles

Lower the cutting deck completely.

If a grease gun without rubber hose is used, the foot plate must be removed.

Lubricate with a grease gun, 2-3 strokes per spindle.

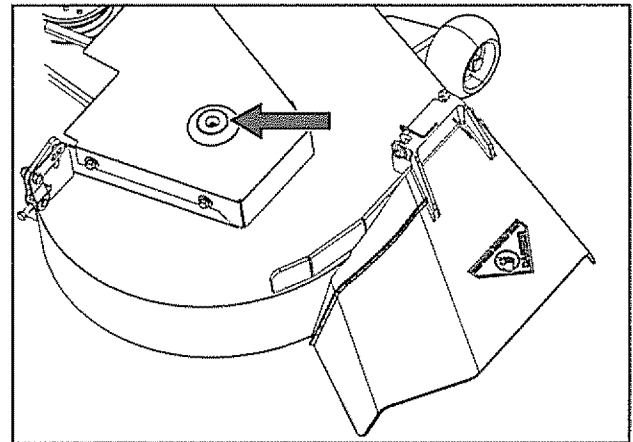

6056-056

Deck spindle

LUBRICATION

Transaxle (Transmission) Fluid Change

This transaxle is designed with an external filter for ease of maintenance. To ensure constant fluid quality levels and longer life, an oil filter change interval of every 200 hours is recommended.

The following procedure is performed with the transaxles installed in the mower and the mower on level ground. Apply the pump release valve for each transaxle and set the parking brake.

1. Remove the three ¼" filter guard screws and filter guard. Clean any loose debris from around the perimeter of the filter. See illustration
2. Place an oil drain pan (12" or more diameter and 8 qt. capacity is optimal) beneath the oil filter. Remove the oil filter from the transaxle

Drain old oil filters of all free-flowing oil prior to disposal. Place used oil in appropriate containers and dispose of it in accordance with laws in your area.

3. After the oil has drained, wipe the filter base surface and apply a film of new oil to the gasket of the replacement filter.
4. Install the new filter by hand, turning it three-quarters to one full turn after the filter gasket contacts the filter base surface.
5. Reinstall the filter guard. Torque screws to 65 in./lbs. each.
6. Repeat steps on the opposite side
7. Drain old oil filters of all free flowing oil prior to disposal. Place used oil in appropriate containers and dispose of it in accordance with laws in your area.
8. Remove the top port plug (see illustration) from the left side and right side of the transaxles prior to filling with oil. This will allow the transaxles to vent during oil fill.
9. Remove the cap from the transaxles' expansion tank located on the vehicle frame.

10. Fill with 20W50 motor oil until oil just appears at the bottom of each transaxles' top port (approximately 2 quarts per transaxle, 4 quarts total). Install the top port lug into each transaxle as the oil level reaches the port.
11. Install and torque the top port plugs to 180 in./lbs.
12. Continue to fill the transaxles through the expansion tank until the "Full Cold" line is reached (this will take approximately 23 additional ounces).
13. Reinstall the expansion tank cap by hand. Be careful to not overtighten
14. Proceed to the purge procedure.

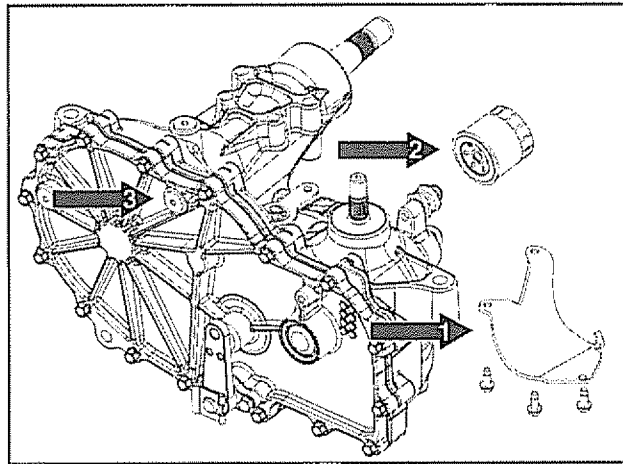

1. Filter guard
 2. Transaxle filter
 3. Top port plug
- ZT-3400 filter change

LUBRICATION

Purging Procedures

Due to the effects air has on efficiency in hydrostatic drive applications, it is critical to purge the system.

These purge procedures should be implemented any time a hydrostatic system has been opened to facilitate maintenance or any additional oil has been added to the system

Resulting symptoms in hydrostatic systems may be:

- Noisy operation.
- Lack of power or drive after short term operation
- High operation temperature and excessive expansion of oil
- Shortened component life.

Before starting, make sure the oil tank is at the proper oil level. If not, fill to the specifications outlined above.

The following procedures are best performed with the vehicle drive wheels off the ground, then repeated under normal operating conditions.

1. Disengage the brake if activated
2. With the bypass valve open and the engine running at fast idle, slowly move the directional control in both forward and reverse directions (5 or 6 times). As air is purged from the unit, the oil level will drop
3. With the bypass valve closed and the engine running, slowly move the directional control in both forward and reverse directions (5 to 6 times). Check the oil level and add oil as required after stopping the engine
4. It may be necessary to repeat Steps 2 and 3 until all the air is completely purged from the system. When the hydraulic drive operates at normal noise levels and moves smoothly forward and reverse at normal speeds, the hydraulic drive is considered purged.
5. After the vehicle has been used two times, the oil level should be checked while the oil is cold and adjusted accordingly.

TROUBLESHOOTING GUIDE

Problem	Cause
Engine will not start	<ul style="list-style-type: none">• Blade switch is engaged.• Steering controls are not locked in the neutral position.• Parking brake is not activated.• Battery is dead.• Contamination in the carburetor or fuel line.• Fuel supply is closed.• Clogged fuel filter or fuel line.• Faulty ignition system
Starter does not turn the engine over.	<ul style="list-style-type: none">• Dead battery.• Poor contacts on the battery terminal cable connections.• Fuse blown.• Ignition system faulty.• Fault in the starter safety circuit. See <i>Safety System</i> in the <i>Maintenance</i> section
Engine runs rough.	<ul style="list-style-type: none">• Faulty carburetor.• Clogged fuel filter or jet• Clogged ventilation valve on the fuel cap.• Fuel tank nearly empty.• Fouled spark plug.• Spark plug is loose• Rich fuel mixture or fuel-air mixture.• Wrong fuel type.• Water in the fuel.• Clogged air filter.
Engine seems weak.	<ul style="list-style-type: none">• Clogged air filter.• Fouled spark plugs.• Carburetor incorrectly adjusted.

TROUBLESHOOTING GUIDE

Problem	Cause
Machine vibrates.	<ul style="list-style-type: none">• Blades are loose.• Blades are incorrectly balanced.• Engine is loose.
Engine overheats.	<ul style="list-style-type: none">• Clogged air intake or cooling fins.• Engine overloaded.• Poor ventilation around engine.• Defective engine speed regulator.• Too little or no oil in the engine.• Fouled spark plug.
Battery not charging	<ul style="list-style-type: none">• Poor contact with battery terminal cable connectors.• Charging lead is disconnected.• Fault in engine charging system.
Machine moves slowly, unevenly, or not at all	<ul style="list-style-type: none">• Parking brake on.• Bypass valve on pump open.• Drive belt for the transmission gears slack or has come off.• Air in hydraulic system.
Mower deck not engaging	<ul style="list-style-type: none">• Drive belt for the mower deck has come loose.• Contact for the electromagnetic coupling has loosened• The blade switch is faulty or has come loose, from the cable contact.• The fuse has blown.
Hydraulic drive leaks oil.	<ul style="list-style-type: none">• Damaged seals, housing, or gaskets.• Air trapped in hydraulic system.
Uneven mowing results	<ul style="list-style-type: none">• Unequal tire pressure on the left and right sides.• Bent blades.• Suspension for the mower deck is uneven.• Blades are dull.• Driving speed too high.• The grass is too long.• Grass collected under the mower deck.

STORAGE

Winter Storage

At the end of the mowing season, the machine should be readied for storage (or if it will not be in use for longer than 30 days).

Fuel allowed to stand for long periods of time (30 days or more) can leave sticky residues that can plug the carburetor and disrupt engine function.

Fuel stabilizers are an acceptable option as regards to the sticky residues that can occur during storage.

Add stabilizer to the fuel in the tank or in the storage container. Always use the mixing ratios specified by the manufacturer of the stabilizer. Run the engine for at least 10 minutes after adding the stabilizer so that it reaches the carburetor. Do not empty the fuel tank and the carburetor if a stabilizer has been added.



WARNING!

Never store an engine with fuel in the tank indoors or in poorly ventilated spaces where fuel vapor can come in contact with open flames, sparks, or a pilot light such as in a boiler, hot water tank, clothes drier, etc. Handle the fuel with care. It is very flammable and can cause serious personal injury and property damage. Drain the fuel into an approved container outdoors and far away from open flame. Never use gasoline for cleaning. Use a degreaser and warm water.

To ready the machine for storage, follow these steps:

1. Thoroughly clean the machine, especially under the mower deck. Touch up damage to the paint and spray a thin layer of oil on the underside of the mower deck to avoid corrosion.
2. Inspect the machine for worn or damaged parts and tighten any nuts or screws that may have become loose.
3. Change the engine oil; dispose of properly.
4. Empty the fuel tanks or add a fuel stabilizer. Start the engine and allow it to run until the carburetor is drained of fuel or the stabilizer has reached the carburetor.
5. Remove the spark plug and pour about a tablespoon of engine oil into the cylinder. Turn over the engine so that the oil is evenly distributed and then refit the spark plug.
6. Lubricate all grease zerks, joints, and axles.
7. Remove the battery. Clean, charge, and store the battery in a cool place, but protect it from direct cold.
8. Store the machine in a clean, dry place and cover it for extra protection.

Service

When ordering spare parts, please specify the purchase year, model, type, and serial number.

Always use genuine Husqvarna spare parts.

An annual check-up at an authorized service workshop is a good way to ensure that the machine performs its best the following season.

WIRING DIAGRAM

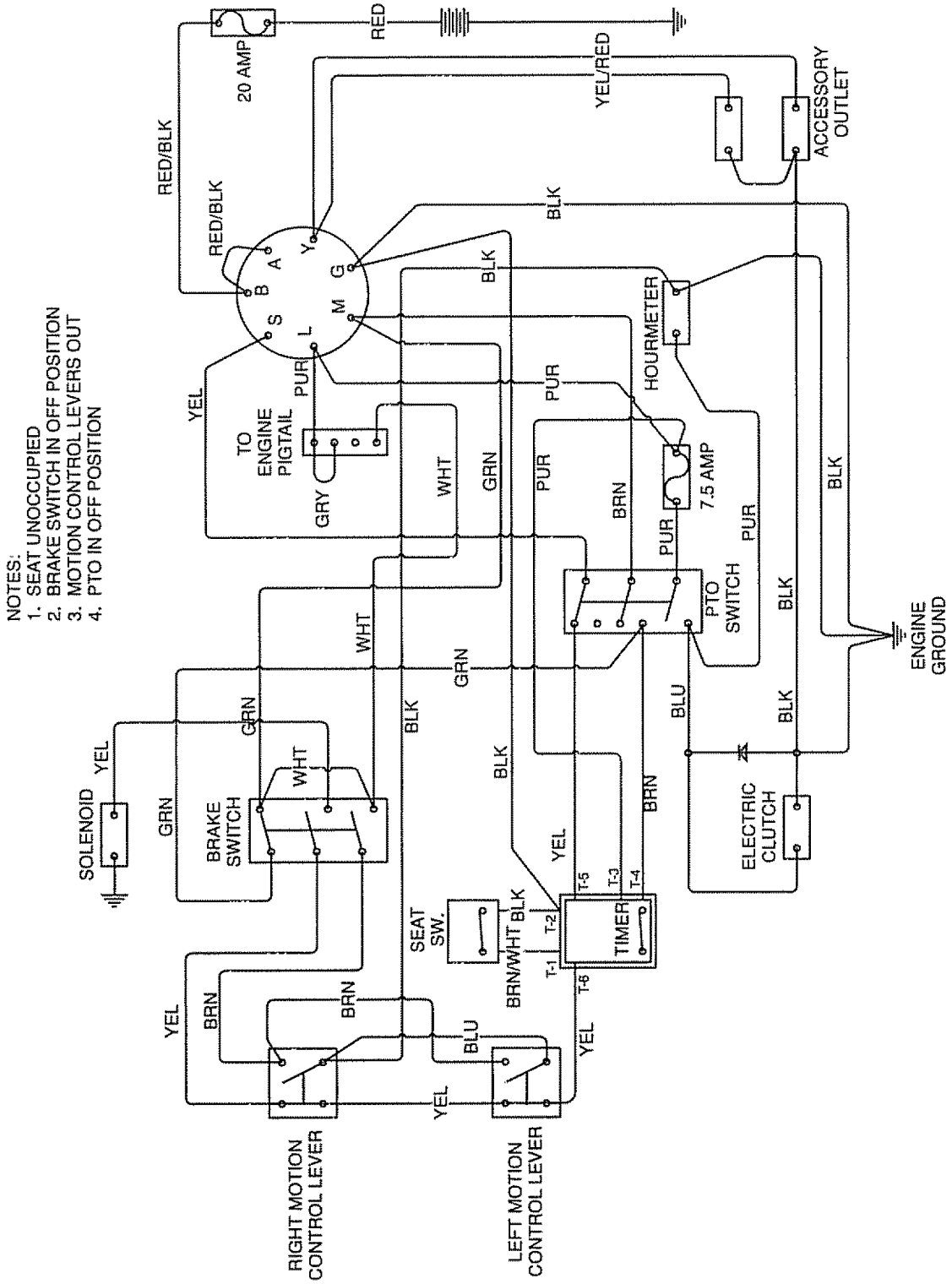

- NOTES:
1. SEAT UNOCCUPIED
 2. BRAKE SWITCH IN OFF POSITION
 3. MOTION CONTROL LEVERS OUT
 4. PTO IN OFF POSITION



TECHNICAL DATA

	MZ6128 / 966502301	MZ28ZT BF / 966582501
Engine		
Manufacturer	Briggs & Stratton ¹⁾	Briggs & Stratton ¹⁾
Type	ELS	Endurance
Power	28 HP ²⁾	28 HP ²⁾
Lubrication	Pressure w/ Oil Filter	Pressure w/ Oil Filter
Fuel	Min 87 octane unleaded (Max ethyl alcohol 10%, Max MTBE 15%)	Min 87 octane unleaded (Max ethyl alcohol 10%, Max MTBE 15%)
Fuel tanks capacity	5 gallons / 9 liters	5 gallons / 9 liters
Cooling	Air cooled	Air cooled
Alternator	12v 15 amp @ 3600 rpm	12v 15 amp @ 3600 rpm
Starter	Electric	Electric
Transmission		
Transmission	ZT-3400 Hydro Gear	ZT-3400 Hydro Gear
Speed and direction controls	Dual levers, foam gripped	Dual levers, foam gripped
Speed forward	0-9 mph - 0-17.7 Km/h	0-9 mph - 0-17.7 Km/h
Speed reverse	0-5 mph - 0-9.7 Km/h	0-5 mph - 0-9.7 Km/h
Brakes	Mechanical parking brake	Mechanical parking brake
Front caster tires, smooth tread	13 x 6.5	13 x 6.5
Rear tires, turf pneumatic	23 x 10.50 4 ply	23 x 10.50 4 ply
Tire pressures	15 PSI / 103 kPa / 1 bar	15 PSI / 103 kPa / 1 bar

¹⁾ See the Engine Manufacturer's manual for engine specifications.

²⁾ The power rating of the engines indicated is the average net power output (at specified rpm) of a typical production engine for the engine model measured to SAE standard J1349/ISO1585. Mass production engines may differ from this value. Actual power output for the engine installed in the final machine will depend on the operating speed, environmental conditions and other variables.

TECHNICAL DATA

	MZ6128 / 966502301	MZ28ZT BF / 966582501
Frame		
Cutting Width	61" (155 cm)	-
Cutting Height	1"-4½" (2.5-11.4 cm)	1"-4½" (2.5-11.4 cm)
Uncut Circle	0	0
Number of Blades	3	-
Blade Length	21" / 53.3 cm	-
Nose Roller	Yes	-
Sprung Seat	Suspension	Suspension
Hinged Arm Rests	Yes	Yes
Hour Meter	Yes	Yes
Blade Engagement	200 ft-lb Warner	200 ft-lb Warner
Deck Construction	11 gauge fabricated	-
Productivity	4 acres/h / 16,187 m ² /h	-
Dimension		
Weight	770 lbs / 349 kg	600 lbs / 272 kg
Base Machine Length	75½" / 192 cm	75½" / 192 cm
Base Machine Height	42" / 107 cm	42" / 107 cm
Base Machine Width	49" / 125 cm	49" / 125 cm
Overall Width, Chute Up	62¼" / 158 cm	-
Overall Width, Chute Down	76" / 193 cm	-

TECHNICAL DATA

	FD52M / 966582601	FD61M / 966582701
Frame		
Cutting Width	52" (132 cm)	61" (155 cm)
Cutting Height	1'-4½" (2.5-11.4 cm)	1'-4½" (2.5-11.4 cm)
Uncut Circle	0	0
Number of Blades	3	3
Blade Length	18" / 46 cm	21" / 53.3 cm
Nose Roller	Yes	Yes
Blade Engagement	200 ft-lb Warner	200 ft-lb Warner
Deck Construction	11 gauge fabricated	11 gauge fabricated
Productivity	3.5 acres/h / 14,167 m2/h	4 acres/h / 16,187 m2/h

TECHNICAL DATA

Torque Specifications

Hex Head Cap Screws

The torque values shown should be used as a general guideline when specific torque values are not given

U.S. Standard Hardware

Shank Size (Diameter in inches, fine or coarse thread)	Grade	SAE Grade 5		SAE Grade 8		Flangelock Screw w/Flangelock Nut	
	ft./lbs	ft./lbs	Nm	ft./lbs	Nm	ft./lbs	Nm
	1/4	9	12	13	18		
	5/16	18	24	28	38	24	33
	3/8	31	42	46	62	40	54
	7/16	50	68	75	108		
	1/2	75	102	115	156		
	9/16	110	150	165	224		
	5/8	150	203	225	305		
	3/4	250	339	370	502		
	7/8	378	513	591	801		
	1 1/8	782	1060	1410	1912		

** Grade 5 - Minimum commercial quality (lower quality not recommended)

Metric Standard Hardware

Shank Size (Diameter in millimeters, fine or coarse thread)	Grade	Grade 8.8		Grade 10.9		Grade 12.9	
	ft./lbs	ft./lbs	Nm	ft./lbs	Nm	ft./lbs	Nm
	M4	1.5	2	2.2	3	2.7	3.6
	M5	3	4	4.5	6	5.2	7
	M6	5.2	7	7.5	10	8.2	11
	M7	8.2	11	12	16	15	20
	M8	13.5	18	18.8	25	21.8	29
	M10	24	32	35.2	47	43.5	58
	M12	43.5	58	62.2	83	75	100
	M14	70.5	94	100	133	119	159
	M16	108	144	147	196	176	235
	M18	142	190	202	269	242	323
	M20	195	260	275	366	330	440
	M22	276	368	390	520	471	628
	M24	353	470	498	664	596	794
	M27	530	707	474	996	904	1205

CONFORMITY CERTIFICATES

USA requirements

Labels are placed on the engine and/or in the engine compartment stating that the machine will fulfill the requirements. This is also applicable to special requirements for any of the states, (California emission rules etc.) Do not remove any of these labels. Certificates can also be supplied with the machine at delivery or written in the Engine manual. Take care of them as they are valuable documents.

CE requirements

The Declaration of Conformity is included in the literature packet.

SERVICE JOURNAL

Action	Date, mtr reading, stamp, sign
Delivery Service	
1. Charge the battery.	<input type="checkbox"/>
2. Adjust the tire pressure of all wheels to 15 PSI (1 bar).	<input type="checkbox"/>
3. Mount the steering controls in the normal position.	<input type="checkbox"/>
4. Connect the contact box to the cable for the seat's safety switch.	<input type="checkbox"/>
5. Check that the right amount of oil is in the engine.	<input type="checkbox"/>
6. Adjust the position of the steering controls.	<input type="checkbox"/>
7. Fill with fuel and open the fuel shut off valve.	<input type="checkbox"/>
8. Start the engine	<input type="checkbox"/>
9. Check that there is drive to both wheels.	<input type="checkbox"/>
10. Check the mower deck adjustment.	<input type="checkbox"/>
11. Check:	
Safety switch for the parking brake.	<input type="checkbox"/>
Safety switch for the mower deck	<input type="checkbox"/>
Safety switch in the seat.	<input type="checkbox"/>
Safety switch in the steering controls.	<input type="checkbox"/>
Parking brake functionality.	<input type="checkbox"/>
Driving forward.	<input type="checkbox"/>
Driving backward	<input type="checkbox"/>
Engaging the blades.	<input type="checkbox"/>
12. Check engine high idle speed	<input type="checkbox"/>
13. Inform the customer about:	
Need and advantages of following the service schedule.	<input type="checkbox"/>
Need and advantages of leaving the machine for service.	<input type="checkbox"/>
Effects of service and maintaining a service journal on the machine's resale value.	<input type="checkbox"/>
Application areas for mulching.	<input type="checkbox"/>
14. Fill in the sales papers, etc	Delivery service has been carried out. No remaining notes. Certified:



SERVICE JOURNAL

Action	Date, mtr reading, stamp, sign
<p>After 10 hours</p> <ol style="list-style-type: none">1. Change the engine oil.2. Change the oil filter3. Check hydraulic oil level.4. Inspect hydraulic hoses.5. Inspect hydraulic belt6. Inspect hydraulic filter.7. Check neutral position.8. Check safety system9. Check seat belt.10. Check fuel system for leaks.11. Inspect safety guards and shields.12. Check brake adjustment.	<p style="text-align: center;"><input type="checkbox"/> <input type="checkbox"/> <input type="checkbox"/> <input type="checkbox"/> <input type="checkbox"/> <input type="checkbox"/> <input type="checkbox"/> <input type="checkbox"/> <input type="checkbox"/> <input type="checkbox"/> <input type="checkbox"/> <input type="checkbox"/></p>



SERVICE JOURNAL

Action	Date, mtr reading, stamp, sign
<p>Daily Service</p> <ol style="list-style-type: none">1. Clean debris from mower.2. Check engine oil level.3. Check the tire pressures.4. Check underside of deck5. Inspect deck pulleys6. Check/clean the engine's cooling air intake.7. Check safety system8. Check seat belt.9. Check fuel system for leaks10. Inspect safety guards and shields11. Check brake adjustment.	<p><input type="checkbox"/></p> <p><input type="checkbox"/></p> <p><input type="checkbox"/></p> <p><input type="checkbox"/></p> <p><input type="checkbox"/></p> <p><input type="checkbox"/></p> <p><input type="checkbox"/></p> <p><input type="checkbox"/></p> <p><input type="checkbox"/></p> <p><input type="checkbox"/></p> <p><input type="checkbox"/></p>



SERVICE JOURNAL

Action	Date, mtr reading, stamp, sign
<p>25-Hour Service</p> <ol style="list-style-type: none">1. Check the fuel pump's air filter2. Sharpen/Replace mower blades if required.3. Check the tire pressures.4. Check battery with cables5. Lubricate according to lubrication chart.6. Check/clean the engine's cooling air intake.7. Clean the air cleaner's pre-filter (foam)	<p><input type="checkbox"/></p> <p><input type="checkbox"/></p> <p><input type="checkbox"/></p> <p><input type="checkbox"/></p> <p><input type="checkbox"/></p> <p><input type="checkbox"/></p> <p><input type="checkbox"/></p>



SERVICE JOURNAL

Action	Date, mtr reading, stamp, sign
100-Hour Service	
1 Grease fittings (caster pivots and caster wheels)	<input type="checkbox"/>
2 Inspect dampeners	<input type="checkbox"/>
3 Inspect frame	<input type="checkbox"/>
4 Inspect throttle cable	<input type="checkbox"/>
5 Inspect hardware	<input type="checkbox"/>
6 Check the tire pressures	<input type="checkbox"/>
7 Change the engine oil and filter	<input type="checkbox"/>
8 Change air filter	<input type="checkbox"/>
9 Inspect spark plug	<input type="checkbox"/>
10 Inspect fuel filter	<input type="checkbox"/>
11 Check engine RPM	<input type="checkbox"/>
12 Clean underside of deck	<input type="checkbox"/>
13 Check blade pitch	<input type="checkbox"/>
14 Grease blade spindles	<input type="checkbox"/>
15 Inspect spindle bearings	<input type="checkbox"/>
16 Inspect deck belt and blades	<input type="checkbox"/>
17 Inspect idler arm bearings	<input type="checkbox"/>
18 Inspect deck idler pulleys	<input type="checkbox"/>
19 Check hydraulic oil level	<input type="checkbox"/>
20 Inspect hydraulic filter	<input type="checkbox"/>
21 Inspect hydraulic drive belt	<input type="checkbox"/>
22 Inspect hydraulic hoses	<input type="checkbox"/>
23 Check neutral position	<input type="checkbox"/>
24 Inspect battery connections	<input type="checkbox"/>
25 Check safety system	<input type="checkbox"/>
26 Check seat belt	<input type="checkbox"/>
27 Check fuel system for leaks	<input type="checkbox"/>
28 Inspect safety guards and shields	<input type="checkbox"/>
29 Check brake adjustment	<input type="checkbox"/>



SERVICE JOURNAL

Action	Date, mtr reading, stamp, sign
300-Hour Service	
1. Grease fittings (caster pivots and caster wheels)	<input type="checkbox"/>
2. Inspect dampeners	<input type="checkbox"/>
3. Inspect frame	<input type="checkbox"/>
4. Inspect throttle cable	<input type="checkbox"/>
5. Inspect hardware	<input type="checkbox"/>
6. Check the tire pressures	<input type="checkbox"/>
7. Change the engine oil and filter	<input type="checkbox"/>
8. Change air filter	<input type="checkbox"/>
9. Inspect spark plug	<input type="checkbox"/>
10. Inspect fuel filter	<input type="checkbox"/>
11. Check engine RPM	<input type="checkbox"/>
12. Clean underside of deck	<input type="checkbox"/>
13. Check blade pitch	<input type="checkbox"/>
14. Grease blade spindles	<input type="checkbox"/>
15. Inspect spindle bearings	<input type="checkbox"/>
16. Inspect deck belt and blades	<input type="checkbox"/>
17. Inspect idler arm bearings	<input type="checkbox"/>
18. Inspect deck idler pulleys	<input type="checkbox"/>
19. Change hydraulic oil	<input type="checkbox"/>
20. Change hydraulic filter	<input type="checkbox"/>
21. Replace hydraulic drive belt	<input type="checkbox"/>
21. Inspect hydraulic hoses	<input type="checkbox"/>
22. Check neutral position	<input type="checkbox"/>
23. Inspect battery connections	<input type="checkbox"/>
24. Load test battery	<input type="checkbox"/>
25. Clean electrical connections	<input type="checkbox"/>
26. Inspect the clutch	<input type="checkbox"/>
24. Check safety system	<input type="checkbox"/>
25. Check seat belt	<input type="checkbox"/>
26. Check fuel system for leaks	<input type="checkbox"/>
27. Inspect safety guards and shields	<input type="checkbox"/>
28. Check brake adjustment	<input type="checkbox"/>



SERVICE JOURNAL

Action	Date, mtr reading, stamp, sign
<p>At least once each year</p> <ol style="list-style-type: none">1. Clean the engine's cooling air intake2. Replace the air cleaner's pre-filter (foam).3. Replace the air filter's paper cartridge.4. Change the engine oil.5. Replace the engine oil filter6. Check/adjust the cutting height7. Check/adjust the parking brake8. Clean/Change the spark plugs9. Inspect spark plug10. Check the engine valve clearance	<p><input type="checkbox"/></p> <p><input type="checkbox"/></p> <p><input type="checkbox"/></p> <p><input type="checkbox"/></p> <p><input type="checkbox"/></p> <p><input type="checkbox"/></p> <p><input type="checkbox"/></p> <p><input type="checkbox"/></p> <p><input type="checkbox"/></p> <p><input type="checkbox"/></p>



