

# OPERATOR'S MANUAL

# CRAFTSMAN®

## PROFESSIONAL

## 10 in. SLIDING COMPOUND MITER SAW WITH LASER DOUBLE INSULATED

Model No.  
315.212010

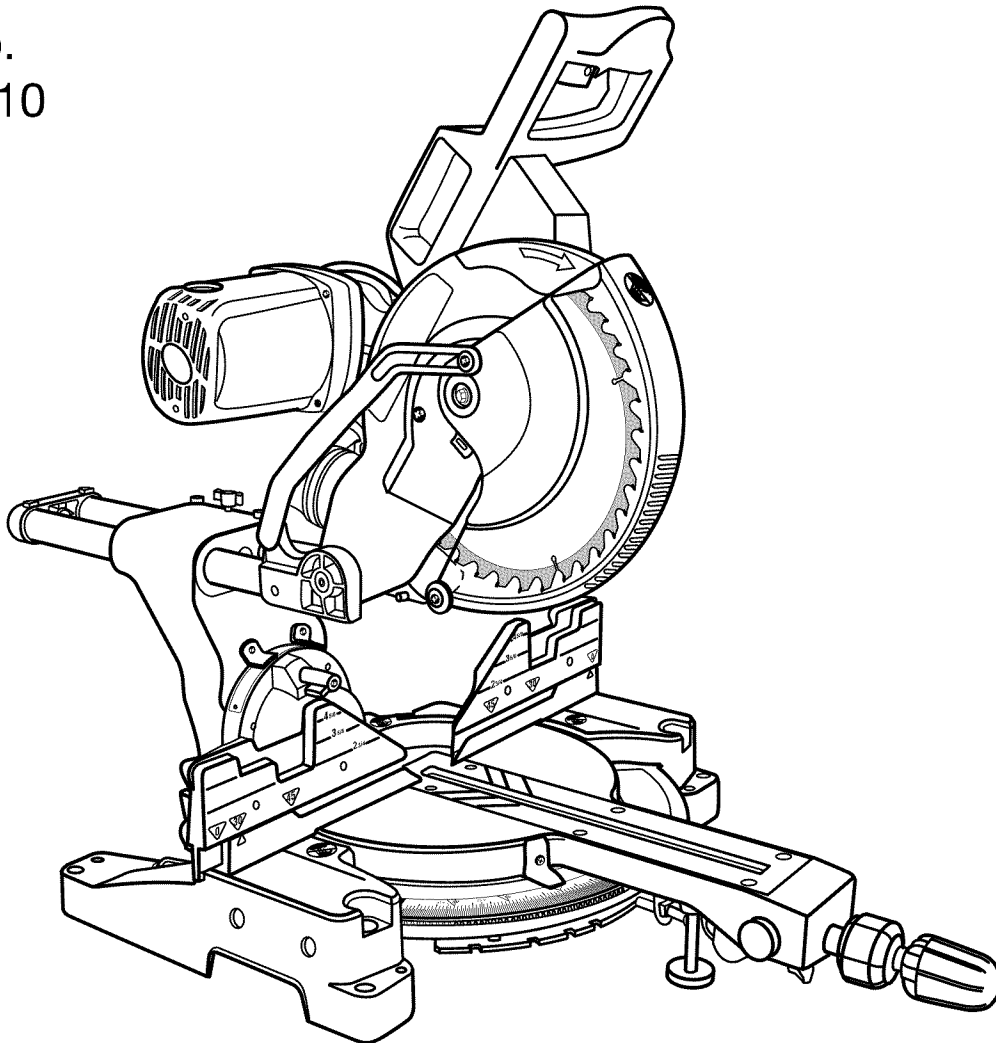

**WARNING:** To reduce the risk of injury, the user must read and understand the operator's manual before using this product.

Customer Help Line: 1-800-932-3188

Sears, Roebuck and Co., 3333 Beverly Rd., Hoffman Estates, IL 60179 USA  
Visit the Craftsman web page: [www.sears.com/craftsman](http://www.sears.com/craftsman)

983000-982  
2-14-07 (REV:02)

Save this manual for future reference



# TABLE OF CONTENTS

■ Warranty .....	2
■ Introduction .....	2
■ General Safety Rules .....	3-4
■ Specific Safety Rules .....	4-5
■ Symbols .....	6-7
■ Electrical .....	8
■ Glossary of Terms .....	9
■ Features .....	10-12
■ Tools Needed .....	12
■ Loose Parts .....	13
■ Assembly .....	14-24
■ Operation .....	24-33
■ Maintenance .....	34-37
■ Exploded View .....	38-51
■ Parts Ordering/Service .....	Back Page

## WARRANTY

### ONE YEAR FULL WARRANTY ON CRAFTSMAN TOOL

If this Craftsman tool fails due to a defect in material or workmanship within one year from the date of purchase, **CONTACT THE NEAREST SEARS PARTS & REPAIR CENTER at 1-800-4-MY-HOME®** and Sears will repair it, free of charge. This warranty applies only while this product is in the United States.

If this tool is used for commercial or rental purposes, this warranty will apply for only ninety days from the date of purchase.

This warranty gives you specific legal rights, and you may also have other rights which vary from state to state.

**Sears, Roebuck and Co., Dept. 817WA, Hoffman Estates, IL 60179**

## INTRODUCTION

This tool has many features for making its use more pleasant and enjoyable. Safety, performance, and dependability have been given top priority in the design of this product making it easy to maintain and operate.

# GENERAL SAFETY RULES

 **WARNING: Read and understand all instructions.** Failure to follow all instructions listed below, may result in electric shock, fire and/or serious personal injury.

## READ ALL INSTRUCTIONS

- **KNOW YOUR POWER TOOL.** Read the operator's manual carefully. Learn the applications and limitations as well as the specific potential hazards related to this tool.
- **GUARD AGAINST ELECTRICAL SHOCK BY PREVENTING BODY CONTACT WITH GROUNDED SURFACES.** For example: pipes, radiators, ranges, refrigerator enclosures.
- **KEEP GUARDS IN PLACE** and in good working order.
- **REMOVE ADJUSTING KEYS AND WRENCHES.** Form habit of checking to see that keys and adjusting wrenches are removed from tool before turning it on.
- **KEEP WORK AREA CLEAN.** Cluttered areas and benches invite accidents. **DO NOT** leave tools or pieces of wood on the tool while it is in operation.
- **DO NOT USE IN DANGEROUS ENVIRONMENTS.** Do not use power tools in damp or wet locations or expose to rain. Keep the work area well lit.
- **KEEP CHILDREN AND VISITORS AWAY.** All visitors should wear safety glasses and be kept a safe distance from work area. Do not let visitors contact tool or extension cord while operating.
- **MAKE WORKSHOP CHILDPROOF** with padlocks, master switches, or by removing starter keys.
- **DON'T FORCE THE TOOL.** It will do the job better and safer at the feed rate for which it was designed.
- **USE THE RIGHT TOOL.** Do not force the tool or attachment to do a job for which it was not designed.
- **USE THE PROPER EXTENSION CORD.** Make sure your extension cord is in good condition. Use only a cord heavy enough to carry the current your product will draw. An undersized cord will cause a drop in line voltage resulting in loss of power and overheating. A wire gauge size (A.W.G.) of at least **14** is recommended for an extension cord 25 feet or less in length. If in doubt, use the next heavier gauge. The smaller the gauge number, the heavier the cord.
- **DRESS PROPERLY.** Do not wear loose clothing, neckties, or jewelry that can get caught and draw you into moving parts. Rubber gloves and nonskid footwear are recommended when working outdoors. Also wear protective hair covering to contain long hair.
- **ALWAYS WEAR SAFETY GLASSES WITH SIDE SHIELDS.** Everyday eyeglasses have only impact-resistant lenses, they are **NOT** safety glasses.
- **SECURE WORK.** Use clamps or a vise to hold work when practical, it is safer than using your hand and frees both hands to operate the tool.
- **DO NOT OVERREACH.** Keep proper footing and balance at all times.
- **MAINTAIN TOOLS WITH CARE.** Keep tools sharp and clean for better and safer performance. Follow instructions for lubricating and changing accessories.
- **DISCONNECT TOOLS.** When not in use, before servicing, or when changing attachments, blades, bits, cutters, etc., all tools should be disconnected from power source.
- **AVOID ACCIDENTAL STARTING.** Be sure switch is off when plugging in any tool.
- **USE RECOMMENDED ACCESSORIES.** Consult the operator's manual for recommended accessories. The use of improper accessories may result in injury.
- **NEVER STAND ON TOOL.** Serious injury could occur if the tool is tipped.
- **CHECK DAMAGED PARTS.** Before further use of the tool, a guard or other part that is damaged should be carefully checked to determine that it will operate properly and perform its intended function. Check for alignment of moving parts, binding of moving parts, breakage of parts, mounting and any other conditions that may affect its operation. A guard or other part that is damaged must be properly repaired or replaced by an authorized service center to avoid risk of personal injury.
- **USE THE RIGHT DIRECTION OF FEED.** Feed work into a blade, cutter, or sanding spindle against the direction or rotation of the blade, cutter, or sanding spindle only.
- **NEVER LEAVE TOOL RUNNING UNATTENDED. TURN THE POWER OFF.** Don't leave tool until it comes to a complete stop.
- **PROTECT YOUR LUNGS.** Wear a face or dust mask if the cutting operation is dusty.
- **PROTECT YOUR HEARING.** Wear hearing protection during extended periods of operation.
- **DO NOT ABUSE CORD.** Never carry tool by the cord or yank it to disconnect from receptacle. Keep cord from heat, oil, and sharp edges.
- **USE OUTDOOR EXTENSION CORDS.** When tool is used outdoors, use only extension cords with approved ground connection that are intended for use outdoors and so marked.
- **KEEP BLADES CLEAN, SHARP, AND WITH SUFFICIENT SET.** Sharp blades minimize stalling and kickback.
- **BLADE COASTS AFTER BEING TURNED OFF.**

# GENERAL SAFETY RULES

- **NEVER USE IN AN EXPLOSIVE ATMOSPHERE.** Normal sparking of the motor could ignite fumes.
- **INSPECT TOOL CORDS PERIODICALLY.** If damaged, have repaired by a qualified service technician at an authorized service facility. The conductor with insulation having an outer surface that is green with or without yellow stripes is the equipment-grounding conductor. If repair or replacement of the electric cord or plug is necessary, do not connect the equipment-grounding conductor to a live terminal. Repair or replace a damaged or worn cord immediately. Stay constantly aware of cord location and keep it well away from the rotating blade.
- **INSPECT EXTENSION CORDS PERIODICALLY** and replace if damaged.
- **POLARIZED PLUGS.** To reduce the risk of electric shock, this tool has a polarized plug (one blade is wider than the other). This plug will fit in a polarized outlet only one way. If the plug does not fit fully in the outlet, reverse the plug. If it still does not fit, contact a qualified electrician to install the proper outlet. Do not change the plug in any way.
- **KEEP TOOL DRY, CLEAN, AND FREE FROM OIL AND GREASE.** Always use a clean cloth when cleaning. Never use brake fluids, gasoline, petroleum-based products, or any solvents to clean tool.
- **STAY ALERT AND EXERCISE CONTROL.** Watch what you are doing and use common sense. Do not operate tool when you are tired. Do not rush.
- **DO NOT USE TOOL IF SWITCH DOES NOT TURN IT ON AND OFF.** Have defective switches replaced by an authorized service center.
- **USE ONLY CORRECT BLADES.** Do not use blades with incorrect size holes. Never use blade washers or blade bolts that are defective or incorrect. The maximum blade capacity of the saw is 10 in.
- **BEFORE MAKING A CUT, BE SURE ALL ADJUSTMENTS ARE SECURE.**
- **BE SURE BLADE PATH IS FREE OF NAILS.** Inspect for and remove all nails from lumber before cutting.
- **NEVER TOUCH BLADE** or other moving parts during use.
- **NEVER START A TOOL WHEN ANY ROTATING COMPONENT IS IN CONTACT WITH THE WORKPIECE.**
- **DO NOT OPERATE A TOOL WHILE UNDER THE INFLUENCE OF DRUGS, ALCOHOL, OR ANY MEDICATION.**
- **WHEN SERVICING** use only identical replacement parts. Use of any other parts may create a hazard or cause product damage.
- **USE ONLY RECOMMENDED ACCESSORIES** listed in this manual or addendums. Use of accessories that are not listed may cause the risk of personal injury. Instructions for safe use of accessories are included with the accessory.
- **DOUBLE CHECK ALL SETUPS.** Make sure blade is tight and not making contact with saw or workpiece before connecting to power supply.

# SPECIFIC SAFETY RULES

- **FIRMLY CLAMP OR BOLT** the tool to a workbench or table at approximately hip height.
- **KEEP HANDS AWAY FROM CUTTING AREA.** Do not reach underneath work or in blade cutting path with your hands and fingers for any reason. Always turn the power off.
- **ALWAYS SUPPORT LONG WORKPIECES** while cutting to minimize risk of blade pinching and kickback. Saw may slip, walk, or slide while cutting long or heavy boards.
- **ALWAYS USE A CLAMP** to secure the workpiece when possible.
- **BE SURE THE BLADE CLEARS THE WORKPIECE.** Never start the saw with the blade touching the workpiece. Allow motor to come up to full speed before starting cut.
- **MAKE SURE THE MITER TABLE AND SAW ARM (BEVEL FUNCTION) ARE LOCKED IN POSITION BEFORE OPERATING YOUR SAW.** Lock the miter table by securely tightening the miter lock lever. Lock the saw arm (bevel function) by securely tightening the bevel lock lever.
- **USE THIS SAW TO CUT WOOD, WOOD PRODUCTS, AND SOME PLASTICS ONLY. DO NOT CUT METALS, CERAMICS OR MASONRY PRODUCTS.**
- **BEFORE MOVING THE SAW,** unplug the saw then lock the miter, bevel, slide, and power head positions.
- **NEVER USE A LENGTH STOP ON THE FREE SCRAP END OF A CLAMPED WORKPIECE. NEVER** hold onto or bind the free scrap end of the workpiece in any operation. If a work clamp and length stop are used together, they must both be installed on the same side of the saw table to prevent the saw from catching the loose end and kicking up.
- **NEVER** cut more than one piece at a time. **DO NOT STACK** more than one workpiece on the saw table at a time.

## SPECIFIC SAFETY RULES

- **NEVER PERFORM ANY OPERATION FREEHAND.** Always place the workpiece to be cut on the miter table and position it firmly against the fence as a back-stop. Always use the fence.
- **NEVER** hand hold a workpiece that is too small to be clamped. Keep hands clear of the cutting area.
- **NEVER** reach behind, under, or within three inches of the blade and its cutting path with your hands and fingers for any reason.
- **NEVER** reach to pick up a workpiece, a piece of scrap, or anything else that is in or near the cutting path of the blade.
- **AVOID AWKWARD OPERATIONS AND HAND POSITIONS** where a sudden slip could cause your hand to move into the blade. **ALWAYS** make sure you have good balance. **NEVER** operate the miter saw on the floor or in a crouched position.
- **NEVER** stand or have any part of your body in line with the path of the saw blade.
- **ALWAYS** release the power switch and allow the saw blade to stop rotating before raising it out of the workpiece.
- **DO NOT TURN THE MOTOR SWITCH ON AND OFF RAPIDLY.** This could cause the saw blade to loosen and could create a hazard. Should this ever occur, stand clear and allow the saw blade to come to a complete stop. Disconnect the saw from the power supply and securely retighten the blade bolt.
- **IF ANY PART OF THIS MITER SAW IS MISSING** or should break, bend, or fail in any way, or should any electrical component fail to perform properly, shut off the power switch, remove the miter saw plug from the power source and have damaged, missing, or failed parts replaced before resuming operation.
- **IF THE POWER SUPPLY CORD IS DAMAGED,** it must be replaced only by the manufacturer or by an authorized service center to avoid risk.
- **ALWAYS STAY ALERT!** Do not allow familiarity (gained from frequent use of your saw) to cause a careless mistake. **ALWAYS REMEMBER** that a careless fraction of a second is sufficient to inflict severe injury.
- **MAKE SURE WORK AREA HAS AMPLE LIGHTING** to see the work and that no obstructions will interfere with safe operation **BEFORE** performing any work using your saw.
- **ALWAYS TURN OFF THE SAW** before disconnecting it to avoid accidental starting when reconnecting to power supply. **NEVER** leave the saw unattended while connected to a power source.
- **THIS TOOL** has the following markings:
  - a) Wear eye protection.
  - b) Keep hands out of path of saw blade
  - c) Do not operate saw without guards in place.
  - d) Do not perform any operation freehand.
  - e) Never reach around saw blade.
  - f) Turn off tool and wait for saw blade to stop before moving workpiece or changing settings.
  - g) Disconnect power (or unplug tool as applicable) before changing blade or servicing.
  - h) No load speed.
  - i) Blade direction of rotation arrow.
- **ALWAYS MAKE SURE THE SAW BLADE HAS CLEARANCE OF ALL OBSTRUCTIONS BEFORE TURNING THE SAW ON.**
- **MAKE SLIDING CUTS** by pulling the saw forward, then pushing the saw blade down at the front of the workpiece then sliding it back toward the rear of the saw. **DO NOT** pull the saw toward you while making a cut.
- **ALWAYS** carry the tool only by the carrying handles.
- **AVOID** direct eye exposure when using the laser guide.
- **THIS SAW CAN TIP OVER** if the saw head is released suddenly and the saw is not secured to a work surface. **ALWAYS** secure this saw to a stable work surface before any use to avoid serious personal injury.
- **SAVE THESE INSTRUCTIONS.** Refer to them frequently and use to instruct other users. If you loan someone this tool, loan them these instructions also.







 **WARNING:** Some dust created by power sanding, sawing, grinding, drilling, and other construction activities contains chemicals known to cause cancer, birth defects or other reproductive harm. Some examples of these chemicals are:

- lead from lead-based paints,
- crystalline silica from bricks and cement and other masonry products, and
- arsenic and chromium from chemically-treated lumber.

Your risk from these exposures varies, depending on how often you do this type of work. To reduce your exposure to these chemicals: work in a well ventilated area, and work with approved safety equipment, such as those dust masks that are specially designed to filter out microscopic particles.



# SYMBOLS

Some of the following symbols may be used on this tool. Please study them and learn their meaning. Proper interpretation of these symbols will allow you to operate the tool better and safer.

SYMBOL	NAME	DESIGNATION/EXPLANATION
V	Volts	Voltage
A	Amperes	Current
Hz	Hertz	Frequency (cycles per second)
W	Watt	Power
min	Minutes	Time
~	Alternating Current	Type of current
≡	Direct Current	Type or a characteristic of current
$n_0$	No Load Speed	Rotational speed, at no load
	Class II Construction	Double-insulated construction
.../min	Per Minute	Revolutions, strokes, surface speed, orbits etc., per minute
	Wet Conditions Alert	Do not expose to rain or use in damp locations.
	Read The Operator's Manual	To reduce the risk of injury, user must read and understand operator's manual before using this product.
	Eye Protection	Always wear safety goggles or safety glasses with side shields and, as necessary, a full face shield when operating this product.
	Safety Alert	Precautions that involve your safety.
	No Hands Symbol	Failure to keep your hands away from the blade will result in serious personal injury.
	Hot Surface	To reduce the risk of injury or damage, avoid contact with any hot surface.

# SYMBOLS

The following signal words and meanings are intended to explain the levels of risk associated with this product.

SYMBOL	SIGNAL	MEANING
	<b>DANGER:</b>	Indicates an imminently hazardous situation, which, if not avoided, will result in death or serious injury.
	<b>WARNING:</b>	Indicates a potentially hazardous situation, which, if not avoided, could result in death or serious injury.
	<b>CAUTION:</b>	Indicates a potentially hazardous situation, which, if not avoided, may result in minor or moderate injury.
	<b>CAUTION:</b>	(Without Safety Alert Symbol) Indicates a situation that may result in property damage.

## SERVICE

Servicing requires extreme care and knowledge and should be performed only by a qualified service technician. For service we suggest you return the product to your nearest **SEARS PARTS AND REPAIR SERVICE CENTER** for repair. When servicing, use only identical replacement parts.



**WARNING:** To avoid serious personal injury, do not attempt to use this product until you read thoroughly and understand completely the operator's manual. If you do not understand the warnings and instructions in the operator's manual, do not use this product. Call the Craftsman Consumer Helpline at 1-800-932-3188 for assistance.

## WARNING:



The operation of any power tool can result in foreign objects being thrown into your eyes, which can result in severe eye damage. Before beginning power tool operation, always wear safety goggles or safety glasses with side shields and, when needed, a full face shield. We recommend Wide Vision Safety Mask for use over eyeglasses or standard safety glasses with side shields. Always use eye protection which is marked to comply with ANSI Z87.1.

## SAVE THESE INSTRUCTIONS

# ELECTRICAL

## DOUBLE INSULATION

Double insulation is a concept in safety in electric power tools, which eliminates the need for the usual three-wire grounded power cord. All exposed metal parts are isolated from the internal metal motor components with protecting insulation. Double insulated tools do not need to be grounded.

 **WARNING:** The double insulated system is intended to protect the user from shock resulting from a break in the tool's internal insulation. Observe all normal safety precautions to avoid electrical shock.

**NOTE:** Servicing of a product with double insulation requires extreme care and knowledge of the system and should be performed only by a qualified service technician. For service, we suggest you return the product to your nearest Sears or other qualified service center for repair. Always use original factory replacement parts when servicing.

## ELECTRICAL CONNECTION

This product has a precision-built electric motor. It should be connected to a **power supply that is 120 volts, 60 Hz, AC only (normal household current)**. Do not operate this product on direct current (DC). A substantial voltage drop will cause a loss of power and the motor will overheat. If the product does not operate when plugged into an outlet, double-check the power supply.

## EXTENSION CORDS

When using a power tool at a considerable distance from a power source, be sure to use an extension cord that has the capacity to handle the current the product will draw. An undersized cord will cause a drop in line voltage, resulting in overheating and loss of power. Use the chart to determine the minimum wire size required in an extension cord. Only round jacketed cords listed by Underwriter's Laboratories (UL) should be used.

When working outdoors with a product, use an extension cord that is designed for outside use. This type of cord is designated with "WA" on the cord's jacket.

Before using any extension cord, inspect it for loose or exposed wires and cut or worn insulation.

\*\*Ampere rating (on product faceplate)

0-2.0 2.1-3.4 3.5-5.0 5.1-7.0 7.1-12.0 12.1-16.0

Cord Length	Wire Size (A.W.G.)					
25'	16	16	16	16	14	14
50'	16	16	16	14	14	12
100'	16	16	14	12	10	—

\*\*Used on 12 gauge - 20 amp circuit

**NOTE:** AWG = American Wire Gauge

 **WARNING:** Keep the extension cord clear of the working area. Position the cord so that it will not get caught on lumber, tools or other obstructions while you are working with a power tool. Failure to do so can result in serious personal injury.

 **WARNING:** Check extension cords before each use. If damaged replace immediately. Never use product with a damaged cord since touching the damaged area could cause electrical shock resulting in serious injury.

# GLOSSARY OF TERMS

## **Anti-Kickback Pawls (radial arm and table saws)**

A device which, when properly installed and maintained, is designed to stop the workpiece from being kicked back toward the front of the saw during a ripping operation.

## **Arbor**

The shaft on which a blade or cutting tool is mounted.

## **Bevel Cut**

A cutting operation made with the blade at any angle other than 90° to the table surface.

## **Chamfer**

A cut removing a wedge from a block so the end (or part of the end) is angled rather than at 90°.

## **Compound Cut**

A cross cut made with both a miter and a bevel angle.

## **Cross Cut**

A cutting or shaping operation made across the grain or the width of the workpiece.

## **Cutter Head (planers and jointer planers)**

A rotating cutterhead with adjustable blades or knives. The blades or knives remove material from the workpiece.

## **Dado Cut**

A non-through cut which produces a square-sided notch or trough in the workpiece (requires a special blade).

## **Featherboard**

A device used to help control the workpiece by guiding it securely against the table or fence during any ripping operation.

## **FPM or SPM**

Feet per minute (or strokes per minute), used in reference to blade movement.

## **Freehand**

Performing a cut without the workpiece being guided by a fence, miter gauge, or other aids.

## **Gum**

A sticky, sap-based residue from wood products.

## **Heel**

Alignment of the blade to the fence.

## **Kerf**

The material removed by the blade in a through cut or the slot produced by the blade in a non-through or partial cut.

## **Kickback**

A hazard that can occur when the blade binds or stalls, throwing the workpiece back toward operator.

## **Leading End**

The end of the workpiece pushed into the tool first.

## **Miter Cut**

A cutting operation made with the workpiece at any angle to the blade other than 90°.

## **Non-Through Cuts**

Any cutting operation where the blade does not extend completely through the thickness of the workpiece.

## **Push Blocks (for jointer planers)**

Device used to feed the workpiece over the jointer planer cutterhead during any operation. This aid helps keep the operator's hands well away from the cutterhead.

## **Push Blocks and Push Sticks (for table saws)**

Devices used to feed the workpiece through the saw blade during cutting operations. A push stick (not a push block) should be used for narrow ripping operations. These aids help keep the operator's hands well away from the blade.

## **Pilot Hole (drill presses)**

A small hole drilled in a workpiece that serves as a guide for drilling large holes accurately.

## **Resaw**

A cutting operation to reduce the thickness of the workpiece to make thinner pieces.

## **Resin**

A sticky, sap-based substance that has hardened.

## **Revolutions Per Minute (RPM)**

The number of turns completed by a spinning object in one minute.

## **Ripping or Rip Cut**

A cutting operation along the length of the workpiece.

## **Riving Knife/Spreader/Splitter (table saws)**

A metal piece, slightly thinner than the blade, which helps keep the kerf open and also helps to prevent kickback.

## **Saw Blade Path**

The area over, under, behind, or in front of the blade. As it applies to the workpiece, that area which will be or has been cut by the blade.

## **Set**

The distance that the tip of the saw blade tooth is bent (or set) outward from the face of the blade.

## **Snipe (planers)**

Depression made at either end of a workpiece by cutter blades when the workpiece is not properly supported.

## **Through Sawing**

Any cutting operation where the blade extends completely through the thickness of the workpiece.

## **Throw-Back**

The throwing back of a workpiece usually caused by the workpiece being dropped into the blade or being placed inadvertently in contact with the blade.

## **Workpiece or Material**

The item on which the operation is being done.

## **Worktable**

Surface where the workpiece rests while performing a cutting, drilling, planing, or sanding operation.

# FEATURES

## PRODUCT SPECIFICATIONS

Blade Diameter..... 10 in.  
 Arbor..... 5/8 in.  
 No Load Speed..... 5,000 r/min. (RPM)  
 Input..... 120 V, 60 Hz, AC Only, 15 Amps.

Cutting Capacity with Miter at 0°/Bevel 0°:  
 Maximum nominal lumber sizes.....2 x 12, 4 x 4  
 Cutting Capacity with Miter at 45°/Bevel 0°:  
 Maximum nominal lumber sizes..... 2 x 10  
 Cutting Capacity with Miter at 0°/Bevel 45°:  
 Maximum nominal lumber sizes..... 2 x 12  
 Cutting Capacity with Miter at 45°/Bevel 45°:  
 Maximum nominal lumber sizes..... 2 x 10

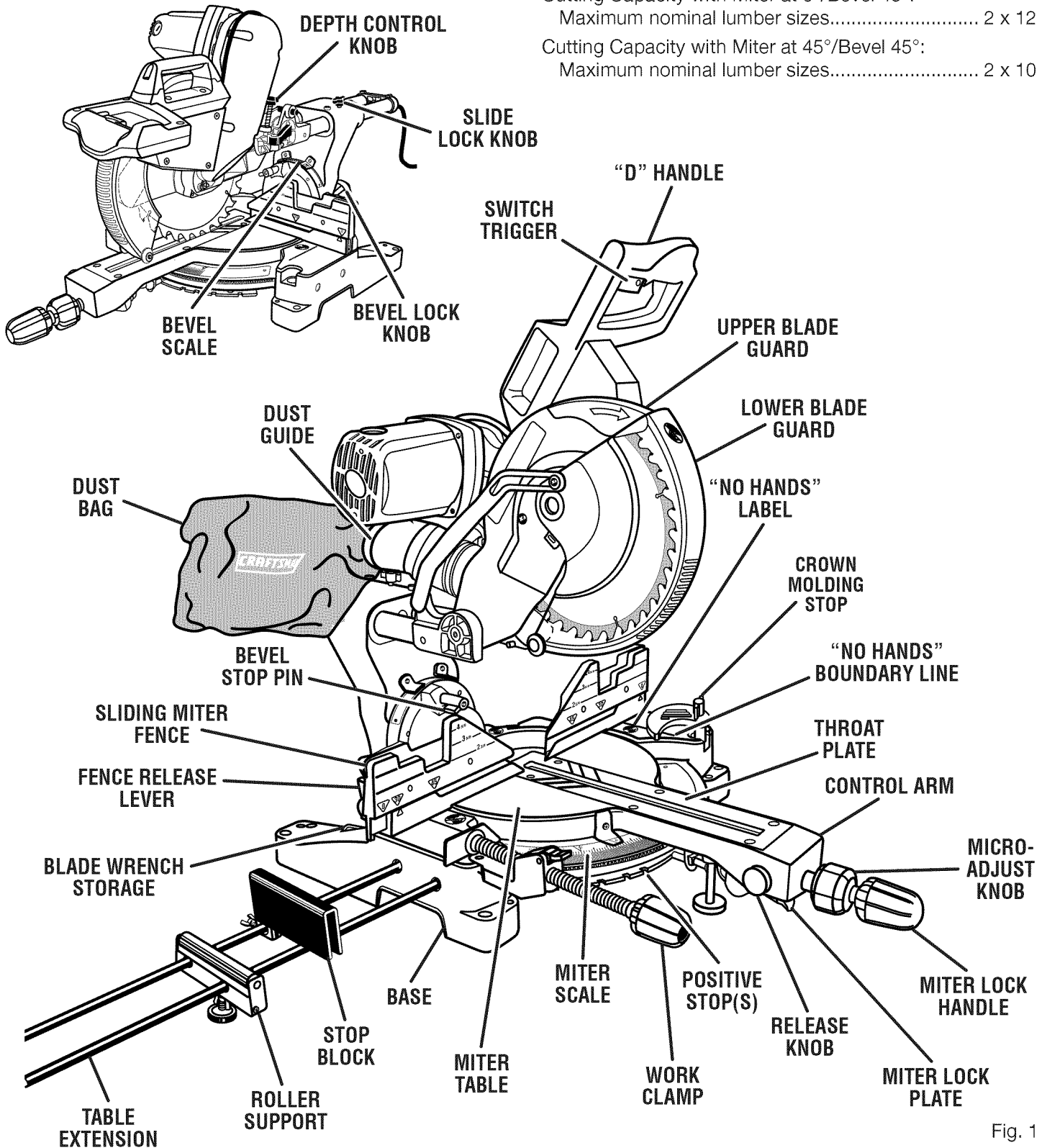

Fig. 1



# FEATURES

## KNOW YOUR COMPOUND MITER SAW

See Figure 1.

The safe use of this product requires an understanding of the information on the tool and in this operator's manual as well as a knowledge of the project you are attempting. Before use of this product, familiarize yourself with all operating features and safety rules.

### 10 in. BLADE

A 10 in. blade is included with your compound miter saw. It will cut materials up to 11-1/2 in. wide, depending upon the angle at which the cut is being made.

### 15 AMP MOTOR

Your saw has a powerful 15 amp belt-driven motor with sufficient power to handle tough cutting jobs. It is made with all ball bearings, and has externally accessible brushes for ease of servicing.

### BEVEL LOCK KNOB

The bevel lock knob securely locks your compound miter saw at desired bevel angles. A positive stop adjustment screw has been provided on each side of the saw arm. These adjustment screws are for making fine adjustments at 0° and 45°.

### BEVEL STOP PIN

The bevel stop pin has several positions:

1. Override (pin pulled completely out)
2. The 0° - 48° position for crown molding (pin pushed in)
3. Stops at 33.9° and 45°

### CARRYING HANDLE

See Figure 2.

For convenience when carrying or transporting the miter saw, a carrying handle has been provided on top of the saw arm. To transport, turn off and unplug the saw, then lower the saw arm and lock it in the down position. Lock saw arm by pushing the lock pin to the left. Lock bevel and miter lock levers; lock slide lock knob.

**NOTE:** DO NOT perform any cutting operation with the saw in the locked position.

### CROWN MOLDING STOP

The crown molding stop makes positioning crown molding vertically against the fence easier.

### ELECTRIC BRAKE

An electric brake has been provided to quickly stop blade rotation after the switch is released.

### LASER GUIDE

For more accurate cuts, a laser guide is included with your miter saw. When used properly, the laser guide makes accurate, precision cutting simple and easy.

### LOWER BLADE GUARD

The lower blade guard is made of shock-resistant, see-through plastic that provides protection from each side of the blade. It retracts over the upper blade guard as the saw is lowered into the workpiece.

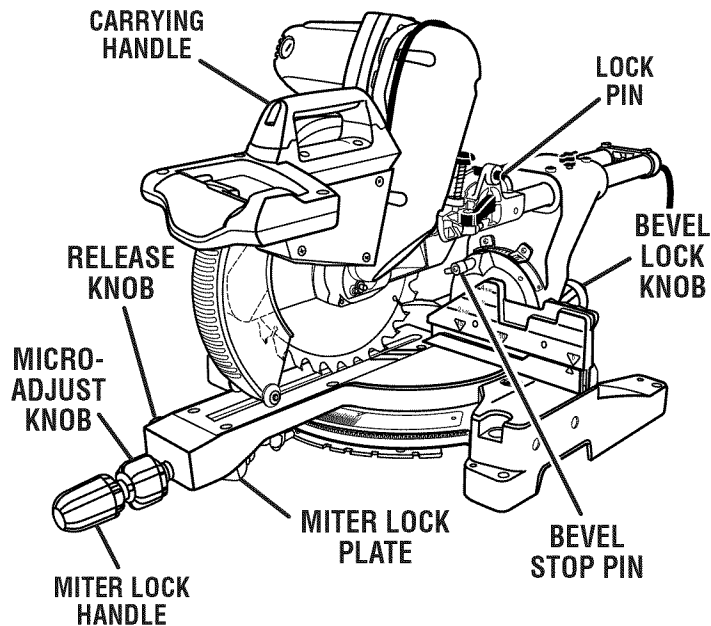

SAW ARM LOCKED IN DOWN POSITION

Fig. 2

### MICRO-ADJUST KNOB

The micro-adjust feature allows rotation of the miter table in small increments for the most accurate cuts. With the miter lock handle unlocked, lift and hold the miter lock plate then push the micro-adjust knob in while giving the knob a slight turn. Once set to the desired position, retighten the miter lock handle then cancel the micro-adjust feature by pulling out the side release knob.

### MITER LOCK HANDLE

See Figure 2.

The miter lock handle securely locks your saw at desired miter angles.

### POSITIVE STOPS ON MITER TABLE

Positive stops have been provided at 0°, 15°, 22.5°, 31.6°, and 45° on both the left and right side of the miter table.

### ROLLER SUPPORT

With the roller support installed, the workpiece will glide smoothly over the table extensions.

### SLIDE BAR

When unlocked, the saw arm will glide forward and backward the length of the slide bar for cutting various workpiece widths.

### SLIDING MITER FENCE

Hold the workpiece securely against the miter fence when making all cuts. The sliding feature allows both fences (left and right) to be moved when making bevel or compound cuts.

Slide the miter fences by pushing and holding the fence release levers. Once the desired position of the fence is determined, release the lever to secure the fence.

# FEATURES

## SPINDLE LOCK BUTTON

See Figure 3.

A spindle lock button has been provided for locking the spindle which keeps the blade from rotating. Depress and hold the lock button while installing, changing, or removing blade.

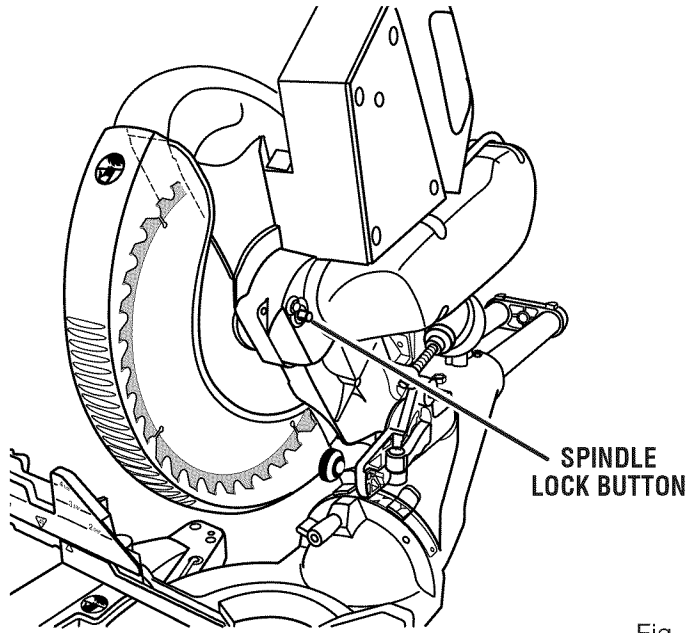

Fig. 3

## SWITCH TRIGGER

See Figure 4.

The saw will not start until you depress the switch lock with your thumb then squeeze the switch trigger. To prevent unauthorized use of the compound miter saw, disconnect it from the power supply and lock the switch in the **OFF** position. To lock the switch, install a padlock (not included) through the hole in the switch trigger. A lock with a long shackle up to 9/32 in. diameter may be used. When the lock is installed and locked, the switch is inoperable. Store the padlock key in another location.

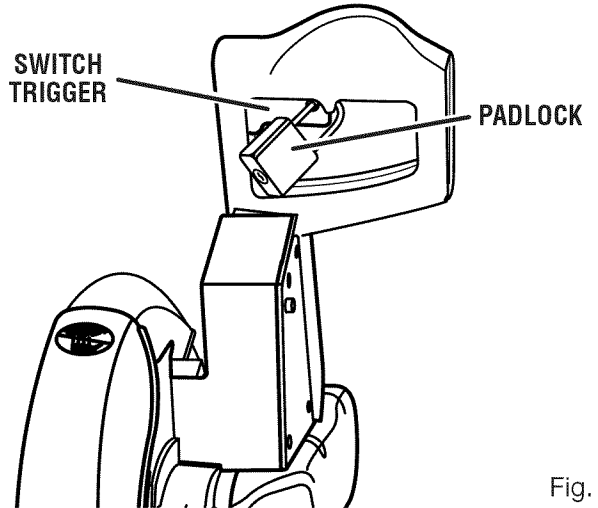

Fig. 4

# TOOLS NEEDED

The following tools (not included) are needed for making adjustments or installing the blade:

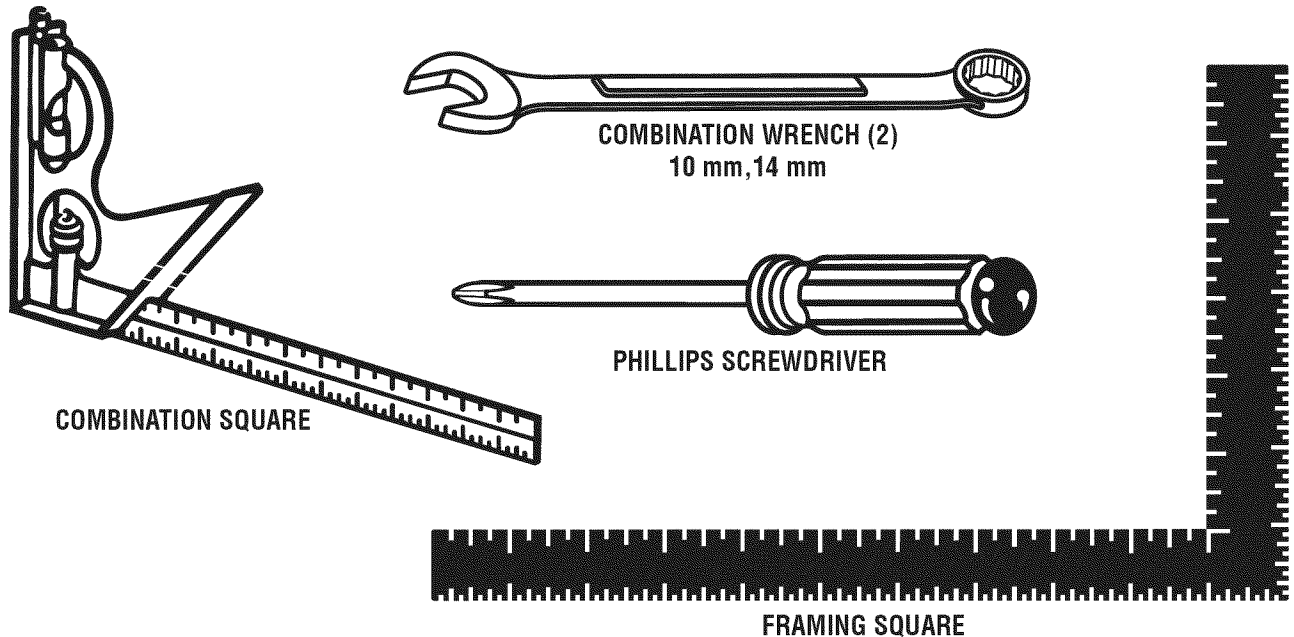

Fig. 5

# LOOSE PARTS

The following items are included with your miter saw:

- Dust Bag
- Dust Guide
- Table Extension (2)
- Clamp Bracket
- Clamp Bracket Screw
- Roller Support
- Leveler with attached Wing Nut
- Stop Block
- Miter Lock Handle
- Work Clamp
- Blade Wrench
- Outer Blade Washer
- Blade Bolt
- Hex Key (4), 1/16 in., 4 mm, 5 mm, and 8 mm
- Crown Molding Stop
- Operator's Manual

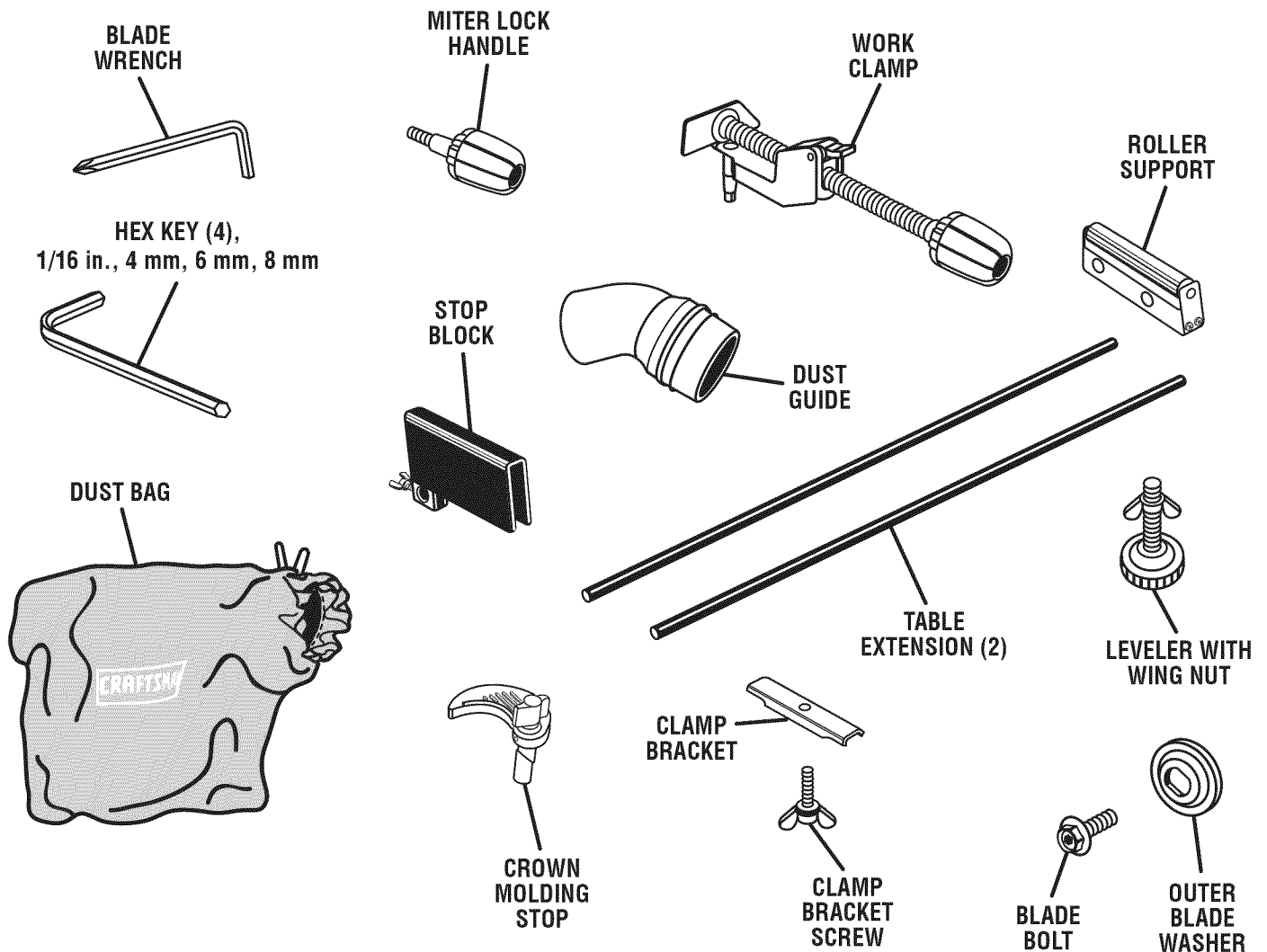

Fig. 6

**WARNING:** The use of attachments or accessories not listed might be hazardous and could cause serious personal injury.

# ASSEMBLY

## UNPACKING

This product requires assembly.

- Carefully lift saw from the carton by the carrying handle and the saw base, and place it on a level work surface.

**NOTE:** This saw is heavy. To avoid back injury, lift with your legs, not your back, and get help when needed.

- This saw has been shipped with the saw arm secured in the down position. To release the saw arm, push down on the top of the saw arm, cut the tie-wrap, and pull out on the lock pin.
- Lift the saw arm by the handle. Hand pressure should remain on the saw arm to prevent sudden rise upon release of the tie wrap.
- Inspect the tool carefully to make sure no breakage or damage occurred during shipping.
- Do not discard the packing material until you have carefully inspected and satisfactorily operated the tool.
- The saw is factory set for accurate cutting. After assembling it, check for accuracy. If shipping has influenced the settings, refer to specific procedures explained in this manual.
- If any parts are damaged or missing, please call 1-800-932-3188 for assistance.

**WARNING:** If any parts are damaged or missing do not operate this tool until the parts are replaced. Failure to heed this warning could result in serious personal injury.

**WARNING:** Do not attempt to modify this tool or create accessories not recommended for use with this tool. Any such alteration or modification is misuse and could result in a hazardous condition leading to possible serious personal injury.

**WARNING:** Do not connect to power supply until assembly is complete. Failure to comply could result in accidental starting and possible serious personal injury.

**WARNING:** Do not start the miter saw without checking for interference between the saw blade and the sliding miter fences. Damage could result to the blade if it strikes the miter fence during operation of the saw.

**WARNING:** Always make sure the compound miter saw is securely mounted to a workbench. Failure to heed this warning can result in serious personal injury.

## MOUNTING HOLES

See Figure 7.

The compound miter saw should be permanently mounted to a firm supporting surface such as a workbench. Four bolt holes have been provided in the saw base for this purpose. Each of the four mounting holes should be bolted securely using 3/8 in. machine bolts, lock washers, and hex nuts (not included). Bolts should be of sufficient length to accommodate the saw base, lock washers, hex nuts, and the thickness of the workbench. Tighten all four bolts or screws securely. Do not use screws if mounting to a leg stand.

The hole pattern for mounting to a workbench is shown in figure 7. Carefully check the workbench after mounting to make sure that no movement can occur during use. If any tipping, sliding, or walking is noted, secure the workbench to the floor before operating.

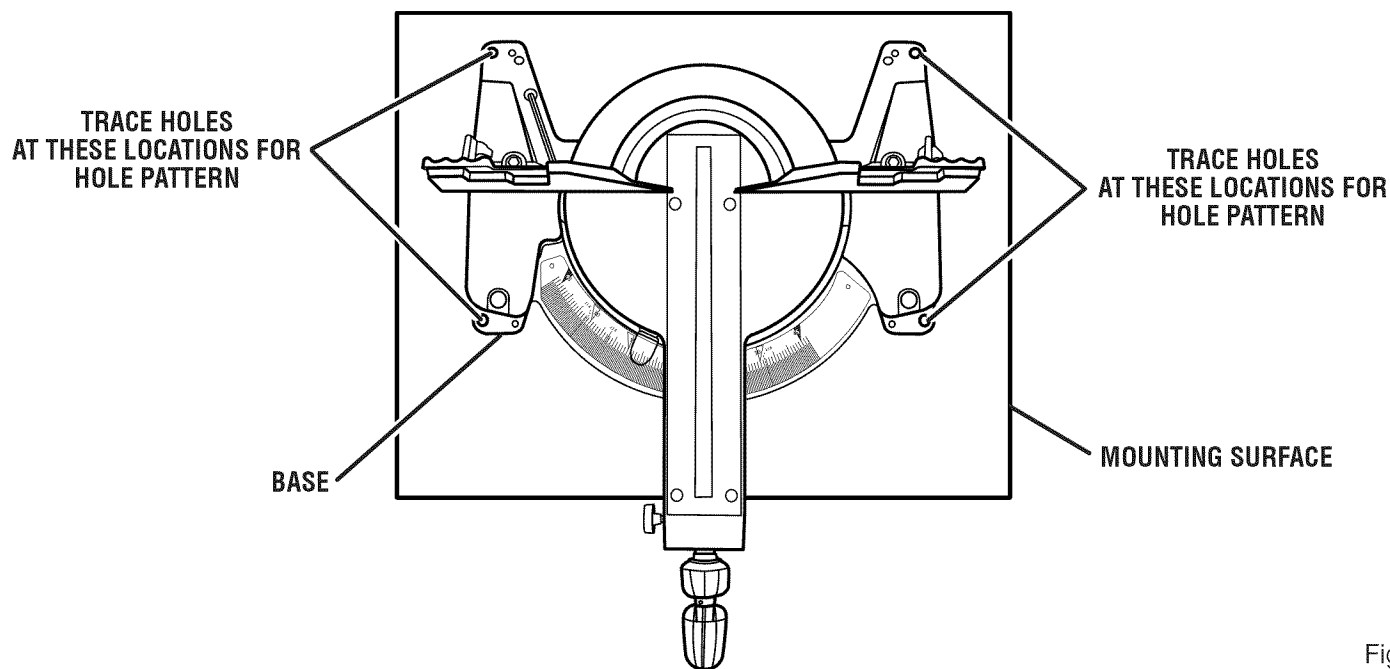

Fig. 7

# ASSEMBLY

**NOTE:** Many of the illustrations in this manual show only portions of the compound miter saw. This is intentional so that we can clearly show points being made in the illustrations. **Never operate the saw without all guards securely in place and in good operating condition.**

## LOCKING / UNLOCKING THE SAW ARM

See Figure 8.

When locking and unlocking the saw arm, it is not necessary to loosen the depth control knob.

### To unlock and raise the saw arm:

- Firmly grasp the “D” handle and apply downward pressure while at the same time pulling the lock pin out and away from the saw housing.
- Release the lock pin and slowly raise the saw arm.

### To relock the saw arm:

- Firmly grasp the “D” handle and apply downward pressure while at the same time pulling the lock pin out and away from the saw housing.
- Release the lock pin allowing it to lock the saw into place.

## USING THE DEPTH STOP

See Figure 9.

When used, the depth stop limits the downward travel of the blade when cutting dados and other non-through cuts.

### To use the depth stop:

- If the saw is in storage or transport position, unlock the saw arm.
- Turn the depth stop to the left position.
- With the depth control knob touching the depth stop, adjust the depth control knob by turning the knob until the desired depth of cut is attained.

**NOTE:** The depth stop must be pushed to the right before locking / unlocking the saw arm.

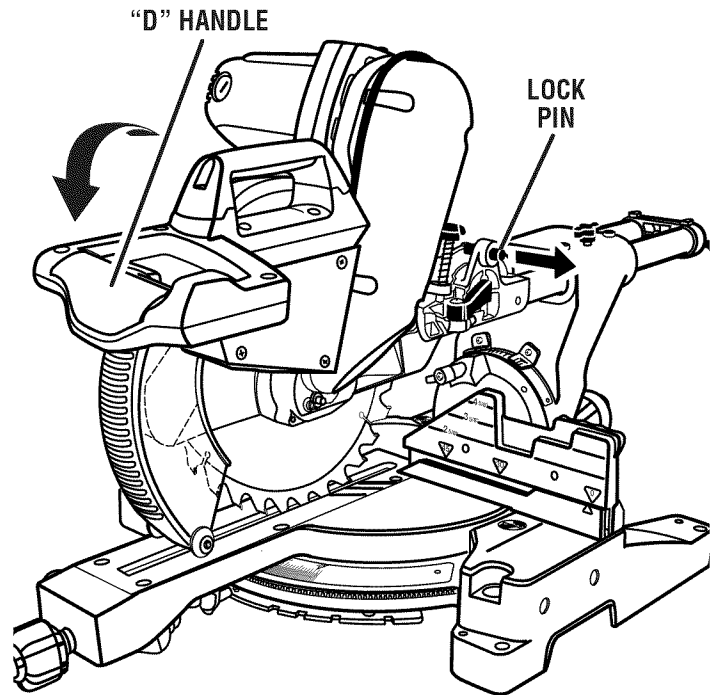

Fig. 8

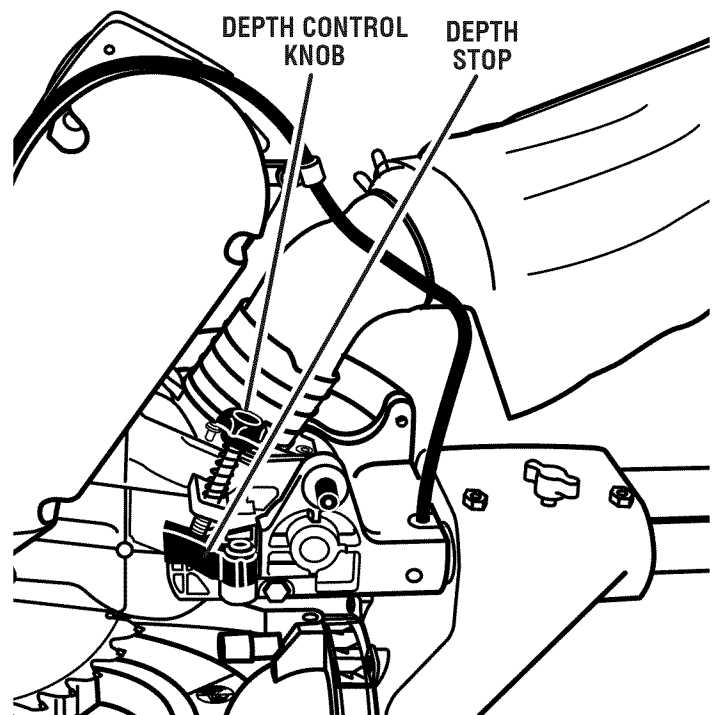

Fig. 9

# ASSEMBLY

## DUST GUIDE

See Figure 10.

Slide the end of the dust guide into the exhaust port in the upper blade guard. Turn the guide so that the open end is facing down or toward the rear of the saw.

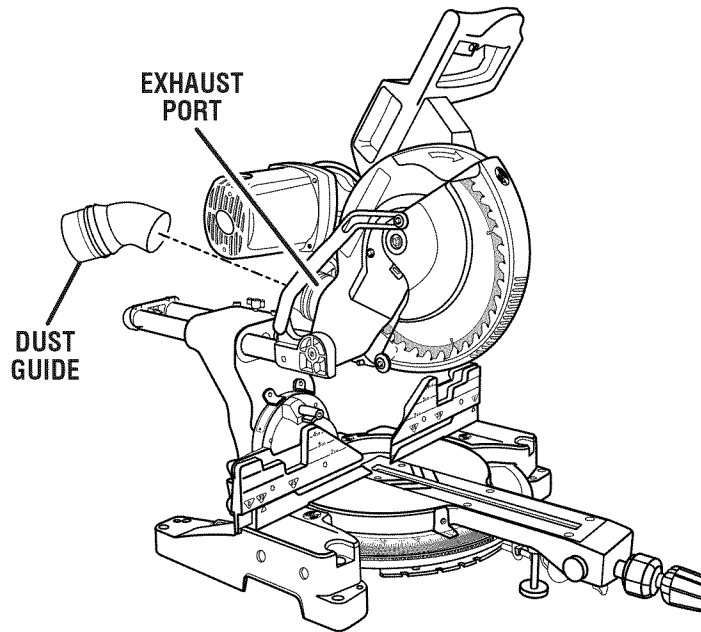

Fig. 10

## DUST BAG

See Figure 11.

A dust bag is provided for use on this miter saw. It fits over the dust guide on the upper blade guard.

### To install:

- Squeeze the two metal clips to open the mouth of the bag and slide it on to the dust guide.
- Release the clips. The metal ring in the bag should lock in between the grooves on the dust guide.

### To remove the dust bag for emptying:

- Reverse the above procedure.

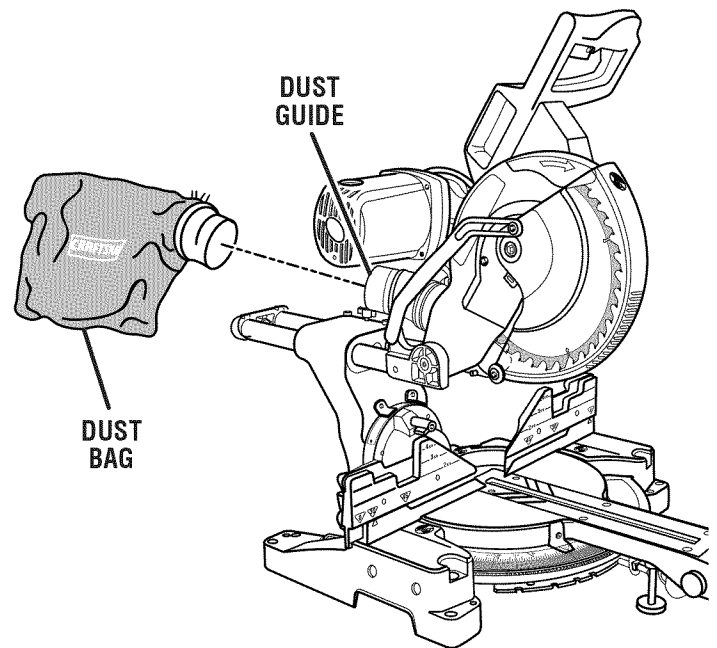

Fig. 11

# ASSEMBLY

## TABLE EXTENSIONS

See Figures 12 - 13.

Table extensions can be installed on either the left or the right side of the base.

### To install:

- Insert the ends of the table extensions into the holes in the side of the base and adjust the extensions to the desired length.
- Secure extensions in place by positioning the clamp bracket under the extension beneath the base. Orient the clamp bracket as shown in figure 13.
- Using the clamp bracket screw, secure the clamp bracket in place.

**NOTE:** The clamp bracket screw threads through the clamp bracket and tightens against bracket support on bottom of base, securing clamp bracket against table extensions.

## ROLLER SUPPORT

See Figure 14.

- Turn the roller support upside down.
- Spin the wing nut on the leveler clockwise until the wing nut is positioned in the middle of the threads.
- Screw the leveler into the center brace of the roller support.
- Turn the roller support upright.
- With the table extensions secured in the saw's base, slide the roller support onto the extensions.
- Tighten the wing nut on the back of the roller support securing it to the table extensions.
- The leveler must sit firmly on the surface the saw is mounted to. Adjust the leveler up or down as needed.
- Once the leveler is in the proper position, turn the lever wing nut until the wing nut is tight against the center brace.

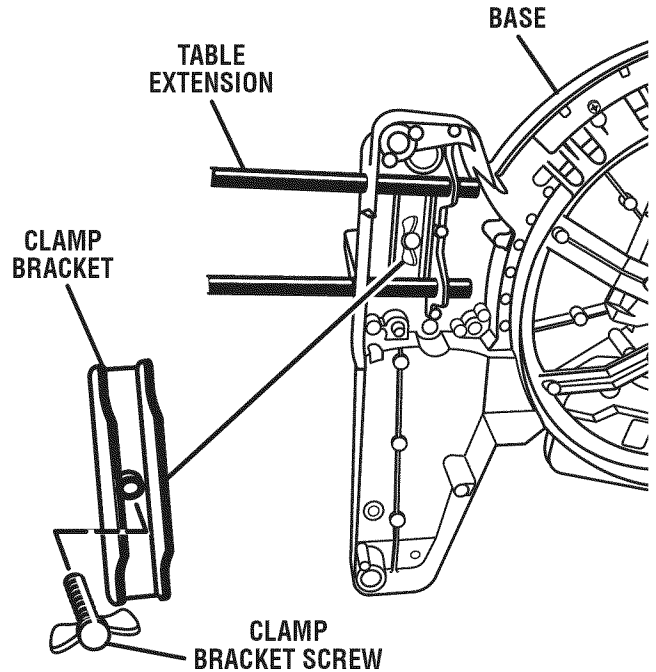

SAW VIEWED FROM BOTTOM

Fig. 13

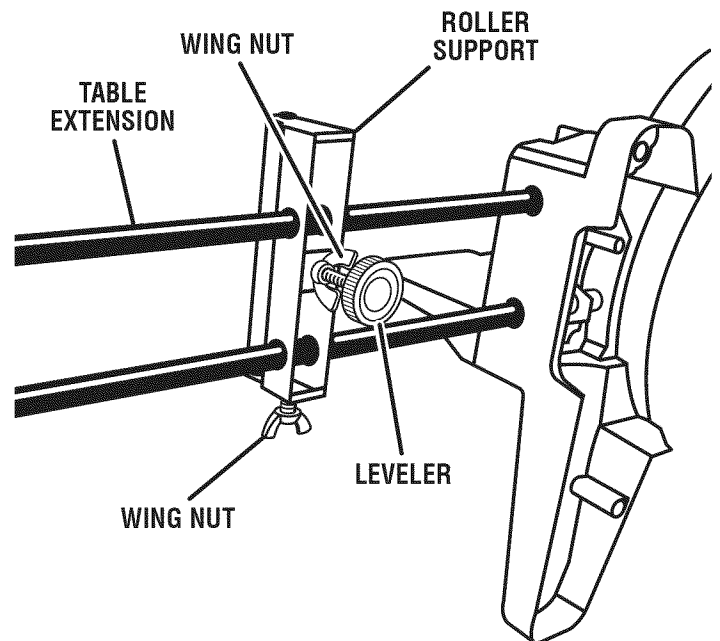

Fig. 14

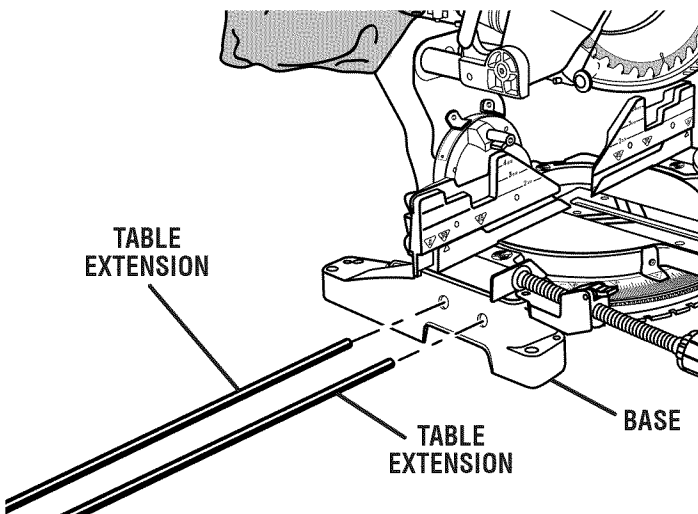

Fig. 12

# ASSEMBLY

## STOP BLOCK

See Figure 15.

The stop block is useful as a stop for making repetitive cuts to the same length. It can be installed on either side of the saw base.

- Slide the stop block on the table extension.
- Adjust the stop block the desired distance from the blade for the cut to be made.
- Tighten small wing screw to secure the stop block to the table extension.
- Make a test cut in scrap material and measure the length of the workpiece.
- Make any necessary adjustments.

## WORK CLAMP

See Figure 16.

**⚠ WARNING:** In some operations, the work clamp assembly may interfere with the operation of the blade guard assembly. Always make sure there is no interference with the blade guard prior to beginning any cutting operation to reduce the risk of serious personal injury.

The work clamp provides greater control by clamping the workpiece to the fence or the table. It also prevents the workpiece from creeping toward the saw blade. This is very helpful when cutting compound miters. Depending on the cutting operation and the size of the workpiece, it may be necessary to use a C-clamp instead of the work clamp to secure the workpiece prior to making the cut. The work clamp can be installed and used on either side of the blade.

### To install the work clamp:

- Place the shaft of the work clamp in either hole on the saw table base.
- Rotate the knob on the work clamp to move it in or out as needed or press the quick release lever for faster positioning.

**NOTE:** The work clamp has a quick release lever that makes positioning of the work clamp effortless.

## TO INSTALL / REPLACE BLADE

See Figures 17 - 19.

**⚠ WARNING:** A 10 in. blade is the maximum blade capacity of the saw. Never use a blade that is too thick to allow outer blade washer to engage with the flats on the spindle. Larger blades will come in contact with the blade guards, while thicker blades will prevent the blade screw from securing the blade on the spindle. Either of these situations could result in a serious accident and can cause serious personal injury.

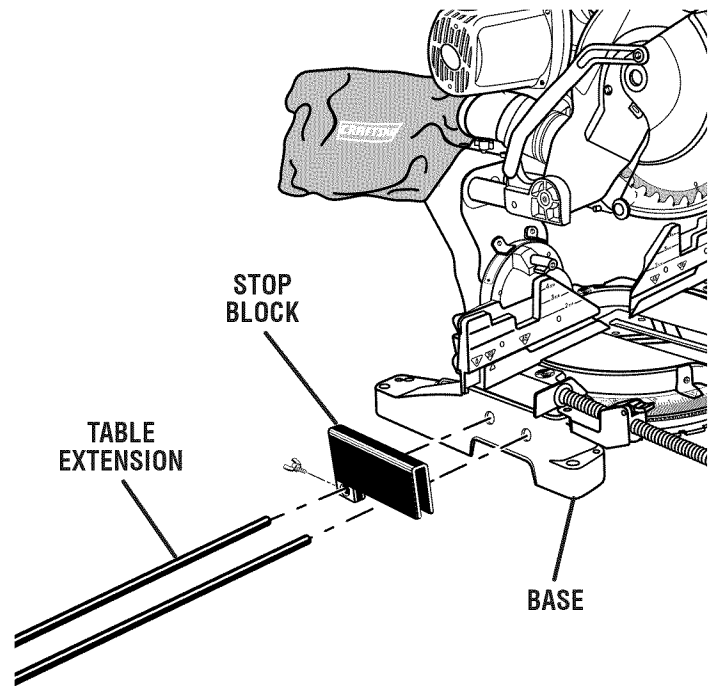

Fig. 15

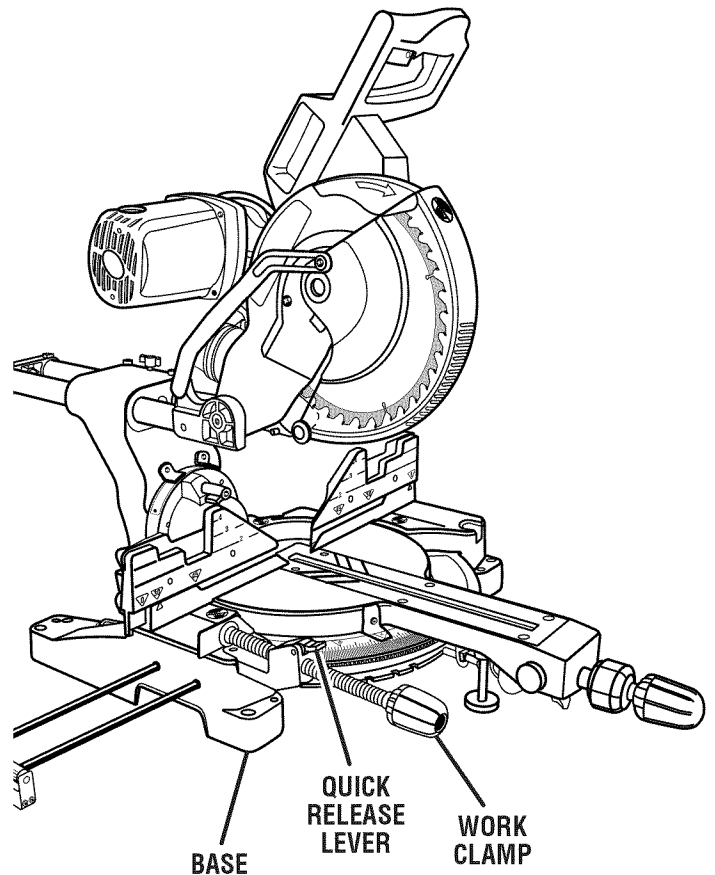

Fig. 16

# ASSEMBLY

- Unplug the saw.
- Loosen the phillips screw on the blade bolt cover until the cover can be raised.
- Gently raise the lower blade guard bracket so that lower blade guard and blade bolt cover can be rotated up and back to expose the blade bolt.
- Depress the spindle lock button and rotate the blade bolt until the spindle locks.
- Using the blade wrench provided, loosen and remove laser screw or blade bolt.

**NOTE: BEFORE USE, REPLACE SCREW AND TIGHTEN SECURELY TO PREVENT GUARD MOVEMENT**

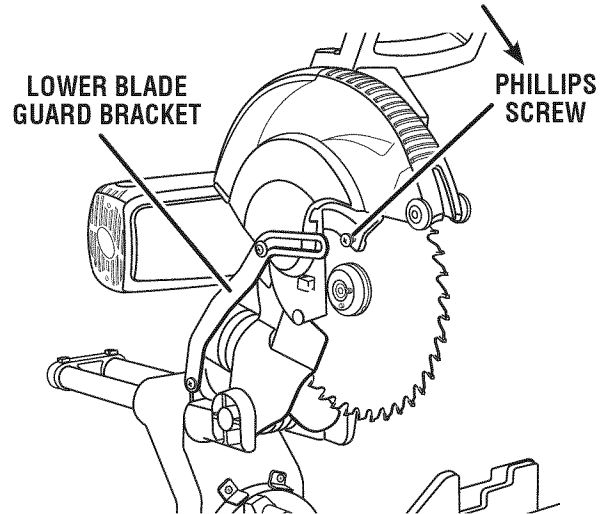

Fig. 17

**⚠ WARNING:** If the inner blade washer has been removed, replace it before placing the blade on the spindle. Failure to do so could cause an accident since the blade will not tighten properly.

- Fit the saw blade inside the upper blade guard and onto the spindle. The blade teeth point downward at the front of saw as shown in figure 17.

**⚠ CAUTION:** Always install the blade with the blade teeth and the arrow printed on the side of the blade pointing down at the front of the saw. The direction of blade rotation is also stamped with an arrow on the upper blade guard.

- Replace the laser guide or outer blade washer (see instructions on the following page). The double “D” flats align with the flats on the spindle.
  - Depress spindle lock button and replace blade bolt.
- NOTE:** The laser screw (blade bolt) has left hand threads. Turn blade bolt counterclockwise to tighten.
- Tighten blade bolt securely.
  - Replace the lower blade guard and blade bolt cover.
  - Retighten the phillips screw securing the blade bolt cover.

**⚠ CAUTION:** Make sure the spindle lock button is not engaged before reconnecting saw to power source. Never engage spindle lock button when blade is rotating.

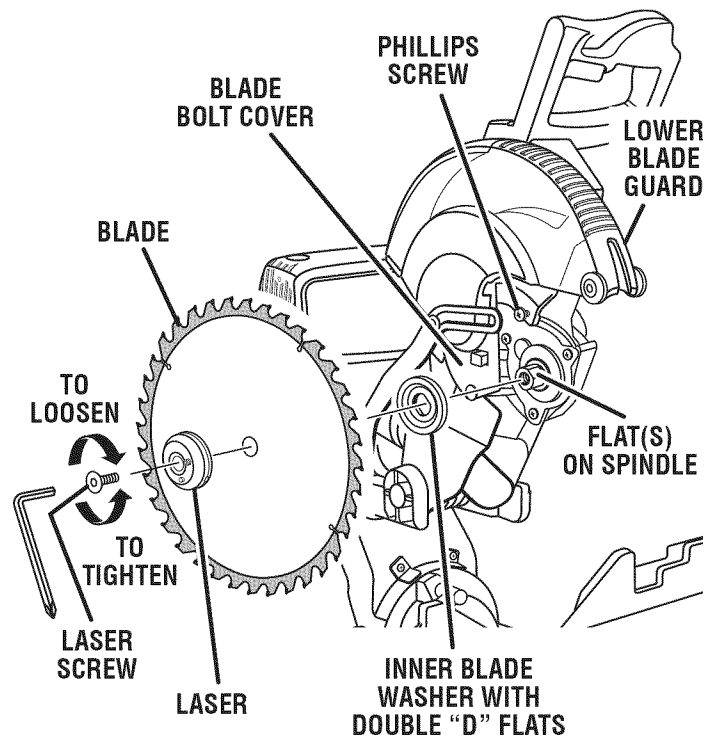

Fig. 18

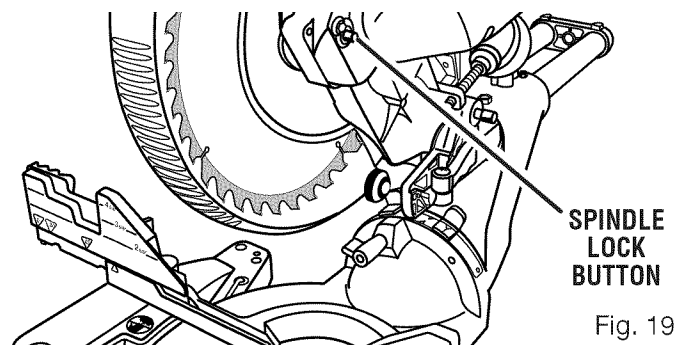

Fig. 19

# ASSEMBLY

**⚠ DANGER:** Laser radiation. Avoid direct eye contact with light source.

## ALIGNING THE LASER GUIDE LINE

See Figure 20.

The laser guide will generate a laser line on the work surface when the saw blade is spinning. The laser line will appear as a broken line on the workpiece when the saw arm is in the uppermost position and the motor switch is activated. This broken line will let you see your mark and your laser guide line at the same time, and will assist you in lining up your mark for more accurate cutting of the workpiece.

Align the laser line and your mark with the blade at the uppermost position. Once both lines are in alignment, do not move the workpiece until after you have finished cutting.

As the blade assembly is lowered toward the workpiece, the broken line will become solid.

Follow the directions below for using the laser guide:

### Removing the mark:

Position the laser line on the left edge of your mark on the work surface in order to remove the mark.

### To cut the mark:

Position the laser line near or over your mark on the work surface in order to cut the mark.

### To leave the mark:

Position the laser line near the right edge of your mark on the work surface in order to leave the mark.

After you have become familiar with using the laser guide, you will be able to remove, cut, or leave your mark on the work surface. Practice will teach you the correct position for aligning the laser line with your mark.

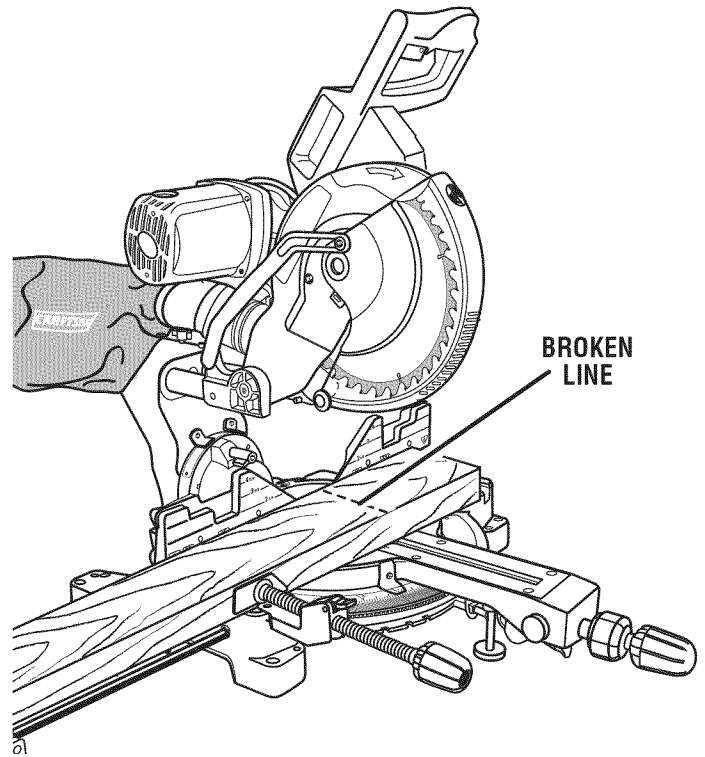

Fig. 20

# ASSEMBLY

## REMOVING / REPLACING THE THROAT PLATE

See Figure 21.

- Unplug the saw.
- Using the blade wrench provided, loosen the screws securing the throat plate.
- Lift the throat plate from the saw base.
- To reinstall the throat plate, align the holes in the throat plate with the holes in the saw base.
- Retighten the screws, being careful not to overtighten which can cause the throat plate to bow or bend.

## CENTERING THE SAW BLADE BETWEEN THE SLIDE BARS

See Figure 22.

The saw blade should be centered (approximately) between the two pieces of the throat plate and there should be no play between the right slide bar and the pivot assembly. Standing in front of the saw, make a visual inspection. If adjustment is required:

- Unplug the saw.
- With the miter at 0° and the bevel at 0°, lock the saw into the transport position.
- Loosen the jam nut on the top and bottom gib screws as shown.
- Loosen the top gib screws.
- Tighten or loosen the lower gib screw as required to center the blade between the two pieces of the throat plate.
- Once centered, tighten the lower two jam nuts.

**NOTE:** To minimize play in the slide bars, gradually tighten the two top gib screws while sliding the saw back and forth over the slide bars. Tighten the top jam nuts.

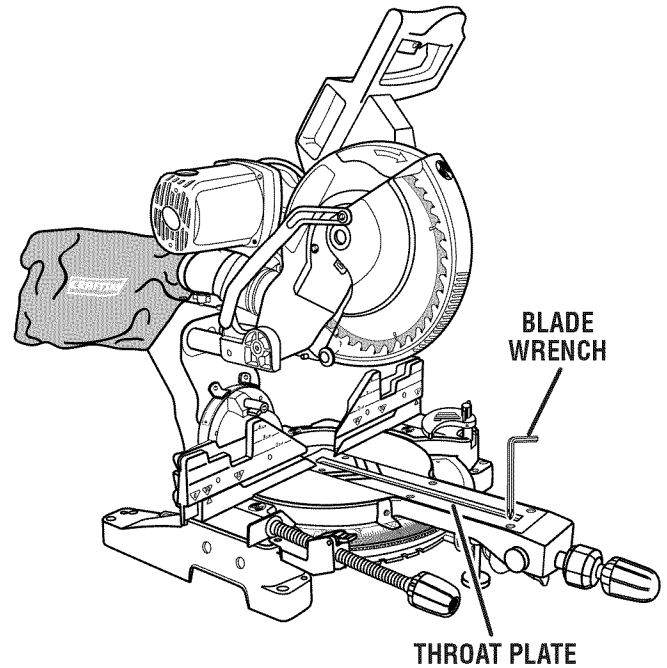

Fig. 21

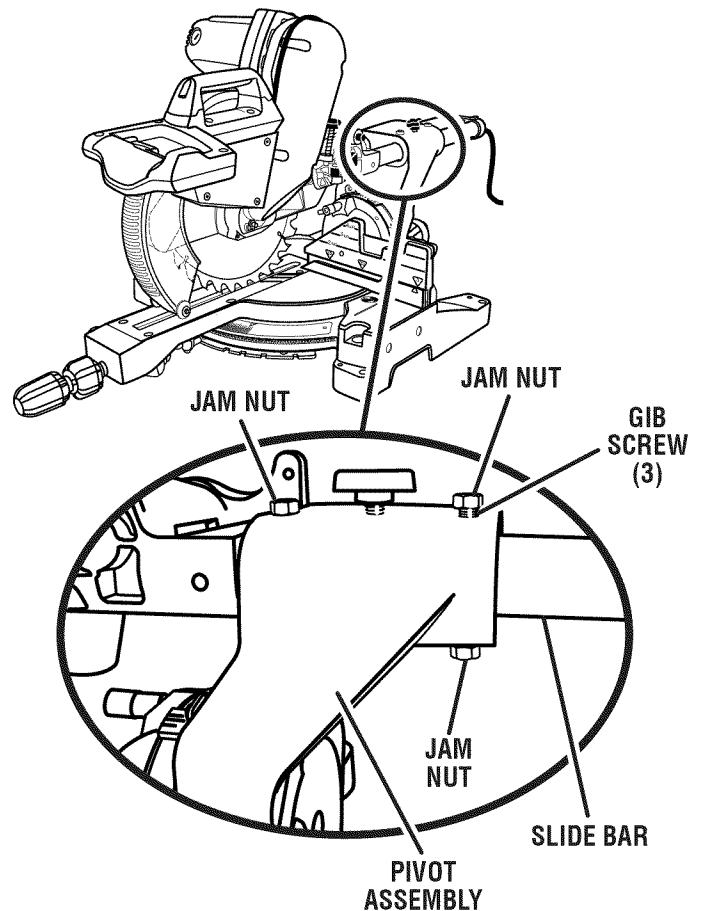

Fig. 22

# ASSEMBLY

## SQUARING THE SAW BLADE TO THE FENCE

See Figures 23 - 27.

- Unplug the saw.
- Pull the saw arm all the way down and engage the lock pin to hold the saw arm in transport position.
- Loosen the miter lock handle.
- Rotate the miter table until the pointer is positioned at 0°.
- Retighten the miter lock handle.
- Lay a framing square flat on the miter table. Place one leg of the square against the fence. Slide the other leg of the square against the flat part of blade.

**NOTE:** Make sure that the square contacts the flat part of the blade, not the blade teeth.

- The edge of the square and the blade should be parallel as shown in figure 24.
- If the front or back edge of the blade angles away from the square as shown in figures 25 and 26, adjustments are needed.
- Using a 6 mm wrench, loosen the hex screws that secure the mounting bracket to the miter table.
- Rotate the mounting bracket left or right until the blade is parallel with the square.
- Retighten the screws securely and recheck the blade-to-fence alignment.

The saw has several scale indicators. After squaring adjustments have been made, it may be necessary to loosen the indicator screws and reset them to zero. See Figure 27.

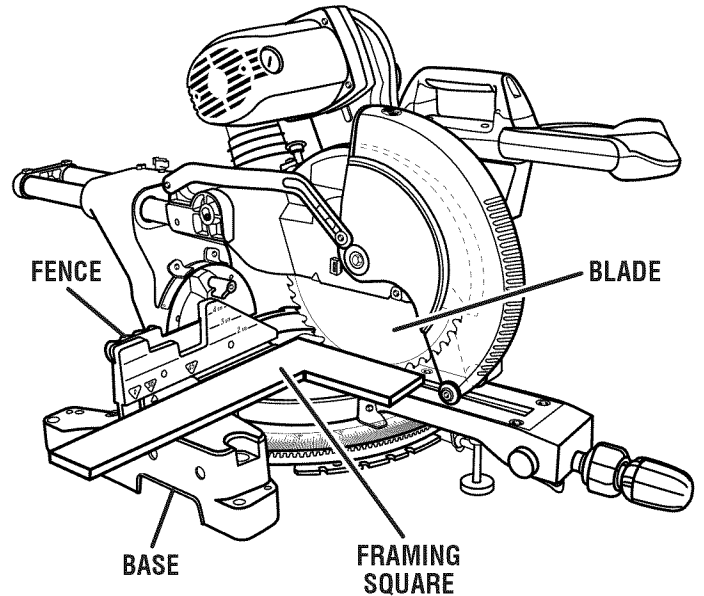

Fig. 24

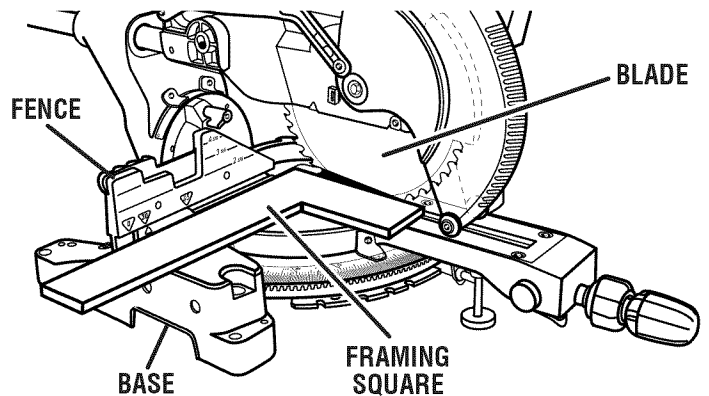

Fig. 25

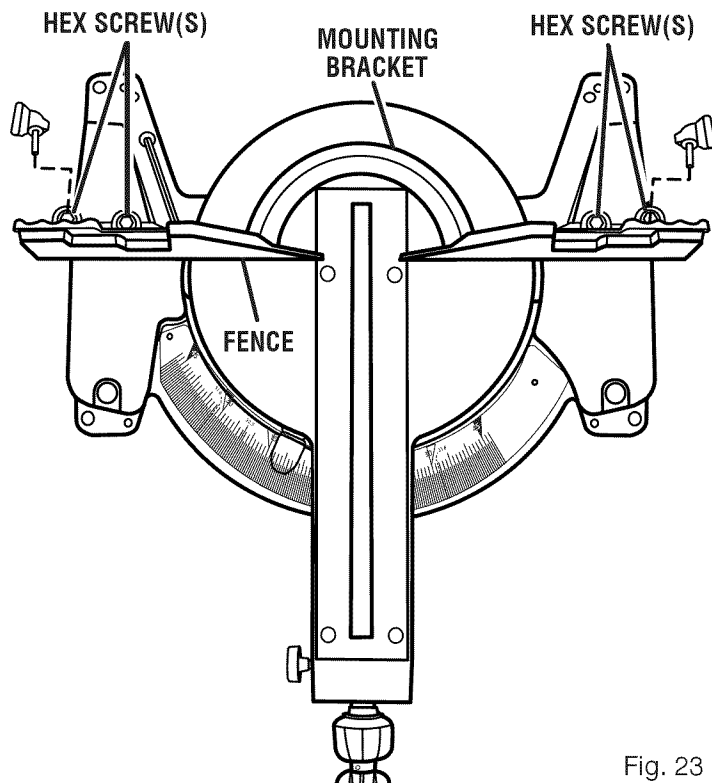

Fig. 23

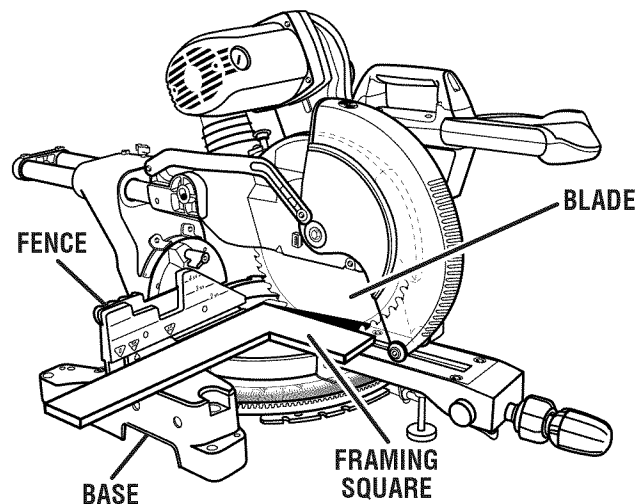

Fig. 26

VIEW OF BLADE NOT SQUARE WITH FENCE, ADJUSTMENTS ARE REQUIRED

# ASSEMBLY

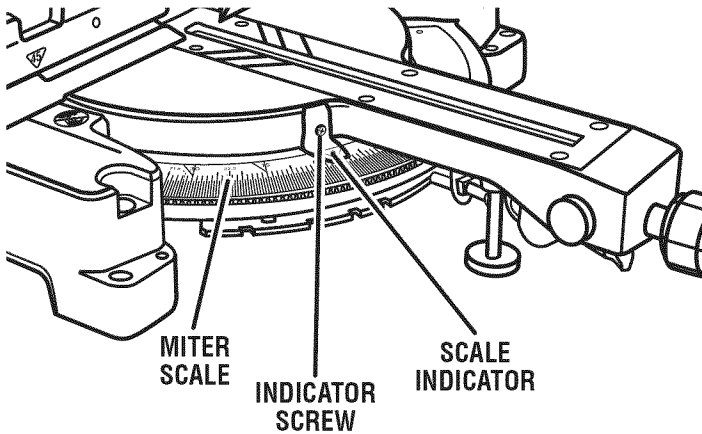

Fig. 27

## ADJUSTING THE BEVEL PIVOT

See Figure 28.

The saw should freely pivot when the bevel lock knob is “unlocked” and the saw is beveled. A “grating” sound indicates that the bevel needs to be loosened slightly. If the movement is tight or there is play in the pivot, an adjustment is required.

### To adjust:

- Unplug the saw.
- Loosen the bevel lock knob.
- Using the 8 mm hex key provided, turn the socket head cap screw clockwise to tighten or counterclockwise to loosen.
- Once all adjustments have been made, securely tighten the bevel lock knob.

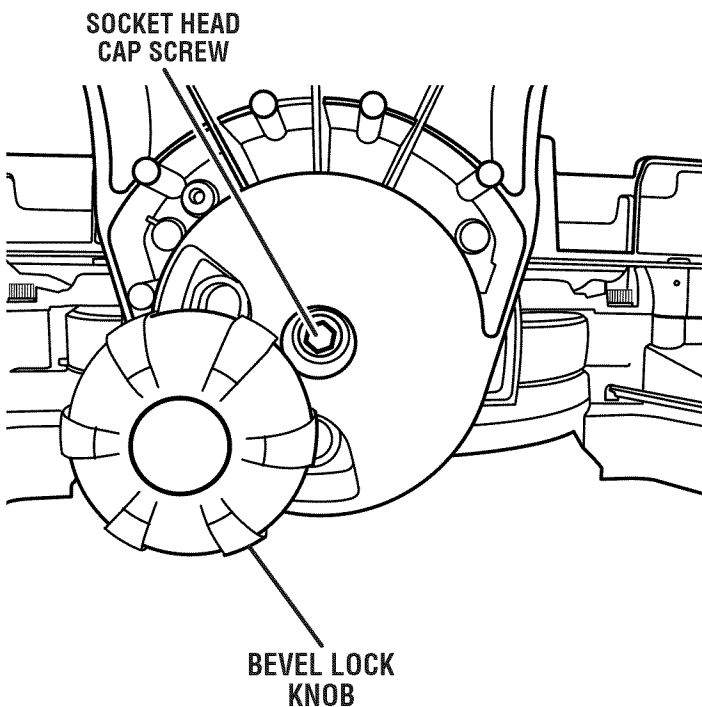
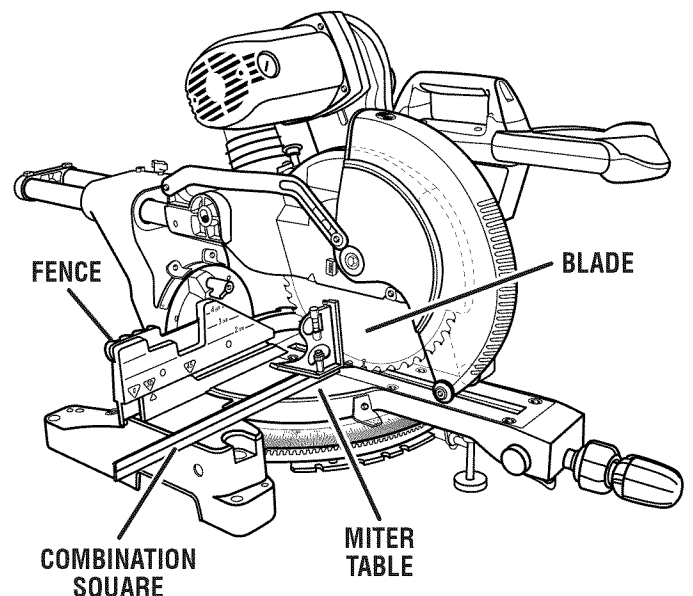

Fig. 28

## SQUARING THE BLADE TO THE MITER TABLE

See Figures 29 - 31.

- Unplug the saw.
  - Pull the saw arm all the way down and engage the lock pin to hold the saw arm in transport position.
  - Loosen the miter lock handle.
  - Rotate the miter table until the pointer is positioned at 0°.
  - Securely tighten the miter lock handle.
  - Loosen bevel lock knob and set saw arm at 0° bevel (blade set 90° to miter table). Tighten bevel lock knob.
  - Place a combination square against the miter table and the flat part of saw blade.
- NOTE:** Make sure that the square contacts the flat part of the saw blade, not the blade teeth.
- Rotate the blade by hand and check the blade-to-table alignment at several points.
  - The edge of the square and the blade should be parallel.
  - If the top or bottom of the blade angles away from the square as shown in figures 30 and 31, adjustments are needed.
  - Loosen the jam nut on the top and bottom gib screws. See Figure 22.
  - Loosen the top gib screws.
  - Tighten or loosen the lower gib screws as required to square the blade to the table.
  - Once blade is square with table, tighten the lower two jam nuts.



CORRECT VIEW OF BLADE SQUARE WITH MITER TABLE

Fig. 29

# ASSEMBLY

**NOTE:** To minimize play in the slide bars, gradually tighten the two top gib screws while sliding the saw back and forth over the slide bars. Tighten the top jam nuts.

- Retighten bevel lock knob.

**NOTE:** The above procedure can be used to check squareness of the blade to the miter table at both 0° and 45° angles.

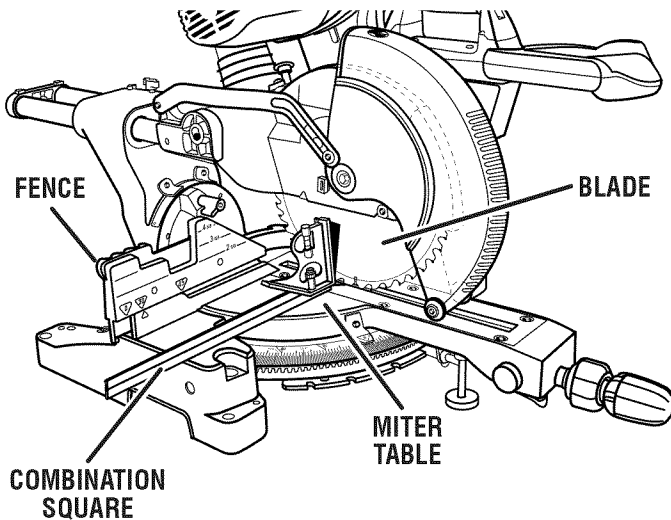

VIEW OF BLADE NOT SQUARE WITH MITER TABLE, ADJUSTMENTS ARE REQUIRED

Fig. 30

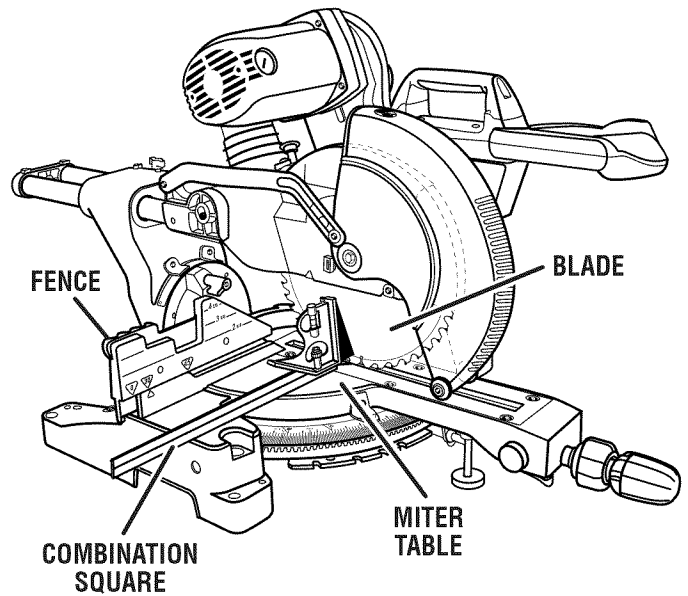

VIEW OF BLADE NOT SQUARE WITH MITER TABLE, ADJUSTMENTS ARE REQUIRED

Fig. 31

# OPERATION

**WARNING:** Do not allow familiarity with tools to make you careless. Remember that a careless fraction of a second is sufficient to inflict severe injury.

**WARNING:** Always wear safety goggles or safety glasses with side shields when operating tools. Failure to do so could result in objects being thrown into your eyes resulting in possible serious injury.

**WARNING:** Do not use any attachments or accessories not recommended by the manufacturer of this tool. The use of attachments or accessories not recommended can result in serious personal injury.

**CAUTION:** Do not start the compound miter saw without checking for interference between the blade and the throat plate. Damage could result to the throat plate if the blade strikes it during operation of the saw.

**WARNING:** Before starting any cutting operation, clamp or bolt the compound miter saw to a workbench. Never operate the miter saw on the floor or in a crouched position. Failure to heed this warning can result in serious personal injury.

**WARNING:** To avoid serious personal injury, keep your hands outside the no hands zone, at least 3 in. from blade. Never perform any cutting operation freehand (without holding workpiece against the fence). The blade could grab the workpiece if it slips or twists.

**CAUTION:** Do not start the compound miter saw without checking for interference between the blade and the miter fence. Damage could result to the blade if it strikes the miter fence during operation of the saw.

# OPERATION

## APPLICATIONS

You may use this tool to cut only wood or plastic as listed below:

- Cross cutting miters, joints, etc., for picture frames, moldings, door casings, and fine joinery.
- Bevel and compound cutting
- Cross cutting wide workpieces

**NOTE:** The blade provided is fine for most wood cutting operations, but for fine joinery cuts or cutting plastic, use one of the accessory blades available from your nearest Sears retail store.

## CUTTING WITH YOUR SLIDING COMPOUND MITER SAW

**⚠ WARNING:** When using a work clamp or C-clamp to secure the workpiece, clamp workpiece on one side of the blade only. The workpiece must remain free on one side of the blade to prevent the blade from binding in workpiece. The workpiece binding the blade will cause motor stalling and kickback. This situation could cause an accident resulting in possible serious personal injury.

**⚠ WARNING:** To avoid serious personal injury, always tighten the miter lock handle and the bevel lock knob securely before making a cut. Failure to do so could result in movement of the control arm or miter table while making a cut.

**⚠ WARNING:** Do not try to cut narrow pieces using the sliding feature. Failure to heed this warning could result in serious personal injury.

**⚠ WARNING:** Never make a cut by pulling the saw toward you as the blade can climb on top of the workpiece and come toward you. Failure to heed this warning could result in serious personal injury.

## TO SLIDE CUT

See Figures 32 - 33.

The sliding feature will cut workpieces 11-1/2 in. wide by 3-1/2 in. thick. With the saw off, pull the saw arm forward. Turn the saw on (let blade reach maximum speed), then push the blade down on top of the workpiece then back toward the rear of the saw to make a cut. Cuts are made by: pushing the saw blade away from you and toward the bevel scale at the back of the saw stopping when the full rear position has been reached after each cut. When the saw is running (turned on), **NEVER** pull the saw blade toward you or toward the front of the saw.

- Raise saw arm to its full height.
- Place the workpiece flat on the miter table with one edge securely against the fence. If the board is warped, place the convex side against the fence. If the concave edge of a board is placed against the fence, the board

## SLIDE CUT

SLIDE SAW ARM  
FORWARD THEN  
PUSH DOWN

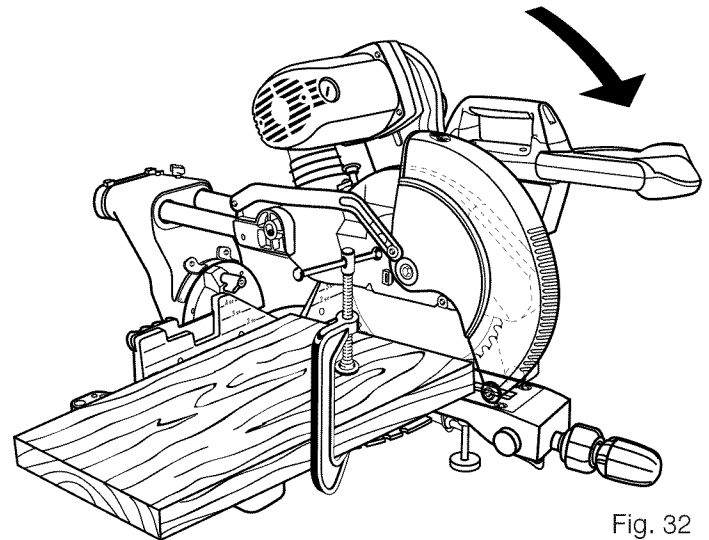

Fig. 32

could collapse on the blade at the end of the cut, jamming the blade. See Figures 46 - 47.

- When cutting long pieces of lumber or molding, support the opposite end of the stock with a roller stand or with a work surface level with the saw table. See Figure 41.
- Align the cutting line on the workpiece with the edge of saw blade.
- Loosen the slide lock knob by turning the knob counterclockwise.
- Grasp the stock firmly with one hand and secure it against the fence. Use the work clamp or a C-clamp to secure the workpiece when possible.
- Before turning on the saw, perform a dry run of the cutting operation to make sure that no problems will occur when the cut is made.

PUSH  
BACK

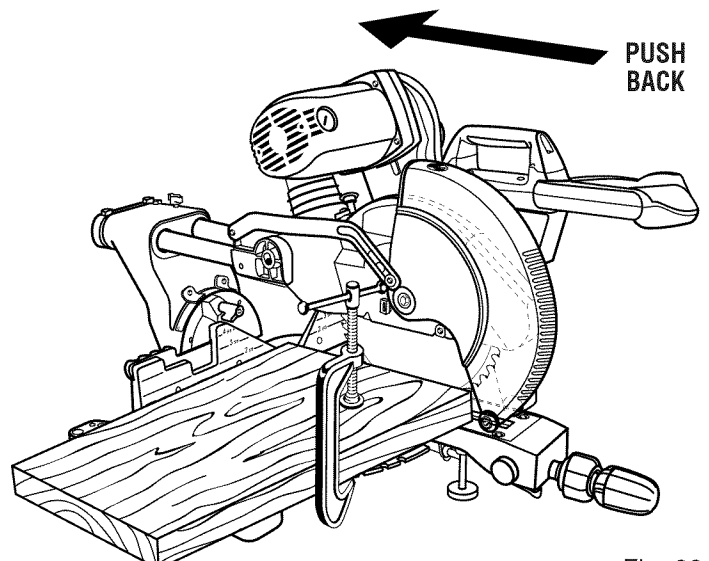

Fig. 33

# OPERATION

- With the saw off, grasp the saw handle firmly then pull the saw forward until the blade arbor (center of the saw blade) is over the front of the workpiece.
- Depress the switch lock with thumb then squeeze the switch trigger. Allow several seconds for the blade to reach maximum speed.
- Slowly lower the blade into and through the front edge of the workpiece.
- Push the saw handle away from you and toward the bevel scale at the back of the saw.
- Release the switch trigger and allow the saw blade to stop rotating before raising the blade out of the workpiece and removing the workpiece from miter table.

**NOTE:** A cross cut is made by cutting across the grain of the workpiece. A straight cross cut is made with the miter table set at the 0° position. Miter cross cuts are made with the miter table set at some angle other than 0°.

## TO MAKE NON-SLIDING CUTS

**⚠ WARNING:** Securely tighten the slide lock knob when making any non-sliding cuts. Failure to tighten the knob could result in the saw head moving during the cutting operation.

## TO MITER CUT / CROSS CUT

See Figures 34 - 35.

A cross cut is made by cutting across the grain of the workpiece. A straight cross cut is made with the miter table set at the 0° position. Miter cross cuts are made with the miter table set at some angle other than zero.

- Make sure the slide lock knob is tightened securely.
- Pull out the lock pin and lift saw arm to its full height.
- Loosen the miter lock handle.
- Lift the miter lock plate to disengage.
- Rotate the miter table until the pointer aligns with the desired angle on the miter scale.
- Release the miter lock plate.

**NOTE:** You can quickly locate 0°, 15°, 22.5°, 31.6°, and 45° left or right by releasing the lock plate as you rotate the control arm. The lock plate will seat itself in one of the positive stop notches, located in the base.

- Tighten the miter lock handle securely.
- Place the workpiece flat on the miter table with one edge securely against the fence. If the board is warped, place the convex side against the fence. If the concave edge of a board is placed against the fence, the board could collapse on the blade at the end of the cut, jamming the blade.
- When cutting long pieces of lumber or molding, support the opposite end of the stock with a roller stand or with a work surface level with the saw table. See Figure 41.

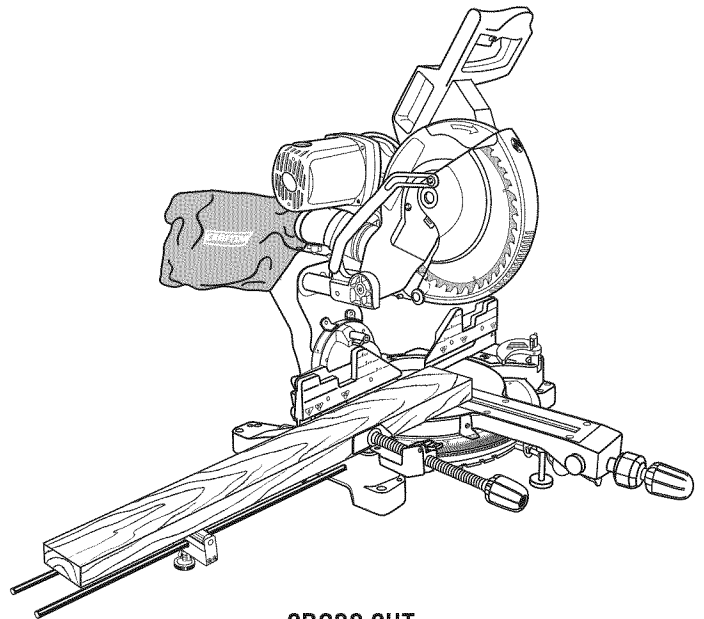

CROSS CUT

Fig. 34

- Align cutting line on the workpiece with the edge of blade.
- Grasp the stock firmly with one hand and secure it against the fence or use the work clamp or a C-clamp to secure the workpiece.
- Before turning on the saw, perform a dry run of the cutting operation just to make sure that no problems will occur when the cut is made.

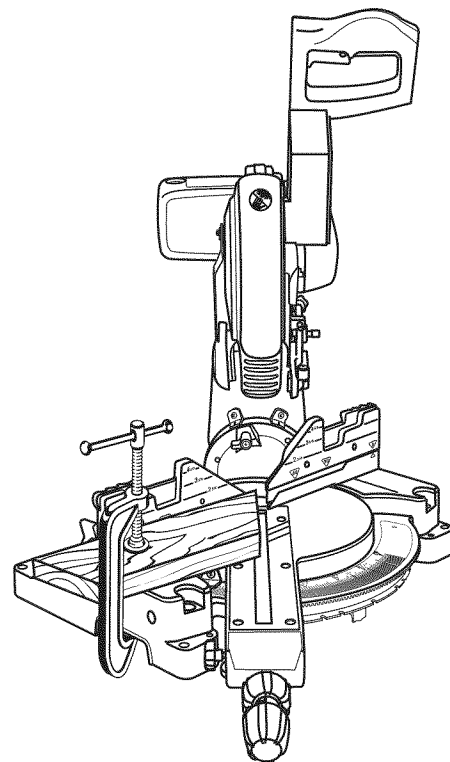

MITER CUT

Fig. 35

# OPERATION

- Grasp the saw handle firmly then squeeze the switch trigger. Allow several seconds for the blade to reach maximum speed.
- Slowly lower the blade into and through the workpiece.
- Release the switch trigger and allow the blade to stop rotating before raising the blade out of the workpiece. Wait until the electric brake stops blade from turning before removing the workpiece from the miter table.

## TO BEVEL CUT

See Figures 36 - 38.

A bevel cut is made by cutting across the grain of the workpiece with the blade angled to the workpiece. A straight bevel cut is made with the miter table set at the zero degree position and the blade set at an angle between 0° and 45°.

- Unplug the saw.
  - Pull out the lock pin and lift saw arm to its full height.
  - Loosen the miter lock handle.
  - Lift the miter lock plate to disengage.
  - Rotate the miter table until the pointer aligns with zero on the miter scale.
  - Release the miter lock plate.
- NOTE:** You can quickly locate zero by releasing the lock plate as you rotate the control arm. The lock plate will seat itself in one of the built-in positive stop notches, located in the base.
- Tighten the miter lock handle securely.
  - Adjustments of the miter fence must be made to correspond to the desired angle of the bevel cut **prior to tilting the saw arm**. The fence is marked for 0°, 15°, 30°, or 45°. Loosen the fence screw on the miter fence, slide the fence to the desired position, and retighten the fence screw.
  - The 45° triangle on the miter fence provides for the maximum clearance required for adjusting the miter saw's angle when making a bevel or compound cut.

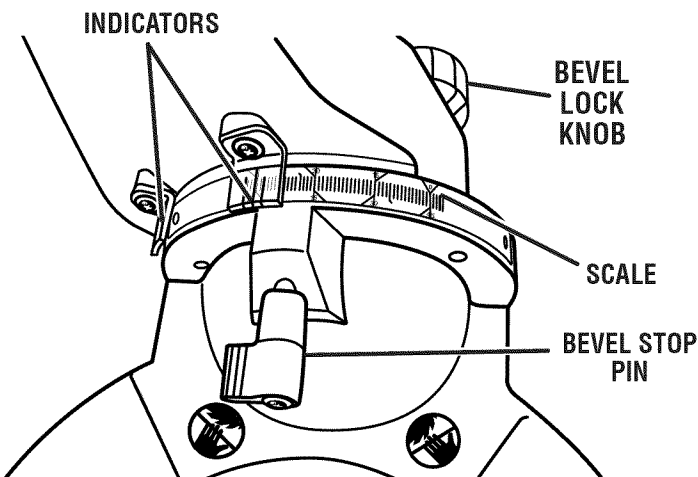
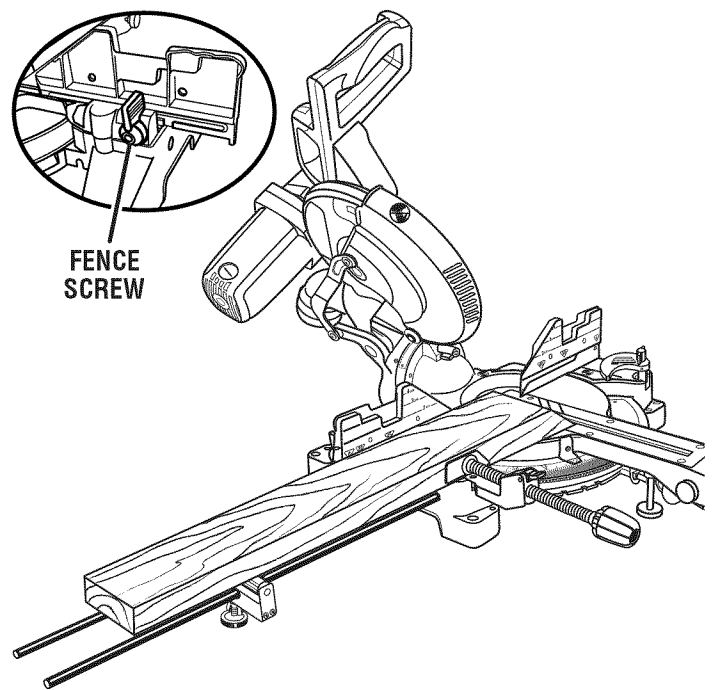

Fig. 36

- Loosen the bevel lock knob and move the saw arm to the left or right to the desired bevel angle.
- NOTE:** The bevel stop pin has two positions: 1) override (pin pulled completely out), and 2) the 0° - 48° position for crown molding (pin pushed in).
- Bevel angles can be set from 0° to 45°.
  - Align the indicator point for the desired angle.
  - Once the saw arm has been set at the desired angle, securely tighten the bevel lock knob.
  - Place the workpiece flat on the miter table with one edge securely against the fence. If the board is warped, place the convex side against the fence. If the concave edge of a board is placed against the fence, the board could collapse on the blade at the end of the cut, jamming the blade.
  - When cutting long pieces of lumber or molding, support the opposite end of the stock with a roller stand or with a work surface level with the saw table.
  - Align the cutting line on the workpiece with the edge of saw blade.
  - Grasp the stock firmly with one hand and secure it against the fence or use the work clamp or a C-clamp to secure the workpiece.
  - Plug the saw into the power source. Before turning on the saw, perform a dry run of the cutting operation just to make sure that no problems will occur when the cut is made.
  - Grasp the saw handle firmly then squeeze the switch trigger. Allow several seconds for the blade to reach maximum speed.
  - Slowly lower the blade into and through the workpiece.



BEVEL CUT

Fig. 37

# OPERATION

- Release the switch trigger and allow the saw blade to stop rotating before raising the blade out of the workpiece. Wait until the electric brake stops blade from turning before removing the workpiece from miter table.

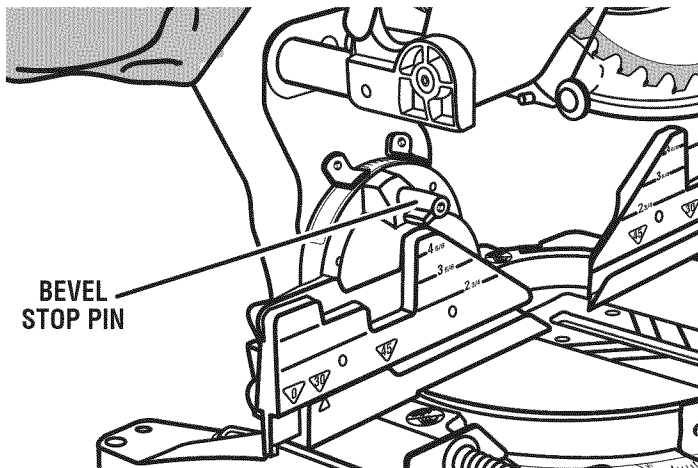

Fig. 38

## TO COMPOUND MITER CUT

A compound miter cut is a cut made using a miter angle and a bevel angle at the same time. This type of cut is used to make picture frames, cut molding, make boxes with sloping sides, and for certain roof framing cuts.

To make this type of cut the control arm on the miter table must be rotated to the correct angle and the saw arm must be tilted to the correct bevel angle. Care should always be taken when making compound miter setups due to the interaction of the two angle settings.

Adjustments of miter and bevel settings are interdependent with one another. Each time you adjust the miter setting you change the effect of the bevel setting. Also, each time you adjust the bevel setting you change the effect of the miter setting.

It may take several settings to obtain the desired cut. The first angle setting should be checked after setting the second angle, since adjusting the second angle affects the first.

Once the two correct settings for a particular cut have been obtained, always make a test cut in scrap material before making a finish cut in good material.

- Pull out the lock pin and lift saw arm to its full height.
- Loosen the miter lock handle.
- Lift the miter lock plate to disengage.
- Rotate the miter table until the pointer aligns with the desired angle on the miter scale.
- Release the miter lock plate.

**NOTE:** You can quickly locate 0°, 15°, 22.5°, 31.6°, and 45° left or right by releasing the miter lock plate as you rotate the control arm. The miter lock plate will seat itself in one of the positive stop notches, located in the base.

- Retighten the miter lock handle securely.
- Adjustments of the miter fence must be made to correspond to the desired angle of the bevel cut **prior to tilting the saw arm**. The fence is marked for 0°, 15°, 30°, or 45°. Loosen the fence screw on the miter fence, slide the fence to the desired position, and retighten the fence screw.
- The 45° triangle on the miter fence provides for the maximum clearance required for adjusting the miter saw's angle when making a bevel or compound cut.
- Loosen the bevel lock knob and move the saw arm to the left or right to the desired bevel angle.
- Bevel angles can be set from 0° to 45°.
- Once the saw arm has been set at the desired angle, securely tighten the bevel lock knob.
- Recheck miter angle setting. Make a test cut in scrap material.
- Place the workpiece flat on the miter table with one edge securely against the fence. If the board is warped, place the convex side against the fence. If the concave edge of a board is placed against the fence, the board could collapse on the blade at the end of the cut, jamming the blade.
- When cutting long pieces of lumber or molding, support the opposite end of the stock with a roller stand or with a work surface level with the saw table.
- Align the cutting line on the workpiece with the edge of saw blade.
- Grasp the stock firmly with one hand and secure it against the fence or use the work clamp or a C-clamp to secure the workpiece when possible.

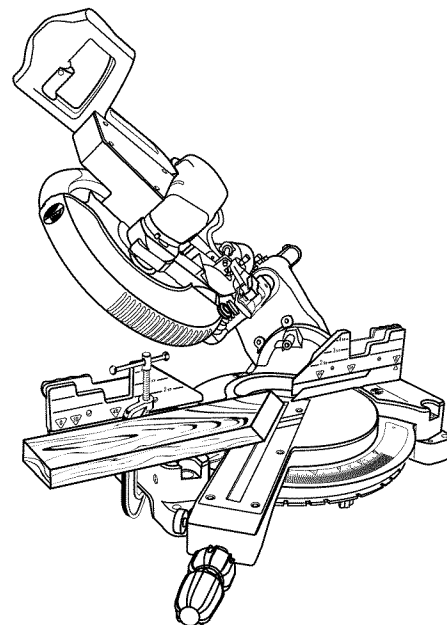

COMPOUND MITER CUT

Fig. 39

# OPERATION

- Before turning on the saw, perform a dry run of the cutting operation just to make sure that no problems will occur when the cut is made.
- Grasp the saw handle firmly then squeeze the switch trigger. Allow several seconds for the blade to reach maximum speed.
- Slowly lower the blade into and through the workpiece.
- Release the switch trigger and allow the blade to stop rotating before raising the blade out of the workpiece. Wait until the electric brake stops blade from turning before removing the workpiece from miter table.

## SUPPORT LONG WORKPIECES

See Figure 38.

Long workpieces need extra supports. Supports should be placed along the workpiece so it does not sag. The support should let the workpiece lay flat on the base of the saw and work table during the cutting operation. Use the work clamp or a C-clamp to secure the workpiece.

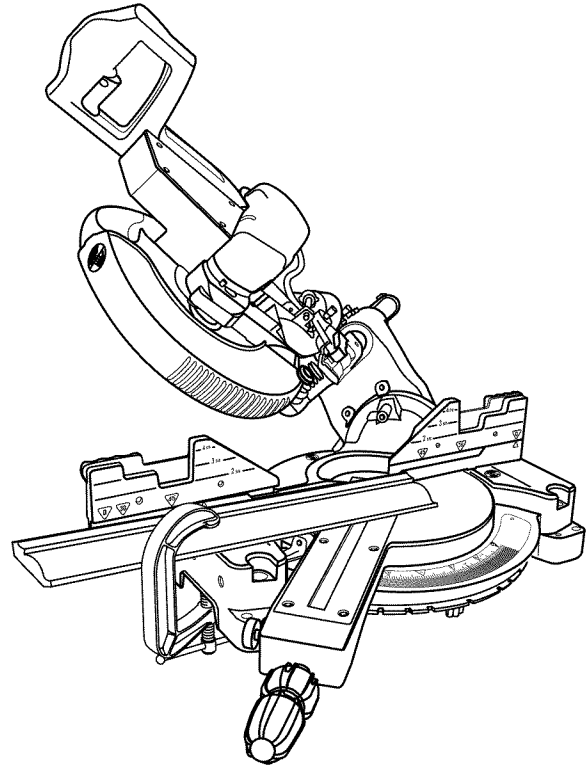

45° X 45° COMPOUND MITER CUT

Fig. 40

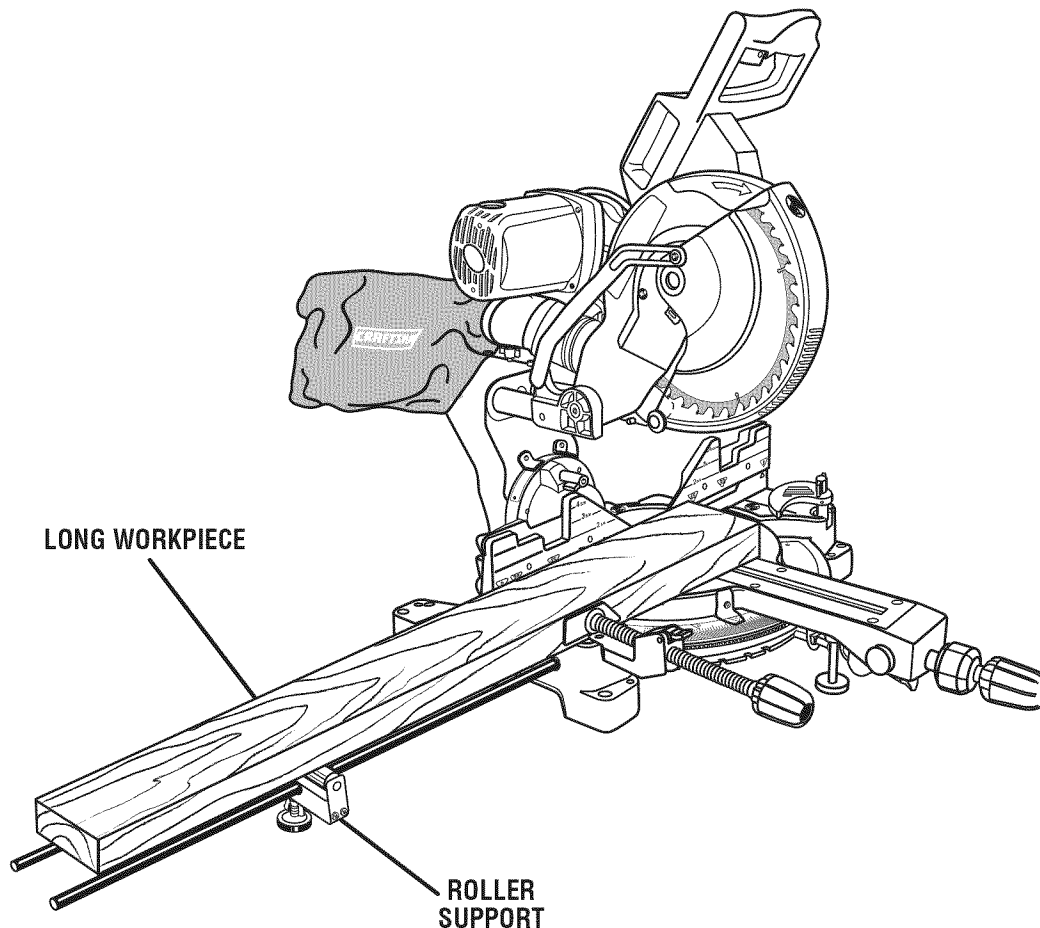

Fig. 41

# OPERATION

## CUTTING COMPOUND MITERS

To aid in making the correct settings, the compound angle setting chart below has been provided. Since compound cuts are the most difficult to accurately obtain, trial cuts should be made in scrap material, and much thought and planning made, prior to making your required cut.

PITCH OF SIDE	NUMBER OF SIDES						
	4	5	6	7	8	9	10
0°	M- 45.00° B- 0.00°	M- 36.00° B- 0.00°	M- 30.00° B- 0.00°	M- 25.71° B- 0.00°	M- 22.50° B- 0.00°	M- 20.00° B- 0.00°	M- 18.00° B- 0.00°
5°	M- 44.89° B- 3.53°	M- 35.90° B- 2.94°	M- 29.91° B- 2.50°	M- 25.63° B- 2.17°	M- 22.42° B- 1.91°	M- 19.93° B- 1.71°	M- 17.94° B- 1.54°
10°	M- 44.56° B- 7.05°	M- 35.58° B- 5.86°	M- 29.62° B- 4.98°	M- 25.37° B- 4.32°	M- 22.19° B- 3.81°	M- 19.72° B- 3.40°	M- 17.74° B- 3.08°
15°	M- 44.01° B- 10.55°	M- 35.06° B- 8.75°	M- 29.15° B- 7.44°	M- 24.95° B- 6.45°	M- 21.81° B- 5.68°	M- 19.37° B- 5.08°	M- 17.42° B- 4.59°
20°	M- 43.22° B- 14.00°	M- 34.32° B- 11.60°	M- 28.48° B- 9.85°	M- 24.35° B- 8.53°	M- 21.27° B- 7.52°	M- 18.88° B- 6.72°	M- 16.98° B- 6.07°
25°	M- 42.19° B- 17.39°	M- 33.36° B- 14.38°	M- 27.62° B- 12.20°	M- 23.56° B- 10.57°	M- 20.58° B- 9.31°	M- 18.26° B- 8.31°	M- 16.41° B- 7.50°
30°	M- 40.89° B- 20.70°	M- 32.18° B- 17.09°	M- 26.57° B- 14.48°	M- 22.64° B- 12.53°	M- 19.73° B- 11.03°	M- 17.50° B- 9.85°	M- 15.72° B- 8.89°
35°	M- 39.32° B- 23.93°	M- 30.76° B- 19.70°	M- 25.31° B- 16.67°	M- 21.53° B- 14.41°	M- 18.74° B- 12.68°	M- 16.60° B- 11.31°	M- 14.90° B- 10.21°
40°	M- 37.45° B- 27.03°	M- 29.10° B- 22.20°	M- 23.86° B- 18.75°	M- 20.25° B- 16.19°	M- 17.60° B- 14.24°	M- 15.58° B- 12.70°	M- 13.98° B- 11.46°
45°	M- 35.26° B- 30.00°	M- 27.19° B- 24.56°	M- 22.21° B- 20.70°	M- 18.80° B- 17.87°	M- 16.32° B- 15.70°	M- 14.43° B- 14.00°	M- 12.94° B- 12.62°
50°	M- 32.73° B- 32.80°	M- 25.03° B- 26.76°	M- 20.36° B- 22.52°	M- 17.20° B- 19.41°	M- 14.91° B- 17.05°	M- 13.17° B- 15.19°	M- 11.80° B- 13.69°
55°	M- 29.84° B- 35.40°	M- 22.62° B- 28.78°	M- 18.32° B- 24.18°	M- 15.44° B- 20.82°	M- 13.36° B- 18.27°	M- 11.79° B- 16.27°	M- 10.56° B- 14.66°
60°	M- 26.57° B- 37.76°	M- 19.96° B- 30.60°	M- 16.10° B- 25.66°	M- 13.54° B- 22.07°	M- 11.70° B- 19.35°	M- 10.31° B- 17.23°	M- 9.23° B- 15.52°
65°	M- 22.91° B- 39.86°	M- 17.07° B- 32.19°	M- 13.71° B- 26.95°	M- 11.50° B- 23.16°	M- 9.93° B- 20.29°	M- 8.74° B- 18.06°	M- 7.82° B- 16.26°
70°	M- 18.88° B- 41.64°	M- 13.95° B- 33.53°	M- 11.17° B- 28.02°	M- 9.35° B- 24.06°	M- 8.06° B- 21.08°	M- 7.10° B- 18.75°	M- 6.34° B- 16.88°
75°	M- 14.51° B- 43.08°	M- 10.65° B- 34.59°	M- 8.50° B- 28.88°	M- 7.10° B- 24.78°	M- 6.12° B- 21.69°	M- 5.38° B- 19.29°	M- 4.81° B- 17.37°
80°	M- 9.85° B- 44.14°	M- 7.19° B- 35.37°	M- 5.73° B- 29.50°	M- 4.78° B- 25.30°	M- 4.11° B- 22.14°	M- 3.62° B- 19.68°	M- 3.23° B- 17.72°
85°	M- 4.98° B- 44.78°	M- 3.62° B- 35.84°	M- 2.88° B- 29.87°	M- 2.40° B- 25.61°	M- 2.07° B- 22.41°	M- 1.82° B- 19.92°	M- 1.62° B- 17.93°
90°	M- 0.00° B- 45.00°	M- 0.00° B- 36.00°	M- 0.00° B- 30.00°	M- 0.00° B- 25.71°	M- 0.00° B- 22.50°	M- 0.00° B- 20.00°	M- 0.00° B- 18.00°

Each B (Bevel) and M (Miter) Setting is Given to the Closest 0.005°.

### COMPOUND-ANGLE SETTINGS FOR POPULAR STRUCTURES

# OPERATION

## CUTTING CROWN MOLDING

The compound miter saw does an excellent job of cutting crown molding. In general, compound miter saws do a better job of cutting crown molding than any other tool made.

In order to fit properly, crown molding must be compound mitered with extreme accuracy.

The two contact surfaces on a piece of crown molding that fit flat against the ceiling and the wall of a room are at angles that, when added together, equal exactly  $90^\circ$ . Most crown molding has a top rear angle (the section that fits flat against the ceiling) of  $52^\circ$  and a bottom rear angle (the section that fits flat against the wall) of  $38^\circ$ .

## LAYING MOLDING FLAT ON THE MITER TABLE

See Figure 42.

To use this method for accurately cutting crown molding for a  $90^\circ$  inside or outside corner, lay the molding with its broad back surface flat on the miter table and against the fence.

When setting the bevel and miter angles for compound miters, remember that the settings are interdependent; changing one angle changes the other angle as well.

Keep in mind that the angles for crown moldings are very precise and difficult to set. Since it is very easy for these angles to shift, all settings should first be tested on scrap molding. Also most walls do not have angles of exactly  $90^\circ$ , therefore, you will need to fine tune your settings.

When cutting crown molding by this method the bevel angle should be set at  $33.9^\circ$  either right or left. The crown molding stops are marked either  $33.9^\circ$  or  $45^\circ$  for the exact angle for cutting crown molding. The miter angle should be set at  $31.6^\circ$  either right or left, depending on the desired cut for the application. See the chart on page 32 for correct angle settings and correct positioning of crown molding on miter table.

The settings in the chart on page 32 can be used for cutting All Standard (U.S.) crown molding with  $52^\circ$  and  $38^\circ$  angles. The crown molding is placed flat on the miter table using the compound features of your miter saw.

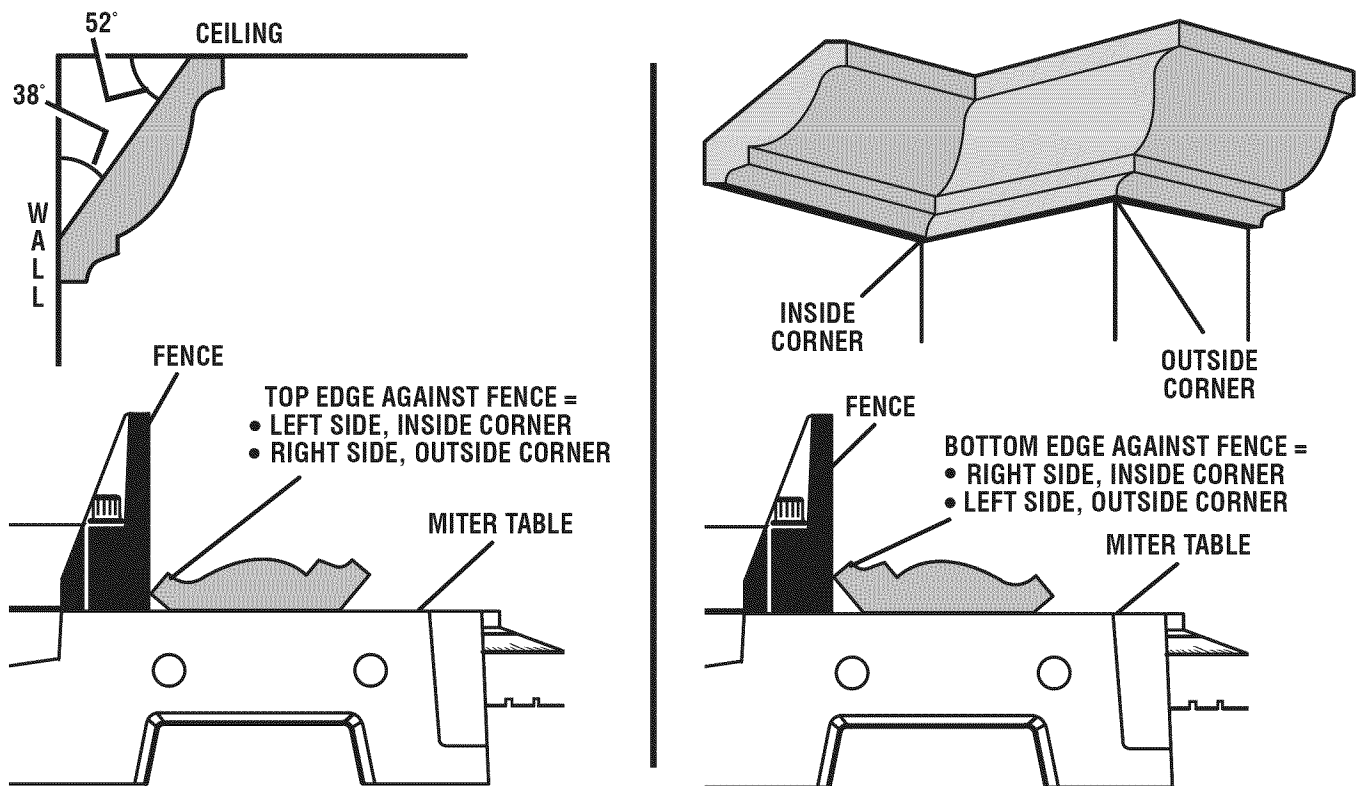

CROWN MOLDING FLAT ON MITER TABLE

Fig. 42

# OPERATION

Bevel Angle Setting	Type of Cut
33.85°	<b>Left side, inside corner</b> 1. Top edge of molding against fence 2. Miter table set right 31.62° 3. Save left end of cut
33.85°	<b>Right side, inside corner</b> 1. Bottom edge of molding against fence 2. Miter table set left 31.62° 3. Save left end of cut
33.85°	<b>Left side, outside corner</b> 1. Bottom edge of molding against fence 2. Miter table set left 31.62° 3. Save right end of cut
33.85°	<b>Right side, outside corner</b> 1. Top edge of molding against fence 2. Miter table set right 31.62° 3. Save right end of cut

## CUTTING MOLDING USING THE CROWN MOLDING STOP

See Figures 43 - 44.

To use this method for accurately cutting crown molding for a 90° inside or outside corner, place the crown molding upside down on the miter table.

Keep in mind that the angles for crown moldings are very precise and difficult to set. Since it is very easy for these angles to shift, all settings should first be tested on scrap molding. Also most walls do not have angles of exactly 90°, therefore, you will need to fine tune your settings.

When cutting crown molding by this method the bevel angle should be set at 0°. The miter angle should be set at 45° either right or left, depending on the desired cut for the application.

Using the markings on the throat plate, you can accurately cut All Standard (U.S.) with 52° and 38° angles in sizes of 2-3/4 in., 3-5/8 in., 4-5/8 in., and 5-1/4. You cannot use the markings on the throat plate when cutting crown molding with 45° and 45° angles.

- Loosen the crown molding stop by turning the knob counterclockwise.
- Place the stop in the hole on either the left or the right side of the saw's base. See figure 43.
- With the bottom of the molding (wall side) against the miter fence and the top of the molding (ceiling side) against the miter table, align with the desired mark on the throat plate then spin the crown molding stop until it fits snugly against the crown molding.
- Secure the crown molding stop in place by turning the knob clockwise.
- Hold the crown molding in place with your hand (the side not secured with the stop).  
**NOTE:** NEVER place your hand inside the "No Hands" zone while the saw is on.
- Grasp the saw handle firmly then squeeze the switch trigger. Allow several seconds for the blade to reach maximum speed.
- Slowly lower the blade into and through the workpiece.
- Release the switch trigger and allow the blade to stop rotating before raising the blade out of workpiece. Wait until the electric brake stops blade from turning before removing the workpiece from miter table.

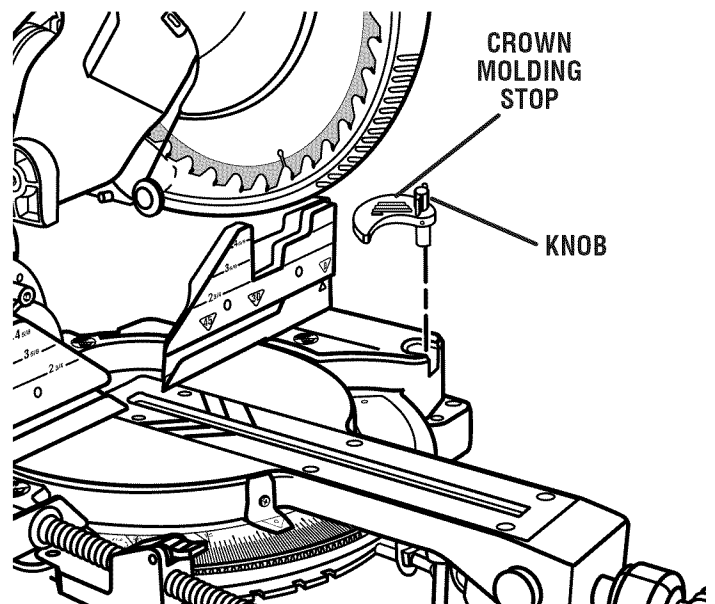

Fig. 43

# OPERATION

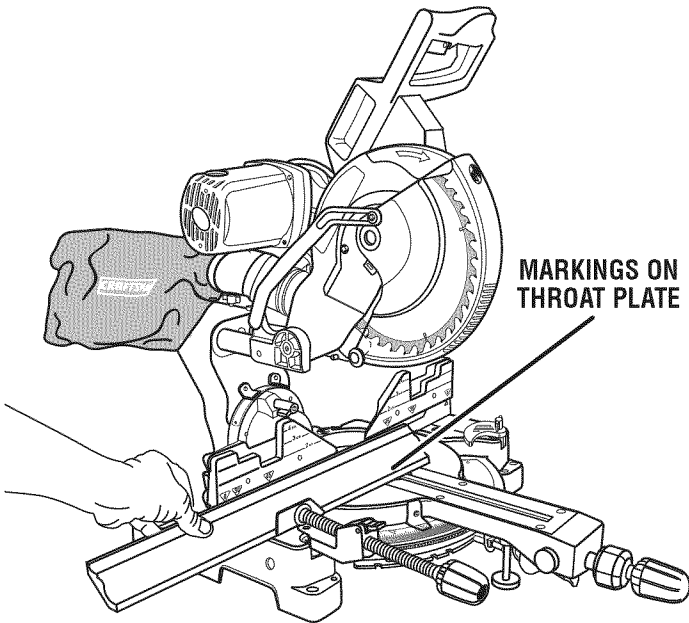
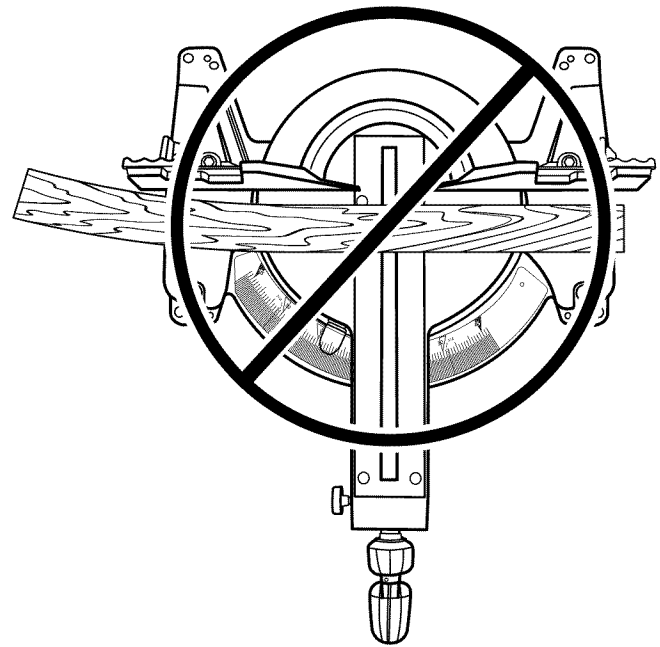

Fig. 44



WRONG

Fig. 46

## CUTTING WARPED MATERIAL

See Figures 45 - 46.

When cutting warped material, always make sure it is positioned on the miter table with the convex side against the fence as shown in figure 45.

If the warped material is positioned the wrong way as shown in figure 46, it will pinch the blade near the completion of the cut.

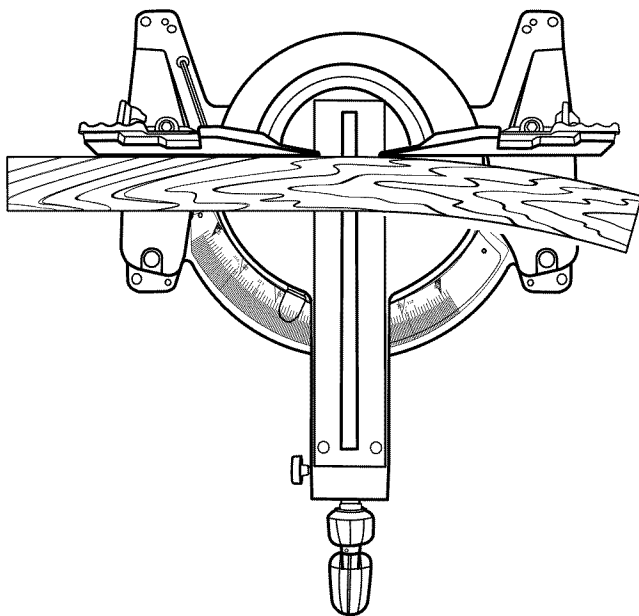

RIGHT

Fig. 45

## CLAMPING WIDE WORKPIECES

See Figure 47.

When cutting wide workpieces such as a 2 in. x 12 in., boards should be clamped with a C-clamp as shown in figure 47.

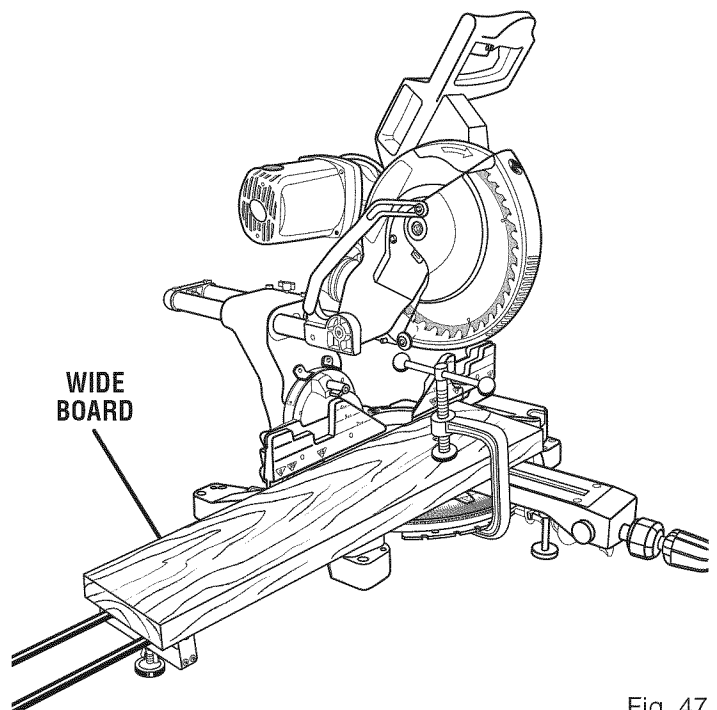

Fig. 47

# MAINTENANCE

**⚠ WARNING:** When servicing, use only identical replacement parts. Use of any other part may create a hazard or cause product damage.

**⚠ WARNING:** Always wear safety goggles or safety glasses with side shields during power tool operation or when blowing dust. If operation is dusty, also wear a dust mask.

## GENERAL

Avoid using solvents when cleaning plastic parts. Most plastics are susceptible to damage from various types of commercial solvents and may be damaged by their use. Use clean cloths to remove dirt, carbon dust, etc.

**⚠ WARNING:** Do not at any time let brake fluids, gasoline, petroleum-based products, penetrating oils, etc. come in contact with plastic parts. Chemicals can damage, weaken or destroy plastic which may result in serious personal injury.

Electric tools used on fiberglass material, wallboard, spackling compounds, or plaster are subject to accelerated wear and possible premature failure because the fiberglass chips and grindings are highly abrasive to bearings, brushes, commutators, etc. Consequently, we do not recommend using this tool for extended work on these types of materials. However, if you do work with any of these materials, it is extremely important to clean the tool using compressed air.

## LUBRICATION

All of the bearings in this tool are lubricated with a sufficient amount of high grade lubricant for the life of the unit under normal operating conditions. Therefore, no further lubrication is required.

**⚠ WARNING:** To ensure safety and reliability, all repairs — with the exception of the externally accessible brushes — should be performed by a qualified service technician at a Sears store to avoid risk of personal injury.

## BRUSH REPLACEMENT

See Figure 48.

Your saw has externally accessible brush assemblies that should be periodically checked for wear.

**Proceed as follows when replacement is required:**

■ Unplug the saw.

**⚠ WARNING:** Failure to unplug the saw could result in accidental starting causing serious injury.

- Remove brush cap with a screwdriver. Brush assembly is spring loaded and will pop out when you remove brush cap.
- Remove brush assembly.
- Check for wear. Replace both brushes when either has less than 1/4 in. length of carbon remaining. **Do not** replace one side without replacing the other.
- Reassemble using new brush assemblies. Make sure curvature of brush matches curvature of motor and that brush moves freely in brush tube.
- Make sure brush cap is oriented correctly (straight) and replace.
- Tighten brush cap securely. **Do not** overtighten.

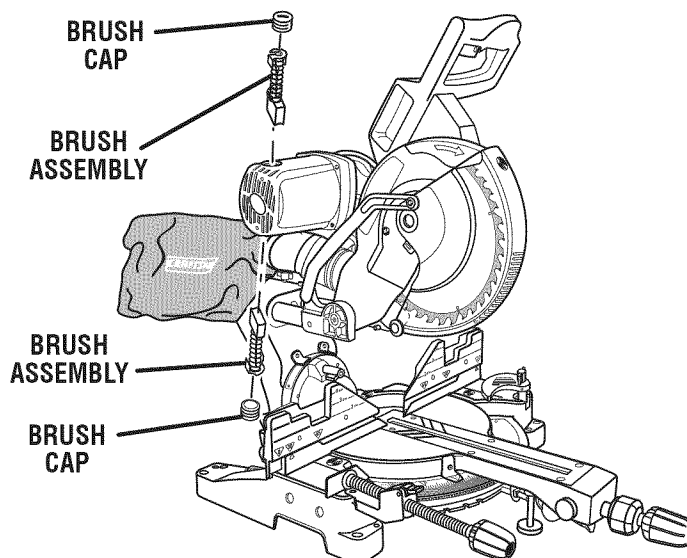

Fig. 48

# MAINTENANCE

## BELT REPLACEMENT

See Figures 49 - 50.

The saw is powered by a belt-driven motor. Periodically check the belt for wear and replace it when necessary.

**Proceed as follows when replacement is required:**

- Unplug the saw.

**⚠ WARNING:** Failure to unplug the saw could result in accidental starting causing serious injury.

- Pull saw arm all the way down and engage the lock pin to hold the saw arm in transport position.
- Using a phillips screwdriver, remove the screws from the belt cover. Carefully lift the belt cover off the housing and set aside.
- Loosen the adjustment screws.
- Loosen the set screw on the motor housing. Push the motor housing down until there is enough slack in the belt for it to be removed from around the pulleys.
- Place the new belt (grooves turned to the inside) around the bottom pulley.
- Push the motor housing down with one hand while pulling the belt up and over the second pulley with the other hand. Release the motor housing.
- Turn the belt by hand until you are certain it is properly aligned on the grooves of the pulleys.
- Lift the motor housing up and retighten the set screw.
- Check belt tension by squeezing the belt. Using light pressure, the belt should deflect approximately 1/4 in.
- **NOTE:** If belt tension is not correct, adjust the set screw until tension is correct.
- Once belt tension is correct, retighten adjustment screws.
- Reinstall the belt cover with the phillips screws.

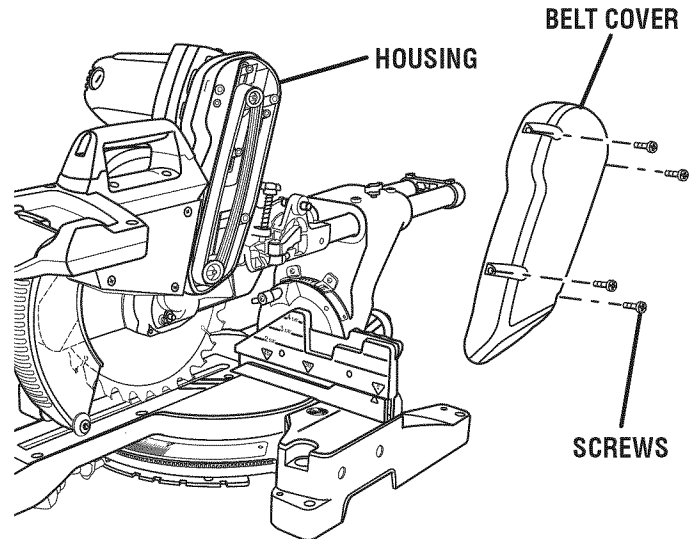

Fig. 49

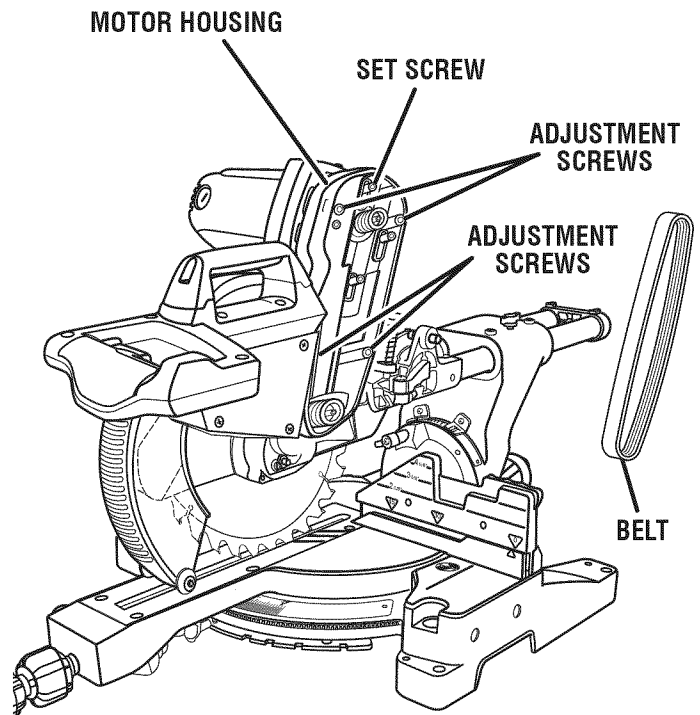

Fig. 50

# MAINTENANCE

## CHANGING THE BATTERIES

See Figure 51.

- Unplug the saw.
- Rotate and hold lower blade guard up.
- Using the hex key (1/16 in.) provided, loosen and remove the screw from the battery cover then separate the cover from the laser guide. Lower the blade guard.
- Remove the three button cell batteries.

**NOTE:** Replace the batteries with button cell batteries that have a rating of 1.5 volt and 100 mAh (milliampere hour) minimum (number 76 series or equivalent).

When replacing the batteries, the laser guide should be thoroughly cleaned. Use a soft paintbrush, or similar device, to remove all sawdust and debris.

- After cleaning the laser guide and replacing batteries, secure battery cover to laser guide using the screw. Tighten screw securely.

**CAUTION:** Use of controls or adjustments or performance of procedures other than those specified herein may result in hazardous radiation exposure.

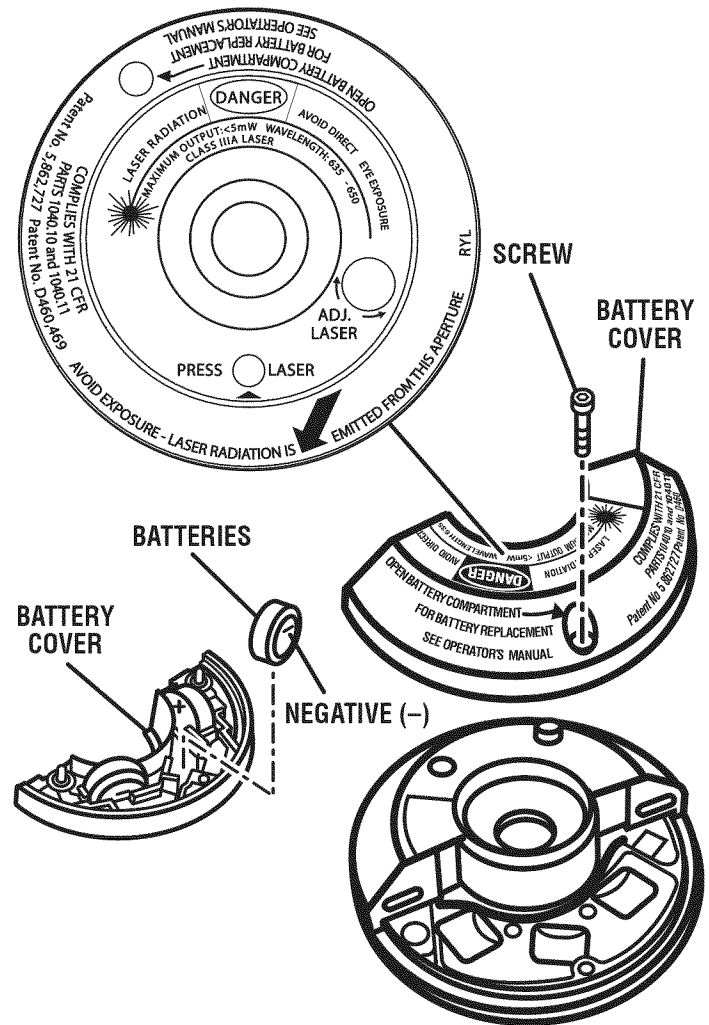

Fig. 51

# MAINTENANCE

## ADJUSTING THE LASER GUIDE

See Figure 52.

**NOTE:** Avoid direct eye exposure when using the laser guide.

- Set both the bevel angle and the miter table at 0°.
- Use the optional work clamp or a C-clamp to secure a piece of scrap wood.
- Plug the saw into the power source and make a slight cut to score the wood.
- Raise the saw arm and unplug the saw.
- Lift and hold the lower blade guard.
- Loosen the phillips screw on the blade bolt cover until the cover can be raised.
- Gently raise the lower blade guard bracket so that lower blade guard and blade bolt cover can be rotated up and back to expose the laser.
- Rotate the blade by hand until you can push and hold the laser button and the laser is near the center of the workpiece as shown in figure 52.
- To adjust the laser, turn the adjustment screw counterclockwise or clockwise using the hex key (1/16 in.) provided.

**NOTE:** When properly aligned, the laser should be on the left edge of the kerf.

- Once aligned, remove and store the hex key (1/16 in.), and lower the blade guard.
- Replace the lower blade guard and blade bolt cover.
- Retighten the phillips screw securing the blade bolt cover.

**NOTE:** Always make practice cuts on scrap wood before cutting through your workpiece.

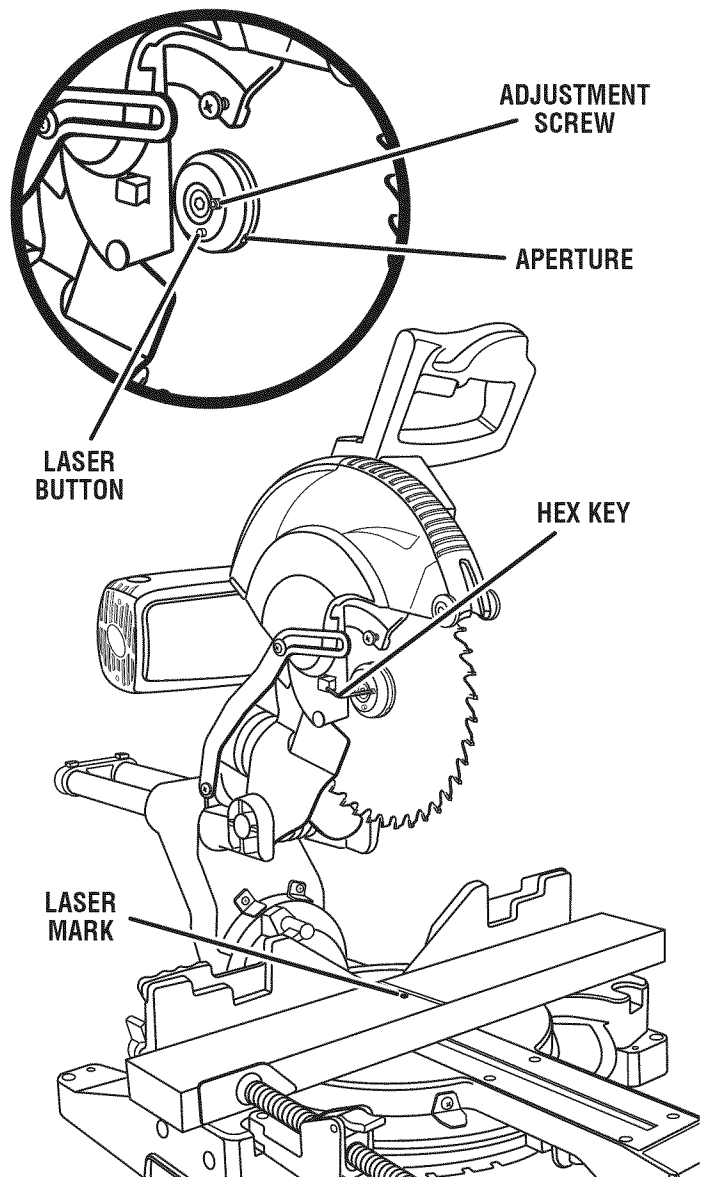

Fig. 52

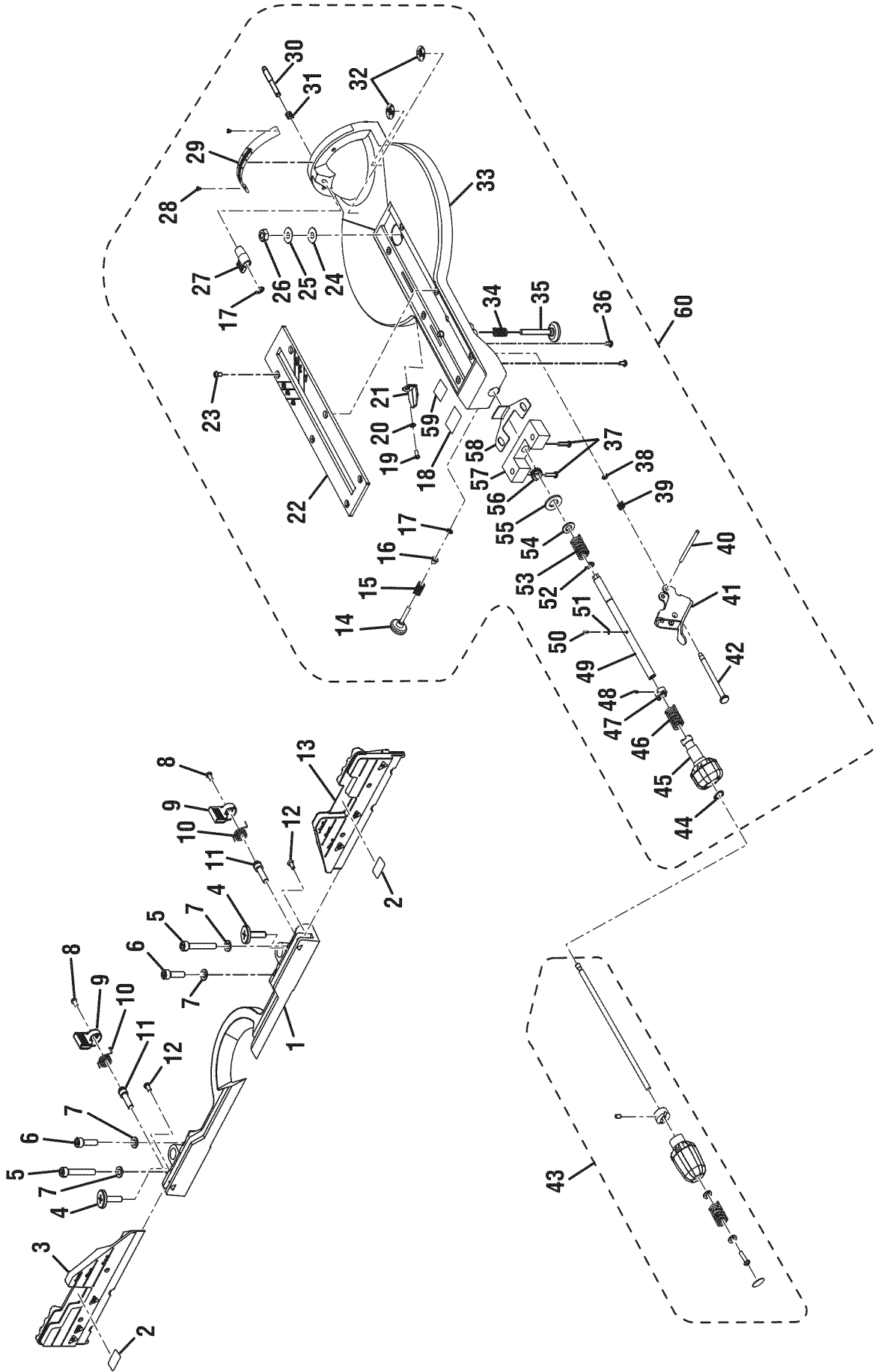

Figure A

## CRAFTSMAN COMPOUND MITER SAW – MODEL NUMBER 315.315.212010

The model number will be found on a plate attached to the motor housing. Always mention the model number in all correspondence regarding your **MITER SAW** or when ordering repair parts.

### PARTS LIST FOR FIGURE A

KEY PART NO.	PART NUMBER	DESCRIPTION	QTY.	KEY PART NO.	PART NUMBER	DESCRIPTION	QTY.
1	089100110067	Fence, Base.....	1	31	089100110016	Spring, Bevel Lock Pin .....	1
2	089100110071	Warning Label (Sliding Fence).....	2	32	089100110007	Warning Label (No Hands).....	2
3	089100110069	Slide Fence (left, Incl. Key No. 2).....	1	33	089100110025	Table (Incl. Key Nos. 28-29).....	1
4	089100110070	T-Bolt, Slide Fence .....	2	34	089100110014	Spring, Foot.....	1
5	A07103080457	* Screw (M8 x 45 mm, Hex Soc. Hd.) .....	2	35	089100110013	Leveler .....	1
6	A07003080208	* Screw (M8 x 20 mm, Hex Hd.).....	2	36	545407000	* Screw (M5 x 12 mm).....	2
7	A36030814204	Spring Washer (M8).....	4	37	089100110036	* Screw (M4 x 25 mm, Hex Soc. Hd.) .....	2
8	A16003040083	* Screw (M4 x 8 mm, Flat Hd.) .....	2	38	089100110048	E-Ring.....	1
9	089100110061	Fence Screw Lever.....	2	39	089100110047	Spring .....	1
10	089100110062	Spring .....	2	40	089100110046	Shaft .....	1
11	089100110063	Pivot.....	2	41	089100110045	Lever.....	1
12	089100110068	Screw (M4 x 5 mm, Hex Soc. Hd.) .....	2	42	089100110044	Miter Quick Lock Pin .....	1
13	089100110059	Slide Fence (right, Incl. Key No. 2) .....	1	43	089100110713	Miter Knob Lock Pin Assembly .....	1
14	089100110029	Release Knob .....	1	44	089100110043	C-Ring .....	1
15	089100110030	Spring .....	1	45	089100110042	Knob, Fine Miter Adjustment.....	1
16	089100110031	Spacer .....	1	46	089100110035	Spring, Fine Miter Adjustment.....	1
17	089100110020	E-Ring.....	2	47	089100110057	Coupling .....	1
18	089100110901	Label, Micro Adjust.....	1	48	089100110032	Set Screw (M4 x 6 mm, Nylock) .....	1
19	A10003050105	* Screw (M5 x 10 mm, Pan Hd.).....	1	49	089100110041	Pipe.....	1
20	A35010510010	* Washer (5 x 10 x 1t) .....	1	50	089100110254	* Screw (M4 x 4 mm).....	1
21	089100110026	Miter Indicator .....	1	51	A36030407016	* Spring Washer (M4) .....	1
22	089100110024	Throat Plate .....	1	52	089100110038	E-Ring.....	1
23	A10003060103	* Screw (M6 x 10 mm, Pan Hd.).....	6	53	089100110039	Spring .....	1
24	089100110251	Washer (D8.2 x D20 x 1.5T) .....	1	54	089100110040	* Flat Washer (14 x 20 x 1t).....	1
25	089100110022	Washer (D25 x D10 x 1.5T) .....	1	55	089100110012	* Flat Washer (14 x 19 x 2.5t).....	1
26	A31703008000	Lock Nut (M8) .....	1	56	089100110037	Pinion .....	1
27	089100110019	Bevel Stop Pin Lever .....	1	57	089100110034	Block, Miter Lock.....	1
28	A49010020056	* Rivet (2.5 x 5 mm).....	2	58	089100110033	Plate, Miter Lock.....	1
29	089100110018	Bevel Scale.....	1	59	089100110900	Knob Label .....	1
30	089100110015	Bevel Lock Pin.....	1	60	089100110701	Table Assembly (Incl. Key Nos. 14-42, 44-59).....	1

\* Standard Hardware Item — May Be Purchased Locally

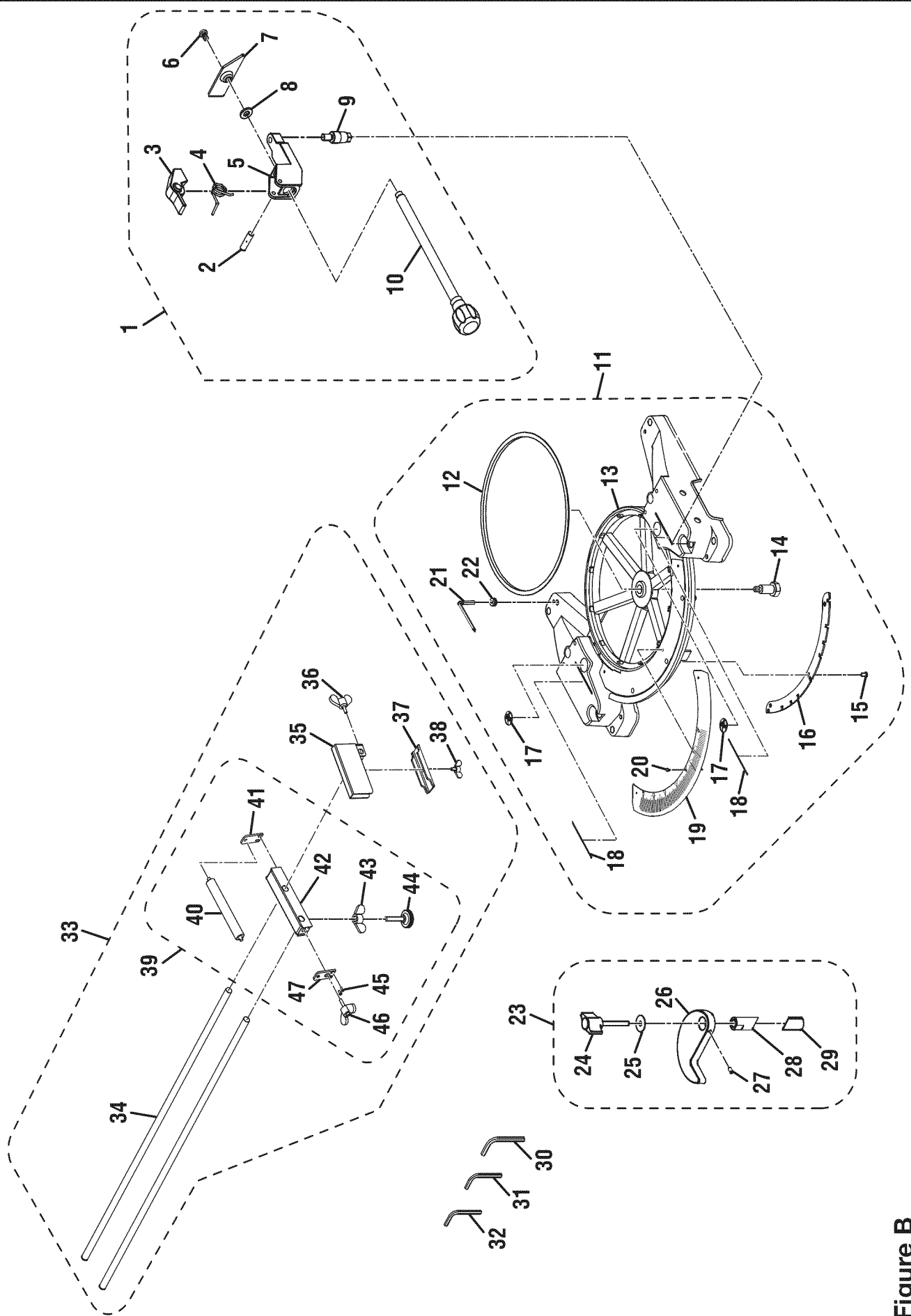

Figure B

**CRAFTSMAN COMPOUND MITER SAW – MODEL NUMBER 315.212010**

The model number will be found on a plate attached to the motor housing. Always mention the model number in all correspondence regarding your **MITER SAW** or when ordering repair parts.

**PARTS LIST FOR FIGURE B**

KEY NO.	PART NO.	DESCRIPTION	QTY.	KEY NO.	PART NO.	DESCRIPTION	QTY.
1	089100110800	Work Clamp Assembly (Incl. Key Nos. 2-10)	1	24	565507000	Crown Molding Knob	1
2	A42001060300	Quick Release Pin	1	25	A35010823020	* Flat Washer (8 x 23 x 2t)	1
3	701106000	Quick Release	1	26	565504000	Crown Molding Clamp	1
4	701107000	Torsion Spring	1	27	A18003040080	* Set Screw (M4 x 8 mm)	1
5	545503000	Work Clamp Base	1	28	565505000	Upper Tube, Adjustable	1
6	A10003060158	* Screw (M6 x 15 mm, Pan Hd.)	1	29	565506000	Lower Tube, Adjustable	1
7	503511000	Clamp Plate	1	30	A07910420000	*** Hex Key (4 mm)	1
8	A35031020300	* Flat Washer (10 x 20 x 3t)	1	31	089100110229	*** Hex Key (6 mm)	1
9	503507000	Spindle	1	32	089100110258	*** Hex Key (8 mm)	1
10	089100110212	Work Clamp Knob	1	33	089100110804	Roller Support Assembly (Incl. Key Nos. 34-47)	1
11	089100110700	Base Assembly (Incl. Key Nos. 12-22)	1	34	545512000	Table Extension	2
12	089100110049	Wear Ring	1	35	558507200	Stop Block	1
13	089100110001	Base	1	36	558512100	Wing Screw	1
14	089100110002	Table Spindle	1	37	558511100	Clamp Bracket	1
15	089100110004	Screw (Hex Soc. Hd.)	3	38	555516000	Wing Screw	1
16	089100110003	Miter Lock Plate	1	39	545A07030	Roller Base Assembly (Incl. Key Nos. 40-47)	1
17	089100110007	Hand Warning Label	2	40	545508000	Roller	1
18	565109000	Line Label	2	41	545506000	Roller Support Front Brace	1
19	089100110005	Miter Scale	1	42	545507000	Roller Base	1
20	A49010020056	Rivet	3	43	A33055056000	* Wing Nut (5/16 in.)	1
21	503121000	*** Hex Key (5 mm)	1	44	545509000	Adjustable Bolt (5/16 in.)	1
22	503118000	Grommet	1	45	A10003040050	Screw (M4 x 5 mm, Pan Hd.)	4
23	565A07020	Crown Molding Stop Assembly (Incl. Key Nos. 24-29)	1	46	545511000	* Wing Screw (M8 x 20 mm)	1
				47	545505000	Roller Support End Brace	1

\* Standard Hardware Item – May Be Purchased Locally  
 \*\*\* Available At Your Nearest Sears Catalog Order or Retail Store

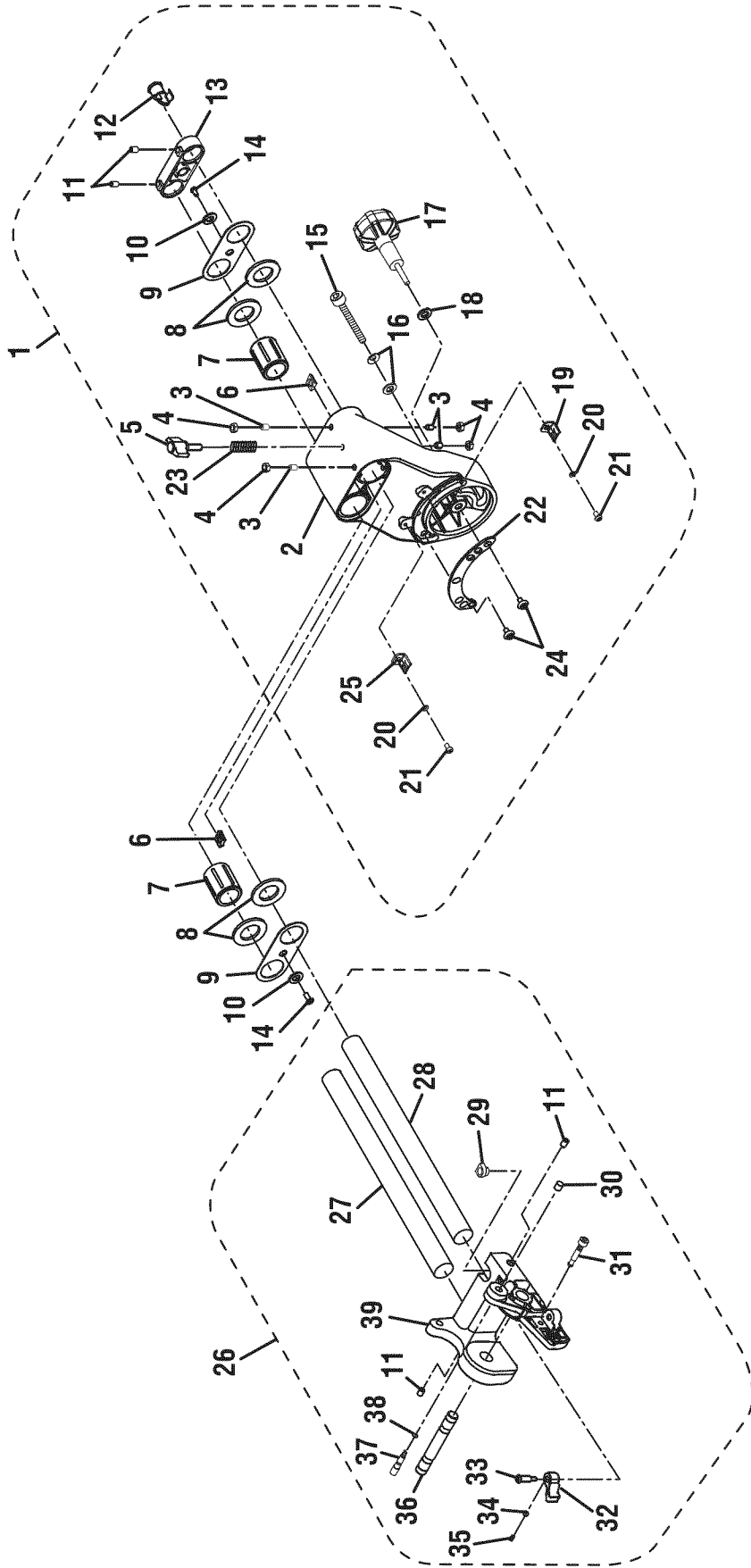

Figure C

**CRAFTSMAN COMPOUND MITER SAW – MODEL NUMBER 315.212010**

The model number will be found on a plate attached to the motor housing. Always mention the model number in all correspondence regarding your **MITER SAW** or when ordering repair parts.

**PARTS LIST FOR FIGURE C**

KEY NO.	PART NUMBER	DESCRIPTION	QTY.	KEY NO.	PART NUMBER	DESCRIPTION	QTY.
1	089100110704	Pivot & Pivot Support Assembly (Incl. Key Nos. 2-16, 18-25)	1	20	A35010510010	* Washer (5 x 10 x 1t)	2
2	089100110090	Pivot Bracket, Bevel	1	21	A10003050105	* Screw (M5 x 10 mm, Pan Hd.)	2
3	089100110091	Set Screw (M8 x 18 mm)	4	22	089100110088	Bevel Lock Plate	1
4	A30003008001	* Hex Nut (M8)	4	23	089100110249	Spring	2
5	089100110093	Fixed Screw, Rail	1	24	089100110085	* Screw (M6 x 12 mm, Flat Hex Socket Hd.)	2
6	089100110098	Spacer, Rail Cover	4	25	089100110089	Bevel Indicator (left)	1
7	089100110099	Linear Bearing	2	26	089100110703	Pivot Bracket Bevel Assembly (Incl. Key Nos. 11 and 27-39)	1
8	089100110100	Dust Seal	4	27	089100110084	Slide Rail A	1
9	089100110101	Plate, Rail Cover	2	28	089100110083	Slide Rail B	1
10	089100110102	Bumper, Rail	2	29	089100110082	Grommet	1
11	089100110105	Set Screw (M8 x 10 mm, Nylock)	4	30	545209000	Stop Pin Cap	1
12	089100110106	Strain Relief	1	31	089100110074	Pin, Spring	1
13	089100110104	Rear Cap, Rail	1	32	089100110076	Block, Groove Set Up	1
14	A10003050120	* Screw (M5 x 12 mm, Pan Hd.)	2	33	089100110077	Bolt, Groove Set Up	1
15	089100110097	Screw (M10 x 48 mm Hex Socket Hd., Trilobular)	1	34	089100110072	Steel Ball	1
16	089100110094	Wavy Washer	2	35	089100110073	Spring	1
17	089100110096	Bevel Lock Knob	1	36	089100110078	Pivot Shaft	1
18	A35030401008	* Washer (4 x 10 x 1t)	1	37	089100110081	Pin, Fixed	1
19	089100110087	Bevel Indicator (right)	1	38	A63000000051	O-Ring	1
				39	089100110075	Pivot Bracket, Guard	1

\* Standard Hardware Item — May Be Purchased Locally

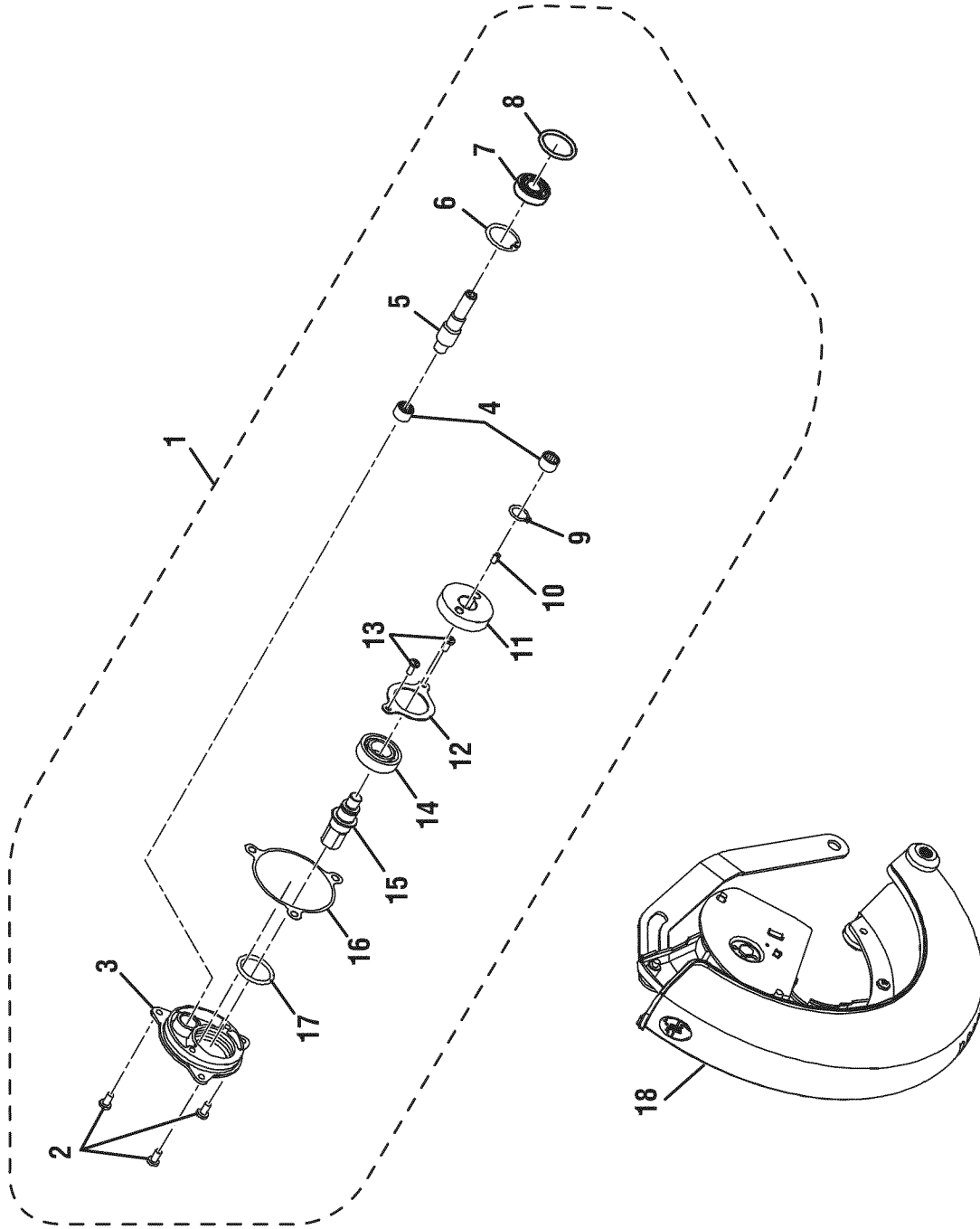

Figure D

**CRAFTSMAN COMPOUND MITER SAW – MODEL NUMBER 315.212010**

The model number will be found on a plate attached to the motor housing. Always mention the model number in all correspondence regarding your **MITER SAW** or when ordering repair parts.

**PARTS LIST FOR FIGURE D**

KEY NO.	PART NUMBER	DESCRIPTION	QTY.	KEY NO.	PART NUMBER	DESCRIPTION	QTY.
1	089100110709	Gear Case Assembly (Incl. Key Nos. 2-17)	1	10	A45204040080	Parallel Key (4 x 4 x 8)	1
2	A10003060156	* Screw (M6 x 15 mm, Pan Hd.)	3	11	545309000	Master Gear	1
3	545306000	Bearing Cover	1	12	545310000	Bearing Plate	1
4	A53010100000	Needle Bearing	2	13	A10003040066	* Screw (M4 x 6 mm, Pan Hd. Nylock)	2
5	545311000	Gear Shaft	1	14	A50060030041	Ball Bearing (6003Z/RS)	1
6	A46100280000	C-Ring	1	15	545308000	Gear Shaft / Arbor	1
7	A50060010050	Ball Bearing (6001 2RS)	1	16	565306000	Gasket	1
8	A63030001220	O-Ring	1	17	A63030001260	O-Ring	1
9	A46000150008	C-Ring	1	18	089100110708	Lower Guard Assembly	1

\* Standard Hardware Item -- May Be Purchased Locally

**Note:** For Laser Guide repair or replacement, contact your nearest Sears Service Center

11

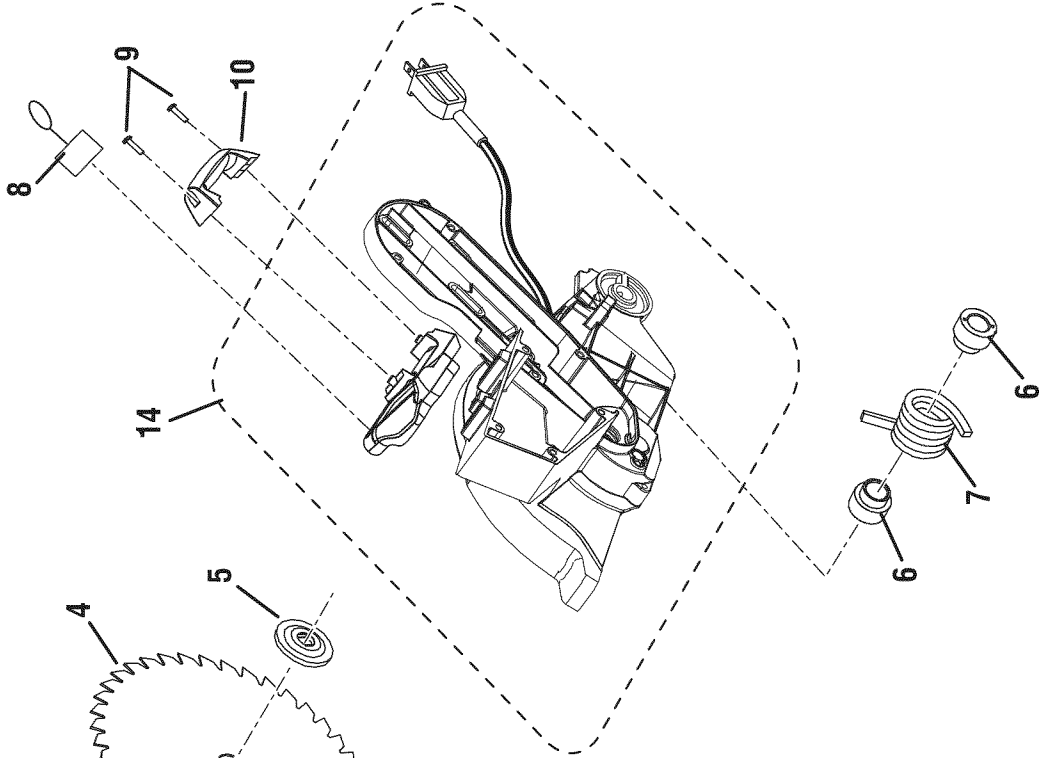
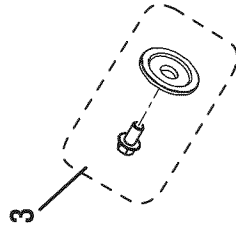
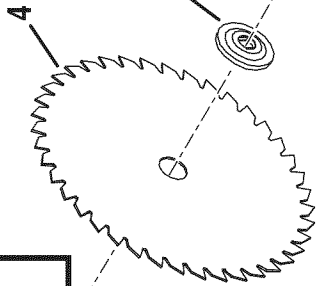

Figure E

**CRAFTSMAN COMPOUND MITER SAW – MODEL NUMBER 315.212010**

The model number will be found on a plate attached to the motor housing. Always mention the model number in all correspondence regarding your **MITER SAW** or when ordering repair parts.

**PARTS LIST FOR FIGURE E**

KEY NO.	PART NUMBER	DESCRIPTION	QTY.	KEY NO.	PART NUMBER	DESCRIPTION	QTY.
1	511505000	Laser Guide Bolt.....	1	8	089100110247	Hang Tag (Tip Over).....	1
2	089100300723	Adjustable Laser.....	1	9	A70003060250	* Screw (M6 x 25 mm).....	2
3	089100110805	Flange / Arbor Bolt Set.....	1	10	545328000	Carrying Handle.....	1
4	510502007	*** Blade.....	1	11	089100300719	Adjustable Laser Replacement Kit (Inc. Key Nos. 1-2 and 12-13).....	1
5	588035105	Inner Blade Washer.....	1	12	089100300726	* Hex Key (1/16 in.).....	1
6	538327000	Spacer.....	2	13	089100300727	Warning Label.....	1
7	089100110107	Torsion Spring.....	1	14	089100110707	Upper Guard Assembly.....	1

\* Standard Hardware Item – May Be Purchased Locally  
 \*\*\* Complete Assortment Available At Your Nearest Sears Catalog Order or Retail Store

**NOTE:** The assembly shown represents an important part of the Double Insulated System. To avoid the possibility of alteration or damage to the system, service should be performed by your nearest Sears Repair Center. Contact your nearest Sears Catalog Order or Retail Store for Service Center Information.

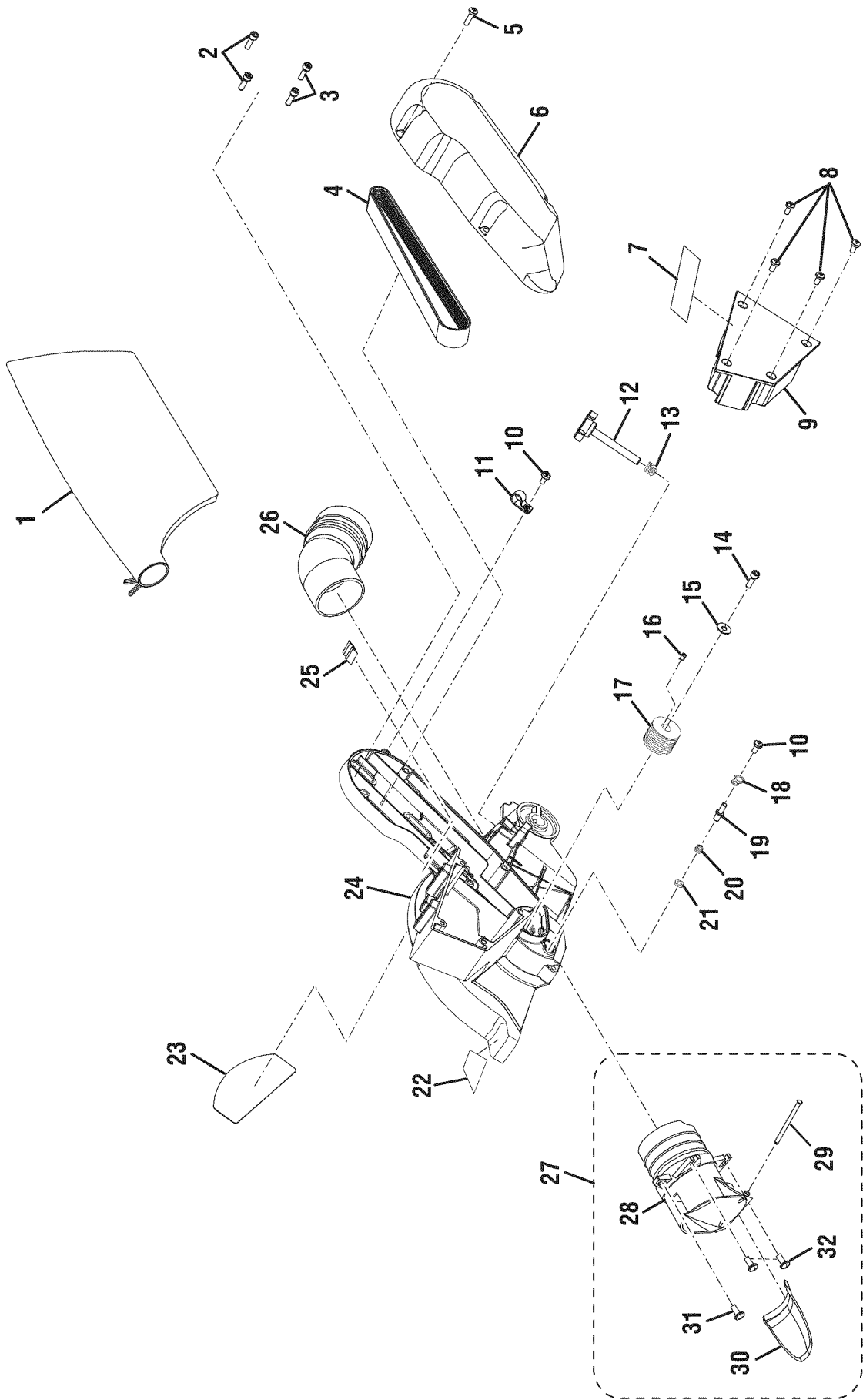

Figure F

**CRAFTSMAN COMPOUND MITER SAW – MODEL NUMBER 315.212010**

The model number will be found on a plate attached to the motor housing. Always mention the model number in all correspondence regarding your **MITER SAW** or when ordering repair parts.

**PARTS LIST FOR FIGURE F**

KEY NO.	PART NUMBER	DESCRIPTION	QTY.	KEY NO.	PART NUMBER	DESCRIPTION	QTY.
1	089100110221	Dust Bag.....	1	18	545305000	Lock Pin Plate .....	1
2	A07203060200	* Screw w/ Washer (M6 x 20 mm, Hex Socket Hd.) .....	2	19	089100110113	Arbor Lock Pin.....	1
3	089100110146	Screw (Hex Socket Hd.) .....	2	20	545303000	Compression Spring.....	1
4	545320000	Belt.....	1	21	545304000	Felt Washer (6 x 10 x 2t).....	1
5	A10003050180	* Screw (M5 x 18 mm, Pan Hd.) .....	4	22	089100110121	Label, Belt Cover.....	1
6	545321000	Belt Cover.....	1	23	545329000	Logo Label .....	1
7	089100110159	Logo Label .....	1	24	089100110132	Upper Guard.....	1
8	A16003050100	* Screw (M5 x 10 mm, Pan Hd.) .....	4	25	E07010000450	Sleeve.....	1
9	089100110139	Cavity (Plastic Cover) .....	1	26	545501000	Dust Guide .....	1
10	A10003050105	Screw (M5 x 10 mm, Pan Hd.) .....	2	27	089100110705	Dust Chute Assembly (Incl. Key Nos. 28-31) .....	1
11	E07000846157	Cord Clamp .....	1	28	089100110116	Dust Collector .....	1
12	089100110137	Screw, Groove Set Up.....	1	29	089100110110	Pin, Dust Chute .....	1
13	089100110136	Spring .....	1	30	089100110109	Dust Chute .....	1
14	A07013050150	* Screw (M5 x 15 mm, Hex Socket Hd.) .....	1	31	A19003050120	Screw (M5 x 12 mm, Pan Hd.) .....	1
15	A35010519150	* Washer (5 x 19 x 1.5t).....	1	32	089100110111	* Screw (M5 x 15 mm, Pan Hd.) .....	2
16	A45204040080	Parallel Key (4 x 4 x 8).....	1	33	089100110706	Upper Arm Assembly (Incl. Key Nos. 2-26).....	1
17	545312000	Arbor Pulley .....	1				

\* Standard Hardware Item – May Be Purchased Locally

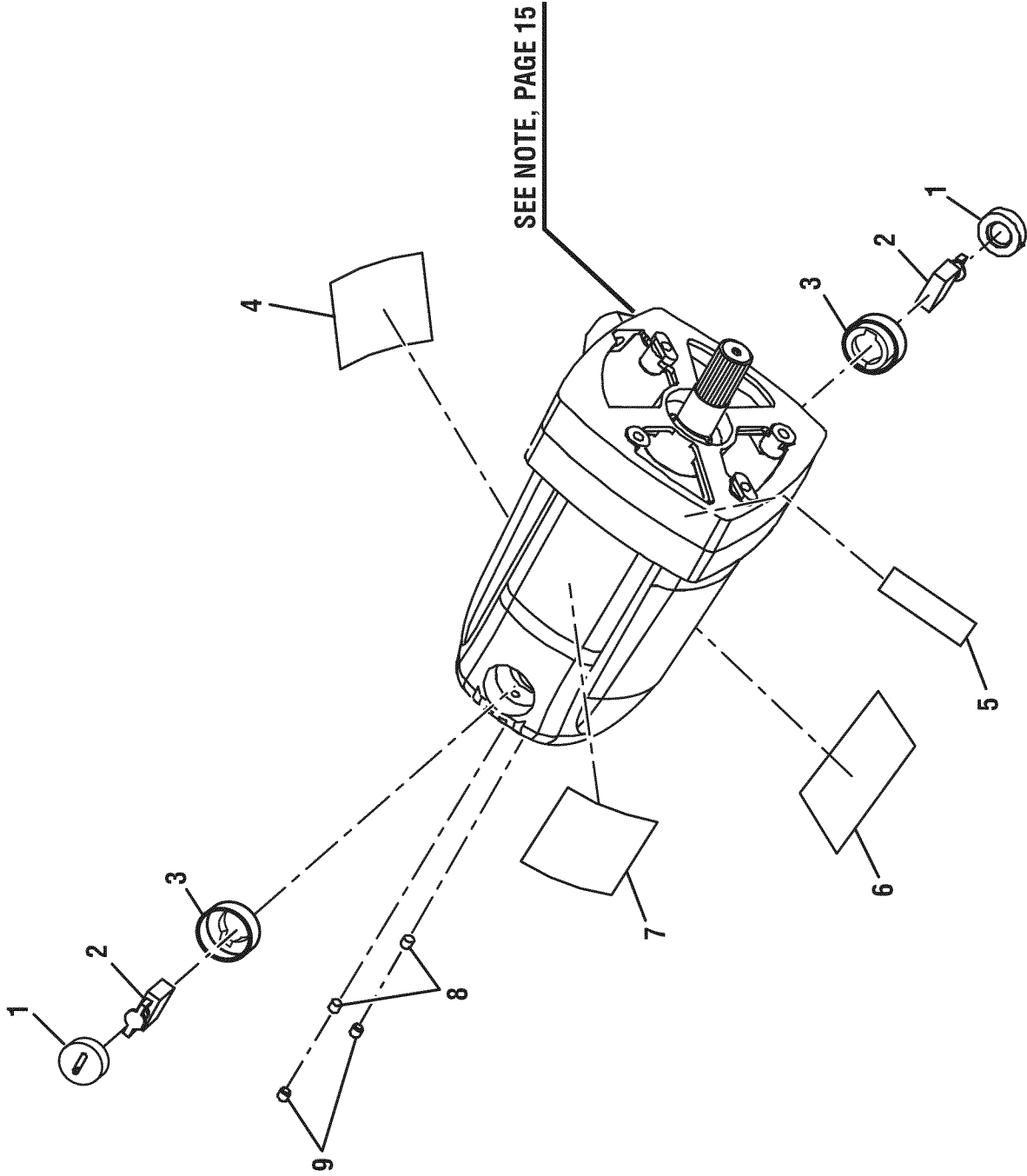

Figure G

**CRAFTSMAN COMPOUND MITER SAW – MODEL NUMBER 315.212010**

The model number will be found on a plate attached to the motor housing. Always mention the model number in all correspondence regarding your **MITER SAW** or when ordering repair parts.

**PARTS LIST FOR FIGURE G**

KEY NO.	PART NUMBER	DESCRIPTION	QTY.	KEY NO.	PART NUMBER	DESCRIPTION	QTY.
1	588005105	Brush Holder Cap .....	2	6	089100110211	Data Label.....	1
2	089100110209	Brush Assembly .....	2	7	089100110206	Indication Label.....	1
3	588007305	Brush Holder .....	2	8	A95001050060	*Set Screw (M5 x 6 mm).....	2
4	511353000	Warning Label.....	1	9	A18003050054	*Set Screw (M5 x 5 mm).....	2
5	545331000	Label, Belt Adjustment Warning .....	1		983000982	Operator's Manual	

\* Standard Hardware Item -- May Be Purchased Locally

**NOTE:** The assembly shown represents an important part of the Double Insulated System. To avoid the possibility of alteration or damage to the system, service should be performed by your nearest Sears Repair Center. Contact your nearest Sears Catalog Order or Retail Store for Service Center Information.





# Get it fixed, at your home or ours!

## Your Home

For repair – **in your home** – of **all** major brand appliances, lawn and garden equipment, or heating and cooling systems, **no matter who made it, no matter who sold it!**

For the replacement parts, accessories and owner's manuals that you need to do-it-yourself.

For Sears professional installation of home appliances and items like garage door openers and water heaters.

**1-800-4-MY-HOME®** (1-800-469-4663)

Call anytime, day or night (U.S.A. and Canada)

[www.sears.com](http://www.sears.com)    [www.sears.ca](http://www.sears.ca)

---

## Our Home

For repair of carry-in items like vacuums, lawn equipment, and electronics, call or go on-line for the location of your nearest

**Sears Parts & Repair Service Center**

**1-800-488-1222**

Call anytime, day or night (U.S.A. only)

[www.sears.com](http://www.sears.com)

---

To purchase a protection agreement (U.S.A.) or maintenance agreement (Canada) on a product serviced by Sears:

**1-800-827-6655** (U.S.A.)

**1-800-361-6665** (Canada)

---

Para pedir servicio de reparación a domicilio, y para ordenar piezas:

**1-888-SU-HOGAR®**

(1-888-784-6427)

Au Canada pour service en français:

**1-800-LE-FOYER<sup>MC</sup>**

(1-800-533-6937)

[www.sears.ca](http://www.sears.ca)

