

Use & Care Guide
Manual de Uso y Cuidado
English / Español



Models/Modelos: 148.16154211
Item / Artículo: 640-03838917-7

Kenmore®

4-Burner Gas Grill with Folding Side Shelves Parilla a gas de propane liquido



Sears P/N 2818-2B, 2818-2R, 2818-2S & Kmart P/N 2818-2B-Manual
Sears Brands Management Corporation
Hoffman Estates, IL 60179 U.S.A.
www.kenmore.com
www.sears.com
www.kmart.com





 **DANGER** 

If you smell gas:

1. Shut off gas to the appliance.
2. Extinguish any open flame.
3. Open lid.
4. If odor continues, keep away from the appliance and immediately call your gas supplier or your fire department.

 **WARNING** 

1. Do not store or use gasoline or other flammable liquids or vapors in the vicinity of this or any other appliance.
2. An LP cylinder not connected for use shall not be stored in the vicinity of this or any other appliance.

 **WARNING** 

CALIFORNIA PROPOSITION 65

1. Combustion by-products produced when using this product contain chemicals known to the State of California to cause cancer, birth defects, and other reproductive harm.
2. This product contains chemicals, including lead and lead compounds, known to the State of California to cause cancer, birth defects or other reproductive harm.

Wash your hands after handling this product.

Call Grill Service Center For Help And Parts

If you have questions or need assistance during assembly, please call 1-800-482-0131. You will be speaking to a representative of the grill manufacturer and not a Sears employee. To order new parts call Sears at 1-800-4-MY-HOME.



Product Record

IMPORTANT: Fill out the product record information below.

Model Number: 148.16154211
 148.16154211
 148.16154211

Serial Number: _____
 See rating label on grill for serial number.

Date Purchased: _____

 **CAUTION** 



For residential use only. Do not use for commercial cooking.

Installation Safety Precautions



- Use grill, as purchased, only with LP (propane) gas and the regulator/valve assembly supplied. A conversion kit must be purchased for use with natural gas.
- Grill installation must conform with local codes, or in their absence of local codes, with either the *National Fuel Gas Code, ANSI Z223.1/NFPA 54, Natural Gas and Propane Installation Code, CSA B149.1, or Propane Storage and Handling Code, B149.2, or the Standard for Recreational Vehicles, ANSI A 119.2/NFPA 1192, and CSA Z240 RV Series, Recreational Vehicle Code, as applicable.*
- All electrical accessories (such as rotisserie) must be electrically grounded in accordance with local codes, or *National Electrical Code, ANSI / NFPA 70 or Canadian Electrical Code, CSA C22.1.* Keep any electrical cords and/or fuel supply hoses away from any hot surfaces.
- This grill is safety certified for use in the United States and/or Canada only. Do not modify for use in any other location. Modification will result in a safety hazard.

Safety Symbols



The symbols and boxes shown below explain what each heading means. Read and follow all of the messages found throughout the manual.

 **DANGER** 

DANGER: Indicates an imminently hazardous situation which, if not avoided, will result in death or serious injury.

 **WARNING** 

WARNING: Indicates an potentially hazardous situation which, if not avoided, could result in death or serious injury.

 **CAUTION** 

CAUTION: Indicates a potentially hazardous situation or unsafe practice which, if not avoided, may result in minor or moderate injury.



TABLE OF CONTENTS

For Your Safety	2
Grill Service Center.	2
Product Record Information	2
Safety Symbols.	2
Installation Safety Precautions	2
Kenmore Grill Warranty	3
Use and Care	4-10
Natural Gas Conversion Box	11
Notes.	11
Parts List	13
Parts Diagram.	14
Assembly	17-24
Conversion Instructions for 16154.	25-27
Troubleshooting.	28-29

Repair Protection Agreements

Congratulations on making a smart purchase. Your new Kenmore® product is designed and manufactured for years of dependable operation. But like all products, it may require repair from time to time. That's when having a Repair Protection Agreement can save you money and aggravation. Purchase a Repair Protection Agreement now and protect yourself from unexpected hassle and expense.

Here's what the Repair Protection Agreement includes:

- Expert service** by our 10,000 professional repair specialists
- Unlimited service and no charge** for parts and labor on all covered repairs
- Product replacement** up to \$1500 if your covered product can't be fixed
- Discount of 25%** from regular price of service and related installed parts not covered by the agreement; also, 25% off regular price of preventive maintenance check
- Fast help by phone** – we call it Rapid Resolution – phone support from a Sears representative. Think of us as a “talking owner's manual.”

Once you purchase the Repair Protection Agreement, a simple phone call is all that it takes for you to schedule service. You can call anytime day or night, or schedule a service appointment online.

The Repair Protection Agreement is a risk-free purchase. If you cancel for any reason during the product warranty period, we will provide a full refund. Or, a prorated refund anytime after the product warranty period expires. Purchase your Repair Protection Agreement today!

Some limitations and exclusions apply.

**For prices and additional information call 1-800-827-6655.
Sears Installation Service**

For Sears professional installation of home appliances, garage door openers, water heaters, and other major home items, in the U.S.A. call **1-800-4-MY-HOME®**

WARRANTY

Kenmore Full Warranty

If this grill fails due to a defect in material or workmanship within one year from the date of purchase, call 1-800-4-MY-HOME® to arrange for free repair (or replacement if repair proves impossible).

Limited Warranty on Burners

For ten years from the date of purchase, any stainless steel burner that rusts through will be replaced free of charge. After the first year from the date of purchase, you pay for labor if you wish to have it installed.

All warranty coverage excludes ignitor batteries and grill part paint loss, discoloration or rusting, which are either expendable parts that can wear out from normal use within the warranty period, or are conditions that can be the result of normal use, accident or improper maintenance.

All warranty coverage is void if this grill is ever used for commercial or rental purposes.

All warranty coverage applies only if this grill is used in the United States.

This warranty gives you specific legal rights, and you may also have other rights which vary from state to state.

**Sears Brands Management Corporation,
Hoffman Estates, IL 60179**

USE AND CARE



- **NEVER** store a spare LP cylinder under or near the grill appliance or in an enclosed area.

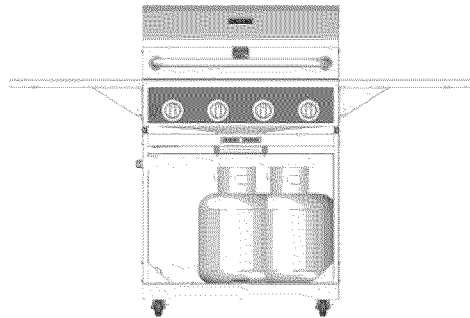

- Never fill a cylinder beyond 80% full.
- If the information in the two points above is not followed exactly, a fire causing death or serious injury may occur.
- An over filled or improperly stored cylinder is a hazard due to possible gas release from the safety relief valve. This could cause an intense fire with risk of property damage, serious injury or death.
- If you see, smell or hear gas escaping, immediately get away from the LP cylinder and grill appliance and call your fire department.

LP Cylinder

- The LP cylinder used with your grill must meet the following requirements:
- Use LP cylinders only with these required measurements: 12" (30.5cm) (diameter) x 18" (45.7 cm) (tall) with 20 lb. (9 kg.) capacity maximum.
- LP cylinders must be constructed and marked in accordance with specifications for LP cylinders of the U.S. Department of Transportation (DOT) or for Canada, CAN/CSA-B339, cylinders, spheres and tubes for transportation of dangerous goods. Transport Canada (TC). See LP cylinder collar for marking.
- LP cylinder valve must have:
- Type 1 outlet compatible with regulator or grill.
- Safety relief valve.
- UL listed Overfill Protection Device (OPD). This OPD safety feature is identified by a unique triangular hand wheel. **Use only LP cylinders equipped with this type of valve.**
- LP cylinder must be arranged for vapor withdrawal and include collar to protect LP cylinder valve. Always keep LP cylinders in upright position during use, transit or storage.

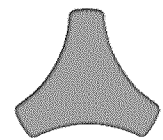

OPD Hand Wheel

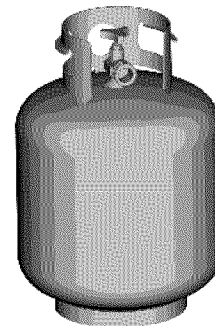

LP cylinder in upright position for vapor withdrawal

LP Tank Removal, Transport and Storage

- Turn OFF all control knobs and LP tank valve. Turn coupling nut counterclockwise by hand only - do not use tools to disconnect. Lift LP tank wire upward off of LP tank collar, then lift LP tank up and off of support bracket. Install safety cap onto LP tank valve. Always use cap and strap supplied with valve.

Failure to use safety cap as directed may result in serious personal injury and/or property damage.

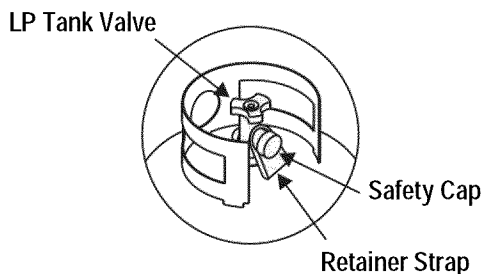

- A disconnected LP tank in storage or being transported must have a safety cap installed (as shown). Do not store an LP tank in enclosed spaces such as a carport, garage, porch, covered patio or other building. Never leave an LP tank inside a vehicle which may become overheated by the sun.
- Do not store an LP tank in an area where children play.

LP (Liquefied Petroleum Gas)

- LP gas is nontoxic, odorless and colorless when produced. **For Your Safety**, LP gas has been given an odor (similar to rotten cabbage) so that it can be smelled.
- LP gas is highly flammable and may ignite unexpectedly when mixed with air.

LP Cylinder Filling

- Use only licensed and experienced dealers.
- LP dealer **must purge new cylinder** before filling.
- Dealer should **NEVER** fill LP cylinder more than 80% of LP cylinder volume. Volume of propane in cylinder will vary by temperature.
- A frosty regulator indicates gas overfill. Immediately close LP cylinder valve and call local LP gas dealer for assistance.
- Do not release liquid propane (LP) gas into the atmosphere. This is a hazardous practice.
- To remove gas from LP cylinder, contact an LP dealer or call a local fire department for assistance. Check the telephone directory under "Gas Companies" for nearest certified LP dealers.



LP Tank Exchange

- Many retailers that sell grills offer you the option of replacing your empty LP tank through an exchange service. Use only those reputable exchange companies that inspect, precision fill, test and certify their cylinders. **Exchange your tank only for an OPD safety feature-equipped tank as described in the "LP Tank" section of this manual.**
- Always keep new and exchanged LP tanks in upright position during use, transit or storage.

- Leak test new and exchanged LP tanks **BEFORE** connecting to grill.

LP Tank Leak Test For your safety

- Leak test must be repeated each time LP tank is exchanged or refilled.
- Do not smoke during leak test.
- Do not use an open flame to check for gas leaks.
- Grill must be leak tested outdoors in a well-ventilated area, away from ignition sources such as gas fired or electrical appliances. During leak test, keep grill away from open flames or sparks.
- Use a clean paintbrush and a 50/50 mild soap and water solution. Brush soapy solution onto areas indicated by arrows in figure below. Leaks are indicated by growing bubbles.

	WARNING	
If "growing" bubbles appear do not use or move the LP tank. Contact an LP gas supplier or your fire department!		

- ▲ **Do not use household cleaning agents.** Damage to gas train components (valve/hose/regulator) can result.

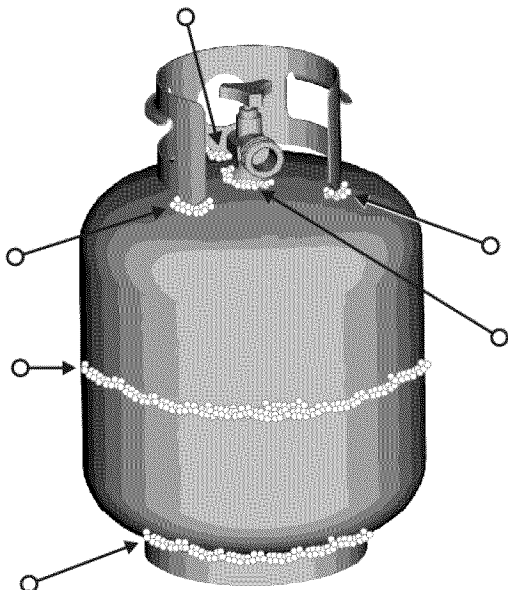

Connecting Regulator To The LP Tank

1. LP tank must be properly secured onto grill. (Refer to assembly section.)
2. Turn all control knobs to the OFF position.
3. Turn LP tank OFF by turning OPD hand wheel clockwise to a full stop.
4. Remove the protective cap from LP tank valve. Always use cap and strap supplied with valve.

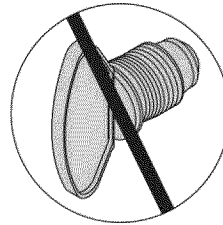
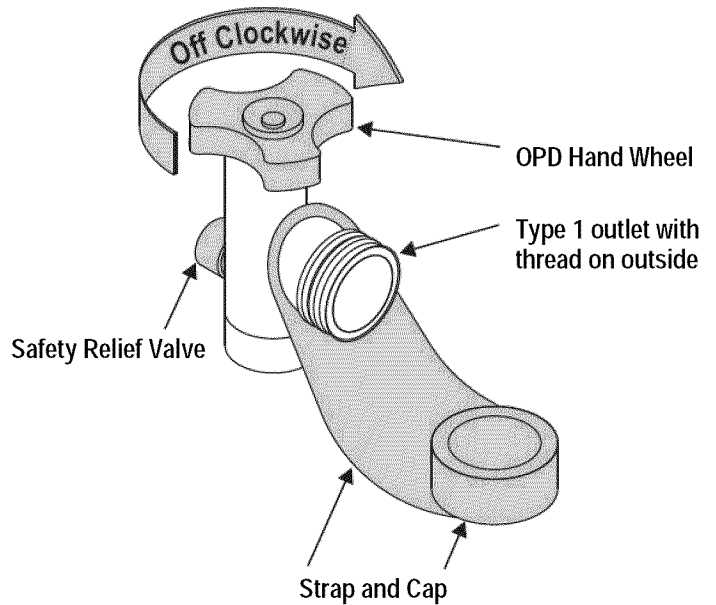

Do not insert a POL transport plug (plastic part with external threads) into the Type 1 tank valve outlet. It will defeat the Safety Relief Valve feature.

5. Hold regulator and insert nipple into LP tank valve. Hand-tighten the coupling nut, holding regulator in a straight line with LP tank valve so as not to crossthread the connection.

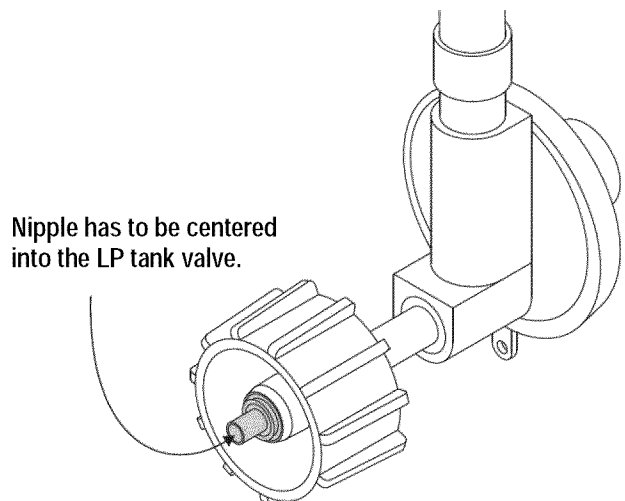

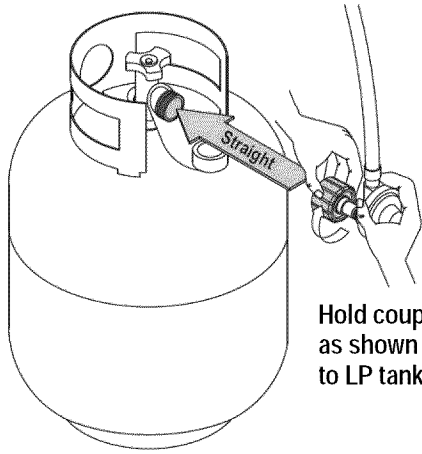

Hold coupling nut and regulator as shown for proper connection to LP tank valve.

- Turn the coupling nut clockwise and tighten to a full stop. The regulator will seal on the back-check feature in the LP tank valve, resulting in some resistance. **An additional one-half to three-quarters turn is required to complete the connection. Tighten by hand only – do not use tools.**

NOTE:

If you cannot complete the connection, disconnect regulator and repeat steps 5 and 6. If you are still unable to complete the connection, **do not use this regulator!** Call 1-800-482-0131 for assistance.

	DANGER	
<ul style="list-style-type: none"> Do not insert any tool or foreign object into the valve outlet or safety relief valve. You may damage the valve and cause a leak. Leaking propane may result in explosion, fire, severe personal injury, or death. 		

	WARNING	
<ul style="list-style-type: none"> Outdoor gas appliance is not intended to be installed in or on a boat. Outdoor gas appliance is not intended to be installed in or on an RV. Never attempt to attach this grill to the self-contained LP gas system of a camper trailer or motor home. Do not use grill until leak-tested. If a leak is detected at any time, STOP and call the fire department. If you cannot stop a gas leak, <i>immediately</i> close LP cylinder valve and call LP gas supplier or your fire department! 		

Leak Testing Valves, Hose and Regulator

- Turn all grill control knobs to OFF.
- Be sure regulator is tightly connected to LP tank.
- Completely open LP tank valve by turning OPD hand wheel counterclockwise. If you hear a *rushing sound*, turn gas off immediately. There is a major leak at the connection. **Correct before proceeding** by calling Sears for replacement parts at 1-800-4-MY-HOME®.
- Brush soapy solution onto areas where bubbles are shown in picture below:

▲ Never remove threaded orifice at end of valve.

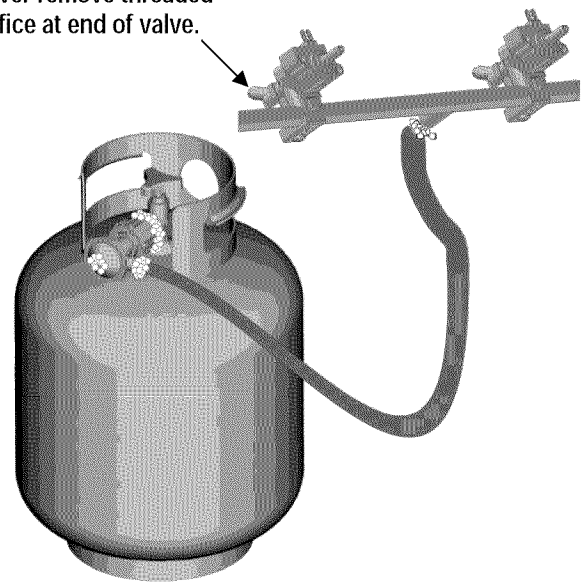

- If "growing" bubbles appear, there is a leak. Close LP tank valve immediately and retighten connections. **If leaks cannot be stopped do not try to repair.** Call Sears for replacement parts at 1-800-4-MY-HOME®.
- Always close LP tank valve after performing leak test by turning hand wheel clockwise.



WARNING



For Safe Use of Your Grill and to Avoid Serious Injury:

- Do not let children operate or play near grill.
- Keep grill area clear and free from materials that burn.
- Do not block holes in sides or back of grill.
- Check burner flames regularly.
- Use grill only in well-ventilated space. NEVER use in enclosed space such as carport, garage, porch, covered patio, or under an overhead structure of any kind.
- Do not use charcoal or ceramic briquets in a gas grill. *(Unless briquets are supplied with your grill.)*
- **Use grill at least 3 ft. from any wall or surface.** Maintain 10 ft. clearance to objects that can catch fire, or to sources of ignition such as pilot lights on water heaters, live electrical appliances, etc.

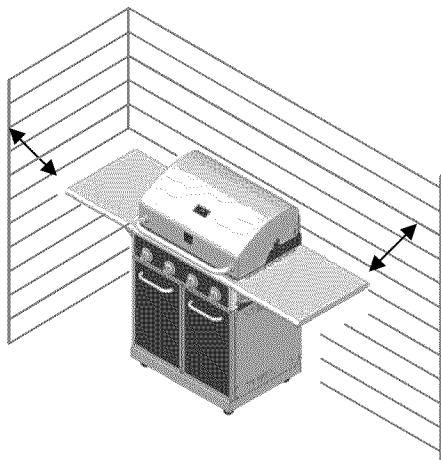

- **Apartment Dwellers:** Check with management to learn the requirements and fire codes for using an LP gas grill in your apartment complex. If allowed, use outside on the ground floor with a three (3) foot clearance from walls or rails. Do not use on or under balconies.
- **NEVER attempt to light burner with lid closed. A buildup of non-ignited gas inside a closed grill is hazardous.**
- **Never operate grill with LP cylinder out of correct position specified in assembly instructions.**
- **Always close LP cylinder valve and remove coupling nut before moving LP cylinder from specified operation position.**

Safety Tips

- ▲ Before opening LP cylinder valve, check the coupling nut for tightness.
- ▲ When grill is not in use, turn off all control knobs and LP cylinder valve.
- ▲ Never move grill while in operation or still hot.
- ▲ Use long-handled barbecue utensils and oven mitts to avoid burns and splatters.
- ▲ Maximum load for sideburner and side shelf is 10 lbs.
- ▲ The grease tray **must** be inserted into grill and emptied after each use. Do not remove grease tray until grill has completely cooled.
- ▲ Clean grill often, preferably after each cookout. If a bristle brush is used to clean any of the grill cooking surfaces, ensure no loose bristles remain on cooking surfaces prior to grilling. It is not recommended to clean cooking surfaces while grill is hot.
- ▲ If you notice grease or other hot material dripping from grill onto valve, hose or regulator, turn off gas supply at once. Determine the cause, correct it, then clean and inspect valve, hose and regulator before continuing. Perform a leak test.
- ▲ Keep ventilation openings in cylinder enclosure (grill cart) free and clear of debris.
- ▲ Do not store objects or materials inside the grill cart enclosure that would block the flow of combustion air to the underside of either the control panel or the firebox bowl.
- ▲ The regulator may make a humming or whistling noise during operation. This will not affect safety or use of grill.
- ▲ If you have a grill problem see the *"Troubleshooting Section"*.
- ▲ If the regulator frosts, turn off grill and LP cylinder valve immediately. This indicates a problem with the cylinder and it should not be used on any product. Return to supplier!



CAUTION



- **Putting out grease fires by closing the lid is not possible. Grills are well ventilated for safety reasons.**
- **Do not use water on a grease fire. Personal injury may result. If a grease fire develops, turn knobs and LP cylinder off.**
- **Do not leave grill unattended while preheating or burning off food residue on HI. If grill has not been regularly cleaned, a grease fire can occur that may damage the product.**

Ignitor Lighting the Grill

1. Read instructions before lighting your grill.
2. Open lid during lighting.
3. Open LP cylinder or natural gas valve.
4. Push any burner control knob in and turn the knob to the left to "HI" position. Keep pressing the knob until the burner is lit.

5. If ignition does not occur in 5 seconds, turn the burner control off, wait 5 minutes for gas to clear away, and repeat the lighting procedure.
 6. To light other burners, repeat step 4.
- NOTE: If ignitor does not work, follow Match Lighting instructions.

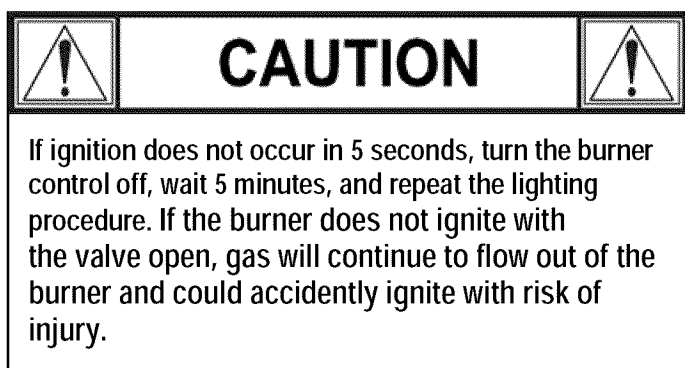
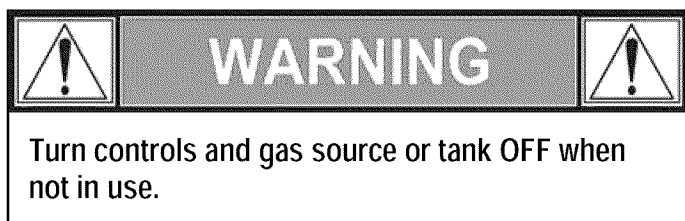

Match-Lighting

▲ Do not lean over grill while lighting.

1. Open lid during lighting.
2. Place match into match holder (hanging from side of cart). Light match, place into the firebox.
3. Push in and turn right knob to HIGH position. Be sure burner lights and stays lit.
4. Light other burners by pushing knob in and turning to HI position.

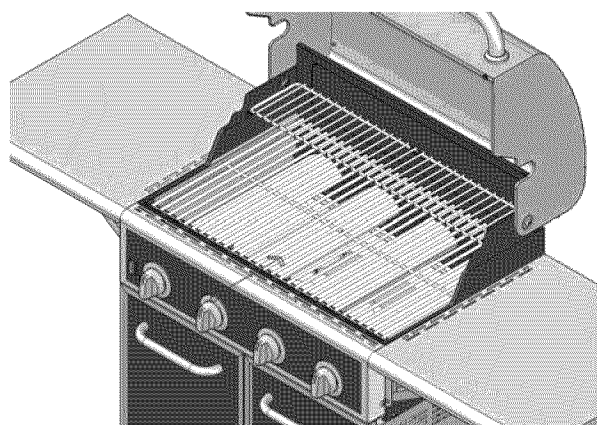

Burner Flame Check

- Remove cooking grates and heat diffusers. Light burners, rotate knobs from HIGH to LOW. You should see a smaller flame in LOW position than seen on HIGH. Perform burner flame check on sideburner, also. Always check flame prior to each use.

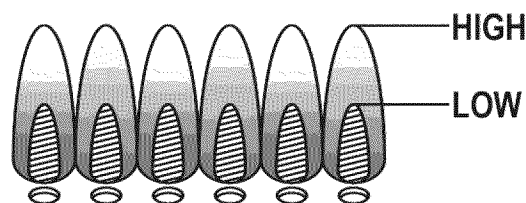

Turning Grill Off

- Turn all knobs to position. Turn LP cylinder off by turning hand-wheel clockwise to a full stop.

Ignitor Check

- Turn gas off at LP cylinder. Push the control knob in and turn the knob to the left to "HI" position. "Click" should be heard and spark seen each time between collector box or burner and electrode. See "Troubleshooting" if no click or spark.

Valve Check

- Important: Make sure gas is off at LP cylinder before checking valves. Knobs lock in OFF position. To check valves, first push in knobs and release, knobs should spring back. If knobs do not spring back, replace valve assembly before using grill. Turn knobs to LOW position then turn back to OFF position. Valves should turn smoothly.

Hose Check

- Before each use, check to see if hoses are cut or worn. Replace damaged hoses before using grill. Use only identical replacement part valve/hose/regulator as specified in the Parts List of this Use and Care Guide.

General Grill Cleaning

- Do not mistake brown or black accumulation of grease and smoke for paint. Interiors of gas grills are not painted at the factory (and should never be painted). Apply a strong solution of detergent and water or use a grill cleaner with scrub brush on insides of grill lid and bottom. Rinse and allow to completely air dry. Do not apply a caustic grill/oven cleaner to painted surfaces.
- Plastic parts: Wash with warm soapy water and wipe dry. Do not use citrisol, abrasive cleaners, degreasers or a concentrated grill cleaner on plastic parts. Damage to and failure of parts can result.
- Porcelain surfaces: Because of glass-like composition, most residue can be wiped away with baking soda/water solution or specially formulated cleaner. Use nonabrasive scouring powder for stubborn stains.
- Painted surfaces: Wash with mild detergent or nonabrasive cleaner and warm soapy water. Wipe dry with a soft nonabrasive cloth.

- Stainless steel surfaces:** To maintain your grill's high quality appearance, wash with mild detergent and warm soapy water and wipe dry with a soft cloth after each use. Baked-on grease deposits may require the use of an abrasive plastic cleaning pad. Use only in direction of brushed finish to avoid damage. Do not use abrasive pad on areas with graphics.
- Cooking surfaces:** If a bristle brush is used to clean any of the grill cooking surfaces, ensure no loose bristles remain on cooking surfaces prior to grilling. It is not recommended to clean cooking surfaces while grill is hot.



SPIDER ALERT!

SPIDER AND WEBS
INSIDE BURNER TUBE

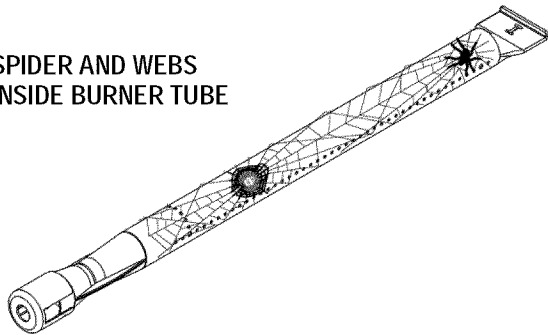

If you notice that your grill is getting hard to light or that the flame isn't as strong as it should be, take the time to check and clean the burner tubes.

Spiders or small insects have been known to create "flashback" problems. The spiders spin webs, build nests and lay eggs in the grill's burner tubes obstructing the flow of gas to the burner. The backed-up gas can ignite in the burner tube behind the control panel. This is known as a flashback and it can damage your grill and even cause injury.

To prevent flashbacks and ensure good performance the burner and burner tube assembly should be removed from the grill and cleaned before use whenever the grill has been idle for an extended period.

Storing Your Grill

- Fold the two shelves.
- Clean cooking grates.
- Store in dry location.
- When LP cylinder is connected to grill, store outdoors in a wellventilated space and out of reach of children.
- Cover grill if stored outdoors. Choose from a variety of grill covers offered by manufacturer.
- Store grill indoors ONLY if LP cylinder is turned off and disconnected, removed from grill and stored outdoors.
- When removing grill from storage, follow "Cleaning the Burner Assembly" instructions before starting grill.

Cleaning the Burner Assembly

Follow these instructions to clean and/or replace parts of burner assembly or if you have trouble igniting grill.

1. Turn gas off at control knobs and LP cylinder.
2. Remove cooking grates and heat diffusers.
3. Remove R pins from rear of burners.
4. Carefully lift each burner up and away from valve openings.

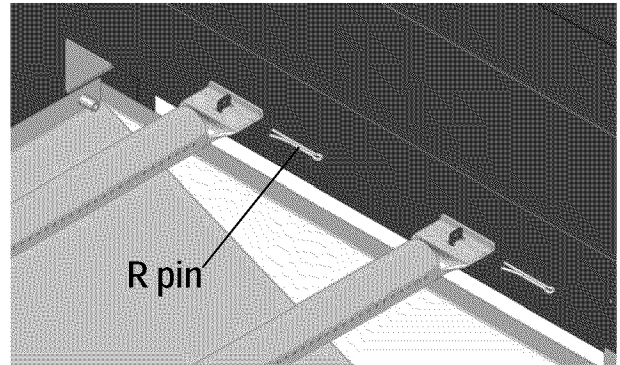

We suggest three ways to clean the burner tubes. Use the one easiest for you.

(A) Bend a stiff wire (a light weight coat hanger works well) into a small hook. Run the hook through each burner tube several times.



(B) Use a narrow bottle brush with a flexible handle (do not use a brass wire brush), run the brush through each burner tube several times.

(C) **Wear eye protection:** Use an air hose to force air into the burner tube and out the burner ports. Check each port to make sure air comes out each hole.

5. Wire brush entire outer surface of burner to remove food residue and dirt.
6. Clean any blocked ports with a stiff wire such as an open paper clip.
7. Check burner for damage, due to normal wear and corrosion some holes may become enlarged. If any large cracks or holes are found replace burner.

VERY IMPORTANT: Burner tubes must reengage valve openings.

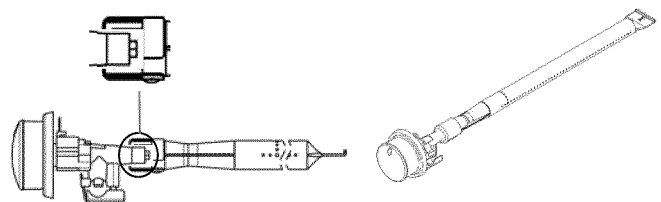

Correct burner-to-valve engagement

Indirect Cooking

Poultry and large cuts of meat cook slowly to perfection on the grill by indirect heat. Place food over unlit burner(s); the heat from lit burners circulates gently throughout the grill, cooking meat or poultry without the touch of a direct flame.

This method greatly reduces flare-ups when cooking extra fatty cuts because there is no direct flame to ignite the fats and juices that drip during cooking.

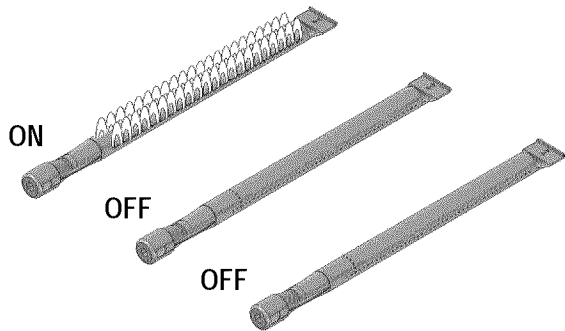

1 Burner Cooking

Cook with direct or indirect heat.
Best for smaller meals or foods.
Consumes less fuel.

Indirect Cooking Instructions

- Always cook with the lid closed.
- Due to weather conditions, cooking times may vary. During cold and windy conditions the temperature setting may need to be increased to insure sufficient cooking temperatures.
- Place food over unlit burner(s)

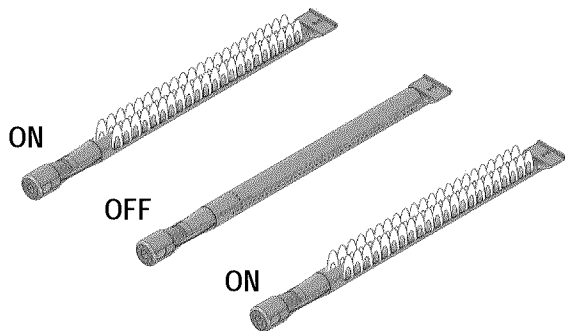

2 Burner Cooking

Great indirect cooking on low.
Produces slow, even heating.
Ideal for slow roasting and baking.

Food Safety

Food safety is a very important part of enjoying the outdoor cooking experience. To keep food safe from harmful bacteria, follow these four basic steps:

Clean: Wash hands, utensils, and surfaces with hot soapy water before and after handling raw meat and poultry.

Separate: Separate raw meats and poultry from ready-to-eat foods to avoid cross contamination. Use a clean platter and utensils when removing cooked foods.

Cook: Cook meat and poultry thoroughly to kill bacteria. Use a

thermometer to ensure proper internal food temperatures.

Chill: Refrigerate prepared foods and leftovers promptly.

For more information call: USDA Meat and Poultry Hotline at 1-800-535-4555 (In Washington, DC (202) 720-3333, 10:00 am-4:00 pm EST).

How To Tell If Meat Is Grilled Thoroughly

- Meat and poultry cooked on a grill often browns very fast on the outside. Use a meat thermometer to be sure food has reached a safe internal temperature, and cut into food to check for visual signs of doneness.
- Whole poultry should reach 180° F; breasts, 170° F. Juices should run clear and flesh should not be pink.
- Hamburgers made of any ground meat or poultry should reach 160° F, and be brown in the middle with no pink juices. Beef, veal and lamb steaks, roasts and chops can be cooked to 145° F. All cuts of pork should reach 160° F.
- NEVER partially grill meat or poultry and finish cooking later. Cook food completely to destroy harmful bacteria.
- When reheating takeout foods or fully cooked meats like hot dogs, grill to 165° F, or until steaming hot.

WARNING: To ensure that it is safe to eat, food must be cooked to the minimum internal temperatures listed in the table below.

USDA* Recommended Safe Minimum Internal Temperatures	
Beef, Veal, Lamb and Pork – Whole Cuts**	145° F
Fish	145° F
Beef, Veal, Lamb and Pork – Ground	160° F
Egg Dishes	160° F
Turkey, Chicken & Duck – Whole, Pieces & Ground	165° F

* United States Department of Agriculture

**Allow meat to rest three minutes before carving or consuming.

Natural Gas Conversion Kit

To purchase a Natural Gas Conversion Kit call Sears at 1-800-4-MY-HOME[®]

Natural gas conversion kit

Kenmore Model # 10478

(Manufacturer Part No.: 2818-2T-KIT)

Your grill can be converted to natural gas with this conversion kit by a qualified gas technician only. In order to convert this grill the technician will need this conversion kit.

The kit contains orifices for various grill models. Please select the orifices as listed below and discard the rest. Follow the conversion instruction provided with the kit.

Model	Main Burner 1.37 mm
	
148.16154211	4
148.16154211	
148.16154211	

12 ft. extension hose with 3/8 in. ID (inner diameter)

If converting the grill to natural gas, the technician in most cases will need this 12 ft. extension hose with 3/8" ID (inner diameter), which is included in the natural gas conversion kit.



Natural Gas Connection Preparation:

1. Turn off gas supply, and then remove cap on gas supply side.
2. Recommended: Install a shut-off valve on gas supply side before installing the socket.
3. Socket should be installed by an authorized technician in accordance with the national fuel gas code (NFPA 54/ANSI223.1).
4. Before inserting plug, turn on gas supply and leak test all connections including the stem of the shut-off valve and the opening of the socket. For best results, use an ammonia-free soap & water solution.

Operating Instructions:

1. To connect, push back socket sleeve.

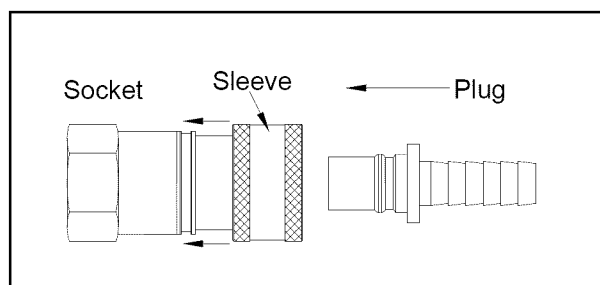

2. Insert plug and release sleeve.
3. Push plug until sleeve snaps forward. (Gas will flow automatically. Failure to connect plug properly to socket will inhibit gas flow to the appliance.)

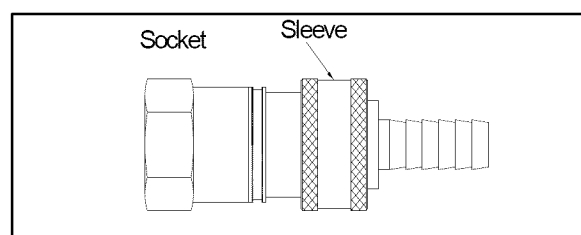

To disconnect

1. Pull Sleeve back. Pull plug out of socket. (Gas is automatically shut off.)
2. Close shut-off valve or turn off gas supply, and replace dust caps on socket and plug.

Gas Requirements

LP Gas

Now that your grill is converted to Natural Gas use, it is set for 7-inch water column (WC) pressure, and cannot be used with Propane Gas. The factory-supplied regulator and hose must be used with a 20-lb. LP gas tank.

Natural Gas

If your grill is for Natural Gas, it is set for a 7-in. water column (WC) and is for use with Natural Gas only. Gas pressure is affected by gas line size and the length of gas line run from house gas line. Follow the recommendations in the chart below.

From House to Grill	
Distance	Tubing Size
Up to 25 ft.	3/8 in. diameter
26-50 ft.	1/2 in. diameter
51-100 ft.	2/3 of the run: 3/4 in. diameter 1/3 of the run :1/2 in. diameter
Over 101 ft.	3/4 in. diameter

CAUTION:

If low flames or burner problems are witnessed after converting from LPG to NG, the natural gas lines may not be large enough. Refer to the "From House to Grill" chart on page 12 for natural gas supply line specifications. Please contact a plumber to assure proper pressure at 7 in. water column.

Do not return your grill to the store.

Excess Flow Control and Low Heat

The propane regulator assembly incorporates an excess flow device designed to supply the grill with sufficient gas flow under normal conditions yet control excess gas flow. Rapid changes in pressure can trigger the excess flow device providing a low flame and low temperature. If the tank valve is turned open to allow gas flow while a burner valve is open, the surge of pressure will cause the device to activate. The device will remain closed until the pressure is equalized. This should occur within 5 seconds.

To ensure this does not cause difficulty in lighting the grill, follow these instructions:

1. Make sure all burner valves are "OFF".
2. Open the tank valve and wait 5 seconds.
3. Light the burners one at a time following the lighting instructions.

Helpful Care and Maintenance Hints

Before grilling, pre-heat grill for 15 minutes on "HI" with hood down. To avoid uncontrolled flare-ups or grease fires, grill meats with hood open. Close hood if meats are thick or weather is cold, or if you are using a rotisserie or indirect cooking.

Always protect your hand with a pot holder or cooking glove when coming into contact with a hot surface.

Hood up when grilling meats, especially chicken. Hood down when indirect or rotisserie cooking.

NEVER leave your grill unattended while cooking.

After use, close hood, turn burners to HI for 15 min. for self-cleaning, grease burn off.

Care and Maintenance Time Table Chart

Grill Item	Frequency Based on Normal Use	Cleaning Method
Painted surface	Twice yearly	Car wax
Stainless surface	Twice yearly	Stainless cleaner
All grates	After each use	Burn off and wipe
Stainless grates	15 days	Wire brush/ Dishwasher safe
Porcelain grates	15 days	Scrub pad soapy water /Dishwasher safe
Burner heat tents	30 days	Wire brush
Burners	90 days	Wire brush
Burner box interior	120 days	Interior grill cleaning products (available at Sears)

PARTS LIST

Key	Qty	Description	Manufacturer Part #
1	1	HOOD HANDLE	2818-2T-6200
2	2	HANDLE BASE	RB2818C-00-4001
3	2	SCREW	1/4-20×5/8 in.
4	4	RUBBER GASKET	3219B-8083
5N	1	HOOD	2818-2T-6000
6	2	SCREW	5/16-18×3/4 in.
7	2	BUSHING	2818-2T-0001
8	2	FLANGE NUT	5/16-18
9	1	TEMPERATURE GAUGE	2818-2T-A301
10	1	WASHER,TEMPERATURE GAUGE	2518SL-6002
11	1	NUT	5/16-18
12	4	HEAT DIFFUSER	2818-2T-2007
13	2	COOKING GRIDS	2818-2T-2001
14	1	WARMING RACK	2818-2T-2002
15-1	1	IGNITION PIN (MAIN BURNER)	2818-2T-A500-4/1
15-2	1	IGNITION PIN (MAIN BURNER)	2818-2T-A500-4/2
15-3	1	IGNITION PIN (MAIN BURNER)	2818-2T-A500-4/3
15-4	1	IGNITION PIN (MAIN BURNER)	2818-2T-A500-4/4
16	4	PIN	1.6×30
17	4	MAIN BURNER	SH3118B-2004
18	16	SCREW	5/32-32×3/8 in.
19N	1	BURNER BOX	2818-2T-2000
20	1	WIND SHIELD	2818-2T-2004
21N	1	RIGHT WING TABLE ASSE	2818-2T-5000-2
21N-1	1	RIGHT WING TABLE	2818-2T-5100-2
25	1	IGNITION SWITCH WIRE	2818-2T-A400
26N	1	MANIFOLD,MAIN BURNER	2818-2B-3200
27	1	LP GAS REGULATOR	SH3118B-3003
28	1	REAR PANEL	2818-2T-1002
29	1	RIGHT PANEL ASSEMBLY	2818-2T-1400-2
30	1	BEAM	2818-2T-1200
31	1	RIGHT ANGLE BRACKET	2818-2T-1700
32	2	CASTER,LOCKING	2518-3-8007
33	2	CASTER	2518-3-8008
34	1	WING-HEAD SCREW	1/4-20×2 in.
35	1	SCREW W/SHOULDER	5/32-32×3/8 in.
36	1	MATCH HOLDER	3019L-1710
37N-1	1	DOOR(R-BLACK)	2818-2T-8000
37N-2	1	DOOR(R-RED)	2818-2R-8000
37N-3	1	DOOR(R-STAINLESS STEEL)	2818-2S-8000
38N-1	1	DOOR(L-BLACK)	2818-2T-7000

Key	Qty	Description	Manufacturer Part #
38N-2	1	DOOR(L-RED)	2818-2R-7000
38N-3	1	DOOR(L-STAINLESS STEEL)	2818-2S-7000
39N	1	BOTTOM PANEL ASSEMBLY	2818-2B-1100
40	31	SCREW	3/16-24×3/8 in.
41	1	LEFT ANGLE BRACKET	2818-2T-1600
42	3	MAGNET	SH3118-1803
43	1	MAGNET HOUSING	2818-2T-1102
44	2	SCREW	5/32-32×3/8 in.
45	1	ELECTRICAL IGNITER	2818-2T-A600
45a	2	NUT	5/32-32
45b	1	BATTERY BOX	3218LT-00-8014
45c	2	SCREW	5/32-32×3/8 in.
46	1	IGNITER HOUSING	2818-2T-1302
47	1	LEFT PANEL ASSEMBLY	2818-2B-1300
48	1	DRIP TRAY SUPPORT	2818-2T-1500
49	1	DRIP TRAY	2818-2T-1001
50N	4	KNOB	2818-2B-3100
51	8	SCREW	M4×8
51a	1	SWITCH, LED	E3520-00-8015
52N	4	BEZEL	2818-2B-3003
53	4	SCREW	1/4-20×3/8 in.
54N-1	1	CONTROL BOX	2818-2B-3001
54N-2	1	CONTROL BOX	2818-2R-3001
54N-3	1	CONTROL BOX	2818-2S-3001
54a	1	LED LIGHT	2818-2B-8300
55N	1	LEFT WING TABLE ASSE	2818-2T-4000-2
55N-1	1	LEFT WING TABLE	2818-2T-4100-2
55N-2	2	PIN, 37 MM	6 X 37
55N-3	4	SUPPORT BAR	2818-2T-4004
55N-4	4	PIN, 43 MM	6 X 43
55N-5	4	VERTICAL BAR	2818-2T-4005
55N-6	6	COTTER PIN	1.6 X 10
55N-7	2	PIN, 68 MM	2818-2T-4008
55N-8	2	SHAFT, SIDE TABLE	2818-2T-4003

If you are missing hardware or have damaged parts after unpacking grill, call 1-800-482-0131 for replacement.

To order replacement parts after using grill, call 1-800-4-MY-HOME®

NOTE: Some grill parts shown in the assembly steps may differ slightly in appearance from those on your particular grill model. However, the method of assembly remains the same.

PARTS DIAGRAM

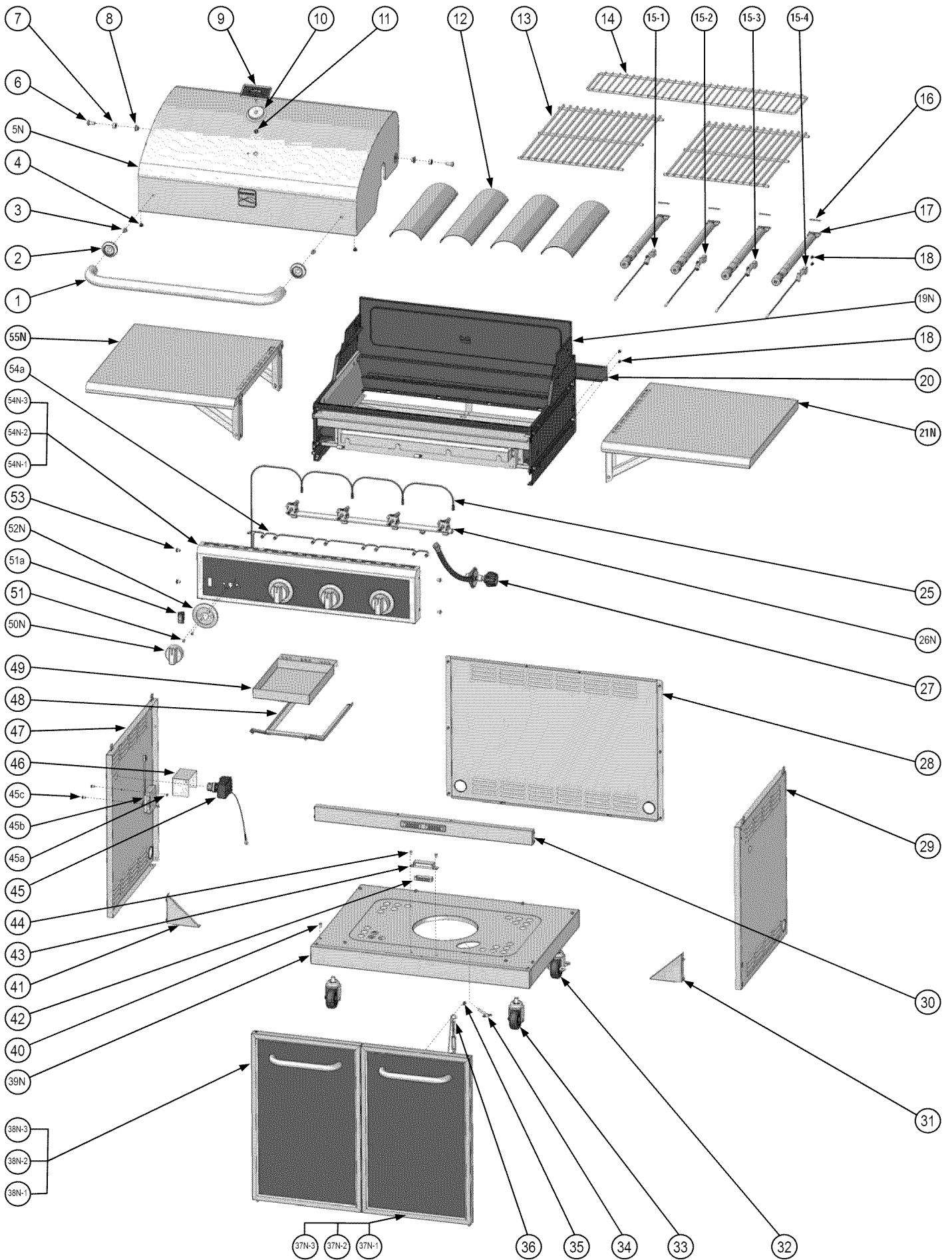

PARTS DIAGRAM

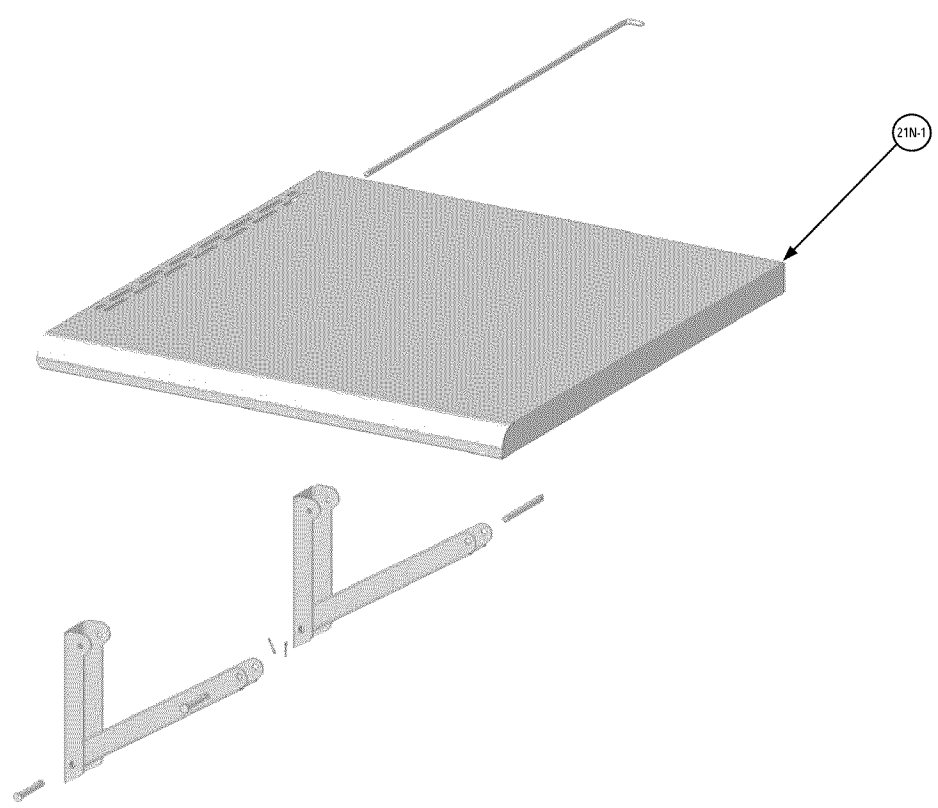
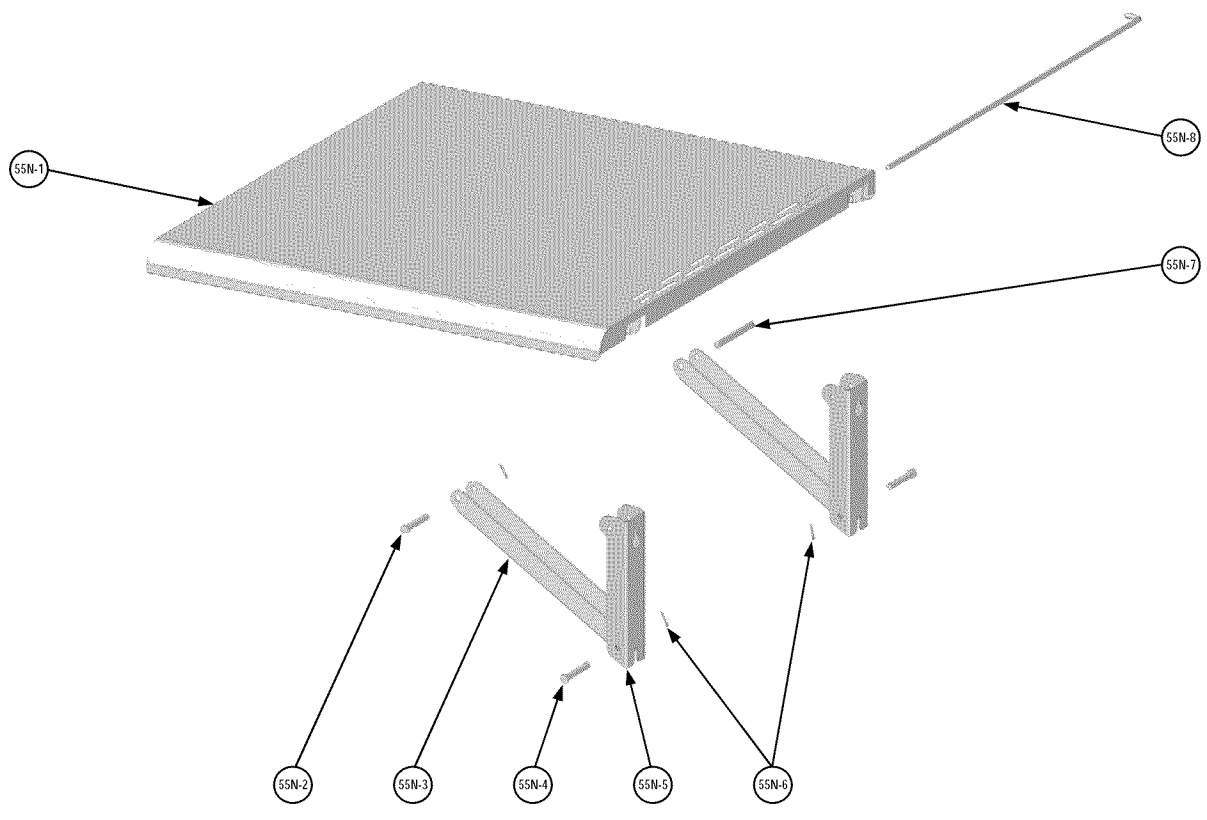

Wing Table - Expanded Parts Diagram



PARTS DIAGRAM

For Model 2818-2B / 2818-2R

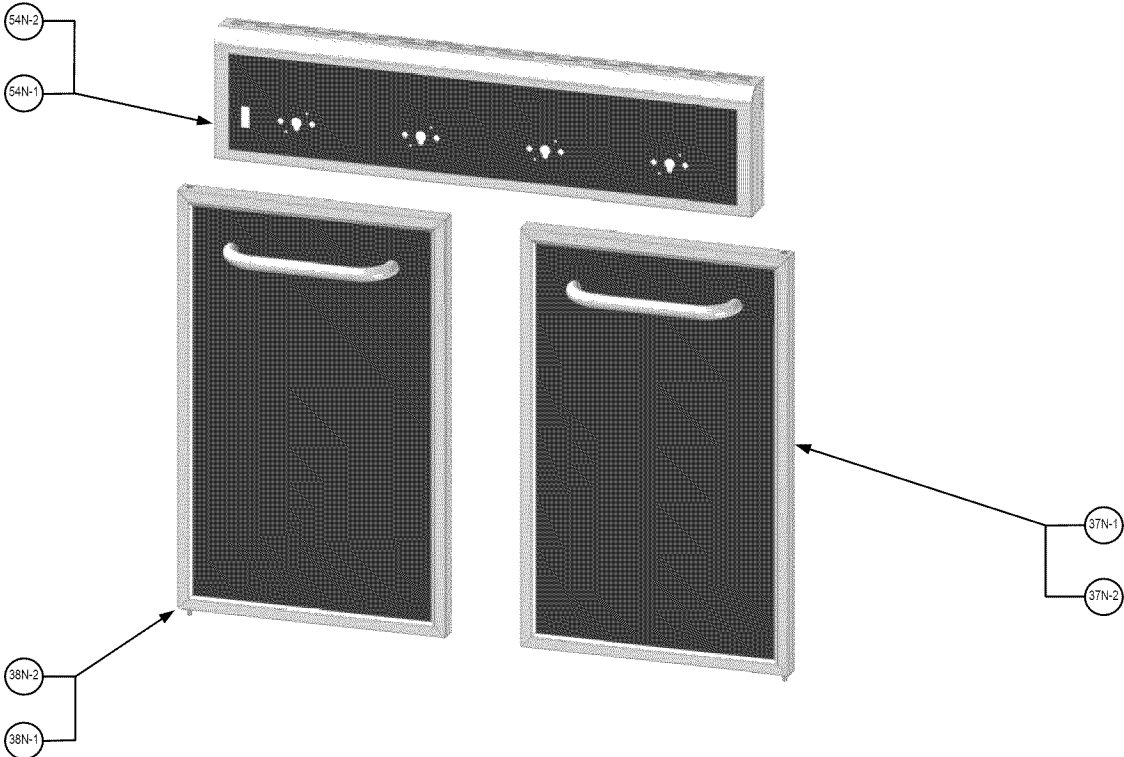

For Model 2818-2S

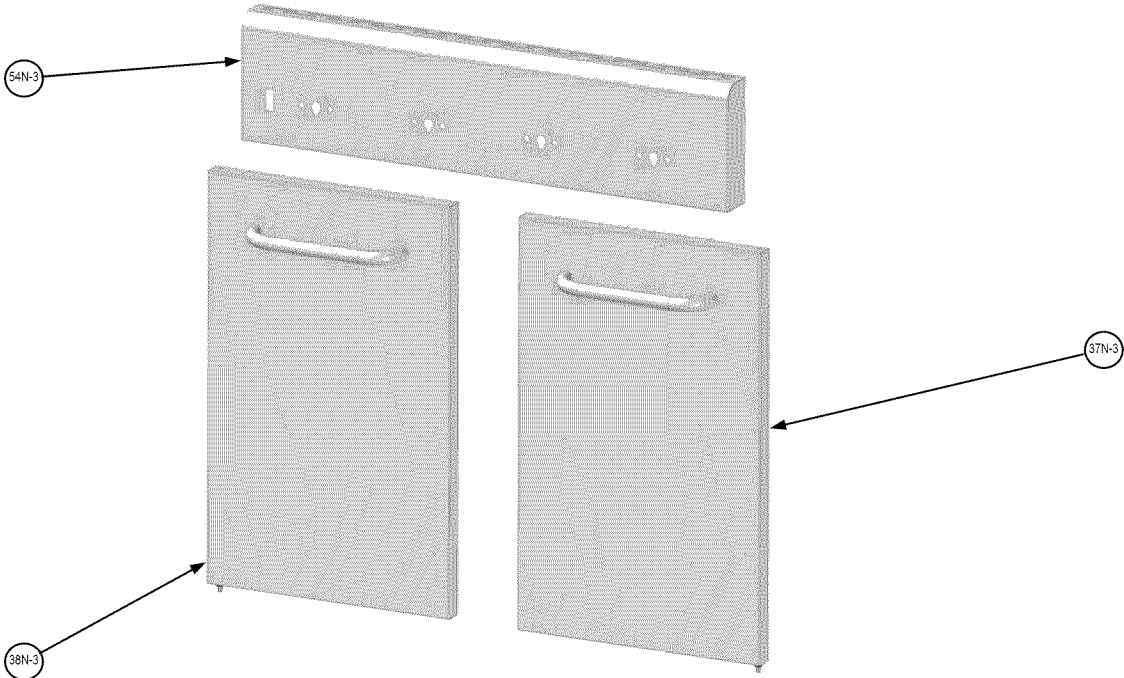

UNPACKING

After removing all parts and hardware pack from the top of the shipping box, and when the only part showing is the grill head, use a box cutting knife to slice down the sides of the box. Be careful of staples along shipping box edges.

Remove the corner supports from the box and the styrofoam side pieces from the grill head. Allow grill head to rest on cardboard until placing grill head on cart in Step 7.

Open grill lid and remove all packaged parts and packing material.

WARNING: Assemble the grill on a flat level surface. Compare the parts and hardware with the list and diagrams. Do not attempt assembly if any part is missing or damaged.

1

Insert the casters into the holes of the bottom panel, and then tighten with wrench from the hardware pack. When this process is completed, turn the bottom panel right side up. The two locking casters should be at the back of the grill.

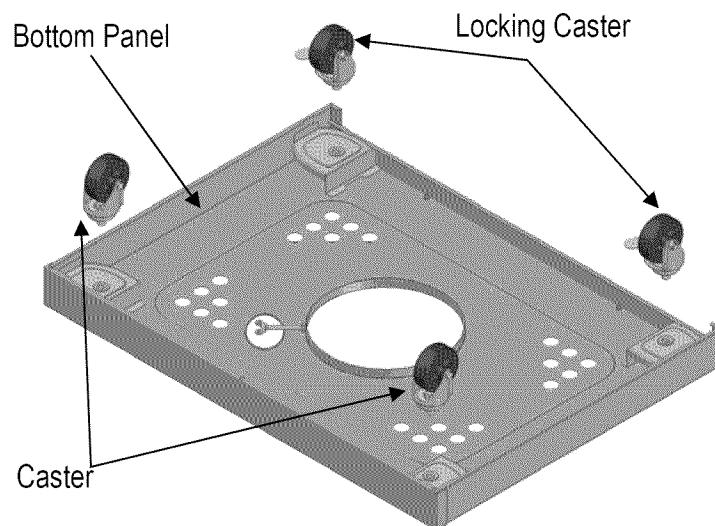

2

Loosen the two screws at the back of the bottom panel 3 to 4 turns.

Place the holes in the base of the rear panel over the two loosened screws and slide the panel to the left until it stops. Retighten the screws.

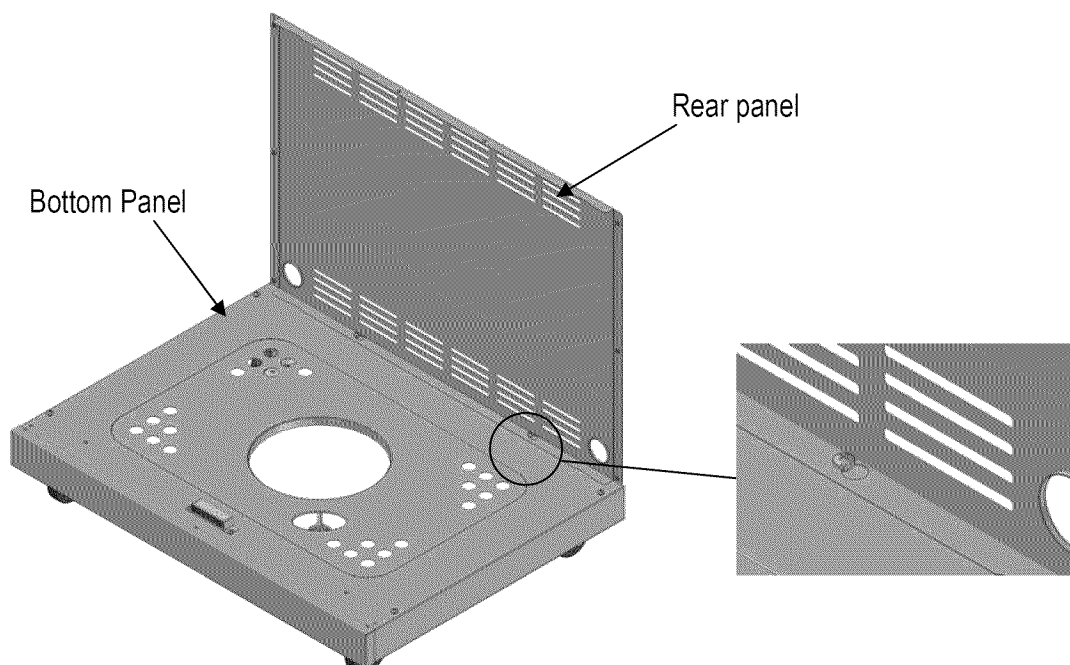

3

Loosen the 4 screws at the corners of the bottom panel 3 to 4 turns.

Place the holes in the base of each side panel over the loosened screws and slide the panel to the front until it stops. Retighten the screws.

Use six 3/16-24 x 3/8 in. screws to fasten the rear panel to side panels.

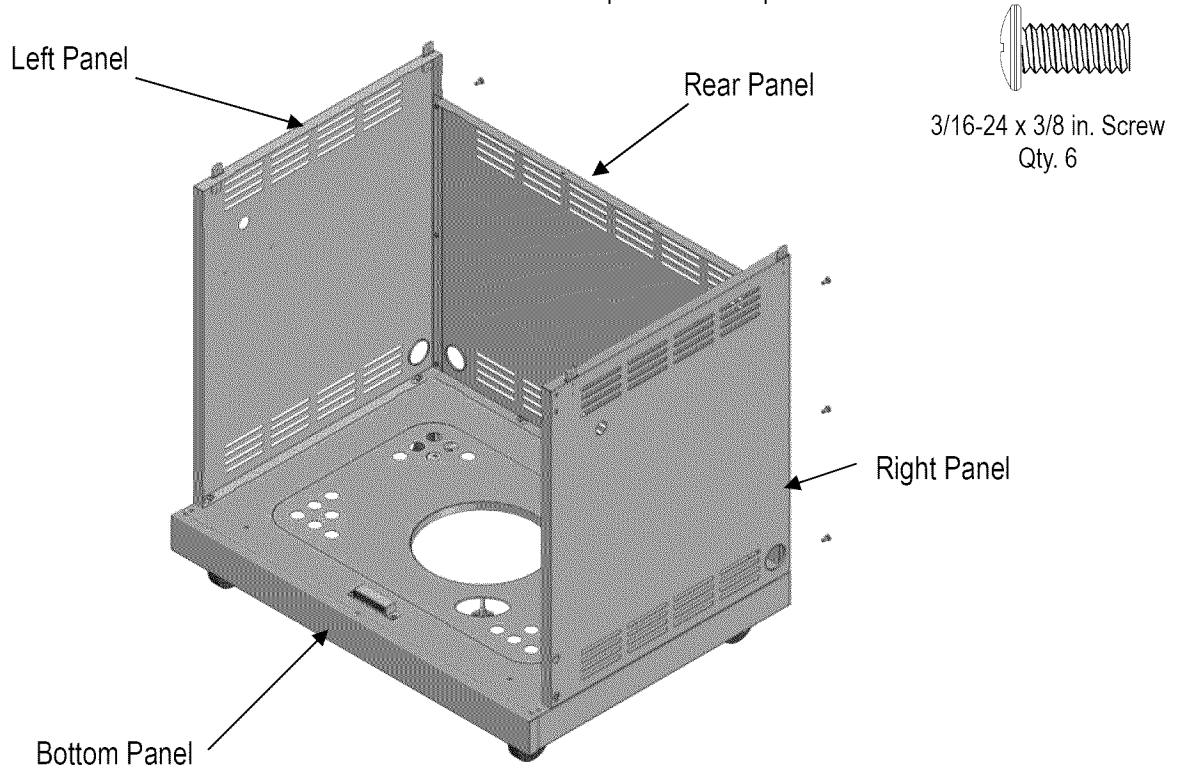

4

Remove the cap and nut from the electrical igniter. Use the nut to assemble the igniter and igniter housing to the left panel as shown. Screw cap onto igniter. Then install the battery box with two 5/32-32 x 3/8 in. screws and two 5/32 nuts to the left side panel.

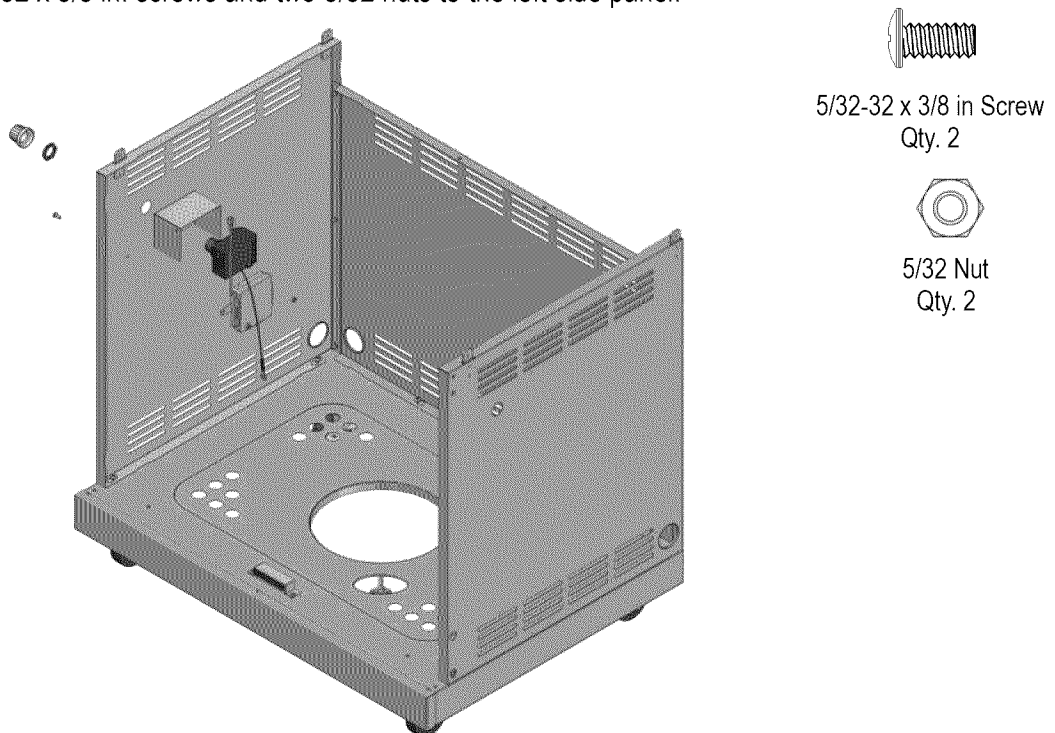

5

Loosen the two screws in the right and left angle brackets 3 to 4 turns.
Insert the screws through the 2 holes at the base of each side panel and slide the bracket down until it stops. Attach each bracket to the bottom panel with one 3/16-24 x 3/8 in. screw. Retighten the 4 loosened screws.

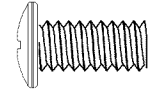
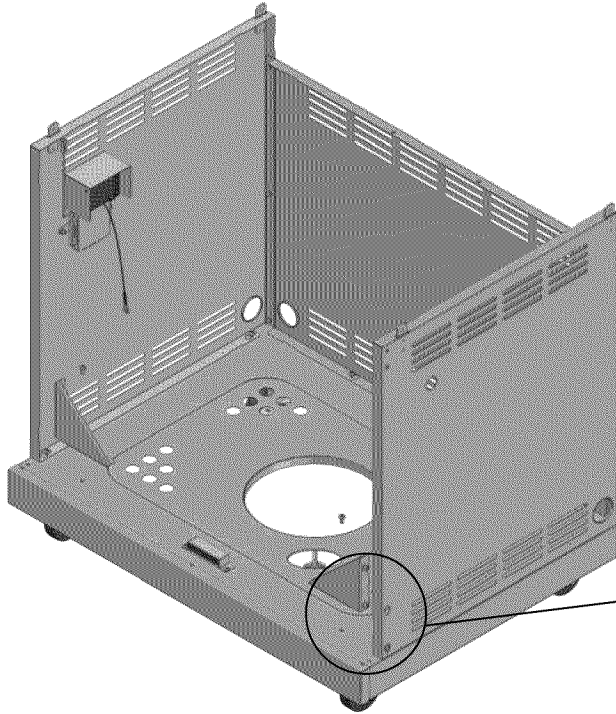

3/16-24 x 3/8 in. Screw
Qty. 2

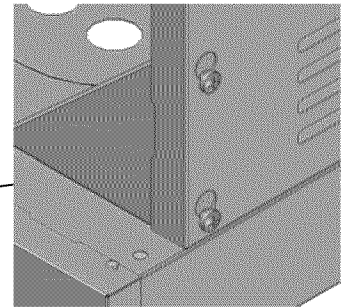

6

Attach the beam to side panels with four 3/16-24 x 3/8 in. screws as shown.

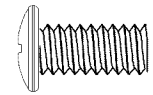
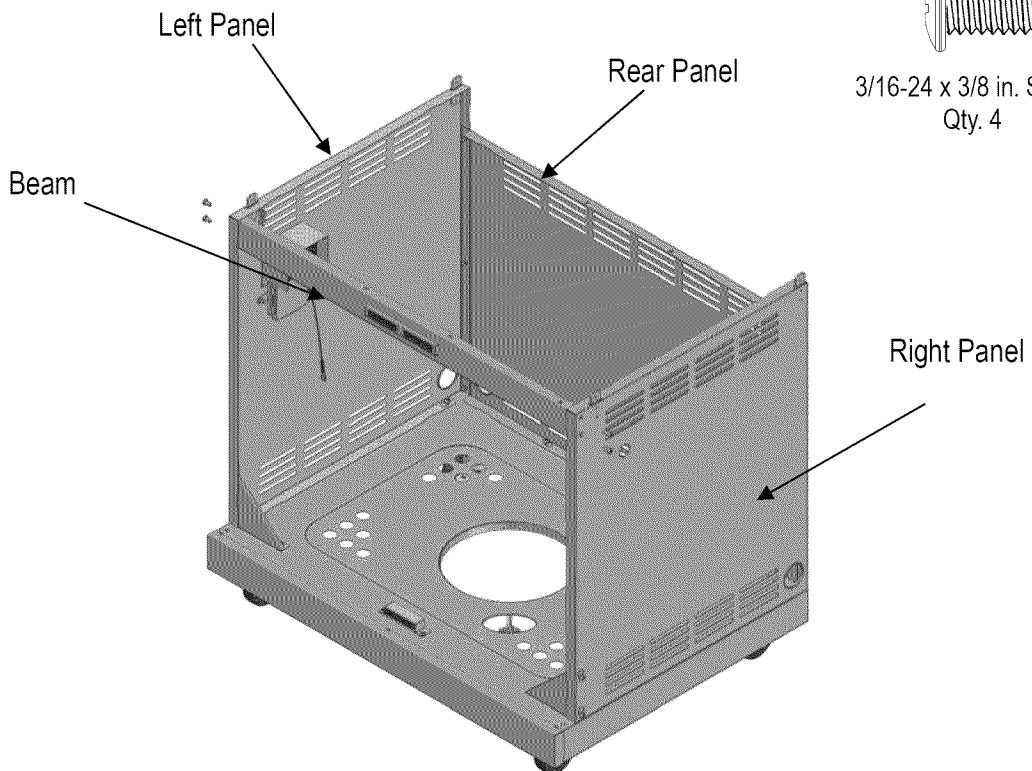

3/16-24 x 3/8 in. Screw
Qty. 4

7

Attach the drip tray support to the beam and rear panel with four 3/16-24 x 3/8 in. screws as shown. Note: Tabs at front attach beneath beam upper ledge.

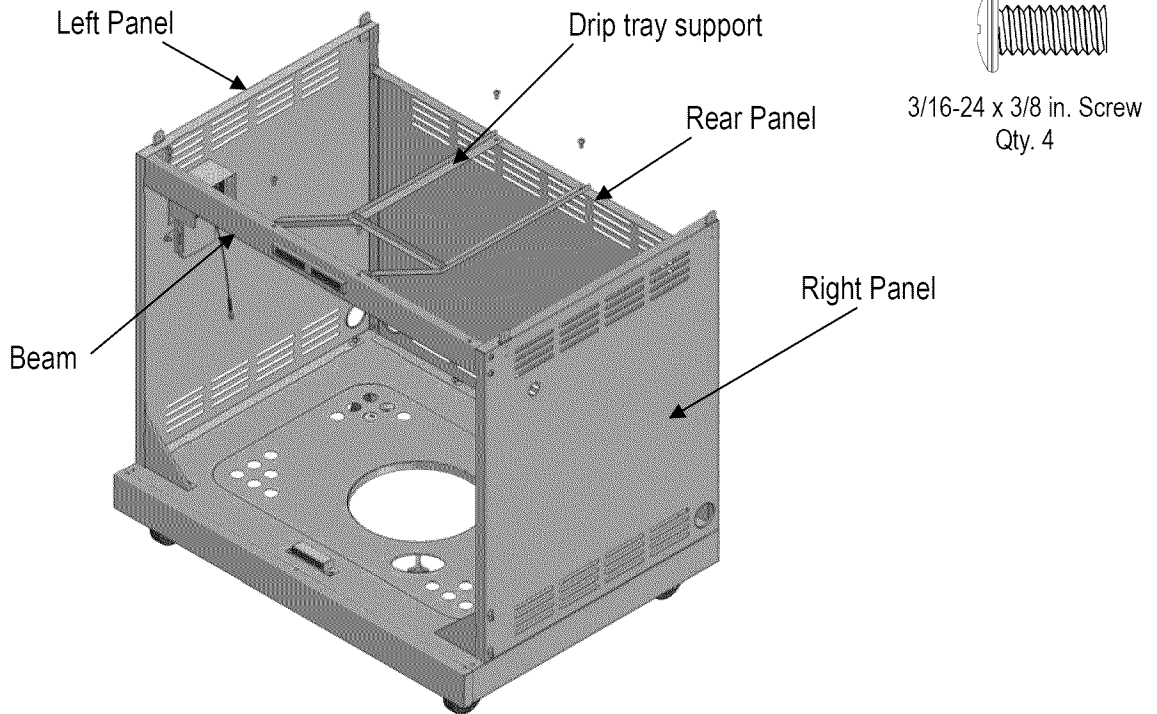
**8**

Grill Head Assembly

First, lock the two rear casters of the grill cart.

Locate the gas pressure regulator and igniter wires under the grill head control panel. Carefully cut the tie wrap(s) from the regulator hose. With the aid of an assistant, lift and place the grill head onto the cart, making sure that the regulator hose and igniter wires hang down into the cart. Align the corner holes at the base of the grill head with the holes in the corner tabs of the cart. Attach the grill head to the cart with four 3/16-24 x 3/8 in. screws.

WARNING: Do not lift grill head from sides. Grasp the grill head by the front control panel and rear panel to avoid pinching fingers when lowering grill head onto cart.

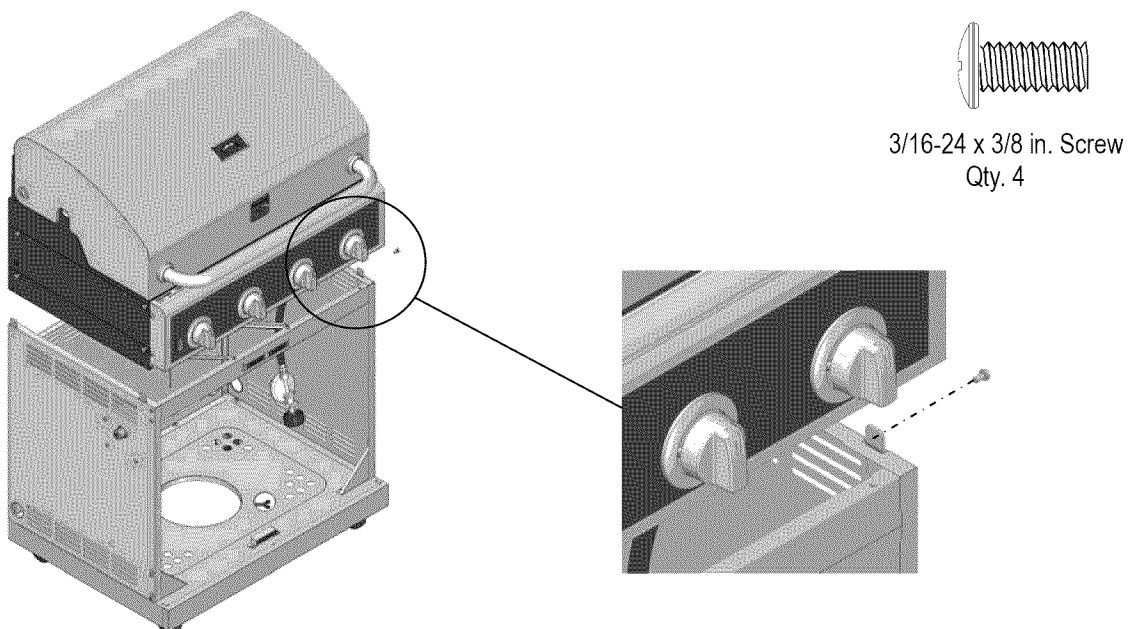

9

Connect the four burner ignition wires to the four sockets on the right side of the igniter. Connect the remaining wire to the remaining open socket.

Place the ground wire through the slots on the side panel as shown below. Loosen one control panel screw, install the ground wire onto the screw, and retighten it to make a good connection.

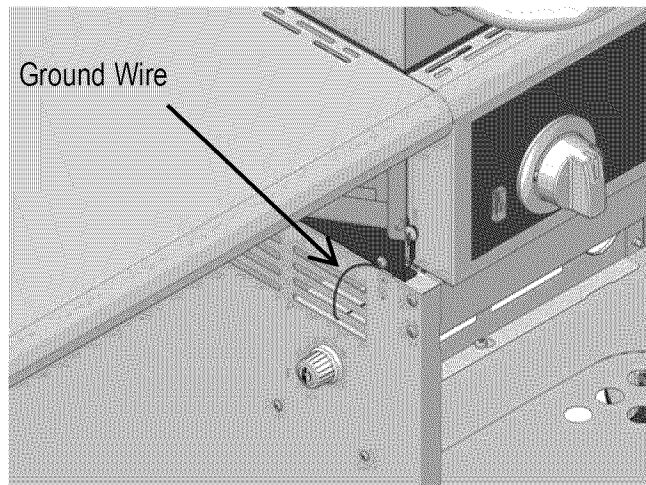
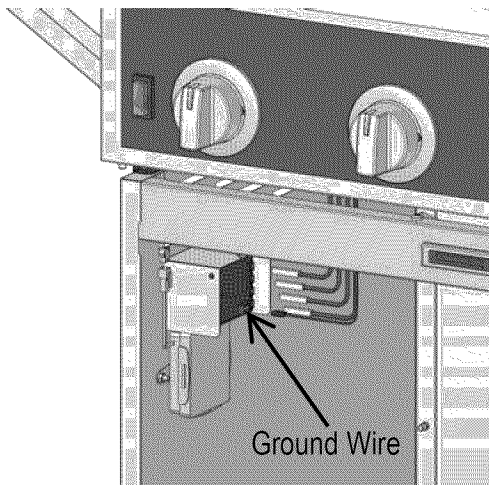
**10**

Install the doors

For each door, insert the bottom hinge pin into the hole in the bottom panel. Push up the top hinge pin located under the bottom of control panel to get it into the hinge hole in the door. If necessary, loosen screws on bottom panel magnet housing and adjust and retighten so that doors close securely.

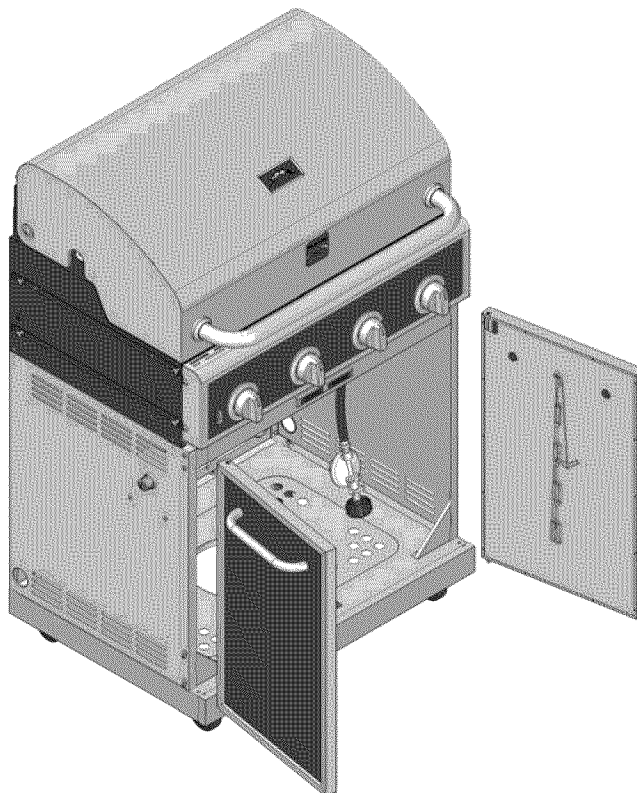

11

Lay one of the wing tables upside down, as shown. Lift up one of the support bars from the wing table support brackets, and fasten it to a vertical bar as shown, using a 43 mm pin and a cotter pin. Once the cotter pin is in place, bend the legs at right angles to lock it into place. Repeat for the other support bar.

Insert the side table shaft through the oblong hole at the back end of the wing table, through the holes in the support brackets and vertical bars. Once the shaft is fully inserted into the wing table, rotate it so that the short right angled end is no longer aligned with the oblong hole. It will stay in place.

Repeat these steps for the other wing table.

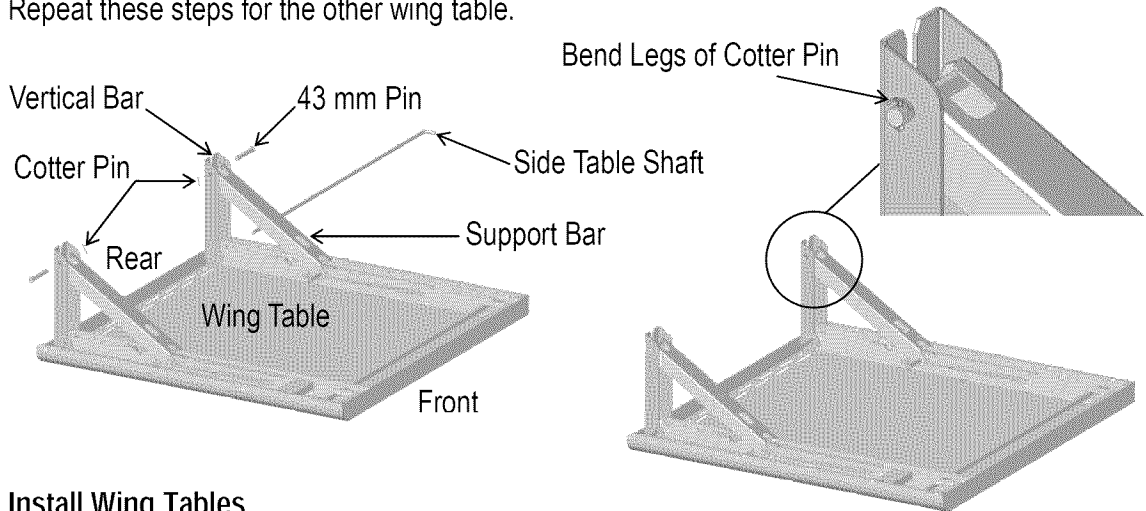

12

Install Wing Tables

Loosen the 4 screws (as shown) on each side of grill head 4 to 6 turns.

Slide the slots in each vertical bar over the loosened screws. Make sure the wing surface is flush with the control panel, then tighten the 4 loosened screws with a long screwdriver that has at least a 7 inch long shaft.

Note: Attach each wing so that the rounded edge faces front.

Slide slots over screws

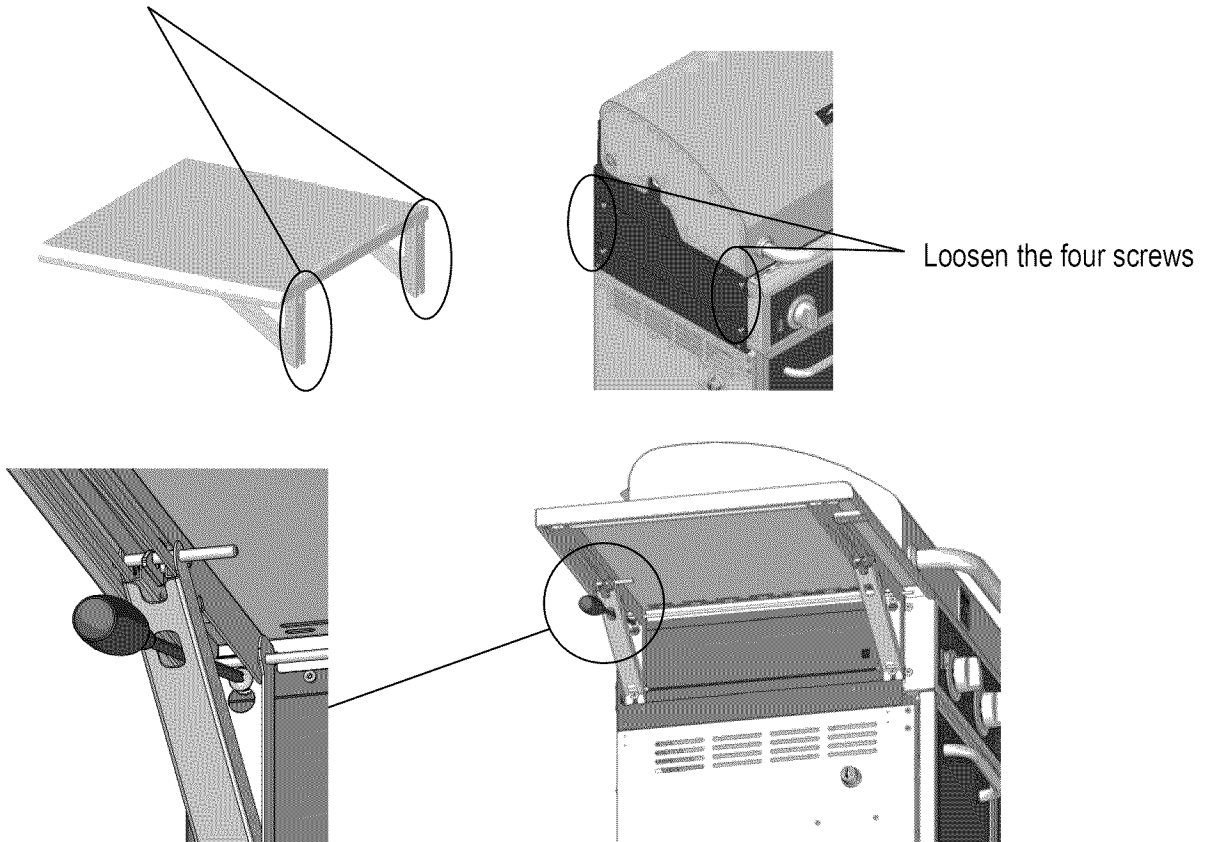

13 Wing Table Operation.

Pull the bar outwards to lower the wing table as shown.
To raise wing table, lift table up until wing mechanisms lock into place.

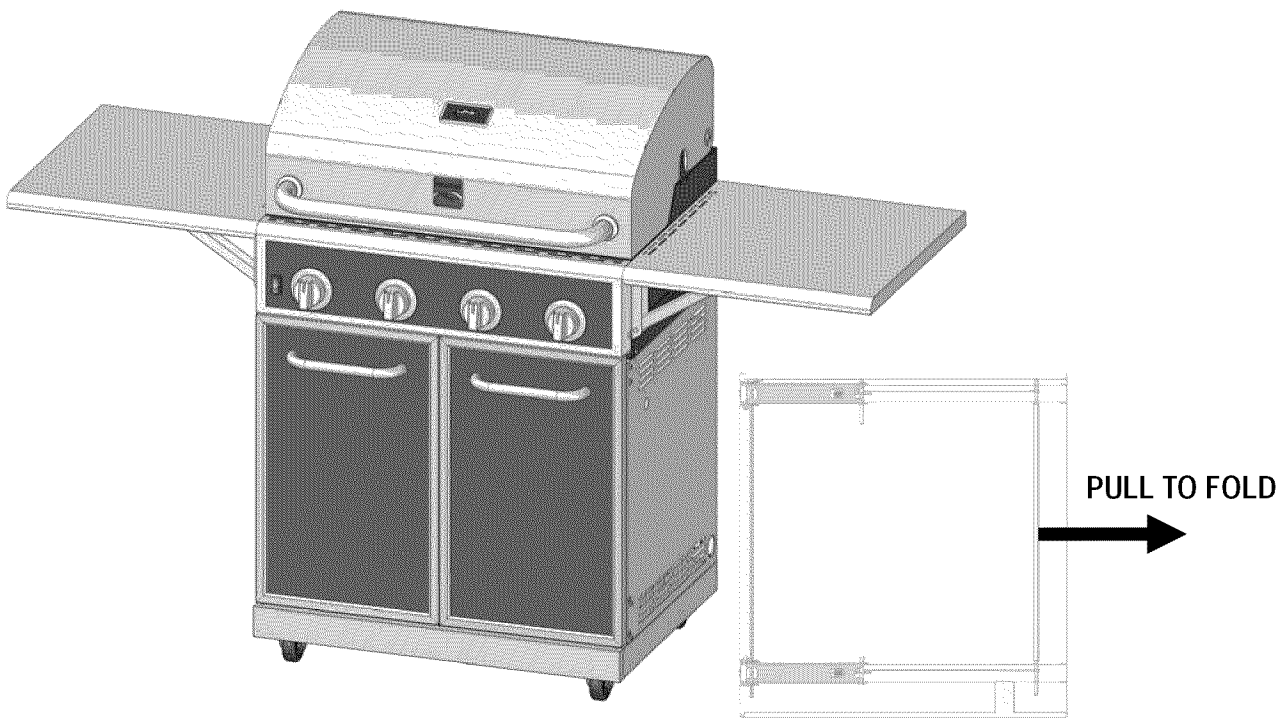

14 Slide the drip tray between the drip tray supports.

To lower wing table, press up on the front and back wing mechanism release levers.
To raise wing table, lift table up until wing mechanisms lock into place.

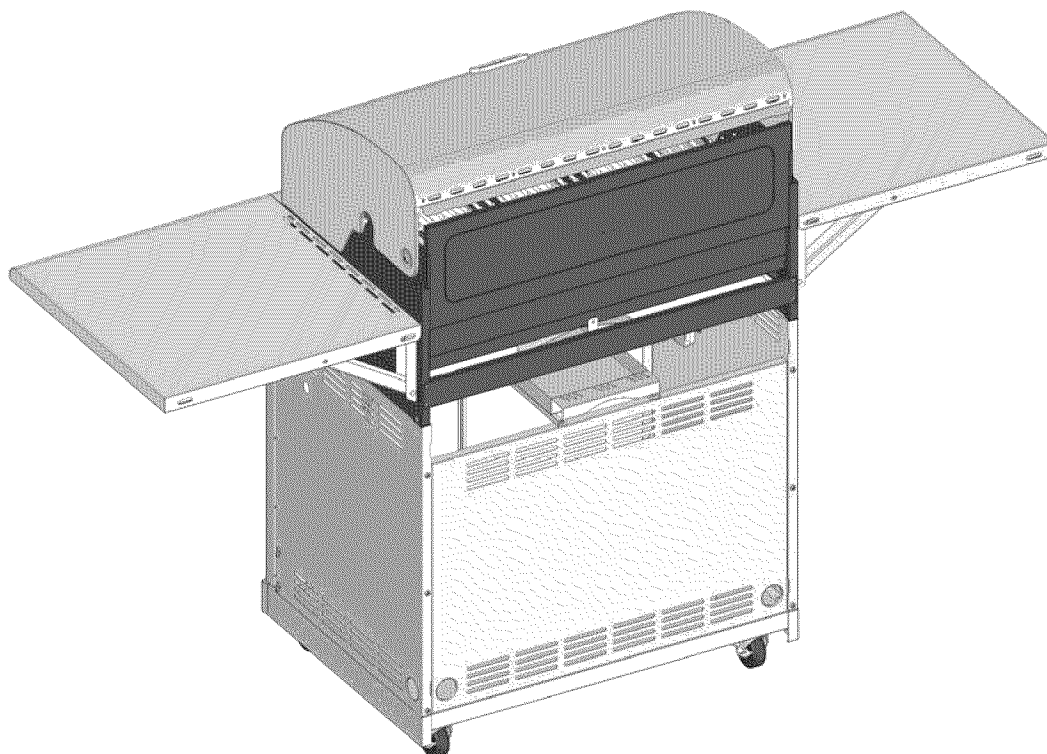

15

Position the four heat diffusers, two cooking grids and the warming rack into place.

Note: The diffuser edges fit into slots at front and back of burner box.

Remove battery cap and insert AA battery with positive pole facing out. Replace cap.

Open the battery box and install four AAA batteries into the box with correct polarity. Then couple the LED light wire with the battery box.

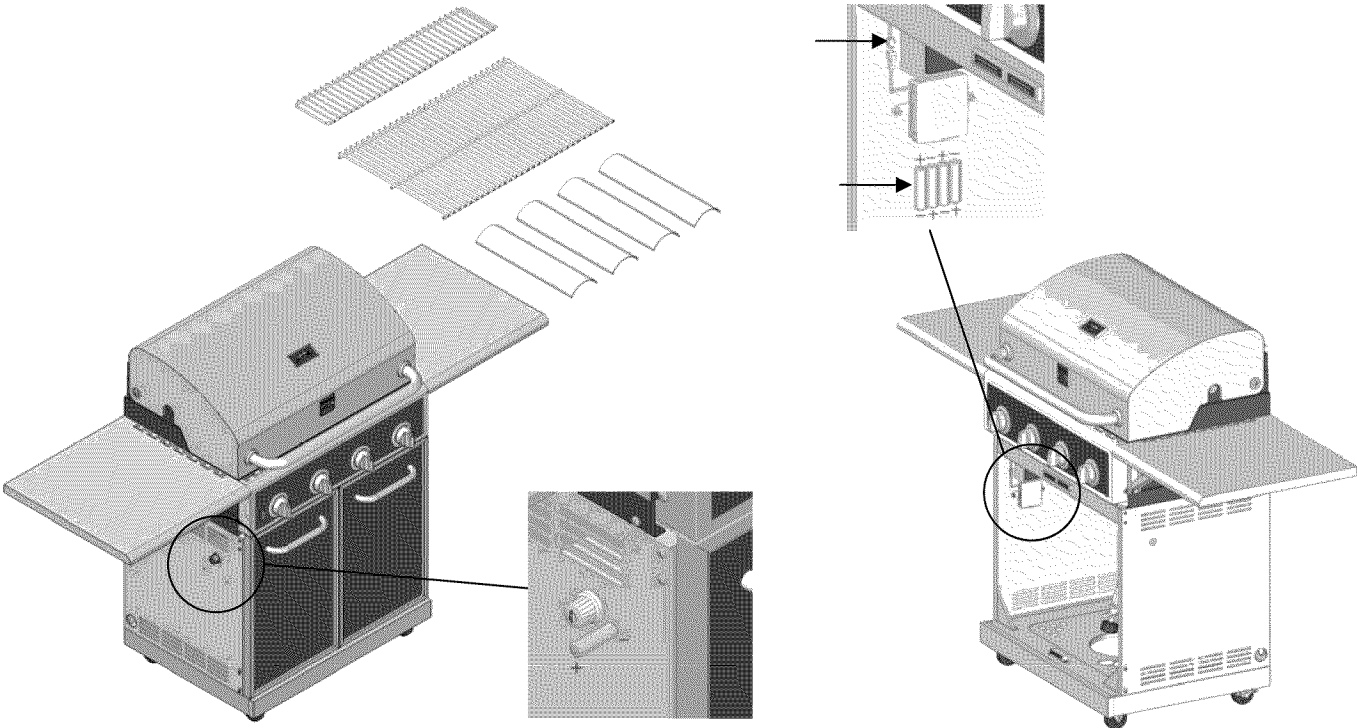

16

LP Tank Installation

Put the tank into the tank support hole with tank collar opening facing to the right as shown. Connect the regulator to the tank (see page 5 of Use and Care section).

Lock the tank with the wing-head screw as shown.

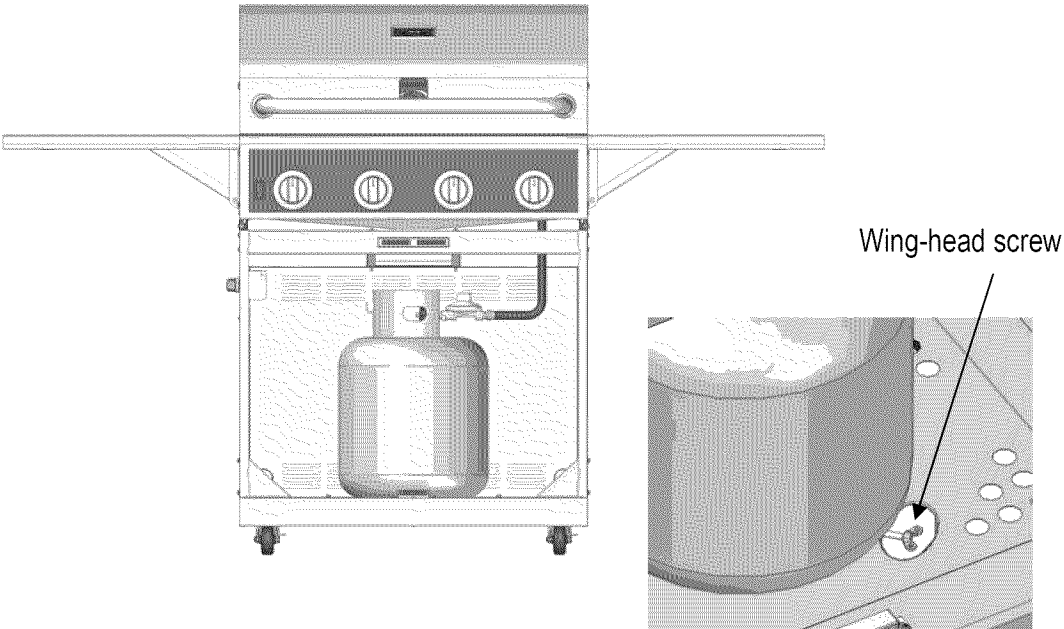

Conversion Instructions for 16154



Main Burner Conversion

1. Remove the R pins at the back of main burners to detach burners from bracket. Lift back of main burners while sliding burners out of firebox, disengaging main burners from valves. (Fig. 1)

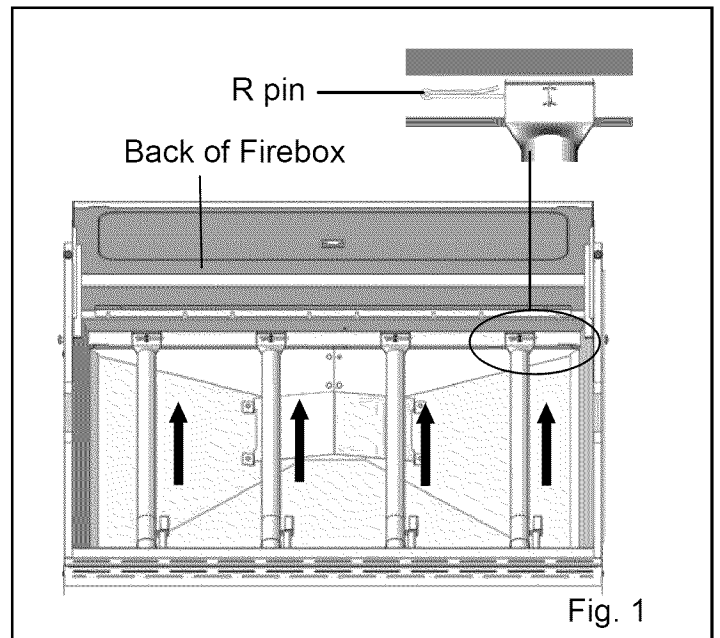

2. Insert the provided orifice removal tool (B) into burner openings and unscrew orifices from ends of valves. (Fig. 2)

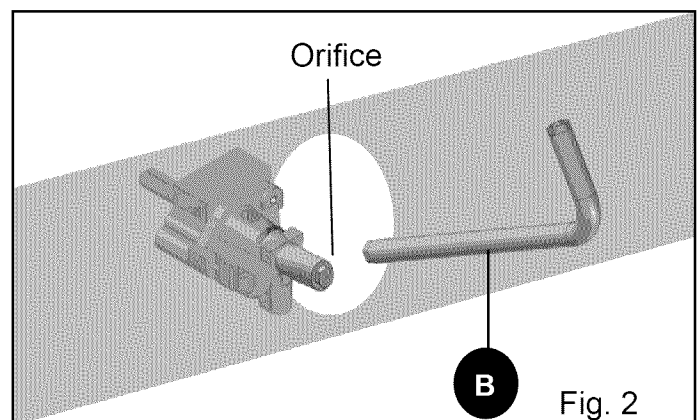

- Put the new orifice into the orifice removal tool (B), and then insert the tool into the burner opening and tighten the new orifice into the valve.
Repeat this step for all four burners.
Make sure you are using the correct orifice, which is marked “1.37”. (Fig. 3)

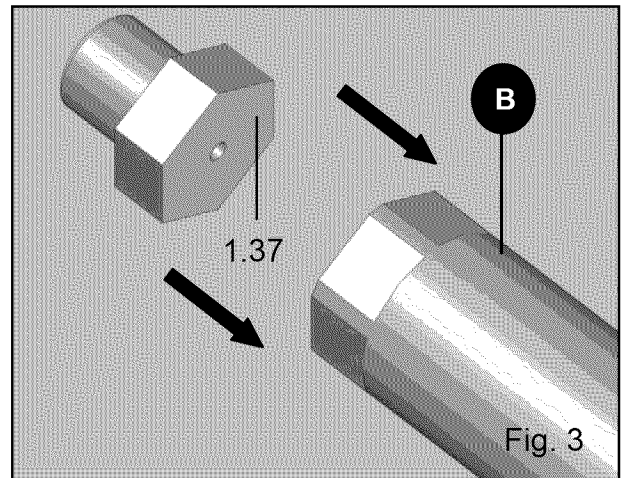

- Rotate the air shutter opening from the LP setting to the NG setting.
LP: 1/4 in. open
NG: 1/8 in. to 1/6 in. open
(Fig. 4)

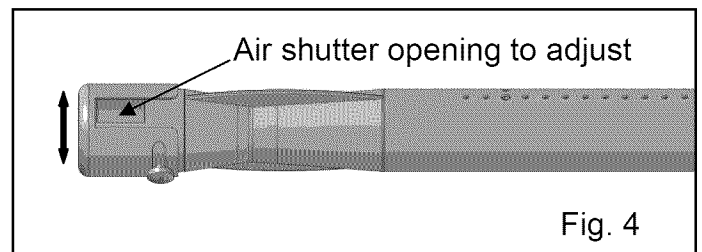

Natural Gas Hose Connection

Remove the LP gas hose and regulator using a wrench, and attach the natural gas hose in it's place. (Fig. 5)

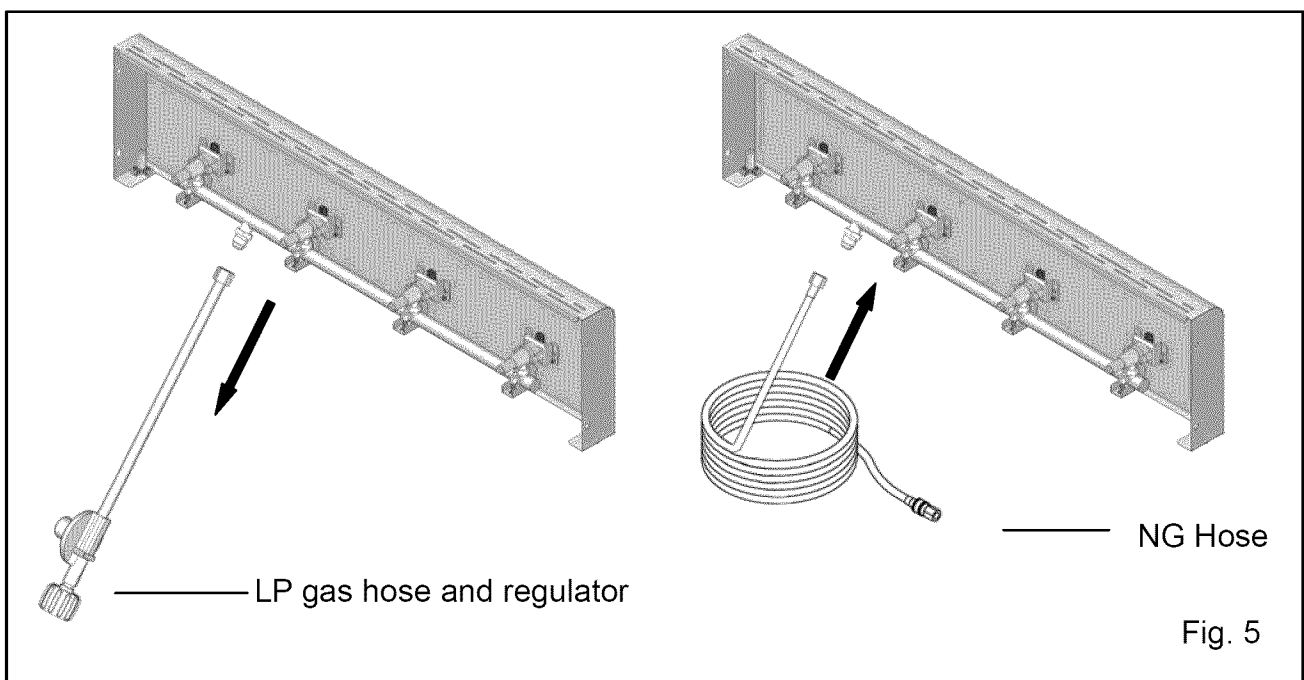

Adjust valve control screw

1. Pull all the knobs off of valve stems. Adjust the screw in the valve hole using the flathead screwdriver (C). Turn screws 6 complete turns counterclockwise.
(Fig. 6)

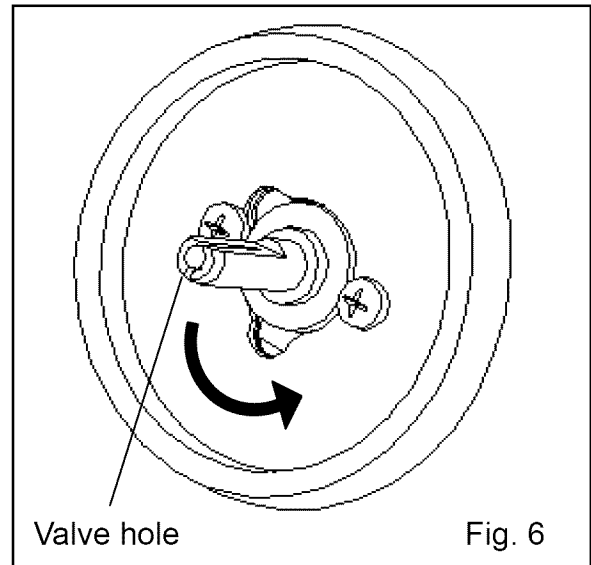

2. Press all the knobs back onto valve stems.

After all the conversions are complete, return heat diffusers to firebox, followed by the grates and warming rack.

Troubleshooting

Problem	Possible Cause	Corrective Action
Grill will not light	<ol style="list-style-type: none"> 1. The ignition wire came off the electrical igniter. 2. The distance between the ignition pin and the burner is greater than 0.1-0.2 in. 3. The ignition wire is broken. 4. The battery has died. 5. The battery is in the wrong polarity. 6. The electrode tip does not produce sparks at the burner port. 7. No gas supplied. 8. Air shutter opening is too big. 	<ol style="list-style-type: none"> 1. Reconnect the ignition wire to the electrical igniter. 2. Loosen the ignition pin and adjust the distance, then fasten it again. 3. Call customer service for correct placement of ignition wire. 4. Install a new AA battery. 5. Change the battery polarity. 6. Reinstall the electrode. 7. Turn on the regulator valve. 8. Loosen the air shutter and adjust the opening to a smaller size.
Burner flame is yellow and gas odor can be smelled	<ol style="list-style-type: none"> 1. The air shutter opening is not properly set. 2. Spiders or insects block the air shutter. 3. Gas leaks 	<ol style="list-style-type: none"> 1. Loosen the air shutter and adjust the opening to have blue flames. 1/4 in. opening for LPG. 1/6 in. or less opening for NG. 2. Clean blockages. 3. Check for the source of gas leaks.
Excessive flare-up	<ol style="list-style-type: none"> 1. Grilling fatty meats while knobs are on "HIGH". 2. Spray water on gas flames. 3. Hood closed when grilling. 	<ol style="list-style-type: none"> 1. Grill fatty meats when the grids are cold while the knobs are on the "LOW" setting. Move the meats to the warming rack if flare up continues until flame settles down. 2. Never spray water on gas flames. 3. Hood up when grilling.
Burner blows out	<ol style="list-style-type: none"> 1. LP tank is empty. 2. Burner is not aligned with the control valve. 3. Gas supply is not sufficient. 	<ol style="list-style-type: none"> 1. Refill the LP Tank. 2. Install the burner correctly. 3. Check the gas supply hose and make sure there are no leaks and no knots.

Problem	Possible Cause	Corrective Action										
Low heat with the knob in "HI" position	<ol style="list-style-type: none"> 1. Low heat is found in natural gas models. 2. Ports are blocked. 3. LP tank has run out. 	<ol style="list-style-type: none"> 1. This model is set for 7 in. natural gas usage. Please check your natural gas supply system to have correct gas pressure. Regulator is not needed for NG model. Check the orifice if you installed NG nozzles. 2. Clear ports of any obstructions. 3. Refill the LP tank. 										
Low heat, natural gas	Gas pressure is significantly affected by gas line and length of gas line from house gas line.	<p>Check your gas line and make corrections by following the chart below.</p> <table border="1" data-bbox="898 741 1430 1070"> <thead> <tr> <th colspan="2" data-bbox="898 741 1430 815">From House to Grill</th> </tr> <tr> <th data-bbox="898 815 1091 871">Distance</th> <th data-bbox="1091 815 1430 871">Tubing Size</th> </tr> </thead> <tbody> <tr> <td data-bbox="898 871 1091 927">Up to 25 ft.</td> <td data-bbox="1091 871 1430 927">3/8 in. diameter</td> </tr> <tr> <td data-bbox="898 927 1091 983">26 -50 ft.</td> <td data-bbox="1091 927 1430 983">1/2 in. diameter</td> </tr> <tr> <td data-bbox="898 983 1091 1070">51 -100 ft.</td> <td data-bbox="1091 983 1430 1070">2/3 in. of run 3/4 in. 1/3 in. of run 1/2 in.</td> </tr> </tbody> </table>	From House to Grill		Distance	Tubing Size	Up to 25 ft.	3/8 in. diameter	26 -50 ft.	1/2 in. diameter	51 -100 ft.	2/3 in. of run 3/4 in. 1/3 in. of run 1/2 in.
From House to Grill												
Distance	Tubing Size											
Up to 25 ft.	3/8 in. diameter											
26 -50 ft.	1/2 in. diameter											
51 -100 ft.	2/3 in. of run 3/4 in. 1/3 in. of run 1/2 in.											
Low heat, LP gas	The propane regulator assembly incorporates an excess flow device designed to supply the grill with sufficient gas flow. Rapid changes in pressure can trigger the excess flow device, providing a low flame and low temperature.	<p>Please follow these instructions:</p> <ol style="list-style-type: none"> 1. Make sure all burners are "OFF". 2. Open the tank valve and wait 5 minutes. 3. Light the burner one at a time following the lighting instructions listed on the door liner 										
Sudden drop in gas flow or low flame	<ol style="list-style-type: none"> 1. Out of gas. 2. Excess flow valve tripped. 3. Vapor lock at coupling nut/LP cylinder connection. 	<ol style="list-style-type: none"> 1. Check for gas in LP cylinder. 2. Turn off knobs, wait 30 seconds and light grill. If flames are still low, turn off knobs and LP cylinder valve. Disconnect regulator. Reconnect regulator and leak test. Turn on LP cylinder valve, wait 30 seconds and then light grill. 3. Turn off knobs and LP cylinder valve. Disconnect coupling nut from cylinder. Reconnect and retry. 										