

INSTRUCTION MANUAL

FREE-STANDING COOKER

EN

TRA90BL9
TRA90P9
TRA90WH9
TRA90SG-9



Dear customer, we would like to thank you for your confidence in us.

By choosing our product, you have opted for solutions where research for beauty meets innovative technical design to provide unique pieces of furniture.

We hope you get the most out of your household appliance.

Kindest regards.

Contents

1 Instructions	4
1.1 General safety instructions	4
1.2 Manufacturer liability	9
1.3 This user manual	9
1.4 Identification plate	9
1.5 Disposal	9
1.6 How to read the user manual	10
2 Description	11
2.1 General Description	11
2.2 Cooking hob	12
2.3 Control panel	12
2.4 Other parts	13
2.5 Available accessories	13
3 Use	15
3.1 Instructions	15
3.2 First use	16
3.3 Using the accessories	17
3.4 Using the storage compartment	19
3.5 Using the cooktop	20
3.6 Using the oven	21
3.7 Cooking advice	23
3.8 Programmer clock	24
4 Cleaning and maintenance	28
4.1 Instructions	28
4.2 Cleaning the appliance	28
4.3 Vapour Clean	30
4.4 Removing the door	32
4.5 Cleaning the door glazing	32
4.6 Extraordinary maintenance	33
5 Installation	36
5.1 Minimum clearance to combustible surfaces	36
5.2 Gas connection	36
5.3 Adaptation to different types of gas	39
5.4 Positioning	40
5.5 Electrical connection	43
5.6 For the installer	44

We advise you to read this manual carefully, which contains all the instructions for maintaining the appliance's aesthetic and functional qualities.

For further information on the product: www.smeg.com



Instructions

1 Instructions

1.1 General safety instructions

Risk of personal injury

- During use the appliance and its accessible parts become very hot. Never touch the heating elements during use.
- Protect your hands by wearing oven gloves when handling food inside the oven cavity.
- Never try to put out a fire or flames with water: turn off the appliance and smother the flames with a fire blanket or other appropriate cover.
- This appliance may be used by children aged at least 8 and by people of reduced physical, sensory or mental capacity, or lacking in experience in the use of electrical appliances, as long they are supervised or instructed by adults who are responsible for their safety.
- The appliance is not intended for use by persons (including children) with reduced physical, sensory or mental capabilities, or lack of experience and knowledge, unless they have been given supervised or instruction concerning use of the appliance by a responsible person for their safety.
- Children must not be allowed to play with the appliance.
- Young children should be supervised to ensure that they do not play with the appliance.
- Keep children under eight years of age at a safe distance if they are not constantly supervised.
- Do not allow children younger than 8 years old to come near the appliance when in operation.
- During use the appliance becomes hot. Care should be taken to avoid touching heating elements inside the oven.
- **WARNING:** Ensure the appliance is switched off before replacing the lamp to avoid the possibility of electric shock.
- **WARNING -** Accessible parts will become hot when in use. To avoid burns young children should be kept away.
- **Danger of fire –** Do not store items on the cooking surface.
- **CAUTION –** The cooking process has to be supervised. A short term cooking process has to be supervised continuously.
- **Warning –** Unattended cooking on a hob with fat or oil can be dangerous and may result in a fire.
- This appliance is not intended to be operated by means of external



- timer or separate remote control system.
- Cleaning and maintenance must not be carried out by unsupervised children.
 - Make sure that the flame-spreader crowns are correctly positioned in their housings with their respective burner caps.
 - Be aware of how rapidly the cooking zones heat up. Do not place empty pans on the heat. Danger of overheating.
 - Fats and oils can catch fire if they overheat. Do not leave the appliance unattended while preparing foods containing oils or fats. If fats or oils catch fire, never put water on them. Place the lid on the pan and turn off the relevant cooking zone.
 - The cooking process must always be monitored. Short cooking processes must be monitored continuously.
 - When in use, do not place metal objects, such as dishes or cutlery, on the surface of the cooktop as they may overheat.
 - Do not insert pointed metal objects (cutlery or utensils) into the slots in the appliance.
 - Do not pour water directly onto very hot trays.
 - Keep the oven door closed during cooking.
 - If you need to move food or at the end of cooking, open the door 5 cm for a few seconds, let the steam come out, then open it fully.
 - Do not open the storage compartment (if present) when the oven is on and still hot.
 - The items inside the storage compartment could be very hot after the oven has been used.
 - **DO NOT USE OR STORE FLAMMABLE MATERIALS IN THE APPLIANCE STORAGE DRAWER OR NEAR THIS APPLIANCE.**
 - **DO NOT SPRAY AEROSOLS IN THE VICINITY OF THIS APPLIANCE WHILE IT IS IN OPERATION.**
 - Switch the appliance off immediately after use.
 - **DO NOT MODIFY THIS APPLIANCE.**
 - Before carrying out any work on the appliance (installation, maintenance, positioning or moving), wear personal protective equipment.
 - Before carrying out any work on the appliance, disconnect the mains power supply.
 - Have authorised persons carry out installation and assistance



Instructions

interventions according to the standards in force.

- Do not try to repair the appliance yourself or without the intervention of authorised persons.
- Do not pull the cable to remove the plug.
- If the power supply cable is damaged, contact technical support immediately and they will replace it.

Risk of damaging the appliance

- Do not use abrasive or corrosive detergents (e.g. scouring powders, stain removers and metallic sponges) on glass parts.
- Use wooden or plastic utensils.
- Racks and trays must be inserted as far as they will go into the side guides. The mechanical safety locks that prevent them from being removed must face downwards and towards the back of the oven cavity.
- Do not seat on the appliance.
- Do not use steam jets to clean the appliance.
- Do not obstruct ventilation openings and heat dispersal slots.
- Never leave the appliance unattended during cooking operations in which fats or oils could be released that could overheat and catch fire. Be very

careful.

- Do not use a steam cleaner to clean this appliance.
- Do not use harsh abrasive cleaners or sharp metal scrapers to clean the oven glass door since they can scratch the surface, which may result in shattering of the glass.
- Never leave objects on the cooking surface.
- DO NOT USE THIS APPLIANCE AS A SPACE HEATER.
- DO NOT PLACE ARTICLES ON OR AGAINST THIS APPLIANCE.
- Do not spray any spray products near the oven.
- Do not use plastic kitchenware or containers when cooking food.
- Do not put sealed tins or containers in the oven.
- Remove all trays and racks which are not required during cooking.
- Do not cover the bottom of the oven cavity with aluminium or tin foil sheets.
- Do not place pans or trays directly on the bottom of the oven cavity.
- If you wish to use greaseproof paper, place it so that it will not interfere with the hot air circulation inside the oven.
- Do not use the open door to rest pans or trays on the internal glass



panel.

- The cooking vessels or griddle plates should be placed inside the perimeter of the cooktop.
- All cookware must have smooth, flat bottoms.
- If any liquid does boil over or spill, remove the excess from the cooktop.
- Take care not to spill acidic substances such as lemon juice or vinegar onto the cooktop.
- Do not put empty pans or frying pans on switched on cooking zones.
- Do not use steam jets to clean the appliance.
- Do not use rough or abrasive materials or sharp metal scrapers.
- Do not use cleaning products containing chlorine, ammonia or bleach on steel parts or parts with metallic surface finishes (e.g. anodizing, nickel- or chromium-plating).
- Do not use abrasive or corrosive detergents (e.g. scouring powders, stain removers and metallic sponges) on glass parts.
- Do not wash the removable components such as the cooktop pan stands, flame-spreader crowns and burner caps in a dishwasher.

- Never use the oven door to lever the appliance into place when fitting.
- Avoid exerting too much pressure on the oven door when open.
- Do not use the handle to lift or move the appliance.
- Not suitable for use with aftermarket lids or covers.

Installation

- **THIS APPLIANCE MUST NOT BE INSTALLED IN BOATS OR CARAVANS.**
- The appliance must not be installed on a stand.
- Position the appliance into the cabinet cutout with the help of a second person.
- To prevent overheating, the appliance must not be installed behind a decorative door or a panel.
- The gas connection should be carried out by authorised persons.
- Installation with flexible hose must be carried out so that the length of the piping does not exceed 2 metres when fully extended as regards flexible steel hoses and 1.5 metres in case of rubber hoses.
- The hoses should not come into contact with moving parts and should not be crushed in any way.



Instructions

- If required, use a pressure regulator that complies with current regulations.
- After carrying out any operation, check that the tightening torque of gas connections is between 10 Nm and 15 Nm.
- If the electrical supply is restricted, means of allpole disconnection must be accessible and incorporated in the fixed wiring in accordance with the wiring rules.
- If this cooking range is to be connected to a new or upgraded electrical installation, then it must be connected by a supply cord fitted with: 1) An appropriate rated plug that is compatible with the socket-outlet fitted to the final sub circuit in the fixed wiring that supplies this cooker. 2) An appropriate rated installation male connector that is compatible with the installation female connector fitted to the final sub-circuit in the fixed wiring that supplies the cooker.
- At the end of the installation, check for any leaks with a soapy solution, never with a flame.
- Have the electrical connection performed by authorised persons.
- The appliance must be connected to earth in compliance with electrical system safety standards.

- Use cables withstanding a temperature of at least 90°C.
- The tightening torque of the screws of the terminal supply wires must be 1.5 - 2 Nm.
- If this appliance is installed on a base, measures must be taken to prevent the appliance from slipping from the base.



For this appliance

- Ensure that the appliance is switched off before replacing the bulb.
- Do not rest any weight or sit on the open door of the appliance.
- Take care that no objects are stuck in the doors.
- Place the supplied data plate to a suitable adjacent surface or within the instruction manual for future reference.

Appliance purpose

- This appliance is intended for cooking food in the home environment. Every other use is considered improper.
- The appliance is not designed to operate with external timers or with



remote-control systems.

1.2 Manufacturer liability

The manufacturer declines all liability for damage to persons or property caused by:

- use of the appliance other than the one envisaged;
- non-observance of the user manual provisions;
- tampering with any part of the appliance;
- use of non-original spare parts.

1.3 This user manual

This user manual is an integral part of the appliance and must therefore be kept in its entirety and in an accessible place for the whole working life of the appliance.

Read this user manual carefully before using the appliance.

1.4 Identification plate

- The identification plate bears the technical data, serial number and brand name of the appliance. Do not remove the identification plate for any reason.

1.5 Disposal

To dispose of the appliance:

- Cut the power supply cable and remove it along with the plug.



Power voltage

Danger of electrocution

- Disconnect the main power supply.
- Disconnect the power cable from the electrical system.
- Consign the appliance to the appropriate selective collection centres for electrical and electronic equipment waste, or deliver it back to the retailer when purchasing an equivalent product, on a one for one basis.

Our appliances are packed in non-polluting and recyclable materials.

- Consign the packing materials to the appropriate selective collection centres.



Plastic packaging

Danger of suffocation

- Do not leave the packaging or any part of it unattended.
- Do not let children play with the packaging plastic bags.



1.6 How to read the user manual

This user manual uses the following reading conventions:

Instructions



General information on this user manual, on safety and final disposal.

Description



Description of the appliance and its accessories.

Use



Information on the use of the appliance and its accessories, cooking advice.

Cleaning and maintenance



Information for proper cleaning and maintenance of the appliance.

Installation



Information for authorised persons: installation, operation and inspection.



Safety instructions



Information



Advice

1. Sequence of instructions for use.

- Standalone instruction.



2 Description

2.1 General Description

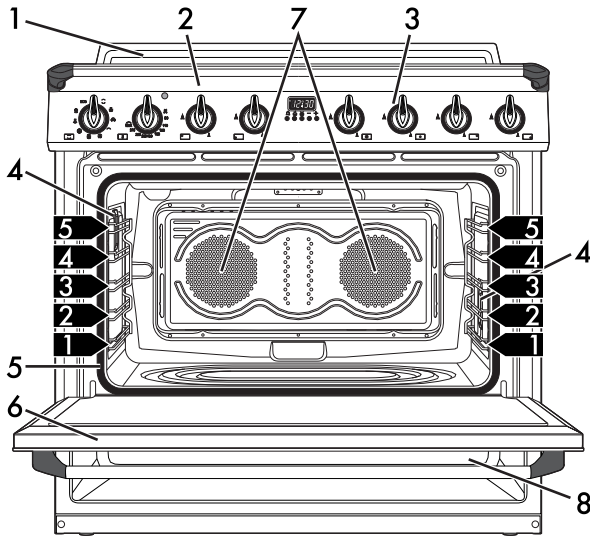

- 1 Backguard
- 2 Cooking hob
- 3 Control panel
- 4 Oven light
- 5 Seal

- 6 Door
- 7 Fan
- 8 Storage compartment

1,2,3 ▶ Rack/tray support frame shelf



Description

2.2 Cooking hob

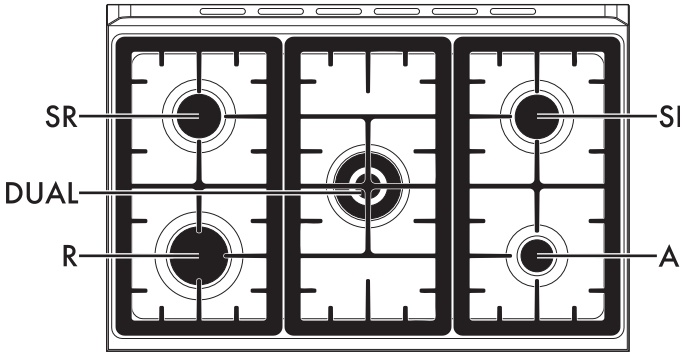

AUX = Auxiliary
SR = Semi-rapid

R = Rapid
DUAL = Ultra rapid

2.3 Control panel

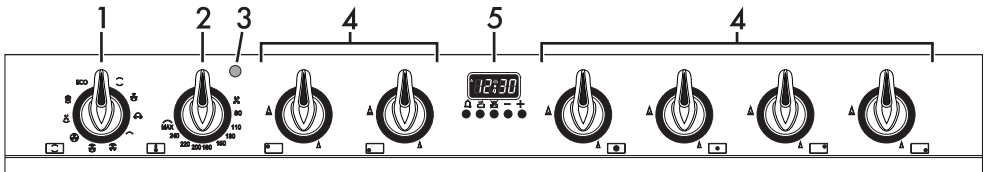

1 Function knob

The oven's various functions are suitable for different cooking modes. After selecting the required function, set the cooking temperature using the temperature knob.

2 Temperature knob

This knob allows you to select the cooking temperature.

Turn the knob clockwise to the required value, between the minimum and maximum setting.



3 Indicator light

The indicator light comes on to indicate that the oven is heating up. It turns off as soon as it reaches the set temperature. It flashes regularly to indicate that the temperature set inside the oven is kept constant.



4 Hob burner knobs

Useful for lighting and adjusting the hob burners.

Press and turn the knobs anti-clockwise to the value  to light the relative burners. Turn the knobs to the zone between the maximum  and minimum  setting to adjust the flame.

Return the knobs to the  position to turn off the burners.

5 Programmer clock

Useful for displaying the current time, setting programmed cooking operations and programming the minute minder timer.

2.4 Other parts

Shelves

The appliance features shelves for positioning trays and racks at different heights. The insertion heights are indicated from the bottom upwards (see 2.1 General Description).

Interior lighting

The appliance interior lighting comes on:

- When the door is opened
- When any function is selected.

 When the door is open, it is not possible to turn off the interior lighting.

Cooling fan

The fan cools the ovens and comes into operation during cooking.

The fan causes a steady outflow of air from above the door which may continue for a brief period of time even after the appliance has been turned off.

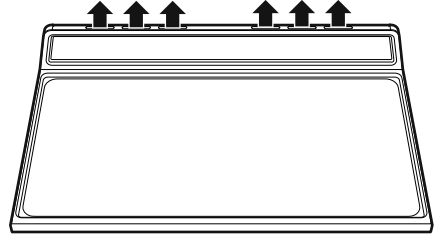

Do not obstruct ventilation openings and heat dispersal slots.

2.5 Available accessories



Some models are not provided with all accessories.

Rack

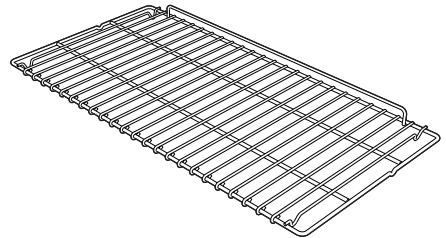

Useful for supporting containers with food during cooking.



Description

Tray rack

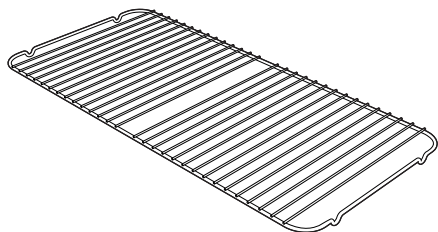

To be placed over the top of the oven tray; for cooking foods which may drip.

Deep tray

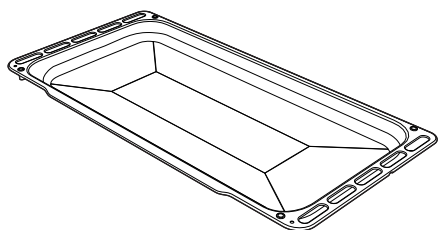

Useful for collecting fat from foods placed on the rack above.

Rotisserie rod

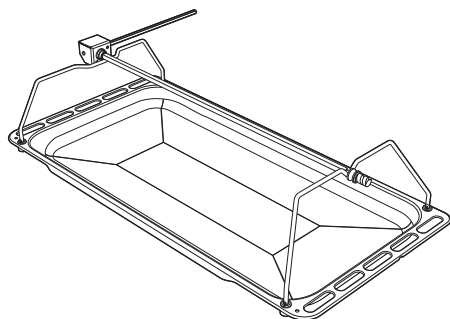

Useful for cooking chicken and all foods which require uniform cooking over their entire surface.

Reduction pan stand

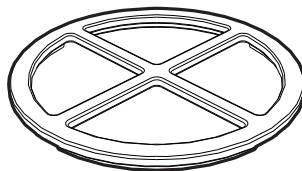

Useful when using small cookware.

WOK reduction pan stand

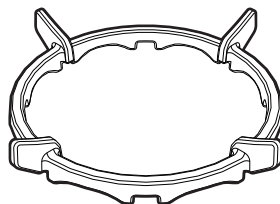

Useful when using a wok.

i The accessories intended to come into contact with food are made of materials that comply with the provisions of current legislation.

i Supplied and optional accessories can be requested to Authorised Assistance Centres. Use only original accessories supplied by the manufacturer.



3 Use

3.1 Instructions



High temperature inside the oven during use Danger of burns

- Keep the oven door closed during cooking.
- Protect your hands wearing heat resistant gloves when moving food inside the oven.
- Do not touch the heating elements inside the oven.
- Do not pour water directly onto very hot trays.
- Do not allow children younger than 8 years old to come near the appliance when in operation.
- If you need to move food or at the end of cooking, open the door 5 cm for a few seconds, let the steam come out, then open it fully.



Improper use Danger of burns

- Make sure that the flame-spreader crowns are correctly positioned in their housings with their respective burner caps.
- Oils and fat could catch fire if overheated. Be very careful.



Improper use Risk of damage to surfaces

- Do not cover the bottom of the oven cavity with aluminium or tin foil sheets.
- If you wish to use greaseproof paper, place it so that it will not interfere with the hot air circulation inside the oven.
- Do not place pans or trays directly on the bottom of the oven cavity.
- Do not use the open door to rest pans or trays on the internal glass pane.
- Do not pour water directly onto very hot trays.
- Make sure that the flame-spreader crowns are correctly positioned in their housings with their respective burner caps.
- The cooking vessels or griddle plates should be placed inside the perimeter of the cooktop.
- All pans must have smooth, flat bottoms.
- If any liquid does boil over or spill, remove the excess from the cooktop.



High temperature inside the storage compartment Danger of burns

- Do not open the storage compartment when the oven is on and still hot.
- The items inside the storage compartment could be very hot after using the oven.



High temperature inside the oven during use

Danger of fire or explosion

- Do not spray any spray products near the oven.
- Do not use or leave flammable materials near the oven or the storage compartment.
- Do not use plastic kitchenware or containers when cooking food.
- Do not put sealed tins or containers in the oven.
- Do not leave the oven unattended during cooking operations where fats or oils could be released.
- Remove all trays and racks which are not required during cooking.
- Do not use this appliance as a space heater.
- Do not modify this appliance.

Escaping gas may cause an explosion.

If you smell gas or notice any faults in the gas installation:

- Immediately shut off the gas supply or close the gas cylinder valve.
- Immediately extinguish all naked flames and cigarettes.
- Do not use any light or appliance switches and do not pull any plugs out of sockets. Do not use any telephones or mobile phones within the building.
- Open windows and ventilate the room.
- Call the aftersales service or the gas supplier.

Abnormal operation

Any of the following are considered to be abnormal operation and may require service:

- Yellow tipping of the hotplate burner flame.
- Sooting up of cooking utensils.
- Burners not igniting properly.
- Burners failing to remain alight.
- Burners extinguishing whilst in operation.
- Gas valves which are difficult to turn.

In case the appliance fails to operate correctly, contact the Authorised Assistance Centre in your area.

3.2 First use

1. Remove any protective film from the outside or inside of the appliance, including accessories.
2. Remove any labels (apart from the technical data plate) from the accessories and from the cooking compartments.
3. Remove all the accessories from the appliance and clean them (see 4 Cleaning and maintenance). Heat the empty ovens at the maximum temperature to burn off any residues left by the manufacturing process.



3.3 Using the accessories

Reduction pan stands

The reduction pan stands have to be placed on the hob grids. Make sure they are properly placed.

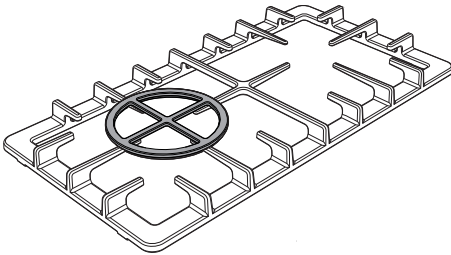
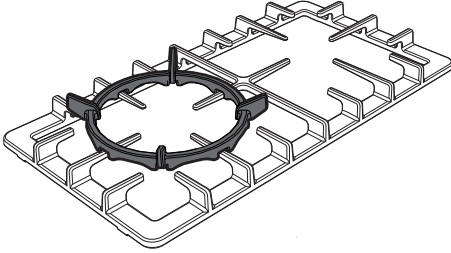

Tray rack

The tray rack has to be inserted into the tray. In this way fat can be collected separately from the food which is being cooked.

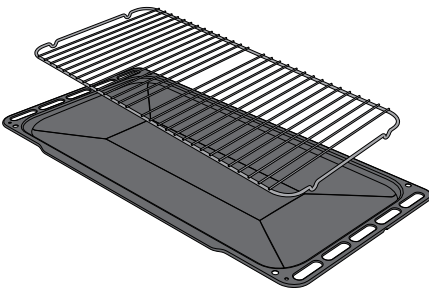

Racks and trays

Racks and trays have to be inserted into the side guides until they come to a complete stop.

- The mechanical safety locks that prevent the rack from being taken out accidentally have to face downwards and towards the oven back.

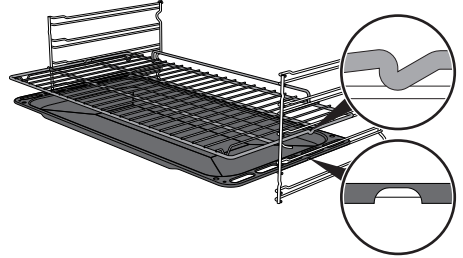

Gently insert racks and trays into the oven until they come to a stop.



Clean the trays before using them for the first time to remove any residues left by the manufacturing process.



Use

Rotisserie rod

1. Insert the 4 supplied bushings in the 4 corner holes of the deep tray and screw them onto the ring nuts with a suitable tool (such as a screwdriver).

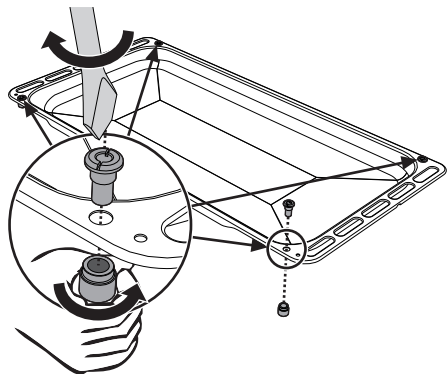

2. Position the rotisserie supports in the bushings as shown in the figure below.

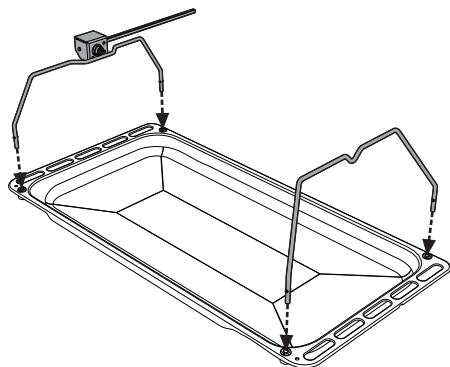

3. Prepare the rotisserie rod with the food using the clip forks provided. The clip forks can be tightened using the fastening screws.

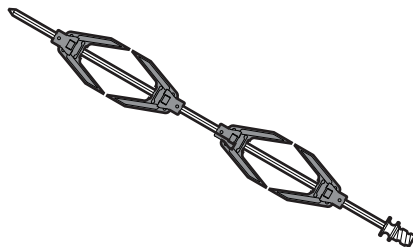

4. Once you have prepared the rotisserie rod, place it on the supports. Insert the tip of the rod in the housing of the mechanism on the left-hand support until it stops.

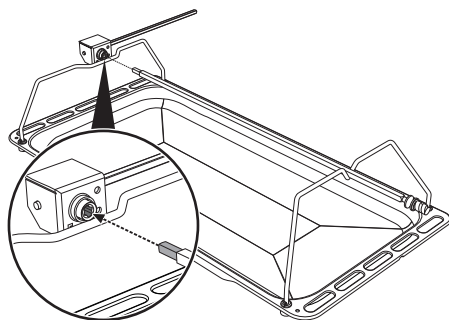

5. Place the tray on the first runner (see "General Description").



6. Insert the tip of the rod in the rotisserie motor housing on the left of the rear wall of the oven.

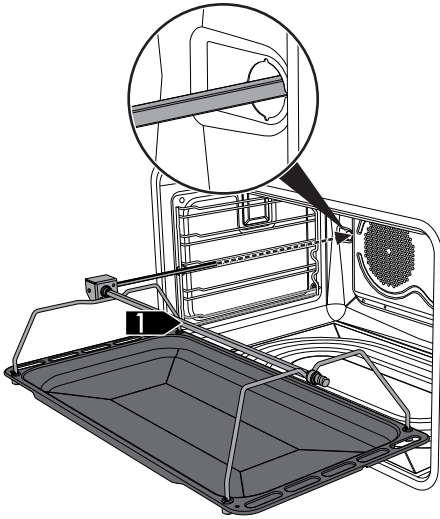

These operations must be performed with the oven off and cold.

7. To activate the rotisserie, turn the function knob to the  position and set the cooking temperature using the temperature knob.



Pour a little water into the tray to prevent smoke from forming.

8. When cooking is complete, remove the tray with the rotisserie.
9. Screw on the handle provided so that you can handle the rotisserie rod more easily.

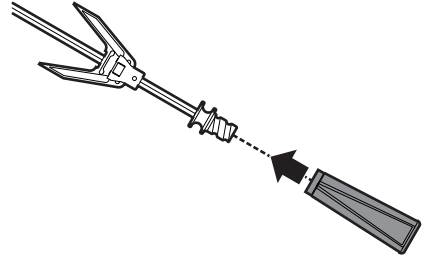

3.4 Using the storage compartment

The storage compartment is at the bottom of the cooker. It can be used to store cookware or metallic objects necessary when using the appliance.

- To open it, pull the handle towards you.

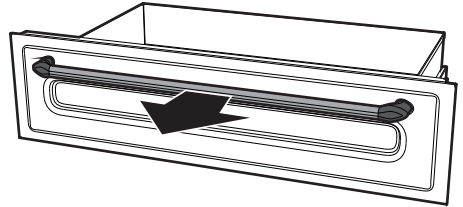



3.5 Using the cooktop

All the appliance's control and monitoring devices are located together on the front panel. The burner controlled by each knob is shown next to the knob. The appliance is equipped with an electronic ignition device. Simply press the knob and turn it anti-clockwise to the maximum flame symbol, until the burner lights. If the burner does not light in the first 15 seconds, turn the knob to

 and wait 60 seconds before trying again. After lighting, keep the knob pressed in for a few seconds to allow the thermocouple to heat up. The burner may go out when the knob is released: in this case, the thermocouple has not heated up sufficiently. Wait a few moments and repeat the operation. Keep the knob pressed in longer.



In case of an accidental switching off, a safety device will be tripped, cutting off the gas supply, even if the gas cock is open. Return the knob to  and wait at least 60 seconds before lighting it again.

Correct positioning of the flame-spreader crowns and burner caps

Before lighting the hob burners, make sure that the flame-spreader crowns are correctly positioned in their seats with their respective burner caps. Make sure that the holes **1** of the flame-spreader crowns are aligned with the thermocouples **2** and igniters **3**.

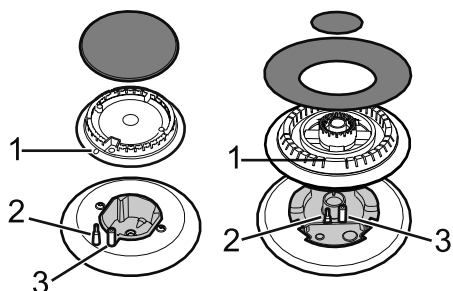

Practical tips for using the hob

For better burner efficiency and to minimise gas consumption, use pans with lids and of suitable size for the burner, so that the flames do not reach up the sides of the pan. Once the contents come to the boil, turn down the flame far enough to ensure that the liquid does not boil over.



Cookware diameters:

- AUX: 12 - 14 cm.
- SR: 16 - 24 cm.
- R: 18 - 26 cm.
- DUAL: 18 - 28 cm.



3.6 Using the oven

Switching on the oven

To switch on the oven:

1. Select the cooking function using the function knob.
2. Select the temperature using the temperature knob.



Ensure that the programmer clock shows the cooking duration symbol , otherwise it will not be possible to turn on the oven.

Press the key  to reset the programmer clock.

Functions list



Convection

As the heat comes from above and below at the same time, this system is particularly suitable for certain types of food. Traditional cooking, also known as convection cooking, is suitable for cooking just one dish at a time. Perfect for all types of roasts, bread and cakes, and in any case, particularly suitable for fatty meats such as goose and duck.



Baker's function

The combination of the fan with just the lower heating element allows cooking to be completed more rapidly. This system is recommended for sterilising or for finishing off the cooking of foods which are already well-cooked on the surface, but not inside, which therefore need a little more heat. Perfect for any type of food.



Rotisserie

The rotisserie works in combination with the central grill heating element and allows food to be perfectly browned.



Grill

The heat coming from the grill element gives perfect grilling results above all for thin and medium thickness meat and, in combination with the rotisserie (where fitted), gives the food an even browning at the end of cooking. Perfect for sausages, spare ribs and bacon. This function enables large quantities of food, particularly meat, to be grilled evenly.



Fan grill

The air produced by the fan softens the strong heatwave generated by the grill, grilling perfectly even very thick foods. Perfect for large cuts of meat (e.g. pork hock).



Use



Fan assisted

The operation of the fan, combined with traditional cooking, ensures consistent cooking even with complex recipes. Perfect for biscuits and cakes, even when simultaneously cooked on several levels. (For multiple-level cooking, we recommend using the 2nd and 4th shelf).



Fan forced

The combination of the fan and the circular heating element (incorporated in the rear of the oven) allows you to cook different foods on several levels, as long as they need the same temperatures and same type of cooking. Hot air circulation ensures instant and even distribution of heat. It will be possible, for instance, to cook fish, vegetables and biscuits simultaneously (on different levels) without odours and flavours mingling.



Bottom

The heat coming just from the bottom allows you to complete the cooking of foods that require a higher bottom temperature, without affecting their browning. Perfect for cakes, pies, tarts and pizzas.



Rapid defrost

Rapid defrost is helped by switching on the fan provided and the top heating element that ensure uniform distribution of low temperature air inside the oven.

ECO

Eco

This function is particularly suitable for cooking on a single shelf with low energy consumption.

Ideal for cooking meat, fish and vegetables. It is not recommended for leavened foods.

To obtain maximum energy savings and reduce cooking times, it is recommended to place food in the oven without preheating.



When using the ECO function, avoid opening the door during cooking.



Cooking (and preheating) times are longer with the ECO function.



3.7 Cooking advice

General advice

- Use a fan assisted function to achieve consistent cooking at several levels.
- It is not possible to shorten cooking times by increasing the temperature (the food could be overcooked on the outside and undercooked on the inside).

Advice for cooking meat

- Cooking times vary according to the thickness and quality of the food and to consumer taste.
- Use a meat thermometer when roasting meat, or simply press on the roast with a spoon. If it is hard, it is ready; if not, it needs another few minutes cooking.

Advice for cooking with the Grill and the Fan grill

- Meat can be grilled even when it is put into the cold oven or into the preheated oven if you wish to change the effect of the cooking.
- With the Fan grill function, we recommend that you preheat the oven before grilling.
- We recommend placing the food at the centre of the rack.
- With the Grill function, we recommend that you turn the temperature knob to the maximum value near the  symbol to optimise cooking.
- Foods should be seasoned before cooking. Foods should also be coated with oil or melted butter before cooking.
- Use the oven tray on the first bottom shelf to collect fluids produced by grilling.
- Grilling processes should never last more than 60 minutes.

Advice for cooking desserts/pastries and biscuits

- Use dark metal moulds: they help to absorb the heat better.
- The temperature and the cooking time depend on the quality and consistency of the dough.
- To check whether the dessert is cooked right through: at the end of the cooking time, put a toothpick into the highest point of the dessert. If the dough does not stick to the toothpick, the dessert is cooked.
- If the dessert collapses when it comes out of the oven, on the next occasion reduce the set temperature by about 10°C, selecting a longer cooking time if necessary.
- While cooking desserts or vegetables, excessive condensation may form on the glass. In order to avoid this, open the door very carefully a couple of times while cooking.

Advice for defrosting and proving

- Place frozen foods without their packaging in a lidless container on the first shelf of the oven.
- Avoid overlapping the food.
- To defrost meat, use the rack placed on the second level and a tray on the first level. In this way, the liquid from the defrosting food drains away from the food.
- The most delicate parts can be covered with aluminium foil.
- For successful proving, a container of water should be placed in the bottom of the oven.



To save energy

- Stop cooking a few minutes before the time normally used. Cooking will continue for the remaining minutes with the heat which has accumulated inside the oven.
- Reduce any opening of the door to a minimum to avoid heat dispersal.
- Keep the inside of the appliance clean at all times.

3.8 Programmer clock

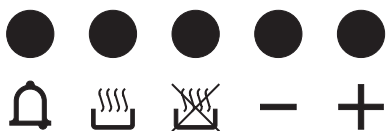

 Minute minder timer key



 Cooking duration key

 End of cooking key

 Value decrease key

 Value increase key







i Ensure that the programmer clock shows the cooking duration symbol , otherwise it will not be possible to turn on the oven.

Press the keys  and  at the same time to reset the programmer clock.

Setting the time

i If the time is not set, the oven will not switch on.

On the first use, or after a power failure, the digits  will be flashing on the appliance's display.

1. Press the keys  and  at the same time. The dot between the hours and the minutes flashes.
2. The time can be set using the key  or . Keep the key pressed in to increase or decrease rapidly.
3. Press the key  or wait 5 seconds. The dot between the hours and the minutes stops flashing.
4. The symbol  on the display indicates that the appliance is ready to start cooking.



Timed cooking

i Timed cooking is the function which allows a cooking operation to be started and then ended after a specific length of time set by the user.

1. After selecting a cooking function and temperature, press the key . The display will show the digits and the symbol displayed between the hours and the minutes.
2. Use the key or to set the required minutes.
3. Wait approx. 5 seconds without pressing any key in order for the function to activate. The current time and the symbols and will appear on the display.
4. At the end of cooking the heating elements will be deactivated. On the display, the symbol turns off, the symbol flashes and the buzzer sounds.
5. To turn off the buzzer just press any key of the programmer clock.
6. Press the keys and at the same time to reset the programmer clock.

It is not possible to set a cooking time of more than 10 hours.



After the setting, to display the cooking time left press the key .



To reset the set program, press the keys and at the same time and switch off the oven manually.

Programmed cooking









Programmed cooking is the function which allows a cooking operation to be started at a set time and then ended after a specific length of time set by the user.

1. Set the cooking time as described in the previous point "Timed cooking".
2. Press the key . The sum of the current time plus the pre-set cooking duration will appear on the display.
3. Use the key or to set the required minutes.
4. Wait approx. 5 seconds without pressing any key in order for the function to activate. The current time and the symbols and will appear on the display.



Use

- At the end of cooking the heating elements will be deactivated. On the display, the symbol  turns off, the symbol  flashes and the buzzer sounds.
- To turn off the buzzer just press any key of the programmer clock.
- Press the keys  and  at the same time to reset the programmer clock.

- Wait approx. 5 seconds without pressing any key to finish setting the minute minder. The current time and the symbols  and  appear on the display.





It is not possible to set a cooking time of more than 24 hours.



After the minute minder timer has been programmed, the display will go back to showing the current time. Press the key  to display the remaining time.







After the setting, to display the cooking time left press the key . To display the end of cooking time, press the key .

Minute minder timer



The minute minder timer does not stop the cooking operation but rather informs the user when the set time has run out.



The minute minder timer can be activated at any time.

- Press the key . The display shows the digits  and the indicator light  flashing between the hours and the minutes.
- Use the key  or  to set the required minutes.

Adjusting the buzzer volume

The buzzer volume can be set to 3 different levels. When the buzzer is in operation, press the key  to change the setting.

Deleting the set data

Press the keys  and  at the same time to reset the programs set. Then switch off the oven manually if cooking is in progress.



Cooking information table

Food	Weight (Kg)	Function	Shelf	Temperature (°C)	Time (minutes)	
Lasagne	3 - 4	Convection	1	220 - 230	45 - 50	
Pasta bake	3 - 4	Convection	1	220 - 230	45 - 50	
Roast veal	2	Fan assisted/Fan forced	2	180 - 190	90 - 100	
Pork	2	Fan assisted/Fan forced	2	180 - 190	70 - 80	
Sausages	1.5	Fan grill	4	MAX	15	
Roast beef	1	Fan assisted/Fan forced	2	200	40 - 45	
Roast rabbit	1.5	Fan forced	2	180 - 190	70 - 80	
Turkey breast	3	Fan assisted/Fan forced	2	180 - 190	110 - 120	
Roast pork neck	2 - 3	Fan assisted/Fan forced	2	180 - 190	170 - 180	
Roast chicken	1.2	Fan assisted/Fan forced	2	180 - 190	65 - 70	
					1 st surface	2 nd surface
Pork chops	1.5	Fan grill	4	MAX	15	5
Spare ribs	1.5	Fan grill	4	MAX	10	10
Bacon	0.7	Grill	5	MAX	7	8
Pork fillet	1.5	Fan grill	4	MAX	10	5
Beef fillet	1	Grill	5	MAX	10	7
Salmon trout	1.2	Fan assisted/Fan forced	2	150 - 160	35 - 40	
Delicate fish	1.5	Fan assisted/Fan forced	2	160	60 - 65	
Flounder	1.5	Fan assisted/Fan forced	2	160	45 - 50	
Pizza	1	Fan assisted/Fan forced	2	MAX	8 - 9	
Bread	1	Fan forced	2	190 - 200	25 - 30	
Focaccia	1	Fan assisted/Fan forced	2	180 - 190	20 - 25	
Ring cake	1	Fan forced	2	160	55 - 60	
Jam tart	1	Fan forced	2	160	35 - 40	
Ricotta cake	1	Fan forced	2	160 - 170	55 - 60	
Jam tarts	1	Fan assisted/Fan forced	2	160	20 - 25	
Paradise cake	1.2	Fan forced	2	160	55 - 60	
Profiteroles	1.2	Fan assisted/Fan forced	2	180	80 - 90	
Sponge cake	1	Fan forced	2	150 - 160	55 - 60	
Rice pudding	1	Fan assisted/Fan forced	2	160	55 - 60	
Brioche	0.6	Fan forced	2	160	30 - 35	

The times indicated in the table do not include preheating times and are provided as a guide only.



Cleaning and maintenance

4 Cleaning and maintenance

4.1 Instructions



Improper use

Risk of damage to surfaces

- Do not use steam jets to clean the appliance.
- Do not use cleaning products containing chlorine, ammonia or bleach on parts made of steel or that have metallic surface finishes (e.g. anodizing, nickel- or chromium-plating).
- Do not use abrasive or corrosive detergents (e.g. scouring powders, stain removers and metallic sponges) on glass parts.
- Do not use rough or abrasive materials or sharp metal scrapers.
- Do not wash the removable components such as the hob grids, flame-spreader crowns and burner caps in a dishwasher.

Cleaning the hob

1. Pour some non-abrasive detergent on a damp cloth and wipe the surfaces.
2. Rinse thoroughly.
3. Dry with a soft cloth or a microfibre cloth.

Cleaning the hob grids, flame-spreader crowns and burner caps

1. Remove the components from the hob.
2. Clean with lukewarm water and non-abrasive detergent. Make sure to remove any encrustations.
3. Dry thoroughly with a soft cloth or a microfibre cloth.
4. Replace the components on the hob.



The continuous contact between the grids and the flame can cause modifications to the enamel over time in those parts exposed to heat. This is a completely natural phenomenon which has no effect on the operation of this component.

4.2 Cleaning the appliance



We recommend the use of cleaning products distributed by the manufacturer.

Recommendations for cleaning the hob

To keep the surfaces in good condition, they should be cleaned regularly after use. Let them cool first.



Cleaning the igniters and thermocouples

- If necessary, clean the igniters and thermocouples with a damp cloth.
- If there is any dry residue, remove it with a toothpick or needle.

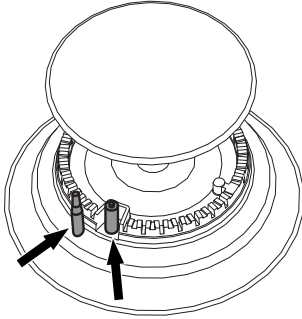

Cleaning the oven cavity

In order to keep your oven in the best possible condition, clean it regularly after letting it cool down.

Avoid letting food residue dry inside the oven cavity, as this could damage the enamel.

Take out all removable parts before cleaning.

For easier cleaning, we recommend removing:

- The door
- The rack/tray support frames
- Removable guides, where fitted
- The seal



In the event you are using specific cleaning products, we recommend running the oven at maximum temperature for 15-20 minutes in order to eliminate any residue.

Removing racks/trays support frames

Removing the rack/tray support frames enables the sides to be cleaned more easily.

To remove the rack/tray support frames:

- Pull the frame towards the inside of the oven to unhook it from its groove **A**, then slide it out of the seats **B** at the back.

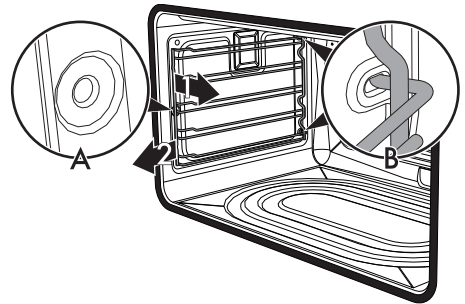

- When cleaning is complete, repeat the above procedures to put the rack/tray support frames back in.



Cleaning and maintenance

Cleaning the top section

The oven cavity is fitted with a tilting heating element which facilitates cleaning the top part (roof) of the oven.

1. Free the upper heating element by gently lifting it and rotating its retainers by 90 degrees.

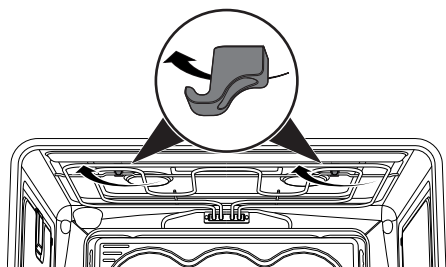

2. Gently lower the heating element until it stops.

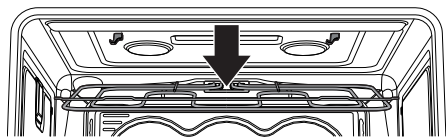

Improper use
Risk of damage to the appliance

- Do not excessively flex the element during cleaning.

3. When you have finished cleaning, place the heating element back in position and turn the retainers to lock it in place again.

4.3 Vapour Clean



Vapour Clean is an assisted cleaning procedure which facilitates the removal of dirt. Thanks to this process, it is possible to clean the inside of the oven very easily. The dirt residues are softened by the heat and water vapour for easier removal at a later stage.



Improper use
Risk of damage to surfaces

- Remove any food residues or large spills from previous cooking operations from the inside of the oven.
- Carry out assisted oven cleaning operations only when the oven is cold.

Preliminary operations

Before starting the Vapour Clean function:

- Completely remove all accessories from inside the oven.



- Pour approximately 40 cc of water into the tray. Make sure it does not overflow out of the cavity.

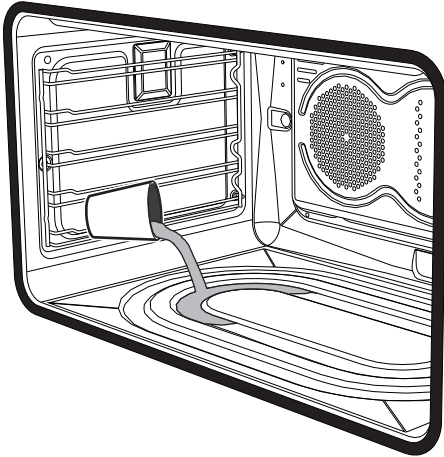

- Spray a water and washing up liquid solution inside the oven using a spray nozzle. Direct the spray against the side walls, upwards, downwards and towards the deflector.

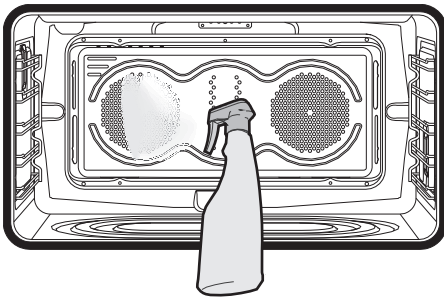



- Close the door.



We recommend spraying approx. 20 times at the most.

Vapour Clean setting

1. Turn the function knob to the symbol  and the temperature knob to the symbol .
2. Set a cooking time of 18 minutes using the programmer clock.

The Vapour Clean cycle starts a few seconds after the last press on the programmer clock keys.

3. At the end of the Vapour Clean cycle, the timer will deactivate the oven heating elements, the buzzer will start to sound and the numbers on the programmer clock dial will flash.

End of the Vapour Clean cycle

4. Open the door and wipe away the less stubborn dirt with a microfibre cloth.
5. Use an anti-scratch sponge with brass filaments on tougher encrustations.
6. In case of grease residues use specific oven cleaning products.
7. Remove the water left inside the oven.

For improved hygiene and to avoid food being affected by any unpleasant odours, we recommend that the oven is dried using a fan assisted function at 160°C for approximately 10 minutes.



We recommend wearing rubber gloves for these operations.



For easier manual cleaning of the parts difficult to reach, we recommend removing the door.



Cleaning and maintenance

4.4 Removing the door

For easier cleaning it is recommended to remove the door and place it on a tea towel.

To remove the door proceed as follows:

1. Open the door completely and insert two pins into the holes on the hinges indicated in the figure.

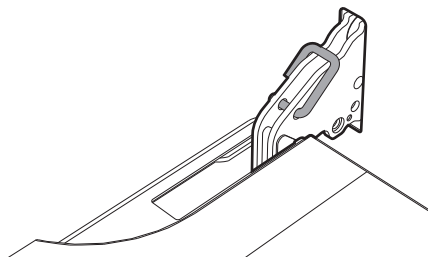

2. Grasp the door on both sides with both hands, lift it forming an angle of around 30° and remove it.

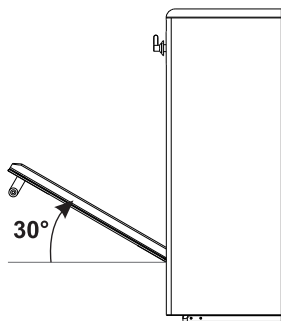

3. To reassemble the door, put the hinges in the relevant slots in the oven, making sure that grooved sections **A** are resting completely in the slots. Lower the door and once it is in place remove the pins from the holes in the hinges.

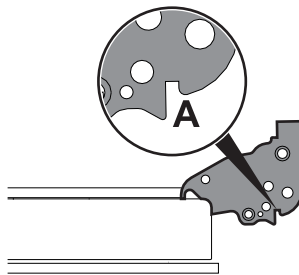

4.5 Cleaning the door glazing

The glass in the door should always be kept thoroughly clean. Use absorbent kitchen roll. In case of stubborn dirt, wash with a damp sponge and an ordinary detergent.

Removing the internal glass panes

For easier cleaning the internal glass panes of the door can be removed.

1. Open the door.
2. Place the pins into the holes to prevent accidental closing of the door.



3. Pull the rear part of the internal glass pane gently upwards, following the movement indicated by the arrows (1).

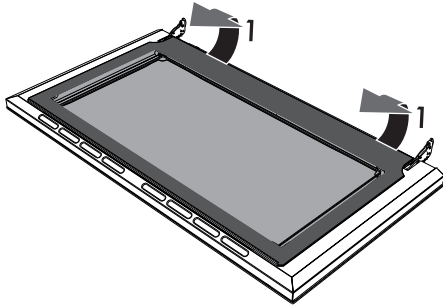

4. Extract the internal glass pane from the front strip (2) to remove it from the door.

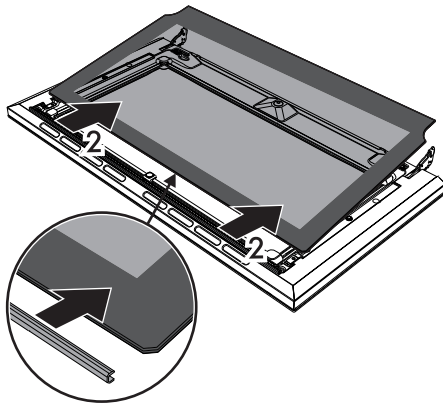

5. Remove the intermediate glass pane by lifting it upwards.

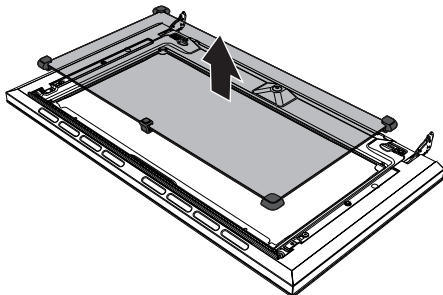

6. Clean the external glass pane and the panes removed previously. Use absorbent kitchen roll. In case of stubborn dirt, wash with a damp sponge and neutral detergent.

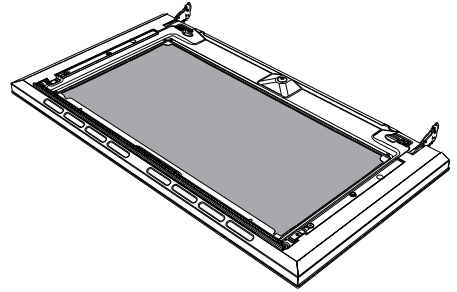

7. When you have finished cleaning, reinsert the intermediate glass pane in its housing in the door.
8. To reposition the internal glass pane, slide the upper part into the door strip and insert the two rear pins into their seats by pressing lightly.

4.6 Extraordinary maintenance

Replacing the oven light bulb



Live parts
Danger of electrocution

- Unplug the appliance.



The oven is fitted with a 40W light bulb.

1. Completely remove all accessories from inside the oven.
2. Remove the racks/trays support frames.



Cleaning and maintenance

3. Remove the bulb cover using a tool (e.g. a screwdriver).



Pay attention not to scratch the oven cavity enamel.

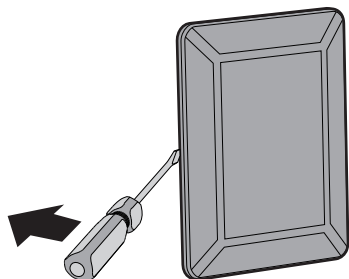

4. Slide out and remove the light bulb.

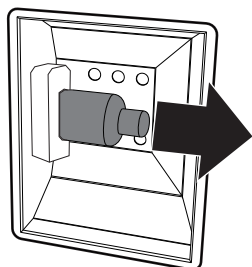

Do not touch the halogen light bulb directly with your fingers, but wrap it in insulating material.

5. Fit the new light bulb.

6. Refit the cover. Ensure the moulded part of the glass (A) is facing the door.

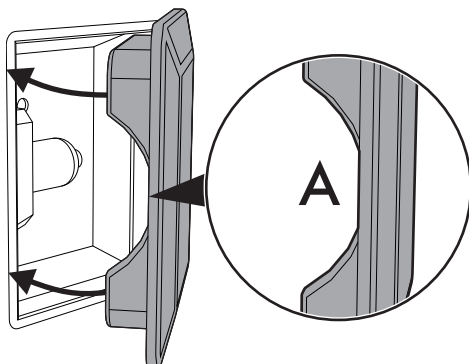

7. Press the cover completely down so that it attaches perfectly to the bulb support.

Removing and installing the oven seal

To remove the oven seal:

- Unhook the clips in the 4 corners and in the centre, then pull the oven seal.

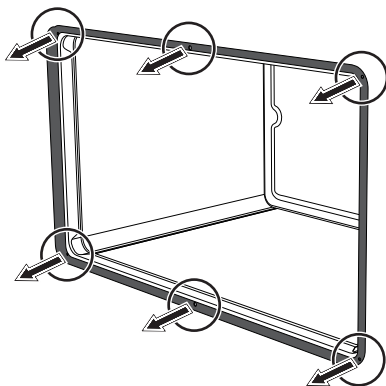

To install the oven seal:

- Hook the clips in the 4 corners and in the centre onto the oven seal.



Oven seal maintenance tips

The seal should be soft and elastic.

To keep the oven seal clean, use a non-abrasive sponge and lukewarm water to wash it.

What to do if...

The appliance does not work.

- The circuit breaker is faulty: look in the fuse box and check that the circuit breaker is in working order.
- Power cut: check whether the kitchen light works.

The gas burner does not ignite.

- Power cut or damp ignition plugs: light the gas burner with a gas lighter or a match.

The oven does not heat up.

- Faulty fuse: check and, if required, replace the circuit breaker.
- The function knob has not been set: set the function knob.

All dishes that are prepared in the oven burn within an extremely short period of time.

- Faulty thermostat: call the Authorised Assistance Centres.

The door panel steams up when the oven is hot.

- Normal occurrence caused by the difference in temperature: this has no effect on oven performance.



If the problem has not been resolved or in the case of other types of fault, contact your local technical support centre.



Annual service by an authorised person is recommended, or if any of the following conditions are noticed:

- Incomplete ignition.
- appreciable yellow tipping.
- carbon deposition.
- lifting.
- floating.
- lighting back.
- objectionable odour.



5 Installation

5.1 Minimum clearance to combustible surfaces

Freestanding cooker

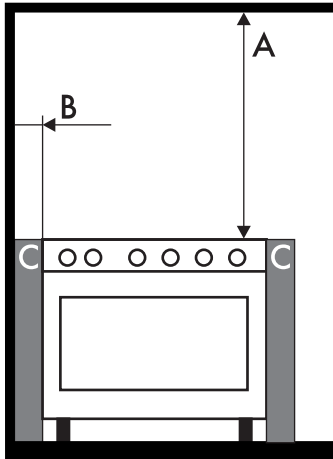

A 600 mm (Overhead) measured from the highest part of the highest burner and 750 mm for an exhaust fan.

B 200 mm (Vertical combustible surface) measured from the edge of the nearest burner.

C 10 mm (Horizontal combustible surface) below the hob.

Maximum height of the top pan support with respect to the surface that supports the appliance is 912mm.



Refer to AS/NZS 5601 (Protection of a combustible surface) if the above minimum clearances cannot be achieved.



The appliance connection point shall be accessible with the appliance installed.

5.2 Gas connection



Gas leak
Danger of explosion

- After carrying out any operation, check that the tightening torque of gas connections is between 10 Nm and 15 Nm.
- If required, use a pressure regulator that complies with current regulations.
- At the end of the installation, check for any leaks with a soapy solution, never with a flame.
- Installation with flexible hose must be carried out so that the length of the piping does not exceed 1,2 metres when fully extended; make sure that the hoses do not come into contact with moving parts and that they are not crushed in any way.
- The hoses should not come into contact with moving parts and should not be crushed in any way.



General informations

This appliance is suitable for installation with Natural Gas or ULPG (propane/butane). Refer to "Burner and nozzle characteristics table" paragraph for the relevant burner pressure and appropriate injector sizes. When the appliance is to be connected to Natural Gas then the pressure regulator supplied must be fitted to the gas inlet. A test point (for checking the gas pressure) is supplied either with the regulator or as a separate fitting in the case of ULPG (propane) appliances.

Connection of the appliance to the gas supply must be in accordance with the requirements of AS5601. A 1/2" BSP connector at the inlet is recommended and the gas supply line to the appliance must be of adequate length to allow sufficient withdrawal of appliance for service or disconnection and be:

1. annealed copper pipe or;
2. flexible hose according to AS/NZ1869 & be at least Class "B", 10 mm diameter.

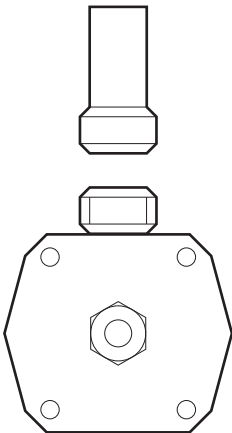

The appliance must be installed with provision to allow the gas to be turned off and disconnected for servicing and removal of the appliance as required from the gas supply. Before the appliance is operated make certain all relevant parts are placed in the correct position.

On completion of the installation, the installer **MUST** check for gas leaks and test each burner individually for the correct flame. Once all burners have been tested individually, turn all burners on together. Warranty service calls do not cover these adjustments!

To check the operating pressure of the appliance it is recommended at least 2 large size burners are used. Ensure appliance is secured to wall when installation is completed.

N.G. The regulator supplied must be fitted to the 1/2 BSP thread at the rear of the appliance. An approved manual shut-off valve must be installed. The N.G. regulator must be checked and adjusted to 1.0kPa after installation.

U.L.P.G. Can be connected to the inlet fitting directly. Gas pressure must be checked to confirm the appliance operating pressure is 2.75kPa, the appliance test point is the Rapid burner injector as shown below.

1. Disconnect power.
2. Light the auxiliary burner and set to high flame. Ensure all other burners are off.



Installation

- Zero manometer, then apply 6 mm flexible tubing (A) to seal over the Rapid burner injector (B) and check the gas pressure by pressing in the corresponding burner control knob in, then turning to high flame position.

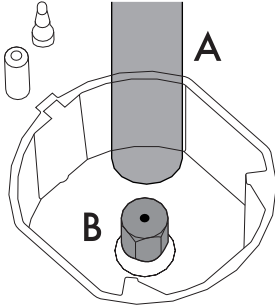

Patent 2015101170. For inquires contact Gas Approval consulting Pty Ltd. Smeg license 037 for GSCS20265

Room ventilation

The room containing the appliance should have a permanent air supply in accordance with the standards in force. The room where the appliance is installed must have enough air flow needed for the regular combustion of gas and the necessary air change in the room itself. The hob shall be installed in rooms with natural ventilation, as required by Standards regulations AS/NZS5601.

Combustion gas discharge

Combustion gases may be discharged by means of hoods connected to a flue with reliable natural draught, or a fan extraction system. An effective extraction system requires careful design by an authorised specialist, and must comply with the regulation distances and positions. After installation, the engineer must issue a certificate of compliance.

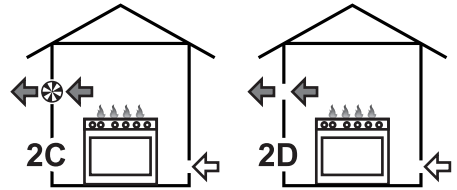
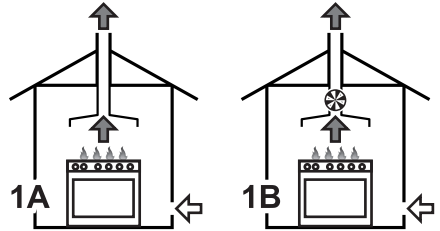

- Extraction using a hood.
- Extraction without a hood.

- A Single natural draught chimney.
- B Single chimney with extractor fan.
- C Directly outdoors with wall- or window-mounted extractor fan.
- D Directly outdoors through wall.

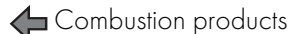



5.3 Adaptation to different types of gas

i The appliance is pre-set for natural gas at a pressure of 1.0 kPa.

In case of operation with other types of gas, the burner nozzles must be changed and the minimum flame adjusted on the gas taps.

Replacing nozzles

1. Remove the pan stands, burner caps and flame-spreader crowns to access the burner casings.
2. Replace the nozzles using a 7 mm socket wrench according to the gas to use (see "Burner and nozzle characteristics table").

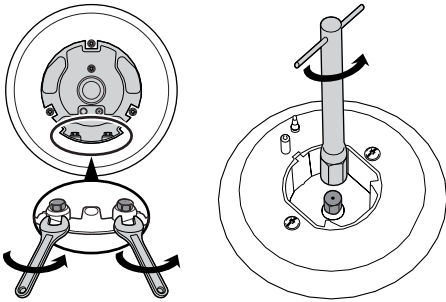

3. Replace the burners in the correct position.

Adjusting the minimum setting for natural or city gas

Light the burner and turn it to the minimum position. Extract the gas tap knob and turn the adjustment screw next to the tap rod (depending on the model) until the correct minimum flame is achieved.

Refit the knob and verify that the burner flame is stable.

Turn the knob rapidly from the maximum to the minimum setting: the flame should not go out. Repeat the operation on all gas taps.

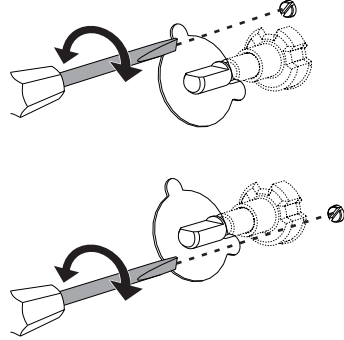

Adjusting the minimum setting for LPG

Tighten the screw located at the side of the tap rod clockwise all the way.



Following adjustment to a gas other than the one originally set in the factory, replace the gas setting label fixed to the appliance with the one corresponding to the new gas. The label is inserted inside the nozzle pack (where present).

Lubrication of gas taps

Over time the gas taps may become difficult to turn and get blocked. Clean them internally and replace the lubrication grease.



The greasing of the gas taps should be performed by a specialised technician.



Installation

Burner and nozzle characteristics table

NG 1.0 kPa	AUX	SR	R	DUAL (int + ext)
Nominal gas consumption (MJ/h)	3.9	7.5	12	17.0
Injector (1/100 mm)	90	120	155	81 + 170
ULPG 2.75 kPa	AUX	SR	R	DUAL (int + ext)
Nominal gas consumption (MJ/h)	3.9	6.3	10.8	17.0
Injector (1/100 mm)	54	68	88	48 + 100

Appliance dimensions (mm)

Location of gas and electrical connection points.

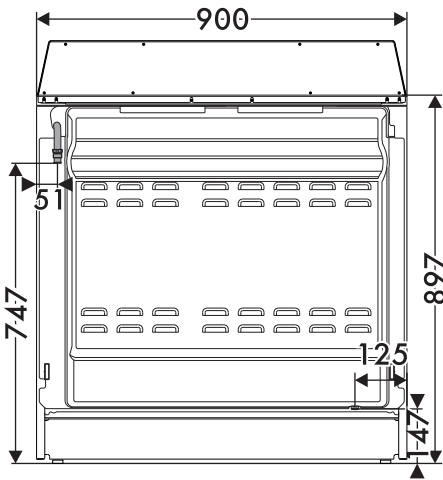

5.4 Positioning



Heavy appliance
Danger of crush injuries

- Place the appliance into the piece of furniture with the aid of a second person.



Pressure on the open door
Risk of damages to the appliance

- When positioning the appliance during installation, do not use the door handle to lift up or move this appliance.
- Never use the oven door to lever the appliance into place when fitting.
- Avoid exerting too much pressure on the oven door when open.



Heat production during appliance operation
Risk of fire

- Veneers, adhesives or plastic coatings on adjacent furniture should be temperature-resistant (no less than 90°C).



Positioning and levelling



**Heavy appliance
Risk of damage to the appliance**

- Insert the front feet first and then the rear ones.

Properly level the appliance on the floor to ensure better stability.

- After making the electrical and/or gas connections, screw or unscrew the bottom part of the foot until the appliance is stable and level on the floor.

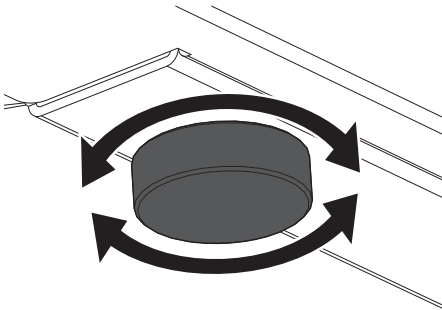

Assembling the skirt



The backguard provided is an integral part of the product; it must be fastened to the appliance prior to installation.

The backguard must always be positioned and secured correctly on the appliance.

1. Loosen the 6 screws on the back of the top (A) and unscrew the 2 screws (B) on the side part of the backguard.

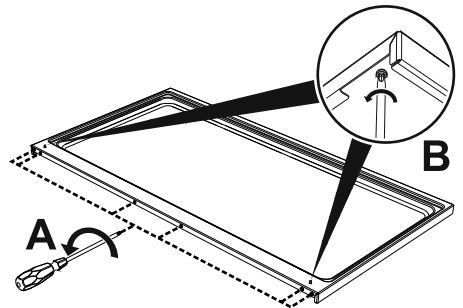

2. Place the backguard on the top. Align the 6 bottom slots of the backguard with the 6 screws on the back of the top that were previously loosened.
3. Tighten the 6 screws on the back of the hob (A) and tighten the 2 screws under the top (B) to secure the backguard.

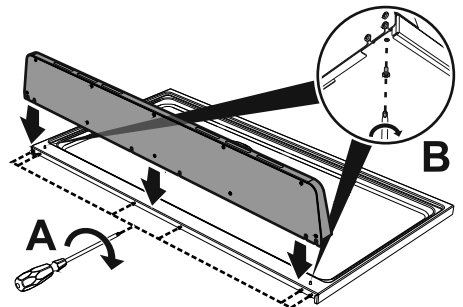



Installation

Mounting the toe skirt

i The toe skirt provided is an integral part of the product; it must be fastened to the appliance prior to installation.

The toe skirt must always be positioned and secured correctly on the appliance.

1. Open the storage compartment.

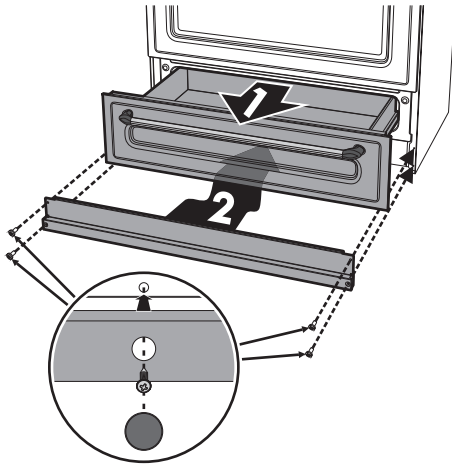

2. Place the toe skirt in the front bottom part of the appliance.
3. Screw the four side screws to fasten the toe skirt to the appliance.
4. Cover the holes of the toe skirt with the plugs provided.

Wall fixing

1. Turn the screw placed behind the cooktop near the gas connection.

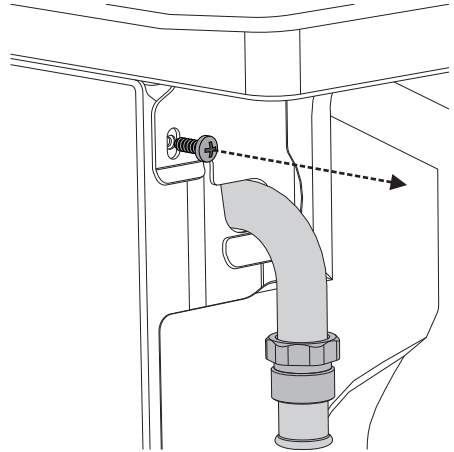

2. Attach the chain to the cooker with the screw just removed.

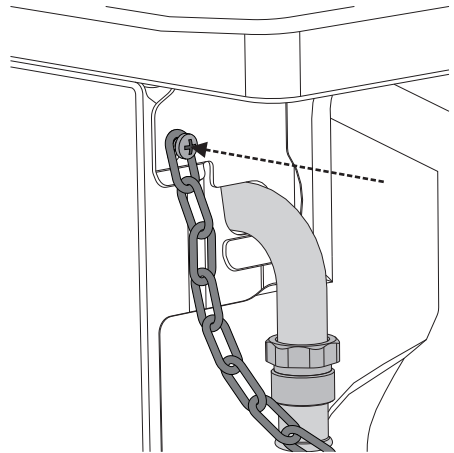

3. Stretch it out horizontally so that the other end of the chain touches the wall.



4. Mark the wall in the position where the hole is to be drilled.

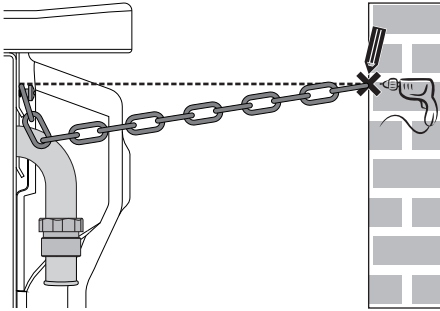

5. Drill the hole and insert a wall plug.

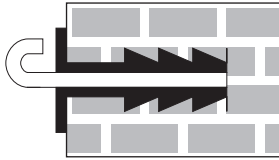

6. Attach the chain and push the appliance to the wall.

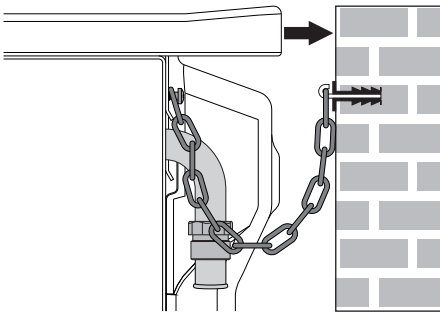

The chain length must be as short as practicable to avoid appliance tilting forward and also diagonal to avoid appliance moving sideways.

5.5 Electrical connection



**Power voltage
Danger of electrocution**

- Have the electrical connection performed by authorised technical personnel.
- Use personal protective equipment.
- The appliance must be connected to earth in compliance with electrical system safety standards.
- Disconnect the mains supply.
- Do not pull the cable to remove the plug.
- Use cables withstanding a temperature of at least 90°C.
- The tightening torque of the screws of the terminal board conductors must be 1.5 - 2 Nm.

General information

Check the grid characteristics against the data indicated on the plate. The identification plate bearing the technical data, serial number and brand name is visibly positioned on the appliance. Do not remove this plate for any reason. Perform the ground connection using a wire that is 20 mm longer than the other wires.



Installation

The appliance can work in the following modes:

- **220-240 V 1N~**

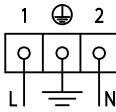

use a **3 x 1,5 mm² three-core** cable.



The values indicated above refer to the cross-section of the internal conductor.



The aforementioned power cables are sized taking into account the coincidence factor (in compliance with standard EN 60335-2-6).

Fixed connection

Fit the power line with an omnipolar circuit breaker in compliance with installation regulations. The circuit breaker should be located near the appliance and in an easily reachable position.

Connection with plug and socket

Make sure that the plug and socket are of the same type.

Avoid use of adapters and shunts as these could cause overheating and a risk of burns.

5.6 For the installer

- The plug must remain accessible after the installation is complete. Do not kink or trap the mains connection cable.
- The appliance must be fitted according to the installation diagrams.
- Do not attempt to turn or stress the threaded elbow on the manifold. You risk damage to this part of the appliance which may void the manufacturer's warranty.
- Before leaving check all connections for gas leaks with soap and water. **DO NOT** use a naked flame for detecting leaks.
- Ignite all burners individually and concurrently to ensure correct operation of the gas valves, burner and ignition.
- Turn the gas knobs to the low position and observe stability of the flame for each burner individually and all together.
- In case the appliance fails to operate correctly after all checks have been carried out, refer to the Authorised Assistance Centre in your area.
- When satisfied with the appliance, please instruct the user on the correct method of operation.



914777490/F

IN CASE OF ABNORMAL OPERATION SUCH AS FAILURE TO LIGHT OR YELLOW FLAMES CONTACT YOUR LOCAL DEALER FOR SERVICE ATTENTION.

CIRCUIT DIAGRAM

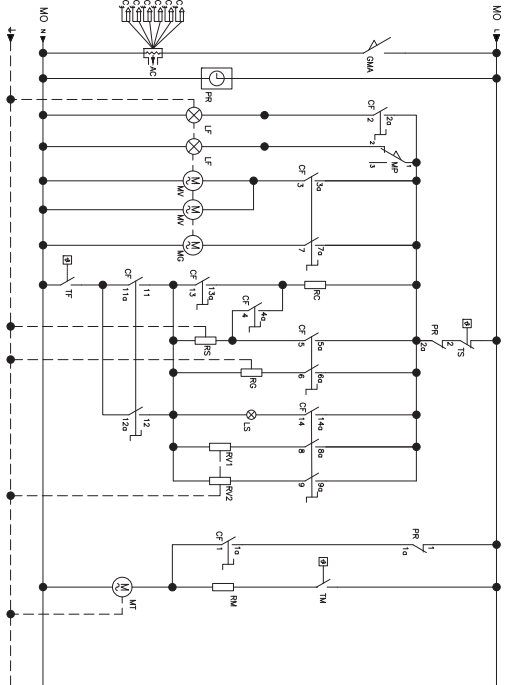

LEGEND	
CF	SELECTOR SWITCH CONTACTS
MO	TERMINAL STRIP
PR	ELECTRONIC PROGRAMMER
MP	DOOR LIMIT SWITCH
TS	THERMAL CUT-OUT
AC	SPARK IGNITER
GMA	SPARK IGNITER MICROSWITCH
TF	OVEN THERMOSTAT
MW	COOKING FAN MOTOR
MG	ROASTING SPIT DRIVE MOTOR
TM	COOLING FAN MOTOR THERMOSTAT
RM	FAN MOTOR RESISTOR
RS	LOWER HEATING ELEMENT
RC	UPPER HEATING ELEMENT
RG	BROIL-GRILL ELEMENT
RV	CIRCULAR HEATING ELEMENT
TAM	COOLING FAN CONTROL THERMOSTAT
LF	COOKER LAMP
LS	SIGNALING LAMP
C	SPARK PLUGS
MT	COOLING FAN MOTOR
L	PHASE
N	NEUTRAL

92 849 B700

WARNING: STABILISING MEANS MUST BE FITTED TO THIS PRODUCT. REFER TO INSTRUCTIONS.

ADJUSTED FOR NATURAL GAS 1.0 kPa

THIS COOKER IS SUITABLE FOR
A HOSE ASSEMBLY INSTALLATION.

WARNING: 240 V ac
DISCONNECT POWER BEFORE SERVICING UNIT.

TO BE INSTALLED BY AN AUTHORIZED PERSON ONLY

The manufacturer reserves the right to make any changes deemed useful for improvement of his products without prior notice. The illustrations and descriptions contained in this manual are therefore not binding and are merely indicative.

Where the data plate is obscured by cabinetry when the cooker is in the installed position, place the supplied duplicate data plate to a suitable adjacent surface or here within this instruction manual for future reference.



914777490/F