

Nugget Ice Machines

CNF201 & CNF202 Models

Installation, Operation and Maintenance Manual



Original Document

 **Caution**

Read this instruction before operating this equipment.

Safety Notices

Safety Notices

Read these precautions to prevent personal injury:

- Read this manual thoroughly before operating, installing or performing maintenance on the equipment. Failure to follow instructions in this manual can cause property damage, injury or death.
- Routine adjustments and maintenance procedures outlined in this manual are not covered by the warranty.
- Proper installation, care and maintenance are essential for maximum performance and trouble-free operation of your equipment. Visit our website www.manitowocice.com for manual updates, translations, or contact information for service agents in your area.
- This equipment contains high voltage electricity and refrigerant charge. Installation and repairs are to be performed by properly trained technicians aware of the dangers of dealing with high voltage electricity and refrigerant under pressure. The technician must also be certified in proper refrigerant handling and servicing procedures. All lockout and tag out procedures must be followed when working on this equipment.
- This equipment is intended for indoor use only. Do not install or operate this equipment in outdoor areas.

DEFINITIONS

DANGER

Indicates a hazardous situation that, if not avoided, will result in death or serious injury. This applies to the most extreme situations.

Warning

Indicates a hazardous situation that, if not avoided, could result in death or serious injury.

Caution

Indicates a hazardous situation that, if not avoided, could result in minor or moderate injury.

Notice

Indicates information considered important, but not hazard-related (e.g. messages relating to property damage).

Warning

Follow these precautions to prevent personal injury during installation of this equipment:

- Installation must comply with all applicable equipment fire and health codes with the authority having jurisdiction.
- To avoid instability the installation area must be capable of supporting the combined weight of the equipment and product. Additionally the equipment must be level side to side and front to back.
- Remove all removable panels before lifting and installing and use appropriate safety equipment during installation and servicing. Two or more people are required to lift or move this appliance to prevent tipping and/or injury.
- Connect to a potable water supply only.
- Do not damage the refrigeration circuit when installing, maintaining or servicing the unit.

Warning

Follow these electrical requirements during installation of this equipment.

- All field wiring must conform to all applicable codes of the authority having jurisdiction. It is the responsibility of the end user to provide the disconnect means to satisfy local codes. Refer to rating plate for proper voltage.
- This appliance must be grounded.
- This equipment must be positioned so that the plug is accessible unless other means for disconnection from the power supply (e.g., circuit breaker or disconnect switch) is provided.
- Check all wiring connections, including factory terminals, before operation. Connections can become loose during shipment and installation.

NOTE: Indicates useful, extra information about the procedure you are performing.

⚠ DANGER

Do not operate equipment that has been misused, abused, neglected, damaged, or altered/modified from that of original manufactured specifications. This appliance is not intended for use by persons (including children) with reduced physical, sensory or mental capabilities, or lack of experience and knowledge, unless they have been given supervision concerning use of the appliance by a person responsible for their safety. Do not allow children to play with, clean or maintain this appliance without proper supervision.

⚠ Warning

Follow these precautions to prevent personal injury while operating or maintaining this equipment:

- Read this manual thoroughly before operating, installing or performing maintenance on the equipment. Failure to follow instructions in this manual can cause property damage, injury or death.
- Crush/Pinch Hazard. Keep hands clear of moving components. Components can move without warning unless power is disconnected and all potential energy is removed.
- Moisture collecting on the floor will create a slippery surface. Clean up any water on the floor immediately to prevent a slip hazard.
- Objects placed or dropped in the bin can affect human health and safety. Locate and remove any objects immediately.
- Never use sharp objects or tools to remove ice or frost. Do not use mechanical devices or other means to accelerate the defrosting process.
- When using cleaning fluids or chemicals, rubber gloves and eye protection (and/or face shield) must be worn.

⚠ DANGER

Follow these precautions to prevent personal injury during use and maintenance of this equipment:

- It is the responsibility of the equipment owner to perform a Personal Protective Equipment Hazard Assessment to ensure adequate protection during maintenance procedures.
- Do Not Store Or Use Gasoline Or Other Flammable Vapors Or Liquids In The Vicinity Of This Or Any Other Appliance. Never use flammable oil soaked cloths or combustible cleaning solutions for cleaning.
- All covers and access panels must be in place and properly secured when operating this equipment.
- Risk of fire/shock. All minimum clearances must be maintained. Do not obstruct vents or openings.
- Failure to disconnect power at the main power supply disconnect could result in serious injury or death. The power switch DOES NOT disconnect all incoming power.
- All utility connections and fixtures must be maintained in accordance with the authority having jurisdiction.
- Turn off and lockout all utilities (electric, water) according to approved practices during maintenance or servicing.
- Never use a high-pressure water jet for cleaning on the interior or exterior of this unit. Do not use power cleaning equipment, steel wool, scrapers or wire brushes on stainless steel or painted surfaces.
- Two or more people are required to move this equipment to prevent tipping.
- These units must be tethered/secured to comply with all applicable codes.
- The on-site supervisor is responsible for ensuring that operators are made aware of the inherent dangers of operating this equipment.
- Do not operate any appliance with a damaged cord or plug. All repairs must be performed by a qualified service company.

Table of Contents

Safety Notices

Safety Notices	3
Definitions	3

Section 1 General Information

Model Numbers	7
Accessories	7
Manitowoc Cleaner and Sanitizer	7
Legs	7
Touchless Sensing Option.....	7

Section 2 Installation

Location of Ice Machine	9
Ice Machine Clearance Requirements	9
Sealing to Countertop or Stand	9
Electrical Service	10
Voltage	10
Fuse/Circuit Breaker.....	10
Total Circuit Ampacity	10
Electrical Specifications	10
Water Supply and Drains	10
Potable Water Supply.....	10
Potable Water Inlet Lines	10
Drain Connections.....	10
Water Supply & Drain Line Sizing Connections	11
Before Starting the Ice Machine	12
Installation Checklist	12



**Section 3
Operation**

Sequence of Operation 13
 15 Minute Time Delay 13
 Prior to Start-up 13
 Initial Start-up 13
 Freeze Cycle..... 13
 Automatic Shutoff 13
 Restart After Automatic Shutoff..... 13
Operational Checks 14
 General..... 14
 Operation 14

**Section 4
Maintenance**

Cleaning and Sanitizing..... 15
 General..... 15
 Exterior Cleaning 15
 Procedures 15
 Preventative Maintenance Cleaning Procedure 16
 Procedure to Clean Heavily Scaled Flake/Nugget Ice Machines 17
 Cleaning Procedure 17
 Sanitizing Procedure 18
Component Disassembly for Cleaning/Sanitizing 19
Cleaning the Condenser..... 22
Removal from Service/Winterization 23
 General..... 23

**Section 5
Troubleshooting**

Checklist..... 25



Section 1

General Information

Model Numbers

This manual covers the following models:

Lever Activated	Touchless Sensor Activated
CNF201A-161L CNF201A-251L	CNF201A-161 CNF201A-251 CNF0201-261
CNF202A-161L CNF202A-251L	CNF202A-161 CNF202A-251 CNF0202-261

Accessories

MANITOWOC CLEANER AND SANITIZER

Manitowoc Ice Machine Cleaner and Sanitizer are available in convenient 16 oz. (473 ml) and 1 gal (3.78 l) bottles. These are the only cleaner and sanitizer approved for use with Manitowoc products.

Cleaner Part Number	Sanitizer Part Number
16 oz. (473 ml) 000000084	16 oz. (473 ml) 94-0565-3
	1 Gallon (3.78 l) 94-0581-3

LEGS

Optional four inch adjustable legs are available.

TOUCHLESS SENSING OPTION

Touchless sensing can be ordered installed on the ice machine from the factory or a field conversion kit is available. The field conversion kit includes a replacement front panel and instructions for installation.



THIS PAGE INTENTIONALLY LEFT BLANK



Section 2 Installation

These instructions are provided to assist the qualified installer. Check your local Yellow Pages for the name of the nearest Manitowoc distributor, or call Manitowoc Foodservice for information regarding start-up services.

Important

Failure to follow these installation guidelines may affect warranty coverage.

Location of Ice Machine

The location selected for the ice machine must meet the following criteria. If any of these criteria are not met, select another location.

- The location must be free of airborne and other contaminants.
- The air temperature must be at least 45°F (7°C), but must not exceed 110°F (43°C).
- The water temperature must be at least 45°F (7°C), but must not exceed 90°F (32°C).
- The location must not be near heat-generating equipment or in direct sunlight.
- The location must be capable of supporting the weight of the ice machine and a full bin of ice and allow the ice machine to be level front to back and side to side.
- The location must allow enough clearance for water and electrical connections in the **rear of the ice machine**. The drain can be routed out the rear or bottom of dispenser.
- The location must not obstruct airflow through or around the ice machine. Airflow is in the left side and out the top. Refer to chart for clearance requirements.

These ice machines are intended for use in household and similar applications such as:

- Staff kitchen areas in shops, offices and other work environments.
- Clients in hotels, motels, farmhouses, bed and breakfast and other residential type environments.
- Catering and similar non-retail applications.

Caution

To avoid instability the ice machine must be installed in an area capable of supporting the weight of the ice machine and a full bin of ice.

Ice Machine Clearance Requirements

	CNF201	CNF202
Top	24" (61 cm)	24" (61 cm)
Sides	8" (20 cm)	8" (20 cm)
Back*	5" (13 cm)	5" (13 cm)

* 5" (13 cm) is recommended for servicing the ice machine. Clearance can be 0" when water and drain connections exit the bottom of the ice machine.

Notice

The ice machine must be protected if it will be subjected to temperatures below 32°F (0°C). Failure caused by exposure to freezing temperatures is not covered by the warranty. See "Removal from Service/Winterization".

SEALING TO COUNTERTOP OR STAND

Ice machines installed without legs must be sealed to the countertop or stand. This prevent liquids or debris from infiltrating beneath the ice machine.

Electrical Service

⚠ Warning

All wiring must conform to local, state and national codes.

VOLTAGE

The maximum allowable voltage variation is ±10% of the rated voltage on the ice machine model/serial number plate at start-up (when the electrical load is highest).

FUSE/CIRCUIT BREAKER

A separate fuse/circuit breaker must be provided for each ice machine. Circuit breakers must be H.A.C.R. rated (does not apply in Canada).

115/60/1 ice machines are factory pre-wired with a power cord and 5-15P plug.

230/60/1 and 230/50/1 ice machines are factory prewired with a power cord, no plug is supplied.

⚠ Warning

The ice machine must be grounded in accordance with national and local electrical codes.

TOTAL CIRCUIT AMPACITY

The total circuit ampacity is used to help select the wire size of the electrical supply.

The wire size (or gauge) is also dependent upon location, materials used, length of run, etc., so it must be determined by a qualified electrician.

Electrical Specifications

Ice Machine	Voltage/Phase/Cycle	Air-Cooled
		Total Circuit Amps
CNF201	115/1/60	10.3
	230/1/60	
	230/1/50	
CNF202	115/1/60	5.4
	230/1/60	
	230/1/50	

Water Supply and Drains

POTABLE WATER SUPPLY

Local water conditions may require treatment of the water to inhibit scale formation, filter sediment, and remove chlorine odor and taste.

⚠ Warning

PERSONAL INJURY POTENTIAL

For ice making, connect to a potable water supply only.

Important

If you are installing a Manitowoc water filter system, refer to the Installation Instructions supplied with the filter system for ice making water inlet connections.

POTABLE WATER INLET LINES

Follow these guidelines to install water inlet lines:

- Do not connect the ice machine to a hot water supply. Be sure all hot water restrictors installed for other equipment are working. (Check valves on sink faucets, dishwashers, etc.)
- If water pressure exceeds the maximum (80 psig/551.5 kPa) recommended pressure, obtain a water pressure regulator from your Manitowoc distributor.
- Install a water shut-off valve and union for both the ice-making and condenser water lines.
- Insulate water inlet lines to prevent condensation.

DRAIN CONNECTIONS

Follow these guidelines when installing drain lines:

- Drain lines must have a 1.5 inch drop per 5 feet of run (2.5 cm per meter) and must not create traps.
- The floor drain must be large enough to accommodate drainage from all drains.
- Insulate drain lines to prevent condensation.
- Drains must have a union or other suitable means to allow in-place disconnection from the ice machine when servicing is required.



WATER SUPPLY & DRAIN LINE SIZING CONNECTIONS

⚠ Caution
Plumbing must conform to state and local codes.

Location	Water Temperature	Water Pressure	Ice Machine Fitting	Tubing Size Up to Ice Machine Fitting
Ice Making Water Inlet	45°F (6°C) Min. 90°F (32°C) Max.	20 psi (137.9 kPa) Min. 80 psi (551.5 kPa) Max.	3/8" Female Pipe Thread	3/8" (9.5 mm) minimum inside diameter
Ice Machine Drain	---	---	1/2" Female Pipe Thread	3/4" (19 mm) minimum inside diameter

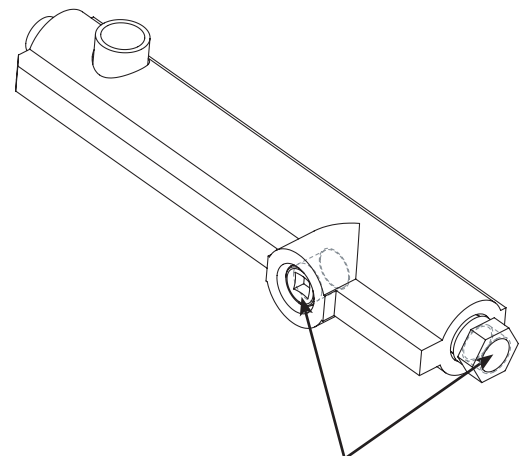
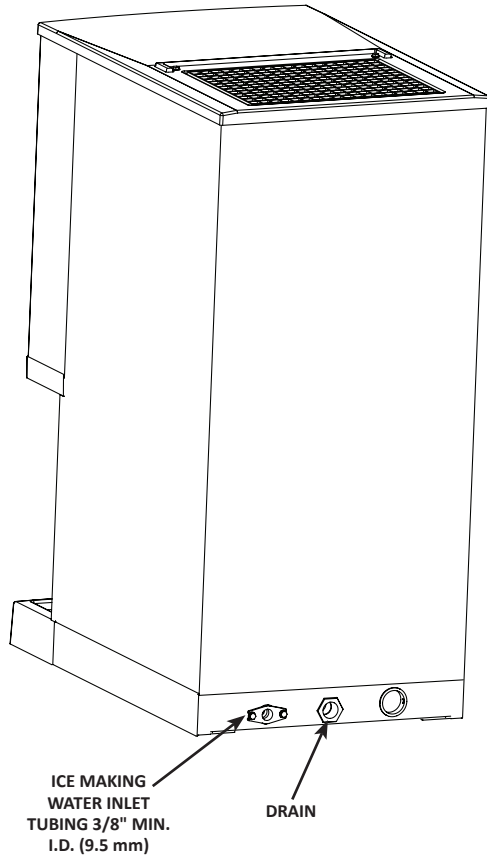

DRAIN CONNECTION IS INTERCHANGEABLE
DRAIN IS PREINSTALLED TO RUN OUT THE BACK
MOVE DRAIN PLUG TO RUN DRAIN OUT THE BOTTOM IF DESIRED

Typical Water Supply Drain Installation



Before Starting the Ice Machine

INSTALLATION CHECKLIST

√	Checklist Item
	Is the ice machine level?
	Have all of the internal packing been removed?
	Have all of the electrical and water connections been made?
	Has the supply voltage been tested and checked against the rating on the nameplate?
	Is there proper clearance around the ice machine for air circulation?
	Has the ice machine been installed where ambient temperatures will remain in the range of 45° – 110°F (7° – 43°C)?
	Has the ice machine been installed where the incoming water temperature will remain in the range of 45° – 90°F (7° – 32°C)?
	Are all electrical leads free from contact with refrigeration lines and moving equipment?
	Has the owner/operator been instructed regarding maintenance and the use of Manitowoc Cleaner and Sanitizer?
	Has the warranty registration card been sent to the factory?
	Has the ice machine and bin been sanitized?
	Has this manual been given to the owner/operator?
	Is the water reservoir approximately 2/3 full of water?
	Has the toggle switch been placed in the ICE position? (Switch is located under front panel ledge)

All Manitowoc ice machines are factory-operated and adjusted before shipment. Normally, new installations do not require any adjustment. To ensure proper operation, follow the Operational Checks in Section 3 of this manual.

Adjustments and maintenance procedures outlined in this manual are not covered by the warranty.

Warning

Potential Personal Injury Situation

Do not operate equipment that has been misused, abused, neglected, damaged, or altered/modified from that of original manufactured specifications.

Section 3

Operation

Sequence of Operation

15 MINUTE TIME DELAY

The 15 minute delay must be expired before the gearmotor or compressor will energize.

The delay period starts to time out upon application of power or movement of the toggle switch from OFF to ICE.

The delay period starts when:

- The ice machine enters Automatic Shutoff
- Power is disconnected and reconnected
- The toggle switch is moved from OFF to ICE

This time delay period can not be overridden and will reset to 15 minutes if any of the above conditions occur.

PRIOR TO START-UP

When the toggle switch is placed in the ICE position, the following must occur in the listed order before ice making will start.

- The ice chute damper must be in the closed or down position.
- The 15 minute delay period must be expired. The delay period starts upon application of power or toggle switch movement from OFF to ICE.
- The water sensing switch must be closed (water reservoir full of water and water sensing float in the up position).

INITIAL START-UP

Applying power and/or moving the toggle switch from OFF to ICE will start a 15 minute delay period. This delay period can not be overridden. With the water sensing switch closed (reservoir full of water) the gear motor will energize at the end of the 15 minute time delay. The compressor and condenser fan motor energize 5 seconds after the gearmotor.

FREEZE CYCLE

The float valve automatically maintains the water level in the reservoir. The ice damper will open and close to verify ice production. The ice machine will continue to make ice until the ice damper is held open (up) as ice fills the bin.

AUTOMATIC SHUTOFF

When the ice damper is held open by ice, the gearmotor, compressor and condenser fan de-energize. The fifteen minute delay period starts to time out. The ice machine will remain off until the 15 minute delay period expires and the ice damper closes.

RESTART AFTER AUTOMATIC SHUTOFF

1. **Less than 4 hours have passed since automatic shut-off.**

With the water sensing switch closed (reservoir full of water), the gear motor will energize at the end of the 15 minute time delay. The compressor and condenser fan motor energize 5 seconds after the gearmotor.

2. **More than 4 hours have passed since automatic shutdown.**

The dump valve energizes to drain the evaporator. After 30 seconds the dump valve de-energizes. When the reservoir fills with water, the water sensing switch closes and the gearmotor energizes. The compressor and condenser fan motor energize 5 seconds after the gearmotor.

Operational Checks

GENERAL

Manitowoc ice machines are factory-operated and adjusted before shipment. Normally, a newly installed ice machine does not require any adjustment.

To ensure proper operation, always follow the Operational Checks:

- when starting the ice machine for the first time
- after a prolonged out-of-service period
- after cleaning and sanitizing

NOTE: Routine adjustments and maintenance procedures outlined in this manual are not covered by the warranty.

Blue Light

The blue light on the dispensing spout is energized when the toggle switch is in the ICE position and the ice machine is operational. If the light is not energized the ice machine will not make ice. Refer to Section 5 Troubleshooting if the ice machine has power and the light will not energize.

Toggle Switch

The toggle switch must be placed in the ICE position to make ice.

Water Reservoir

The water reservoir must be 2/3 full of water and the water sensing float must be up (switch closed) before the ice machine will start.

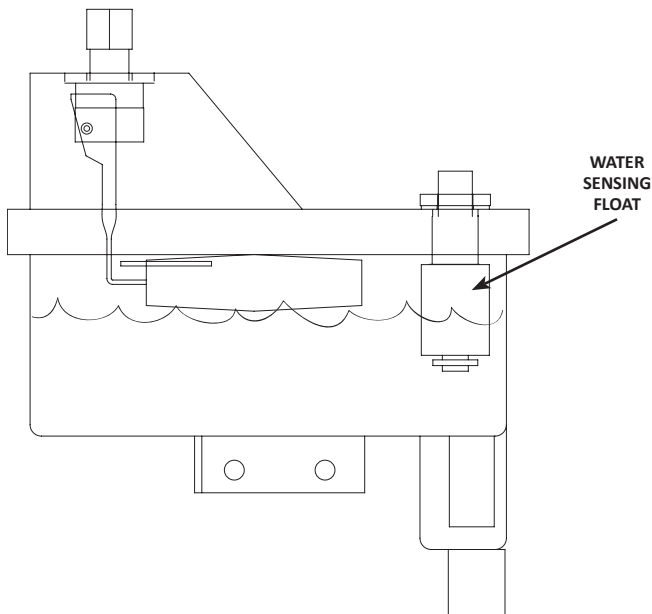

Ice Production

Allow the ice machine to produce ice for 15 minutes before testing the dispense mechanism. This will ensure a sufficient quantity of ice in the bin for dispensing.

OPERATION

1. Set Selector Switch (When Used)

Depress the button adjacent to the text.

- Select ICE for ice dispense only
- Select ICE/WATER for water and ice
- Select WATER for water only

2. Dispense

LEVER-ACTIVATED

Use glass or container to press dispenser arm backward. Release the arm and the ice machine will stop dispensing.

TOUCHLESS CENTER-ACTIVATED

Place a glass or container underneath the dispensing spout within 1" (2.5 cm) of the sensor. The ice machine will automatically dispense. Remove the glass or container to stop dispensing.

Section 4

Maintenance

Cleaning and Sanitizing

GENERAL

You are responsible for maintaining the ice machine in accordance with the instructions in this manual. Maintenance procedures are not covered by the warranty.

Clean and sanitize the ice machine every six months for efficient operation. If the ice machine requires more frequent cleaning and sanitizing, consult a qualified service company to test the water quality and recommend appropriate water treatment. If required, an extremely dirty ice machine may be taken apart for cleaning and sanitizing.

Caution

Use only Manitowoc approved Ice Machine Cleaner (part number 000000084) and Sanitizer (part number 94-0565-3). Do not mix Cleaner and Sanitizer solutions together. It is a violation of Federal law to use these solutions in a manner inconsistent with their labeling. Read and understand all labels printed on bottles before use.

Warning

Wear rubber gloves and safety goggles (and/or face shield) when handling Ice Machine Cleaner or Sanitizer.

EXTERIOR CLEANING

Weekly: remove grill from scrap ice tray and wipe splash panel, scrap ice tray and grill with sanitizer and water solution (refer to page 18). Pour excess solution in scrap ice tray to clear drain.

TOUCHLESS SENSOR ONLY

Wipe sensor window with a soft cloth and mild detergent. Rinse with clear water and dry with a clean soft cloth.

PROCEDURES

This Manitowoc ice machine has three separate cleaning procedures.

Preventative Maintenance Cleaning Procedure

Perform this procedure as required for your water conditions. Recommended monthly.

- Allows cleaning the ice machine without removing all of the ice from the bin
- Removes mineral deposits from areas or surfaces that are in direct contact with water during the freeze cycle (reservoir, evaporator, auger, drain lines)

Cleaning/Sanitizing Procedure

This procedure must be performed a minimum of once every six months.

- All ice must be removed from the bin
- The ice machine and bin must be disassembled cleaned and sanitized
- The ice machine produces ice with the cleaner and sanitizer solutions
- All ice produced during the cleaning and sanitizing procedures must be discarded

Heavily Scaled Cleaning Procedure

Perform this procedure if you have some or all of these symptoms.

- Grinding, popping or squealing noises from the evaporator
- Grinding noise from gearbox
- Ice machine stops on Safety Shutdown
- Your water has a high concentration of minerals
- The ice machine has not been on a regular maintenance schedule

Run a cleaning procedure as described above after this procedure is complete.

NOTE: A Sanitizing Procedure must be performed after all cleaning procedures have been completed.

PREVENTATIVE MAINTENANCE CLEANING PROCEDURE

Ice machine cleaner is used to remove lime scale or other mineral deposits. It is not used to remove algae or slime. Refer to “Sanitizing Procedure” for removal of algae and slime. To initiate a cleaning cycle using Manitowoc’s Cleaning Technology use the following procedure.

Step 1 To start a cleaning cycle, move the toggle switch to the CLEAN position. Water will flow through the water dump valve and down the drain.

Step 2 Remove the top panel and translucent plastic ice chute cover. Wait about one minute then add the proper amount of Manitowoc Ice Machine Cleaner. Rinse the cleaner from the top of the evaporator with 2 ounces (60 ml) of clear water and re-install cover.

Model	Amount of Cleaner
CNF201 CNF202	2 ounce (60 ml)

! Caution

Use only Manitowoc approved Ice Machine Cleaner. It is a violation of Federal law to use these solutions in a manner inconsistent with their labeling. Read and understand all labels printed on bottles before use.

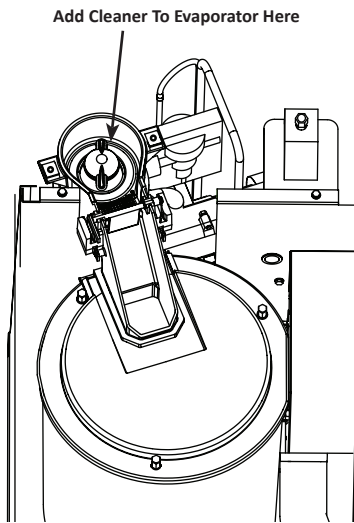

Step 3 The ice machine will run a wash cycle, a series of rinse cycles and then stop. This entire cycle lasts approximately 30 minutes.

NOTE: Periodic cleaning must be performed on adjacent surface areas not contacted by the water distribution system.

NOTE: The ice machine may be set to start and finish a cleaning procedure, and then automatically start ice making again.

- A. After cleaner is added, move the switch from CLEAN to ICE position.
- B. When the cleaning cycle is complete, ice making will start automatically.

Changing toggle switch position during clean cycle:

1. Less than 60 seconds into Clean cycle - The Clean cycle will end when the toggle switch is moved to the OFF position.
 2. More than 60 seconds into Clean cycle - The ice machine will complete the Clean cycle. Toggle switch position will determine the next cycle after the Clean cycle is completed.
- CLEAN POSITION - The ice machine will wait for a change in toggle switch position.
 - OFF POSITION - The ice machine will wait for a change in toggle switch position.
 - ICE POSITION - The ice machine will start making ice automatically.

Manitowoc recommends disassembling, cleaning and sanitizing the ice machine and dispenser every six months.



PROCEDURE TO CLEAN HEAVILY SCALED FLAKE/NUGGET ICE MACHINES

Ice machines that are heavily scaled or have not been cleaned on a regular basis will need to run this procedure. Failure to do so may result in binding of the auger as the lime scale releases from the auger and evaporator barrel.

Step 1 Remove panels and set the ICE/OFF/CLEAN toggle switch to the OFF position.

Step 2 Remove all ice from the bin.

Step 3 Turn off the water supply to the ice machine.

Step 4 Place ICE/OFF/CLEAN toggle switch in the CLEAN position. The dump valve will open and drain the water from the evaporator and reservoir.

Step 5 Wait approximately 30 seconds (or until the evaporator is drained) and place the toggle switch in the OFF position.

Step 6 Refer to chart and add the correct amount of cleaner for your model ice machine.

Model	Amount of Cleaner
CNF201 CNF202	12 ounce (355 ml)

Step 7 Turn on the water supply to the ice machine.

Important
Leave the cleaner/water solution in the evaporator for a minimum of 4 hours.

Step 8 Move the toggle switch to the ICE position. The compressor will energize and produce ice with the cleaning solution. Continue the freeze cycle for 15 minutes.

Step 9 Move the toggle switch to the OFF position, then follow the standard cleaning (page 17) and sanitizing procedures (page 18).

CLEANING PROCEDURE

Ice machines that are heavily scaled or have not been cleaned on a regular basis will need to run the Heavily Scaled Cleaning Procedure before this one. Failure to do so may result in binding of the auger as the lime scale releases from the auger and evaporator barrel.

Ice machine cleaner is used to remove lime scale or other mineral deposits. It is not used to remove algae or slime. Refer to the "Sanitizing Procedure" for removal of algae and slime.

Step 1 Remove panels and set the ICE/OFF/CLEAN toggle switch to the OFF position.

Step 2 Turn off the water supply to the ice machine.

Step 3 Remove all ice from the bin.

Step 4 Place ICE/OFF/CLEAN toggle switch in the CLEAN position. The dump valve will open and drain the water from the evaporator and reservoir.

Step 5 Wait approximately 30 seconds (or until the evaporator is drained) and place the toggle switch in the OFF position.

Step 6 Refer to chart and premix the correct solution of cleaner and cool water for your ice machine.

Model	Amount of Cleaner Part Number	Amount of Water
CNF201 CNF202	000000084 2 ounces (60 ml)	32 ounces (1 liter)



Step 7 Remove the top cover from the ice chute and pour the cleaner/water solution into the evaporator. Add the entire amount of premixed solution (excess solution will exit through the overflow tube in the water reservoir).

Step 8 Replace the ice chute cover and allow the ice machine to stand for 30 minutes.

Step 9 Turn on the water supply to the ice machine.

Step 10 Move the toggle switch to the ICE position. After the 15 minute delay period expires, the compressor will energize and produce ice with the cleaning solution.

Step 11 The ice machine will freeze and discharge the cleaning solution into the bin. Allow the cycle to run for 15 minutes.

Step 12 Place the toggle switch in the OFF position and refer to sanitizing procedure.

NOTE: Discard all ice produced during the cleaning process. Cleaning and sanitizing must be performed on adjacent surface areas not contacted by the water distribution system. Refer to Component Disassembly for Cleaning/Sanitizing (page 19) - Disassemble, clean and sanitize the ice machine a minimum of once every six months.

SANITIZING PROCEDURE

Ice machine sanitizer is used to remove algae or slime. It is not used to remove lime scale or other mineral deposits. Refer to the "Cleaning Procedure" for removal of lime scale or other mineral deposits.

NOTE: Sanitizing must be performed on adjacent surface areas not contacted by the water distribution system. Always perform Component Disassembly for Cleaning/Sanitizing procedure and a Cleaning Procedure before sanitizing the ice machine.

Step 1 Turn off the water supply to the ice machine.

Step 2 Place ICE/OFF/CLEAN toggle switch in the CLEAN position. The dump valve will open and drain the water from the evaporator and reservoir.

Step 3 Wait approximately 30 seconds (or until the evaporator is drained) and place the toggle switch in the OFF position.

Step 4 Refer to the chart and add the correct amount of sanitizer and cool water for your model ice machine.

Model	Amount of Sanitizer	Amount of Water
CNF201 CNF202	2 ounces (60 ml)	3 gallons (11 liters)

Step 5 Remove the top cover from the ice chute and pour the sanitizer/water solution into the evaporator. Add the entire amount of premixed solution (excess solution will exit through the overflow tube in the water reservoir).

Step 6 Replace the ice chute cover and allow the ice machine to stand for 30 minutes.

Step 7 Turn on the water supply to the ice machine.

Step 8 Move the toggle switch to the ICE position. After the 15 minute delay period expires the compressor will energize and produce ice with the sanitizing solution.

Step 9 The ice machine will freeze and discharge the sanitizing solution into the bin. Allow the cycle to run for 15 minutes.

NOTE: Discard all ice produced during the sanitizing process.

Step 10 Place the toggle switch in the CLEAN position. The ice machine will run a wash cycle, a series of rinse cycles and then stop. This entire cycle lasts approximately 30 minutes.

Step 11 Refer to Component Disassembly for Cleaning/Sanitizing (page 19), remove clean and sanitize all parts listed.

Component Disassembly for Cleaning/Sanitizing

The ice machine must be disassembled cleaned and sanitized every six months.

⚠ Caution

Do not mix Cleaner and Sanitizer solutions together. It is a violation of Federal law to use these solutions in a manner inconsistent with their labeling.

1. Turn off water supply to ice machine.

⚠ Warning

Wear rubber gloves and safety goggles (and/or face shield) when handling Ice Machine Cleaner or Sanitizer.

2. Place toggle switch in the CLEAN position for 30 seconds to drain water from reservoir, then move toggle switch to OFF position.
3. Run dispenser to transfer all ice from the bin to a container.

⚠ Warning

Disconnect electric power to the ice machine at the electric switch box before proceeding.

4. Disconnect electrical power to the ice machine.
5. Remove top cover.
 - A. Remove two thumbscrews.
 - B. Lift up on top cover to remove.

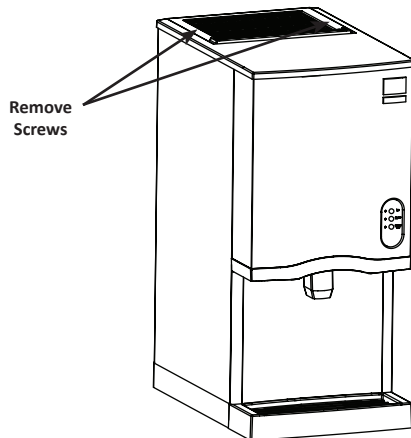

6. Remove front cover.
 - A. Lift up on front cover.
 - B. Pull forward to disengage keyhole slots.

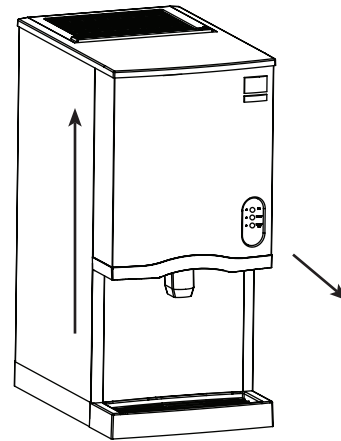

7. Remove ice chute cover.
 - A. Turn the two thumbscrews 1/4 turn.
 - B. Lift to remove cover.

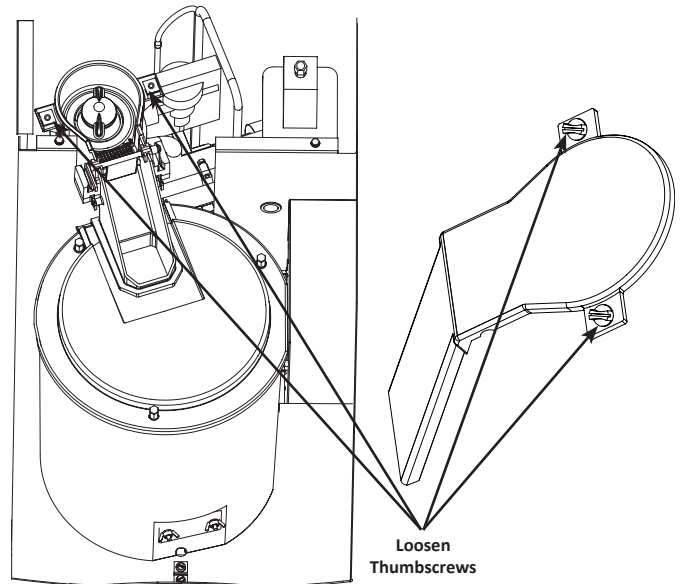

8. Lift out ice damper.

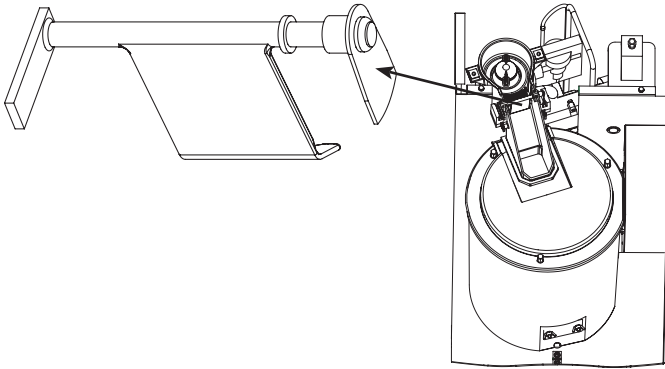

9. Lift out ice strainer ramp.

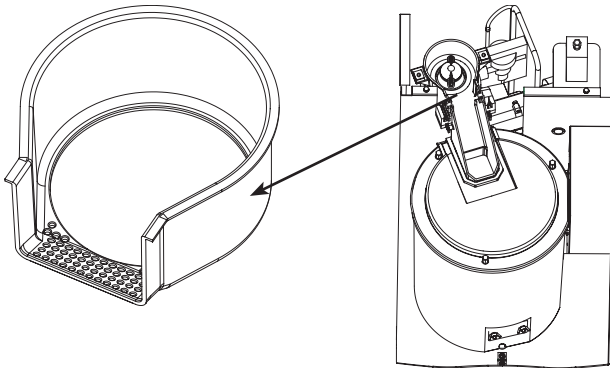

10. Turn ice wiper counterclockwise to remove.

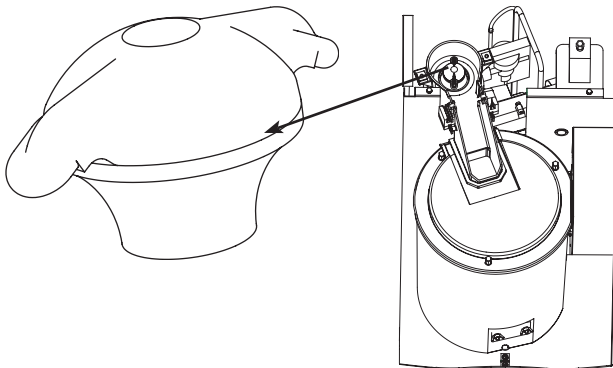

11. Loosen ice chute hose clamp.

12. Disconnect ice chute drain.

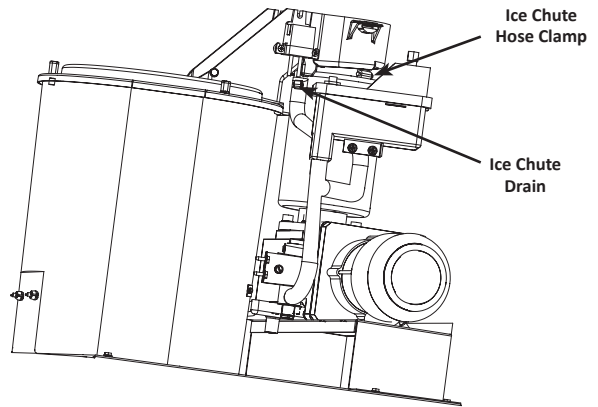

13. Lift up on ice chute to remove. The ice chute must be removed before the bin cover can be removed.

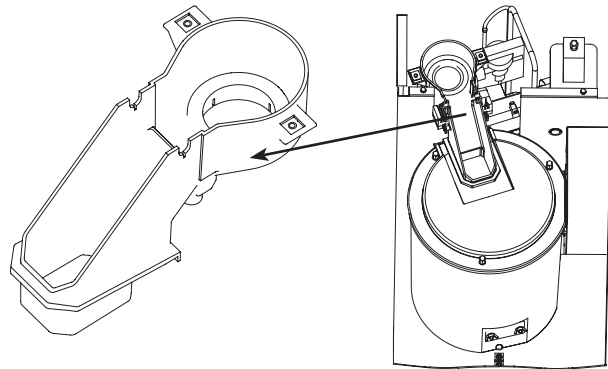

14. The ice chute can be cleaned in place. If complete removal is desired, use a Phillips screwdriver to remove the Hall Effect switch assembly from the ice chute.

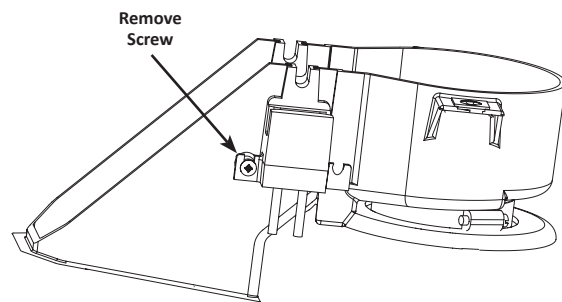

15. Remove three thumbscrews, then remove bin cover.

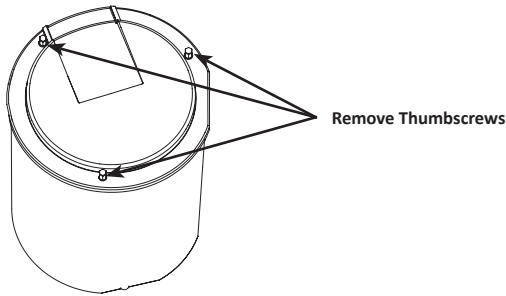

16. Remove agitator bar and ice breaker on CNF202.

NOTE: Bar must be reassembled by inserting front edge into the paddle wheel, then lowering the back edge (rounded 90 angle) to prevent water leakage into the compressor compartment.

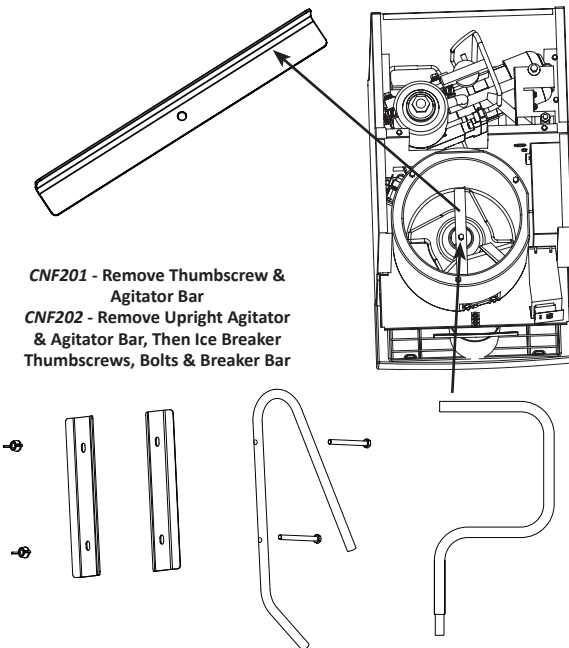

17. Remove ice deflector.

- A. Remove the two thumbscrews.
- B. Lift the ice deflector out.

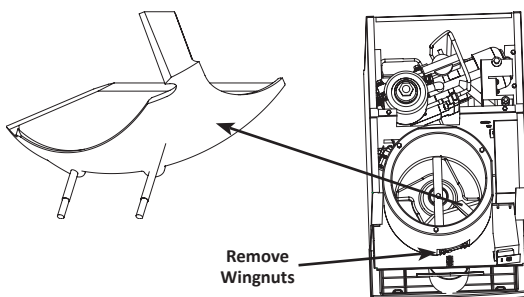

18. Remove ice dispensing wheel by lifting straight out.

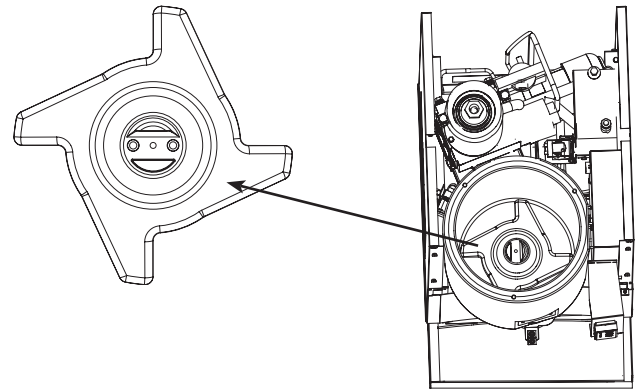

19. Remove the water reservoir cover.

- A. Push up on cover to snap off.

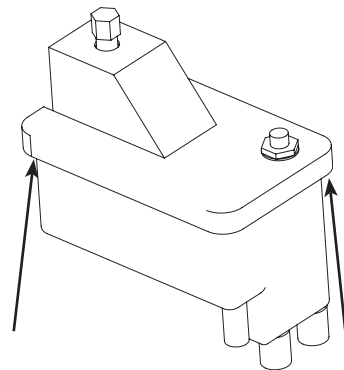

20. Mix a solution of cleaner and warm water. Depending upon the amount of mineral buildup, a larger quantity of solution may be required. Use the ratio in the table below to mix enough solution to thoroughly clean all parts.

Solution Type	Water	Mixed With
Cleaner	1 gal. (4 l)	16 oz (500 ml) cleaner

21. Use the cleaner/water mixture to clean all components. The cleaner solution will foam when it contacts lime scale and mineral deposits; once the foaming stops, use a soft-bristle nylon brush, sponge or cloth (NOT a wire brush) to carefully clean the parts. Soak parts for 5 minutes (15 - 20 minutes for heavily scaled parts). Rinse all components with clean water.

⚠ Caution

Do not pour cleaner or sanitizer solutions into the bin. The solution will leak out of the front of the bin and into the compressor compartment.



22. While components are soaking, clean all foodzone surfaces of the bin. Rinse all areas thoroughly with clean water.

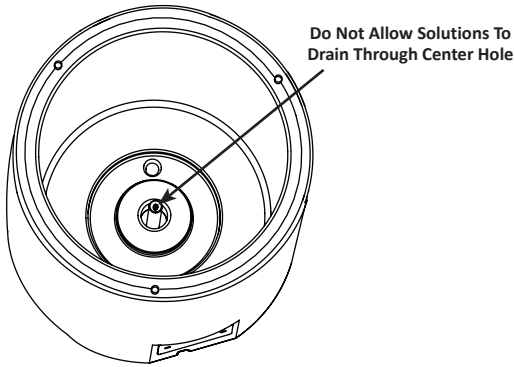

23. Mix a solution of sanitizer and warm water.

Solution Type	Water	Mixed With
Sanitizer	6 gal. (23 l)	4 oz (120 ml) sanitizer

24. Use 1/2 of the sanitizer/water solution to sanitize all removed components. Use a cloth or sponge to liberally apply the solution to all surfaces of the removed parts or soak the removed parts in the sanitizer/water solution. Do not rinse parts after sanitizing.

25. Use 1/2 of the sanitizer/water solution to sanitize the dispenser bin, water trough and delivery spout. Use a cloth or sponge to liberally apply the solution. Do not rinse the sanitized areas.

26. Reinstall the removed parts, restore water and power supply and test run the ice machine.

NOTE: Disconnecting and reconnecting the power supply activates a 15 minute time delay. This delay period can not be over ridden. The delay period will start when power is restored and the ice machine starts after the 15 minute delay period expires.

Cleaning the Condenser

Warning

Disconnect electric power to the ice machine and the remote condenser at the electric service switch before cleaning the condenser.

Air-Cooled Condenser

A dirty condenser restricts airflow, resulting in excessively high operating temperatures. This reduces ice production and shortens component life. Clean the condenser at least every six months. Follow the steps below.

Caution

The condenser fins are sharp. Use care when cleaning them.

1. The washable filter is designed to catch dust, dirt, lint and grease. This helps keep the condenser clean. Clean the filter with a mild soap and water solution.
2. Clean the outside of the condenser with a soft brush or a vacuum with a brush attachment. Clean from top to bottom, not side to side. Be careful not to bend the condenser fins.
3. Shine a flashlight through the condenser to check for dirt between the fins. If dirt remains:
 - A. Blow compressed air through the condenser fins from the inside. Be careful not to bend the fan blades.
 - B. Use a commercial condenser coil cleaner. Follow the directions and cautions supplied with the cleaner.
4. Carefully wipe off the fan blades and motor with a soft cloth. Do not bend the fan blades. If the fan blades are excessively dirty, wash with warm, soapy water and rinse thoroughly.

Notice

If you are cleaning the condenser fan blades with water, cover the fan motor to prevent water damage.



Removal from Service/Winterization

GENERAL

Special precautions must be taken if the ice machine head section is to be removed from service for an extended period of time or exposed to ambient temperatures of 32°F (0°C) or below.

Notice

If water is allowed to remain in the ice machine in freezing temperatures, severe damage to some components could result. Damage of this nature is not covered by the warranty.

Follow the procedure below.

1. Disconnect the electrical power at the circuit breaker or the electric service switch.
2. Turn off the water supply.
3. Disconnect and drain the incoming ice-making water line at the rear of the ice machine.
4. Disconnect drain tubing (from the inlet to dump valve) and drain water into container and discard.
5. Make sure water is not trapped in any of the water lines, drain lines, distribution tubes, etc.

THIS PAGE INTENTIONALLY LEFT BLANK



Section 5 Troubleshooting

Checklist

If a problem arises during operation of your ice machine, follow the checklist below before calling service. Routine adjustments and maintenance procedures are not covered by the warranty.

Problem	Possible Cause	To Correct
Ice machine does not operate Blue light on dispenser spout is off	No electrical power to the ice machine	Reset the breaker/turn on main power switch/plug cord into receptacle
	ICE/OFF/CLEAN toggle switch set improperly	Move toggle switch to the ICE position
Blue light on dispenser spout is on	Control Board fuse open	Replace the fuse
	15 minute delay has not expired	Wait 15 minutes for ice machine to start
	High Pressure Control is open	Clean filter and condenser
	Water reservoir is empty. (Water sensing switch must be closed to start the gearmotor)	Open water service valve or clean float valve screen
Gear Motor runs but compressor will not start.	Dirty air filter and/or condenser causes the high pressure cutout and compressor overload to open	Clean air filter and condenser - Disconnect power for minimum 4 hours then energize. If problem persists contact a qualified service company to determine cause.
Ice machine stops and can be restarted by moving the toggle switch to OFF and back to ICE	The SafeGuard feature is stopping the ice machine	Refer to "SafeGuard Feature" in service manual
Ice quality is poor	Poor incoming water quality	Contact a qualified service company to test the quality of the incoming water and check filter
	Water filtration is poor	Replace filter
	Incoming water temperature is above 90°F (32°C)	Correct water temperature. (Verify check/mixing valves in other equipment are working properly). Connect the ice machine to a cold water supply
	Water pressure is low	Water pressure must remain between 20 and 80 psig (138 and 552 kPa)
	Water softener is working improperly (if applicable)	Repair the water softener
Low ice capacity or Ice machine turns Off & On repeatedly	Incoming water supply is shut-off	Open the water service valve
	Water dump valve is leaking	Clean the dump valve
	Water Pressure is low. The water sensing switch turns off the ice machine repeatedly	Water pressure must remain between 20 and 80 psig (138 and 552 kPa)
	Incoming water temperature is above 90°F (32°C)	Correct water temperature. (verify check/mixing valves in other equipment is working properly)
	Frequent power interruptions or power surges/dips	Verify ice machine is on a separate circuit and power is stable
	Water float valve stuck open or leaking	Remove the float valve and clean it
	Objects stacked around ice machine, blocking airflow to condenser	Remove items blocking airflow
	High air temperature around ice machine	Air temperature must not exceed 110°F (43°C)
	Inadequate clearance around the ice machine	Provide adequate clearance
The condenser is dirty	Clean the condenser	

THIS PAGE INTENTIONALLY LEFT BLANK



**WELBILT®**
*Bringing innovation to the table***WWW.WELBILT.COM**

Welbilt provides the world's top chefs, and premier chain operators or growing independents with industry leading equipment and solutions. Our cutting-edge designs and lean manufacturing tactics are powered by deep knowledge, operator insights, and culinary expertise. All of our products are backed by KitchenCare® – our aftermarket, repair, and parts service.

- ▶ CLEVELAND
- ▶ CONVOTHERM®
- ▶ DELFIELD®
- ▶ FITKITCHEN™
- ▶ FRYMASTER®
- ▶ GARLAND
- ▶ KOLPAK®
- ▶ LINCOLN
- ▶ MANITOWOC®
- ▶ MERCO®
- ▶ MERRYCHEF®
- ▶ MULTIPLEX®