















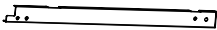

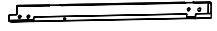





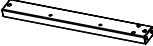

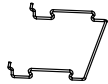



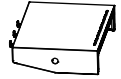

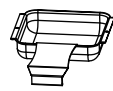

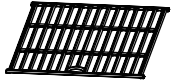

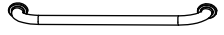
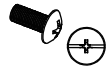
No.	#	QTY / CANT. / QTÉ	Description / Descripción / Description	Image / Imagen / Image
1	05-JSL-36	2	Leg base Base de la pata Base des pieds	
2	05-SLL-02	2	Wheel Rueda Roue	
3	AJDB044B	1	Bottom shelf Estante inferior Etagere inferieure	
4	06-XZL-1-20-DY	1	Wheel axle Eje de las ruedas Axe de roue	
5	05-LGL-05-WH	2	Rim cover Cubierta de la llanta Couverture de la jante	
6	AJQPGDZ01	1	Screw bushing Buje del perno de fijación de la bombona Douille de vis	
7	07-QPG-05-SI	1	LP cylinder screw Perno de fijación de la bombona Vis de bouteille de gaz	
8	AJBJTLF01	1	Left front leg Pata delantera izquierda Jambe avant gauche	
9	AJBJTRF01H	1	Right front leg Pata delantera derecha Jambe avant droite	
10	AJBJTLB01	1	Left back leg Pata trasera izquierda Jambe arrière gauche	
11	AJBJTRB01H	1	Right back leg Pata trasera derecha Jambe arrière droite	
12	AJQDB024B	1	Cart board Panel de carro Panneau du chariot	
13	AJQZSB014B	1	Decoration board Panel decorativo Panneau de décoration	
14	AJQHL03H4B	1	Cart front beam Barra frontal del carro Poutre avant du chariot	
15	AJHHL02H4B	1	Cart beam Barra del carro Poutre du chariot	
16	AJCHL02	2	Cart side beam Viga lateral del carro Poutre latérale du chariot	
17	06-XZL-3-24-DD1	1	Paper towel holder Portarrollos de papel Porte-serviettes en papier	

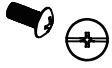
No.	#	QTY / CANT. / QTÉ	Description / Descripción / Description	Image / Imagen / Image
18	03-WZJ-A-01-DD1	1	Trash bag holder Marco para bolsas de basura Porte-sac poubelle	
19	06-XZL-4-01-DD1	1	LP cylinder barrier bar Barra de seguridad para la bombona de gas Barre de barrière de bouteille de gaz	
20		1	Main body Cuerpo principal Corps principal	
21	AJQPGB01-DS1	1	Thermal baffle Deflector térmico Panneau isolant	
22	AT31GDCTL01H	1	Side shelf (L) Bandeja lateral (I) Étagère latérale (G)	
23	AT31GDCTR01H	1	Side shelf (R) Bandeja lateral (D) Étagère latérale (D)	
24	ALJYP014B-DS2	1	Grease tray Bandeja de recogida de grasa Lêchefrite	
25	ALYB01H-LS4	1	Grease cup Depósito de recogida de grasa Bac à graisse	
26	ALFHB01-SS4	4	Flame tamer Regulador de llama Atténuateur de flam	
27	03-ZTW-A-01-TC4	2	Cooking grate Rejilla para asar Grille de cuisson	
28	03-BWW-A-01 -4B-DD1	1	Warming rack Rejilla para calentar Grille de réchauffement	
29	04-GBS-2-54 -500-PG	1	Handle manija Poignée	

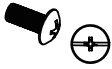
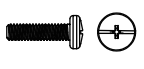
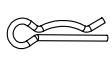
No.	#	Image / Imagen / Image	No.	#	Image / Imagen / Image
A	M6x12	 ×38	F	Hose holder Anilla de fijación Support de tuyau	 ×1
B	M5x10	 ×23	G	Washer Arandela Rondelle	 ×6
C	M4x12	 ×1	H	M6x20	 ×2
D	Split pin Pasador partido Goupille fendue	 ×1	I	M6	 ×2
E	Pad Arandela Tampon	 ×2	J	Washer Arandela Rondelle	 ×2

**TOOLS REQUIRED / HERRAMIENTAS REQUERIDAS / OUTILS REQUIS**

Phillips screwdriver Destornillador phillips Tournevis phillips	Wrench Llave Clé	
---	------------------------	--

Before beginning assembly, make sure all parts are present. If any parts are missing or damaged, do not attempt to assemble the products. Contact customer service for replacement parts via telephone or email.

- Tools needed (not included): Phillips screwdriver and wrench
- Approximate assembly time: 45-60 minutes
- Note: 1. The right and left sides of the grill are designed as if you are facing the front of the grill.  
2. Model shown for illustration purpose only, specific please in kind prevail.

Antes de comenzar el montaje, asegúrese de que todas las piezas estén presentes. Si falta alguna pieza o está dañada, no intente ensamblar los productos. Póngase en contacto con el servicio de atención al cliente para obtener piezas de repuesto por teléfono o correo electrónico.

- Herramienta necesaria (no incluido): Destornillador phillips y llave
- Tiempo aproximado de ensamblaje: 45-60 minutos
- Nota: 1. Los lados derecho e izquierdo de la parrilla están diseñados como si estuvieras frente a la parte delantera de la parrilla.  
2. El modelo que se muestra es sólo para fines ilustrativos, prevalecen los específicos en especie.

Avant de commencer l'assemblage, assurez-vous que toutes les pièces sont présentes. Si des pièces sont manquantes ou endommagées, n'essayez pas d'assembler les produits. Contactez le service de clientèle pour les pièces de rechange par téléphone ou par e-mail.

- Outils nécessaires (non inclus): Tournevis phillips et clé
- Temps nécessaire pour l'assemblage: 45-60 minutes
- Remarque: 1. les côtés droit et gauche du gril sont conçus comme si vous faisiez face à l'avant du gril.  
2. le modèle est présenté à des fins d'illustration uniquement, spécifiques en nature prévalent.

1 A  ×2

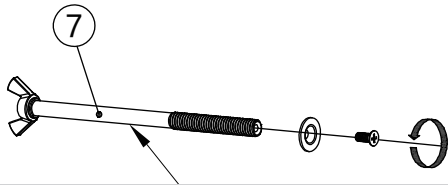
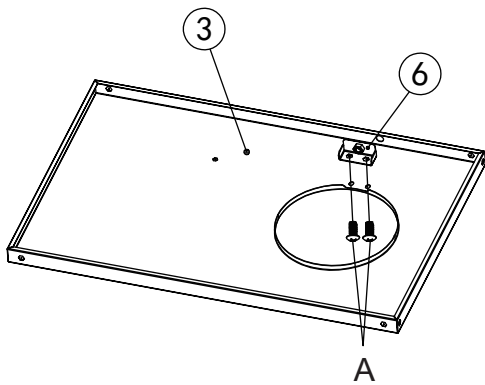

- Use the pre-installed screws from the LP cylinder screw.
- Utilice los tornillos preinstalados del tornillo del cilindro LP.
- Utilisez les vis pré-installées de la bonbonne de gaz LP.

2

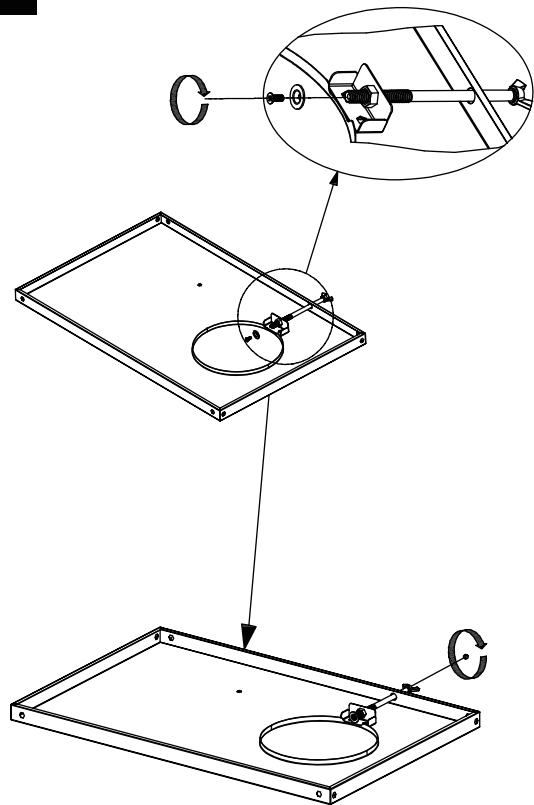

3 A  ×4

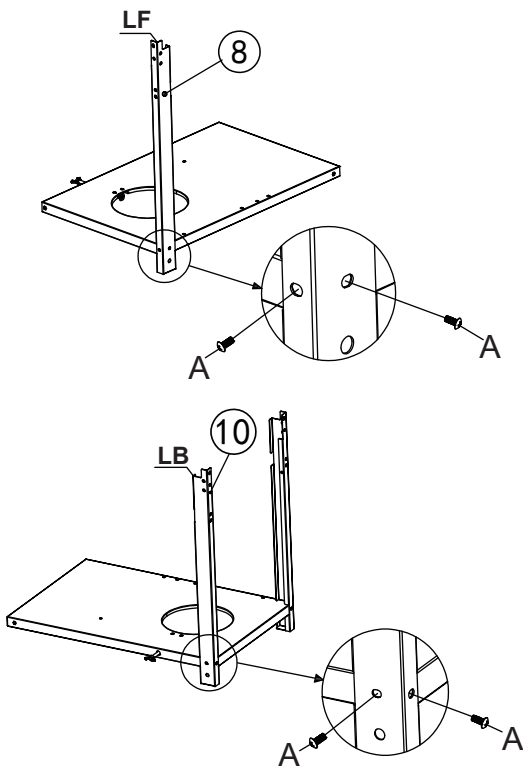

4

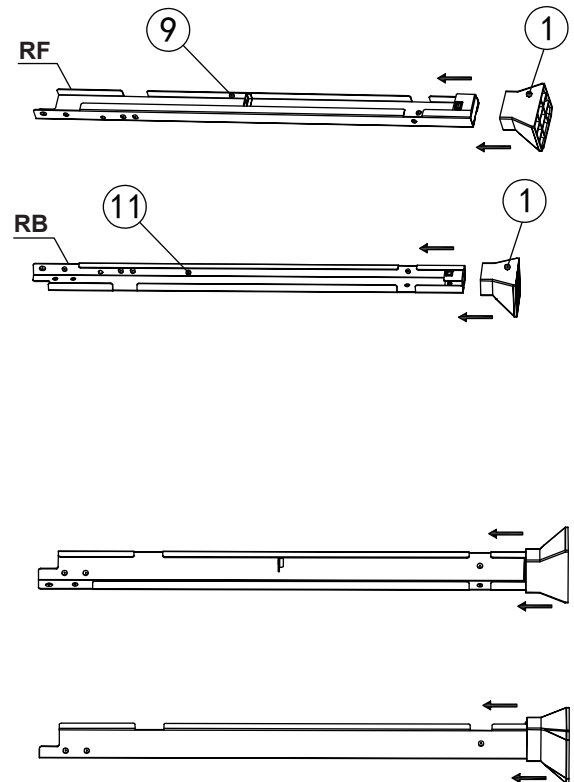

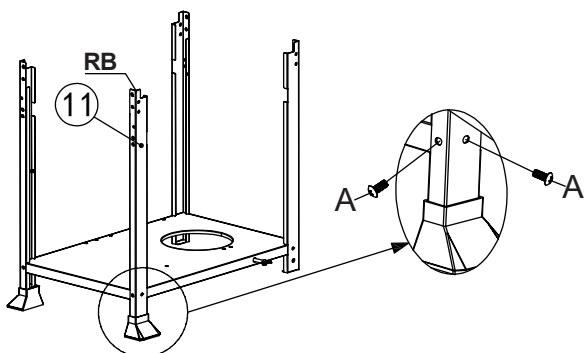
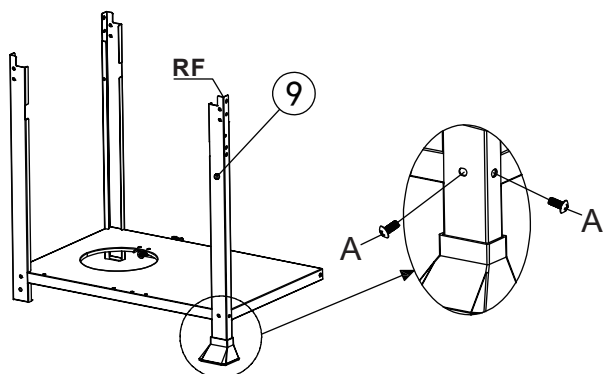

**5** A  ×4

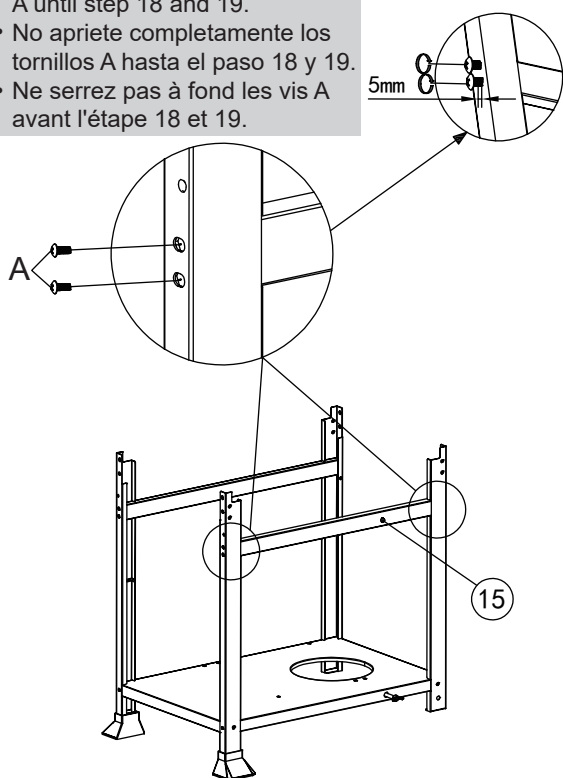

**7** A  ×4

- Do not fully tighten the screws A until step 18 and 19.
- No apriete completamente los tornillos A hasta el paso 18 y 19.
- Ne serrez pas à fond les vis A avant l'étape 18 et 19.



**6** A  ×4

- Do not fully tighten the screws A until step 18 and 19.
- No apriete completamente los tornillos A hasta el paso 18 y 19.
- Ne serrez pas à fond les vis A avant l'étape 18 et 19.

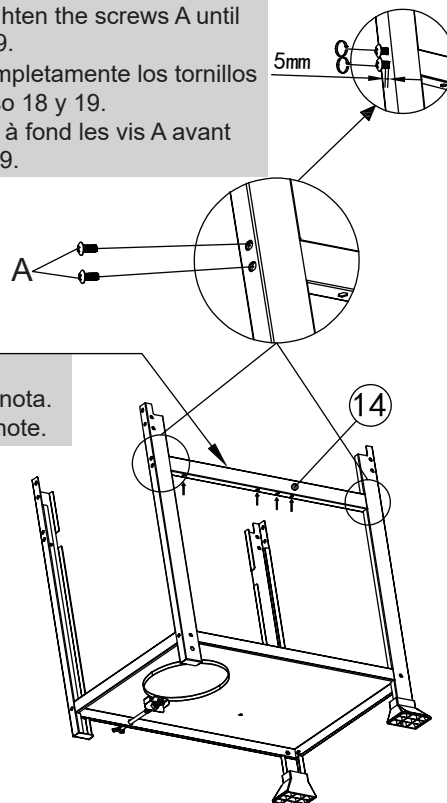

- Note direction
- Dirección de la nota.
- Direction de la note.

**8** B  ×4

- With holes in these two positions is the front side.
- El lado frontal es el que tiene agujeros en estas dos posiciones.
- Lorsque les trous sont dans ces deux positions, c'est la face avant.

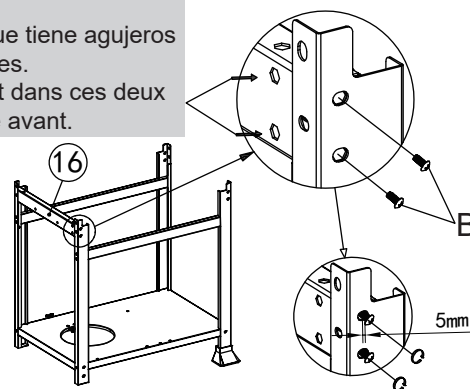

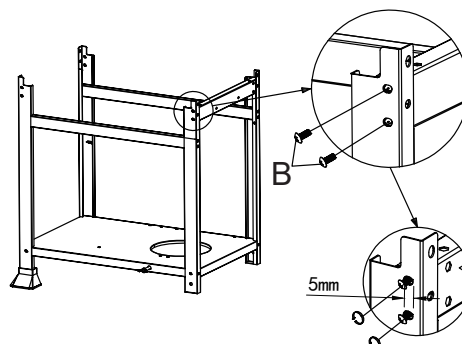

- Do not fully tighten the screws B until step 18.
- No apriete completamente los tornillos B hasta el paso 18.
- Ne serrez pas à fond les vis B avant l'étape 18.

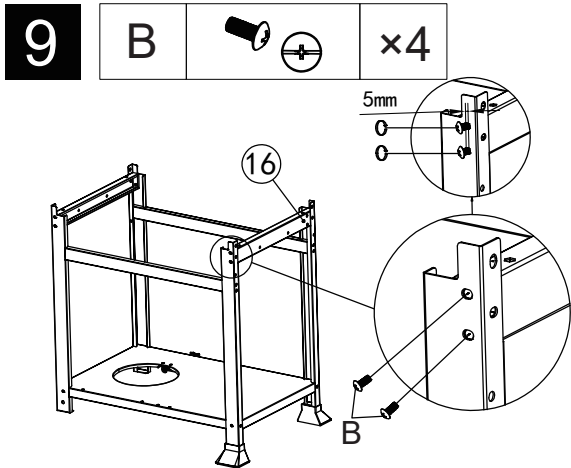

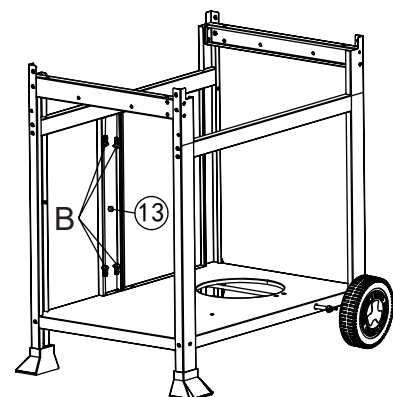
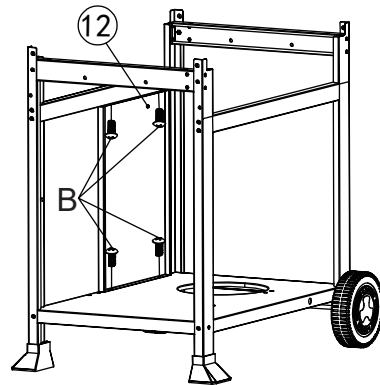
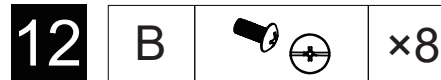
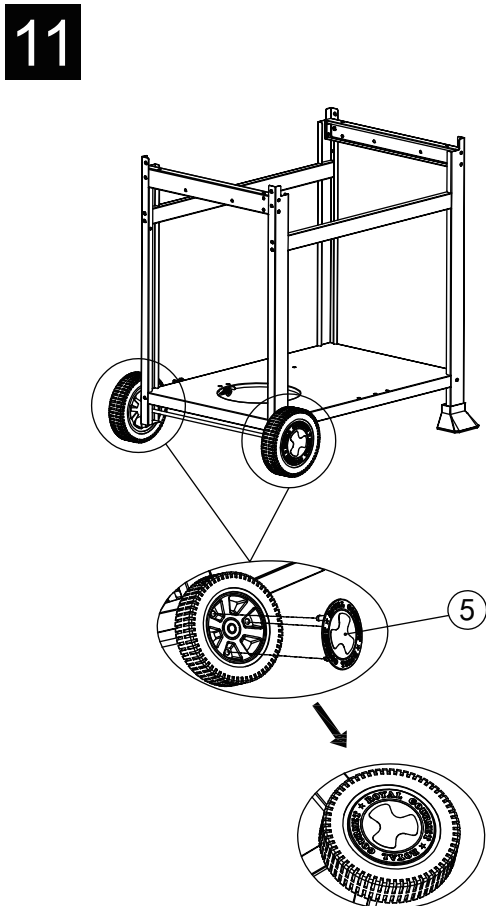
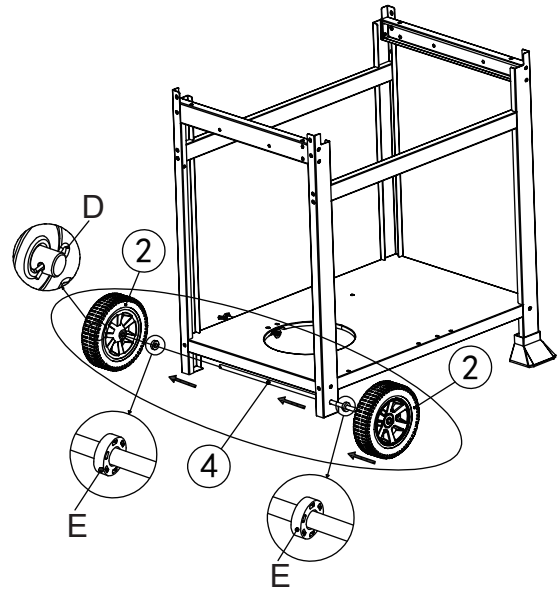
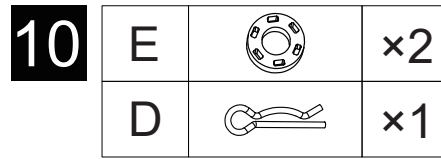
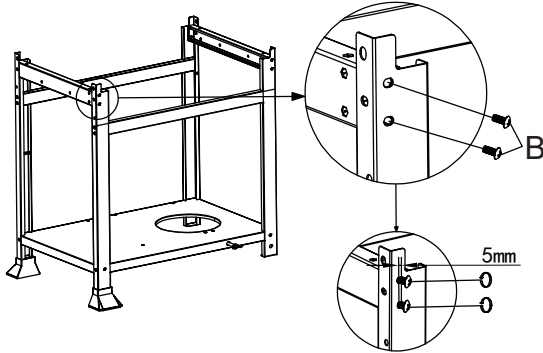

- Do not fully tighten the screws B until step 19.
- No apriete completamente los tornillos B hasta el paso 19.
- Ne serrez pas à fond les vis B avant l'étape 19.



**13** A  x2

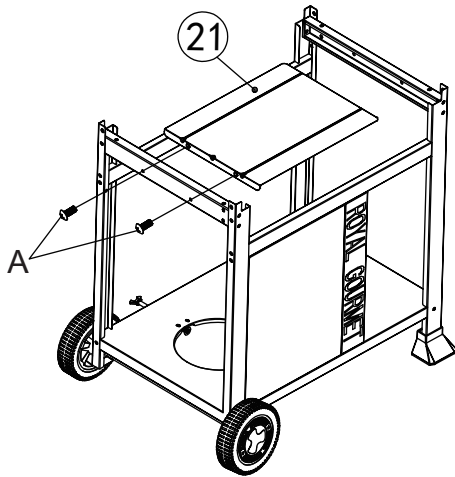

**14** B  x2

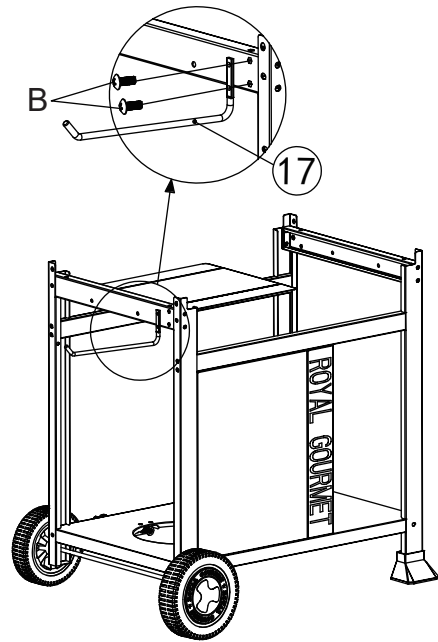

**15** B  x1

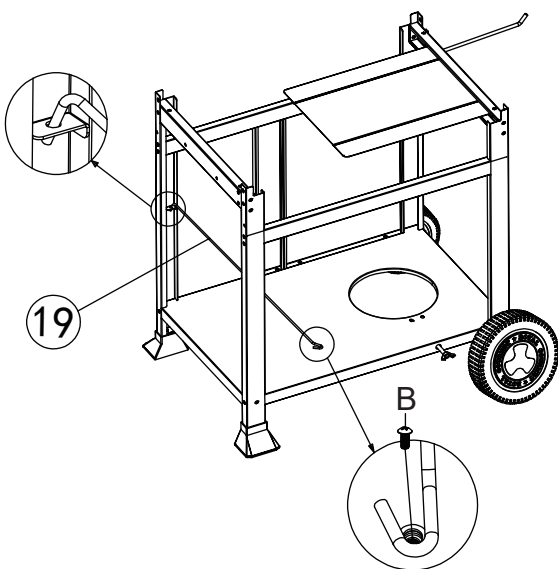

**16**

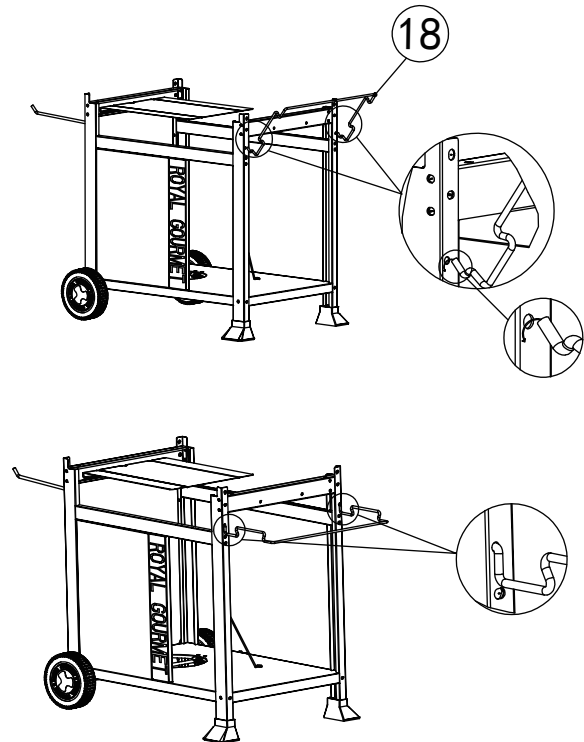

17

- Ignition module
- Módulo de ignición
- Module d'allumage

- Regulator
- Regulador
- Régulateur

- Release the ignitor and regulator in advance.
- Libere el encendedor y regulador por adelantado.
- Deverrouillez l'allumeur et le régulateur à l'avance.

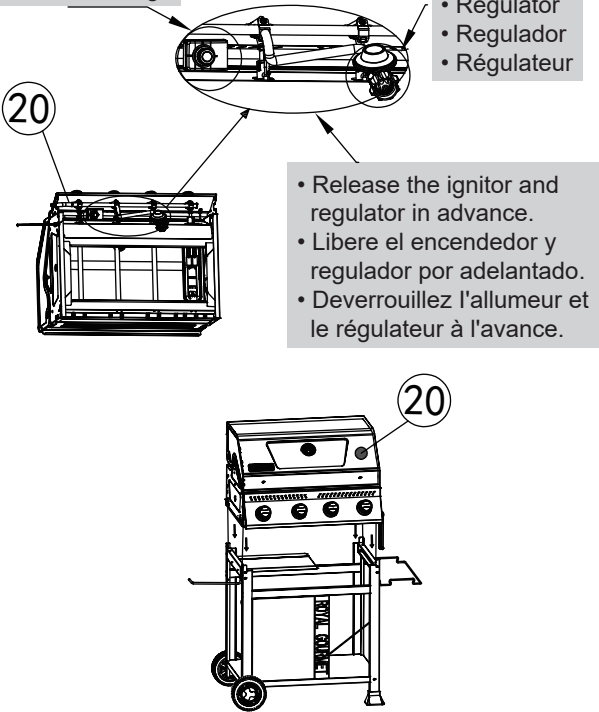

18

A  ×4

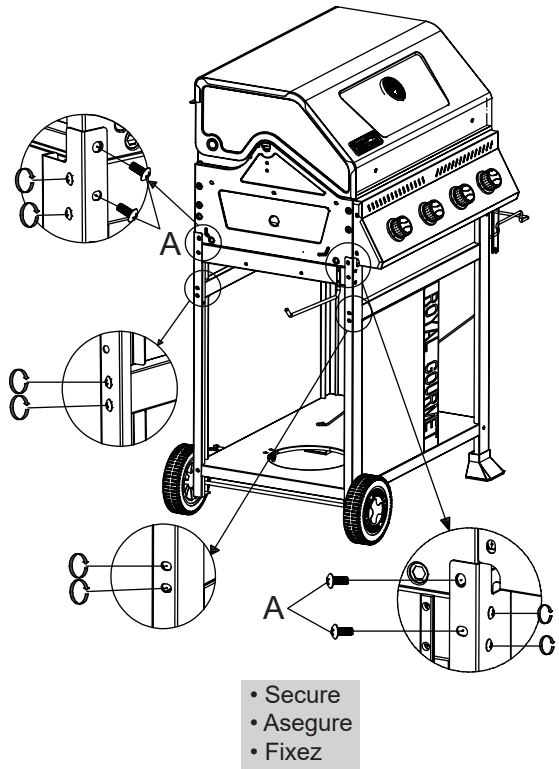

- Secure
- Asegure
- Fixez

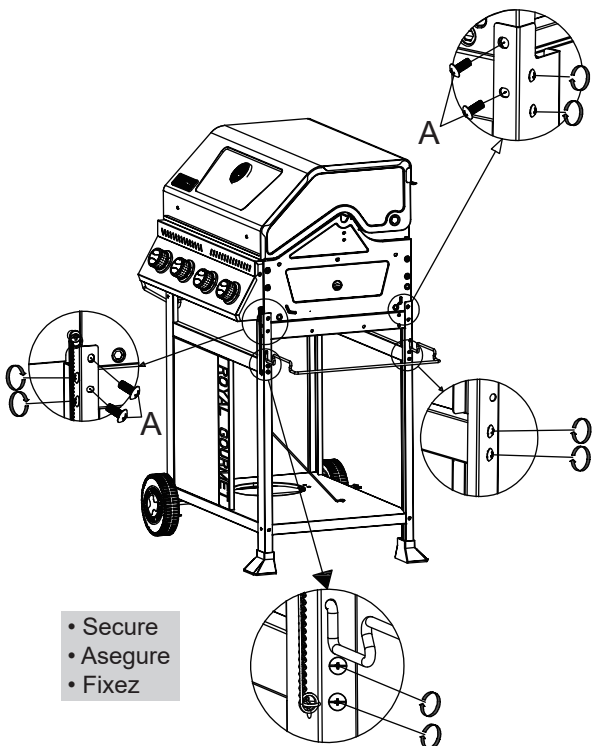

19

A  ×4





- Secure
- Asegure
- Fixez

20

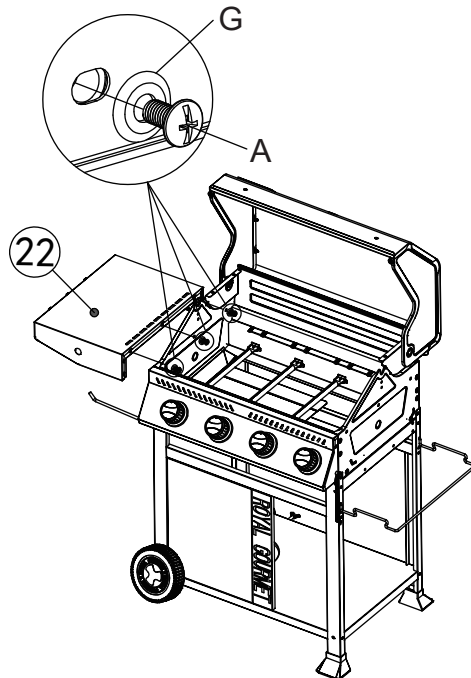
G  ×3  
A  ×3

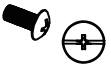

21	B		×2
	A		×2

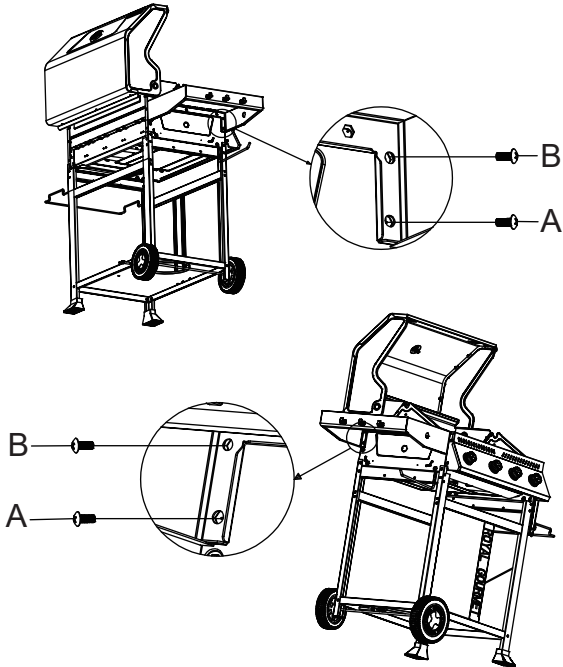

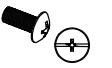
22	G		×3
	A		×3

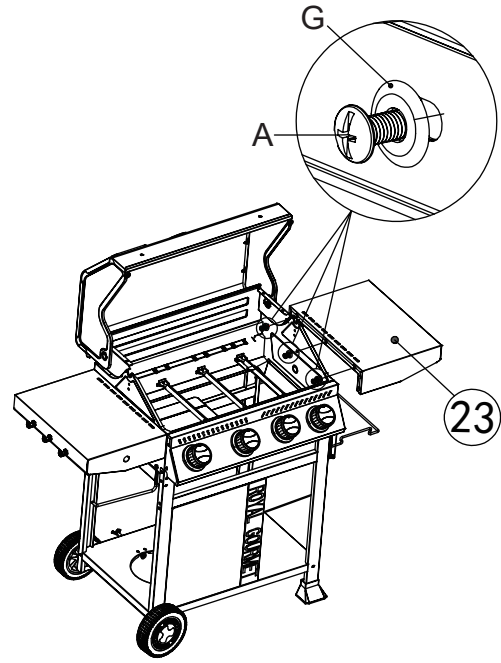

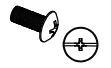
23	B		×2
	A		×2

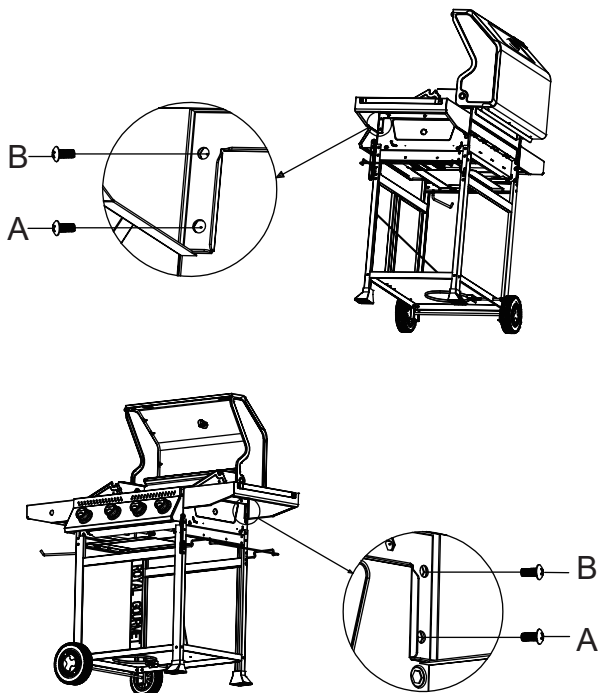

24

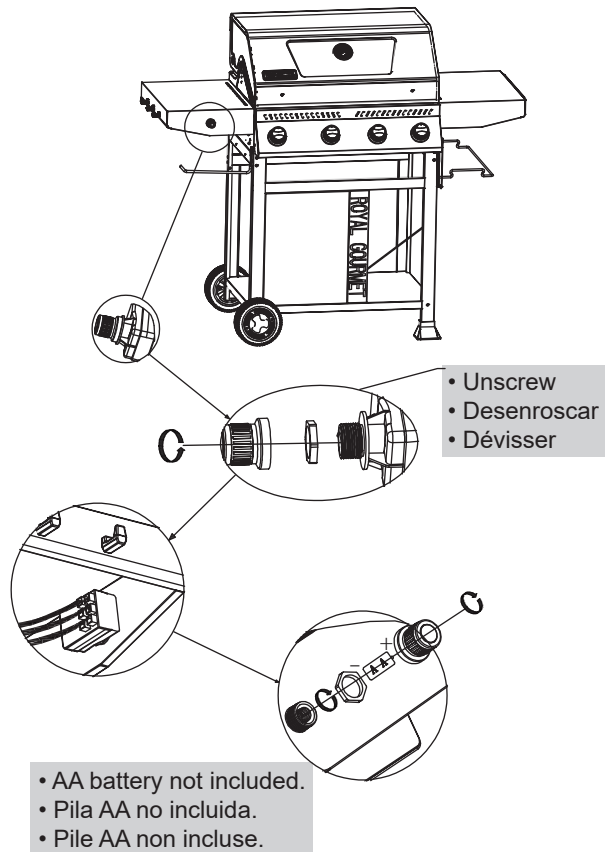

25

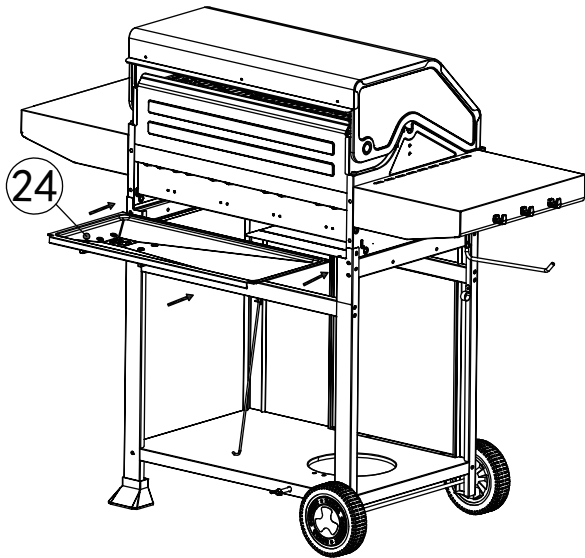

26

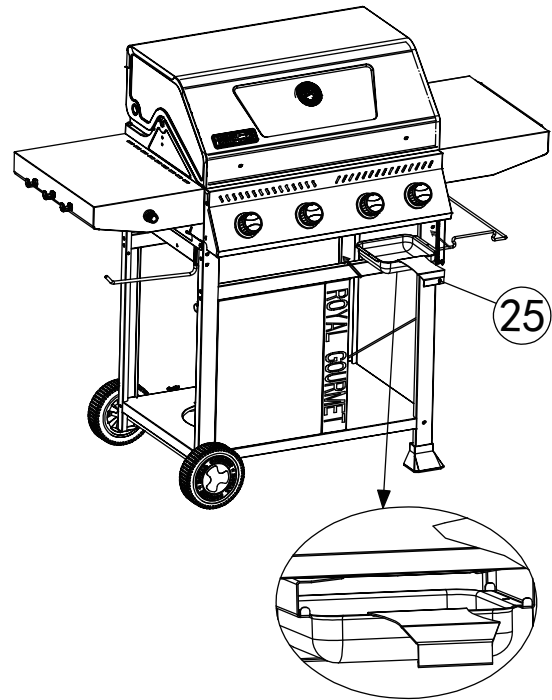

27

J		x2
I		x2
H		x2

28

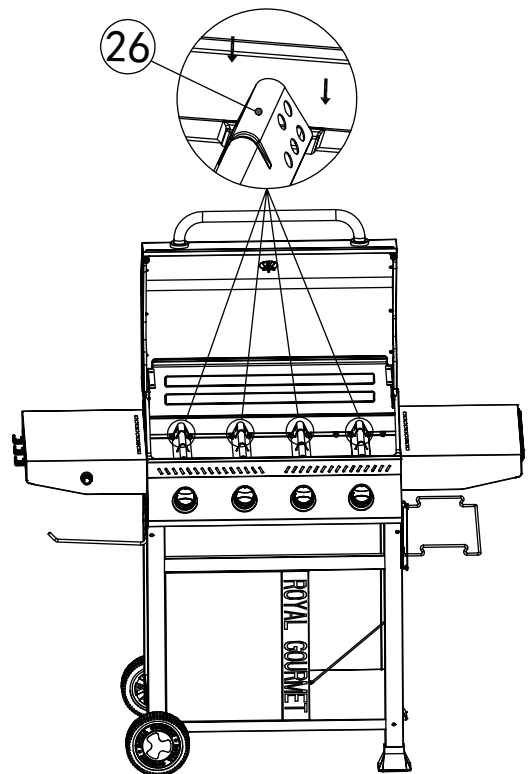
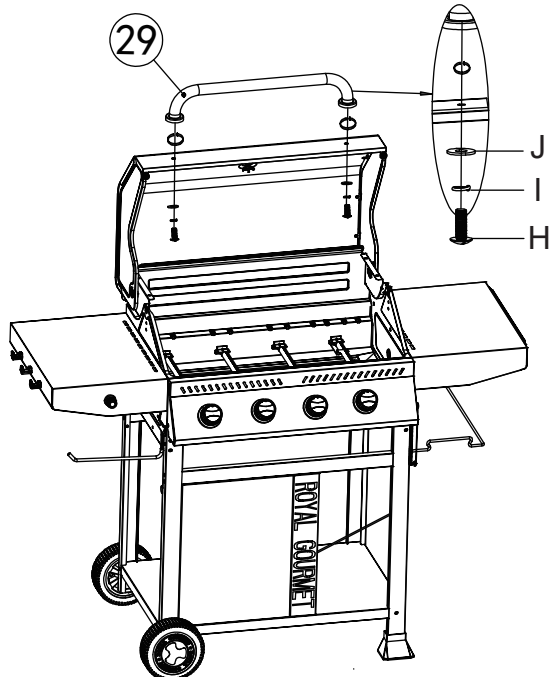

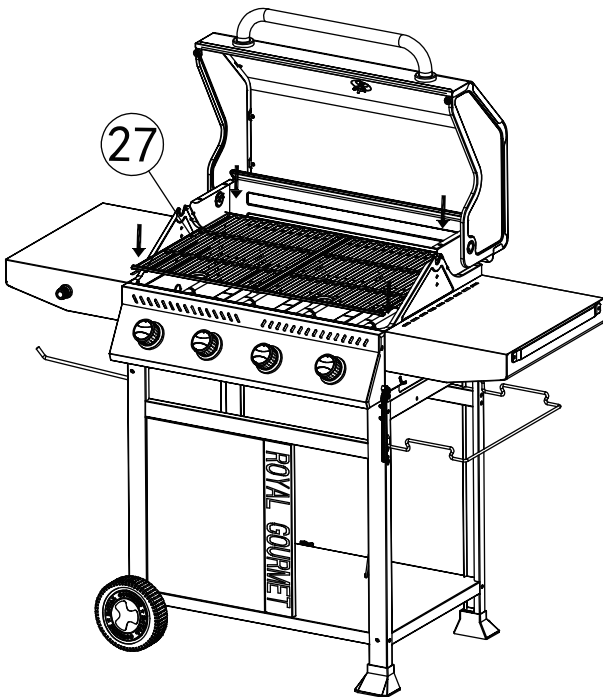

29

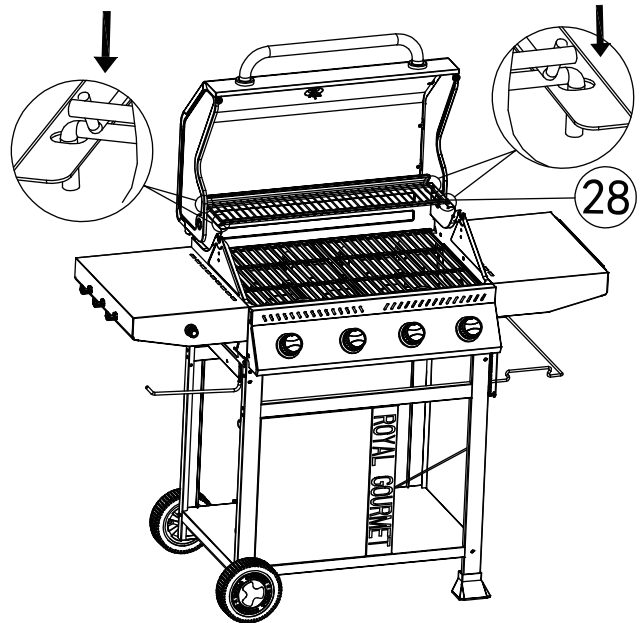

30



31

C		x1
F		x1

- Not included
- No incluida
- Non incluse

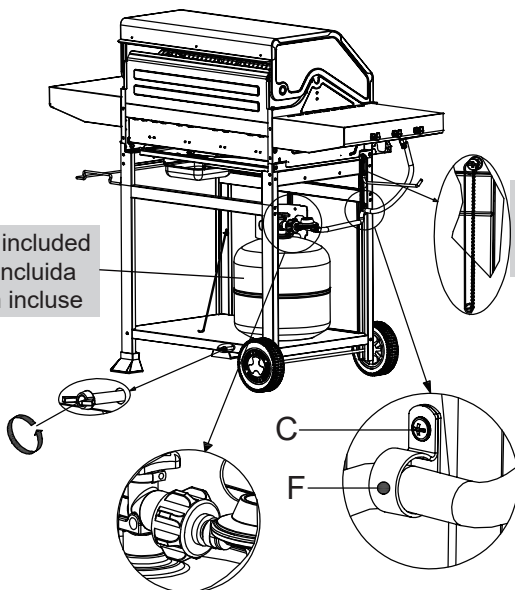

- Please hang the match-stick holder here after using.
- Cuelgue el soporte para cerillas aquí después de usarlo.
- Veuillez accrocher le porte-allumettes ici après utilisation.

**Thank You  
For Choosing Us.**

**Any Problem!  
We Can Help!**

**Customer  
Service**

**1-800-618-6798**

**Monday to Friday ( 8:30 am - 5:00 pm EST )**

**[service@royalgourmetusa.com](mailto:service@royalgourmetusa.com)**